

# Automation Engine 23

Complete Manual

11 - 2023

# Contents

<b>1. What's New?</b> .....	<b>31</b>
1.1. What's New in this Version?.....	31
<b>2. Introducing Automation Engine</b> .....	<b>32</b>
2.1. What is Automation Engine?.....	32
2.1.1. Client-Server Architecture.....	32
2.1.2. Data Management and Central Resources.....	33
2.1.3. Multi-Site Environments.....	33
2.1.4. On-Premises or SaaS.....	34
2.1.5. Scalability and Security.....	34
2.1.6. The Automation Engine Viewer.....	35
2.1.7. Integration with Other Applications.....	35
2.1.8. Scripting.....	36
2.1.9. More Help?.....	36
2.2. File Types and How they are Recognized.....	37
2.3. Important Concepts and Work Modes.....	40
2.3.1. Containers (introduction).....	40
2.3.2. Jobs (introduction).....	41
2.3.3. Products (introduction).....	43
2.3.4. Page Workflow Views and Tools (introduction).....	43
<b>3. PDF Formats and Metadata</b> .....	<b>44</b>
3.1. Normalized PDF and XMP in Automation Engine.....	44
3.1.1. Introduction.....	44
3.1.2. What Makes a Normalized PDF Special?.....	44
3.1.3. Which Tasks Require PDF Normalization?.....	45
3.1.4. How do PDF native tasks Work with Normalized PDF Files?.....	47
3.1.5. How do Normalized PDF Tasks handle native PDF Files?.....	47
3.1.6. PDF Normalization and Step & Repeat.....	49
3.1.7. Normalized PDF XMP Metadata (the File's Info Dialog).....	51
3.2. PDF+ in Automation Engine.....	52
3.2.1. PDF+, Successor of Normalized PDF.....	52
3.2.2. Metadata in PDF+ (vs. XMP in Normalized PDF).....	55
3.2.3. PDF+ File's Info Dialog.....	57
3.2.4. Which AE task Uses which Technology?.....	66
3.2.5. Workflow and Current Limitations.....	74
<b>4. Getting Started</b> .....	<b>76</b>
4.1. Installing Server and Clients.....	76
4.2. Changing the Language used in the Pilot, Shuttle or browser client.....	76



4.3. Signing In to the Pilot or Shuttle.....	76
4.4. The Pilot's Main Window.....	79
4.5. Concepts of Tasks, Tickets and Workflows.....	82
4.5.1. Tasks.....	82
4.5.2. Workflows.....	82
4.5.3. Tickets.....	83
4.6. First Steps in Launching Tasks.....	87
4.6.1. Launching a Task on a File.....	87
4.6.2. Checking the Status of a Task.....	88
4.6.3. Relaunching a Task.....	89
4.6.4. Launching Workflows.....	89
4.6.5. Creating Task Tickets.....	89
4.7. Performing Basic Configuration.....	91
4.7.1. Creating Favorite Tickets.....	91
4.7.2. Creating Users (Introduction).....	96
4.7.3. Configuring RIPs or Proofer.....	96
4.7.4. Pilot Preferences.....	96
4.7.5. Task Notifications.....	98
4.8. Using Public Parameters in Automation Engine.....	99
4.8.1. Making a Parameter Public.....	99
4.8.2. Managing Public Parameters in a task Ticket.....	101
4.9. Uploading Files to Automation Engine.....	104
4.9.1. Uploading Files using the Pilot.....	105
4.9.2. Uploading Files from an FTP Server.....	105
4.9.3. Using Access Points to Upload Files.....	107
4.9.4. Using Shuttle to Upload and Process Files.....	107
4.10. Launching Tasks from Editors.....	107
4.10.1. Setup Requirements.....	107
4.10.2. Launching Tasks from ArtPro+.....	107
4.10.3. Launching Tasks from Adobe Illustrator (the Shuttle Plug-in).....	107
4.10.4. Launching Tasks from ArtPro.....	108
4.10.5. Launching Tasks from PackEdge or Plato.....	110
4.10.6. Launching Tasks from FastImpose.....	111
<b>5. Pilot Views and Tools.....</b>	<b>113</b>
5.1. Concepts and Overview.....	113
5.2. General Views.....	115
5.2.1. The Files View.....	115
5.2.2. The Shared Files View.....	118
5.2.3. The To Do List View.....	118
5.2.4. The Products View.....	122
5.2.5. The WebCenter View.....	123
5.2.6. The Tasks View.....	125
5.2.7. The Milestones View.....	129

5.2.8. The SmartNames View.....	129
5.2.9. The Tickets View.....	129
5.2.10. The Jobs View.....	137
5.3. Commercial Print Views.....	137
5.4. Sign & Display Views.....	138
5.4.1. The Gang Run Printing View.....	138
5.4.2. The Orders View.....	138
5.5. Flexo Views.....	138
5.6. Cutting Tables Views.....	138
5.7. Smart Views.....	138
5.7.1. Using Filters and Creating Smart Views.....	140
5.8. Setup Views.....	141
5.8.1. Devices.....	141
5.8.2. FlexRips (soon outdated).....	143
5.8.3. Queue Monitor.....	144
5.8.4. Containers.....	146
5.8.5. Access Points.....	151
5.8.6. Customers.....	151
5.8.7. Order Materials.....	152
5.9. Accounts Views.....	152
5.9.1. Authentication and Authorization within AE.....	152
5.9.2. Users View.....	153
5.9.3. Groups View.....	159
5.9.4. Roles View.....	161
5.10. Tools Menu.....	162
5.10.1. To Do List.....	163
5.10.2. CTP Queues.....	163
5.10.3. Table Queues.....	163
5.10.4. SmartNames.....	164
5.10.5. Task History.....	164
5.10.6. Devices.....	169
5.10.7. FlexRips.....	169
5.10.8. Queue Monitor.....	169
5.10.9. Containers.....	169
5.10.10. Access Points.....	169
5.10.11. Customers.....	169
5.10.12. Order Materials.....	169
5.10.13. Merger Monitor.....	170
5.10.14. Configure.....	171
5.10.15. Connection Doctor.....	248
<b>6. Tasks and Workflow Controls.....</b>	<b>249</b>
6.1. Add Dynamic Marks.....	249
6.2. Add Ink Eaters (Classic).....	251

6.3. Add Marks to Imposition.....	255
6.4. Add Margins to LEN File.....	255
6.5. Add Parameters for Nesting (Classic).....	255
6.6. Add SmartMarks (Classic).....	255
6.7. Add to Pages View (Classic).....	256
6.8. Add To Products.....	256
6.9. Adjust PDF Screening (Classic).....	256
6.10. Adjust PDF Screening.....	258
6.11. Apply ArtPro Action List (Classic).....	259
6.12. Apply PDF Action List.....	259
6.13. Apply Creep.....	261
6.14. Apply PantoneLIVE Condition (Classic).....	261
6.15. Apply Plate ID to LENX file.....	262
6.16. Archive Job.....	262
6.17. Assign PDF Pages to RunList.....	262
6.18. Change Imposition Layout.....	262
6.19. Change Location of Inactive Jobs.....	263
6.20. Change Location of Jobs.....	263
6.21. Change Location of Products on Esko Cloud.....	263
6.22. Change Location of Products.....	263
6.23. Check Dynamic VDP Database.....	263
6.24. Check Job Parameters (Classic).....	264
6.25. Check Job and Product Parameters.....	264
6.26. Check Print Rules (PRC) (Classic).....	264
6.27. Check Product Parameters (Classic).....	265
6.28. Check Technical Inks (Classic).....	265
6.29. Compare PDF (Classic).....	265
6.30. Contourize & Clean (Classic).....	265
6.31. Convert CMYK Colors (Classic).....	265
6.32. Convert Colors for Digital Printing (Classic).....	265
6.33. Convert Colors with Equinox.....	266
6.34. Convert Colors with Equinox (Classic).....	268
6.35. Convert IMP File to Normalized PDF File (Classic).....	270
6.36. Convert JSON to XML.....	271
6.37. Convert Selection.....	271
6.38. Convert to ARD/MFG.....	271
6.39. Convert XML to JSON.....	271
6.40. Copy Inactive Job to Jobs.....	271
6.41. Copy or Move File.....	272
6.42. Create ArtiosCAD Layouts.....	272
6.43. Create ArtiosCAD Report from XML.....	273
6.44. Create Design (DesignWizard) (Classic).....	273
6.44.1. Using SmartNames in a DesignWizard template.....	274

6.45. Create Flexo Plate Cutting Paths.....	275
6.46. Create IMP File (Classic).....	275
6.47. Create Imposition from JDF Layout.....	275
6.48. Create Imposition from RunList.....	276
6.49. Create Job task.....	276
6.50. Create Merged Plate.....	276
6.51. Create Master DCS File (Classic).....	276
6.52. Create Nested Layouts (Classic).....	276
6.53. Create or Modify WebCenter Project.....	276
6.54. Create Packshot from XML.....	276
6.55. Create PAF / JPG / XML (LinkEdge) (Classic).....	277
6.55.1. Pack/UnPack.....	277
6.55.2. XML.....	278
6.55.3. JPEG.....	279
6.56. Create PDF File from JDF RunList (Classic).....	280
6.57. Create PDF File from RunList.....	280
6.58. Create PDF Report.....	280
6.59. Create Report (ReportMaker) (Classic).....	282
6.59.1. Creating a ReportMaker Template.....	284
6.59.2. Adding Previews of Details in a Report PDF.....	287
6.59.3. Adding a 3D Object to a Report PDF.....	288
6.60. Create RunList.....	289
6.61. Create RunList from PDF.....	289
6.62. Create Sheet Layout (Classic).....	289
6.62.1. Ticket settings.....	290
6.62.2. Positioning a One Up graphic onto a Station.....	294
6.62.3. Distributing the One Up graphics onto the Stations.....	295
6.62.4. Bleed and overlap.....	296
6.62.5. Bleed Overlap Priority decided by ArtiosCAD Artwork Panels.....	297
6.62.6. Using XML as input file.....	298
6.63. Create Sheet Report from IMP File (Classic).....	301
6.64. Create Tiles (Classic).....	301
6.65. Create Wrapper File (Classic).....	301
6.65.1. Page Size tab.....	301
6.65.2. Inks tab.....	302
6.65.3. Separations tab.....	303
6.66. Create XML File.....	304
6.67. Crop LEN File.....	304
6.68. Data Collector.....	304
6.69. Data Splitter.....	304
6.70. Delete File.....	305
6.71. Delete Inactive Job.....	305
6.72. Delete Product on Esko Cloud.....	305

6.73. Download Files from Shared Job.....	305
6.74. Download Product from Esko Cloud.....	305
6.75. Download WebCenter Document.....	306
6.76. Enrich Black (Classic).....	306
6.76.1. General Tab.....	306
6.76.2. Scan Tab.....	307
6.77. Expand Dynamic VDP Data.....	309
6.78. Export ArtiosCAD Design Info.....	312
6.79. Export ArtiosCAD Print Item as ARD File.....	312
6.80. Export ArtPro to Normalized PDF File (Classic).....	313
6.81. Export Gang Run Layouts (Classic).....	314
6.82. Export IMP File to GRI File (Classic).....	314
6.83. Export IMP File to JDF Layout (Classic).....	314
6.84. Export IMP File to JDF Post-Press (Classic).....	314
6.85. Export IMP File to PDF File (Classic).....	314
6.86. Export IMP File to PDF File Chain (Classic).....	314
6.87. Export IMP File to PostScript File (Classic).....	315
6.88. Export Imposition to JDF Layout (Classic).....	315
6.89. Export Imposition to PDF File (Classic).....	315
6.90. Export PDF Info.....	315
6.90.1. XML specification of Metadata+.....	317
6.91. Export Picture List.....	323
6.92. Export Step & Repeat to JDF Layout (Classic).....	324
6.93. Export Step & Repeat to JDF Layout.....	324
6.94. Export to 3D (Classic).....	325
6.94.1. Export to 3D Settings.....	326
6.95. Export to 3D.....	328
6.96. Export to ArtPro File (Classic).....	332
6.97. Export to EPS/DCS File (Classic).....	332
6.97.1. Output.....	332
6.98. Export to Gravure using HELL Job Ticket.....	334
6.99. Export to Normalized PDF File (Classic).....	334
6.100. Export to Normalized PDF File (Embed All) (Classic).....	335
6.101. Export to PDF File (Classic).....	336
6.101.1. Output.....	337
6.101.2. Device.....	340
6.101.3. Color Management.....	340
6.101.4. Compression.....	342
6.101.5. Advanced.....	343
6.102. Export to PostScript File (Classic).....	344
6.102.1. Output.....	344
6.102.2. Device.....	345
6.102.3. Color Management.....	346

6.102.4. Inks / Separations.....	347
6.102.5. Rasterize.....	348
6.102.6. Compression.....	349
6.102.7. Advanced.....	350
6.103. Export to Unscreened Separations.....	351
6.104. Extract Inks (Classic).....	353
6.105. Fill Printing Lanes.....	354
6.106. Fork.....	354
6.107. Image to Screened Separations.....	354
6.108. Image to Unscreened Separations.....	354
6.109. Import Die.....	354
6.110. Import Image (Classic).....	357
6.111. Import JDF Layout (Classic).....	359
6.111.1. Sheets.....	359
6.111.2. Page Boxes.....	360
6.112. Import JDF Step & Repeat (Classic).....	360
6.112.1. Tab 'General'.....	361
6.112.2. Tab 'CAD Options'.....	361
6.112.3. Tab 'Sheet'.....	362
6.112.4. Tab 'Plate'.....	362
6.113. Import JDF Stripping (Classic).....	362
6.114. Import Picture List.....	363
6.115. Import Substrate Sizes from XML.....	364
6.115.1. Import Substrate Sizes from XML.....	364
6.116. Import Order Material from XML.....	364
6.117. Inspect Artwork.....	366
6.118. Inspect Barcodes.....	366
6.119. Inspect Braille.....	366
6.120. Inspect Spelling.....	366
6.121. Inspect Text.....	366
6.122. Integrate via External Hot Folder.....	366
6.123. Interact using JDF.....	367
6.124. Interact using JMF.....	368
6.125. Integrate with WebCenter.....	368
6.126. Interact with Database.....	368
6.127. Interact with SAP.....	368
6.128. Interact with Web Service.....	368
6.129. Join.....	368
6.130. Join XML Files.....	368
6.131. Link Product To Job.....	368
6.132. Load Structural File (Classic).....	369
6.133. Manage Color (Classic).....	370
6.133.1. Converting to another CMYK Profile.....	370

6.133.2. Reseparating your CMYK File.....	377
6.133.3. Converting and Reseparating your File.....	380
6.134. Manage Milestone.....	380
6.135. Manage Product Status.....	380
6.136. Map Data.....	381
6.137. Mark as Proof.....	381
6.138. Mark File.....	381
6.139. Merge PDF Files (Classic).....	381
6.140. Merge PDF files.....	382
6.141. Modify Workflow Parameter Values.....	383
6.142. Move Job to Inactive Jobs.....	383
6.143. Move Inactive Job to Jobs.....	383
6.144. Normalize PDF File (Classic).....	383
6.144.1. Colors.....	383
6.144.2. Separations.....	384
6.145. Normalize PostScript / PDF / Illustrator 8.0 File (Classic).....	385
6.145.1. Pages.....	385
6.145.2. Color Management.....	386
6.145.3. Inks.....	388
6.145.4. Overprint.....	389
6.145.5. Images.....	391
6.145.6. Page Size.....	392
6.145.7. Other.....	393
6.145.8. Output.....	395
6.146. Normalize TIFF/IT File (Classic).....	395
6.147. Optimize and Clean (PSFix) (Classic).....	395
6.147.1. General.....	395
6.147.2. Borders.....	398
6.148. Optimize PDF Document (Classic).....	399
6.148.1. Document.....	399
6.148.2. Layers.....	401
6.148.3. Images.....	402
6.149. Optimize PDF Separations (Classic).....	403
6.149.1. Colors.....	403
6.149.2. Inks.....	405
6.149.3. Ink Properties.....	406
6.149.4. Overprints.....	407
6.150. Optimize PDF.....	408
6.150.1. Tab 'Preprocessing'.....	409
6.150.2. Tab 'Color Management'.....	410
6.150.3. Tab 'Processing Step Layers'.....	411
6.150.4. Tab 'Layers'.....	412
6.150.5. Tab 'Separations'.....	413

6.150.6. Tab 'Remove Separations'.....	415
6.150.7. Tab 'Separation Properties'.....	415
6.150.8. Tab 'Document'.....	415
6.150.9. Tab 'Page Boxes'.....	416
6.151. Outline Fonts (Classic).....	417
6.152. Preflight Color for Digital Printing (Ink based).....	417
6.153. Preflight Color for Digital Printing (Content based).....	417
6.154. Preflight Color for Equinox.....	417
6.154.1. Task Parameters.....	419
6.154.2. Preflighting a File's Colors.....	419
6.154.3. Preflight Color for Production.....	424
6.154.4. Preflight Color for Cost Estimation.....	427
6.155. Preflight with PitStop.....	430
6.156. Prefix Products on Esko Cloud.....	430
6.157. Prepare for Inspection.....	430
6.157.1. Settings.....	432
6.158. Prepare for Sharing.....	433
6.159. Prepare for Viewer.....	435
6.160. Prepare for WebCenter Viewer (OBGE).....	435
6.161. Prepare Graphics for Nesting (Classic).....	435
6.162. Prepare Station (Classic).....	435
6.163. Print.....	437
6.164. Print IMP File (Classic).....	437
6.165. Print On Digital Press.....	438
6.166. Process PDF Spreads (Classic).....	438
6.167. Proof for Contract Approval.....	440
6.168. Proof for Content Approval.....	440
6.169. Proof to File - Unscreened.....	440
6.170. Publish Imposition on WebCenter Chain.....	440
6.171. Publish On WebCenter.....	441
6.172. Relocate Job.....	441
6.173. Remove Esko Cloud Link.....	441
6.174. Remove Files from Shared Job.....	441
6.175. Remove Job.....	441
6.176. Remove Product.....	441
6.177. Resize PDF for Output (Classic).....	441
6.177.1. Resizing to a Specific Page Size.....	442
6.177.2. Not Resizing to a Specific Page Size.....	443
6.178. Resize Shape.....	443
6.179. Resolve OPI (Classic).....	445
6.180. Restore Job.....	445
6.181. Reverse Trap.....	445
6.182. Route Approval Cycle.....	446



6.183. Router.....	446
6.184. Run ArtiosCAD Standard.....	446
6.185. Run Script.....	447
6.186. Select File.....	447
6.187. Select Files on Shared Job.....	447
6.188. Select Mark File.....	447
6.189. Select Job.....	447
6.190. Select Product.....	447
6.191. Select Referenced File.....	448
6.192. Send File to Automation Engine Agent.....	448
6.193. Send E-mail.....	448
6.194. Send PostScript File to Device.....	450
6.195. Set Priority.....	450
6.196. Share Job.....	450
6.197. Share Workflow Ticket.....	450
6.198. Sort.....	450
6.199. Split PDF File (Classic).....	450
6.200. Split PDF File.....	451
6.201. Split XML.....	452
6.202. Start Approval Cycle on Share & Approve.....	452
6.203. Step & Repeat CAD based (Classic).....	453
6.203.1. Tab 'General'.....	453
6.203.2. Tab 'CAD Options'.....	454
6.203.3. Tab 'Sheet'.....	455
6.203.4. Tab 'Plate'.....	456
6.204. Step & Repeat CAD based.....	456
6.204.1. Tab 'General'.....	457
6.204.2. Tab 'CAD Layout'.....	459
6.204.3. Tab 'Sheet'.....	460
6.204.4. Tab 'Plate'.....	460
6.204.5. Positioning of a One-up onto a Station.....	461
6.204.6. Distribution of One-ups over the Layout.....	462
6.204.7. About Bleed and Overlapping Bleed.....	463
6.204.8. Using XML as Input File.....	466
6.205. Step & Repeat Tabular (Classic).....	469
6.205.1. Tab 'General'.....	470
6.205.2. Tab 'Plate'.....	472
6.205.3. Tab 'Sheet'.....	473
6.205.4. Tab 'Grids'.....	473
6.205.5. Tab 'Rules'.....	479
6.205.6. Using Formulas.....	480
6.205.7. Using Database Queries: an Example.....	481
6.206. Step & Repeat Tabular.....	483

6.206.1. Assignment of Input Files.....	485
6.206.2. Splitting Output, Blocks and Gaps.....	485
6.206.3. Sheet and Plate Settings.....	487
6.206.4. Filling Order.....	488
6.206.5. Adding Marks.....	491
6.206.6. Specific Grid Options.....	491
6.206.7. Using Formula SmartNames and Calculations.....	492
6.206.8. Specification of RunList XML in Step & Repeat tasks (= excl. the Classic ones).....	496
6.207. Step & Repeat Template based (Classic).....	498
6.208. Step & Repeat Template based.....	500
6.208.1. Using PDF input file(s).....	502
6.208.2. Using RunList XML as input file.....	503
6.208.3. Using JDF as Input File.....	504
6.209. Submit to Flexo CTP Device.....	509
6.210. Submit to Gang Run (Classic).....	509
6.211. Submit to HP SmartStream Production Pro Print Server.....	509
6.212. Submit to Esko DFE.....	510
6.213. Submit to Generic DFE (Pre-Release).....	510
6.214. Submit to Kongsberg Table.....	510
6.215. Submit to Plate Merger.....	510
6.216. Submit XML to Gang Run (Classic).....	510
6.217. Synchronize ArtiosCAD Boards.....	510
6.218. Synchronize ArtiosCAD Companies.....	511
6.219. Track Edit Session.....	511
6.219.1. Viewing the Edit Session Information in the Pilot.....	511
6.219.2. Storing the Editing Information System-Wide.....	512
6.219.3. Which Edit Actions are Logged?.....	513
6.220. Trap.....	514
6.221. Trap with PowerTrapper (Classic).....	516
6.221.1. What is Trapping?.....	517
6.221.2. Distance & Direction.....	517
6.221.3. Color & Shape.....	520
6.221.4. Processing.....	521
6.221.5. Rules.....	522
6.221.6. Output.....	524
6.222. Unshare Job.....	524
6.223. Unzip.....	524
6.224. Upload Files to Shared Job.....	525
6.225. Upload Files to Share & Approve.....	525
6.226. Update Linked Files.....	525
6.227. Upload Product to Esko Cloud.....	525
6.228. Upload via FTP.....	526
6.229. Upload via SFTP.....	526

6.230. Upload To Cloud Storage.....	526
6.231. Verify Certification.....	526
6.232. Version PDF (Classic).....	526
6.233. Wait.....	529
6.234. Wait for Action (Checkpoint).....	529
6.235. Wait for Approval on Share & Approve.....	529
6.236. Wait for Files.....	530
6.237. Wait for Files (via JDF).....	530
6.238. Wait for Product Status.....	530
6.239. Zip.....	531
6.240. Outdated and Soon Outdated Tasks in this Version.....	531
6.240.1. Concept of (Soon) Outdated Tasks / Features.....	531
6.240.2. Expand Variable Data to PPML File (Classic)(Soon Outdated).....	533
6.240.3. Expand Variable Data to PPML File (DeskPack Only)(Classic)(Soon Outdated).....	533
6.240.4. Print on Digital Press (PPML)(Soon Outdated).....	534
6.240.5. Rip to WS4000 Series (Soon Outdated).....	535
6.240.6. FlexRip tasks (Soon outdated).....	535
6.240.7. Tasks that became Outdated in this Version 23.....	537
<b>7. Jobs.....</b>	<b>538</b>
7.1. Job Basics.....	538
7.1.1. The Job Concept.....	538
7.1.2. Types of Jobs.....	539
7.1.3. The Jobs Views.....	540
7.1.4. The Job Menu.....	545
7.2. Creating a Job.....	546
7.3. Job Setup Parameters.....	547
7.3.1. Job tab.....	548
7.3.2. Customer tab.....	551
7.3.3. Inks tab.....	551
7.3.4. Parameters tab.....	553
7.3.5. Barcodes tab.....	557
7.3.6. Step & Repeat tab.....	560
7.3.7. Categorization tab.....	561
7.3.8. Advanced tab.....	562
7.3.9. Sharing tab.....	562
7.3.10. Automation tab (Page workflow).....	563
7.3.11. Page Assignment tab (Page workflow).....	563
7.3.12. Imposition tab (Page workflow).....	564
7.4. About Job Folder Location.....	564
7.4.1. General Note on Data Structure.....	564
7.4.2. FAQs on Job Folder Location.....	565
7.4.3. Good Practices regarding Job Folder Location.....	566
7.5. Uploading Files to Jobs.....	568

7.6. Milestones: Tracking Job Status.....	568
7.6.1. Concept.....	569
7.6.2. The Milestones View.....	569
7.6.3. Adding Milestones to a Job.....	573
7.6.4. Manage (Custom) Milestones.....	574
7.6.5. Working with Milestone Actions.....	575
7.6.6. Using Milestone Statuses to Filter Jobs.....	577
7.6.7. Using Milestones in Workflows: the Manage Milestone Task.....	578
7.6.8. Informing Other Systems of the Milestones Statuses.....	580
7.7. About Removing Jobs.....	581
7.8. Tasks you can Launch on Jobs.....	583
7.8.1. Task 'Relocate Job'.....	584
7.8.2. Task 'Archive Job'.....	585
7.8.3. Task 'Restore Job'.....	587
7.8.4. Task 'Check Job and Product Parameters'.....	589
7.8.5. Task 'Check Job Parameters (Classic)'.....	590
7.8.6. Task 'Remove Job'.....	592
7.8.7. Task 'Change Location of Jobs'.....	593
7.9. Automated Creation of Jobs.....	593
<b>8. Products.....</b>	<b>594</b>
8.1. Products Basics.....	594
8.1.1. The Products Concept.....	594
8.1.2. Global Products and Job Products.....	597
8.1.3. Products can have Multiple Parts.....	598
8.2. Products Data Structure.....	599
8.2.1. Examples of Data Zone Depth.....	601
8.3. Products Views and Menu.....	605
8.3.1. The Products Gallery View.....	605
8.3.2. The Product(s) in a Job View.....	609
8.3.3. The Product Menu.....	610
8.4. Product (Part) Properties.....	611
8.4.1. Product Setup.....	612
8.4.2. Product Part Setup.....	614
8.5. Creating Products.....	616
8.5.1. Creating Products Manually.....	616
8.5.2. Uploading As a New Product.....	617
8.5.3. Creating Products Automatically.....	617
8.5.4. Creating Products via JDF/JMF.....	622
8.6. Linking Products to a Job.....	622
8.7. Launching Tasks on Products.....	623
8.8. Working with Products in Editors.....	623
8.9. Tasks specific for Products.....	626
8.9.1. Task 'Add to Products'.....	626

8.9.2. Task 'Link Product to Job'.....	628
8.9.3. Task 'Remove Product'.....	629
8.9.4. Task 'Manage Product Status'.....	630
8.9.5. Task 'Wait for Product Status'.....	630
8.9.6. Task 'Check Job and Product Parameters'.....	632
8.9.7. Task 'Check Product Parameters (Classic)'.....	632
8.9.8. Task 'Change Location of Products'.....	633
8.10. Publishing Products to WebCenter.....	633
8.11. Backing Up and Archiving Products.....	634
8.12. Removing Products.....	635
<b>9. SmartNames.....</b>	<b>637</b>
9.1. Concept.....	637
9.2. General Principles.....	639
9.2.1. Using a SmartName.....	639
9.2.2. The SmartNames View.....	641
9.2.3. SmartName Types (Overview).....	644
9.2.4. SmartName Categories.....	646
9.2.5. SmartName Scopes.....	648
9.2.6. SmartName Tags.....	649
9.2.7. Creating a SmartName (General).....	651
9.2.8. Testing SmartNames.....	652
9.2.9. SmartName Relations and Dependencies.....	657
9.2.10. Exporting and Importing SmartNames.....	660
9.3. System (Value) SmartNames.....	661
9.3.1. Default System SmartNames.....	661
9.3.2. Creating System Value SmartNames.....	667
9.4. String Extract SmartNames.....	671
9.4.1. Creating a String Extract SmartName.....	671
9.5. CSV Text Extract SmartNames.....	674
9.5.1. Creating a CSV Text Extract SmartName.....	674
9.5.2. Example.....	675
9.6. XPath Query SmartNames.....	676
9.6.1. Creating an XPath Query SmartName.....	677
9.6.2. The XPath Builder.....	678
9.7. XMP XPath Query SmartNames.....	682
9.7.1. Creating an XMP XPath Query SmartName.....	683
9.7.2. Examples.....	684
9.8. Conditional SmartNames.....	686
9.8.1. Creating a Conditional SmartName (generic).....	686
9.8.2. Setting up a Conditional Block.....	687
9.8.3. Examples.....	689
9.9. Database Query SmartNames.....	692
9.9.1. Concept.....	692

9.9.2. Creating a Database Query SmartName.....	693
9.10. Script SmartNames.....	694
9.10.1. Creating a Script SmartName.....	695
9.10.2. Examples.....	695
9.11. Formatting SmartNames.....	696
9.11.1. Text Formatting.....	696
9.11.2. Number Formatting.....	698
9.11.3. Date and Time Formatting.....	699
9.12. Using Regular Expressions.....	702
9.12.1. A Selection of Useful Characters in Regular Expressions.....	703
9.12.2. Using Parentheses to Extract.....	704
9.12.3. Examples from Users.....	705
9.12.4. The RegEx Builder.....	707
9.13. SmartNames of Parameter Values.....	729
<b>10. Workflows.....</b>	<b>733</b>
10.1. Workflow Basics.....	733
10.2. Building Workflows using the Workflow Editor.....	734
10.2.1. The Workflow Editor Window.....	734
10.2.2. The Workflow Editor Menus.....	735
10.2.3. The Workflow Editor Tool Bar.....	737
10.2.4. Building a Workflow from Scratch.....	738
10.2.5. Building a Workflow using Custom Tickets.....	741
10.2.6. Configuring Output Statuses.....	743
10.2.7. Visual Optimizations of a Workflow.....	744
10.2.8. Subworkflows.....	747
10.2.9. Inserting Wait Points.....	750
10.2.10. Routing in Workflows.....	769
10.2.11. Exchanging Workflows.....	772
10.2.12. Good Practices for Building Workflows.....	773
10.3. Launching and Diagnosing Workflows.....	780
10.3.1. The Parameter Inspector.....	780
10.3.2. Launching a Workflow on a File.....	781
10.3.3. Using Favorite Workflow Tickets.....	783
10.3.4. Building and Launching a Workflow On The Fly.....	788
10.3.5. General Workflow Task Options.....	789
10.3.6. Relaunching Your Workflow with Different Settings.....	790
10.3.7. Diagnosing a Workflow in the Tasks Pane.....	790
10.3.8. Diagnosing a Workflow in the Workflow Editor.....	792
10.3.9. Understanding Tokens (Grouping of Output Files).....	796
10.3.10. Searching Parameters in a Workflow.....	799
10.3.11. Checking a Workflow's Warnings.....	800
10.3.12. Checking the Resources your Workflow contains.....	803
10.3.13. Pausing or Cancelling Your Workflow.....	805

10.4. Workflow Controls.....	805
10.4.1. Launch Workflow.....	806
10.4.2. Modify Workflow Parameter Values.....	808
10.4.3. Router.....	811
10.4.4. Select File.....	817
10.4.5. Select Job.....	819
10.4.6. Select Product.....	820
10.4.7. Select Referenced File.....	821
10.4.8. Set Priority.....	824
10.4.9. Sort.....	825
10.4.10. Mark File and Select Marked File.....	828
10.4.11. Data Collector.....	829
10.4.12. Data Splitter.....	835
10.4.13. Fork and Join.....	837
10.5. Using Public Parameters in Workflows.....	838
10.5.1. Concept.....	838
10.5.2. Creating Public Parameters in a Workflow.....	840
10.5.3. Conditional Availability of Public Parameters.....	841
10.5.4. Managing Public Parameters in a Workflow.....	847
10.5.5. Making Presets to Simplify the Users' Choices.....	849
10.5.6. Example of Further Customizing the Public Parameters Dialog.....	852
10.5.7. Launching a Workflow with Public Parameters.....	856
10.6. Using Workflow Parameters.....	859
10.6.1. Concept.....	859
10.6.2. Most Typical Use Cases for Using Workflow Parameters.....	862
10.6.3. Creating Workflow Parameters Manually.....	863
10.6.4. Loading Workflow Parameters from XML.....	864
10.6.5. Using Workflow Parameters.....	865
10.6.6. Using Workflow Parameter Values from XML.....	866
10.6.7. Changing the Value of a Workflow Parameter.....	868
10.6.8. Modifying Workflow Parameters During a Workflow.....	870
10.7. Automated Launching of Workflows.....	871
10.8. Migrating Old Task Chains.....	872
<b>11. Working with Shuttle.....</b>	<b>875</b>
11.1. What is Shuttle?.....	875
11.2. Installing Shuttle.....	876
11.3. Shuttle Setup.....	876
11.3.1. Configuring Shuttle in Automation Engine.....	876
11.3.2. Making Tickets Public.....	877
11.3.3. Shuttle Clients connecting from Editors.....	877
11.3.4. Shuttle Application connecting to Automation Engine.....	878
11.4. Launching the Automation Engine Shuttle.....	878
11.5. Working with the Automation Engine Shuttle.....	879

11.5.1. The Tasks Panel.....	880
11.5.2. The Launch Panel.....	881
11.5.3. Launching a Workflow from the Automation Engine Shuttle.....	882
11.5.4. User Intervention managed from Shuttle.....	884
<b>12. Browser Client Workspaces.....</b>	<b>886</b>
12.1. Introducing the Browser Client.....	886
12.2. Browsing to your AE server.....	887
12.2.1. Signing In.....	887
12.2.2. Can I Use Domain Users?.....	888
12.2.3. Can I use the Browser Client from Outside my Network?.....	889
12.3. Basic features used in every workspace.....	889
12.3.1. Advanced ways to Search and Filter.....	889
12.3.2. User Preferences.....	891
12.4. Workspace 'My Workspace'.....	891
12.4.1. Concept.....	891
12.4.2. See the eLearning Modules.....	892
12.4.3. Jobs page.....	892
12.4.4. Products page.....	893
12.4.5. Context Selection tool.....	893
12.4.6. Drop File page.....	893
12.4.7. Files page.....	893
12.4.8. Activity page.....	895
12.4.9. To Do page.....	896
12.4.10. User page.....	896
12.4.11. Notifications slide-out.....	896
12.5. Workspace 'Roll-Fed Labels'.....	897
12.5.1. Concept.....	897
12.5.2. See the eLearning Modules.....	897
12.5.3. Post-Install Configuration.....	897
12.5.4. Details of the Product's Preparation workflow.....	901
12.5.5. Customization.....	905
12.5.6. Frequently Asked Questions.....	907
12.6. ADMIN page.....	913
<b>13. ArtPro automation - ArtPro Action Lists.....</b>	<b>914</b>
13.1. Automating ArtPro Processing.....	914
13.2. The ArtPro Action List Editor.....	914
13.2.1. Installing the ArtPro Action List Editor.....	914
13.2.2. Working with ArtPro Action Lists.....	915
13.3. Handling Fonts in ArtPro Files.....	916
13.4. The Apply ArtPro Action List Task (Classic).....	918
13.4.1. Using SmartNames in the Apply ArtPro Action List task.....	918
13.5. Available Actions.....	919



13.5.1. Adjust Stroke Width.....	919
13.5.2. Apply Pictures.....	920
13.5.3. ArtLink.....	920
13.5.4. Borders.....	923
13.5.5. Certified PDF.....	923
13.5.6. Clip.....	924
13.5.7. Clip to Border.....	924
13.5.8. Close ArtPro File.....	924
13.5.9. Create ArtPro File.....	924
13.5.10. Create Layer.....	924
13.5.11. Delete.....	925
13.5.12. Difference.....	925
13.5.13. Export CIP3.....	926
13.5.14. Export Illustrator.....	926
13.5.15. Export Macroflex.....	926
13.5.16. Export Mount-O-Matic.....	926
13.5.17. Export PDF.....	926
13.5.18. Export Picture List.....	927
13.5.19. Fit Borders.....	927
13.5.20. Fit to Border.....	927
13.5.21. Fit to Paper.....	927
13.5.22. Fix Thin Parts.....	928
13.5.23. Flatten Transparencies.....	928
13.5.24. Full Step and Repeat.....	928
13.5.25. Generate Marks.....	929
13.5.26. Generate Strokes.....	929
13.5.27. Gravure Job Ticket.....	929
13.5.28. Gravure Tiff.....	930
13.5.29. Grid Step and Repeat.....	930
13.5.30. Gridwarp.....	930
13.5.31. Import Picture List.....	930
13.5.32. Importing.....	930
13.5.33. Ink Coverage.....	937
13.5.34. Ink Coverage Check.....	937
13.5.35. Insert ArtPro file.....	937
13.5.36. Join.....	938
13.5.37. Layer Versioning.....	938
13.5.38. Make Compound.....	939
13.5.39. Make Thumbnail.....	939
13.5.40. Modify Layers.....	939
13.5.41. Modify Paint.....	940
13.5.42. Modify Screen.....	940
13.5.43. Modify Separations.....	940

13.5.44. Move Ruler.....	941
13.5.45. Nested Step and Repeat.....	941
13.5.46. Open ArtPro File.....	942
13.5.47. OPI Generation.....	943
13.5.48. Optimizing.....	943
13.5.49. PowerTrapper.....	944
13.5.50. Print to File.....	944
13.5.51. PrintCheck.....	944
13.5.52. Regmarks.....	944
13.5.53. Reorder Layers.....	945
13.5.54. Reorder Separations.....	945
13.5.55. Rich Black.....	945
13.5.56. Save ArtPro File.....	945
13.5.57. Select File.....	946
13.5.58. Select Objects.....	947
13.5.59. Separate.....	949
13.5.60. Set Station Numbers.....	949
13.5.61. Spread.....	949
13.5.62. Tabular Step and Repeat.....	950
13.5.63. Text to Paths.....	950
13.5.64. Transform.....	950
13.5.65. Trim & Bleed.....	951
13.5.66. Unite.....	951
13.5.67. Update ArtLink.....	951
13.5.68. Vector Trapping.....	952
13.5.69. Vectorize File.....	952
13.5.70. White Underprint.....	952
<b>14. Sign &amp; Display Workflow.....</b>	<b>953</b>
14.1. Typical features of Sign & Display Printing.....	953
14.1.1. Nesting.....	953
14.1.2. Ganging.....	954
14.1.3. Tiling.....	954
14.2. Two modes: Nesting Queues or Nesting Task.....	956
14.3. Preparation Tasks.....	958
14.3.1. Prepare Graphics for Nesting (Classic).....	958
14.3.2. Create Tiles (Classic).....	964
14.4. In-Workflow Nesting Tasks.....	975
14.4.1. Add Parameters for Nesting (Classic).....	975
14.4.2. Create Nested Layouts (Classic).....	976
14.5. Working with Gang Run Printing Substrate Queues.....	977
14.5.1. Preparing and Submitting your Graphics (Input Workflow).....	978
14.5.2. Creating Gang Run Layouts on the Nesting Server.....	980
14.5.3. Getting Production Files out of your Gang Run Layout(s)(Output Workflow).....	984

14.6. The Gang Run Printing View.....	984
14.6.1. Working with Substrate Queues.....	985
14.6.2. Working with Substrate Queue Entries.....	1000
14.6.3. Viewing and Choosing Nested Layouts.....	1004
14.7. The Gang Run Printing Tasks.....	1008
14.7.1. Import Gang Run Substrate Sizes from XML.....	1008
14.7.2. Submit to Gang Run (Classic).....	1013
14.7.3. Submit XML to Gang Run (Classic).....	1020
14.7.4. Export Gang Run Layouts (Classic).....	1030
14.8. Automating your Workflow Using XML.....	1043
14.9. The Orders View.....	1044
14.10. Examples.....	1048
14.10.1. Basic workflow using the Shuttle.....	1048
14.10.2. Working with Grouping Keys.....	1058
14.10.3. Basic XML driven workflow.....	1070
<b>15. Quality Control tools.....</b>	<b>1077</b>
15.1. Concept and Overview.....	1077
15.2. Automation Engine Viewer.....	1077
15.2.1. Intro, Technologies and Formats.....	1077
15.2.2. User Interface (Pilot - Java version).....	1084
15.2.3. User Interface (Browser client - Latest technology).....	1084
15.2.4. How To (Top Tools Bar).....	1088
15.2.5. Navigator tool.....	1100
15.2.6. View tool.....	1100
15.2.7. Channels tool.....	1105
15.2.8. CAD tool.....	1108
15.2.9. Info tool.....	1108
15.2.10. Layers tool.....	1109
15.2.11. Color Management tool.....	1109
15.2.12. Quality Control tools.....	1110
15.2.13. Comparing Files.....	1117
15.2.14. Working with Prepared View Data.....	1129
15.2.15. Working with RIP data.....	1133
15.2.16. Working with 3D.....	1135
15.2.17. Working with Annotations.....	1139
15.2.18. Working with Multi-Page Files.....	1143
15.2.19. Keyboard Shortcuts (latest technology - browser).....	1145
15.3. PitStop Preflight.....	1146
15.3.1. Preflight Concept.....	1146
15.3.2. The PitStop Profile Editor.....	1147
15.3.3. Preflight with PitStop Task.....	1149
15.3.4. Verify Certification Task.....	1155
15.4. GlobalVision Inspection Tasks.....	1155

15.4.1. Introduction.....	1155
15.4.2. Recurring Options in GlobalVision Tasks.....	1156
15.4.3. Inspection Results as Annotations in Viewers.....	1159
15.4.4. Inspect Artwork.....	1161
15.4.5. Inspect Barcodes.....	1164
15.4.6. Inspect Braille.....	1171
15.4.7. Inspect Spelling.....	1173
15.4.8. Inspect Text.....	1174
15.4.9. GlobalVision Profile Editor (OUTDATED).....	1175
15.5. Other QC Tasks.....	1175
15.5.1. Check Print Rules (PRC) (Classic).....	1175
15.5.2. Compare PDF (Classic).....	1176
<b>16. RIP'ing with Imaging Engine.....</b>	<b>1178</b>
16.1. What is Imaging Engine?.....	1178
16.2. Using Imaging Engine for Proofing and RIP'ing.....	1178
16.3. What Does Imaging Engine Do?.....	1179
16.3.1. Color Management.....	1180
16.3.2. Rendering.....	1187
16.3.3. Screening.....	1192
16.3.4. Dot Gain Compensation.....	1219
16.3.5. File Formats.....	1224
16.3.6. Calculating Ink Distribution.....	1227
16.4. Imaging Engine Installation and Configuration.....	1228
16.4.1. Licensing.....	1228
16.4.2. Installation.....	1228
16.4.3. Configuration in the Automation Engine Pilot.....	1253
16.5. The Imaging Engine Tasks.....	1257
16.5.1. Proof for Content Approval.....	1258
16.5.2. Image to Content Proof (RGB).....	1280
16.5.3. Image to Unscreened Proof.....	1299
16.5.4. Image to Screened Separations.....	1330
16.5.5. Image to Unscreened Separations.....	1399
16.5.6. Calculate Ink Key Settings (CIP3).....	1440
16.6. Third Party Licenses - Imaging Engine.....	1470
<b>17. Flexo CTP Device Workflow.....</b>	<b>1482</b>
17.1. Intro.....	1482
17.1.1. CDI (LEN, LENX) or Not CDI (TIFF).....	1482
17.1.2. Terminology.....	1483
17.1.3. Manual Workflow (DFS only).....	1484
17.1.4. Automatic workflow (using AE).....	1485
17.1.5. Semi-Automatic Workflow (manual intervention).....	1486
17.1.6. Introducing Flexo CTP Device related Views and Tasks.....	1487

17.1.7. Main Steps in Setting Up this Workflow.....	1488
17.1.8. Reporting to Business Systems.....	1489
17.1.9. Removed CDI Related Tools.....	1489
17.2. Flexo Device related Views.....	1490
17.2.1. Devices (CDI).....	1490
17.2.2. Devices (TIFF).....	1494
17.2.3. Press Plates.....	1496
17.2.4. Press Plate Sets.....	1499
17.2.5. Plate Merger.....	1501
17.2.6. Merged Plates.....	1532
17.2.7. Device Queues.....	1537
17.3. Flexo Device related Tasks.....	1540
17.3.1. Add Margins to LEN file task.....	1540
17.3.2. Apply Plate ID to LENX file.....	1541
17.3.3. Create Flexo Plate Cutting Paths.....	1541
17.3.4. Crop LEN File task.....	1542
17.3.5. Submit to Plate Merger task.....	1544
17.3.6. Create Merged Plate task.....	1548
17.3.7. Submit to Flexo Device task.....	1548
17.4. Using the DFS Merger in AE mode.....	1549
17.4.1. Creating a SmartName for the Merged Plate output File and Queue Entry.....	1552
17.5. FAQs.....	1553
17.6. Working with Plate ID.....	1554
17.6.1. Concept and Workflow Overview.....	1554
17.6.2. Requirements.....	1556
17.6.3. Adding Plate ID Objects in ArtPro+ (Summary).....	1557
17.6.4. Applying the Metadata into the LENX file.....	1559
17.6.5. Specifics in the AE Plate Merger.....	1559
17.6.6. Setup in DFS and Testing.....	1560
17.6.7. FAQs.....	1560
17.7. Working with Solvent Saver.....	1561
17.8. XML technical details.....	1562
17.8.1. Interpreting the Reporting XML files.....	1562
<b>18. Kongsberg Production Workflow.....</b>	<b>1565</b>
18.1. Intro.....	1565
18.1.1. Workflow Overview and Types.....	1565
18.1.2. Submitting Single CAD Files.....	1566
18.1.3. Submitting Nested Layouts.....	1567
18.1.4. Cutting CDI plates.....	1568
18.2. Kongsberg Related Views.....	1571
18.2.1. Devices (Kongsberg).....	1571
18.2.2. Table Queues.....	1572
18.2.3. Sheets.....	1576

18.2.4. Orders.....	1578
18.3. Kongsberg Related Tasks.....	1579
18.3.1. Submit To Kongsberg Table task.....	1579
18.3.2. Export Kongsberg Cutting History.....	1580
18.4. Workflow Example.....	1582
18.4.1. Step 1 - The Order.....	1582
18.4.2. Step 2a - Submitting the PDF to the Gang Run.....	1583
18.4.3. Step 2b - First Appearance in the Orders View.....	1584
18.4.4. Step 3 - Quantity vs. Layouts.....	1585
18.4.5. Step 4 - Files Created.....	1585
18.4.6. Step 5 - Each JDF is a Job entry in the Table Queues view.....	1586
18.4.7. Step 6 - Logos are Printed and Moved to the Table.....	1587
18.4.8. Step 7 - The iPC Operator Produces the Jobs.....	1587
18.4.9. Step 8 - The Sheets View shows the Production Results.....	1588
<b>19. Digital Printing Workflow.....</b>	<b>1589</b>
19.1. Intro.....	1589
19.2. Devices (Digital Presses).....	1589
19.3. Tasks related to Digital Printing.....	1591
19.3.1. Convert Colors for Digital Printing (Classic).....	1591
19.3.2. Preflight Color for Digital Printing (Ink based).....	1594
19.3.3. Preflight Color for Digital Printing (Content based).....	1613
19.3.4. Print on Digital Press.....	1614
19.3.5. Submit to Esko DFE.....	1627
19.3.6. Submit to HP SmartStream Production Pro Print Server.....	1628
19.3.7. Submit to Generic DFE (PRE-RELEASE).....	1629
19.4. Using Shared Resources between AE and the DFE.....	1629
19.4.1. Using Shared Resources for Newly Installed Applications.....	1630
19.4.2. Using Shared Resources for Existing Applications.....	1631
<b>20. AE SaaS: When your AE is in a Data Center.....</b>	<b>1633</b>
20.1. SaaS Concept and Setups.....	1633
20.1.1. Not available in SaaS (only in On-Premises).....	1634
20.1.2. FAQs.....	1635
20.2. SaaS Technology Components.....	1635
20.2.1. How the Pilot client Adapts to a SaaS Connection.....	1636
20.2.2. The Agent.....	1637
20.3. Extra Functionality in SaaS.....	1642
20.3.1. Agent Folder Access Point.....	1642
20.3.2. Task 'Send File to Automation Engine Agent'.....	1646
20.3.3. Adding a Local Device.....	1647
20.4. Storing Inactive Jobs on Esko Cloud.....	1648
20.4.1. Concept and Configuration.....	1648
20.4.2. The View 'Inactive Jobs'.....	1649

20.4.3. Task 'Move Job to Inactive Jobs'.....	1652
20.4.4. Task 'Move Inactive Job to Jobs'.....	1653
20.4.5. Task 'Copy Inactive Job to Jobs'.....	1654
20.4.6. Task 'Delete Inactive Job'.....	1655
20.4.7. Automating the moving of Jobs.....	1656
20.4.8. Task 'Change Location of Inactive Jobs'.....	1658
20.5. Storing Products on Esko Cloud.....	1658
20.5.1. Concept and Configuration.....	1658
20.5.2. The View 'Products on Esko Cloud'.....	1659
20.5.3. Task 'Upload Product to Esko Cloud'.....	1663
20.5.4. Task 'Download Product from Esko Cloud'.....	1664
20.5.5. Task 'Delete Product on Esko Cloud'.....	1665
20.5.6. Task 'Change Location of Products on Esko Cloud'.....	1665
20.6. Using Esko Cloud for Color Data.....	1666
20.6.1. Preparation and Configuration.....	1667
20.7. Editor Connection Tools.....	1669
20.7.1. The App Launcher Tool (SaaS + On-Premises).....	1669
20.7.2. The Syncer Tool.....	1670
20.8. Local Editing Applications in a SaaS workflow.....	1674
20.9. Migrating from an On-Premises AE to a SaaS setup.....	1675
20.10. Filtering on Locations after consolidating all data.....	1676
20.11. Integrating with (multiple) MIS.....	1679
20.11.1. Working with Agent Prefixes in JDF/JMF integrations.....	1681
20.11.2. Task 'Prefix Products on Esko Cloud'.....	1683
<b>21. Sharing to Collaborate with other AE servers.....</b>	<b>1685</b>
21.1. Concept and Terminology.....	1685
21.1.1. What is Esko Cloud?.....	1685
21.1.2. Concept of Collaborating Automation Engines.....	1686
21.1.3. What is a Group? What is a Location?.....	1687
21.1.4. What is Uploading? What is Sharing?.....	1687
21.2. The Importance of Standardization between Locations.....	1688
21.3. Setup and initial Configuration.....	1690
21.3.1. Required Esko Products.....	1690
21.3.2. Initial Configuration.....	1690
21.4. Tools and Tasks.....	1696
21.4.1. On Customers.....	1697
21.4.2. On Files in Jobs.....	1704
21.4.3. On Jobs.....	1705
21.4.4. On (Workflow) Tickets.....	1714
21.4.5. Job Sharing Access Point.....	1718
21.4.6. SmartNames related to Sharing via Esko Cloud.....	1720
21.5. FAQs on Technical Setup.....	1720
21.6. FAQs and Tips on Customer Consolidation.....	1722

21.7. FAQs on Collaboration Workflow.....	1725
21.8. FAQs on Tickets on Esko Cloud.....	1728
21.9. Workflow Examples - Combing the Tools and Tasks.....	1729
21.9.1. EXA 1 - Delegating work to an Other Location.....	1729
21.9.2. EXA 2 - Notify Users about Problems with Jobs arriving from Esko Cloud.....	1732
21.9.3. EXA 3 - Notify Users that Files have Arrived from Esko Cloud.....	1738
21.9.4. EXA 4 - Automatically sending the result data back to location that requested it.....	1740
<b>22. Integrating with WebCenter.....</b>	<b>1741</b>
22.1. Introduction.....	1741
22.2. WebCenter Sites.....	1742
22.3. The WebCenter View in Automation Engine Pilot.....	1744
22.4. WebCenter Integration Tasks.....	1745
22.4.1. Task 'Create or Modify WebCenter Project'.....	1745
22.4.2. Task 'Publish on WebCenter'.....	1748
22.4.3. Task 'Download WebCenter Document'.....	1756
22.5. Advanced WebCenter Integration.....	1758
22.5.1. Task 'Integrate with WebCenter'.....	1758
<b>23. Integrating with Share &amp; Approve.....</b>	<b>1762</b>
23.1. What is Share & Approve?.....	1762
23.2. Task 'Upload Files to Share & Approve'.....	1762
23.3. Task 'Start Approval Cycle on Share & Approve'.....	1764
23.4. Task 'Wait for Approval on Share & Approve'.....	1766
23.5. Task 'Remove Esko Cloud Link'.....	1766
23.6. Routing an Approval Cycle.....	1767
23.7. FAQs.....	1768
<b>24. Integrating with External Systems.....</b>	<b>1769</b>
24.1. Introduction.....	1769
24.1.1. Why Integrate?.....	1769
24.1.2. External System sending commands To Automation Engine.....	1770
24.1.3. Automation Engine sending commands To an External System.....	1770
24.1.4. Some general advice.....	1770
24.1.5. Need any help?.....	1771
24.1.6. What about JDF?.....	1771
24.2. Integration Concepts.....	1771
24.2.1. AE Access Points Triggering a Workflow on Automation Engine.....	1772
24.2.2. AE tasks Interacting directly with the External System.....	1773
24.2.3. AE Mapper tasks Transforming Data.....	1774
24.2.4. AE sending data Back to the External System.....	1776
24.3. Access Points.....	1777
24.3.1. Folder Access Point.....	1780
24.3.2. FTP Access Point.....	1782
24.3.3. SFTP Access Point.....	1785



24.3.4. E-Mail Access Point.....	1786
24.3.5. Gmail Access Point.....	1789
24.3.6. Exchange Access Point.....	1790
24.3.7. Scheduled Access Point.....	1790
24.3.8. Database Access Point.....	1791
24.3.9. Web Service Access Point.....	1794
24.3.10. Job Sharing Access Point.....	1803
24.3.11. Cloud Storage Access Point.....	1803
24.3.12. SAP Access Point.....	1806
24.3.13. Agent Folder Access Point.....	1806
24.4. Upload tasks.....	1806
24.4.1. Task 'Upload via FTP'.....	1806
24.4.2. Task 'Upload via SFTP'.....	1808
24.4.3. Task 'Upload To Cloud Storage'.....	1809
24.5. Data Transforming Tasks.....	1811
24.5.1. Task 'Convert JSON to XML'.....	1811
24.5.2. Task 'Convert XML to JSON'.....	1813
24.5.3. Task 'Create XML File'.....	1814
24.5.4. Task 'Map Data'.....	1815
24.5.5. Task 'Join XML Files'.....	1828
24.5.6. Task 'Split XML File'.....	1832
24.6. Tasks Interacting with other Systems.....	1842
24.6.1. Task 'Interact using JDF'.....	1842
24.6.2. Task 'Interact using JMF'.....	1843
24.6.3. Task 'Interact with Database'.....	1843
24.6.4. Task 'Interact with SAP'.....	1846
24.6.5. Task 'Interact with Web Service'.....	1846
24.7. Tasks often used in Integration Workflows.....	1850
24.7.1. Task 'Create Job'.....	1850
24.7.2. Task 'Add To Products'.....	1857
24.7.3. Task 'Link Product To Job'.....	1857
24.8. Examples.....	1858
24.8.1. Creating a Job using XML.....	1858
24.8.2. Creating Multiple Jobs from One XML.....	1867
24.8.3. Create Multiple Jobs from a CSV file.....	1871
24.8.4. Creating Jobs using a Database Access Point.....	1881
24.8.5. Launching a workflow with parameters from an XML.....	1889
24.8.6. Getting info from a Web Service into a Workflow.....	1901
24.8.7. Updating a Product Status in an External System via Interact with Database.....	1909
<b>25. Using Scripts.....</b>	<b>1917</b>
25.1. Scripting Concept.....	1917
25.2. The Script Runner Tool.....	1918
25.3. Installing Script Runner.....	1919

25.4. Configuring Script Runner.....	1920
25.5. The Run Script Task.....	1922
25.6. Script Runner on macOS - Examples.....	1924
25.6.1. AppleScript - Example 1.....	1924
25.6.2. AppleScript - Example 2.....	1928
25.6.3. Shell Script - Example.....	1931
25.7. Script Runner on Windows - Examples.....	1935
25.7.1. Windows Script Example 1.....	1935
25.7.2. Windows Script Example 2.....	1938
25.7.3. Batch File Example.....	1941
25.8. Using ExtendScript (macOS & Windows).....	1945
25.8.1. Adobe Applications on Windows: Run Script Runner as an Application (Not as a Service)....	1945
25.8.2. ExtendScript in Adobe Illustrator - Example 1.....	1945
25.8.3. ExtendScript in Adobe Illustrator - Example 2.....	1948
25.8.4. ExtendScript in Adobe Photoshop - Example.....	1951
25.9. PowerShell Examples (macOS & Windows).....	1953
25.10. Scripting Samples.....	1954
<b>26. How to ...?.....</b>	<b>1955</b>
26.1. How to Work with Technical Inks (Normalized PDF).....	1955
26.2. Hybrid Press Workflow.....	1957
26.2.1. Concept of Hybrid Printing.....	1957
26.2.2. What is the Problem?.....	1957
26.2.3. How to define the Printing Method of a Separation?.....	1957
26.2.5. How to Differentiate the Processing of Separations for Different Printing Methods?.....	1960
26.3. Integrating with Nexus (outdated).....	1961
26.4. Integrating with Odystar (outdated).....	1961
<b>27. Pre-Install IT Requirements.....</b>	<b>1962</b>
27.1. Introduction.....	1962
27.2. Technical Details.....	1962
27.2.1. Automation Engine in its environment.....	1962
27.2.2. Automation Engine installation.....	1963
27.2.3. Network Details.....	1966
27.2.4. Database server.....	1967
27.2.5. File Server.....	1969
27.2.6. Mail Server.....	1969
27.2.7. Users and Groups.....	1969
27.2.8. The Automation Engine Pilot.....	1975
27.2.9. The Automation Engine Web Service.....	1975
27.3. General Guidelines.....	1975
27.3.1. Scalability and Performance (AE server on-premises).....	1975
27.3.2. Snapshots/Cloning.....	1981
27.3.3. Installing Other Applications on the Automation Engine server computer.....	1981

<b>28. Installation Guide.....</b>	<b>1982</b>
28.1. How to Install Automation Engine 23.....	1982
28.1.1. Before installing Automation Engine.....	1982
28.1.2. Types of Installations.....	1983
28.1.3. How to Perform the Automation Engine 23 System Readiness Check.....	1983
28.1.4. How to Install the Esko License Server.....	1984
28.1.5. How to Install the Automation Engine Prerequisite Components.....	1984
28.1.6. How to Install Automation Engine 23.....	1985
28.1.7. How to Install Pilot or Shuttle.....	1988
28.1.8. How to Open a Browser Client.....	1990
28.2. How to Create a full Backup of Automation Engine 23.....	1991
28.3. How to Upgrade to Automation Engine 23.....	1991
28.3.1. Before Upgrading to Automation Engine 23.....	1991
28.3.2. How to Perform the Automation Engine 23 System Readiness Check.....	1992
28.3.3. How to upgrade the Esko License Server Components.....	1992
28.3.4. How to Upgrade the Prerequisite Components.....	1993
28.3.5. How to Upgrade Automation Engine software.....	1993
28.4. How to Upgrade onto a New Server Computer.....	1994
28.5. How to Repair an Automation Engine Server.....	1994
28.6. How to Uninstall Automation Engine server software.....	1995
28.7. How to Install the Configuration Manager.....	1996
<b>29. Automation Engine Server Management.....</b>	<b>1997</b>
29.1. The AE Server CONFIG web page.....	1997
29.1.1. The Get Started page.....	1997
29.1.2. Server Config section.....	1998
29.1.3. Server Admin section.....	2009
29.2. The AE Server ADMIN web page.....	2009
29.2.1. Status Overview.....	2010
29.2.2. Server Activity.....	2010
29.2.3. Server Setup.....	2011
29.2.4. Processing Capabilities.....	2015
29.2.5. System Account.....	2018
29.2.6. Maintenance.....	2019
29.2.7. Backup.....	2020
29.2.8. Restore.....	2023
29.2.9. Databases.....	2025
29.2.10. SQL Server.....	2029
29.2.11. My Workspace.....	2031
29.2.12. About.....	2031
29.2.13. Server Checks.....	2032
29.3. The AE Browser Client ADMIN page.....	2039
29.3.1. Usage Dashboard.....	2039
29.3.2. Manage Tokens (SaaS only).....	2053

29.3.3. Manage Fonts..... 2054

29.3.4. Load History..... 2055

29.3.5. View Sessions..... 2057

29.3.6. Agents (SaaS only)..... 2057

29.3.7. System History..... 2058

**30. Troubleshooting.....2060**

30.1. Alerts.....2060

30.2. Troubleshooting the Server..... 2060

30.3. Troubleshooting the Pilot..... 2061

30.4. Troubleshooting the Software..... 2063

**31. Copyright Notice.....2065**

31.1. Third Party Licenses - Automation Engine.....2066

# 1. What's New?

---

## 1.1. What's New in this Version?

---

You can find all information about changes in this version in these documents:

- On <https://www.esko.com/en/Support/Product?id=Automation%20Engine>, you can find
  - The **What's New?** PDF
  - The **Release Notes** PDF, a more technical description of all changes, including a list of the Esko support tickets that were solved in this version.
- <http://www.esko.com/systemrequirements> includes updated information on the system requirements.
- All information about "**(soon) outdated tasks**" is part of this manual. Find it at the end of the chapter *Task and Workflow Controls*, at the bottom of the list with all the types of tasks. Here's a direct link: [Outdated and Soon Outdated Tasks in this Version](#) on page 531.

## 2. Introducing Automation Engine

---

### 2.1. What is Automation Engine?

---

**Automation Engine** serves to increase productivity of prepress workflows. It does this through automated workflows, data management and quality control tools.

Automation Engine is one of many **Esko Software** applications that serve various segments of the packaging and printing industry.

#### 2.1.1. Client-Server Architecture

- **Server:**

The Automation Engine server is where all background actions are executed. This is also where the main configuration and databases are stored. This server is a powerful computer running on Windows Server OS.

- **Clients**

- **Pilot:**

The most known client application is the Automation Engine **Pilot**. You can install a Pilot on macOS or Windows computers in the LAN network of the server.

The Pilot is the main interface for many users. This is where they inspect files and launch and manage tasks on the server. Depending on the user's **Access Rights**, more setup and configuration tools become available. Administrators will set up and prepare workflows using the Pilot.

- **Browser client:**

Most of the daily use of Automation Engine can also be done from a browser page that connects to the AE server. This type of client connection is available since AE 21.

- **Shuttle:**

Some customers prefer to use the client application **Shuttle**. This tool offers a more limited interface where you can simply drag and drop files to launch the same kind of workflows on the server.

- **From within an editor application:**

Users that work with interactive applications from Esko (ArtPro+ and the legacy editors ArtPro, PackEdge and Plato) can also launch tasks from within that application, then on the file that they currently work on. This is also possible from within Adobe Illustrator when using an Esko DeskPack plug-in.

- **From external systems:**

Automation Engine tasks can also be launched directly by external systems. Automation Engine offers many tools for a two way integration with non-Esko applications such as business systems.



**Important:** Detailed technical requirements for server and client computers are not described in this manual but on <https://www.esko.com/en/systemrequirements>.



**Tip:** Learn more about its architecture in the module one [Esko Blended Learning](#).



## 2.1.2. Data Management and Central Resources

### Data Management and Central Resources

The (prepress) data that Automation Engine can work with does not have to be stored on the Automation Engine server, it can also be stored on a dedicated file server. Automation Engine can work with any data that is stored on network shares that you configured on Automation Engine. These places are called **Containers**.

Automation Engine offers databases to structure, manage and quickly access to files. Learn more in [the Jobs and Products concepts](#). The database server software is automatically installed. You have the option to use a different database server. Learn more in the chapter [Pre-Install IT Requirements](#) on page 1962.

The Automation Engine server also stores its **Central Resources**. These are for example files related to fonts, color management or RIP'ing (curves, screening files).

## 2.1.3. Multi-Site Environments

Automation Engine itself is restricted to work with data within the same LAN.

- **Access Points** enable up and downloading data from (S)FTP or cloud storage sites to your Automation Engine.
- Esko [WebCenter](#), a web platform for packaging project management, and tools based on Esko Cloud can also be used to share data between multiple AE sites.

### Automation Engine's in different Locations that Collaborate by Sharing Jobs

Learn about this setup in the chapter [Sharing to Collaborate with other AE servers](#) on page 1685.

## 2.1.4. On-Premises or SaaS

### Automation Engine On-Premises

The Automation Engine server software is on-premises when it is installed on a computer of your organization, at a location that you chose. This Automation Engine can be used within the LAN it is installed in.

In this manual, except when mentioned otherwise, the Automation Engine server software is assumed to be installed on-premises.

### Automation Engine SaaS

Software as a Service is a software delivery model in which software is centrally hosted at a hosting company that is not a location of the end-user organization, often referred to a 'data center'. Esko decides the hosting company and manages the installation and maintenance of the software.

An Automation Engine SaaS setup is a single-tenant setup. It is dedicated to one Esko customer.

Your organization, based on an annual license subscription, configures and uses the attributed server(s). All access to it from applications within your organization (Pilot, browser client, ArtPro + ,DeskPack, devices) happens via the web in a secure way.

The files and central resources that an Automation Engine SaaS can process also need to be present at the hosting company, in that data center. Data that are no longer active can be off-loaded to reside on Esko Cloud.

Learn more in the chapter [AE SaaS: When your AE is in a Data Center](#) on page 1633.

## 2.1.5. Scalability and Security

### More Functionality

Automation Engine is a very modular product. The sales modules that you purchased or subscribed to decide the licenses on your server. For example, the "**Layout**" module enables the licences for the "**Step & Repeat**" tasks.

Learn more about sales modules from your Esko sales contact.

### More Power and Usage

The more powerful your Automation Engine server computer is, the faster it will process the background tasks and the faster it will react to all kinds of connection requests.



**Important:** Make sure to check the minimal requirements for the AE server and client computers on <http://www.esko.com/systemrequirements>.

- **Processing Channels:** How many tasks your server will process at the same time is also decided by licenses. A sales module so decides whether your server is allowed to process 1, 2, 4, 8 or 16 tasks



at the same time ("concurrent"). 16 is the maximum. It is also possible to reserve some processing channels for specific tasks.

- **Maximum Client Users:** This same sales module also defines how many client applications can be used at the same time (a.k.a. 'concurrent'). For example: a maximum of 20 Pilot users logged in at the same time.



**Note:** Learn more in the chapter [Automation Engine Server Management](#) on page 1997.

### Fail Safety

Automation Engine offers tools to automatically back up your software configuration and databases. Learn more in the chapter [Automation Engine Server Management](#) on page 1997.

### More Power combined with More Fail Safety

You can add Automation Engine **Assistants** to your Automation Engine **Master** Server.

- An Automation Engine **Assistant** is another computer that helps out by also executing tasks (maybe a specific type of tasks).
- An **Assistant** can also be stand-by to become the Master Server when your Master server is down because of a serious problem. There are many scenarios for disaster recovery. These depend on where the file server is and where the database server is.



**Note:** Learn more in the chapter [Pre-Install IT Requirements](#) on page 1962.

## 2.1.6. The Automation Engine Viewer

The Automation Engine **Viewer** is a tool that you start from the Pilot or browser client to view and inspect files.

It offers powerful features to view, measure and compare files, even when they are different file formats or have different sizes. Even staff in your customer service department can use it.

Each file that you open in this **Viewer** is a stream of pixels sent by the Automation Engine server to your local client. These pixels can be created by the server on-the-fly, or they could have been prepared before, also by the server. This is why the use of the Viewer can have a significant impact on the load of your server.

Learn more in the chapter [Quality Control Tools](#).

## 2.1.7. Integration with Other Applications

### External Applications bundled with Automation Engine

Automation Engine also offers licenses for tasks that use these built-in applications:

- The preflight technology from **Enfocus PitStop Server**.

- Several file **Inspection** tasks from **GlobalVision**.

Learn more in [Quality Control tools](#) on page 1077.

### Integrating with other Esko Applications

Automation Engine offers a bi-directional communication with most other Esko applications:

- Esko **Editors** can link with the Automation Engine server. This way, they use the same central resources (color data, fonts etc.) and can also launch tasks on the file that the operator has open in the editor. Learn more in [Launching Tasks from Editors](#) on page 107.
- Esko **RIP** and **Proof** software (Imaging Engine, FlexRip).
- the **Front End** application of an [Esko CDI \(DFS or Grapholas\)](#) or a [Kongsberg table \(iPC\)](#).
- Integration with [Esko WebCenter](#). Learn more in the dedicated chapter [Integrating with WebCenter](#) on page 1741.
- Integration with [Esko Share & Approve](#). Learn more in the dedicated chapter [Integrating with Share & Approve](#) on page 1762.

### Integrating with External Systems

Apart from classic tools like integration via Folder Access Points or exchanging data via FTP, Automation Engine offers a wide range of integration capabilities with external systems. These tools can use XML, JDF or even direct database interaction.

Learn more in the dedicated chapter [Integrating with External Systems](#) on page 1769.

## 2.1.8. Scripting

Although Automation Engine already offers a wide set of tools to create custom workflows, it is still possible that you miss some functionality or maybe to support less standard graphics format that you still use or receive.

This is why Automation Engine also offers custom scripting: you can write scripts (small programs) that typically represent actions that operators do interactively in their graphic desktop applications..

Learn more in [Using Scripts](#) on page 1917.

## 2.1.9. More Help?

Next to this elaborate documentation set, these tools can also help:

- **Tool Tips:** In many places in the Pilot, hover your mouse over a button or text to get a short explanation.
- In each dialog of a task ticket (and some other places), click on  to open the online documentation page for that specific topic.
- **Keyboard Shortcuts:** They are listed in the Pilot's **Help** menu.
- You can still see some old eLearning modules about several basic concepts on the [Esko Blended Learning platform](#).
- The [Esko Knowledge Base](#) contains information that is not part of this documentation. It contains articles about temporary topics, very technical topics, tips and tricks or specific error messages.

## 2.2. File Types and How they are Recognized

### Supported File Types

Automation Engine recognizes most of the standard file formats in the printing and packaging industry (graphics, CAD and communication standards). It also supports Esko native formats like ArtPro (AP) and ArtiosCAD (ARD, MFG).

Most graphics functionality runs on PDF.

- Learn more about benefits of 'normalization' in [Normalized PDF and XMP in Automation Engine](#) on page 44.
- Learn more about native PDF workflows in [PDF+ in Automation Engine](#) on page 52.
- Learn more about the use of PDF/X-4 in the separate document available on the [Automation Engine documentation page](#), in the section "Related documentation".

When your production file format is ArtPro native, you can also choose to execute background tasks on the native AP format by using [ArtPro Action Lists](#).

**Table: File types offered by the Pilot's 'Filter' tool**

File Type	File Extension	Description
A3D	A3D	3D format of Esko ArtiosCAD
Adobe Illustrator 8.0	AI	These old AI files can still be read with the task that normalizes PostScript data.
Adobe Illustrator	AI	Since v9, AI files can be the native AI format, which Automation Engine cannot read/normalize, or they can be saved as PDF compatible. The Pilot checks and shows the real format.
ARD	ARD	Native CAD format of Esko ArtiosCAD (one-up)
ArtPro	AP	Native format of Esko ArtPro
CT	CT	Contone file (Esko legacy picture format)
JS	JS	'Job Sheet' (used in TIFF/IT workflow)
LC	LC	Esko legacy contour (vector)
LP	LP	Esko legacy bitmap
Plato Plate	PLA	Esko Plato layout file, referring to legacy GRS files
BMP	BMP	Bitmap image
CDI	LEN, LENX, VIEW	RIP'ed (view) file for Esko CDI (flexo CTP)
CoreIDRAW	CDR	CoreIDraw native graphics
CFF2	CF2	Packaging CAD format
CSV	CSV	Comma Separated Value, typically exported from a spreadsheet or database
CTD	CTD	Preview data of CT file

File Type	File Extension	Description
Collada	DAE	Format for interactive 3D applications, XML version
DAT	DAT	Archive file of all impositions and page lists of a Job (Esko page workflow)
DCS	EPS, DCS	Desktop Color Separation, a collection of EPS files
Microsoft Word 97- 2003	DOC	Old native MS Word document
Microsoft Word	DOCX	Native MS Word document
DXF	DXF	CAD format
EPS	EPS	Encapsulated PostScript file
Flat	-	Item in Esko page workflow (set of plates)
Adobe FrameMaker	FM	Native file
GRA	GRA	Legacy Esko format (page graphics)
GRC	GRC	Legacy Esko format (label or packaging graphics)
GRI	GRI	Legacy Esko format (imposition output)
GRO	GRO	Legacy Esko format (generic output)
GRQ	GRQ	Legacy Esko format (QuickStep layout)
GRR	GRR	Legacy Esko format (layout)
GRS	GRS	Legacy Esko format (graphics)
GRT	GRT	Legacy Esko format (tiles)
GRV	GRV	Legacy Esko format (view data)
GRZ	GRZ	Legacy Esko format (ZIP'ed)
HTML	HTM, HTML	Web page
Imposition File	IMP	Imposition created by Esko FastImpose
Imposition File (GRS)	IMP	Imposition created by Esko FastImpose, referring to legacy GRS files,
Imposition	-	Item in Esko page workflow
Adobe InDesign	INDD	Native graphics format
JDF	JDF	Job Definition Format ( <a href="http://www.cip4.org">www.cip4.org</a> )
JMF	JMF	Job Messaging Format, HTTP version of JDF
JPEG	JPG	Picture
Layer	-	Item in Esko page workflow (layer of an Imposition)
MFG	MFG	Esko ArtiosCAD manufacturing file (CAD layout)
MJM	MJM	JMF Mime Package
PAF	PAF	Legacy version of Packed Archive Format.

File Type	File Extension	Description
PAF	PAFSC	Packed Archive Format. Esko native format to exchange graphics files.
PAG	PAG	Legacy Esko FastImpose "page" file
Page	-	Item in Pages View (Esko page workflow)
PageSlot	-	Empty item in Pages View (Esko page workflow)
PDF	PDF	Portable Document Format. Including <a href="#">PDF+</a> .
PDF Plato	PDFPLA	Esko Plato layout (PDF with references)
Normalized PDF	PDF	PDF checked by Esko for print-ability, enriched with XMP metadata, allowing external references
PDF Station	PDFSTA	Esko Plato "station" file
PICT	PICT, PCT	Old file format often used for screenshots
PLA	PLA	Legacy Esko FastImpose "plate" file
Adobe PageMaker	PMD	Native file
PNG	PNG	Portable Network Graphic (picture)
PPF	PPF	Print Production Format (CIP3 ink key settings)
PPML	PPML	Personalized Print Markup Language, XML-based standard for Variable Data Printing
PostScript	PS	PostScript file
PSD	PSD	Adobe Photoshop file
Microsoft Publisher	PUB	Native file
QuarkXpress	QXD, QXP	Native file
Rich Text Format	RTF	Text format
RTL	RTL	Old pixel format for HP proofers
RunList	Runlist	List of required page or station files (imposition and layout workflow)
Section	-	Item in Esko page workflow
Sheet	-	Item in Esko page workflow
Sheet Side	-	Item in Esko page workflow
SIG	SIG	Legacy Esko signature file (page workflow)
STA	STA	Legacy Esko Plato "station" file, GRS format
TCP	TCP	Esko legacy Trapping Color Pair
Tiff	TIF, TIFF	Tagged Image File Format
TIFF/IT	TIF, TIFF, LW, CT...	Version of TIFF, bitmap separations

File Type	File Extension	Description
TXT	TXT	Simple text format
U3D	U3D	3D graphics format, supported by Acrobat
VRML	WRL	3D graphics format
Microsoft Excel 97 - 2003	XLS	Older version of spreadsheet file
Microsoft Excel	XLSX	Spreadsheet file
XML	XML	Extensible Markup Language
ZAE	ZAE	Format for interactive 3D applications, full version
ZIP	ZIP	Archive file

### Automatic File Type Determination

Several Views in the Pilot show a column **File Type**. Also in the browser client, file types are recognized. The shown file type determines the functionality that the client application offers on that file.

Several steps are used to determine the correct file type:

1. The client immediately shows the file type based on the file's extension.
2. In the next second, for some files, a second check is done. This can change the shown file type. For example: The file type of a file with an extension `.AI` that was saved as PDF compatible, will so change from "Adobe Illustrator file" to "PDF file".



**Note:** This extra check is not done for all file formats. To manually change the file type, right-click the file and choose **"Change File Type"**. This can for example be necessary to enable launching a specific task on that file.

3. When a task is started, the task does an extra check as well, to make sure it is worth launching that task on this file. This for example also happens when *Access Points* receive files with an extension that you cannot control.

## 2.3. Important Concepts and Work Modes

We here introduce some important terms that we use in the next chapter *Getting Started* on page 76.



**Note:** Although parts of it are outdated, it might still be interesting to check the interactive **eLearning Module** that introduces the Pilot. Find it on the *Esko Blended Learning platform*.

### 2.3.1. Containers (introduction)

A **Container** is a network share that contains data that Automation Engine can work with. Containers can be located on your Automation Engine server or on another computer in the same LAN (Local Area Network).

You can create a Container by using (part of) an existing network share or you can have Automation Engine create the network share while creating a Container. To manage Containers, go to **Tools > Containers**.

The installation of Automation Engine by default creates an "ExampleJobContainer" on the disk drive where you installed the server software.

You can add many more Containers. You can see and browse through them in the Pilots' **Containers** mode. An example:

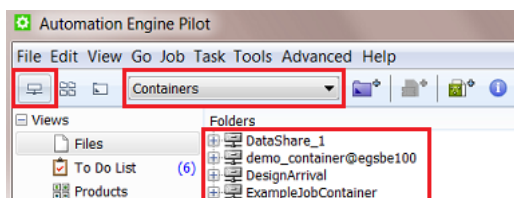

### Looking at Files or Looking at Database Items

As an AE user, you can choose to

- Use the **Files** view, where you see and manage data by browsing through **Containers**. This is a classic way of accessing data, but if you combine it with using SmartNames and **Workflows**, you can also get a high level of automation.
- Use one or multiple Pilot or browser client **Views** that offer faster and smarter ways to access and manage data.
  - **Jobs**: a database representation of "jobs to do". Each Job has it's specific parameters. One of those is the folder containing the data for that specific **Job**. In the Pilot, these **Job Folders** show up as a blue folder.
  - **Products**: a database representation of one-up assets, easily linked to Job where they play a part in. This is typically used at packaging and labels sites that do print re-runs. Using this **Products** tool significantly improves their data management.

Many more Pilot or browser client **Views** focus on a specific type of workflow or output. All these Views are introduced in [Pilot Views and Tools](#) on page 113. Some are described in detail in dedicated chapters.

## 2.3.2. Jobs (introduction)

### What is a Job?

In Automation Engine, a **Job** represents work that has to be done. A Job contains all the files and information related to a specific job-order. A Job has a unique name. Depending on your type of business, your Job could be to create a specific asset or to physically produce something, or a combination of both.

A Job represents a job-order and is therefore also "WIP": Work In Progress. This also means that, in Automation Engine, you should remove Jobs that are finished. The Jobs database can hold a few thousand Jobs, but having that many Jobs means that there is something wrong with how you use this tool.

A Job is an item in the Automation Engine Jobs database, its **Job folder** is displayed as a blue folder icon.

In the **Containers** mode and **Files** view, you can see the location of Jobs in their Container:

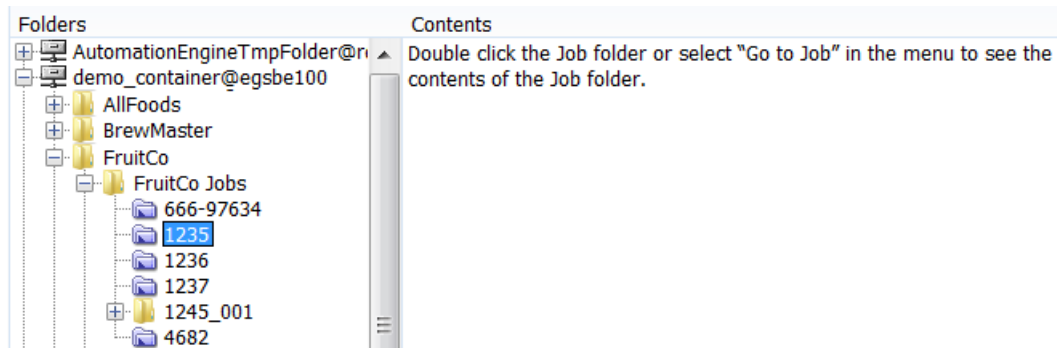

Once a Job is open ("**Last used Job** mode"), you can see its subfolders and files.

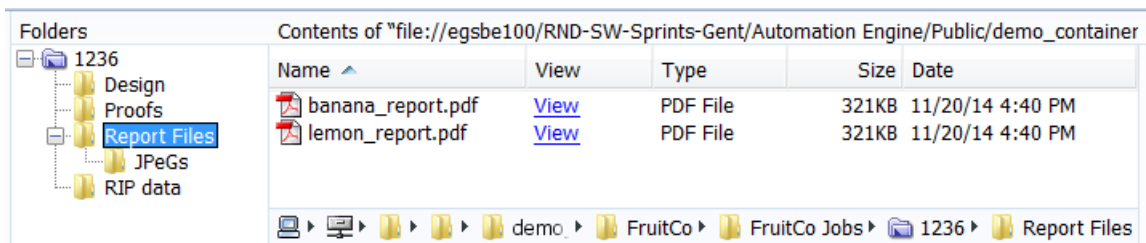

### Job Metadata (Job Setup Parameters)

A Job can have an extended set of metadata: inks, barcodes or layouts to use, customer information, categorizations or any other custom parameter. This metadata is also stored in the Jobs database, and can be used when launching tasks on files that are present in the Job folder of Job.

Ideally, these **Job Setup** parameters are not set manually but came in automatically when the Job was created by your business system.

### Job based Automation

Automation Engine is very Job-centric. Workflow tasks can take their settings from the **Job Setup**. They can even be launched automatically when the Job reaches a certain status (for example: all the expected files have been delivered, the **Milestone** changed to 'Approved' etc...).



**Note:** When you choose not to work with the Jobs tool, you can still get a similar level of automation by using alternative tools like [Workflow Parameters](#).

### Job Folders

Each Job has a Job Folder. Job Folders are located somewhere in a Container and typically have a similar substructure, for example specific subfolders for artwork, production file(s), proof or other output file(s).



Learn more in the dedicated chapter [Jobs](#) on page 538.

### 2.3.3. Products (introduction)

A **Product** represents a production asset. The Products database stores their location within the Container plus a lot more metadata, for example their status, their graphics parts, etc.

The **Products** view is a user friendly, searchable view on the Products database. You can use it to create new Products, search them and link them to Jobs.

Customers doing a lot of print re-runs use the Products tool to easily re-link production files that they printed earlier to the new Job (the one representing the order where the product was re-ordered).

Learn more in the dedicated chapter [Products](#) on page 594.

### 2.3.4. Page Workflow Views and Tools (introduction)

Customers with page (imposition) workflows typically combine the Jobs tool with the 3 Views in the category "**Commercial Print**":

- The **Pages** view allows to build page lists, monitor incoming pages and their individual state of approval.
- The **Proofs** view shows the proof data that was made of the imposition and its status.
- The **Plates** view shows the status of the expected plates for that Job.

Impositions can be created with legacy editor Esko FastImpose or with non-Esko applications.

Automation Engine is fully equipped to serve high automated JDF workflows.

Learn more in the dedicated document on "Commercial Print (Imposition) workflows in Automation Engine". Find it next to the "Complete Manual" of version AE **18.1** on <https://www.esko.com/en/Support/Product?id=Automation%20Engine&ver=18.1>.

## 3. PDF Formats and Metadata

---

### 3.1. Normalized PDF and XMP in Automation Engine

---

#### 3.1.1. Introduction

##### Naming Convention

In this section, PDF files that have not gone through normalization will be referred to as “**PDF**”. PDF files that have been normalized will be referred to as “**Normalized PDF**”.

##### Normalization in Automation Engine, your choice...

- **In Automation Engine 16 till 18.1 - Before PDF+**

There are 2 types of technologies handling graphic files:

- **PDF tasks:** These tasks process PDFs without prior normalization.
- **Normalized PDF tasks:** These tasks require a PDF to be normalized before they process it.

These 2 types of tasks can be mixed in a workflow:

- PDF tasks can process Normalized PDFs.
- Normalized PDF tasks will automatically normalize regular PDFs.

- **Since Automation Engine 18.1.1 - Since PDF+**

Automation Engine 18.1.1 (Nov 2019) introduced the first tasks handling PDF+ files from ArtPro+. This added a 3rd type of PDF task technology, but it is the one that eventually will replace Esko's PDF Normalization.

Learn all about PDF+ and this native PDF workflow in [PDF+ in Automation Engine](#) on page 52.

#### 3.1.2. What Makes a Normalized PDF Special?

##### Overview

Normalized PDF files are to a large extent regular PDF 1.6 files, except in these specific areas:

- External references
- Color space
- Document level metadata
- Object level metadata

### External references

A Normalized PDF is not always self-contained. It can refer to images or other PDFs that are not embedded in the PDF itself. Making use of references instead of embedding images and/or graphics can have several advantages in the workflow.

- The main advantage is that it allows for “**late binding**”.

For example: An image can be color corrected. After the color correction all PDFs that refer to this image will automatically contain the corrected version of the image without the need to open and rewrite these PDFs.

- Working with Normalized PDFs that have external references can also lead to **faster processing**, especially when the Normalized PDF refers to large amounts of external image data.



**Attention:** Although referring to external files is a standard PDF feature (for example used in the PDF/X-5), most PDF applications do not support this. To guarantee that a PDF can be processed correctly by a PDF application (like Adobe Acrobat), it has to be made self-contained (embedding all the referred components like images). A self-contained Normalized PDF is 100% PDF compatible.

### Color space

A Normalized PDF can only contain objects in the final printing color space. This final printing color space can have any number of separations but in most cases this will be CMYK and some spot colors. The PDF object model allows objects to be defined in RGB and CIE based color spaces. This is not possible in Normalized PDF. During normalization such objects are color converted to CMYK.

The fact that Normalized PDF cannot contain objects in RGB or CIE based color spaces is its biggest limitation. On the positive side, it makes the workflow more predictable. It avoids late and often somewhat hidden color conversions (for example in the RIP) that can lead to problems in printing.

### Document level metadata

A Normalized PDF contains XMP metadata. The schema of the XMP data is Esko specific, but the specification is public. The XMP metadata serves 2 purposes. It contains info about the file that can be extracted by 3th party applications and used for example for quality control or asset management. The XMP metadata are also used by Esko applications like Automation Engine to retrieve information from a PDF in an efficient way (for example the number of separations).

### Object level metadata

A Normalized PDF contains metadata for specific objects like barcodes. Object level metadata are added to allow modification of those objects using an Esko application. Object level metadata are stored using a proprietary mechanism and format.

## 3.1.3. Which Tasks Require PDF Normalization?

The Esko normalization technology is related to a graphics software kernel from Esko named '**Brix**'. This is the kernel that is also used in products like PackEdge and Plato.

Historically, 2 other graphics kernels entered Esko's product offering: the one using the **ArtPro** native file format and the **Enfocus** PDF library.

The [second part of this chapter](#) explains the most recent graphics kernel: the PDF+ native one as used in **ArtPro+**. Eventually, this one is to replace the 3 mentioned above, which is why we also name those 3 the 'classic' ones.

This sections contains [a page that lists all task types and the graphics technology they use](#). This includes all task types that rely on Normalization. i.e. that use the Brix technology.



**Note:** Mind that the types of tasks available on your Automation Engine server depends on the licenses you have ; so some tasks in the list below may not be visible in your client application.

### 3.1.4. How do PDF native tasks Work with Normalized PDF Files?



**Important:** The PDF tasks require self-contained input files and will therefore automatically embed all external references that a Normalized PDF file may have.

An example:

Below example workflow takes a file, removes the separation named "Cut" and then traps the file. This workflow can be used with both Normalized and native PDF documents.

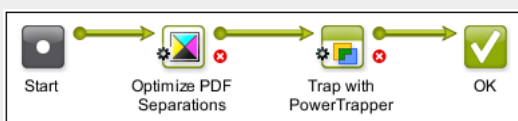

We here describe how Automation Engine processes a Normalized PDF input file in this workflow:

Task	Task Type	Description
Optimize PDF Separations (Classic)	PDF task (Enfocus PDF technology)	<p>The task checks whether the Normalized PDF input file contains any external references to images or other Normalized PDFs:</p> <ul style="list-style-type: none"> <li>If there are <b>external references</b>, the "Optimize PDF Separations" task will first make the Normalized PDF input file <b>self-contained</b> (by embedding all the external references).</li> <li>If there are <b>no external references</b>, the task will process the Normalized PDF directly.</li> </ul> <p>The task also updates the XMP document metadata.</p>
Trap with PowerTrapper (Classic)	Esko Normalized PDF task	The task traps the Normalized PDF file.

### 3.1.5. How do Normalized PDF Tasks handle native PDF Files?

We again use this example workflow:



Task	Task Type	Description
Optimize PDF Separations	PDF task	The PDF is processed directly, there is no normalization done.
Trap with PowerTrapper (Classic)	Normalized PDF task	The task detects that the input file is a regular PDF file, and first automatically normalizes it. Then, this normalized PDF is trapped and the output is a <b>self-contained Normalized PDF</b> .

The task ticket that is used for this **Automatic Normalization** can be selected in the **Configure** tool (Pilot: **Tools > Configure > Processing Preferences > Automatic Normalization**).

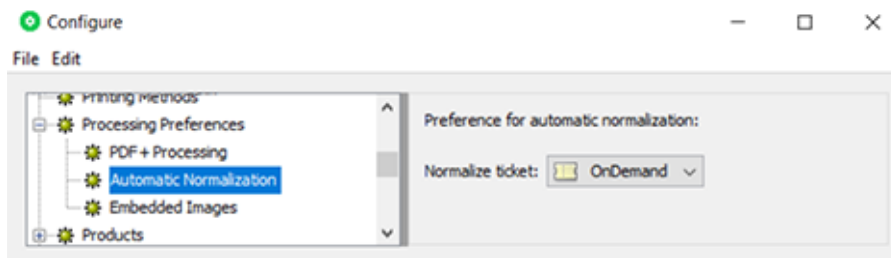

By default, Automation Engine uses the ticket named **“OnDemand”**, a ticket of the [Normalize PostScript / PDF / Illustrator 8.0 File \(Classic\)](#) on page 385 task.



**Attention:** From this ticket, only the settings in its tab **Color Management** are taken into account. All other settings of this automatic normalization are forced to fixed default settings. For example, automatic normalization will always embed all images.

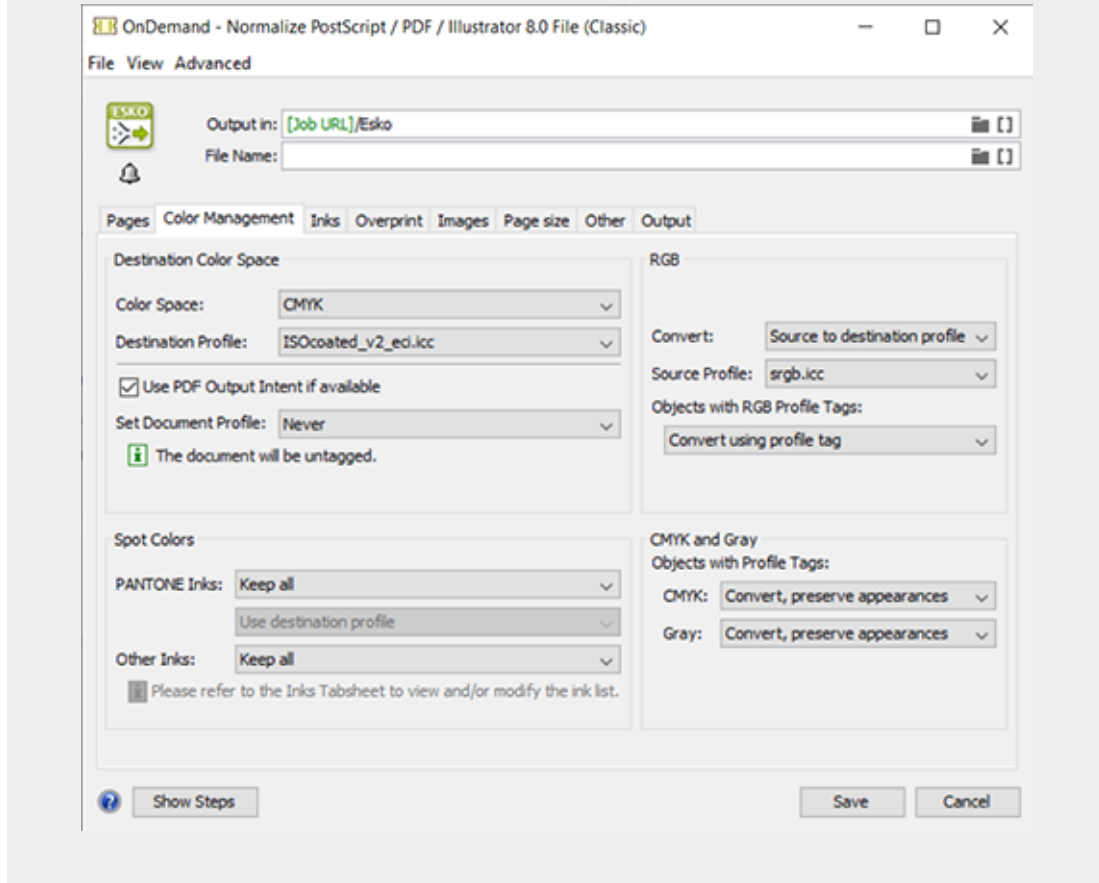

### 3.1.6. PDF Normalization and Step & Repeat



**Attention:** This page is not about the Step & Repeat tasks that use the ArtPro+ PDF+ graphics kernel. It only describes that the 'Classic' S&R tasks can also handle PDF native files but that this may include background normalization.

The Step & Repeat (**Classic**) tasks support both regular PDF and Normalized PDF as input files, or even a mix of both.

The format of the task output file depends on your choice in the ticket.

#### Output Formats

Depending on your choice in the step & repeat ticket's setting **Output Format**, the format of the output file can be:

- a PDFPLA
- a self-contained Normalized PDF
- a native PDF

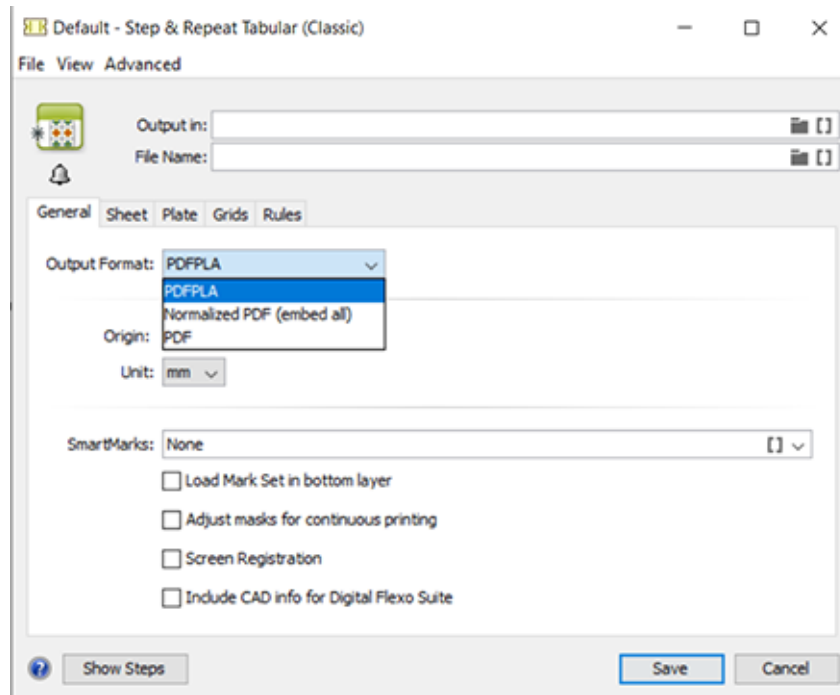

### Output format PDFPLA

A PDFPLA is a Normalized PDF with external references to the one-ups, which also have to be Normalized PDFs.

A PDFPLA file can be edited and modified in Esko Plato. It can be RIP'ed directly by Esko Imaging Engine and FlexRip. To send it to a non-Esko system, first export the PDFPLA to a (self-contained) PDF using the [Export to PDF File \(Classic\)](#) task.



**Note:** PDFPLA output can only be generated when all input files are Normalized PDFs, else the task will fail.

PDFPLA is the **recommended output format** when the primary purpose of the step & repeat file is to **send it to Imaging Engine or FlexRip**.

### Output format Normalized PDF (embed all)

In this case, the task output file is a self-contained Normalized PDF. The one-ups are embedded in the PDF. The PDF technique 'PDF forms' is used so that the file size remains compact.

This file can not be modified in Esko Plato. It can be RIP'ed directly by an Imaging Engine or FlexRip. It can also be sent to a non-Esko system.

Normalized PDF inputs will be embedded in the output. PDF inputs will first be automatically normalized and then embedded in the output.

This format is **recommended when further processing is needed on the output**, for example by the task [Optimize PDF Separations \(classic\)](#) before sending it to Imaging Engine or FlexRip.



### Output format PDF

When you choose this option, the output of the step & repeat task is a PDF. The one-ups are embedded in the PDF. The PDF technique 'PDF forms' is used so that the file size remains compact.

This file can not be modified in Esko Plato. Imaging Engine or FlexRip can not RIP this file directly ; they will first automatically normalize this step & repeat PDF file. This file can be sent to a non-Esko system.

Normalized PDF input files will be embedded in the output. PDF input files will be embedded in the PDF 'as is'.

This format is **recommended when the primary purpose** of the step & repeat file is to send it to a **third-party, a non-Esko RIP**.

### 3.1.7. Normalized PDF XMP Metadata (the File's Info Dialog)

XMP stands for 'eXtensible Metadata Platform', a *standard* defined by Adobe. XMP is a technology that allows embedding data *about* a file, known as metadata, *into* the file itself, in the format of XML.

Adobe uses XMP in its own applications like the **Creative Cloud** applications (Acrobat, Illustrator, InDesign, Photoshop, ...) and has defined a number of XML schema. The XMP framework was designed to be extensible so that other vendors like Esko can define additional schema and add their XMP metadata to the file as well.

When Esko applications "*normalize*" data, they also add XMP to the resulting PDF file. Files created by an Esko RIP also contain XMP.

An example: In the Pilot or browser client, the **Info** dialog shows you the XMP of the selected file (here a Normalized PDF):

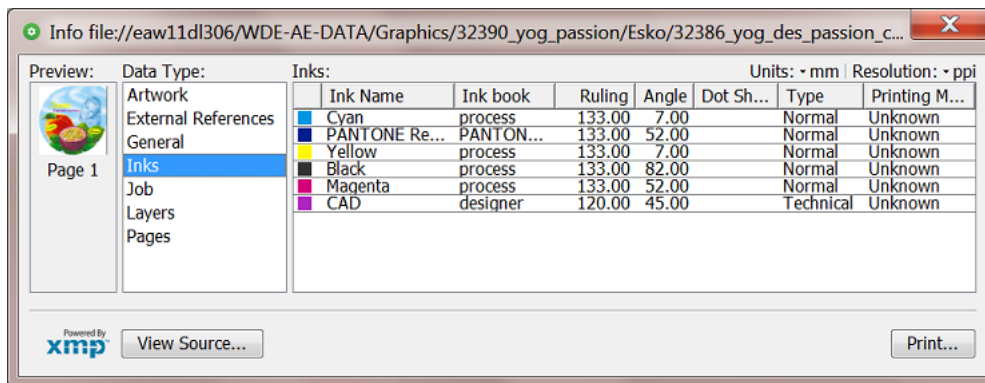

The XMP of a Step & Repeat file also shows basic info on its grids:

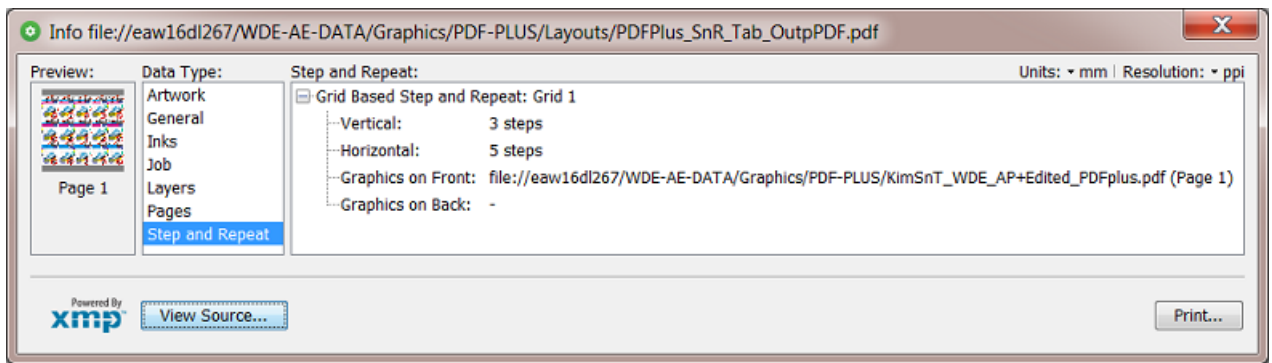

**Note:** There are also Esko tools that generate regular native PDF files but still include the Esko XMP section:

- PDF files generated by the DeskPack Data Exchange plug-in
- PDF files generated by the Dynamic VDP tasks (i.e. not the 'classic' ones).

Some advantages of XMP:

- By only reading the XMP, you can learn a lot about the file without really opening the file.
- Quality control tools can read the metadata and compare specifications against actual values.
- Asset management applications can read the metadata and use this information to catalogue digital files for fast search and retrieval.



**Attention:** There is no mechanism to detect modifications done in the PDF by non-Esko applications! When an external application edits the PDF (for example remove an ink), the file's Info dialog will still use the metadata from the XMP: i.e. the Esko XMP metadata is not invalidated.



**Attention:** "PDF proxy" files are PDF files generated from an Esko Normalized PDF, for example for proofing or for remote exposure. The XMP data embedded in a PDF proxy is still the metadata of the Esko Normalized file from which that PDF proxy was derived.

Find the XMP specification in the separate document "XMP Metadata in Graphics Documents". Find this PDF [next to the Automation Engine documentation](#), as part of the "**Related Documentation**". You will there also find the documents on XMP in RIP output ("XMP metadata in Digital Film Sets").

## 3.2. PDF+ in Automation Engine

---

### 3.2.1. PDF+, Successor of Normalized PDF

#### What is PDF+ ?

- PDF+ is the next generation internal graphics format in Esko applications.
- PDF+ is native PDF.
- The '+' in the name PDF+ means 'additional information'. It does not refer to a conversion.
- An important item in this additional information are the **Processing Steps** and content' ([ISO 19593](#)).



**Note:** ISO 19593 defines a new mechanism to store objects and metadata corresponding to finishing production steps in a PDF file in a standardized way. Based on this ISO standard, the use of Processing Steps was introduced in ArtPro+ as **Processing Step Layers**.

Giving layers the attribute of a type of processing step (for example the type 'embossing') enables to no longer use the attributes 'technical' and 'varnish' that you could set for 'Inks'. Those extra ink-type attributes are Esko proprietary attributes restricted to use in normalized PDF. PDF+ enables to skip using those and instead use this ISO conform way to use layers for this purpose.

- PDF+ is based on ISO 32000-1:2008, corresponding to the Adobe PDF 1.7 specification. Find an ISO approved version of the specification on [here](#).
- Currently, PDF+ is the format used in and written by Esko ArtPro+ and several AE tasks.



**Note:** [This KB article](#) also explains PDF+ from a more generic standpoint.

### Why is PDF+ replacing Normalized PDF?

These are the 2 main reasons why PDF+ replaces Normalized PDF:

- The PDF format itself became more print-aware.
- The interoperability requirements became broader.

Some more specific advantages to have your Esko workflow use PDF+ :

- Any flavor of PDF is supported throughout the system (editor, workflow system, RIP).
- Editors and workflow server make no unnecessary changes to the PDF files.
  - They preserve 3rd party metadata.
  - They don't change the structure of the PDF file.
  - They only make the changes that the user requests.
- PDF (+) allows for object based screening. Normalized PDF only worked with screening per ink.

### Limitations of Normalized PDF

Normalized PDF has advantages, but also these limitations:

- Technical:
  - A Normalized PDF is 'fixed' to the capabilities of its 'BRIX' kernel. For example: in a multi-page PDF, mixed page sizes were never supported.
  - A Normalized PDF always has its focus on print output (converting all RGB, ...). Today's needs are broader.
  - In the meantime several industry standards have emerged that serve the concept of normalization (PDF/X, ...). And some of the semantics in Esko's Normalized PDF became outdated by ISO specifications (ink order, processing steps, ...).
- Interoperability
  - The normalization process removes all 3rd party metadata.
  - Normalized PDF files were not designed to be modified by 3rd party tools. This means that the metadata can easily get out of sync.

**Table: Small Overview of Esko's Graphical Formats and their Technology**

<b>Technology</b>	BRIX	ArtPro	Enfocus PDF library	NDL (*)
-------------------	------	--------	---------------------	---------

<b>File Format</b>	Normalized PDF, PDFPLA, PDFSTA	ArtPro (.ap)	PDF	PDF+
<b>Native Application</b>	PackEdge, Plato, i-Cut Layout, various AE tasks. FlexRip kernel (read only)	ArtPro	PitStop tasks	ArtPro+



**Note:** (\*) 'NDL' stands for 'New Document Layer', an Esko R&D project name.

Find a much more detailed list of technologies in [Which AE task Uses which Technology?](#) on page 66.

### FAQs

- **Q: In a native PDF workflow with PDF+ files, is there still a concept to "normalize" these PDFs?**
  - The concept to 'check and control' PDFs that enter your production flow is indeed still possible. In a native PDF workflow, we recommend Enfocus PitStop to do this. A typical example would be to use preflight tools to avoid RGB data in the production PDF.
  - The main difference with actual normalization to a different 'normalized PDF', is that the Enfocus tools give you full control over when and how this 'check' is done. Plus, your workflow is executed on the PDF that came in, not on a normalized variant PDF file. Automation Engine offers this technology through the [Preflight with PitStop Task](#).
  - Another way to control PDFs that enter the workflow is to use the task [Apply PDF Action List](#). This task allows to automate a linear series of functions that you would otherwise execute within ArtPro+.
- **Q: Can ArtPro+ work with Normalized PDFs?**
  - Sure. When, in ArtPro+, you open and edit a normalized PDF, it will by default save it again as a normalized PDF.
  - But you can as well choose to 'Convert To PDF+' and then save it as a PDF+ file.
  - Learn more in the user guide of [ArtPro+ \(Working with Files > PDF, PDF+ and Normalized PDF\)](#).
- **Q: When you Step & Repeat PDF+ files, what is the output format?**
  - When you step & repeat PDF+ files in ArtPro+, the result is also saved as a PDF+ file.
  - When you step & repeat PDF+ files via tasks in Automation Engine, it depends if the task supports PDF+ files.
    - When the task supports PDF+, the output will be a PDF+ file. This is for example the case for the S&R tasks that are not labeled 'Classic' (which, before AE 22, were named 'Dynamic').
    - When the task does not support PDF+ (i.e. it is labeled 'Classic', because it uses the BRIX technology), then the PDF+ will first be normalized and the output will be a Normalized PDF or a PDFPLA file (depending on the output choice in the ticket).



**Note:** PDFPLA files can only be made when it's one-ups are normalized PDFs.



**Note:** Learn more about which AE tasks support the PDF+ technology in [Which AE task Uses which Technology?](#) on page 66.

- **Q: In a PDF+ file, Images and Placed Art can be 'Linked & Embedded'. Which data is used when?**

- PDF+ is always self-contained ; images and placed art are always embedded. The actual image or art information is saved in the file, at its full resolution. The PDF+ file also keeps a time-stamp of when this data was embedded.
- Optionally, they can also be linked. This means that a reference to the external file is saved in the PDF+ file. These links are not just to images or placed art but can also be to structural design files.



**Note:** In a normalized PDF file, you have to choose between embedding the data or only adding a link. You can not do both.

Learn more on how to create and manage such links in the user guide of [ArtPro+](#).

- AE tasks always use the embedded data. Also a Step & Repeat task by default uses the embedded data.
- An operator of AP+ or an AE task can choose to update that link. The task '[Apply PDF Action List](#)' can 'Update linked images', 'Update linked placed art' and 'Update structural design file'.



**Note:** Normalized PDF could contain an external reference in which case only a low res proxy was embedded in the PDF. As a result, the external referenced files had to be found and used to make final output.

### 3.2.2. Metadata in PDF+ (vs. XMP in Normalized PDF)

#### Why and How To Extract or read a PDF file's Metadata?

There are 2 main reasons why Esko workflows extract metadata out of their production PDFs:

- **To send this information to external systems.** Those systems interpret the XML and show these PDF attributes to their users.
  - **Normalized PDF** file: Use the task [Create PAF / JPG / XML \(LinkEdge\)\(Classic\)](#) on page 277. It was designed to export the XMP metadata that is on board a normalized PDF to an XML file.
  - **PDF(+)** file: Since v20, use the task [Export PDF Info](#) to export the metadata of a PDF+ to an XML file (and it can also create a preview image).



**Note:** This type of XML is aware of 'processing steps' , a typical attribute of PDF+ files.



**Note:** The task [Create Report \(ReportMaker\)\(Classic\)](#) is an exception: Although it is based on BRIX technology used for normalized PDF, it can still read the metadata of a PDF+ file. That is why it can extract info from PDF+ files (inks, barcodes, external references, etc.) and it can also generate 3D previews (when the PDF+ file contains a CAD reference with 3D info).

- **To use this information to increase workflow automation.** Many users create SmartNames that extract metadata and then use it to increase the automation in a workflow.
  - SmartNames that extract XMP from normalized PDF files: [SmartNames that extracted a part of that XMP.](#)
  - There are no SmartNames that can extract metadata from PDF+ files. You can however use Xpath SmartNames on the exported XML file of its metadata.

**In Normalized PDF, Metadata is proprietary and in XMP format**

The *XMP metadata in Normalized PDF* is Esko specific. Additional and Esko specific information is stored in the open source XMP (extension schema). It's purpose is to make the PDF smarter for its packaging workflow.

The XMP data is added during Esko normalization and updated during Esko editing. It is visible in the Pilot, in the file's Info panel.

**With PDF+, do we still Need to Add Metadata?**

PDF+ uses standard PDF as much as possible. All the information that can be stored in the PDF structure (within the boundaries of the PDF imaging model), will be stored in that way. For example 'Ink Order', 'Processing steps', etc.



**Note:** An illustration of this is that when, in ArtPro+, you convert a Normalized PDF to a PDF+, all its Esko proprietary XMP metadata is removed.

Not even PDF 2.0 will support all the concepts and terminology in packaging production. So until that will be the case, Esko will still add what is missing. As before, the reason is to enrich the file's information and enhance the workflow automation.

Only the information for which there is no support (yet) in standard PDF is defined in an Esko proprietary metadata scheme on board that PDF. This complimentary information is why this PDF is named PDF+ .



**Important:** The metadata that Esko adds to a PDF+ is not XMP or XML, it is part of the PDF data stream itself.



**Note:** The PDF+ specification adds metadata to any ISO 32000-1 compatible PDF file. Some of this metadata is purely additional ; there is no corresponding graphical representation in the PDF file, for example the position of the cross-hair. Other metadata describes how the actual graphical representation was generated, for example barcodes.

**Overview of Metadata in PDF+ files**

- Ink order
- Non-printing data (Cut, Die, ...) and special processing steps (varnish, ...)
- Ink Types
- Document Profile, as output intent
- Screening
- Crosshair position
- Group and Barcode metadata
- Marks
- Images
- Placed Art (PDF)
- Structural Design
- Preflight

The technical specification of this metadata, is described in the pages about the task that creates it: [Export PDF Info](#) on page 315.



**Note:** Learn more in the [ArtPro+ user guide](#) (> Working with Files > PDF, PDF+ and Normalized PDF).

**In PDF+, what happens to XMP metadata from 3rd parties?**

With PDF+ (and also Normalized PDF), any **3rd party metadata is removed**. However, any 3rd party (non-Esko) **XMP (metadata) is kept** during the workflow, untouched.

**3.2.3. PDF+ File's Info Dialog**

**The File Info dialog shows the PDF's metadata**

When a PDF+ file is selected, the file Info dialog reads the metadata that Esko added to the PDF. Notice that, as this metadata is not XMP, that there is also no logo of the 'XMP technology' in the below left corner of this dialog.



**Note:** Notice these main differences with the info dialog of a Normalized PDF (which is based on XMP):

- The data type 'Inks' is here split over **Separations** and **Screen sets**.
- The data type 'External References' is here listed as **Placed Art / Images**.

**PDF+ Info Dialog - Examples per Data Type**

A **Data Type** is only listed when such data is present in the file. For example the types 'Fonts' or 'Structural Designs' can be missing.

- **Artwork:**

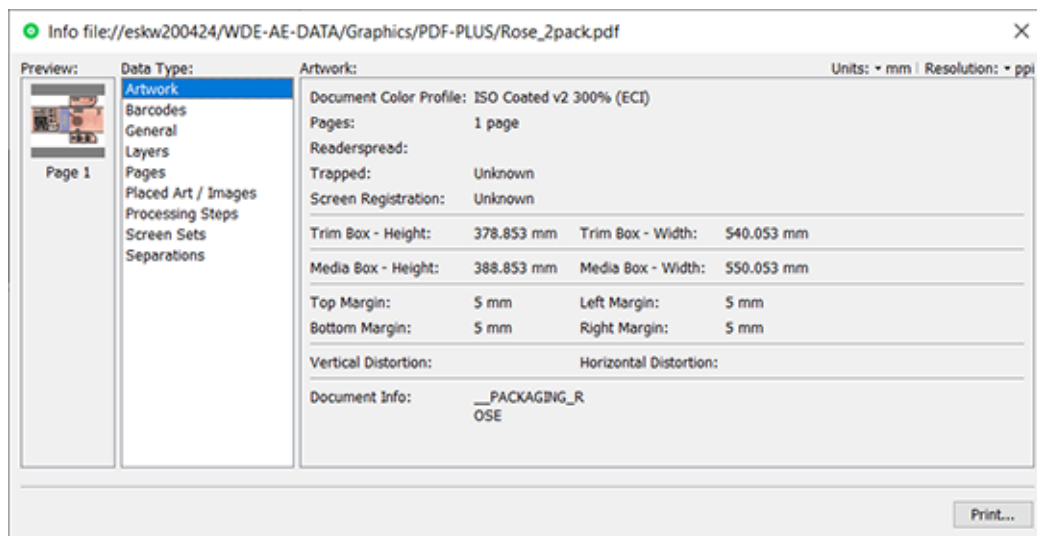



**Note:** The value of the field **'Trapped'** is based on a check if this flag is present in the PDF description ; it does not check the presence of a trapping layer or trapping objects.

• **Barcodes:**

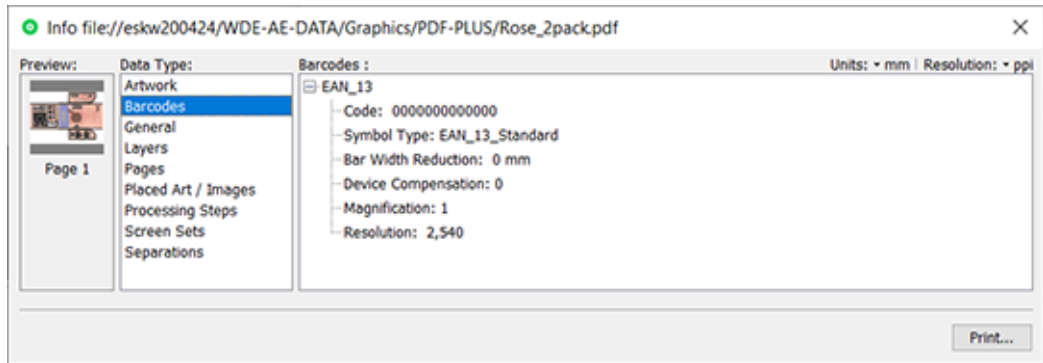

When the PDF contains barcodes that were created with Esko tools, their parameters will appear here. Binary and quaternary barcodes will, next to their own value, also show their decimal representation.

• **Fonts:**

The name and type of the fonts in this document.

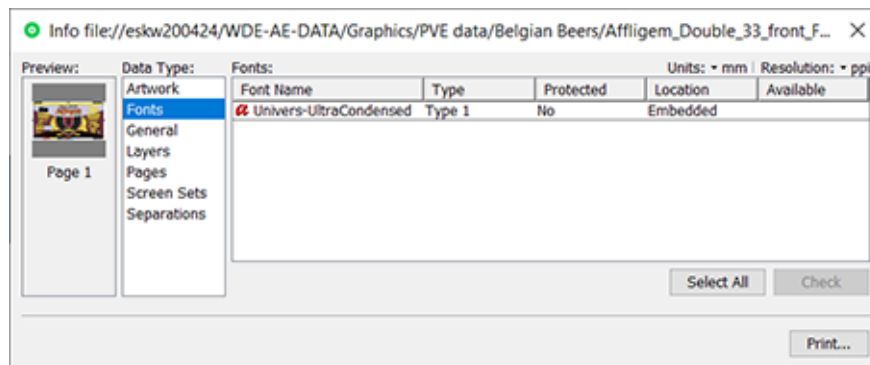

The column **Location** indicates whether the font is

- **embedded** (PDF+ can only have embedded fonts)
- **embedded subset**
- **not embedded**

When no fonts are present in the file, this data type is not shown.

• **General:**



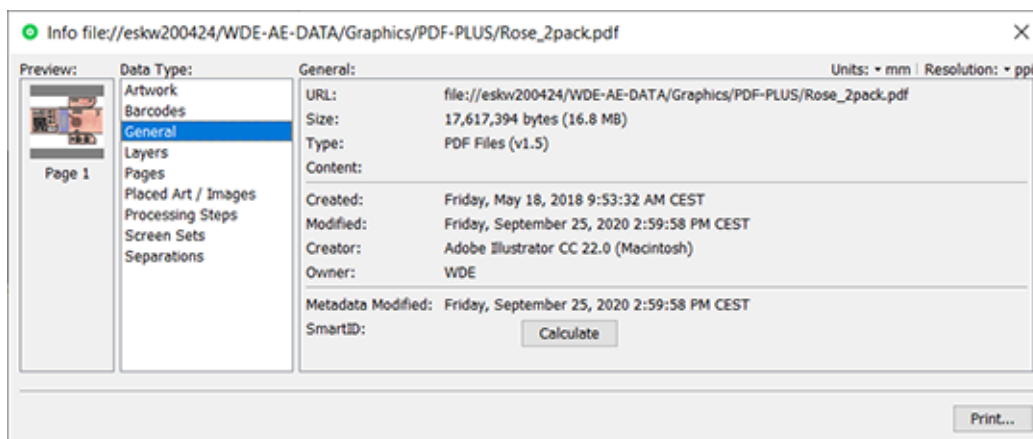

**SmartID:** Click **Calculate** to have the system calculate an identification number for that version of this file. This number is calculated from the combination of an identifier of the document itself and of the identifiers of all its external references.



**Note:** This is not a unique ID, its use case is this: You can for example use its *SmartName* to place this 'SmartID' on the proof (file). When the customer approves what he sees on the proof, he then actually approves that ID. That ID is then also a number that you can make appear on the plate or print, so proving that the file that was considered 'good for print' has not changed in the meantime.

**Esko Cloud link:** When such a link is present in a PDF's metadata, it will here be offered as a hyperlink named **"View on Esko Cloud"**. Learn more about this link in *Task 'Upload Files to Share & Approve'* on page 1762.

- **Layers:**

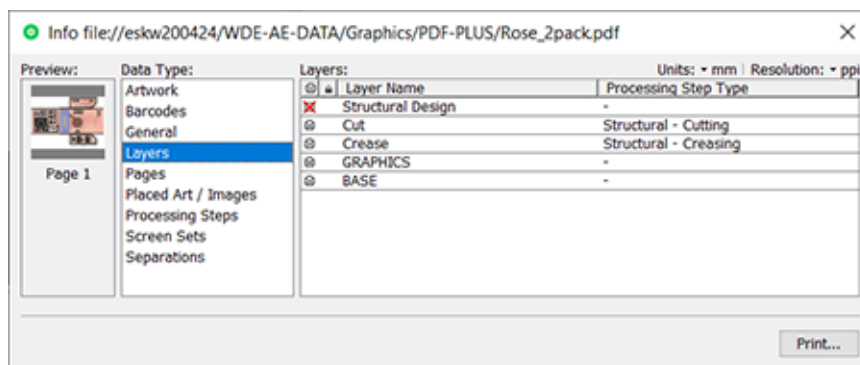

In PDF+, a layer can also be of the type **Processing Step**.

Learn about all them in *Processing Steps - Groups and Types* on page 64.

- **Pages:**

Shows each page's page number and its inks (separations).

- **Placed Art / Images:**

Placed Art or Images are always embedded in the PDF. If there is **also** a link to their original data present in this PDF, they appear in this list:

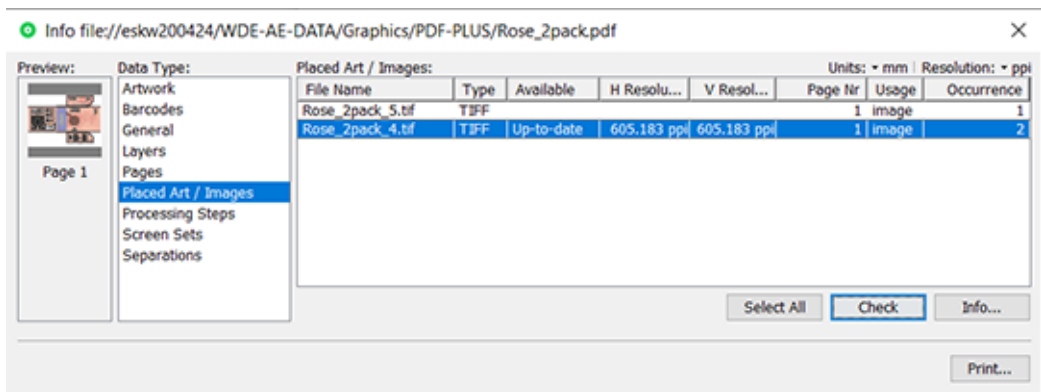

Click **Check** to check the selected link, i.e. the availability of the selected file(s). The result can show that the embedded data of that link are **Up-to-date**, **Not Up-to-date** or **No** (not available).

Click **Info...** to open an extra the info dialog of the selected placed art or image(s).

- **Processing Steps:**

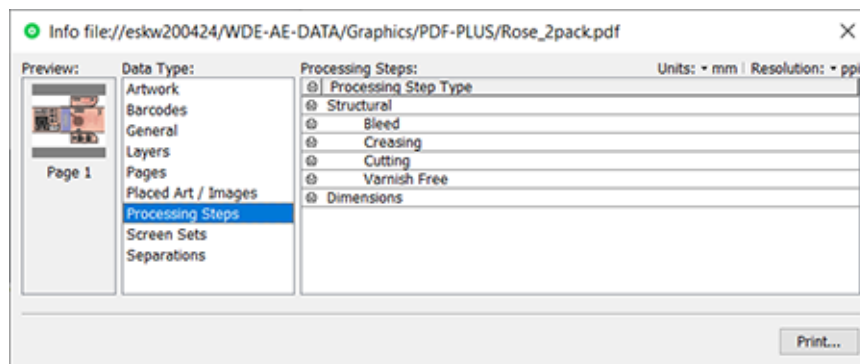



**Note:** Processing steps can also be present in the file as layers. But this is not always the case. For example: A Step & Repeat PDF file can have no special layers but still show the processing steps that are present in its placed art (in the one-ups).

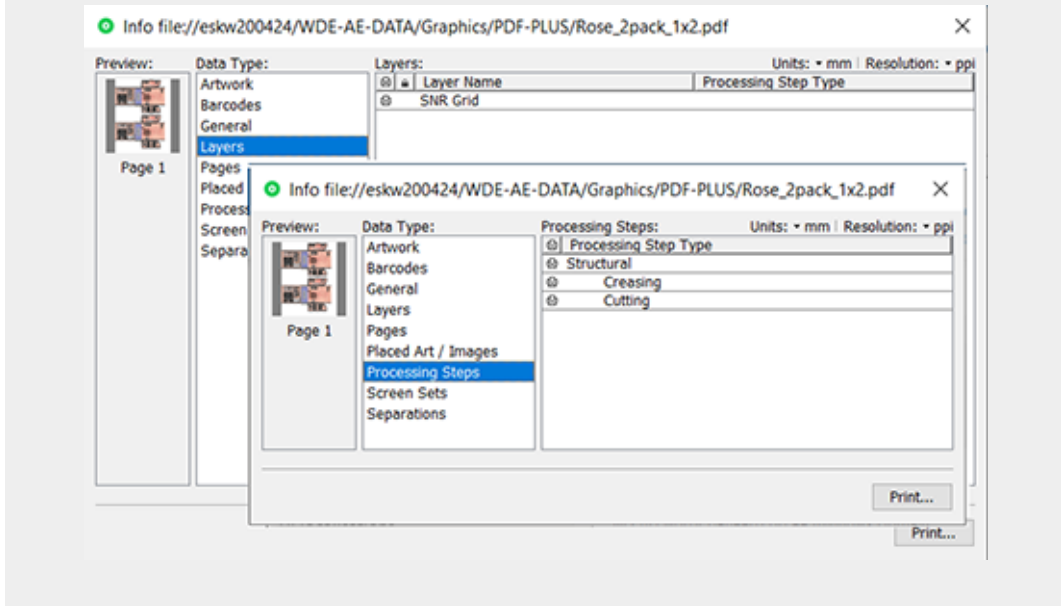

Learn more about this data type below in [Processing Steps - Groups and Types](#) on page 64.

- **Screen Sets:**



**Note:** PDF (+) works with object based screening: Objects are attributed a 'screen set'. Normalized PDF only offered screening per ink.

This example has 3 different sets of screens: one at ruling 120 LPI, one at ruling 250 LPI using the dot CS9 and one at 120 LPI using the dot CS4.

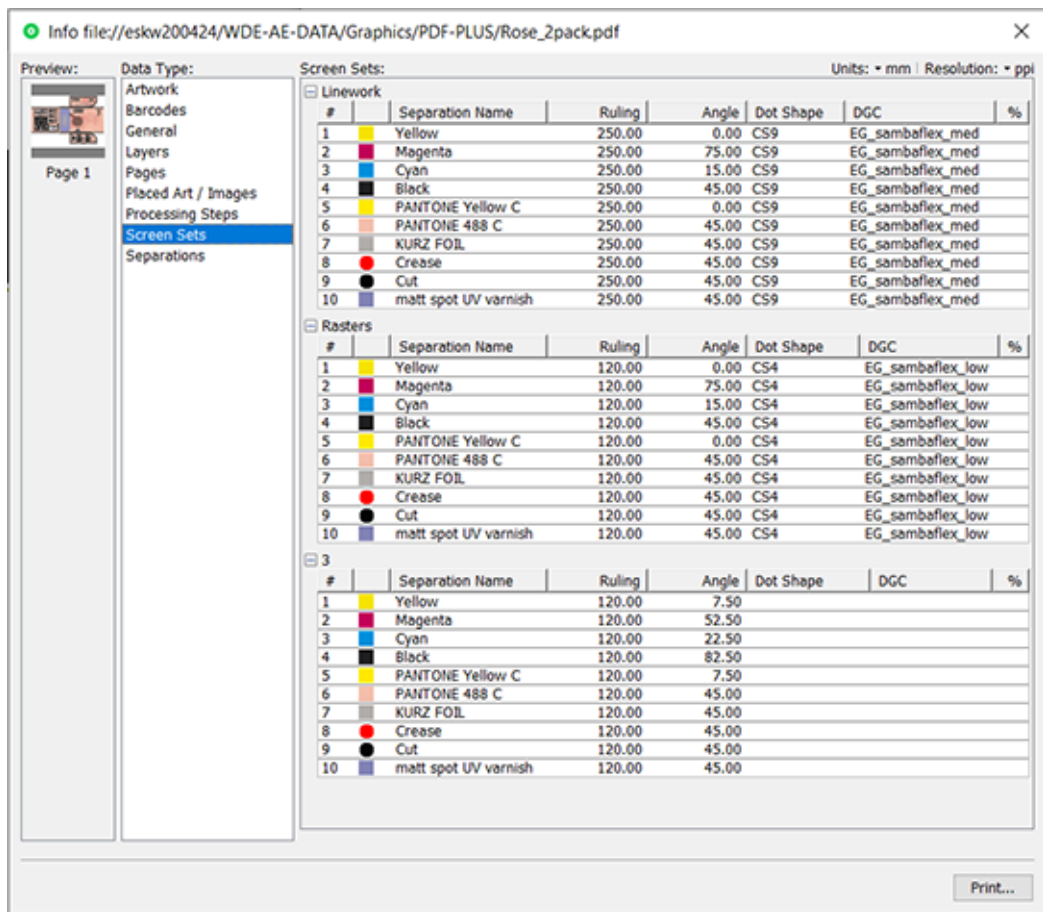

Here's an example of the screening info in RIP data:

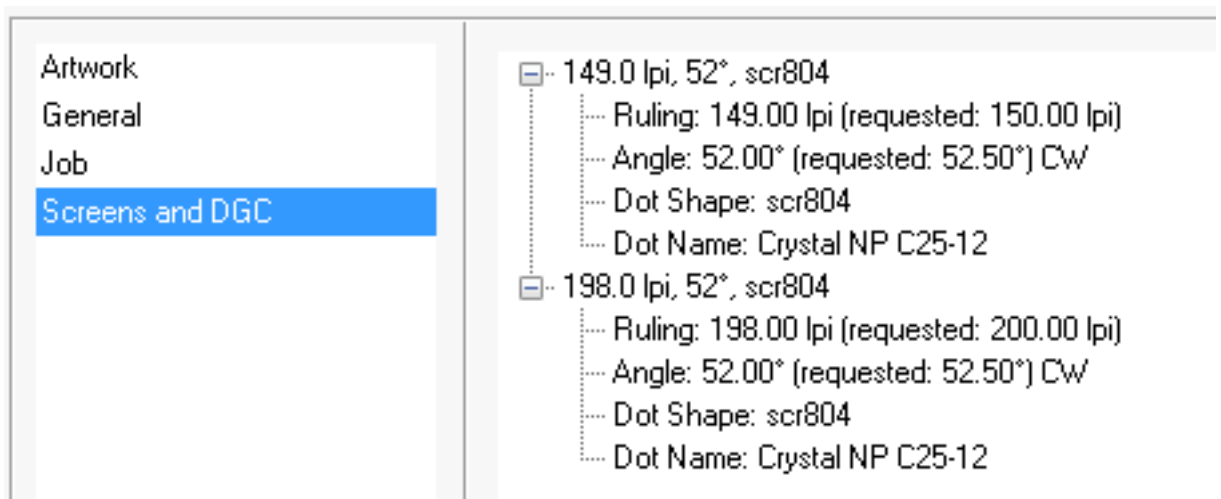

- **Separations:**

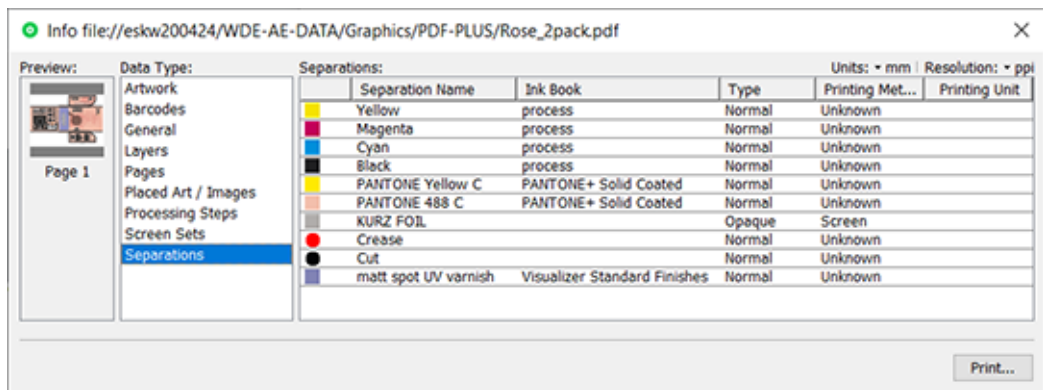

- Separations with a round color patch are so called 'Colorants': These are separations that are only used to color objects in Processing Step Layers. Colorants are not considered as printing inks, as they should not appear on plates or on the final printed result.



**Note:** In normalized PDF files, these were often indicated as 'technical inks'.

- **Type:** Either Normal or Opaque.
- **Printing Method:** Learn more in [Hybrid Press Workflow](#) on page 1957.
- **Printing Unit:** Defining on which printing unit (press tower) a separation will be printed is useful in several use cases. This number is then used in the order of printing marks and can be used as a SmartName to add to the name of RIP output. Learn more in the [ArtPro+ user guide](#) (in **Documents > Separations > Working with Printing Units**).

• **Structural Designs:**

This data type only appears when any such files were placed in the PDF. These can be ARD, one-up CF2, ZAE or DAE files.



**Note:** Placing ZAE or DAE files requires v20 or higher of ArtPro+ .

When a cad file was placed, there is always a link.

Selecting them also allows to check their availability.

**The Info Summary dialog**

When you select more than one file, and then right-click (or use the **File** menu), you can choose between **Info** and **Summary**.

- When you selected 10 or less files, 'Info' will open the various 'Info' dialogs.
- When you selected between 11 and 20 files, you will see a list of files, and an 'Info' panel of the file selected in that list.
- When you selected more than 20 files, you always get a 'Summary' dialog:

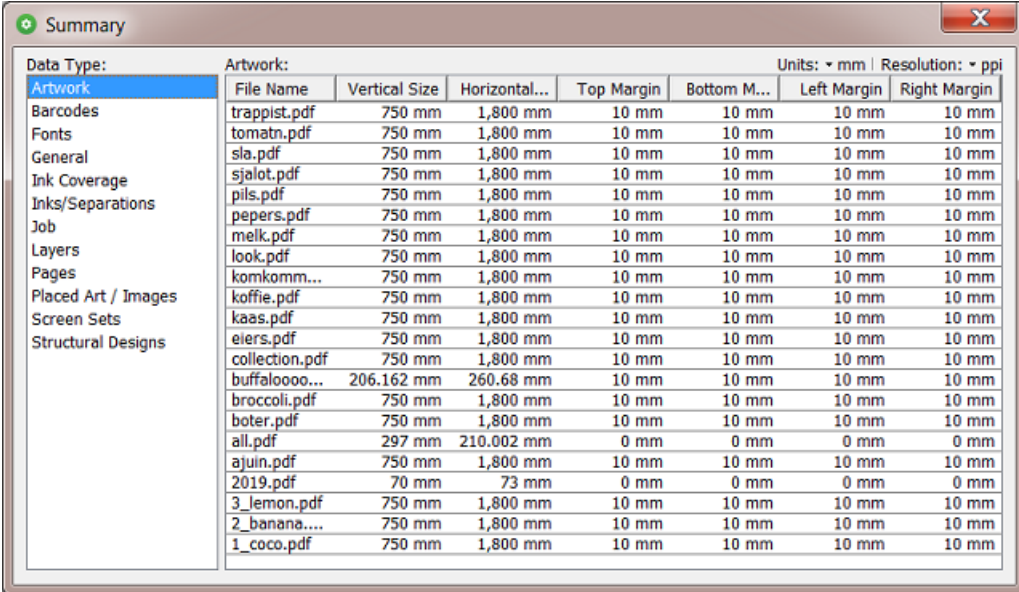

Data Type:	Artwork:							Units: ▾ mm   Resolution: ▾ ppi
Artwork	File Name	Vertical Size	Horizontal...	Top Margin	Bottom M...	Left Margin	Right Margin	
Barcodes	trappist.pdf	750 mm	1,800 mm	10 mm	10 mm	10 mm	10 mm	
Fonts	tomatn.pdf	750 mm	1,800 mm	10 mm	10 mm	10 mm	10 mm	
General	sla.pdf	750 mm	1,800 mm	10 mm	10 mm	10 mm	10 mm	
Ink Coverage	sjalot.pdf	750 mm	1,800 mm	10 mm	10 mm	10 mm	10 mm	
Inks/Separations	pils.pdf	750 mm	1,800 mm	10 mm	10 mm	10 mm	10 mm	
Job	pepers.pdf	750 mm	1,800 mm	10 mm	10 mm	10 mm	10 mm	
Layers	melk.pdf	750 mm	1,800 mm	10 mm	10 mm	10 mm	10 mm	
Pages	look.pdf	750 mm	1,800 mm	10 mm	10 mm	10 mm	10 mm	
Placed Art / Images	korkomm...	750 mm	1,800 mm	10 mm	10 mm	10 mm	10 mm	
Screen Sets	koffie.pdf	750 mm	1,800 mm	10 mm	10 mm	10 mm	10 mm	
Structural Designs	kaas.pdf	750 mm	1,800 mm	10 mm	10 mm	10 mm	10 mm	
	eiers.pdf	750 mm	1,800 mm	10 mm	10 mm	10 mm	10 mm	
	collection.pdf	750 mm	1,800 mm	10 mm	10 mm	10 mm	10 mm	
	buffaloooo...	206.162 mm	260.68 mm	10 mm	10 mm	10 mm	10 mm	
	broccoli.pdf	750 mm	1,800 mm	10 mm	10 mm	10 mm	10 mm	
	boter.pdf	750 mm	1,800 mm	10 mm	10 mm	10 mm	10 mm	
	all.pdf	297 mm	210.002 mm	0 mm	0 mm	0 mm	0 mm	
	ajuin.pdf	750 mm	1,800 mm	10 mm	10 mm	10 mm	10 mm	
	2019.pdf	70 mm	73 mm	0 mm	0 mm	0 mm	0 mm	
	3_lemon.pdf	750 mm	1,800 mm	10 mm	10 mm	10 mm	10 mm	
	2_banana....	750 mm	1,800 mm	10 mm	10 mm	10 mm	10 mm	
	1_coco.pdf	750 mm	1,800 mm	10 mm	10 mm	10 mm	10 mm	

## Processing Steps - Groups and Types

### Groups

In the ISO norm, types of processing steps are grouped as follows:

- **Structural Data:** A collection of contours that describe how the printed product will be finished to produce a 3D end product from a flat substrate. These are as lines defining cutting, creasing, folding etc. The types of this group are listed below.
- **Positions:** Objects that indicate intended, allowed or forbidden positions for certain types of elements. For example the positions on a flap of a carton where content is allowed. The types of this group are listed below.
- **Braille:** Braille characters that are applied after printing, typically by a die cutter or inkjet device.
- **Legend:** Job related data added outside the boundaries of the actual printed products.
- **Dimensions:** Indications of the physical sizes.
- **White:** White ink to be printed on a transparent or metallic substrate.
- **Varnish:** Indicating the application of varnish after printing.

### Types of the group 'Structural Data'

Group	Type	Description
Structural Data	Cutting	Processing step objects indicating where the printed artwork will be cut from the printed sheet e.g. with a guillotine cutter or die cutting device.
Structural Data	PartialCutting	Processing step objects indicating where the substrate will be cut partially i.e. not entirely through the material.
Structural Data	ReversePartialCutting	Processing step objects indicating where the substrate will be cut partially i.e. not entirely through the material on the back side of the substrate.

Group	Type	Description
Structural Data	Creasing	Processing step objects indicating where the substrate will be creased to guide subsequent folding.
Structural Data	ReverseCreasing	Processing step objects indicating where the substrate will be creased on the back side of the substrate.
Structural Data	CuttingCreasing	Processing step objects indicating where the substrate will undergo alternating cutting and creasing.
Structural Data	ReverseCuttingCreasing	Processing step objects indicating where the substrate will undergo alternating cutting and creasing on the back side of the substrate.
Structural Data	PartialCuttingCreasing	Processing step objects indicating where the substrate will undergo alternating partial cutting and creasing.
Structural Data	ReversePartial-CuttingCreasing	Processing step objects indicating where the substrate will undergo alternating partial cutting and creasing on the back side of the substrate.
Structural Data	Drilling	Processing step objects indicating locations where the substrate will be drilled and the intended size of the resulting hole.
Structural Data	Gluing	Processing step objects enclosing an area where glue will be applied.
Structural Data	FoilStamping	Processing step objects enclosing an area where foil will be applied through hot foil stamping.
Structural Data	ColdFoilStamping	Processing step objects enclosing an area where foil will be applied through cold foil stamping (i.e. using glue).
Structural Data	Embossing	Processing step objects enclosing an area where embossing will be applied.
Structural Data	Debossing	Processing step objects enclosing an area where debossing will be applied.
Structural Data	Perforating	Processing step objects indicating where the substrate will be perforated.
Structural Data	Bleed	Processing step objects indicating the intended bleed for print.
Structural Data	VarnishFree	Processing step objects enclosing an area where it is not allowed to have varnish.
Structural Data	InkFree	Processing step objects enclosing an area where it is not allowed to have printing ink.
Structural Data	InkVarnishFree	Processing step objects enclosing an area where it is not allowed to have printing ink and where it is not allowed to have varnish.
Structural Data	Folding	Processing step objects indicating where the substrate will be folded without prior creasing.

Group	Type	Description
Structural Data	Punching	Processing steps objects indicating the locations at which the substrate will be punched and the size and shape of the resulting holes.
Structural Data	Stapling	Processing steps objects indicating the locations at which the substrate will be stapled or stitched, and the size of the staples or stitches to be used.

**Types of the group 'Positions'**

Group	Type	Description
Positions	Hologram	Processing step objects that indicate the intended position of holograms.
Positions	Barcode	Processing step objects that indicate the intended position of barcodes.
Positions	ContentArea	Processing step objects that indicate areas where it is allowed to place text and other graphical elements.
Positions	CodingMarking	Processing step objects specific to packaging that indicate areas where additional information not contained in the PDF will be printed on the packaging at a post-press stage, such as on filling lines where final products are being packed. Some examples of information that might be marked as CodingMarking include but are not limited to best before dates, lot numbers, production dates, and tracking codes.
Positions	Imprinting	Processing step objects that indicate areas where additional information (e.g. variable data) will be printed on pre-printed shells which contain the bulk of the graphical content, as a secondary print stage prior to finishing.

**3.2.4. Which AE task Uses which Technology?**

In the above page [PDF+, Successor or Normalized PDF](#), we already introduced the graphics software kernels that are used in Automation Engine.

We here add more detail.

**Graphics Software Kernels used in Automation Engine**

- **NDL - the ArtPro+ kernel**

'New Document Layer' is the Esko R&D project name given to the native PDF kernel that is used in ArtPro+. This is the latest graphics kernel used by Esko.

For example: The tasks [Add Dynamic Marks](#), [Create PDF Report](#), [Export PDF Info](#) and the 3 Step & Repeat tasks.



**Note:** Before AE 22, the name of many of this type of tasks had a suffix '**(Dynamic)**'. This was because the first of these tasks were also the first ones using Dynamic Marks (and not SmartMarks).

- **NDL \*\*\* - ArtPro+ PDF Action Lists used in AE tasks**



An ArtPro+ operator can, apart from using the interactive editing tools, also execute Action Lists: a series of actions executed interactively on his open file. To also enable executing such action lists also in background on Automation Engine, the NDL kernel is made available on AE, there wrapped in what is called the "PDF Action List Processor" (a.k.a. 'PAL Processor').

AE task types that use this PAL Processor mention this in their ticket dialog ; they are '**Powered by PDF Action List Processor**'.

For example: The tasks [Trap](#), [Optimize PDF](#), [Apply PDF Action List](#).

In the table below we marked these tasks with an '\*\*\*'.

In next versions of AE, more tasks will use this technology.



**Note:** These tasks use the PDF Action List processor that is installed on your Automation Engine.

- "Classic" technologies.



**Attention:** Since Automation Engine 22, the name of the task type has a suffix '**(Classic)**' when it is not (only) using the PDF+ graphics engine that is used in ArtPro+ (see below). These classic tasks use normalization technology or native formats like ArtPro, technologies that since AE 22 we refer to as 'classic' technologies.



**Note:** Mind the difference between 'Classic' and 'Soon outdated':

- A task type is labeled 'Classic' to help you separate the use of different graphics technologies. Although classic technologies are older than other default ones, this does **not** mean these tasks will be soon outdated. It is of course also a hint and invitation to start using the more recent technologies (as used since the ArtPro+ generation).
- When a task is labeled 'Soon outdated', it means what it says. This type of task still works in this version but may stop working in a next major version. It is a warning that advises you to start checking the offered alternative task type or workflow. Learn more in [Concept of \(Soon\) Outdated Tasks / Features](#) on page 531.

- **BRIX**

For example used by the classic tasks 'Trap with PowerTrapper', 'Add SmartMarks', 'Export Gang Run Layouts', 'Manage Color'.

- **BRIX \***

Some BRIX tasks have a special behavior. We marked them in the table below with an '\*'.

These BRIX tasks can handle native PDF in and out *without* normalizing it. These are:

- The i-cut tasks. This for example allows i-cut workflow users to keep RGB data till output.
- The Step & Repeat tasks that are labeled 'Classic' and that offer the output format 'PDF' in their ticket.

- **ArtPro**

The proprietary ArtPro format. For example used by the classic task 'Apply ArtPro Action List' (AP file in, AP file out).

- **Enfocus**

- **Enfocus PitStop**

The task 'Preflight with PitStop' and 'Verify Certification' use the PitStop Server software on board Automation Engine.

Normalized PDF files can only be preflighted when, in the preflight profile, the option "Allow fixes" is switched off. PDF Action Lists can never be executed on Normalized PDF files.

- **Enfocus library \*\***

Next to PitStop, Automation Engine also uses an other Enfocus software library to execute prepress tasks on PDF. We marked them in the table below with an '\*\*'.

For example the classic tasks 'Optimize PDF Document', 'Optimize PDF Pages', 'Extract Inks'.

These tasks can be launched on normalized PDF as well.

- **Other / none.** These tasks do not use any of the above mentioned graphics kernels. For example the tasks 'Copy or Move File', 'Create XML', 'Create Job', Some even use 3rd party technology, like the 'ZIP', tasks or the various Inspection tasks powered by GlobalVision, etc.

### Which Graphics Kernel does this Task use?

\* = BRIX tasks that can handle native PDF (without normalizing on the fly).

\*\* = Enfocus PDF library for prepress tasks (not using PitStop).

\*\*\* = Powered by PDF Action List Processor. These use the PAL Processor installed on the AE server.

Task name	BRIX	ArtPro	Enfocus	NDL	Other
Add Dynamic Marks				V	
Add Ink Eaters (Classic)	V				
Add Margins to LEN File					V
Add Marks to Imposition					V
Add Parameters for Nesting (Classic)	V *				
Add SmartMarks (Classic)	V				
Add to Pages View (Classic)					V
Add to Products					V
Adjust PDF Screening (Classic)			V **		
Adjust PDF Screening				V***	
Apply ArtPro Action List (Classic)		V			
Apply Creep					V
Apply PantoneLIVE Condition (Classic)			V **		
Apply PDF Action List				V ***	
Apply Plate ID to LENX File					V
Archive Job					V
Assign PDF Pages to RunList					V
Calculate Ink Key Settings (CIP3)					V

Task name	BRIX	ArtPro	Enfocus	NDL	Other
Calculate Ink Key Settings (InkPlanner)					V
Change Imposition Layout					V
Change Location ...					V
Check Dynamic VDP Database					V
Check Job Parameters (Classic)	V				
Check Print Rules (PRC)(Classic)	V				
Check Product Parameters (Classic)	V				
Check Technical Inks (Classic)	V				
Compare PDF (Classic)			V **		
Contourize & Clean (Classic)	V				
Convert CMYK Colors (Classic)	V				
Convert Colors for Digital Printing (Classic)	V				
Convert Colors with Equinox (Classic)	V				
Convert IMP File to Normalized PDF File (Classic)	V				
Convert JSON to XML					V
Convert Selection					V
Convert to ARD/MFG					V
Convert XML to JSON					V
Copy or Move File					V
Create ArtiosCAD Layouts					V
Create ArtiosCAD Report from XML					V
Create Design (DesignWizard)(Classic)	V				
Create IMP File (Classic)	V				
Create Imposition from JDF Layout					V
Create Imposition from RunList					V
Create Imposition Sheet Report					V
Create Imposition					V
Create Job Report					V
Create Job					V
Create Master DCS File (Classic)	V				
Create Merged Plate					V
Create or Modify WebCenter Project					V
Create Packshot from XML					V
Create PAF / JPG / XML (LinkEdge)(Classic)	V				

Task name	BRIX	ArtPro	Enfocus	NDL	Other
Create Flexo Plate Cutting Paths				V ***	
Create PDF File from JDF RunList (Classic)			V **		
Create PDF File from RunList					V
Create PDF Report				V	
Create Report (ReportMaker)(Classic)	V				
Create RunList from PDF					V
Create RunList					V
Create Sheet Layout (Classic)	V				
Create or Modify WebCenter Project					V
Create Sheet Layout (Classic)	V *				
Create Tiles (Classic)	V *				
Create Wrapper File (Classic)	V				
Create XML File					V
Crop LEN File					V
Delete File					V
Delete Product on Esko Cloud					V
Download Files from Shared Job					V
Download Product from Esko Cloud					V
Download WebCenter Document					V
Enrich Black (Classic)	V				
Expand Dynamic VDP Data				V	
Expand Variable Data to PPML File (Classic)	V				
Expand Variable Data to PPML File (DeskPack only)(Classic)	V				
Export ArtiosCAD Design Info					V
Export ArtPro to Normalized PDF File (Classic)		V			
Export IMP File to ...					V
Export Imposition to ...					V
Export Kongsberg Cutting History					V
Export / Import Picture List				V ***	
Export Gang Run Layouts	V *				
Export PDF Info				V	
Export Step & Repeat to JDF Layout (Classic)	V				
Export Step & Repeat to JDF Layout				V	

Task name	BRIX	ArtPro	Enfocus	NDL	Other
Export to 3D (Classic)	V				
Export to 3D				V	
Export to ArtPro File (Classic)	V				
Export to EPS/DCS File (Classic)	V				
Export to Gravure using HELL Job Ticket				V	
Export to Normalized File (DeskPack Only) (Classic)	V				
Export to Normalized PDF File (Classic)	V				
Export to PDF File (Classic)	V				
Export to PostScript File (Classic)	V				
Export to Unscreened Separations				V***	
Extract Inks			V**		
Fill Printing Lanes					V
Generic Brix (Classic)	V				
Image to Content Proof (RGB)					V
Image to Unscreened Proof					V
Image to screened/unscreened separations					V
Import Die					V
Import Image (Classic)	V				
Import JDF Layout (Classic)	V				
Import JDF Step & Repeat (Classic)	V				
Import JDF Stripping (Classic)					V
Import Order Material from XML					V
Import Substrate Sizes from XML					V
Inspect ... (GlobalVision tasks)					V
Integrate via External Hot Folder					V
Integrate with WebCenter					V
Interact using JDF					V
Interact using JMF					V
Interact with Database					V
Interact with SAP					V
Interact with Web Service					V
Join XML Files					V
Link Product to Job					V

Task name	BRIX	ArtPro	Enfocus	NDL	Other
Load Structural File (Classic)	V				
Manage Color (Classic)	V				
Manage Milestone					V
Manage Product Status					V
Map Data					V
Mark as Proof					V
Mark File					V
Merge PDF Files (Classic)			V **		
Merge PDF Files				V	
Normalize PDF File (Classic)			V **		
Normalize PostScript / PDF / Illustrator 8.0 File (Classic)	V				
Normalize TIFF/IT File (Classic)	V				
Optimize and Clean (PSFix)(Classic)	V				
Optimize PDF Document (Classic)			V **		
Optimize PDF Separations (Classic)			V **		
Optimize PDF				V ***	
Outline Fonts (Classic)	V				
Prefix Products on Esko Cloud					V
Preflight Color for Digital Printing					V
Preflight Color for Equinox	V				
Preflight with PitStop			V		
Prepare for Inspection (Classic)				V	
Prepare for Sharing				V***	
Prepare for Viewer	V				
Prepare Graphics for Nesting (Classic)	V *				
Prepare Station (Classic)	V				
Proof for Content Approval					V
Proof for Contract Approval					V
Process PDF Spreads (Classic)			V **		
Publish Imposition on WebCenter Chain					V
Publish on WebCenter	V				
Relocate Job					V
Remove Files from Shared Job					V

Task name	BRIX	ArtPro	Enfocus	NDL	Other
Remove Job					V
Remove Product					V
Resize PDF for Output (Classic)			V **		
Resize Shape					V
Resolve OPI (Classic)			V **		
Restore Job					V
Reverse Trap				V***	
Run ArtiosCAD Standard					V
Run Script					V
Select Files on Shared Job					V
Select File					V
Send E-mail					V
Share Job					V
Split PDF File (Classic)			V **		
Split XML File					V
Start Approval Cycle on Share & Approve					V
Step & Repeat CAD based (Classic)	V *				
Step & Repeat CAD based				V	
Step & Repeat Tabular based (Classic)	V *				
Step & Repeat Tabular				V	
Step & Repeat Template based (Classic)	V *				
Step & Repeat Template based				V	
Submit to Esko / Generic DFE					V
Submit to Flexo Device					V
Submit to Gang Run (Classic)					V
Submit to HP SmartStream Production Pro Print Server					V
Submit to Kongsberg Table					V
Submit to Plate Merger					V
Submit XML to Gang Run (Classic)					V
Synchronize ArtiosCAD Boards					V
Synchronize ArtiosCAD Companies					V
Trap with PowerTrapper (Classic)	V				
Trap				V ***	

Task name	BRIX	ArtPro	Enfocus	NDL	Other
Unshare Job					V
Unzip					V
Upload Files to Shared Job					V
Upload Files to Share & Approve					V
Upload Product to Esko Cloud					V
Upload to Cloud Storage					V
Upload to SFTP					V
Upload via FTP					V
Verify Certification			V		
Version PDF (Classic)			V **		
Wait for Action (Checkpoint)					V
Wait for Approval on Share & Approve					V
Wait for Files (via JDF)					V
Wait for Files					V
Wait for Product Status					V
Wait					V
Zip					V

\* = BRIX tasks that can handle regular PDF (without normalizing on the fly)

\*\* = Enfocus PDF library for prepress tasks (not using PitStop)

\*\*\* = Powered by PDF Action List Processor. These use the PAL Processor installed on the AE server.

### 3.2.5. Workflow and Current Limitations

#### PDF+ Workflow

A native PDF workflow in Automation Engine (or Imaging Engine) is one where the one-up PDF stays a PDF+ during all typical prepress steps.

Such a workflow requires that all its prepress tasks need to use the PDF+ technology (the NDL kernel) so that the production PDF file stays a PDF+ file.



**Note:** Of course many Automation Engine tasks do not use any graphics kernel (see the [list above](#)).

However, Esko can not offer all migrated technology in one go, in one software update. Until then, you may have to rely on **mixed workflows where NDL tasks are used in combination with BRIX tasks and/or Enfocus PDF tasks**.

This means that, in the current version of Automation Engine, your workflow may still need tasks that normalize the PDF. Some of those tasks will do that all the time and also do it explicitly (creating *also* a



normalized PDF). Some will do that hidden, on-demand (a first stage of the task that starts by creating a hidden and temporary, normalized PDF).

**In this and next versions of Automation Engine, the need to create normalized PDF files in a workflow will eventually become an exception. This will be done both by adapting BRIX based tasks and by introducing new NDL based tasks.**

### Limitations

When opening or using a PDF+ file as input, the current version of Automation Engine and these tools will still normalize the PDF file:

- **Esko tools / applications** that will normalize in this same version:

- Classic editors PackEdge, ArtPro, Plato, i-cut Layout



**Note:** i-cut Layout ignores the metadata in PDF+ files, i.e.: the extra metadata is not used.

- AE Viewer and WebCenter when the classic technology 'As in PackEdge'
  - FlexRip, FlexProof (Soon Outdated)
- **AE Tasks** that will still normalize:  
See them listed above in [Which AE task Uses which Technology?](#) on page 66.

### Migrating to native PDF

Learn more about this topic in the dedicated white paper "Migrating your Packaging Prepress to native PDF". Find it in the section "Related Documentation" under the [Automation Engine online help](#).

## 4. Getting Started

---

### 4.1. Installing Server and Clients

---

This needs to be done first before you can use Automation Engine from any client (application or browser):

1. Install the Automation Engine server software, on a central powerful computer.



**Important:** Before installing the server software, make sure your IT specialists checked its [system requirements](#) and have read the chapter [Pre-Install IT Requirements](#) on page 1962.

2. Install the Automation Engine client application Pilot and/or Shuttle. Unless you prefer to use the browser client (see step 3), you typically install these on each computer from where users will want access to Automation Engine. You can install as many as you want, but your licenses decide how many users can be signed in to the server at the same time.



**Note:** These client applications and other tools can be downloaded from the browser client (go to <http://<AEServerName>:9000/#/downloads>).

3. Daily users may use the browser client. This does not require to install a separate application. The [browser client](#) can offer these 2 workspaces:
  - **My Workspace:** A default, generic interface to launching workflows. Learn more in [Workspace 'My Workspace'](#) on page 891.
  - **Roll-Fed Labels:** Formerly known as the QuickStart deployment for roll label production. Learn more in [Workspace 'Roll-Fed Labels'](#) on page 897.

All steps are documented in detail in the chapter [Installation Guide](#) on page 1982.

### 4.2. Changing the Language used in the Pilot, Shuttle or browser client

---

The client applications Pilot and Shuttle are available in several languages (aka "Localization"). [This online KB article](#) describes how you can specify that language.

In the browser client, changing the interface language is a simple choice in the preferences menu.

### 4.3. Signing In to the Pilot or Shuttle

---



**Note:** Learn about managing users on the page about [the Users view](#). Learn more technical details in the chapter [Pre-Install IT Requirements](#), on the pages about [Users and Groups](#).



**Note:** The Pilot, browser client and Shuttle are available in several languages. Learn more in [Changing the Language used in the Pilot, Shuttle or browser client](#) on page 76.

On the computer where you installed a Pilot or Shuttle:

1. Double-click the application shortcut.
  - On macOS: in the folder **Applications** or in your **Dock**.
  - On Windows: on the desktop or in the task bar. Alternatively, find it under **Start > All Programs > Esko**.
2. The **Sign In** dialog looks different, depending on whether you already used it on this computer or whether it was already used to sign in to a different Automation Engine server.
  - When this is the first time, you will be asked to first enter the name or the IP address of your Automation Engine server. Do so and press **Continue**.

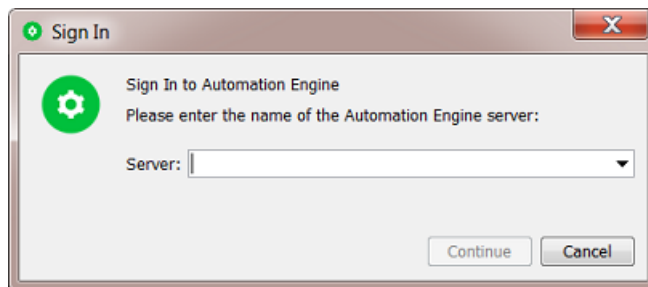

From then on, the drop-down list will list other servers that were signed in to from this client.

- When someone already signed in from this computer, the dialog already assumes the same Automation Engine server and also fills in the name of that previous user.

You then only need to type the password and click **Sign In** (or you use another user name and password).

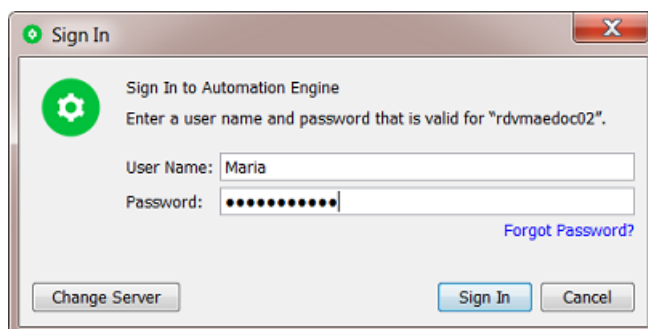

- Click **Forgot Password?** to get an e-mail with a link to reset your password. The e-mail is sent to the e-mail address defined for that user. Learn more in [Users View](#) on page 153.



**Important:** Make sure the e-mail configuration is set up in your [Configure tool](#). This dialog does not show any error messages when the sending of this e-mail fails.

- Click **Change Server** if you want to sign in to another Automation Engine server. You then get the dialog as shown here above.



**Note:** Every time you select another server, the dialog also checks whether this client version matches the version of that server.

- The **Advanced...** button appears when choosing a server. It allows to define **Advanced Options**.

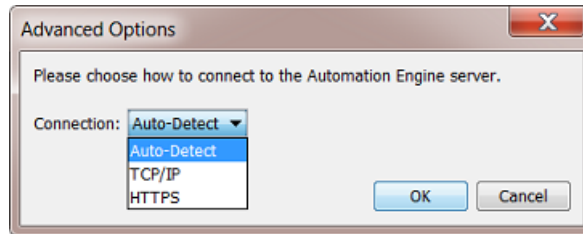

- **Connection:**

- By default, when connecting to an Automation Engine server, the Pilot automatically chooses the connection mode (**Auto-Detect**).
- When the Automation Engine server has a site-local address (e.g. 10.\*.\* or 192.\*.\* or the range 172.16.0.0.0 - 172.31.255.255) the connection will use **TCP/IP**, otherwise **HTTPS** is used.
- The default behavior assumes that an *AE SaaS server* has a public IP address and that an AE server on-premises has a private IP address. The latter will not always be true. So in that case a Pilot user can manually set the connection mode to TCP/IP. This forces the Pilot to use a TCP/IP connection even when the IP address of the server is not a site-local address.
- This setting is remembered for future sign-ins.

**3.** Possible messages or problems when signing in:

- When the attempt to sign in does not succeed immediately, you will see an extra dialog with a **Cancel** button. This button is useful when you noticed that you for example mistyped the server name, or when you just now remember that this client computer or the server is offline.

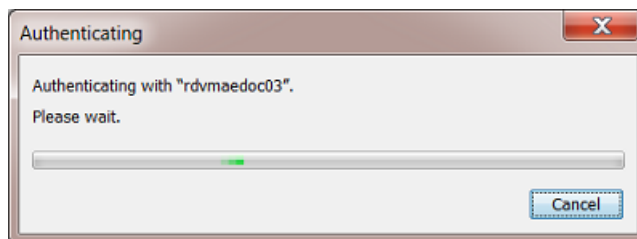

So when you know there is no point in waiting, click **Cancel** to stop the authentication attempt immediately.

- When a sign-in fails, you will be told if the problem is a wrong combo of the user name and password you entered. In other cases, the message will, for security reasons, not add too many details on the cause. It could be that you just mistyped the server name or any other type of problem (network, server software not running, etc.)



When you are sure that your user name and password were correct, click **Connection Doctor...** to start a first analysis of the problem. Learn more in the chapter [Troubleshooting](#) on page 2060.

- When the version of the client software (the build nr.) is different from the one on the Automation Engine server (typically the case right after the server software was updated), this dialog will pop up:

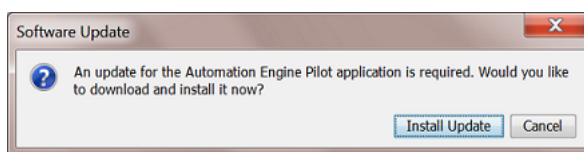

Click **Install Update** to download the update. At the end of the download, the message "Ready to install" appears. Then click **Install and Relaunch** to install the update on this client. When finished, the Sign In dialog will be shown again.

On Mac, you need to enter the credentials of an administrator user to update the Pilot application.

- When the system can't even find the sign-in options to offer to the client, then the version of the server software is probably an older major version number. For example: The client software is v20 but the server is still on v18.1.

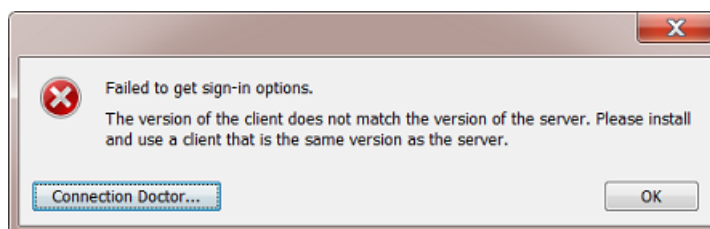

**Note:** It is possible to sign in to multiple Automation Engine (master) servers. Administrators may need this functionality in special cases, like server migrations. To do this, sign in to the Pilot of server 1, and in the resulting Pilot's File menu, ask a **New Connection**. This will open an extra sign-in dialog where you can sign in to an other AE master server.



## 4.4. The Pilot's Main Window

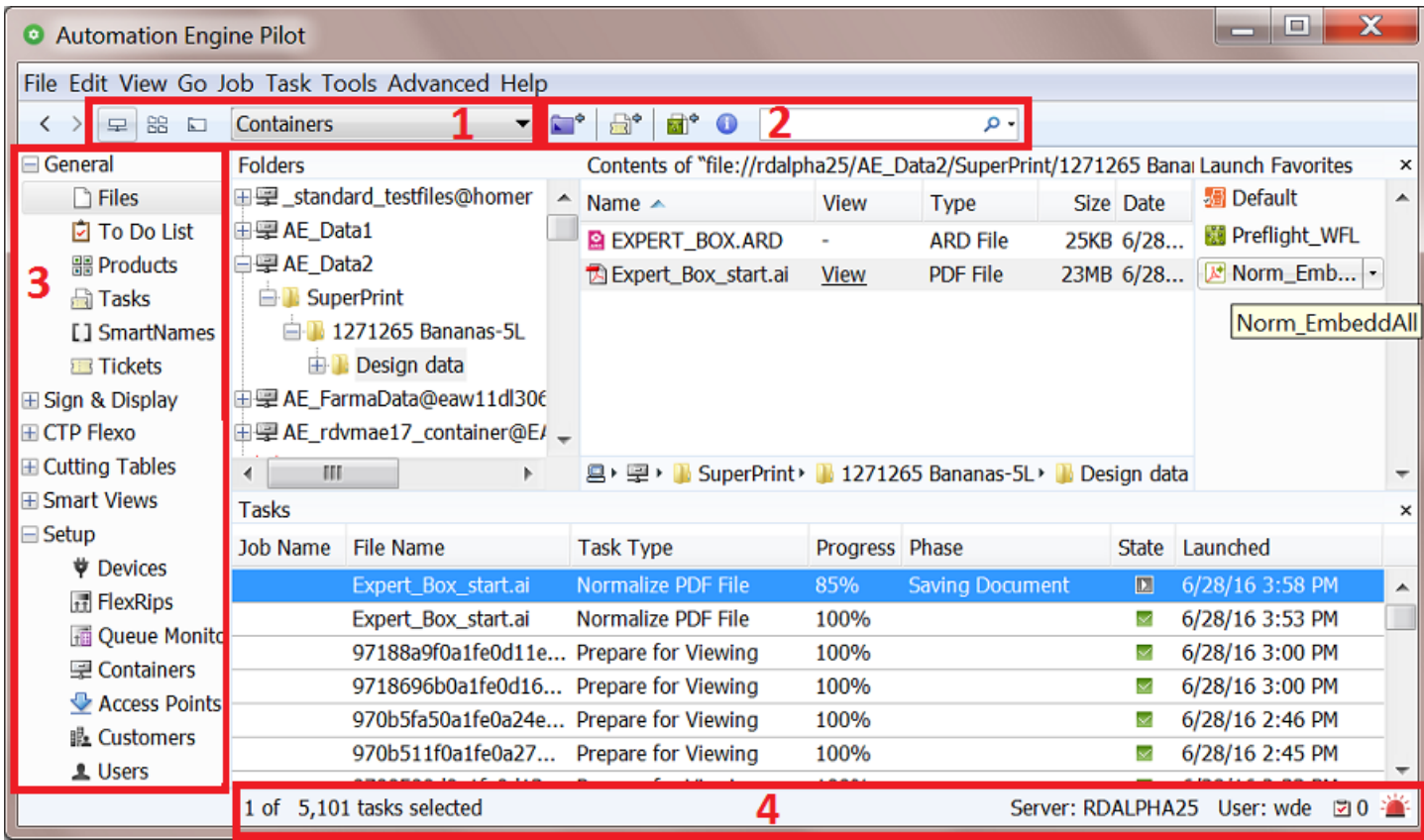

**Note:** The Pilot's user interface and its View modes are introduced in some of the "eLearning Modules" that you can follow on the [Esko Blended Learning platform](#).







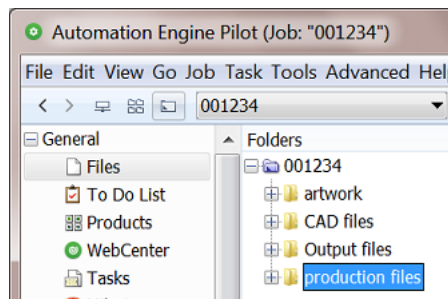

1. The Pilot offers three **View modes**:

- 
**Containers:** This mode allows to access all **Containers**, which contain the network data that Automation Engine is allowed to work with. Learn more in [Containers](#) on page 146.
- 
**Job Overview:** This mode lists all **Jobs** existing in the Automation Engine Jobs database. Learn more in the dedicated chapter on [Jobs](#) on page 538.
- 
**Last used Job:** This mode shows the last Job you opened, and the data in its **Job Folder**.



2. The top tool bar:

-  **Create Job** allows you to create a **Job** in the Jobs database. Learn more in the chapter [Jobs](#) on page 538.
  -  **New Task** allows to launch a new task on the current selection.
  -  **New Workflow** opens the workflow editor to create a new Workflow ticket. Learn more in the chapter on [Workflows](#) on page 733.
  -  shows information about the selected **Job** or file.
  - A search field that also allows to create filters.
3. The **Views** pane allows to focus on specific functionality of Automation Engine. Certain Views are only shown in specific view modes. Learn more in [Pilot Views and Tools](#) on page 113.
4. The bottom bar offers this information:
- Left side: info on your current selection (could be files, tasks, jobs, etc.)
  - Right side:
    - Name of the **Location** of this server setup. A Location name is used (and here visible) when several Automation Engines collaborate via Esko Cloud.
    - Name of the **Server** computer.
    - Name of the current **User** that logged on to this Pilot.
    - Amount of **to-do** items for this user. Click  to open the 'To Do List' tool and see all to-dos.
    - Amount of **Alerts**. Click  to open the list of alerts. Learn more in [Alerts](#) on page 2060.

The contents of the central panes depends on the selected view **Mode** and **View**.

### Using Tabs to enable Multiple Views

Tabs allow you to have multiple Views open in your Pilot.

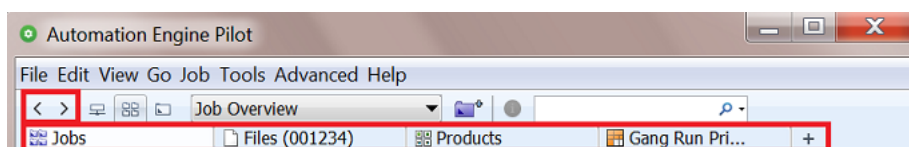

In any view, use any of these methods to create a new tab:

- Choose **File > New Tab** or use the shortcut **Ctrl-T** (Windows) or **Cmd-T** (Mac).
- Once a tab bar is visible, you can also create a new tab
  - by clicking .
  - by right-clicking on the tab bar and choosing **New Tab**.

You can close tabs by using similar tools.



**Note:** To close all other tabs but the current one, choose **File > Close Other Tabs**.

### Smart Views

You can use the filter tool to create filters for specific views. When you save such a filter, they are listed in the **Views** pane, in the category "**Smart Views**". so you can easily re-select them from there. Learn more in [Smart Views](#) on page 138.

## 4.5. Concepts of Tasks, Tickets and Workflows

---

### 4.5.1. Tasks

#### What is a Task?

A task is a background action executed on one or multiple files, folders or items in an Automation Engine database. A task can be started by a user, by an external system or be triggered automatically by Automation Engine itself.

There are many types of tasks:

- **Conversion** tasks such as **Export to PDF, Export to PostScript...**
- **File Creation** tasks such as **Step & Repeat, Create 3D file...**
- **File Editing** tasks such as **Optimize PDF, Split Pages, Trap...**
- **Verification** tasks such as **Preflight, Inspect Braille...**
- **Administration** tasks such as **Copy or Move, Upload via FTP, ZIP...**
- **RIP** tasks.
- **Device Output** tasks, communicating with CDI imagers, Digital presses or Kongsberg cutting tables.

#### Task Settings

A task are defined by many settings: these are

- the attributes of the task itself (for example its priority and the user who launched it),
- its parameters, usually saved as a task *Ticket*. These decide the specifics of what is executed in background (for example a chosen resolution).

#### Task Progress

When a task is launched, you can monitor its progress and end status. Learn more in [Checking the Status of a Task](#) on page 88.

### 4.5.2. Workflows

A **workflow** ticket contains multiple **steps**. Launching a workflow results in multiple tasks. A workflow step can be



- a single task ticket
- a **workflow control**
- a **subworkflow** (included or referenced).

An example:

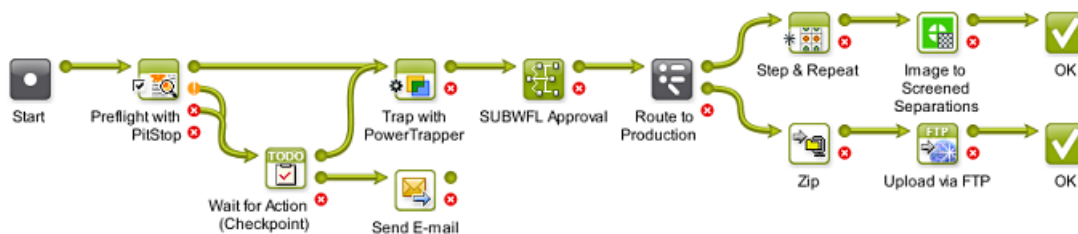

Just like single task tickets,

- you can launch workflow tickets from the **Pilot**, from the *Shuttle* or from within most Esko editors
- workflows can also be launched automatically, triggered by external signals (files arriving on access points, commands from external systems, etc.).

You can build and launch **workflows** in the *Workflow Editor*. Learn more in the dedicated chapter on *Workflows* on page 733.

### Task Chains (old workflows)

**Task Chains** are old workflows from Esko's former workflow server BackStage . They are still supported in Automation Engine but will need to be migrated.

A **Task Chain** is a linear succession of tasks, linked together in a Task Chain ticket.



You can build new **Workflows** from these old Task Chains, while keeping all your tickets settings. Learn more in *Migrating Old Task Chains* on page 872, a page in the chapter *Workflows* on page 733.

## 4.5.3. Tickets

### What is a Ticket?

A **Ticket** is a collection of parameters of a specific **Task** type. When a user (or system) selects files and launches a Ticket, a **Task** is executed on the server.

### Default and Custom Tickets

There is a default ticket for each task type. You can also create custom tickets. You cannot overwrite or delete default tickets.

The [Tickets View](#) shows all available tickets (default and custom).

### Workflow Tickets

A **Workflow Ticket** contains the steps and parameters of several tasks. Its is also referred to as "a Workflow".

### Global and Job Tickets

- **Global Tickets** (🌐) can be used on any file inside a **Container** (network areas that you allow Automation Engine to work with).
- **Job Tickets** (📁) can only be used on data inside the **Job Folder** of the **Job** you saved them for. Learn about Jobs in the chapter [Jobs](#) on page 538.

### Public Tickets

Public Tickets are tickets that all Pilot users can see and use. These are also the ones you can launch from a browser client, from [Shuttle](#) or directly *from within Esko editors*.



**Note:** Depending on your [User Access Rights](#), you may only see public tickets, and **Public Parameters** inside these tickets.



Learn about making tickets public [here](#).

## General Ticket Functions

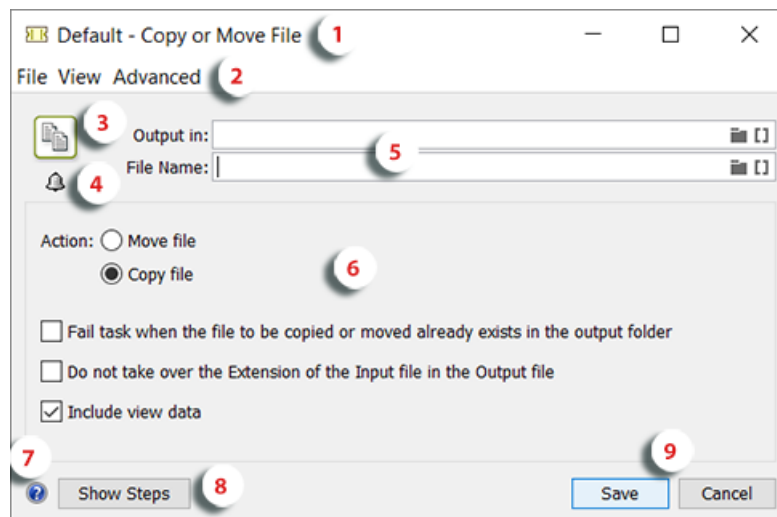
### A Ticket opened from the Tickets View



1. The top bar of the dialog shows an icon indicating the type of ticket (🌐 = Global ticket, 📁 = Job ticket), followed by the name of the ticket and the type of task.

2. Menu items
  - **File** menu (standard functions).
  - The **View** menu is only relevant when having selected input files first (see below section of this page).
  - The **Advanced** menu is where you can **Manage Public Parameters**. Learn more in [Using Public Parameters in Automation Engine](#) on page 99.
3. An icon of the task type.
4. Click  to add **Notifications** that will be executed when the task is launched (or finished). When a ticket includes notifications, the icon changes to . Learn more in [Task Notifications](#) on page 98.
5. Fields to specify the name and place of the files that this ticket creates. Typically, SmartNames are used. Learn more in [SmartNames](#) on page 637.
6. The Parameters for this ticket.
7. Click  to see the online help page for this task type.
8. "**Show Steps**" is only relevant when you still have old "**Task Chains**" (a technology used before "Workflow Tickets". Learn more in [Old Task Chains](#).
9. Click **Save** to save the ticket and all its parameters. When you opened a default ticket, you will be asked to **Save As** another name. Click **Cancel** to close the ticket without saving.

### A Ticket opened after first making a File Selection

When you first selected an input file for a task ticket, the dialog actually shows more than a ticket: You now see a ticket + input files + all settings to launch it.

This is why the dialog looks slightly different:

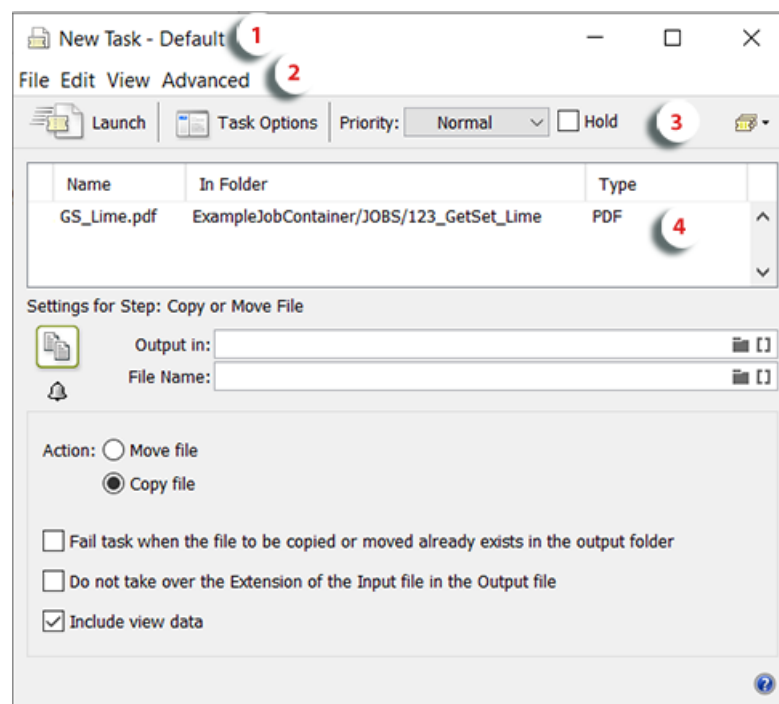

1. The title of the dialog now mentions the way this dialog was opened + the name of the selected ticket.

In above example, a user first selected a file in the Files view, then chose 'New Task' and then selected the default ticket of the task 'Copy or Move File'.

2. Two extra topics in the menu bar:

- **Edit:** When you are viewing the list of input files (see below item 4), you here find the two possible actions. Learn more below.
- **View**
  - **Show Files:** To show or hide the pane that shows the input files. Learn more in below item 4.
  - **Task Options...:** See below item 3.

3. An extra Task related menu bar:

- **Launch:** Launches this ticket on the selected input files and closes this dialog.
- **Task Options:** Learn more in the chapter explaining workflow tickets, which mainly offer the same options: [General Workflow Task Options](#) on page 789.
- **Priority:** Choose the general priority with which you want to launch this task. The default is **Normal**.



**Note:** To choose **High** or **Immediate**, you need a special [User Access Right](#).



**Attention:** Depending on the current load on Automation Engine's workflow engine, the request to start immediately and so bypass all other tasks is best only used occasionally.

- **Hold:** Check this when you want to hold the task when you launch it. The task will start but will immediately go into 'pause' mode. You can then later decide when to release it, i.e. start it for real. Learn more in [Functionality on items in Tasks View](#) on page 126.
  - A ticket selector: Exceptionally, you can still select a different ticket for this dialog.
4. The input files. You can still
    - Select and delete files from this list (use the delete shortcut or **Edit > Clear**).
    - Add extra input files to this list. Right-click in this pane to **Select File...**



**Important:** In this dialog, using the **Save Ticket (as...)** function will still only save the ticket parameters, just like in the first example on this page. A saved ticket never contains information on input files or on task related options.

## 4.6. First Steps in Launching Tasks

### 4.6.1. Launching a Task on a File

There are several ways to launch a tasks: from the Pilot, from Shuttle (plug-in), via Access Points or via JDF/JMF.

We here describe how to launch a task from the Pilot's **Files** view.



**Note:** Before you can launch **RIP** or **Proofing** tasks, you need to configure the matching RIP. Learn more [here](#).

1. In the Pilot, choose the **Containers** mode and select the **Files** view in the **Views** pane.



**Note:** If you don't have any custom **Containers** yet, simply drag a file from outside the Pilot onto a folder in your **ExampleJobContainer**. Learn more in [Uploading files using the Pilot](#) and in [Creating a Container](#) on page 147.

2. Browse to your chosen file. Right-click it, and select either
  - **New Task** if you want to open the ticket that you will select and check or change some of its settings before launching the task.
  - **Launch with** to immediately launch the task without opening the selected ticket.



**Note:** If you don't have the [access right](#) **Tickets: Show All Tickets and their Parameters (Public and other)**, you will only see **'Launch with'**. In this case, you can only select **Public** tickets, and only fill in [Public Parameters](#) in the ticket.

3. Select the ticket to use.
  - If you have launched tasks previously, the most recent task tickets you used are listed. One ticket is shown per task type. A small arrow indicates there were several tickets launched of this task type.

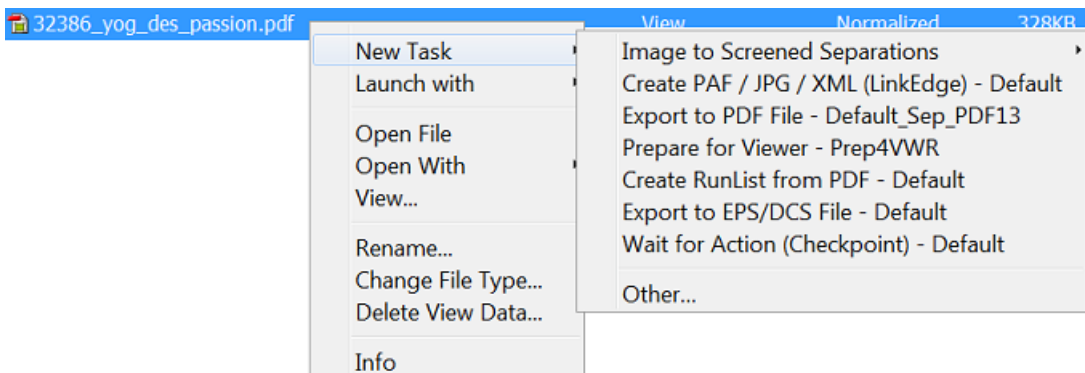

- If you didn't launch tickets yet, or if you need a different ticket, select **'Other'**. Then select the ticket you want to use and click **OK**.



**Note:** This list only shows the tickets of task types that can be launched on the file type that you selected. You can either choose a **Default** ticket or a custom ticket that was [created earlier](#).

4. Now choose one of these launching methods:

- If you chose **New Task**, the selected ticket opens. Fill in the settings you want to use and click  **Launch**.
- If you chose **Launch with** and you have the access right **'Tickets: Show All Tickets and their Parameters (Public and other)'**, the task is launched on the file as soon as you select the ticket. You don't need to fill in any settings.
- If you chose **Launch with** and you don't have the access right **'Tickets: Show All Tickets and their Parameters (Public and other)'**, the task is launched on the file
  - as soon as you select the ticket if the ticket has no [Public Parameters](#).
  - If the ticket contains **Public Parameters**, it will first open for you to fill them in (you will only see the public parameters). Click **Launch** when you are done.



**Note:** For a description of all of the ticket's parameters for each task type, see the chapter [Tasks and Workflow Controls](#) on page 249.

### 4.6.2. Checking the Status of a Task

After launching a task on one or several file(s), you can check its processing status in the Pilot's **Tasks** pane (present in many Views).

File Name	Task Type	Ticket Name	Progress	Phase	State	Launched	Operator
Bike_report.pdf	Delete File	Default	100%			3/7/16 11:19 AM	lola@rdvmae17
BigBox.pdf	Wait for Action (Checkpoint)	Default	0%	<a href="#">User intervention needed</a>		3/3/16 2:53 PM	wde@rdvmae17

You can see the **Progress** (in percentage) and the processing **State**. The state can be:

- on hold
- on hold until
- running (for a Checkpoint task: waiting to be handled)
- waiting (in the queue)
- successfully done
- part of workflow successfully done
- done with warning
- failed
- cancelled

You can also double-click the task's entry in the **Tasks** pane to open your task ticket and check its parameters.

### 4.6.3. Relaunching a Task

You can easily relaunch tasks, even when they are not finished yet.

- To relaunch one or multiple tasks without changing its settings:
  - a) Select the task(s) in **Tasks** view or the **Tasks** pane in another view.
  - b) Click CTRL-L (CMD-L) or go to **Task > Relaunch**.
- To first change its settings and then relaunch a task:
  - a) Select the task to relaunch.
  - b) Double click the task or go to **Task > Open Task**.
  - c) Change the task settings as necessary.
  - d) Click  **Launch**.

### 4.6.4. Launching Workflows

How to create and launch workflows is described in the separate chapter [Workflows](#) on page 733.

### 4.6.5. Creating Task Tickets

#### Creating a Custom Ticket from the Tickets View

To create a custom ticket:

1. Open the **Default** ticket of that task type.



**Note:** To create a custom **Workflow** ticket, see the chapter [Workflows](#) on page 733.

2. Select the wanted ticket parameters.
3. Go to **File > Save As...** or use the keyboard shortcut.
4. In the **Save As** dialog:

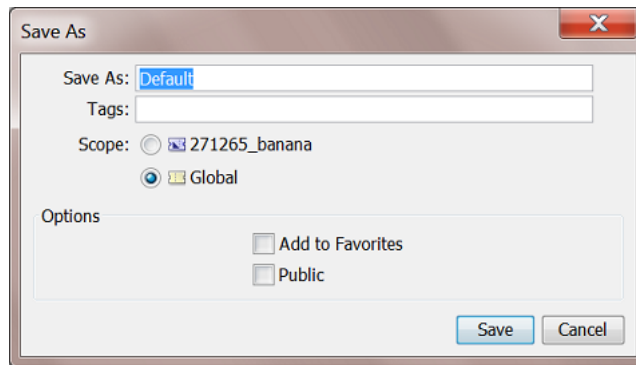

- a) Enter the name of your new ticket. You can not overwrite a default ticket.



**Attention:** Ticket names are case-sensitive.

- b) Add one or more **Tags**. This will help to sort and filter tickets.
- c) Decide the **Scope** of the ticket: only to be seen and used in the (currently selected) **Job** or set them **Global** (possible to use in all Jobs).
- d) Select if you want to add the ticket to your **Favorites**.
- e) Select **Public** if you want to show this ticket to all Pilot users and/or if you want to use it from a browser client, from [Shuttle](#) or [from Esko editors](#).



**Note:**

- **Default** tickets and **Job** tickets can not be made **Public**.
- In the [Tickets view](#), Public tickets have a mark in the column '**Public**'.



**Note:** Alternatively, when you do not want to change any ticket parameters (yet), select the ticket and click on  to **duplicate** it (and fill in a new name).

### Creating a Custom Ticket after Selecting a File

You can also create a custom ticket while you prepare to launch a task on a file:

1. Right-click your file(s), select **New Task** then **Other...**
2. In the **Select Ticket** dialog, select the **Default** ticket for the task you want to use.



**Note:** If you do not see any **Default** tickets, check your [Pilot Preferences](#).

3. Fill in the settings you want to use in the ticket.
4. Go to **File > Save As...** or use **Ctrl + Shift + S** (Windows) / **Shift + Command + S** (Mac).
5. In the **Save As** dialog:
  - a) Enter a name for this custom ticket.
  - b) Select if you want to add the ticket to your **Favorites**.
  - c) Select **Public** if you want to show this ticket to all Pilot users and/or if you want to use it from a browser client, from [Shuttle](#) or [from Esko editors](#).



**Note:**

- **Default** tickets and **Job** tickets can not be made **Public**.
- In the [Tickets view](#), Public tickets have a mark in the column '**Public**'.

## 4.7. Performing Basic Configuration

---

### 4.7.1. Creating Favorite Tickets

Tickets that you use a lot can be added to a list of **Favorites**. It then becomes easier to launch them, even with only one click.

Favorite tickets are linked to:

- the **User** logged into the Pilot. **Favorites** are personal.
- the file type. The favorite tickets you see or add are only those that match the file type you selected.

#### Creating a Favorite Ticket in the Files View

In the Files view, follow these steps to create a favorite ticket:

1. In the **Containers** or **Last used Job** mode, select a file (remember that you make favorites per file type).
2. Right-click in the **Launch Favorites** pane and choose **Add Favorite...**

When you have no favorites yet, click this dedicated link:

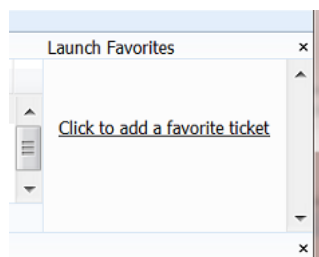

3. In the **Add Favorite** dialog, select the ticket you want to add as a favorite and click **OK**.

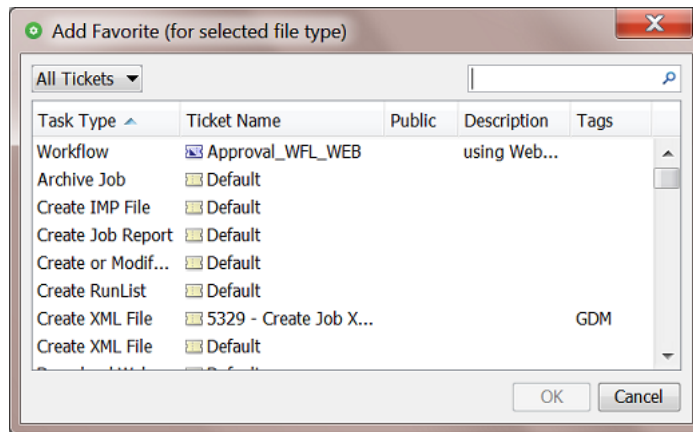

The drop-down list top-left offers to filter the list of tickets based on filters that you saved in the Tickets View. Learn about creating filters in [Smart Views](#) on page 138.



**Note:** This dialog only shows the (single and workflow) tickets suitable for the file type that you selected.

### Creating a Favorite Ticket in the Tickets View

In the Tickets view, you can either:

- Right-click your chosen ticket, select **Add to Favorites** and choose the group.
- When creating a ticket, select **Add to Favorites** in the **Save As** dialog.

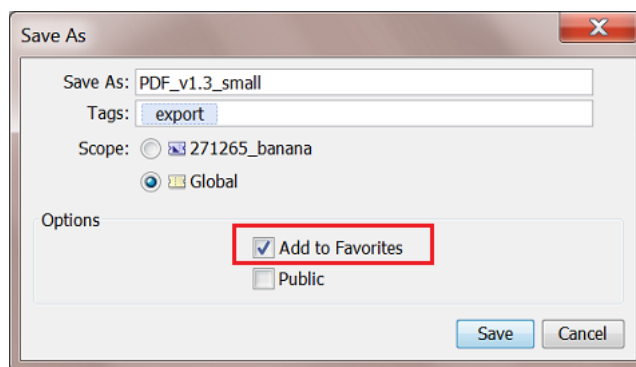

### Using a Favorite Ticket

In any Pilot view where you can make a selection, follow these steps to launch a task by using a favorite ticket:

1. Select the file(s) you want to launch a task on.  
The **Launch Favorites** pane shows all the favorite tickets for this file type.
2. Click the favorite ticket you want to use.



**Note:** If you want to use another ticket of the same task type (for example another **prepare for Viewer** ticket that is not a favorite), click the small arrow on the right side of the favorite ticket and select one from the list. This helps to avoid making too many favorites.

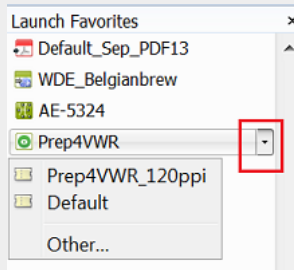

Mind that a ticket only appears in this list when it has already been launched at least once.

3. The ticket opens. If necessary, review or edit its parameters.
4. Click **Launch**.



**Attention:** If you do not want to open the ticket, but launch the task immediately, just press **Alt** when clicking the ticket.

Learn more in the chapter on [Workflows](#), where we describe extra features in the page [Organizing and Using Favorite Workflow Tickets](#).

## Organizing Favorites (Sorting and Grouping)

### Sorting

In your Files view, right-click the **Favorites** pane and select **Organize Favorites....** The resulting dialog shows the default group named '**Favorites**' and the tickets you already added.

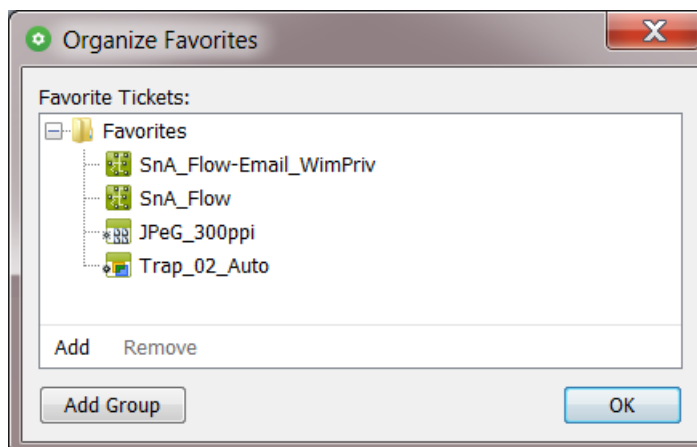

In this dialog, you can

- Sort them. Just make a selection and use drag-and-drop to define the order in which they appear.
- **Add** or **Remove** any favorites from this group.

You can even use SmartNames to define their name. Learn more in [Adding a Favorite based on a SmartName](#) on page 785.

### Grouping

Next the default group named 'Favorites', you can create your own groups.

Follow these steps:

1. In the **Organize Favorites** dialog: click **Add Group**, type in its name and click **OK**.

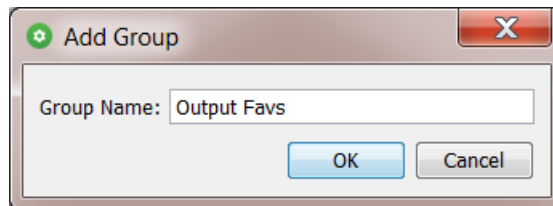

2. The new group appears in the **Organize Favorites** dialog.

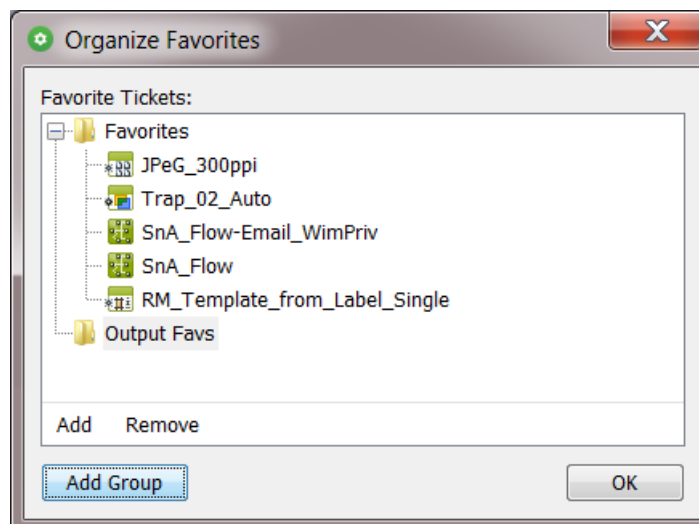

3. Select the group name and click **Add** to start adding favorite tickets.



**Attention:** If you do not do this right now, you will create an empty group when clicking **OK**. This will make the group disappear again.

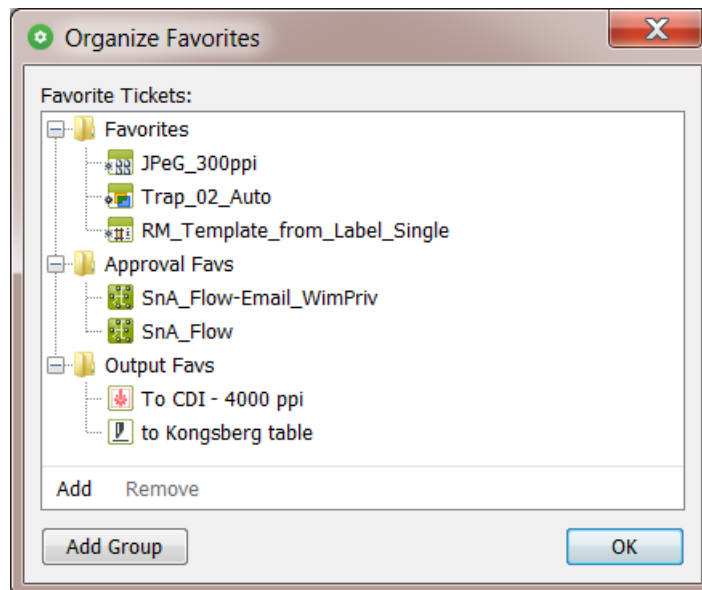

**Note:** You can also add a group by first making a selecting tickets:

- In the **Organize Favorites** dialog, select one or multiple tickets.
- Right-click and choose '**New group from selection**'.
- An '**Untitled Group**' appears. Rename it at wish.

4. Click **OK** to close.

You can drag-and-drop groups.

You can fold or un-fold groups.

You can drag-and-drop tickets from one group to another.

You can not create sub-groups.

Right-click the name of a group to **Rename** it or to **Remove** it (no confirmation is asked).



**Note:** All changes are immediately visualized in your Pilot. This includes whether the group's content is folded out or not.

Check the result in the Pilot's 'Favorites' pane. Don't forget that what you see there depends on your selection.

### 4.7.2. Creating Users (Introduction)

Managing Automation Engine **Users** is described in detail on the page about the [Users view](#) (part of the chapter [Pilot Views and Tools](#) on page 113).

### 4.7.3. Configuring RIPs or Proofer

To start making output for devices, you need to configure the related RIPs or proofers.

Automation Engine is optimized to work with Esko Imaging Engine and Esko FlexRip/Proof.

To configure an Imaging Engine RIP, learn more in [this page of the chapter "RIP'ing with Imaging Engine"](#). For FlexRip or FlexProof, see their item in the tool "[Configure](#)".

### 4.7.4. Pilot Preferences

Go to **Edit > Preferences** to define some Pilot preferences.

Pilot preferences are saved for the current user.

#### Tickets

- **Show default tickets:** Deselect this option to hide the default tickets in all lists that show tickets.



**Note:** This preference is only available if you have the [Access Right](#) 'Tickets: Show All Tickets and their Parameters (Public and other)'.

- **Use bold ticket names in task launching menu:** When choosing **New Task** or **Launch with**, select this if you want to see the ticket names for each shown task type in bold.

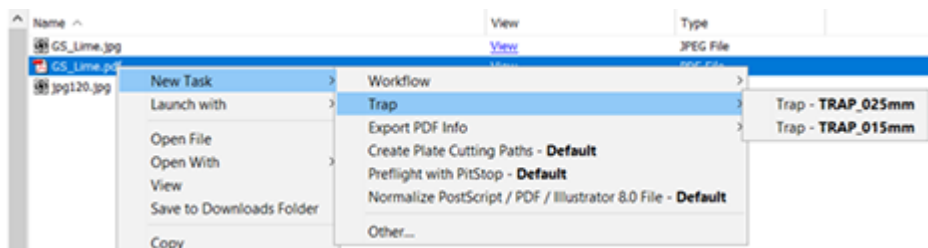

- **Open public parameter dialog:** When selected, opening a ticket will not open the full ticket dialog but show a dialog that only contains the ticket's [public parameters](#).

This is also (one of) the effect(s) when you do not have the [Access Right](#) 'Tickets: Show All Tickets and their Parameters (Public and other)'.

When administrators are building simplified ticket dialogs, being able to select and deselect this preference allows them to preview how the dialog will look for users who do not have that access right.



**Note:** This preference is only available if you have the [Access Right](#) 'Tickets: Show All Tickets and their Parameters (Public and other)'.



**Note:** Before v21, this option was named 'Show only Public Parameters in Tickets'.

- **When launching, do not open empty public parameter dialog:**

Select this when, at the moment you launch the ticket, you do not want to see a public parameter dialog when there are no public parameters.

- **When launching a favorite ticket:** These 2 shortcuts are always available but one of them changes its function depending on an above selected preference:

- **Alt-click: Launches task:** Holding the Alt key while clicking on a [favorite ticket](#) is the standard shortcut to launch that ticket without opening it.

- **Ctrl-click / Cmd-click:**

- When the preference **Open public parameter dialog** is selected, this shortcut opens the task launch dialog with all ticket options ("**Opens task launch dialog**").

- When the preference **Open public parameter dialog** is not selected, this shortcut opens the public parameter dialog ("**Opens public parameter dialog**"). This shortcut then overrules that preference.

This also serves the use case of an administrator that is preparing a set of tickets and their public parameters. This shortcut prevents that he even has to come back to this Preferences dialog and (de)select a preference just to check how the dialog will look to the regular user (who is only using public parameters).

## Units

- **Units:** Select the units you want to work with for **Dimension** (mm, cm, mil, inch, point), **Resolution** (ppi, ppmm, ppcm) and **Ruling** (lpi, lpmm, lpcm).
- Enter the number of **Decimals** you want the system to display.



**Note:** Changes that you make here are automatically adopted in the **Shuttle** and vice versa.

## Files

- **Preview Size (Info):** This defines the size of the preview in the **Info** (XMP) dialog (in pixels).
- **Open Normalized PDF files with:** This defines which application should become the default application when opening **Normalized PDF** files from within the Pilot. Learn about 'Normalization' in [Normalized PDF and XMP in Automation Engine](#) on page 44.

Normalized PDF files have a .PDF extension. The OS of your client computer will not make a distinction between Normalized PDF files and regular PDF files.

By default, PDF files will be opened by the OS with Adobe Acrobat Reader (when installed). However, when working with the Pilot, you may want to open Normalized PDF files in an Esko editor. Because making this distinction is not possible on OS level, you here have to specify which application you prefer to use. To do this, choose **Other** and **Browse** to the application's program file.

An example effect is that, if you double-click a PDF file in the Pilot, and it happens to be a Normalized PDF file, the application that you defined here will open that PDF.

This preference will be taken into account:

- in the **Files** view, when double-clicking the file or selecting **Open** from the pop-up menu
- in the **Tasks** view, when selecting **Open Output File** from the pop-up menu
- in the **To Do List**, when clicking a URL link to a PDF.



**Tip:** The Pilot also offers 'Open with', which allows you to select a non-default choice.

### Pilot

- **Number of recently used jobs in the job selector:**

Indicate how many you jobs you want to see in these drop-down lists (10 by default). Changes are applied when you sign back in to the Pilot.

- **When switching views, keep search criteria:**

Select this option when you want to keep the search criteria when switching to another View tab (of the same type of View).

### Jobs

#### Multi-Job Removal

Select your preferences when you remove multiple Jobs at once:

- **Remove Jobs even when they are in use by other users.**
- **Remove Jobs even when they contain unfinished tasks.**

## 4.7.5. Task Notifications

Each task ticket can trigger a **Notification**. The system will so notify someone by sending an E-mail when that task finishes in a specified state. A notification can also notify an external system by feeding it an XML or a TXT file with the same type of content.

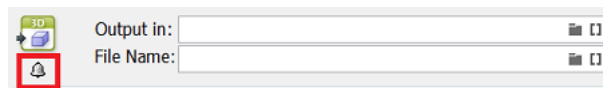

**Note:** In workflows, when your goal is to send an E-mail, consider using the separate task "Send E-mail" instead.



Learn more in the pages on [setting up Notifications in the Configure tool](#).

## 4.8. Using Public Parameters in Automation Engine

### Concept

Users often do not want or need to see all the parameters of a selected task ticket. You can make them see and define only the parameters that you decided to make **Public**. Seeing less options makes it simpler and helps reduce mistakes.

Ticket parameters that are made **Public** will be the only parameters visible to users when they want to launch tasks from:

- Automation Engine client applications: Pilot, Shuttle and browser client workspaces.
- Esko Editors connected to the Automation Engine server: ArtPro+, DeskPack (Adobe Illustrator) and the legacy editors ArtPro, PackEdge, Plato, FastImpose.



**Note:** Only *Public Tickets* can be launched from these client applications or editors.

For each **Public Parameter**, you can decide if the user can either:

- select a value from a list,
- enter a value himself.

### 4.8.1. Making a Parameter Public



**Note:**

- Not all ticket parameters can be made public.
- Parameters need to be made public before you start the workflow that their ticket is part of.

Open the ticket and follow these steps:

1. Right-click the parameter and select **Make Parameter Public**.
2. Right-click it again and select **Modify Public Parameter...**
3. In the **Modify Public Parameter** dialog that opens:
  - a) **Prompt as:** If you want, change the way the parameter will be called in the client application.
  - b) Choose either:
    - **Allow the user to set the value:** Select this if you want users to be able to freely enter a value.

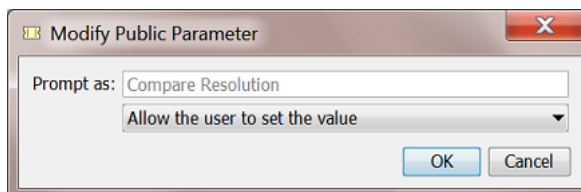

- **Let the user select a predefined value:** Select this if you want users to choose from a list of values that you define.

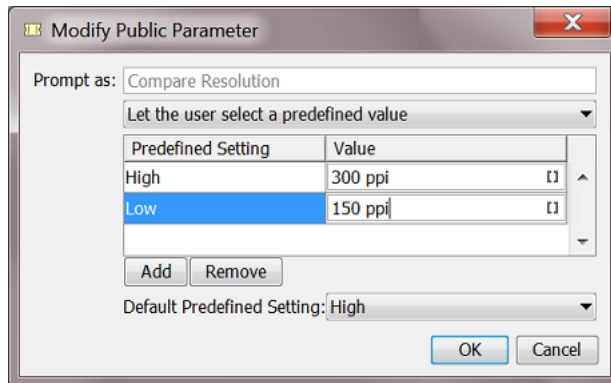

**Note:** Users will only see (and choose from) the **Predefined Settings**. They will not see the associated **Values**. So if they need to be aware of the value, just add it to the name of the setting.

In the above example, this is how the public parameter will look like to the users of the client application:

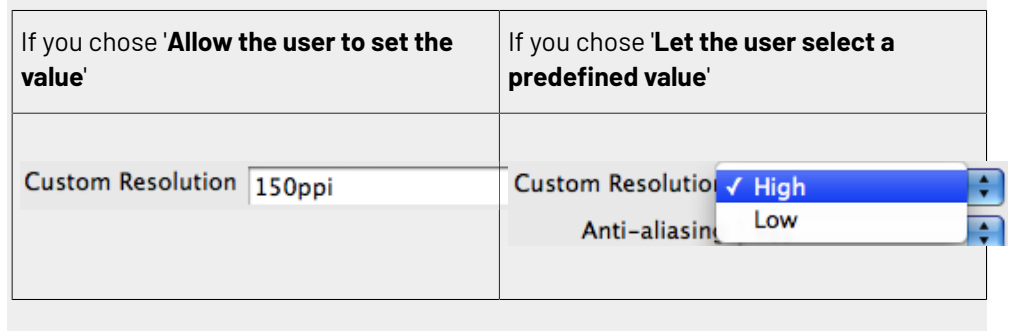

If, in the ticket, that parameter already offers a list of values to choose from, they will be displayed here.

**Default Predefined Setting:** You can here define the setting that will be used when the user didn't select another one.

4. Click **OK**.



**Important:** Settings related to public parameters are saved when you save the ticket.



**Important:** Don't forget to save the ticket itself as 'Public' as well.

## 4.8.2. Managing Public Parameters in a task Ticket

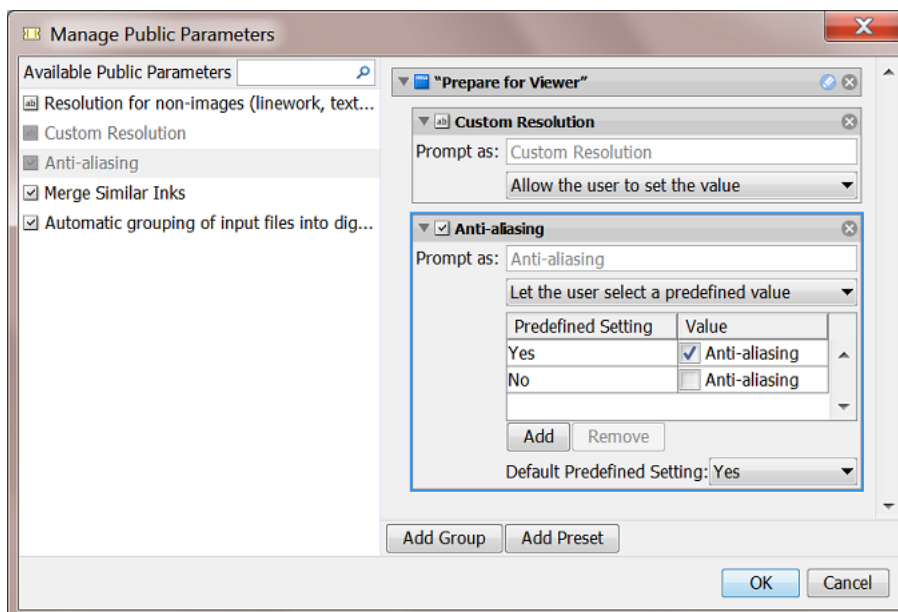

The **Manage Public Parameters...** dialog of a ticket is where you overview and manage its public parameters. In this dialog, your goal is to make it as simple as possible for the user that is asked to set these parameters.

1. In your ticket, go to **Advanced > Manage Public Parameters...**



The left pane shows all the parameters in this ticket that can be made public. The ones that were already made public are greyed out.

The right pane shows the public parameters and their settings.

2. You can:
  - drag parameters from left to right to make them public
  - click  if you don't want it to be public anymore
  - drag them up or down to rearrange the order that they will be shown to the user.
  - change public parameters' settings (**Prompt as**, **Predefined Settings**, etc.)
  - group public parameters under a custom header (click **Add Group**, click  to edit the header and drag parameters from the left). An example:

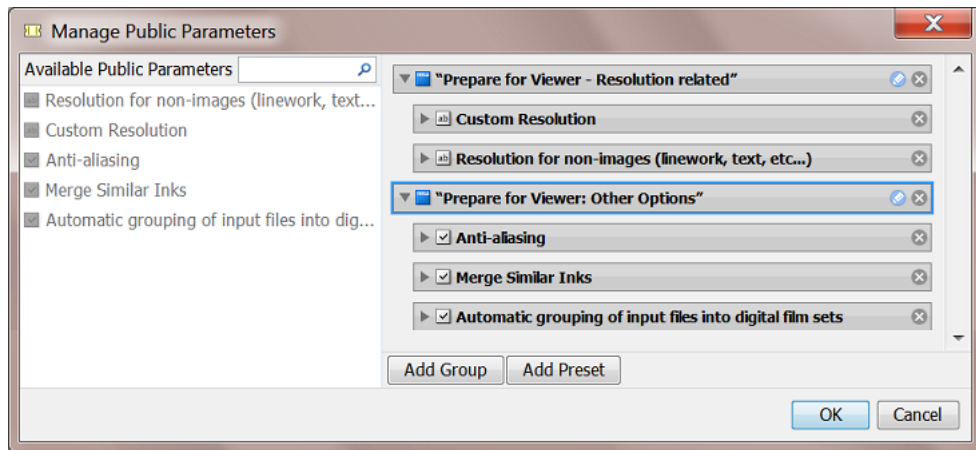

- use **Presets** to further simplify the users' choices (see [Making Presets to Simplify the Users' Choices](#) on page 102).

### Making Presets to Simplify the Users' Choices

**Presets** are customized combinations of parameters. They limit the amount of decisions that users have to make.

#### Example

Let's assume you want users to use different trapping settings when printing offset versus dry offset. You can collect those trapping settings in a **Preset**, so that users will only have to choose between 'offset' and 'dry offset'.

We start from a dialog of a workflow ticket where the trapping step has 3 public parameters:

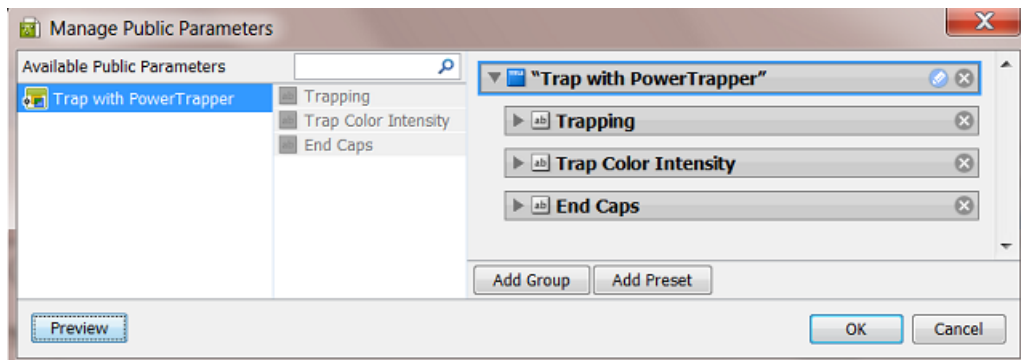

1. Click  to remove the (default) **Group** named "Trap with PowerTrapper"
2. Click **Add Group**.

A new "Untitled Group" is created. Click  to change its name.

3. Click **Add Preset**.

A new "Preset" is created. Click  to change its name.

By default, two example values will appear. The preset was renamed to 'Choosing Process to Decide Traps':

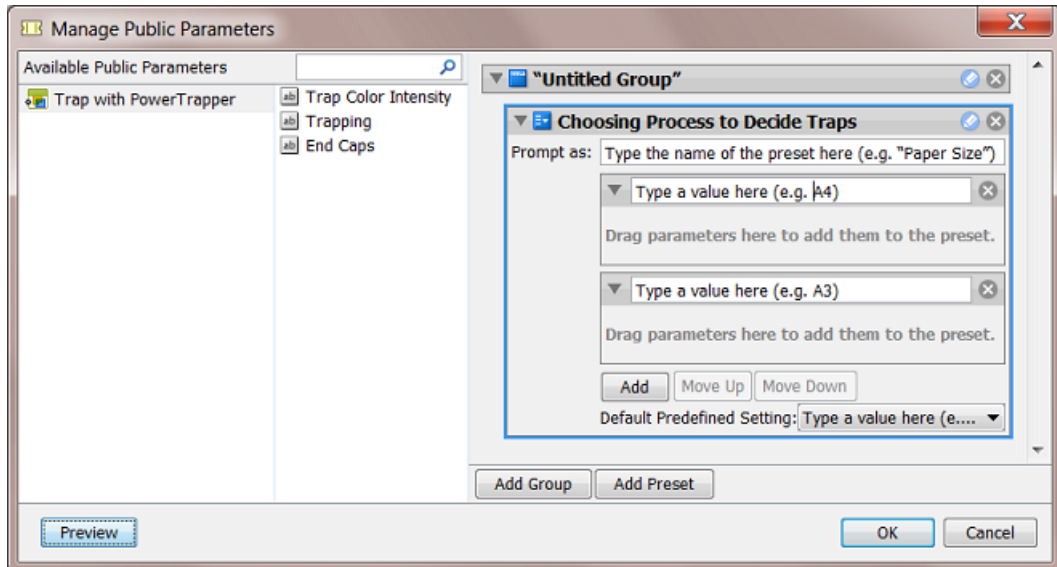

4. Define what the users will see:
  - a) in **Prompt as**, enter the text that users will see (replacing 'Type the name of the preset here (e.g. "Paper Size")')
  - b) enter the values that the users will choose from (replacing 'Type a value here (e.g. A4)'). In our example, we add 'Offset' and 'Dry Offset'.

Click **Add** if you want to add extra values (not the case in our example).
5. Drag the parameters from the dialog's middle pane onto one preset item. This will make them automatically appear under each preset item (here both under *Offset* and *Dry Offset*).

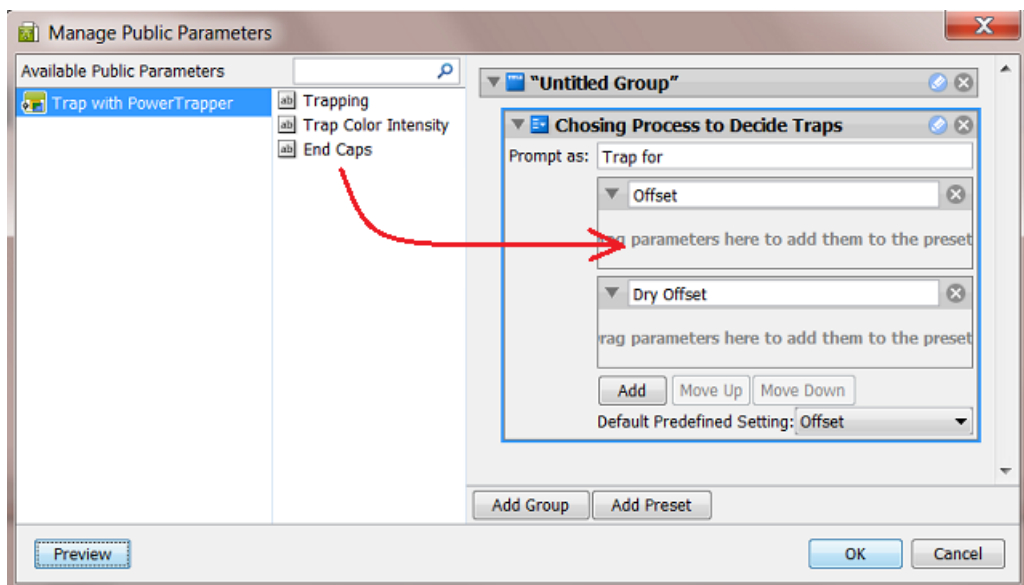

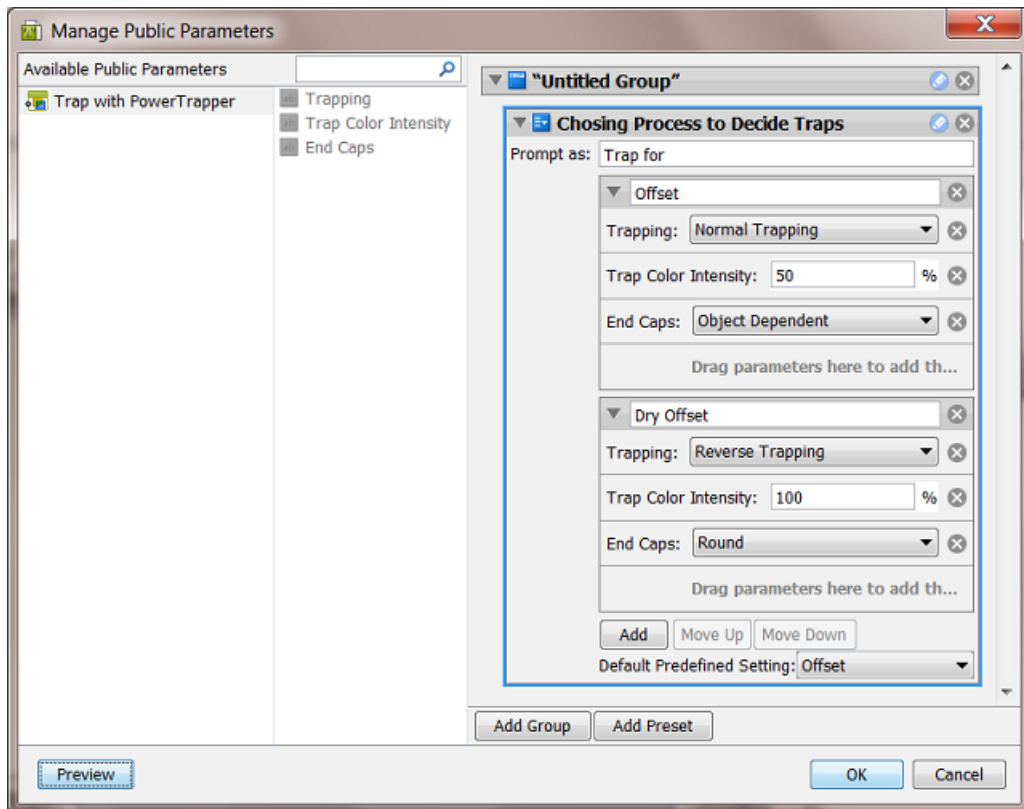

6. Define the parameters values for each preset item.  
See the above screenshot for a good example.
7. Use the buttons **Move Up / Down** to define the order of the **Presets** in the panel that the end-user will see.
8. Click **OK** to confirm and close the dialog.
9. Save your ticket to also save these public parameters.

This is how the resulting dialog will look like to the users of the client applications:

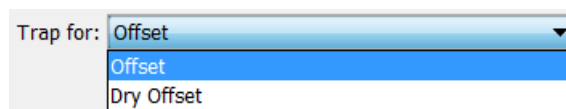

## 4.9. Uploading Files to Automation Engine

You can work with files that are already stored in your **Containers**, or with files that you (first) upload to Automation Engine.

Read below about several techniques to upload files. Some of those also immediately launch a workflow on the uploaded files.

### 4.9.1. Uploading Files using the Pilot

In the Pilot, in the **Container** mode or in the **Last used Job** mode, there are two ways to manually upload files:

- Drag and drop files or folders from outside the Pilot onto a folder in the Pilot. Or use copy/paste shortcuts.
- Right-click your destination folder or go to **File > Upload Files....** In the dialog that opens, browse to your files or folders and click **Upload**.

#### About multiple uploads and cancelling uploads

When the upload is not immediately finished, an **Upload** window appears and you can continue working with the Pilot. You can upload multiple sets of files. When other files are still uploading, they will be added to this **Upload** window.

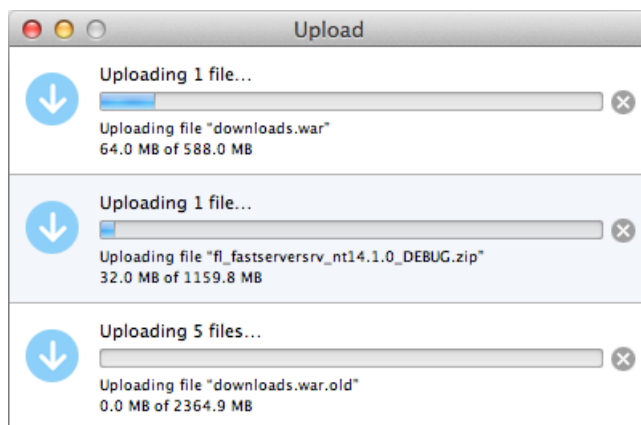

All uploads can be canceled individually. Click  to stop the upload immediately. Any partially uploaded files will be deleted.

When all uploads are done, the **Upload** window automatically closes.

### 4.9.2. Uploading Files from an FTP Server

1. In **Containers** mode or in **Last used Job** mode, right-click the folder in which you want to upload your file, and select **Upload Files from FTP Site....**  
This opens the **Upload from FTP Site** dialog, where you first need to enter the settings for the FTP connection:

2. In **Host**, enter the name of the FTP server that hosts your files.



**Tip:** To use a port other than the default port, add ' :' and the port number after the host name. For example: myftpserver:1085

3. Enter a **User Name** and **Password** that corresponds to an account on the FTP server.

4. In **File Transfer**, choose between **Binary** and **ASCII**.

**Binary** will always work, but if you have an ASCII file, the transfer will go a bit faster when selecting **ASCII**.

5. By default, the transfer uses Active **Connection Mode** (where the FTP server opens the data connection).

If your system is behind a firewall that blocks incoming FTP server connections, select **Passive** to use Passive Connection Mode (where the client initiates the connection).

6. Select **Secure FTP** if you are connecting to a secure FTP server (over FTPS, not SSL or SSH).



**Tip:** If you are experiencing problems using secure FTP, try connecting over regular FTP, and ask your IT administrator to check the security settings of your FTP server.

7. **Options:** A field for one or more exceptional options, formatted as key-value pairs. For example: When you experience problems when interfacing to a Rumpus FTP Server, add `systemKey=UNIX` in this field and try again.

8. Select '**Remove remote data after transfer**' if you want to delete the files from the FTP site once they are uploaded to Automation Engine.



This enables the option to '**Backup remote data before removal**'. When selected, indicate the **Backup Folder** where the files should be copied.

9. When you are done, click **Connect** to establish the connection.
10. Click **Upload** to start the file transfer.

### 4.9.3. Using Access Points to Upload Files

**Access Points** are documented [here](#) in the dedicated chapter *Integrating with External Systems* on page 1769.

### 4.9.4. Using Shuttle to Upload and Process Files

You can upload and immediately process files from any Mac or Windows client computer using the **Shuttle** tool.

Learn more in the chapter *Working with Shuttle* on page 875.

## 4.10. Launching Tasks from Editors

---

### 4.10.1. Setup Requirements

For Esko editors and DeskPack (Adobe Illustrator) to be able to connect to an Automation Engine server, the "**Shuttle Server**" component needs to be running. Learn more on [this page of the Configuration tool](#).

In the **Preferences** menu of the editor, you also need to define which Automation Engine server you want to connect to.

### 4.10.2. Launching Tasks from ArtPro+

Launch a task from ArtPro+ is described in the chapter *Workflows*, in the page on [Launching a Workflow with Public Parameters](#) on page 856.

### 4.10.3. Launching Tasks from Adobe Illustrator (the Shuttle Plug-in)



**Note:** To launch tasks from Adobe Illustrator, you need to install the **Shuttle Plug-in**. Download it from <https://mysoftware.esko.com/>.

Follow these steps to launch a task or workflow on the file that you have open in Illustrator (and in front of any other open files):

1. Go to **File > Launch Workflow...** or use **Option + CMD + Z**.

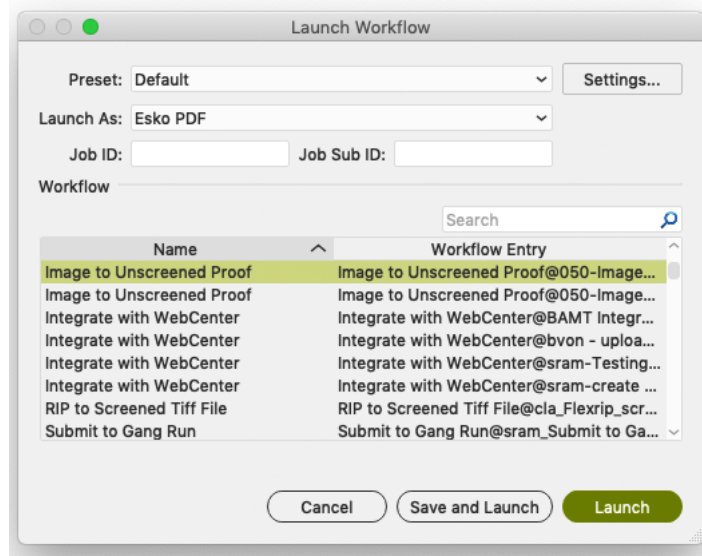

2. In **Launch As**, choose **Esko PDF** to copy a Normalized PDF or PDF+ version of your file onto the **DeskPack Container**. Choose **Adobe PDF** to copy the Adobe Illustrator PDF version.
  - **'Esko PDF'** uses the 'PDF Export' plug-in to convert your Illustrator file to either Normalized PDF or PDF+, depending on the setting in Ink Manager. To refine the conversion, you can select one of the PDF Export **Presets**, or click **Settings...** and edit the **PDF Export Settings**. These changes are not saved.
  - **'Adobe PDF'** uses the Adobe PDF preset 'Illustrator Default'.



**Note:** 'Color Conversion' and 'Profile Inclusion Policy' are not part of the preset 'Illustrator Default', but **Launch Workflow** will apply color conversion with the last settings used.

3. If you want to link your file to an existing Automation Engine Job, fill in an existing **Job ID** and/or **Job Sub ID**. The task on the Normalized PDF will then run in that Job context, which means it can use the [Job Setup parameters](#) when SmartNames refer to them in the selected workflow..



**Note:** If your open file is already saved in an Automation Engine Job folder, the **Job ID** and/or **Job Sub ID** will be filled automatically.

4. Select the task or workflow you want. If it has public parameters, fill them in.
5. Click **Launch**. If your file was changed since the last save, you can click **Save and Launch** to first save your document and then launch the task.

#### 4.10.4. Launching Tasks from ArtPro

In **Preferences > Servers > Shuttle**, add the name of your Automation Engine server.



**Note:** In that same dialog, the tab **Automation Engine** serves to define other preferences related to that server. You do not need to fill that one in when you only need this connection to the "Shuttle Server".

1. To launch a workflow on the currently open file, go to **File > Launch Workflow...**

This opens the **Launch Workflow** dialog.

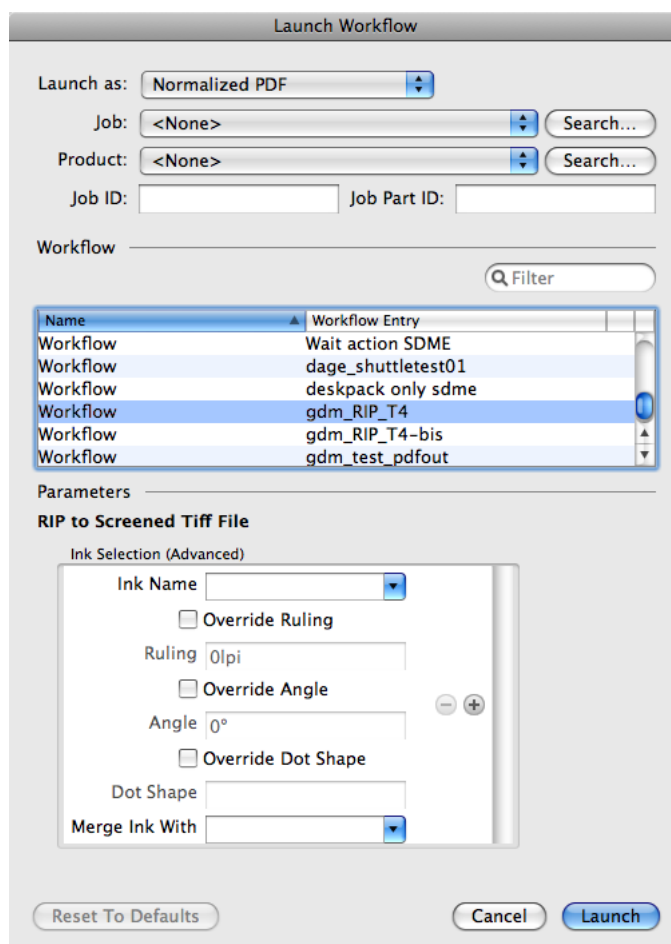

2. **Launch as:** Your open file is an ArtPro file, but you can choose as which file type you will send it to the selected workflow.

If your workflow is...	you can launch the file as...	with...
an Automation Engine workflow accepting Normalized PDF files as input,	Normalized PDF	either <b>Normalized PDF</b> or <b>Normalized PDF (embedded)</b> .
an Automation Engine workflow accepting PDF files as input,	PDF	any of the available PDF flavors.

If your workflow is...	you can launch the file as...	with...
an Automation Engine workflow accepting ArtPro files as input,	ArtPro	with the included images (TIFF, EPS...) or without (then only the ArtPro file and any ArtPro CT file).

- If you want to add your file to the **Job Folder** of an Automation Engine Job, select it from the **Job** list or fill in its **Job ID** and/or **Job Part ID**.



**Note:** Use the **Search...** button to see a list of active Jobs, including some of their metadata.

- If you want to add your file to an Automation Engine **Product**, select it from the **Products** list or fill in the **Product ID** and/or **Product Part ID**.



**Note:** Use the **Search...** button to see a list of your server's **Products**.

- Select the workflow you want to launch.
- Fill in any of its **Public Parameters**.  
If you want to go back to the default parameters values after changing them, click '**Reset To Defaults**'.
- Click **Launch**.

### 4.10.5. Launching Tasks from PackEdge or Plato



**Attention:** Before you can launch a task on it from within PackEdge or Plato, you must save your file on an Automation Engine **Container**.

- Go to **File > Launch Workflow...**

The dialog lists all public tickets. When selected, a ticket shows its [Public Parameters](#).

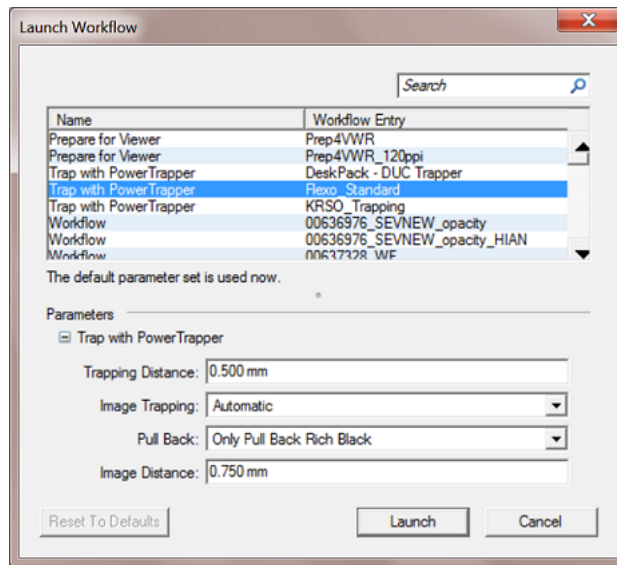



**Tip:** When you expect tickets to show up here but none do, check if the [Shuttle server is running](#).

2. Select the task or workflow you want. If it has public parameters, fill them in.
3. Click **Launch** to launch that workflow on your open file.

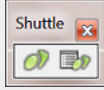

**Tip:** To access this "Shuttle Server" easily in the future (without using the menus):

1.  Go to **Window > Toolbars > Shuttle** to open the Shuttle palette.
2. Drag it into your application's toolbar.
3. Click  to open the **Launch Workflow** window. Click  to open the **Shuttle** window where you can monitor and manage the launched tasks.

### 4.10.6. Launching Tasks from FastImpose

When working with **FastImpose** Server, you must save your file on an Automation Engine Container before you can launch a task or workflow.

1. Go to **File > Launch Workflow...**
2. Choose what file type you want to launch your file as.
  - When working with FastImpose Server, you can only launch your file as an IMP file.
  - When working with FastImpose Standalone, you can launch your file either as a JDF or a PDF file.

Click the **Settings...** button to set **JDF** or **PDF Export Preferences**. Learn more in the [FastImpose documentation](#).

3. Select the workflow you want. If it has public parameters, fill them in.
4. Click **Launch** to launch the workflow on your file.

## 5. Pilot Views and Tools

---



**Note:** Learn about the Automation Engine browser client in the chapter [Browser Client Workspaces](#) on page 886.

### 5.1. Concepts and Overview

---

#### Concept

The Pilot's **Views** offer different functionality or a specific mode to work in. Find an overview below with a short description.

At the end of this chapter, we also describe the [Tools](#). Tools are views or dialogs that you can open in a separate window, next to your Pilot. Most of these are also available as a View.

#### Automatic Hiding of Views

Depending on the **View Mode** you are using (**Containers**, **Job Overview** or **Last used Job**), you will have access to different views.

Depending on your [access rights](#), you may not be able to see some of the views.

#### Manually Selecting Views

Right-click a view and choose **Remove from Views bar**. To enable that view again later, right-click anywhere in the Views panel, choose **Select Views...** and select the one(s) you want. This selection is saved per user and remembered the next time you log in to the Pilot.

#### Overview per Category

##### • General

- The **Files** view offers a view on the files in your Containers or Jobs. You typically use it to open or view them and to launch workflows on them. Learn more in [The Files View](#) on page 115.
- The **Jobs** view is only visible in **Job Overview** mode. It lists all or a filtered list of your Automation Engine Jobs database. Learn more in [The Jobs Views](#) on page 540.
- The **Inactive Jobs** view shows Jobs that were moved to a cheaper storage solution. It is only available customers of a SaaS setup and requires an Esko Cloud account. Learn more in the chapter about [AE SaaS](#).
- The **To Do List** view lists all actions that need user intervention. Learn more in [The To Do List View](#).
- The **Products** view shows the items in your Products database. This concept is useful when you manage re-prints. Products represent production data that you temporarily link to a Job order.

It is the Job order that has the specifications how to output the product this time, possibly together with many other Product items.

Products are what you keep long term, until you are sure you will not have to produce them again. Jobs however are 'WIP' (Work In Progress), temporary by definition. A Job should be removed when it is finished. Learn more in the dedicated chapter [Products](#) on page 594.



**Note:** The view is 'Products on Esko Cloud' is only available for AE SaaS setups.

- The **WebCenter** view enables Pilot users to see what documents are inside a WebCenter project without having to open a browser. Learn more in the chapter on [Integrating with WebCenter](#) on page 1741, in its section [The WebCenter View in Automation Engine Pilot](#) on page 1744.
- The **Tasks** view shows all or a filtered list of tasks. It shows their status and offers easy access to log files or input or output files. You can here also relaunch them, with or without opening and changing settings first. You have to clean up this list. Learn more in [The Tasks View](#) on page 125.
- The **Milestones** view shows the milestones of the selected Job (in **Last used job** mode), or those of all Jobs (in **Job Overview** mode). Learn more in [Milestones: Tracking Job Status](#) on page 568.
- The **SmartNames** view allows to manage SmartNames. Learn more in [The SmartNames View](#) on page 641.
- The **Tickets** view allows to manage tickets. Learn more in [The Tickets View](#) on page 129.

- **Commercial Print**

These views only serve page imposition workflows:

- The **Pages** view shows a page list and details about the page status in its impositions.
- The **Proofs** view shows the sets of imposition proofs and their status.
- The **Plates** view shows details about all (offset) plates required for that Job.

Learn more in the dedicated document on "Commercial Print (Imposition) workflows in Automation Engine". Find it next to the "Complete Manual" of version AE **18.1** on <https://www.esko.com/en/Support/Product?id=Automation%20Engine&ver=18.1>.

- **Sign and Display**

These views are described in the dedicated chapter on [Sign & Display Workflow](#) on page 953.

- The **Orders** view shows an overview of what was ordered to be printed on (flat bed or roll fed) digital printers. Learn more in [The Orders View](#) on page 1044.
- The **Gang Run Printing** view shows the substrate queues where submitted graphics wait to be nested on your available sheet or roll substrates. Learn more in [The Gang Run Printing View](#) on page 984.

- **Flexo CTP**

These views are described in the dedicated chapter on [Flexo CTP Workflow](#). Find their short description in [Introducing Flexo CTP Device related Views and Tasks](#) on page 1487.

- **Press Plate Sets.**
- **Press Plates.**



- **Plate Merger.**
- **Merged Plates.**
- **CTP Queues.**
- **Cutting Tables**

These views are described in *Kongsberg related Views*, a section of the dedicated chapter on [using Automation Engine to cut jobs on a Kongsberg table](#).

- **Sheets.**
- **Table Queues.**
- **Smart Views**

Smart Views are custom filters that you saved as a View. Learn more in [Smart Views](#) on page 138.

- **Setup**

These views serve to set up your configuration.

- The **Devices** view lists all output devices connected to your Automation Engine server. You can see their status and workload. These devices can be [CDI Imagers](#) or [Kongsberg Tables](#).
- The **FlexRips** view gives an overview of the "Esko Link" queues to your FlexRip Dispatchers. Learn more [here](#).
- The [Queue Monitor](#) view.
- The [Containers](#) view.
- The [Access Points](#) view.
- The [Customers](#) view.
- The [Order Materials](#) view.
- **Accounts**
  - The [Users](#) view.
  - The [Groups](#) view.
  - The [Roles](#) view.

## 5.2. General Views

---

The views in this category can be used in most types of work.

### 5.2.1. The Files View

This view is available in **Containers** and in **Last used Job** mode.

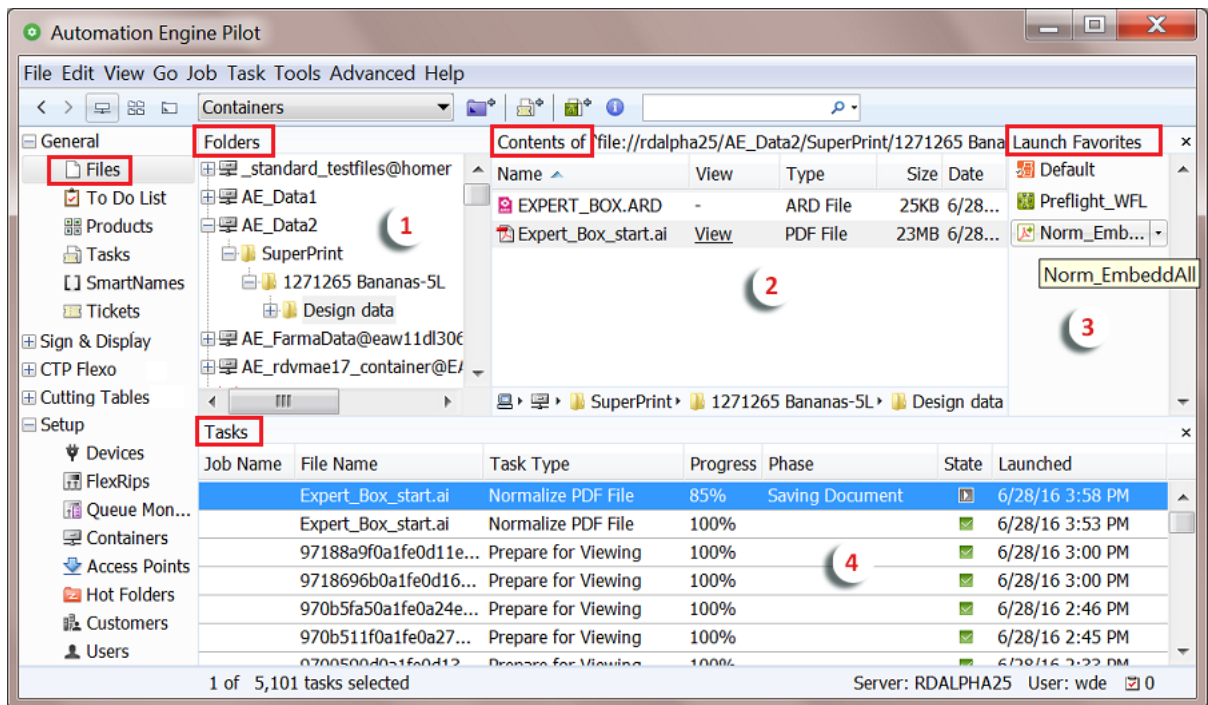

1. The **Folders** pane shows your *Containers*, folders and job folders (in **Containers** mode) or a job folder and its subfolders (in **Job** mode).



**Note:** When working with Automation Engine Jobs, you typically don't use this view but use the **Last used Job** mode to see only the data of the Job you are working on.



**Tip:** Instead of browsing to a folder, you can also choose the function **Go To Path** (find it in the **Go** menu). This is useful to paste a URL or UNC path that you copied from somewhere. You can type the path manually as well. You can even use the function ('Shift-')Tab to be presented a next folder.

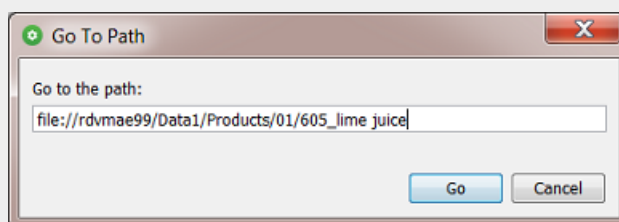

Examples of supported paths:

- `file://BigServer/Data1/Products/BeerVille/Devil_33.ap`
- `\\BigServer\Data1\Products\BeerVille\120381 Proof.pdf`
- `smb://BigServer/Data1/Products/BeerVille/4545_report.pdf`

2. The **Contents** pane shows the contents of the folder you selected in the **Folders** pane.



**Note:** Every time the Pilot shows you the contents of a folder, it automatically checks the file types of all files in that folder and shows the result in the column **"Type"**. This means that the file's extension is less important here. For example a file with an extension .AI initially shows as an "Adobe Illustrator" file but when the file type detection found that it is PDF compatible, it will show as type "PDF File".

After having selected one or multiple files or folders, a lot of typical file management is possible via the **File** menu or via a right-click. Functionality on a multiple selection can be more limited. Classic shortcuts for cut/copy/paste are also present.

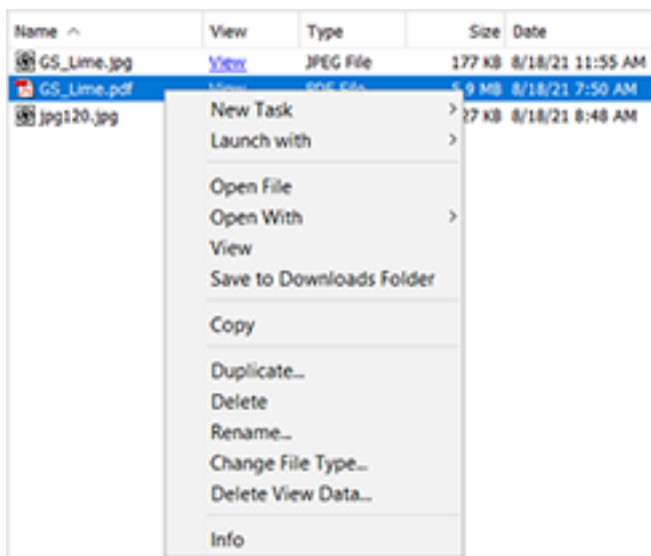

- **New Task** and **Launch with**: Learn more in [First Steps in Launching Tasks](#) on page 87.
- **Open File**: This has the same result as if you double click the file on your local client: it will open in the default application for that file type (according your local OS).
- **Open With**: Opens a dialog where you can register local applications. The next time you select 'Open with', you will then be offered a list of the registered applications for that file type.
- **View**: Opens your file in the Automation Engine Viewer. Learn more in [Automation Engine Viewer](#) on page 1077.
- **Save to Downloads Folder**: Saves a copy of the selected file(s) in the 'Downloads' folder of your local client (Windows or Mac OS). This feature was designed for users of an AE SaaS setup but can be used by others as well.
- **Copy**: Adds a copy of your selection to your clipboard.
- **Duplicate...**: Makes a duplicate of your selection in that same folder. You will be asked how the new data should be named. This function is not enabled when you selected multiple folders.
- **Delete**: Deletes the selected files or folders. You will be asked to confirm. There is no 'undo' possible afterwards.
- **Rename...**: Opens a dialog asking you to define the new name (for every selected item).

- **Change File Type...:** Use this when you want to overrule the file type that was *discovered automatically*. Changing the file type will make the Pilot offer different task types to be launched on that file.
- **Delete View Data...:** Learn about prepared View Data in *Automation Engine Viewer* on page 1077.
- **Compare:** When having made a selection of more than one file, this will open the AE Viewer in a browser and compare those files.



**Restriction:** This function is only enabled when the selected files will be compared using the latest viewing technology. Learn more in *Several Viewing Technologies* on page 1080.

- **Use Selection for Compare:** This makes it possible to compare files that are not in the same folder. You then first select the first file, right-click and select this option. You then go to a different folder/Job/Product, select a second file, right-click and choose 'Compare'.
- **Info:** Opens the **Info** dialog that shows the metadata of your selection. Learn more in *PDF+ File's Info Dialog* on page 57.
- **Summary:** When you selected more than one file, you can choose between **Info** and **Summary**. Summary will open only one dialog. Info will open a dialog for each selected file.



**Tip:** When you selected many files, you can also start with a Summary and from within that dialog ask more **Info...** on a specific item.

3. The **Launch Favorites** pane allows you to add your favorite tickets and allows to launch them with one click. Learn more in *Creating Favorite Tickets* on page 91.
4. The **Tasks** pane shows all launched tasks (in **Job** mode, only those for that job). Right-clicking a task offers functionality to delete, open, relaunch etc... Learn more on the page on the separate *Tasks View*.

## 5.2.2. The Shared Files View

This view shows the files of the selected job that were uploaded to its shared job folder to Esko Cloud. Learn more in the chapter *Sharing to Collaborate with other AE servers* on page 1685. Find a direct link [here](#).

## 5.2.3. The To Do List View

The **To Do List** is where you manage all actions that need user intervention. A user intervention is typically a step in an automated workflow where you require a human decision or action.

This view shows several types of actions:

- **Message:** When created in this view, via . Learn more [here](#).
- **Checkpoint:** When created by a *Wait for Action (Checkpoint) task*.
- **Milestone Action:** When created by *the Manage Milestone task*.

Use the **To Do List** to view, modify, forward or delete these actions.

This view can also be opened as a separate window:

- Go to **Tools > To Do List**.
- In the Pilot's bottom **Status bar**, click on the **To Do List** icon:

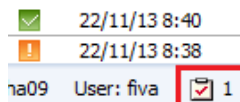

### Seeing To-Dos in your Mac 'Notification Center'

To-dos can also appear in the macOS X notification center. You can there click on 'show' to open that item in the Pilot.

To enable or disable this, go to 'Apple' menu > System Preferences, then click Notifications. You may there see 2 Pilots: an Oracle version and a 1.6 java version. Of the Pilot app that shows the number of to-do items, switch that 'numbers' icon on or off.



**Note:** Mind these requirements:

- You will only see those on your Mac when the Pilot is not the front-most application on that computer.
- You need to be logged in to that Pilot.

### Checking To-Dos

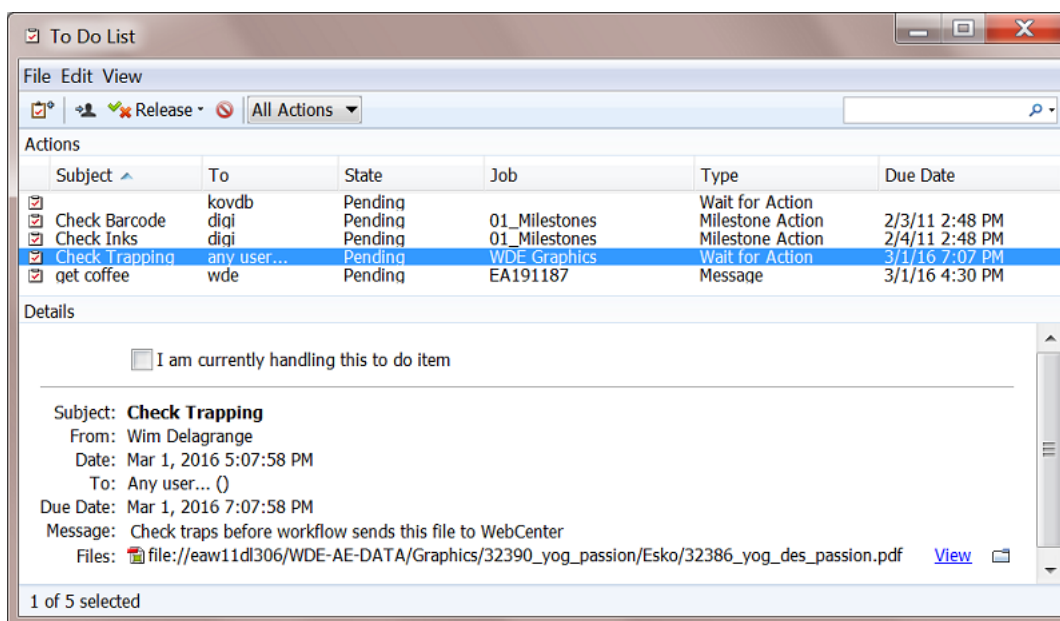

As in all views, click the header of a column to sort or show / hide columns.

### Filtering

The **Actions** panel shows all actions when in Container mode or only those of the selected Job.

You can filter the list by using the search field. Learn more in [Using Filters and Creating Smart Views](#) on page 140. When you opened the To Do List as a separate window, the filters you saved also appear in the drop-down menu.

When using the To Do List as a View, a number is shown to illustrate how many of the actions are assigned to the user logged in and also those assigned to 'any user . . .'. In Job view, this is limited to the actions in that Job.

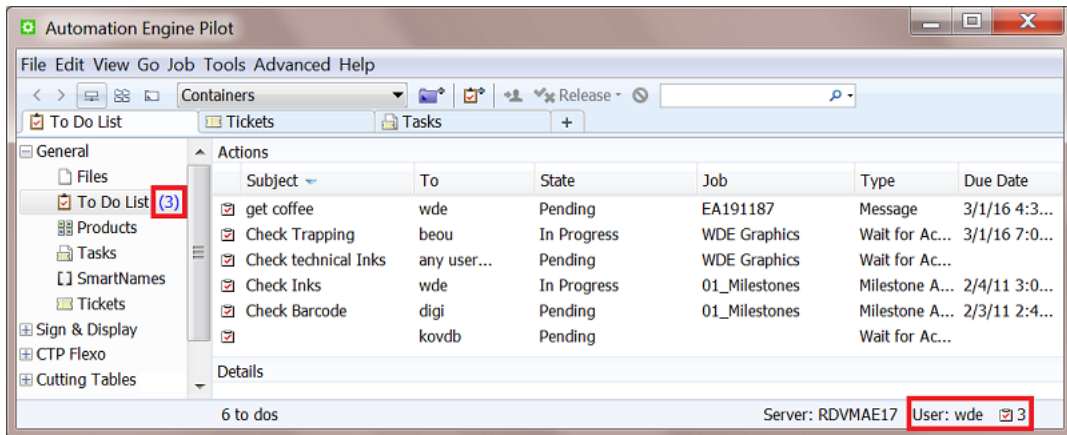

### Details

Select an action to see all its **Details** shown in the panel below.

Double click the action to open it and also see when and which user created it.

### Handling a To-Do

To handle a to-do (any type of action in the To Do List), select it in the list and use the available menu or buttons or right-click to discover the functionality.

The **Details** pane shows the details of the selected action. Alternatively, double click the action in the above list to open it in a separate dialog.

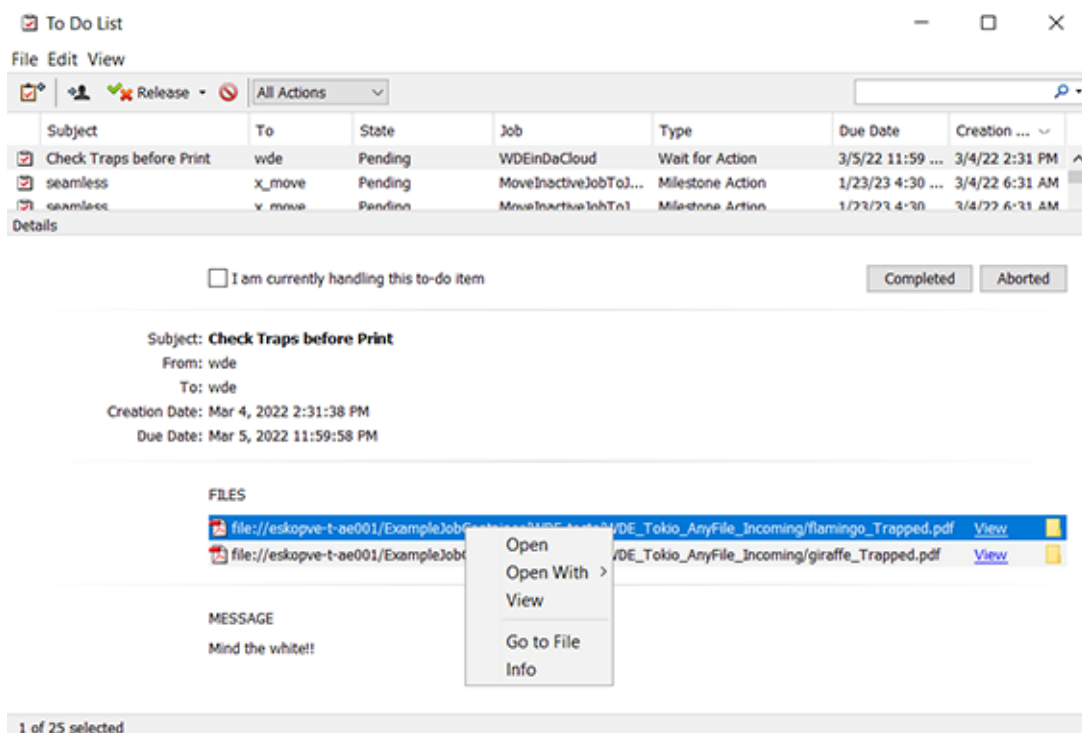

Possible actions in the list itself:

- To forward one or more actions to another user, select them, click and select the other user. Before confirming you can change the **Subject**, **Due Date**, **State** or **Message**.
- In the list, right-click an action and choose **Go to Job** to open the Job this action relates to. Alternatively, use **Ctrl/Cmd + Alt + O**.
- To release the action to one of the output states offered by the **Wait for Action (Checkpoint)** task that created it, right-click or click and choose the wanted output state (by default **Completed** or **Aborted**). Learn more in [The Wait for Action \(Checkpoint\) Task](#) on page 752.
- To delete actions from the To Do list, select them and click or press **Delete**. You will be asked to confirm.

Possible actions in an action's **Details** pane:

- Select **I am currently handling this to-do item** to change its state to **In Progress** and, when not already so, assign the item to yourself.
- **Completed - Aborted**: In the same way as described above, you can also decide the output state here
- Next fields are information only: **Subject**, **From**, **To**, **Creation Date** and **Due Date**. Learn more in [Creating a To-Do Message](#) on page 122.
- **FILES**: Find a link to each input file of the [Checkpoint task](#) that created this action. Right-click one or multiple links to see the possible actions:
  - **Open**: Opens the file in the local application associated with this file type. Alternatively, double click the link.
  - **Open With**: Select a local application that you registered for this file type.

- **View:** This opens the file in the [Viewer](#). Alternatively, click **View** next to the file path..
- **Go to File:** This opens the file's folder in your local 'Explore' application. Alternatively, click on the folder icon next to the file path.
- **Info:** Opens the file's Info dialog.
- **MESSAGE:** The optional message that was added in the [Checkpoint task](#) (or by a previous user that forwarded the action).

### Creating a To-Do Message

To create a to-do action of the type **Message**:

1. Click  in the tool bar.
2. In the **New Action** dialog that opens:
  - a) Enter a **Subject**.
  - b) Choose who to assign the action **To**. (mandatory field)
  - c) Relate this action to a **Job** if needed.
  - d) Choose a **Due Date**.
  - e) Choose the to-do **State**.
  - f) Enter a **Message** if you want.

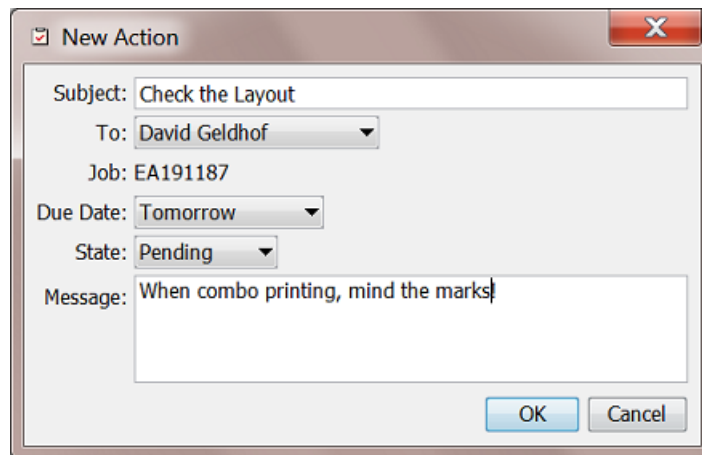

3. Click **OK** to confirm.

### 5.2.4. The Products View

This view is available in **Containers** and in **Job** mode.

The **Products** view is a user friendly, searchable view on the Products database. You can use it to create new Products, search them and link them to Jobs.

You can see the Products in a thumbnail view  or a list view .



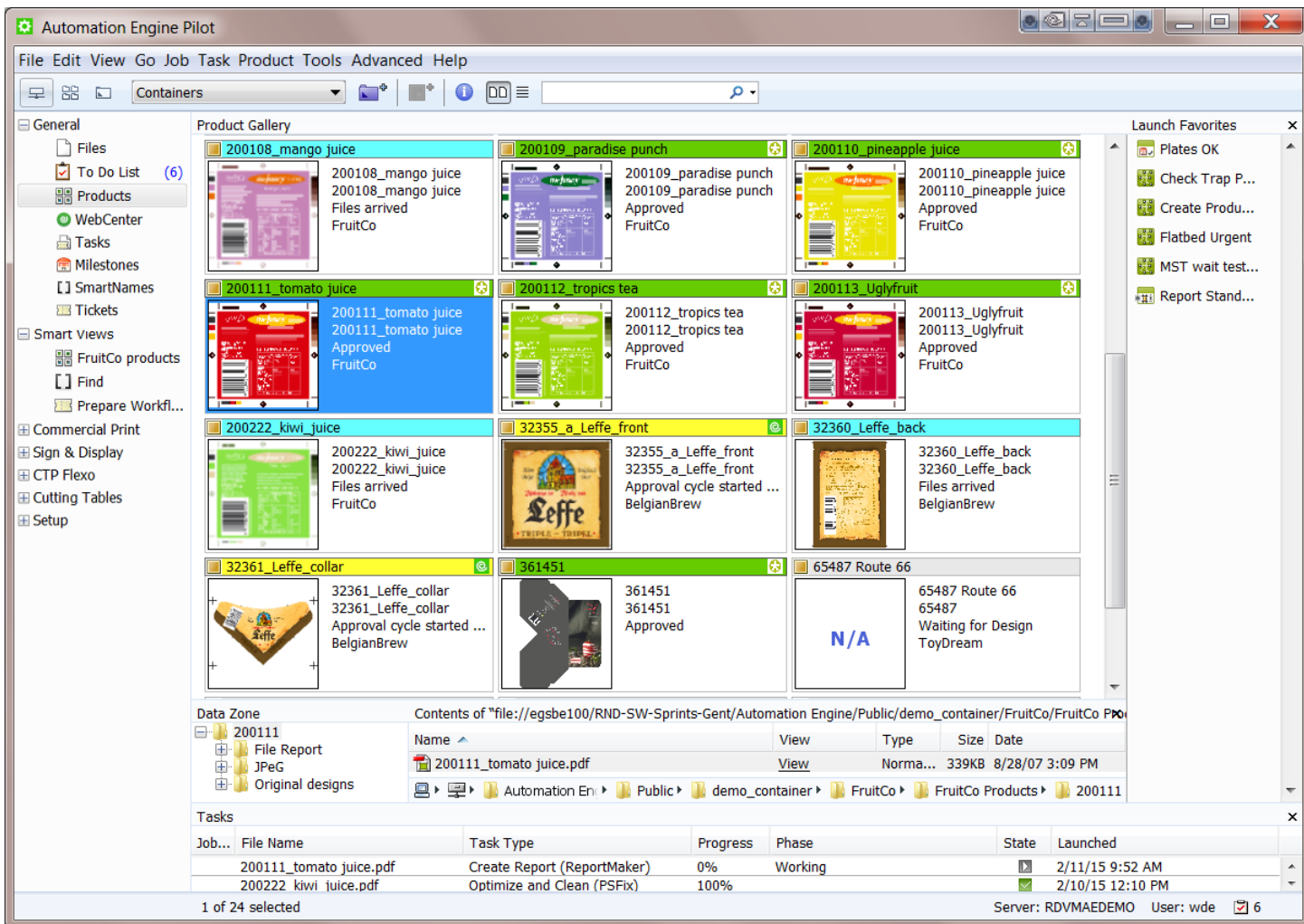

Working with Products is documented in the dedicated chapter [Products](#) on page 594.

### The Products on Esko Cloud View (SaaS only)

This view is only available for [AE SaaS server setups](#).

Learn more in [Storing Products on Esko Cloud](#) on page 1658.

## 5.2.5. The WebCenter View

This view is only available in **Last used Job** mode.

Files that have been published on WebCenter (with the [Publish on Web task](#) or the [Publish imposition on WebCenter Chain task](#)) will appear in the WebCenter View. Pilot users can so, without having to open a browser, see which documents are inside a WebCenter project and what their status is.



**Attention:**

- First you need to configure connections to WebCenter sites that you want to use in tasks, for example in the [Publish on WebCenter task](#). Learn more in [Configuring WebCenter sites](#).
- Then, when accessing this WebCenter View for the first time, the View will request you to fill in a default configuration for this View (similar as one of those you added in the Configure tool). Click **Save to Configuration** and click **Show Documents** to check if the connection works.
- When you want to change this configuration later, right-click in an empty area of this view and choose **Configure**.

The View also shows the status of the WebCenter documents.

- When a file arrives on the WebCenter site and approval is required, its status will be **pending**.
- Files that do not require approval are marked with **approval is not required**.
- After a file is approved or rejected in WebCenter, its status automatically updates in this WebCenter View.

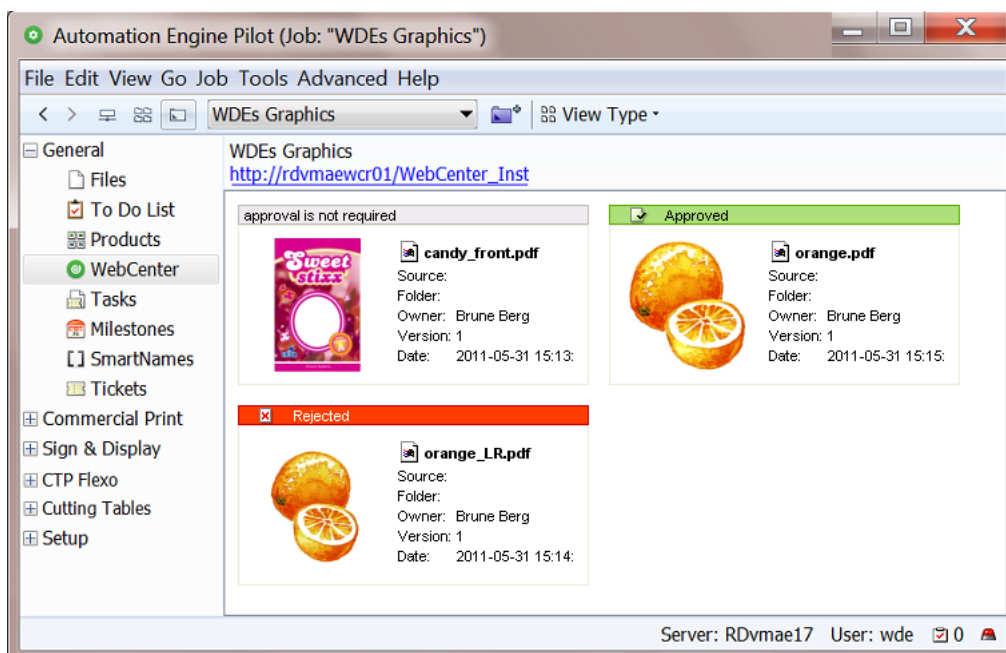

**Tip:**

- Press F5 to update the WebCenter view to the latest information.
- Click the blue hyper-link in the top-left corner to open WebCenter in a browser window.

Learn more in the dedicated document on "Commercial Print (Imposition) workflows in Automation Engine". Find it next to the "Complete Manual" of version AE **18.1** on <https://www.esko.com/en/Support/Product?id=Automation%20Engine&ver=18.1>.

## 5.2.6. The Tasks View

### Concept

The Tasks View allows you to monitor, inspect and relaunch all Automation Engine tasks. Each list entry is a separate task or one step of workflow.

- In **Containers** mode, this view shows all launched tasks and workflows.
- In **Last used Job** mode, this view only shows the tasks and workflows for that job.

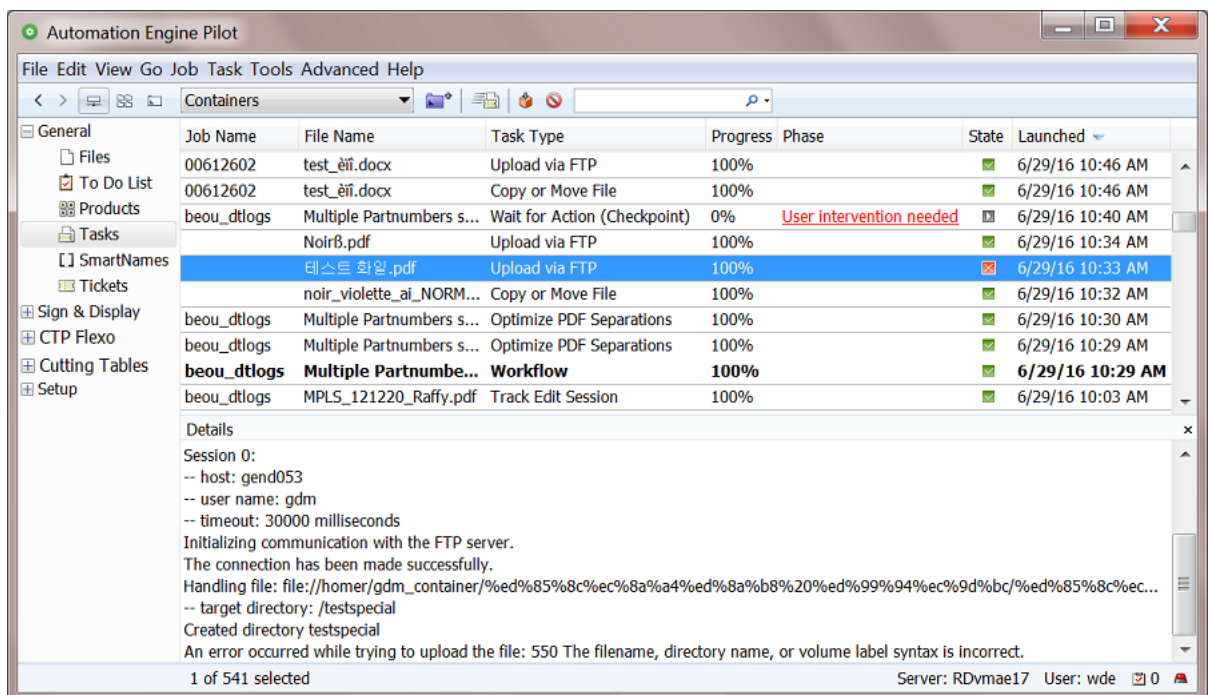

**Note:** Several other views also show a list of tasks in a **Tasks** pane at the bottom.

### Don't forget to clean up!

These launched tasks and their options are kept in a database. Although you can keep many thousands of tasks in this view, when you do not clean up this list, the size of this database will eventually cause slow response and even cause the server software to slow down.

There are manual and automatic tools to clean up this list:

- (Filter), select and press **Delete**.
- Set up a set of automatic [Task Cleanup Rules](#) in the Configure tool.
- Set up a set of automatic rules to **Move Tasks to History**. The **Task History** tool is basically another dedicated database, where you can also search and even relaunch old tasks. Learn more [here](#).
- (Filter), select and press **Move to History**.

Learn more details in [Functionality on items in Tasks View](#) on page 126.

### Sorting, Filtering and Managing Columns

As many other views, this view allows to

- Sort, by clicking on the header of the column you want to sort by.
- Show, hide or change the order of columns by going to **View > Select Columns in 'Tasks'...**



**Note:** To easily hide a column, right-click its header and choose **Hide**.

- Filter, by typing in the search field in the tool bar or by specifying a filter. Learn more in [Using Filters and Creating Smart Views](#) on page 140.

### Details

Select an entry in the **Tasks** list to show its **Details** below. This offers you a summary of the log file with information meant for the user. It is also translated.

It can also contain links to related files. See this example of the details of the 'preflight' task that offers a direct link to the preflight report file:

File Name	Task Type	Progress	Phase	State	Launched
banana.pdf	Trap with PowerTrapper	100%			12/2/14 2:19 PM
banana.pdf	Preflight with PitStop	100%			12/2/14 2:19 PM
banana.pdf	Workflow	100%			12/2/14 2:18 PM

Details x

Task Type: **Preflight with PitStop**

Started on Server: rdvmaedemo 

Started at: 12/2/14 2:19 PM

Finished at: 12/2/14 2:19 PM

Process Time: 0:00:04

---

Input file: file://rdvmaedemo/ExampleJobContainer/6789/banana.pdf

Number of errors: 6

Error: PDF/A-2u : PDF/A Output Intent is missing

Error: PDF/A-2u : Non- PDF/A-2 compliant compression filters have been found

Error: PDF/A-2u : PDF/A version is not PDF/A-2u

Error: PDF/A-2u : CMYK is used while Output Intent is not defined (106x on page 1)

Error: PDF/A-2u : Halftone is not PDF/X compliant (498x on page 1)

Error: PDF/A-2u : 132 XMP schema descriptions are wrong or not embedded in the metadata streams

Number of warnings: 0

Number of fixed issues: 0

Report of the PitStop engine check (PDF) [report](#) 



**Note:** In the Tasks View, you see the **Details** in a separate pane. In other views that also show a list of tasks, you can request to see the **Details** in a separate dialog (right-click on a task item and select **Details**).

### Functionality on items in Tasks View



**Tip:** Most of these functions offer a keyboard shortcut. They are mentioned in their **Task** menu item.

- **Go to Job:** When this task was launched in the context of an Automation Engine Job, this will open that Job in the **Last used Job** mode. Learn more about working with Jobs in the chapter [Jobs](#) on page 538.

- **Open Task:** This opens the task's dialog so you can check the used parameters. You can also relaunch the task, with or without first changing parameters.
- **Open Output File:** This opens the output file in the default application for that file type on your computer. For example: Adobe Acrobat Reader can be assigned to open PDF files.

If the task created multiple files, you will be shown a list of files to choose from.

- **Open Output File With:** This allows to choose from applications that you registered by browsing to the locally installed application (on Windows to its .exe file). For example, this is how you register an ArtPro+ 22.03 from a Pilot on that same client computer:

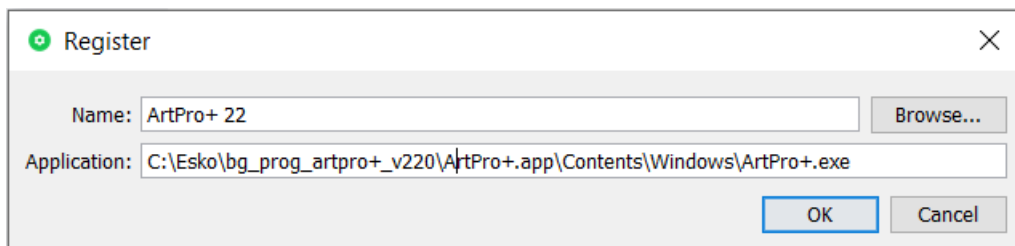

Select **Other...** when you want to register a new or a first application.

- **Go to:** This opens the **Files** or **Last used Job** view and there selects the (chosen) **Output** or **Input File**.
- **Hold:** To put a **pending** task on hold.
- **Hold until...:** To put a **pending** task on hold till a specified time.
- **Release:** To release a task that was on **hold**.
- **Cancel:** To cancel a running task. Depending on the task type and its **Phase**, this happens instantly or can take several seconds.



**Note:** When it takes longer (for example a minute), right-click the task again and check if the system now offers you the option to **Force Quit**.

Once the task is successfully cancelled, it will show its new state: .

- **Priority:** To change the priority of a **pending** task.
- **Relaunch:** To relaunch the task with the same options. When you want to change any task option, first choose **Open**, make the changes and then click **Launch** in that dialog.
- **Delete:** To delete the selected task(s) from this view. You will be asked to confirm.
- **Move to History:** To move the selected tasks to the **Task History** database. This also deletes it from this **Tasks** view.
- **Annotation:** To see the annotation that was added when launching this task. Or to change or add an annotation even after the task is finished. You can for example use this to explain your colleagues why you used specific parameters or that you already contacted Esko regarding an error in the task.



**Tip:** To easily see if tasks have annotations, switch on the column '**Annotations**'.

- **Log Info:** The **Log** file not only contains the task's **Details** (see also below) but also a lot of detailed technical information. This level of detail can be interesting when searching for the cause of errors. It is mainly meant for Esko support people.
- **Open...** This shows the log information of the selected task in the **Log** dialog. When the task is still running, click **Refresh** to see the latest content.

You can send an E-mail containing this log file and attachments.

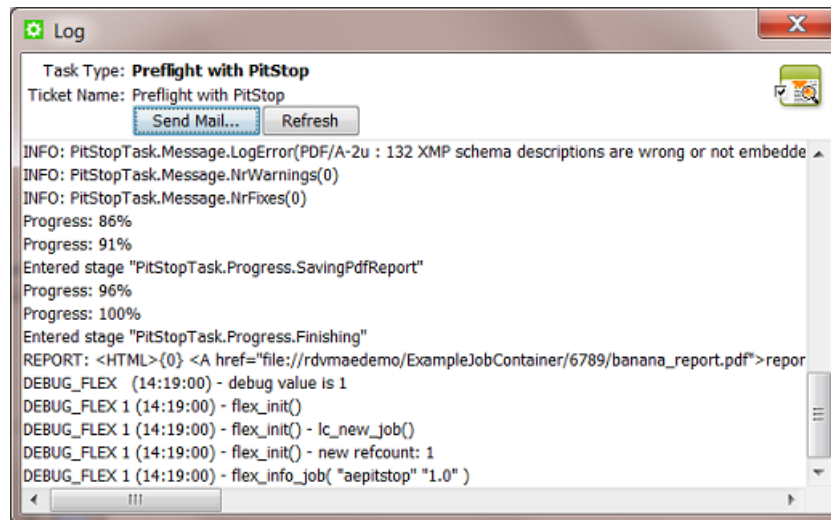

- **Open with:** To open the log file in a text editor installed on your client computer. **Register** that application in the same way as you can do for the option '**Open Output File With**'.



**Note:** This requires the Automation Engine client to have access to the network share 'AutomationEngineLogging' on the Automation Engine server.

- **E-mail...:** The **Compose E-mail message** dialog allows to send this log info in an E-mail, using the E-mail configuration as set up in **Tools -> Configure**. Fill in the E-mail address(es) and change the **Body** message as you wish. By default all relevant files are already attached (remove any if you want to).



**Note:**

- Multiple addresses in one field need to be separated by a semicolon ( ; ).
- When you here use SmartNames, make sure they resolve to a valid e-mail address.

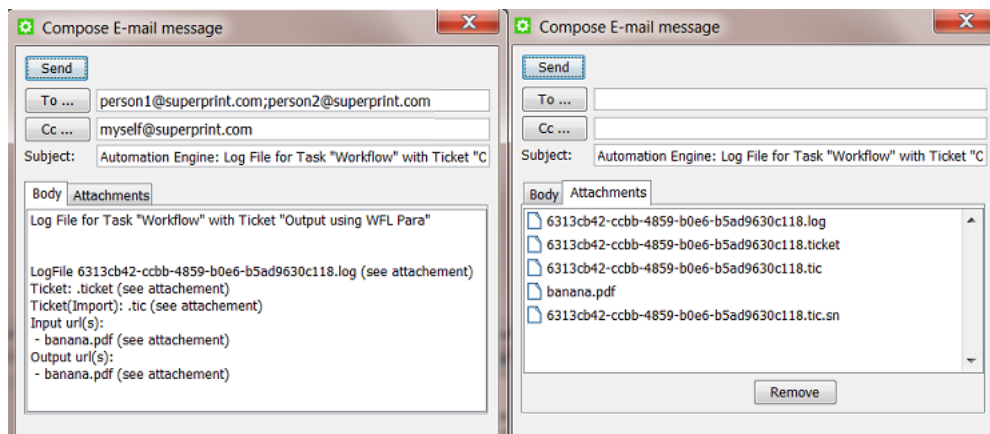



**Note:** Files with extension `.ticket`, `.tic` and `.sn` are file types that Esko support can read.

- **Group by Workflow:** In a view ordered by the time that the tasks were launched, this function groups all steps of a workflow together, even when other tasks happened in the meantime. The first step of the workflow is then shown in bold. Open the bold item to open the whole workflow in stead of only the selected step.



**Note:** This view is overruled when you click on the header of the column '**Launched**'.

- **Display Related Tasks:** Select this to only see the tasks that are part of the same workflow. To go back to your previous tasks view, click the button '**All Tasks**' or '**Tasks**' that appeared on top of the list.



**Note:** This is useful when you are already using a **Filter** that only shows the tasks where "**Task Level = Main Task**" (only showing the single tasks and the bold initial steps of workflows). You can then for example select the workflow with an 'error' status and ask to see its related tasks.

- **Display All Tasks.** When viewing only the related tasks, use this to see all tasks.

## 5.2.7. The Milestones View

The [Milestones View](#) is documented in the dedicated chapter on [Jobs](#) on page 538.

## 5.2.8. The SmartNames View

The **SmartNames** View and Tool is documented in the dedicated chapter [SmartNames](#). Find a direct link [here](#).

## 5.2.9. The Tickets View

### Concept

A **Ticket** is a set of **Task** parameters. In this view, you can create, delete, export or import tickets (single tickets or workflow tickets). You can make them **Public** or add **Tags**. Learn more below in [Functionality in Tickets View](#) and [Importing \(Workflow\) Tickets](#) on page 134.

- In **Containers** mode, this view shows all **Global Tickets** (yellow icon).
- In **Last used Job** mode, this view shows all **Global** and **Job Tickets** (blue icon) of the selected **Job**.



**Note:** Viewing tickets is also one of the [Access Rights](#) a user needs to have.

An example (filtered to all tickets that support PDF files as input file type):



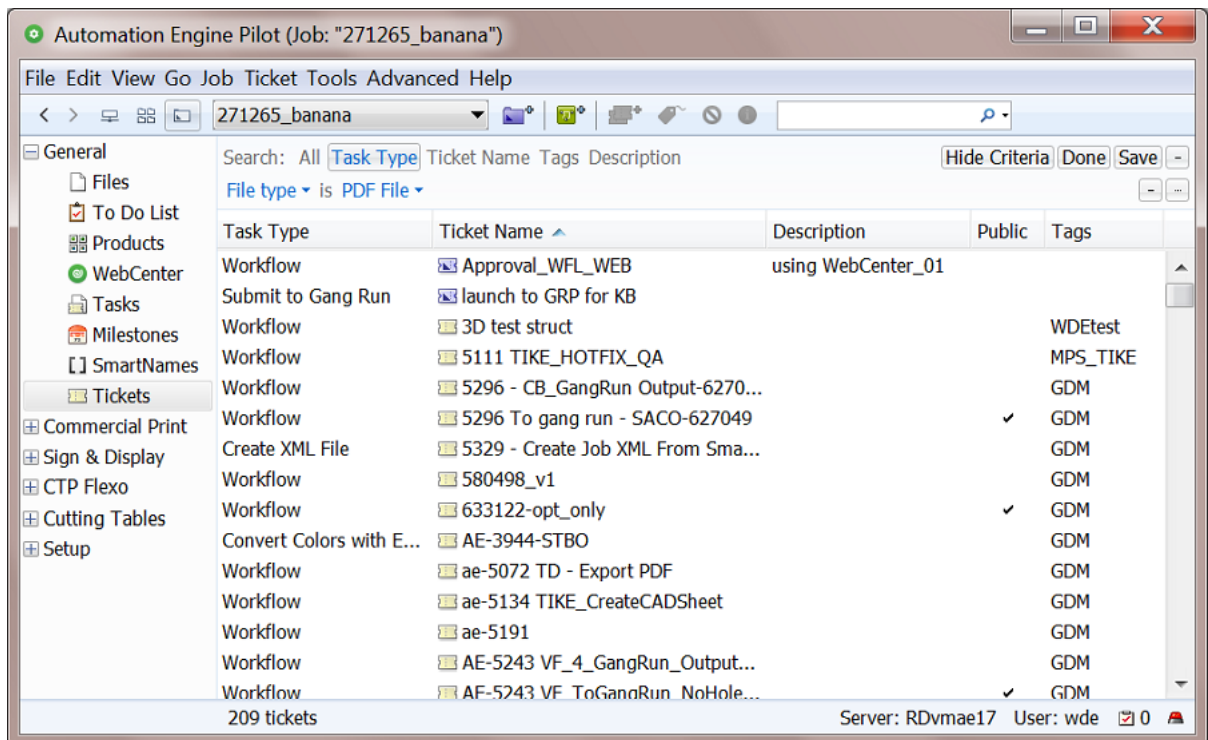

**Note:** Creating tickets and using them to launch tasks is described in [Creating Task Tickets](#) on page 89.

### Sorting, Filtering and Managing Columns in this View

As many other views, this view allows to

- Sort, by clicking on the header of the column you want to sort by.
- Show, hide or change the order of columns by going to **View > Select Columns in 'Tickets'...**
- Filter, by typing in the search field in the tool bar or by clicking on the arrow in  and specifying a filter. An example:

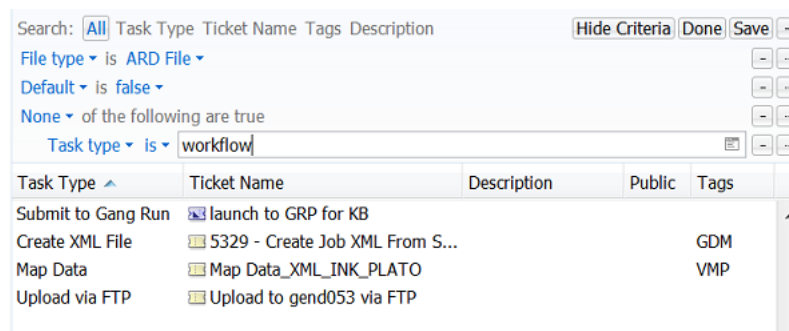

Learn more in [Using Filters and Creating Smart Views](#) on page 140.

### Locked Tickets



These tickets will show the icon that they are 'locked': 

These tickets are delivered by Esko. They are either

- default tickets: The initial default tickets of every type of task.
- proposed workflow tickets, typically default workflows for a specific kind of production.
  - These also have tags and a description to illustrate what they are for.
  - When you open them, a yellow sticky note in the background reminds you that this is a workflow ticket delivered by Esko.

What does the lock do?

- Locked tickets can not be changed, renamed, overwritten, exported nor deleted.
- Locked tickets can be opened and added to favorites.
- Locked tickets can be duplicated by users that have the access right "**Tickets: create/modify/delete (Job tickets only)**"



**Note:** The filter and search fields also allow to search for tickets where the attribute 'Locked' is 'true' or 'false'.

### Tags

You can add multiple **Tags** to a ticket. This allows to sort and filter based on those tags.

### Preferences on Viewing Tickets

Go to the Pilot's **Edit > Preferences** for [specific options on viewing Tickets](#).

### About the attributes 'Modification Date' and 'Modified By'

When a ticket is opened and saved, the attributes 'Modification Date' and 'Modified By' are updated.

The 'Modification Date' and 'Modified By' attributes stay the same when

- updating the Tags,
- updating the Description,
- making the ticket Public/Private,
- renaming a ticket.

When importing a ticket, the attribute 'Modification Date' is taken from the imported ticket. The attribute 'Modified By' is updated to set the user who imported the ticket.

### About Ticket Size

One of the available columns in this view shows the **Size** of the ticket (in bytes, Kb, Mb)

The larger the size of a ticket the slower it will be to work with it (opening, saving), also for the server in background.



**Warning:** When a (workflow) ticket reaches a size of 1,9 Mb, a warning will appear when saving it. You will still be able to save and use it, except when the server is an AE SaaS setup.

Learn about reducing the size of tickets in [Ticket Size](#) on page 136.

## Functionality on items in Tickets View



**Note:** Creating tickets and using them to launch tasks is described in [Creating Task Tickets](#) on page 89.

### Tool bar functions



**Note:** Depending on your [access rights](#), you may not be able to create, edit or delete tickets.

- : To create a new workflow ticket. Learn more in the chapter [Workflows](#) on page 733.
- : To duplicate the selected ticket. Learn more [here](#).
- : To delete the selected ticket(s). You will be asked to confirm.
- : To add or manage **Tags**, extra info fields that help filtering.
- : To see or add info (a **Tag**, a **Description**) or to make the ticket [Public](#).

### Functionality via 'Ticket' Menu or via Right-Click

- **Copy from other Job...** (only via the 'Ticket' menu):

This enables copying a (blue) **Job Ticket** from another **Job** to the current **Job**.

- **Export Ticket(s)...**

Use this to export tickets so that they can be imported on **another** Automation Engine server.

Select the ticket(s), click **Export Ticket(s)...** and choose the location and file name of the exported data (a ZIP file). Then transfer that ZIP to the other server and there choose the 'Import Tickets...' function.

The resulting ZIP file not only contains the selected ticket(s) but also the resource files that these tickets refer to and require (\*):

- **SmartNames**
- **Tickets:** Referred global tickets. Learn more in [The Difference between a Subworkflow and a Referenced Workflow](#) on page 748.
- **PDF Action Lists** and **ArtPro Action Lists**
- **PitStop Profiles** and **PitStop Action Lists**
- **Dynamic Marks** and **SmartMarks**
- **Tiling Templates** used in **Create Tiles (Classic)**
- **CAD Styles** and **CAD Tunes** used in **Prepare Station (Classic)**, **Create Sheet Layout** and some **Step & Repeat** tasks
- **Files:**
  - Templates in all types of **Step & Repeat** tasks

- Report templates in **Create PDF Report** and **ReportMaker (Classic)**
- Database and Header file in **Expand Dynamic VDP template**
- PDFs to compare with in **Compare PDF (Classic)**,
- XML files used in **Create Design (DesignWizard) (Classic)**,
- Templates used in **Create Imposition from RunList**
- Print Rule sets used in **Check Print Rules (PRC) (Classic)**
- PPD files (Postscript Printer Description)
- Resources used in Global Vision **Inspect** tasks: **Compare Artwork, Barcode, Text Profiles, Braille, Spelling Languages**
- **Cutting Flows** in **Submit to Plate Merger**
- **Scripts** used in **Run Script**.



**Tip:** (\*) These resources are also the ones you will see listed in the Workflow Editor when using the [Show Resources pane](#) (🗄️).



**Attention:** This tool to export tickets has these limitations:

- These ticket resources are not included in the exported ZIP file:
  - **DGC** files and **CMS** related files like **Color Strategies**.
  - Plate templates used in **Import JDF Stripping**.
  - The template used in **Create IMP File (Classic)**.
  - XML or CSV database files that define a grid in **Expand Variable Data to PPML File (Classic)**.
- Workflows that include (blue) **Job Tickets** by reference can not be exported. An error message will appear.





**Attention:** The Automation Engine software version on the server that imports the ZIP may not be on an older version than the Automation Engine server that created the ZIP.

- **Import Tickets...** (only via the 'Ticket' menu):

Use this to import tickets that were exported from **another** Automation Engine (by using the **Export Ticket(s)...** function on that other server).

Learn more below in [Importing \(Workflow\) Tickets](#) on page 134.

- **Open:** To open the ticket. Alternatively, double click the ticket.
- **Make Public:** To make the selected tickets public. A public ticket is visible to all users, not just to its creator. Alternatively, set this attribute the moment you save a ticket. Learn more in [Public Tickets](#).
- **Duplicate...** (or ): To copy a ticket and save it with a different name, without opening the ticket.

- **Delete** (or ): To delete the selected tickets. You will be asked to confirm.



**Warning:** Make sure that the ticket is not used in an Access Point or somewhere in the Configure tool or as a referred ticket in a workflow ticket.



**Note:** Default tickets (any locked ticket ) can not be deleted.

- **Rename:** To change the name of the selected ticket.
- **Tags...:** To assign one or multiple tags to the selected tickets. In the dialog, click in the input field to see a drop-down list with existing tags to choose from. Type in the input field to add new ones.
- **Share:** Workflow administrators can share a workflow ticket to Esko Cloud and optionally also share it with other locations with an Automation Engine server. where if present a same named ticket will be overwritten. Learn more on the page about the task with that same functionality [Share Workflow Ticket](#) on page 1717.
- **Add to Favorites:** To add the selected tickets to the list of **Favorite Tickets** of this user. Learn more in [Creating Favorite Tickets](#) on page 91.

## Importing (Workflow) Tickets

### Concept

Use this to import tickets and their referenced resources from another Automation Engine where they were exported by using the **Export Ticket(s)...** function.

This can also be used when migrating from your on-premises Automation Engine to your Automation Engine SaaS setup.

When the tool detects that a local resource would be overwritten by one that comes with the import action (a marks set, a SmartName...), a dialog will open and allow you to choose what to do, i.e. confirm the overwriting or skip that resource when importing. Learn more below.

Tickets are imported as **Global Tickets** and by default keep their original name.

### Settings

Click **Import Tickets...** and select the ZIP file that contains the ticket(s) and their dependant files and click **Import**. The newly imported tickets will show up selected in the Tickets view (when not hidden by filters).



**Restriction:** You can not import tickets when the ZIP was exported on an Automation Engine with a higher version. For example: On a 22.03 version, you can't import a ZIP that was created on a 22.07 version.



**Warning:** When importing resources that came from a central resources folder (for example `bg_data_marks_xxx`), they will automatically be written on the central resources folder of the current server.

Other files (for example **Report** templates or ArtPro mark files referred from an **ArtPro Action List**) will be written in the root of the container "ExampleJobContainer", in a folder named after the folder they originally came from. This is why, when importing tickets, a container named "ExampleJobContainer" must exist and allow writing.

## Managing Possible Conflicts

When importing a ticket would result in overwriting existing resources, an extra dialog will open and list these possible situations. You can there indicate which ones should be excluded from the importing action. Alternatively, you can click **Cancel** to stop the whole import operation.

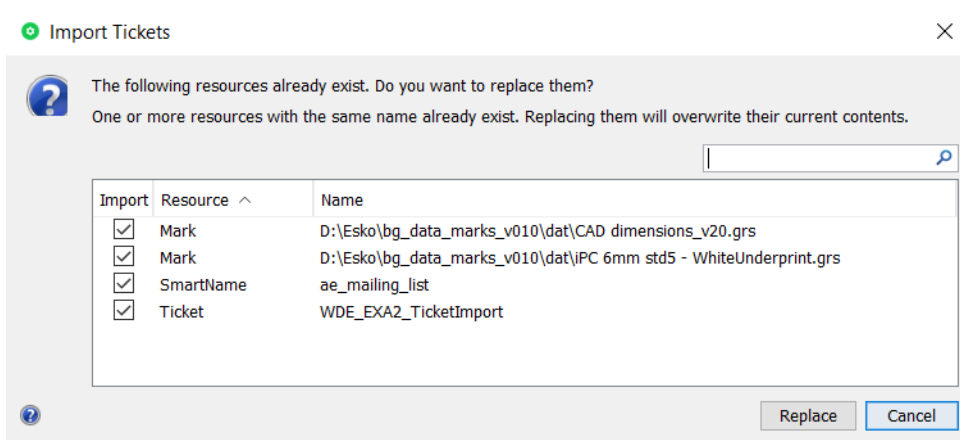

Maybe the overwriting is not a problem when the resource's content is the same, for example a print mark with a same name that is also identical.

But allowing a resource to be overwritten could also, especially in case of SmartNames, cause major problems. Therefore, the main purpose of this dialog is to enable excluding SmartNames from being imported. Learn more below.



**Tip:** (\*) These resources are also the ones you will see listed in the Workflow Editor when using the [Show Resources pane](#) (🗑️).

How to use this dialog:

- You here select which of these resources may replace the existing ones on the target server. By default, all conflicting resources all are selected.
- In the column **Import**, select/deselect individual resources before deciding to continue importing the zip file.

It is also possible to right-click selected resources and choose between **Import** or **Don't Import**.

- The filter tool can help to define your selection.

These 2 types are only listed when their actual content is different (so not just when they have the same name):

- SmartNames are only listed here as a possible conflict when the contents of the SmartName is actually different. Know that also their formatting options are part of their contents.
- Also ArtPro Action Lists are only listed here as a possible conflict when there is a difference in their contents.



**Attention:** Be very attentive when using this tool!

### Comparing conflicting SmartNames

As mentioned above, this tool checks more than just the name of a SmartName, it also checks its content.

In this list, select a SmartName, right-click and choose **Compare** (Open to Compare).

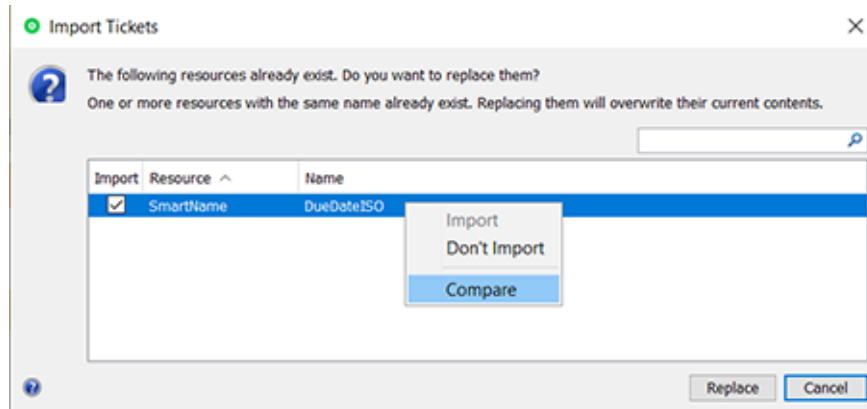

This opens the local SmartName (on the left) and the SmartName from the ZIP file (on the right). This allows you to compare them and detect the differences.

See an example where the difference is subtle: the one on the left contains an extra ' ' between the SmartNames:

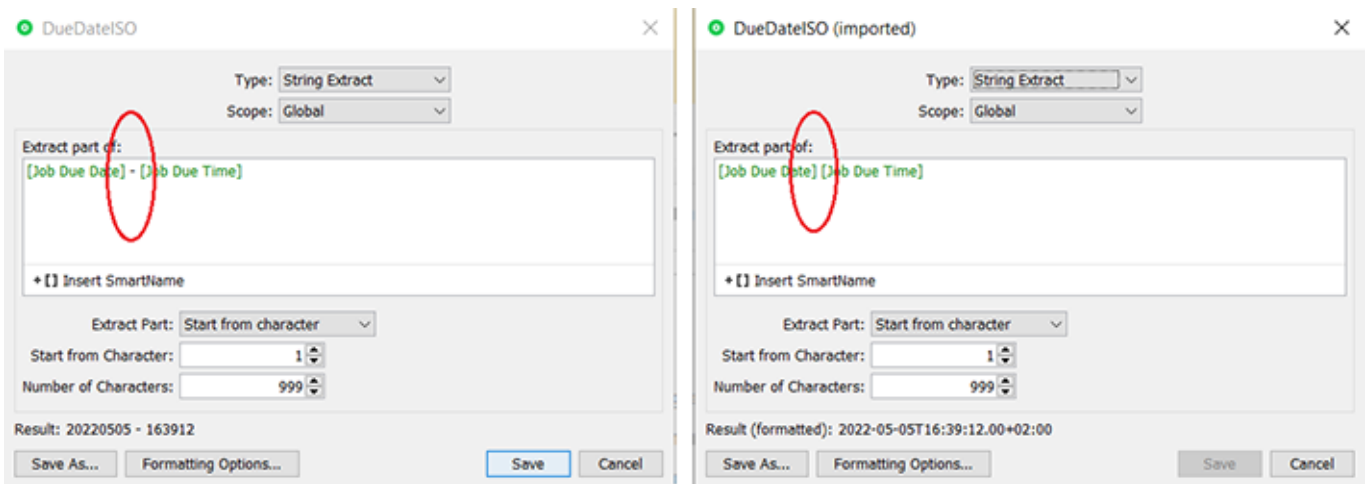

**Tip:** When you do not want the existing SmartName to be overwritten (you exclude it here from being imported) but you are still interested in the contents of the SmartName from the ZIP, you can use the 'Save As...' button to also save that one locally, with a different name then. This is just like creating a new SmartName ; it doesn't affect the import in any way.



**Note:** This dialog does not offer tools to rename SmartNames.

## Ticket Size

### Avoid working with very large Tickets

One of the available columns in the [Tickets view](#) shows the **Size** of the ticket (in bytes, Kb, Mb).

The larger the size of ticket the slower it will be to work with it (opening, saving), also for the server in background.



**Warning:** When a (workflow) ticket reaches a size of 1,9 Mb, a warning will appear when saving it. You will still be able to save and use it, except when the server is an AE SaaS setup. This 1,9 Mb is not a re-configurable size ; it is a hard set limit in the system.



**Note:** The size of (blue) Job tickets is not checked, only that of (yellow) global tickets.



**Note:** The size of the ticket shown in the Tickets view is not the size after you exported it to a ZIP file. Such a ZIP file can be a lot bigger as it also contains all the ticket's external resource files, like profiles, templates, marks, etc.

### Why is this Ticket so big?

A ticket can substantially grow in size when it contains an excessive amount of [public parameters](#). Sometimes these public parameters are present in a subworkflow you do not immediately see.



**Important:** Some workflows load a large list of *workflow* parameters (for example from an XML file). Be aware that by default these *workflow* parameters also become *public* parameters.

### How can I make a Ticket smaller?

- Remove unused public parameters. Use the [Warnings pane](#) in the workflow editor to detect unused public parameters (and much more).
- Add subworkflows as [referenced workflows](#). However, the size of the master workflow should not be a reason to make a choice for a referenced or included subworkflow.

## 5.2.10. The Jobs View

The [Jobs View](#) shows a list of Jobs. It is documented in the dedicated chapter on [Jobs](#) on page 538.



**Note:** The view '**Inactive Jobs**' is only available for AE SaaS setups. Learn more in [AE SaaS: When your AE is in a Data Center](#) on page 1633.

## 5.3. Commercial Print Views

These views serve a workflow dedicated to page workflows (approval, imposition, output).



**Note:** These views are only visible in **Last used Job** mode.

Learn more in the dedicated document on "Commercial Print (Imposition) workflows in Automation Engine". Find it next to the "Complete Manual" of version AE **18.1** on <https://www.esko.com/en/Support/Product?id=Automation%20Engine&ver=18.1>.

## 5.4. Sign & Display Views

---

These views serve an output workflow that is typically used at signage or display or large format printers.

### 5.4.1. The Gang Run Printing View

The [The Gang Run Printing View](#) on page 984 is documented in the chapter dedicated to [Sign & Display Workflow](#) on page 953.

### 5.4.2. The Orders View

The [Orders View](#) is documented in the chapter dedicated to [Sign & Display Workflow](#) on page 953.

It is used to track production orders that come out of a Gang Run Substrate Queue and are then cut on a Kongsberg table.

## 5.5. Flexo Views

---

These views are described in the dedicated chapter [Flexo CTP Device Workflow](#) on page 1482. Find a direct link [here](#).

## 5.6. Cutting Tables Views

---

These views are all described in the dedicated chapter [Kongsberg Production Workflow](#) on page 1565. Find a direct link [here](#).

## 5.7. Smart Views

---

**Smart Views** are custom views based on a filter that you saved.

You can create Smart Views for all View types: lists of Tickets, Tasks, Jobs, Products, To-Dos, Milestones, etc. Smart Views also make it easier to navigate between views.

Here's an example in Job Overview mode:



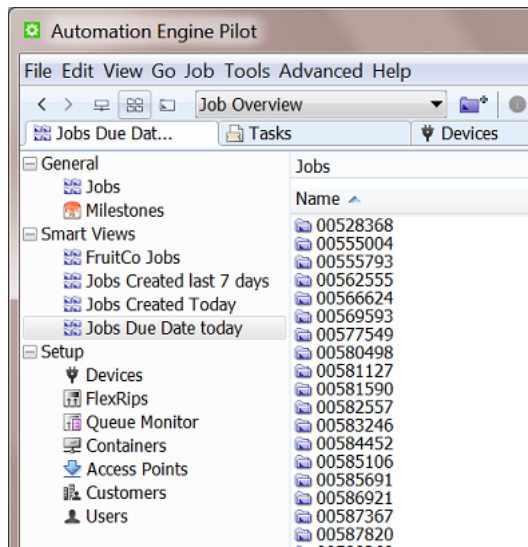

**Tip:** Any Smart Views that you create in the Pilot will also show up for that similar view (page) in [My Workspace](#) (browser client).

Below example shows a Smart View that only shows the To-Dos that are 'pending'. The number indicates how many items are for this user. Below right we see which user is logged in and we see the total of To-Dos for this user (not just the ones that are pending):

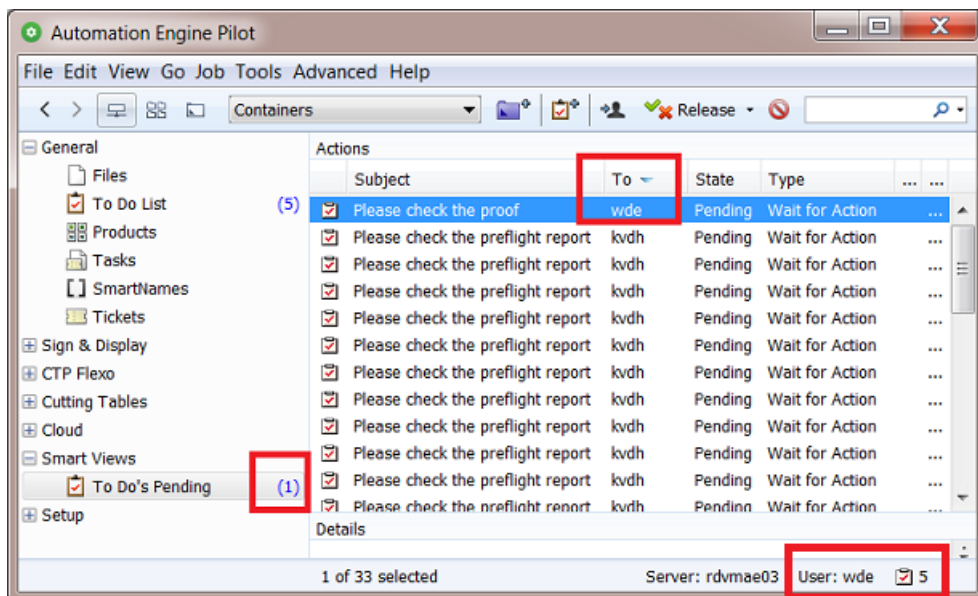

**Tip:** Double click the name of a Smart View to see or (temporarily) change it's filter settings.

How to create a Smart View is explained below.

To remove a Smart View, right-click it and choose **Remove from Views Bar**.

### 5.7.1. Using Filters and Creating Smart Views

A Smart View is filter that you save as a custom view.

We will use an example to illustrate this. Follow these steps to create a Smart View that will filter all tasks based on these criteria:

- Launched by a specific operator,
- During the past two days,
- and ended with a status **'Failed'**.

1. In the Pilot, choose the **Containers** mode and go to the **Tasks** View.
2. Click on the arrow in  or press **Ctrl/Cmd + F** to open the **Search** bar and see the extra filter options that can help you to refine your search:

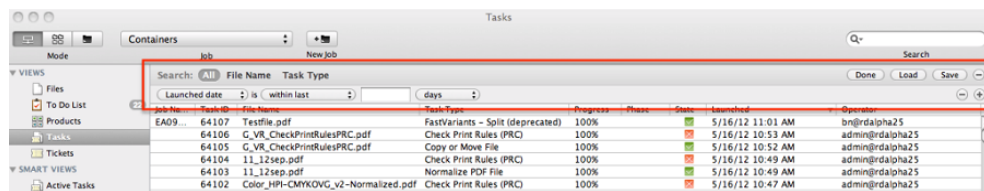

3. Add these filters:

- Set the first filter to **Operator** + **is** + <the operator whose tasks you want to see>. You can click  to browse a list of operators (see (1) in the image below).
- Open a second filter line by clicking the **+** button in the first filter line (see (2) in below image).
- Set these parameters for this second filter: **"Launched date** is **"within last"** 2 **"days"**.

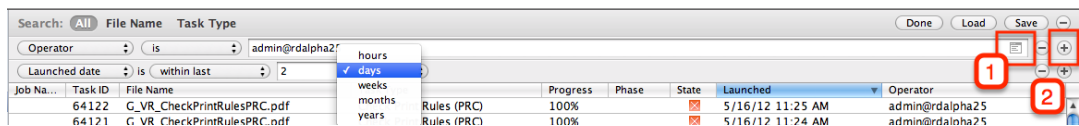

4. Click the **+** sign in the second filter line while holding down the **Alt** key. It changes into a ... sign and allows you to add more criteria to that same filter line.
5. Add these extra filters:

- **"All" of the following are true**
- **"State" is "Failed"**.

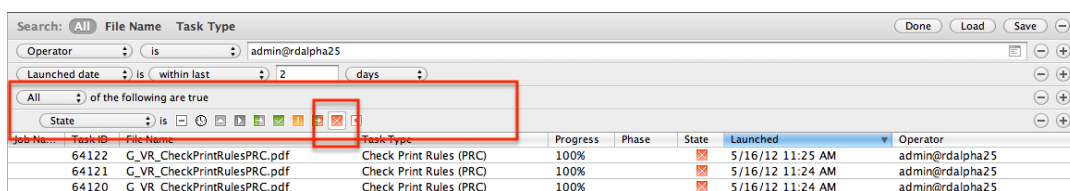

6. Click **Save** to save this filter with an appropriate name.
  - **Scope:** Choose if this filter will be visible to **All users** or to **This user only**.

- Select "**Add to my views bar**" to add this filtered view to the **Views** pane, in the category **Smart Views**.

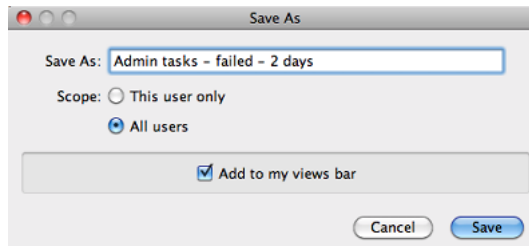

**Note:** If you don't select this, you only save it as a filter that will be available to **Load** again later.



**Note:** Right click a **View** and choose **Manage Filters...** to add or change saved filters.

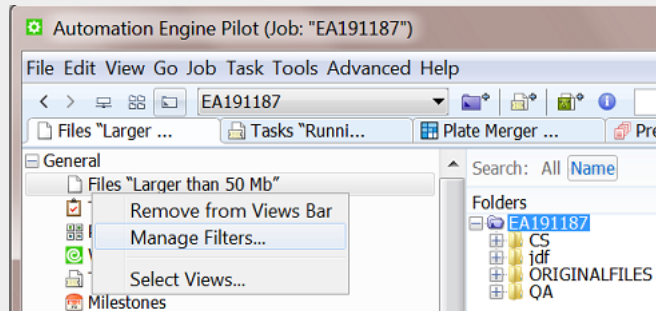

## 5.8. Setup Views

These views offer tools to set up your Automation Engine server.

### 5.8.1. Devices

The **Devices** view shows configured output devices, their status and their workload.

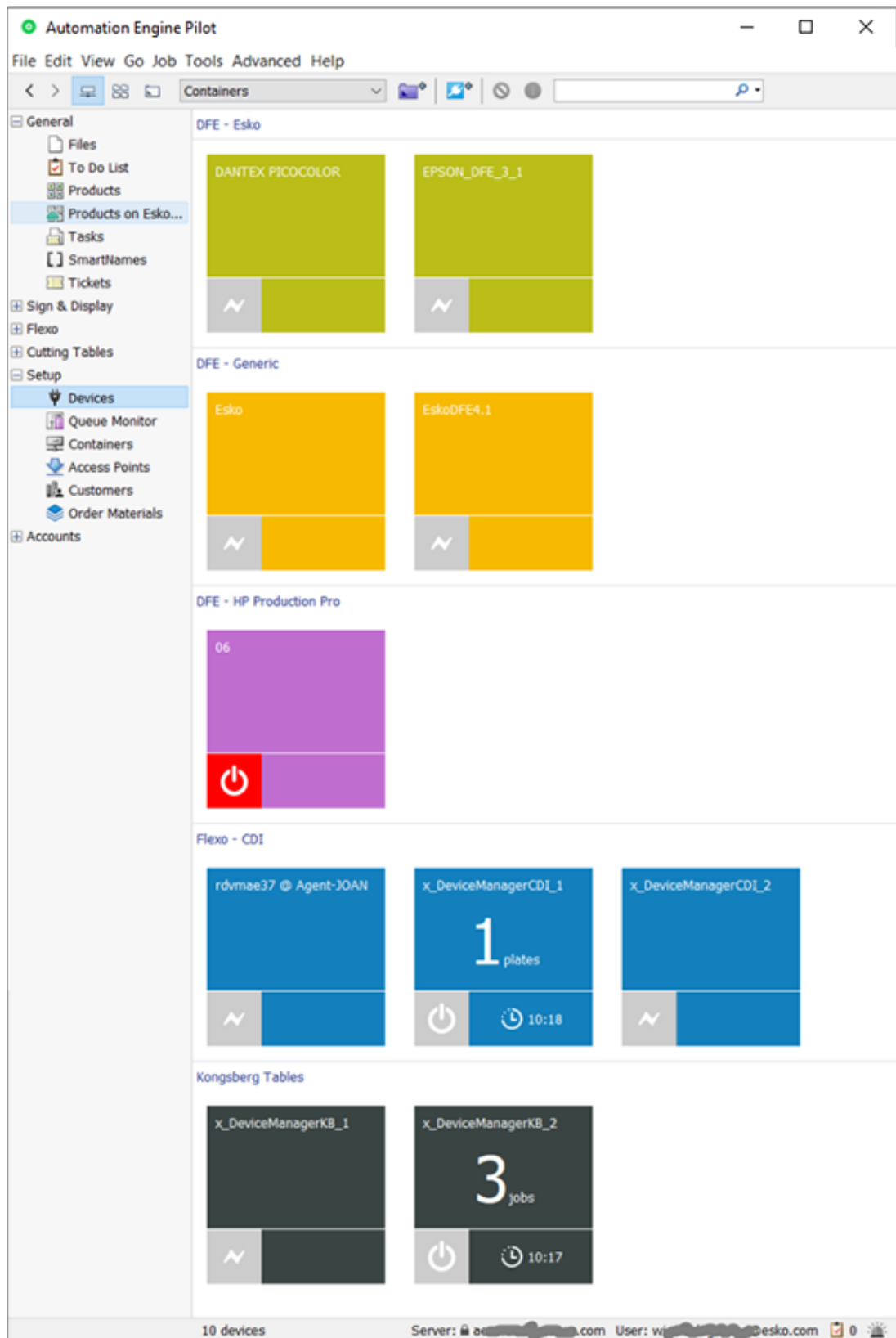

You can add these device types:

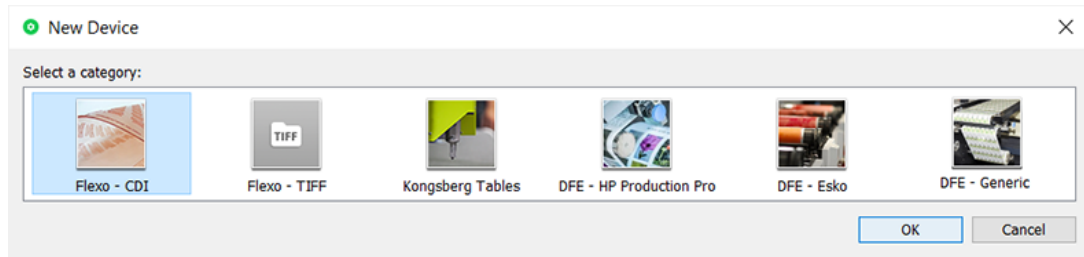

- **Flexo CTP devices.** Esko CDI or Flexo TIFF devices. Learn more in the chapter [Flexo CTP Workflow](#).
- **Kongsberg Cutting tables.** Learn more in the chapter [Kongsberg Production Workflow](#). Find a direct link to the page on Kongsberg devices [here](#).
- Digital presses: **Esko DFE**, **HP Production Pro** and **Generic DFE** devices. Learn more in [Devices \(Digital Presses\)](#) on page 1589.

### 5.8.2. FlexRips (soon outdated)



**Important:** FlexRip tasks will be soon outdated. You are advised to replace them with Imaging Engine tasks. Learn about this in [Concept of \(Soon\) Outdated Tasks / Features](#) on page 531.

The **FlexRips** view and tool gives an overview of the activity on your Esko FlexRips.

It shows the FlexRip's **Name**, **Type**, **Rip Node** (PC) name, its **Port** and the state of the **Dispatcher**. The **Queue Name** is the channel within Automation Engine that communicates with the Dispatcher (this name is part of how you configured this FlexRip it in the [Configure tool](#)).

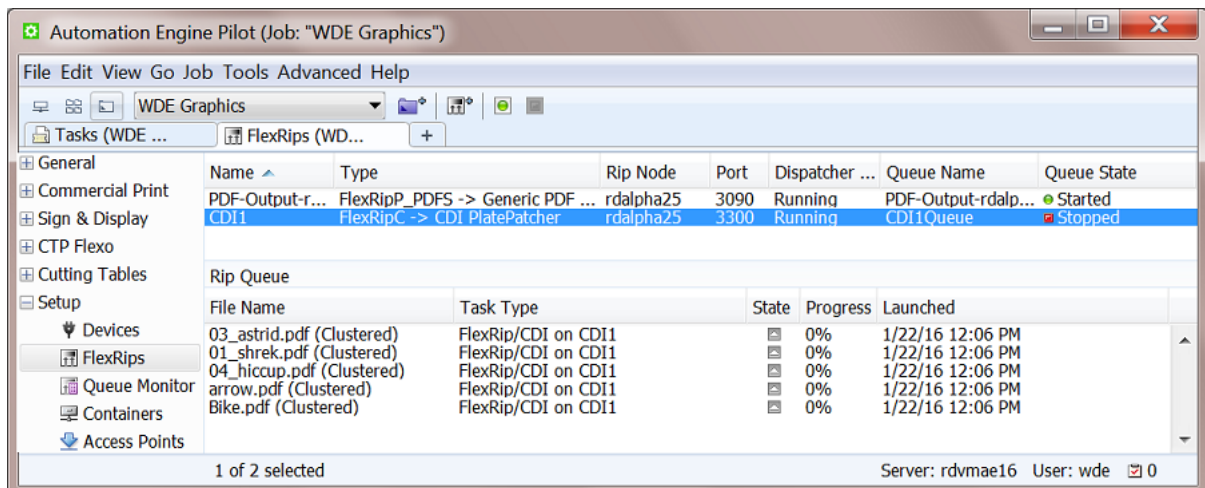

The **RIP Queue** pane shows the queued RIP'ing jobs of the above selected RIP. Go to **View > Select Columns in 'Rip queue'...** to select the information that you want to see here.

When you stop a **RIP Queue** (⏏), you can still send files to that FlexRip but the communication will be queued up within Automation Engine. This can for example be useful when the Dispatcher is located on another computer that you need to shutdown or reboot. To avoid any communication problems between Automation Engine and that Dispatcher, you can stop this queue, do the intervention on the

Dispatcher's computer, and then start the queue again (🟢) when you are sure that the Dispatcher is back up and running.

Click 🛠️ for quick access to the [Configure tool](#) to manage your FlexRip configurations.

### 5.8.3. Queue Monitor

#### Concept

The **Queue Monitor** shows Automation Engine's processing queues and their content. All tasks are executed within one of these queues.

Automation Engine uses many different queues to process its tasks and can grant priority to some types of activity. For example lighter tasks, that only take a few seconds, always get priority over heavy calculations that typically take many minutes. This is for example why a **'Manage Milestone'** task will not have to wait for a **'Trapping'** task to finish.

Which types of tasks are executed on which processing queue is defined internally within the Automation Engine software. Most tasks are executed on the **'CPU'** queue. As a user you can not choose in which queue your task will be executed, but you can choose its priority within that queue (a standard option when launching the task).

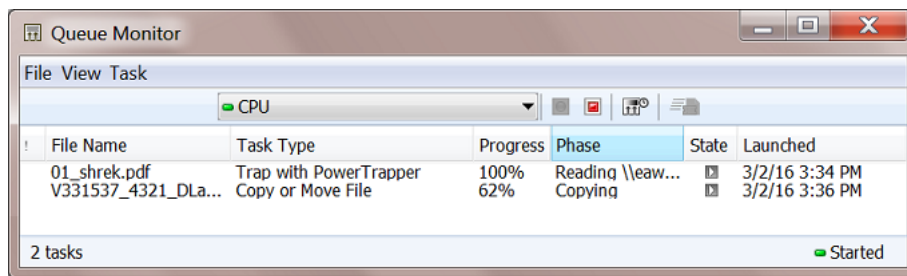

#### Queue Types

- **ADMIN** queue. Used for tasks triggered by events, for example the automatic actions [configured in the Plate Merger's configuration](#).
- **Archive & Restore** queue. Used for such tasks.
- **CPU** queue. The main queue, used for most tasks. It offers the amount of [processing channels](#) as referred to in the [AE Server Admin web pages](#). The more processing channels your Automation Engine server is licensed for, the more tasks it can simultaneously process on this queue ("concurrent running tasks").
- **CPU\_GV** queue. Used to run the [GlobalVision Inspection tasks](#).
- **CPU\_HEAVY** queue. Rarely used. If so, for heavy calculations and pre-RIP'ing processes.



**Note:** Since v16.1, this queue is no longer shown in the [AE Server Admin web pages](#).

- **CPU\_LIGHT** queue. Used for tasks that are light to process.
  - For example these tasks: **Manage Milestone, Link Product to Job, Run Script, Wait for Action (Checkpoint), Track Edit Session, Apply Creep, Change Imposition Layout, Create RunList, Create PDF File from RunList, Add Marks to Imposition, Submit to CDI**, etc.
  - Also the **FlexRip** pre-RIP tasks where the option **'Resolve Transparencies'** was not selected.

- **FTP** queue. Used for [upload tasks to \(S\)FTP or cloud storage sites](#).
- **FlexRip** queues. These are named after the FlexRip and can also be controlled using the [FlexRips View or Tool](#).
- **VDP** queue. Used for expansion tasks in VDP workflows.
- **VIEW\_ACC** queue. In older versions, this one was used to prepare view data



**Warning:** When you open several **Queue Monitors** as a Tool (to monitor multiple queues), you might reach your maximum of licenses for client connections to the server and so get related "Exception" errors. As an alternative, consider opening several tab's in the same Pilot.

### Main Functionality

Use to start or stop a queue. Use to schedule when a queue can be active (see an example below).

A queue's task entries can be opened, relaunched, etc. Right-click to discover options identical to those in a regular Tasks view.

### When is this Tool Useful?

This tool is mostly used by Esko support staff to diagnose CPU load issues. But there are cases where it can also be useful for you:

- The main practical reason to stop one or multiple queues is to help with a controlled shutdown of the server. When queues are stopped, the tasks that would still be launched right before your server intervention then do not risk to fail but stay in this queue "waiting". When you then start the queue again after the intervention, the tasks in that queue will start.
- Some customers only want to start the FTP tasks at night for example. In stead of having to set these "hold-until" times when launching the task, you could for example schedule the FTP queue to be active between 8 PM and 6 AM:

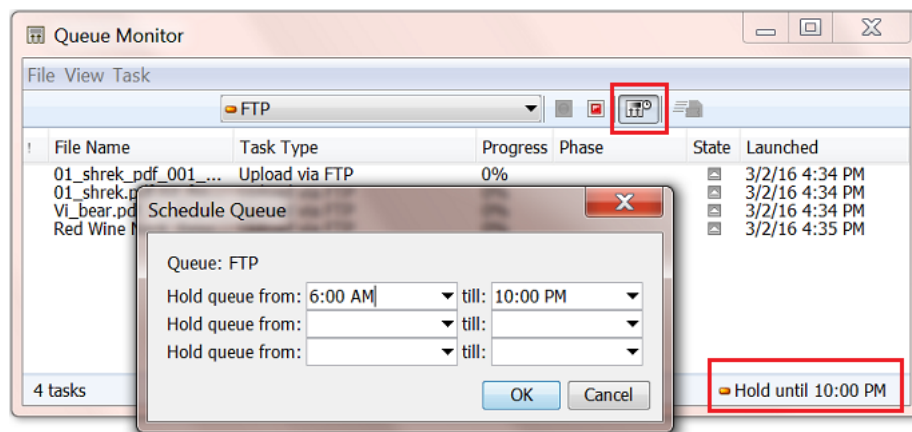

### All Queues Stop Automatically when Not Enough Disk Space

When the drive where AE's workflow manager software is installed (bg\_data\_fastserver\_\*) has less than 3 GB disk space, all task queues are automatically stopped.

Users of the Pilot will see this warning pop up:

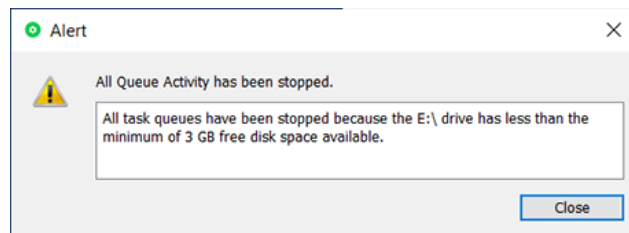

**Note:** This check can also be done manually in [Server Admin # Server Checks](#).

A *Red Alert* will mention the same information.

The queue monitor will show this message in a yellow banner:

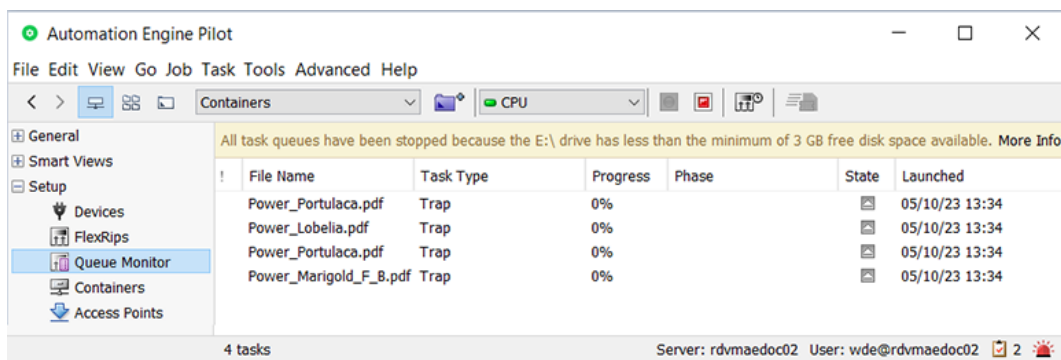

Also, a request to change the priority of a queue entry to 'immediate' opens an error message explaining that disk space first needs to be freed up.

The queues automatically resume when 5 or more GB is available again.

### 5.8.4. Containers

A **Container** is a network share that contains data that Automation Engine can work with. These containers can be located on your Automation Engine server or on another computer in the same LAN.

**Attention:** Also when your Automation Engine server is a SaaS setup, its Containers also need to be in the network of that hosting company. Learn more in the chapter [AE SaaS: When your AE is in a Data Center](#) on page 1633.

You can create a container by using (part of) an existing network share or you can have Automation Engine itself create the network share while it creates the container.

The installation of Automation Engine by default creates an **ExampleJobContainer** on the disk drive where you installed the server software.

You can add many more containers. You can see and browse through them in the Pilot's **Containers** mode. An example:



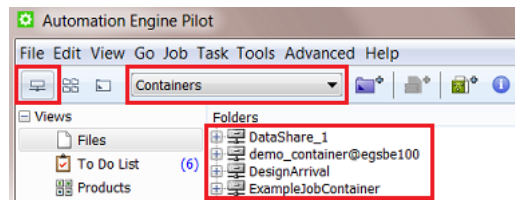

## Creating a Container

Follow these steps to create a container:

1. Open the **Containers** view or go to **Tools > Containers** to open it as a separate window.

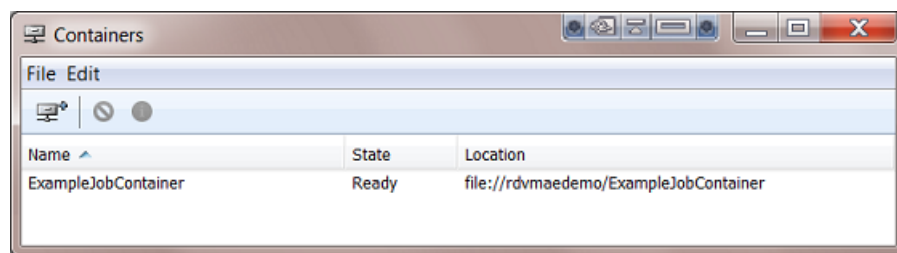

2. Click or go to **File > New**.
3. In the **Create Container Wizard**, click **Next** and select either:
  - **Local Folder on the Server** to create a container on your Automation Engine server.
  - **Existing Shared Folder** to use an existing network share.
4. Click **Next**.
5. If you selected **Local Folder on the Server**:
  - a) Select the wanted disk drive and click **Next**.



**Tip:** Select a drive to see which containers are already in there.

- b) Enter a name for your new container and click **Next**.
  - c) Click **Next** to create another container, or **Finish** to leave the wizard.
6. If you selected **Existing Shared Folder**:
    - a) Enter the **Computer Name** of the computer where the shared folder is located, or use the **Browse...** button to select that computer in your network. Then click **Next**.
    - b) The wizard now shows a list of all available shares on that computer. Select the share you want to use as a container and click **Next**.



**Attention:** Shared folders are not shown when their computer does not recognize the user that was chosen to be the **System Account** for Automation Engine. By default this is the local user **BGSYSTEM**, but you might have changed this (using the [System Account page in the Server Admin web pages](#)).

- Your container is now created.
- c) Click **Next** to create another container, or **Finish** to leave the wizard.

### Removing a Container

Removing a container makes its contents invisible to your Automation Engine server. This does not delete any data inside that share.

To remove a container, select it and click  or press 'Delete' or use **File > Remove**. You will be asked to confirm.

- If there are active **Jobs** on page 538 in that container, they will be listed in the confirmation dialog. If you remove the container anyway, the Jobs are removed from the database and their blue **Job Folders** will become normal yellow folders.

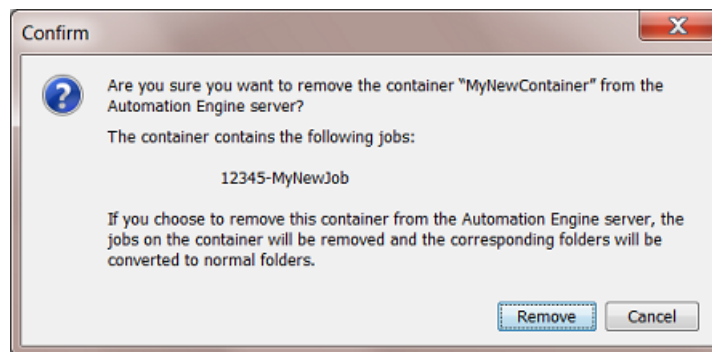

Learn more about removing Jobs [here](#).

- If there are active **Products** on page 594 in the container, you can not remove that container.

### Relocating a Container

When a container goes offline, this will be shown in the Pilot's **Container** mode and in the **Containers** View and Tool:

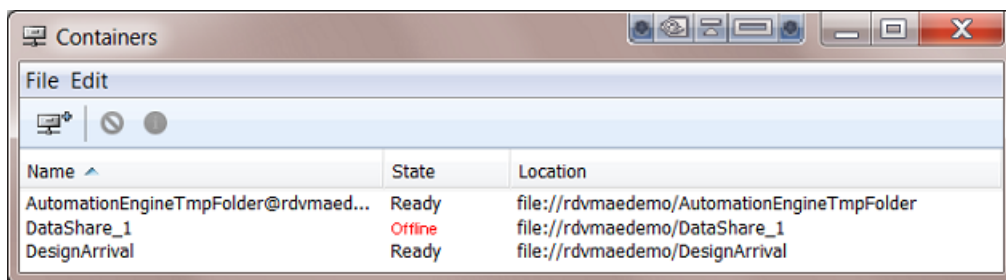

Here are some possible reasons:

- (Temporary) network problems.
- The **Location** is no longer valid because the name of the computer or the share changed. For example the disk was filling up and you decided to move the data to another computer with another name and then remove the old share.
- The disk that hosts this container crashed. When you have a backup of that disk, you can put that data back on another disk or computer.

For whatever reason you need to move data to another network place, you can use the **Relocate** feature to inform Automation Engine that the container data is now on another **Location**.



**Attention:** Relocating does not move any data. It only adapts the Automation Engine database by informing it on the new location.

Follow these steps to relocate a container:

1. Select the offline container and right-click or go to **Edit > Relocate**.
2. Enter the name of the computer that you want to relocate your container on, or browse to it.
3. In the **Select the share** dialog, select the share you want to relocate your container on. Click **OK**.  
Your container is now relocated on the share you selected (and has the name of the share).

### Refreshing the Containers' List

By default, each container's availability is automatically checked every 5 minutes. Sometimes, you want to check it manually, for example after you solved a network problem. Then choose one of these methods to refresh the connection:

- Go to **Edit > Rescan**.
- Press **Cmd + R** (Mac) or **Ctrl + R** (Windows).
- In the Pilot's **Files** view, when using the **Container** mode, press **F5** (Windows).

### Troubleshooting Containers

These messages explain what is wrong with (the creation of) the container:



**Note:** In below examples, the **System Account** for Automation Engine is still the default user BGSYSTEM. This can be a different one if you changed it [here](#).

- Creating a new container fails because the passwords for the user BGSYSTEM don't match:

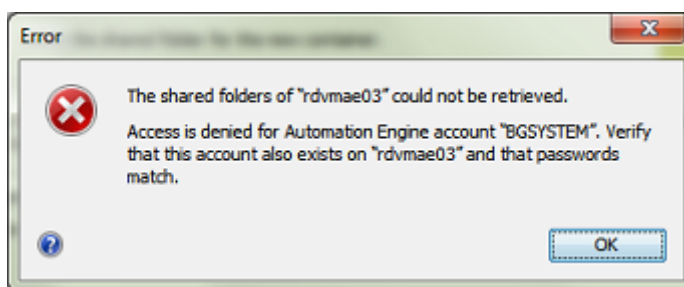

- An **Alert** pops up: A container is no longer accessible. It could be off-line or, as in below example, because the user BGSYSTEM doesn't have full access anymore:

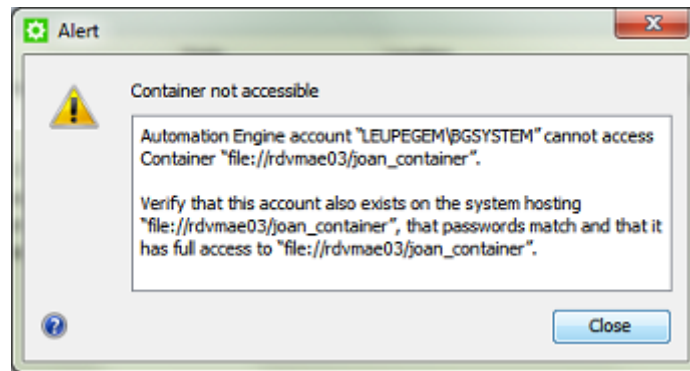

**Note:** When you close this message, the alert is still present in the list of Alerts. This list opens when you click the 🚨 icon in the bottom bar of the Pilot. Learn more in [Alerts](#) on page 2060.

- A container is offline. Select it, right-click and choose **Info** to learn why it is offline:

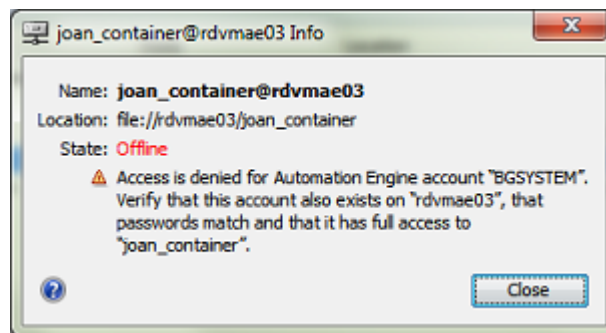

- In the Pilot **Files** view, when the host of the container is down, the warning "Could not retrieve the list of files" appears:

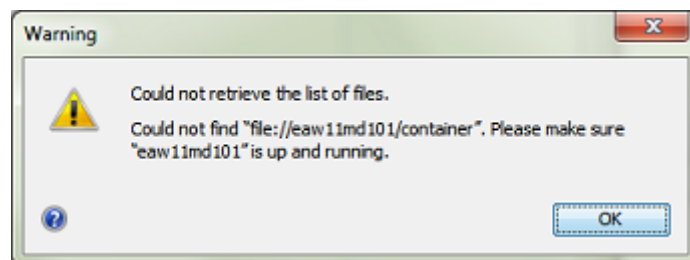

### 5.8.5. Access Points

The **Access Points** View and tool is described in the chapter [Integrating with External Systems](#). Find a direct link [here](#).

### 5.8.6. Customers

#### Concept

This tool allows you to manage the list of customers on Automation Engine.

A customer minimally has an **ID** and a **Name**. You can define many more fields. Go to **View > Columns** to also show those fields as columns.

ID	Customer Name	Contact 1	Job Folder	Product Folder
001	HappyMeds	Dr. Pill	file://eaw11dl306/WDE-AE-Pharma-Data/[Order ID]	
0010	GlossyWorld	Fred Fabulous		
0012	BelgianBrew	Barry Beard		
0013	Esko	Demo Center Esko Gent, BE		
0014	TraffiSign	Theresa Signalski		
004	SuperPrint	Sergio Perfecto		

6 customers

Ideally, you do not type in this customer data but get it automatically via an integration with your business system. Learn more about such integrations in [Integrating with External Systems](#) on page 1769.

#### Fields

Many of these fields are used [when you create a Job, in its tab 'Customers'](#).

Most fields can be used as a SmartName. Learn more in the chapter on [SmartNames](#) on page 637.

- **Contacts, E-mail** and **Address** fields.
- **Job Folder**. This field can help to automatically create job folders for that customer under the folder that you specify here. Learn more in [Smart Job Location](#).



**Note:** Make sure the path you specify here ends with a SmartName already.

- **Product Folder**. When new Products are created automatically for this customer, their Data Zone will be created under this folder and a dummy Product file can also be created there. Learn more in [Smart Product Location](#).
- **Upload Folder** is useful to help instruct Access Points where to upload the data to. Learn more, for example, in [upload options of an FTP Access Point](#).

### 5.8.7. Order Materials

An **Order Material** is the material that your customer wants a **Product** to be printed on. It's the name of the material as your customer understands it and probably also the name he used when he was ordering the production job. This name is the name of that material as it is mentioned on the job order.



**Note:** It is possible that you internally use another name for this material, but in Automation Engine (the browser client used in the QuickStart deployment), we refer to that one as the (real) 'Print Material'.

This view shows the database of order materials on this Automation Engine. It shows you their **Name**, **Thickness**, **Weight** and **Description**.

This list shows the order materials that you can add as an attribute to a 'Product'.

In some *MIS integrations*, where Products are created automatically, also these order materials can be created automatically and so also show up in this view. Learn more in *Task 'Add to Products'* on page 626.



**Note:** Users of the Automation Engine browser client (QuickStart deployment) also manage this same database of order materials. They do this through their browser interface.



**Note:** In this view, the filter can not be saved as a Smart View.



**Note:** This view only shows up when you have the license to use the 'Products' tool.

## 5.9. Accounts Views

---

These views serve to manage the user accounts that can sign in to Automation Engine.

First some important background info on *Authentication and Authorization within AE*.

### 5.9.1. Authentication and Authorization within AE

#### Authentication

- **Concept**

- Authentication is about **validating users** to be who they claim they are, at the time when they attempt to sign in to a system.
- The typical primary authentication factor is checking the combination of a user (account) name and a password.
- Some systems require two- or even multi-factor authentication (MFA), involving more technologies to further verify the identity of the user (for example one-time PINs, phone ring-back, authentication apps, biometric checks).

- Systems can validate their own internal users or can delegate this authentication to an external application. These dedicated applications are called Identity Providers (IdP).
- **Within Automation Engine**
  - When Automation Engine is first installed, authentication comes with checking user name and password, a basic internal authentication.
  - Automation Engine can be configured to delegate this authentication to third party services, which in their turn could be configured to use one or more (other) authentication factors.

Learn more in [Users View](#) on page 153.



**Note:** Learn more technical details in the chapter [Pre Install IT Requirements](#), in the section on [Users and Groups](#) on page 1969.

## Authorization

- **Concept**
  - Authorization is about **granting permissions** to access specific functions or resources. Once signed in, what is this user allowed to do?
- **Within Automation Engine**
  - To a user of Automation Engine, authorization means receiving the permission to
    - qualify as an administrative user or not
    - have specific **User Access Rights** (typically relating to functionality within the Pilot).

## 5.9.2. Users View

### Concept

Everything that happens in Automation Engine is done by a specific user. This user can be a person or a service.

Automation Engine does not come with default users.

At the initial installation of Automation Engine, you are asked to create an administrative user to sign in for the first time, after which you can use that one to create others.

### View

Only Automation Engine Administrator users can see this view.

Automation Engine supports both **Internal** users and users from **external Providers**. Learn more details in the chapter [IT Requirements](#), on the page [Old and New User Model - Before and Since v20](#) on page 1970.

### Creating a New Internal User

After an initial install of Automation Engine server software, the system asks to create an initial administrative user. Using that one, you can then start creating others.

Right-click anywhere in the view and select **New User** (or click  in the top bar).

This tool creates an **Automation Engine internal user**.

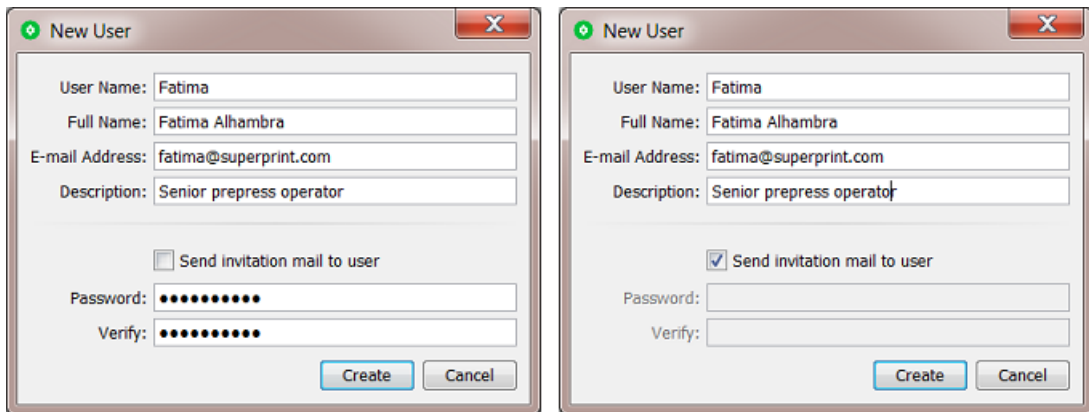

- **User Name:** (required). The name is not case sensitive.
- **Full Name:** This full name can be changed later, which is not possible for the actual user name.
- **E-mail Address:** Specify this user's e-mail address.



**Note:** When editing an LDAP user, you cannot change his e-mail address.

- **Description:** You can add some details, like the user's function, working hours, phone number, etc.
- **Send invitation e-mail to user:**
  - When **selected**, the new user will receive an e-mail with a link to set his own password.



**Note:** Make sure your AE server already has been *configured* to use your e-mail server.

- When **not selected**, you, as admin user, need to set this user's password here.
  - **Password:** Type the password this new user must use to sign in.



**Important:** In the *AE Server CONFIG web page*, your IT staff can choose to enforce a standard set of password complexity rules. When your password does not comply with these rules, you will get a specific error message.

- **Verify:** If you specified a password above, type it again here.

### Columns in the View



Automation Engine Pilot

File Edit View Go Job Tools Advanced Help

Containers

General	User Name	Full Name	Type	Provider	Last Signed In ^	Created
Sign & Display	welc@rdvmaedoc02	welc	Admin	Windows	1/28/21 3:54 PM	1/28/21 3:54 PM
Flexo CTP	koji@rdvmaedoc02	Sakyima	Admin	Windows	1/28/21 3:54 PM	1/28/21 3:54 PM
Cutting Tables	kvha@rdvmaedoc02	Kim Van Hauwe	Admin	Windows	1/28/21 3:54 PM	1/28/21 3:54 PM
Cloud	chyu@rdvmaedoc02	Chen Yu	Admin	Windows	1/28/21 3:54 PM	1/28/21 3:54 PM
Smart Views	kile@rdvmaedoc02	Kinmen lee	Admin	Windows	1/28/21 3:54 PM	1/28/21 3:54 PM
Setup	giho@rdvmaedoc02	Gi-Ho Yoon	Admin	Windows	1/28/21 3:54 PM	1/28/21 3:54 PM
Accounts	stsi@rdvmaedoc02	Steffen	Admin	Windows	1/28/21 3:54 PM	1/28/21 3:54 PM
<b>Users</b>	eva@rdvmaedoc02	eva	Admin	Windows	1/28/21 3:54 PM	1/28/21 3:54 PM
Groups	trap@rdvmaedoc02	trap	Admin	Windows	1/28/21 3:54 PM	1/28/21 3:54 PM
Roles	kvdh	klaas	Admin	Internal	3/30/21 3:35 PM	3/11/21 11:45 AM
	jva	Jurgen vandenbergh	Admin	Internal	3/31/21 3:34 PM	3/3/21 3:17 PM
	wde@rdvmaedoc02	wde	Admin	Windows	4/1/21 10:58 AM	1/28/21 3:54 PM

12 users, 1 online Server: rdvmaedoc02 User: wde 2



**Note:** The search field filters on name, full name, e-mail and description.



**Note:** You can not sort on the columns 'Type' and 'Description'.

- **User Name:** Name used to sign in.



**Note:** In an AE SaaS setup,

- The name of a user created and used by Esko support will show a suffix (managed). Learn more about AE SaaS in [the dedicated chapter](#).
- This list will show an automatically created user for every connected [Agent](#), named Agent User: <NameOfAgent>.

- **Full Name:** Descriptive name.
- **Type:** Admin or [Agent](#) or empty.
- **Provider:**
  - **Internal:** User is provided by Automation Engine (created via this Users view in Automation Engine v20.0 or later).
  - **LDAP:** User is provided by LDAP. Since v21,07, it is possible to define an external LDAP identity provider, which can take over the granting of access for Windows domain users.



**Important:** An LDAP user only appears in this list after its first successful sign-in.



**Important:** LDAP user accounts are not supported for an Automation Engine server in a SaaS setup.

Automation Engine group membership and role attribution can be controlled by this type of provider (typically a Windows domain controller), without the need to adapt local Windows groups on the Automation Engine system.

Existing users, based on domain Windows users, can be migrated to LDAP users too.

- **Windows:** A user from before v20.0 that was converted when upgrading to v20.0.



**Important:** Windows authentication will soon become outdated! Learn more in [Windows - Soon Outdated](#) on page 2005.

You can migrate users to other providers. Learn more in [Users and Groups](#) on page 1969.

- **Last Signed In:** When this user last signed in.
- **Description:** Description of this user.
- **E-mail:** The e-mail address for this user.
- **Created:** When this user was created.

### Other Functionality

Right-click anywhere in the Users view, or first select one or multiple users and choose from below functionality. A few functions are also available via buttons in the top bar.

- **Edit Views...:** Define which Views the selected user will see when he signs in to the Pilot.

When editing the views of an other administrator user, be aware that any administrator user is always allowed to see all views. So he can overrule your settings and switch any of them on again.

- **Edit Access Rights...:**

You can assign specific **access rights** to a user or to a group.

A typical example is to reserve configuration features only for selected users. You can for example fine-tune roles by allowing some users to only use tickets but not being able to *change* them. Learn more on the page about the [Roles View](#).

Administrator users always have all user access rights. You can not take any rights away.

Only Administrator users can change access rights of normal users.

Learn more in [Access Rights](#) on page 157.

- **Edit Red Alerts...:**

When an important event is detected by the Automation Engine server, a **Red Alert** is broadcast to the users. This can pop up as message box and these alerts are indicated in the bottom right corner of the Pilot with the  icon.

When you are logged in as an administrator user, you can choose which type of alerts you yourself or another user should be informed about.

Learn more in [Alerts](#) on page 2060.

- **Show Connections...:** This shows from where and with what application the selected user is currently connected with (signed in to) the server. A user can have several connections.

Possible connections are not only from connected client software (Pilot, Shuttle, browser client), but also from Esko editors (ArtPro, ArtPro+, PackEdge, Plato, DeskPack, etc.)

This dialog is not live. Use the **Refresh** button to manually refresh this list of connections.

The list is empty when the user is not signed in.

- **Show All Connections...:** This shows the connections from all users. A search field helps to filter the list.

- **Copy / Paste:** This tool enables to copy / paste attributes from one user to another: their Favorites, Views, Smart Views, or Red Alerts.

First select the source user and choose **Copy**, then select the target user(s) and, at the moment of **Paste**, select which type of attributes you want to paste to the currently selected user(s). Select **Other** to indicate multiple types.

- **Reset**: An administrator can use this to quickly remove all **Favorites** or **Smart Views** of the currently selected user. This is especially useful during initial trainings or setups of temp users.
- **Delete** . You need the proper access right and you will be asked to confirm.
- **Migrate Users...**: You can migrate users of the Provider 'Windows' to either the provider **Internal** or **LDAP**. Learn more in [Migrating Users](#) on page 1972.
- **Change Password...**:

An internal user can change his own password. Internal administrator users can change the password of any other internal user.



- **Edit User...**: In the view, double click a user to see or change his attributes.

## Access Rights

### Concept

You can assign specific **Access Rights** to a specific User or to Role..

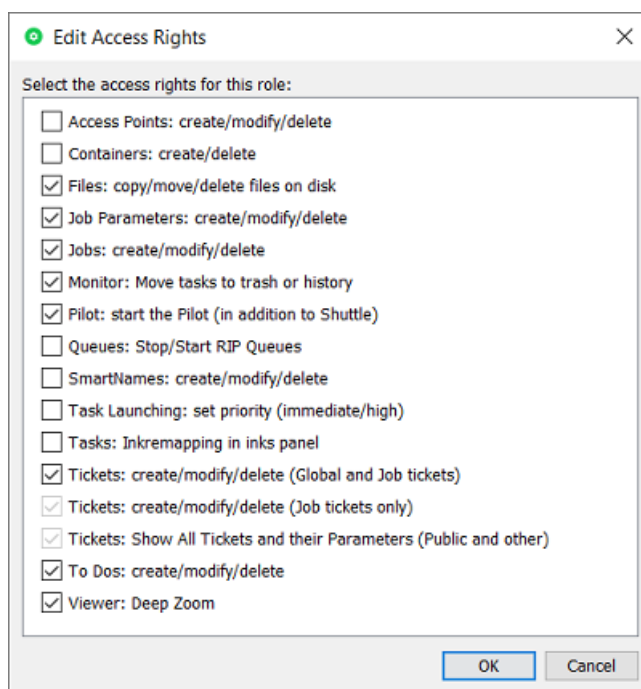

In this dialog, when access rights were granted to the user by being part of a role or a group, they will be selected but disabled.

In above screenshot, an administrator added some extra rights.

**Remove All** (enabled when dialog is opened from users list) will remove all access rights that were given specifically to this user but not those that were granted by being part of a role or a group.





**Note:** Managing these roles will be easier when you do this per user group. A user automatically gets all rights from the group he belongs to.

Some general rules:

- Administrator users always have all user access rights.
- Only Administrator users can change access rights of normal users.

This access right:	is about ...
<b>Access Points: create / modify / delete</b>	managing <a href="#">Access Points</a> .
<b>Color Pilot: create/modify/delete (Colors, Curves and Screens)</b>	Only available on an AE SaaS server. Learn more <a href="#">here</a> .
<b>Containers: create / delete</b>	<a href="#">creation</a> and <a href="#">deletion</a> of containers.
<b>Files: copy / move / delete files on disk</b>	what you can do with files using the Pilot. Note that these users can still use the <a href="#">Copy or Move File</a> on page 272 and <a href="#">Delete File</a> on page 305 tasks.
<b>Job Parameters: create / modify / delete</b>	managing the tab 'Parameters' in a Job setup. Learn more in <a href="#">Creating and Modifying a Custom Job Parameter</a> on page 553 .
<b>Jobs: create / modify / delete</b>	managing Jobs. Learn more in <a href="#">Creating a Job</a> on page 546 and <a href="#">deleting Jobs</a> .
<b>Monitor: move tasks to trash or history</b>	removing tasks from the Tasks list. See <a href="#">Tasks list</a> and <a href="#">Task History</a> on page 164.
<b>Pilot : Start the Pilot (in addition to Shuttle)</b>	being able to sign in to a Pilot.
<b>Queues: stop / start device queues</b>	managing queues in the <a href="#">Queue Monitor</a> and the <a href="#">FlexRip Queues</a> .
<b>SmartNames</b>	managing <a href="#">SmartNames</a> . This access right is also required to open the SmartName's dialog in 'edit' mode.
<b>Task launching: set priority (immediate / high)</b>	setting a higher priority to the tasks this user launches.
<b>Tasks: Ink remapping in inks panel</b>	changing ink attributes in FlexRip or Imaging Engine tickets (LPI, angle, dot, remap, merge).

This access right:	is about ...
<b>Tickets: create / modify / delete (Global and Job tickets)</b>	<p>managing Global and Job tickets. See <a href="#">Tickets</a> on page 83 and <a href="#">Tickets View</a>.</p> <div style="border: 1px solid #ccc; padding: 5px; margin-top: 10px;">  <p><b>Note:</b> This Access Right automatically grants the two below mentioned rights.</p> </div>
<b>Tickets: create / modify / delete (Job tickets only)</b>	managing Job tickets. See <a href="#">Tickets View</a> .
<b>Tickets: Show All Tickets and their Parameters (Public and other)</b>	<p>which tickets and parameters you can see in the Pilot (in the <b>Tickets</b> View, when launching a task or workflow in the <b>Files</b> View, or when opening a task ticket from the <b>Tasks</b> list).</p> <p>When this is deselected, the user can only use:</p> <ul style="list-style-type: none"> <li>• public tickets (see <a href="#">Tickets</a> on page 83)</li> <li>• public parameters in those public tickets (see <a href="#">Using Public Parameters in Automation Engine</a> on page 99)</li> <li>• the <b>Launch with</b> option on files (not the <b>New Task</b> option)(see <a href="#">Launching a Task on a File</a> on page 87 and <a href="#">Launching a Workflow on a File</a> on page 781).</li> </ul> <div style="border: 1px solid #ccc; padding: 5px; margin-top: 10px;">  <p><b>Note:</b></p> <ul style="list-style-type: none"> <li>• Without this access right, a user can not create any ticket.</li> <li>• In the Pilot's <a href="#">Tickets Preferences</a>, you can use the 'Show only ...' options to simulate how the Pilot looks without this access right.</li> </ul> <p>This is useful for an administrator to check which tickets and parameters a user still can see when he takes away this access right from that user.</p> </div>
<b>To-dos: create / modify / delete</b>	forwarding to-do actions to other users. Learn more in <a href="#">To Do List</a> .
<b>Viewer: Deep Zoom</b>	using a deep zoom, both when viewing unprepared files and prepared files (when zoom is deeper than prepared for).

### 5.9.3. Groups View

#### Concept

A **Group** is a set of users (the group members).

In Automation Engine, **Groups** make it easy to organize and manage users.

When a group receives certain properties (for example the right to administer the server and/or a combination of **roles**), then those properties implicitly get propagated to all of its members.

When Automation Engine is initially installed on a new system (so not when upgrading),

- a default group **Administrators** is created. Its members are by default granted the right to administer Automation Engine.
- a 'getting started' administrative user is created and automatically added to this group.



**Note:** User groups in Automation Engine have, since v20, no correlation with Windows groups.

### About Groups in the Old User model (BGADMIN, BGUSERS, ...)

When an Automation Engine upgraded to v20, this view will also show 2 new AE groups BGADMIN and BGUSERS. Their name corresponds to the local Windows groups that were always used before v20.



**Note:** If, before v20, you also created other custom groups (via the UI of Windows), then the upgrade will also have created them here as roles, not as groups, because they were just a collection of user access rights.

You can continue to use these groups. You can also choose to remove them and start creating other ones yourself.



**Note:** Automation Engine will not remove these pre-v20 BG\* groups from Windows, even when they no longer have group members. You decide when to do this yourself.

### Functionality

This functionality is available either through the top bar buttons or via a right-click after selecting one or multiple groups:

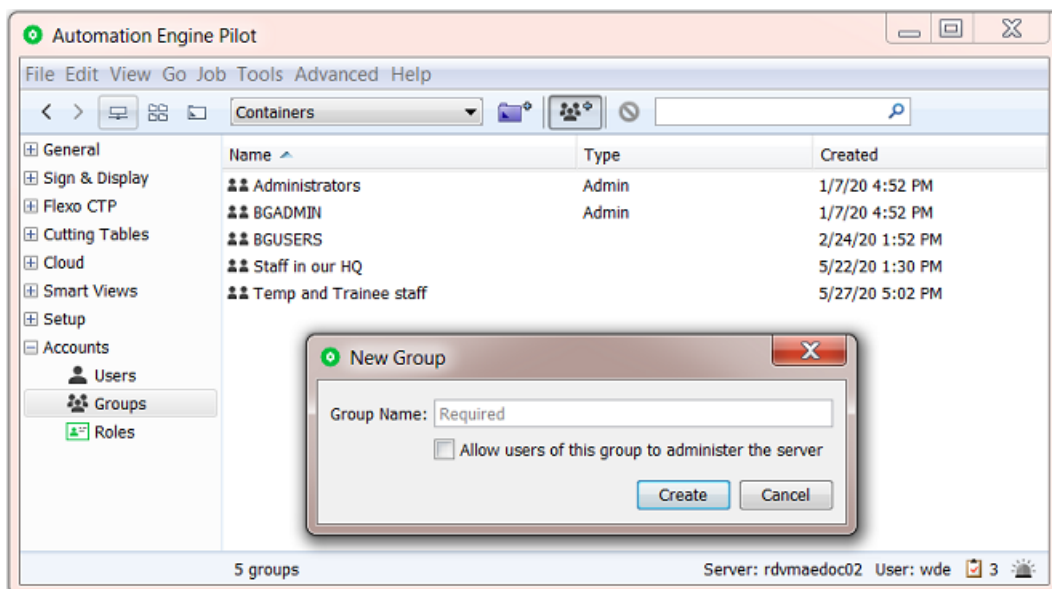

- Create a **New Group**.
  - Use the button or right-click anywhere in the view to get this option. Enter a **Group Name**.

- **Allow users of this group to administer the server:** Select this to enable members of this group to
  - create other **Users**
  - manage their access rights



**Note:** When a user is a member of several groups, its access rights are a sum of the access rights assigned to those groups.

- create **Groups**
- create **Roles**
- enable them to see the 3 Views in the Pilot of the category **Accounts**.

In the Groups view, the column **Type** will show this group as the type **Admin**.

- **Edit Group**

Double click the group to see or change its attributes:

- Allowing its members to administer the server or not
- Add / remove **Roles** to all members of this group
- Add / remove **Locations** to this group. This will filter the group members to only see data related to those locations. This tool is relevant for a company that has multiple AE sites or for a company that migrated from such a setup to a common SaaS setup. Learn more in [Locations](#) on page 220.



**Important:** To avoid problems when first starting with this type of filtering, users will also see data that has no location attribute set (yet).

- Add / remove **Members**.
- **Delete** a group.

You will be asked to confirm.

This does not remove any user accounts. It only removes the 'group' tag from users who were member of this group.

As an admin, you're responsible to keep the users, groups and roles in a healthy, meaningful state: This includes that at least one group with admin rights should remain.

## 5.9.4. Roles View

### Concept

In Automation Engine, **Roles** serve to organize and manage permissions regarding using the tools in Automation Engine.

In this version, these permissions are still limited to a set of [Access Rights](#).

A role can be attributed to an individual user but also to a group. You do that in their respective views.

Automation Engine does not come with default roles. After initial installation, this view is empty.

An example of different roles of AE users could be the roles `Prepress` and `Front-office` because users with these roles will most likely have different access rights to AE tools.



**Note:** Only Automation Engine Administrator users can see this or any view of the category **Accounts**.

### Creating a New Role

1. Click the icon in the top bar, fill in the role's name and click **Create**.

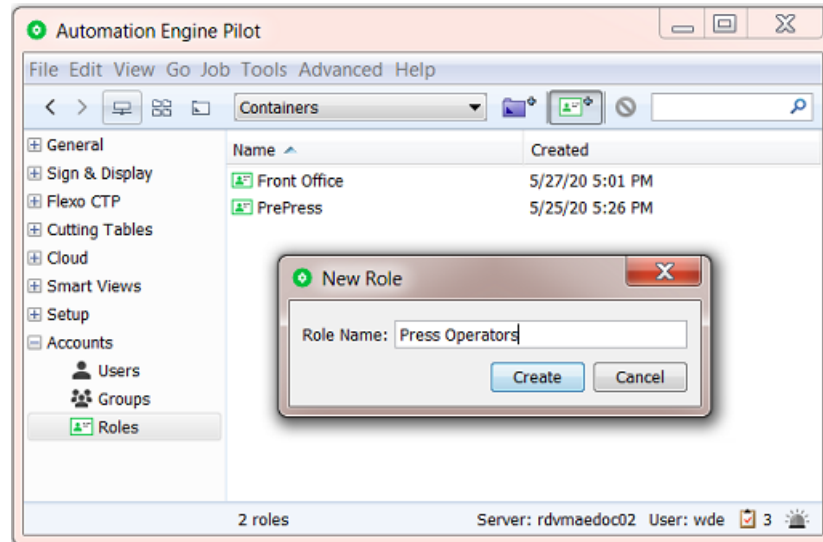

2. Don't forget to define the access rights for this role. By default none are selected. See below.

### Functionality

This functionality is available via a right-click after selecting one or multiple roles:

- **Edit Access Rights...**: This is where you select access rights for users with this role. Learn about the various access rights in [Access Rights](#) on page 157.
- **Rename**: To rename a role.
- **Delete**: To delete the selected role(s). You will be asked to confirm. This does not remove any user accounts. It only removes this tag from users who had this role attributed.

## 5.10. Tools Menu

**Tools** are views and dialogs that you can open in a separate window, next to your Pilot. Many of these are also available as a View, in the left pane of the Pilot.



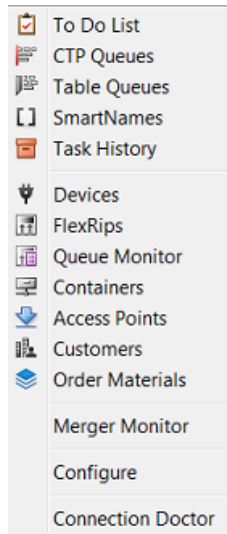

Closing the Pilot also closes all other open Tools.



**Note:** Mind that every open tool counts as a client-server connection. Depending on your licenses, you might reach the maximum.

### 5.10.1. To Do List

The **To Do List** Tool is also a View, in the category **General**. It is described [here](#).

### 5.10.2. CTP Queues

The Tool **CTP Queues** is also a View in the category *Flexo Views* on page 138. It is described in the chapter *Flexo CTP Device Workflow* on page 1482. Find a direct link [here](#).

### 5.10.3. Table Queues

The Tool **Table Queues** is also a View in the category Cutting Tables.

Learn more in the chapter [Kongsberg Production Workflow](#) on page 1565. Find a direct link [here](#).

### 5.10.4. SmartNames

The **SmartNames** View and Tool is documented in the dedicated chapter [SmartNames](#). Find a direct link [here](#).

### 5.10.5. Task History

To keep your Tasks view manageable, we advise to clean up the list of tasks. If you do not want to keep some tasks, you can delete them. If you want to keep certain tasks or tickets for later use, you can add them to the **Task History**.

There are 2 ways to have finished tasks move to the Task History:

- In the Pilot, select one or multiple tasks (maybe after first setting a filter) and can click on  to move it to Task History.
- Tasks can also automatically move to this tool by using the **Task Cleanup Rules** (in the **Configure panel > AE Database > Tasks**). You can there define which ones should automatically move to Task History. Learn more in [Task Cleanup Rules](#) on page 178.

To view the history, choose **Tools > Task History**. Initially none are shown. You only see tasks after clicking **Apply** on a chosen **Search** filter (or press **Enter**)

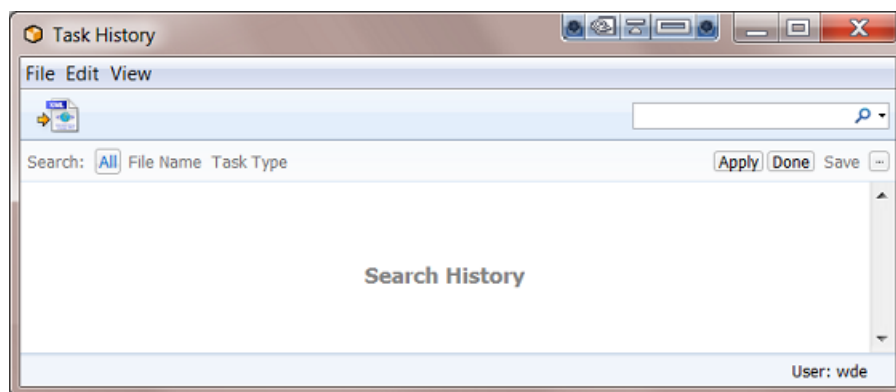

The Task History has a lot in common with the Tasks View. It lists all 'moved' tasks which you can relaunch, view and save.

You can archive entries in the Task History which you can restore later (learn more in [Why and How To Archive parts of this History](#) on page 167). You can make XML reports of the tasks and use them to bill your customers.

The Task History panel has three parts:

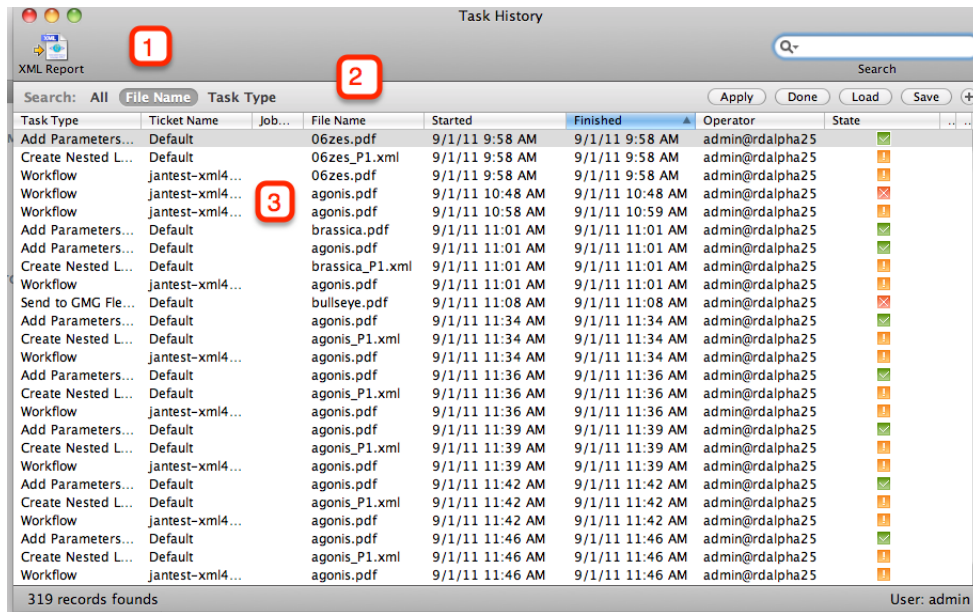

1. Task History XML Report
2. Task History Search options
3. Task History List

## Task History Menus

### File Menu

- **Open Task:** opens the ticket used for the selected task.
- **Export XML Report...** Writes a report of the current selection. This XML report contains task name, ticket name (whether or not the ticket was modified), the Operator, when it started, when the task ended, Status, Priority, job folder...
- **Archive...** It is possible to archive the data in the database to an XML file. This allows you to put the file on CD or store it somewhere else.
- **Import Archive...** Restores the data in the selected XML file in the database. A browse window pops up, browse to the archive.XML and click OK. The archive will be restored.
- **Restart History Server** This will shut down the History Server and reboot it.
- **Close Window** [Ctrl + W] Closes the window. If only one window is left, this is disabled (use Exit, to close the last window).

### Edit Menu

- **Select All** [Ctrl+ A] Selects all entries in the table.

### View Menu



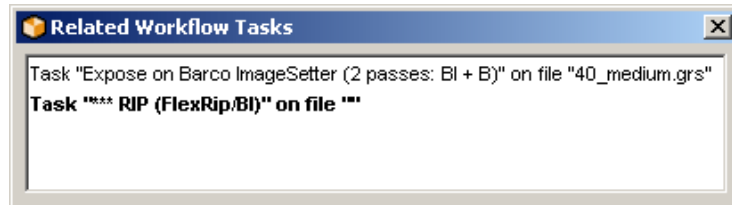

- **Columns:** define which columns you want to see, for more information, please refer to the section on [Columns](#).
- **Customize Current Filter:** Please see [filtering](#).

-  **Manage Views** [Ctrl + Shift + F] Here you can save the View Settings or select a previously created view.
- **Related Workflow Tasks:** Some tasks are part of a workflow, use this function to get a list of related tasks.



- **Stop** [Escape] This cancels the current database query and lets you set up a different specification.
- **Refresh** [F5] Perform another database query with the current settings.

**Task History Toolbar**

-  Open Task: opens the selected task.
-  XML Report... Writes a report of the current selection. This XML report contains task name, ticket name (whether or not the ticket was modified), the Operator, when it started, when the tasked ended, Status, Priority, Job folder...
-  Opens the Filter Settings dialog. Please see [filtering](#).
-  Views: use the drop-down list to select 'Manage Views...' or an already defined view.

**Filter**

Filter Settings allow specific modification of the way the Tasks View is filtered. There are five tabs.

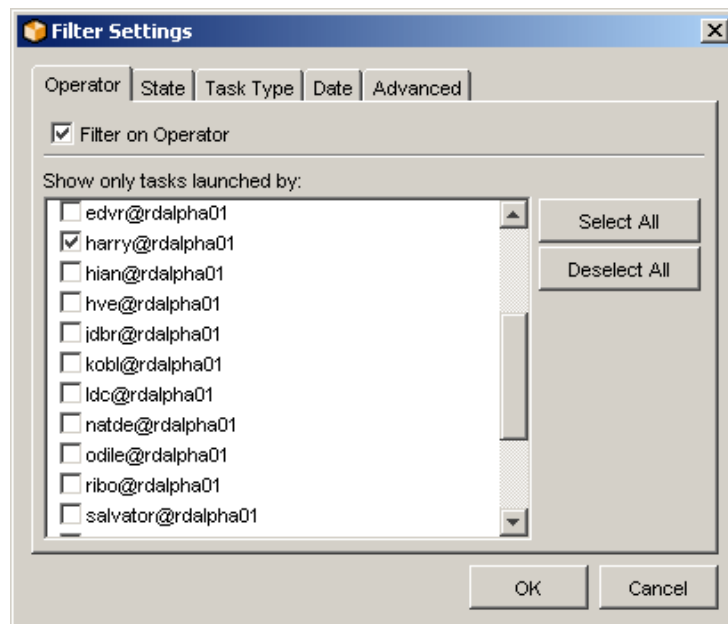

- **Operator:** Define the filter according to the Operator. Tick the ones you want to monitor.
- **State:** Define the filter according to the Status of the task. Just tick the ones you'd like to view.
- **Task Type:** By default, the Tasks View will show all tasks launched, but you can modify the filter in such a way that the Tasks View shows nothing but the type of tasks you are interested in.
- **Date:** Define the Filter according to date and time.
  - in a given time window (between [ date and time ] and [ date and time ])
  - during the previous X hour(s)
  - during the previous X day(s)
  - during the previous X month(s)
- **Advanced:**

The Advanced Filter settings allow for precise queries.

Click **'New'** to define a rule. The setup is easy. You define a rule that shows X containing a certain string.

### Task History List

The Task History list looks a lot like the [Tasks View task list](#).

The list lists all tasks that have been moved from the Tasks View to Task History. You define what you want to see. You can define the number of columns (see [View Menu > Columns](#)), you can click the head of a column to get the list to sort the way you like it, and you can filter the entries (see [View Menu > Filter](#)).

Task Type	Ticket N...	Job Name	File Name	Started	Finished	Opera...	State	Order ID	Subor...
Export to PDF ...	PDFX-3*	TFW_Out...	Sanity_2...	12/23/05 ...	12/23/05...	tfw_out...	✓	TFW_O...	
Export to PDF ...	PDFX-1*	TFW_Out...	Sanity_3...	12/23/05 ...	12/23/05...	tfw_out...	✓	TFW_O...	
Create Report...	TFW_rep_...		EG_exter...	12/23/05 ...	12/23/05...	TFW_Br...	!		
Export to PDF ...	PDFX-3*	TFW_Out...	Sanity_2...	12/23/05 ...	12/23/05...	tfw_out...	✓	TFW_O...	
Normalize Pos...	Default	TFW_Illus...	Symbols_...	12/23/05 ...	12/23/05...	kobl@r...	✓	TFW_Illu...	
Create Report...	taskinput_...	TFW_Re...	taskinput...	12/23/05 ...	12/23/05...	madl@r...	✓	TFW_R...	
Create Report...	TFW_rep_...		70004_s...	12/23/05 ...	12/23/05...	TFW_Br...	✓		
Export to PDF ...	PDFX-3*	TFW_Out...	Sanity_1...	12/23/05 ...	12/23/05...	tfw_out...	✓	TFW_O...	
Normalize Pos...	Default	TFW_Illus...	ScopeBo...	12/23/05 ...	12/23/05...	kobl@r...	✓	TFW_Illu...	
Create Report...	taskinput_...	TFW_Re...	taskinput...	12/23/05 ...	12/23/05...	madl@r...	✓	TFW_R...	
Export to PDF ...	PDFX-3*	TFW_Out...	Sanity_1...	12/23/05 ...	12/23/05...	tfw_out...	✓	TFW_O...	
Create Report...	taskinput_...	TFW_Re...	taskinput...	12/23/05 ...	12/23/05...	madl@r...	✓	TFW_R...	
Normalize Pos...	Default	TFW_Illus...	rgb_eps.ai	12/23/05 ...	12/23/05...	kobl@r...	✓	TFW_Illu...	
Create Report...	TFW_rep_...		70003_tu...	12/23/05 ...	12/23/05...	TFW_Br...	✓		
Create Report...	taskinput_...	TFW_Re...	taskinput...	12/23/05 ...	12/23/05...	madl@r...	✓	TFW_R...	
Normalize Pos...	Default	TFW_Illus...	OpacityM...	12/23/05 ...	12/23/05...	kobl@r...	✓	TFW_Illu...	

View: <all>      22 Records found.      User: admin

### Why and How To Archive parts of this History

Archiving serves two purposes:

- The Task History is used to make the Tasks View quicker, more user-friendly. All tasks stored in the Task History can be relaunched, it is a so called 'living archive'. As time goes by, you will end up with a Task History containing a lot of tasks that you may never want to relaunch. You can delete these tasks, but if you think that's not a good idea, you can use the Archive function. so archiving can be a part of the Task History database cleanup.
- Archiving can be used to make a backup of the Task History data for safety reasons. You archive your data frequently, not because you need the space, but because you want to store your XML archive safely elsewhere, so you can easily restore it when problems should arise.

Archiving will store all information of certain tasks in an XML file. This adds the possibility of restoring those XML archives into the Task History. So your information will never be lost.



**Note:**

Archiving only works on selected tasks.

Archiving doesn't delete the archived tasks from the Task History.

1. Select the tasks you want to archive.

If you want to archive all tasks, press CTRL + A. If you want to make a sub selection, the Task History reacts to the known shortcuts such as CTRL + click and SHIFT + click.

If you want to make an intelligent selection, and you don't want to lose time, you'd better use the [Filter](#) . You define what you want to see in the Task History (for example all tasks originating from one particular job, or handled by one particular operator, ...), click CTRL + A and you're ready to archive.

2. Click Archive (File Menu > Archive).
3. A dialog pops up, allowing you to browse to the place where you want the archive XML to be stored. Make sure to give the archive XML a meaningful name in order to avoid confusion later on. Confusion might arise if you bear in mind that the Task History also uses the XML language to write an XML report.

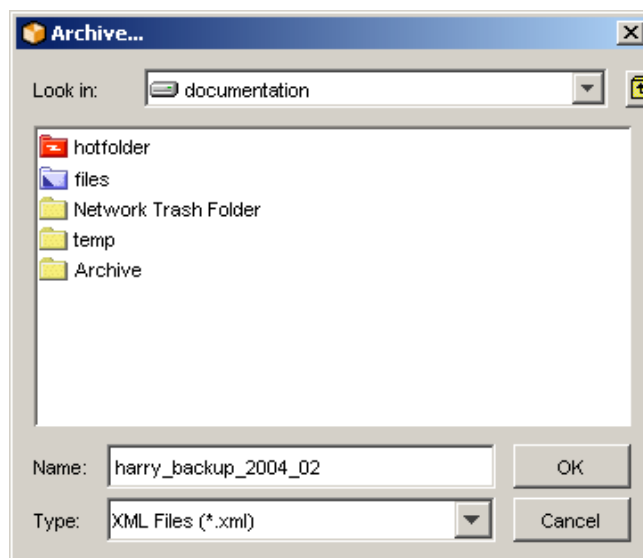

Click OK.

4. A 'Confirm' dialog pops up and asks you whether or not you want to delete the archived items:

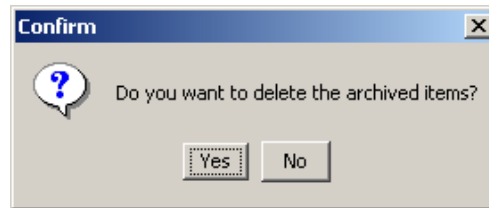

### 5.10.6. Devices

The View **Devices** is also available as a Tool in a separate window. Both are documented in the dedicated chapter [Flexo CTP Device Workflow](#) on page 1482. Find a direct link [here](#).

### 5.10.7. FlexRips

The **FlexRips** tool is also a View, in the category **Setup**. It is described [here](#).

### 5.10.8. Queue Monitor

The **Queue Monitor** tool is also a View, in the category **Setup**. It is described [here](#).

### 5.10.9. Containers

The **Containers** tool is also a View, in the category **Setup**. It is described [here](#).

### 5.10.10. Access Points

The **Access Points** View and tool is described in the chapter [Integrating with External Systems](#). Find a direct link [here](#).

### 5.10.11. Customers

The **Customers** tool is also a View, in the category **Setup**. It is described [here](#).

### 5.10.12. Order Materials

The tool **Order Materials** is also a View in the category Setup.

Learn more [here](#).

### 5.10.13. Merger Monitor

If you use a "RIP to ..." FlexRip-ticket to output on a device that has been configured to work with merge queues, you can monitor the merging activities.



**Note:** This merge tool was mainly used for Computer To Film devices.

Start the **Merger Monitor** by selecting 'Merger Monitor' from the **Tools** menu.

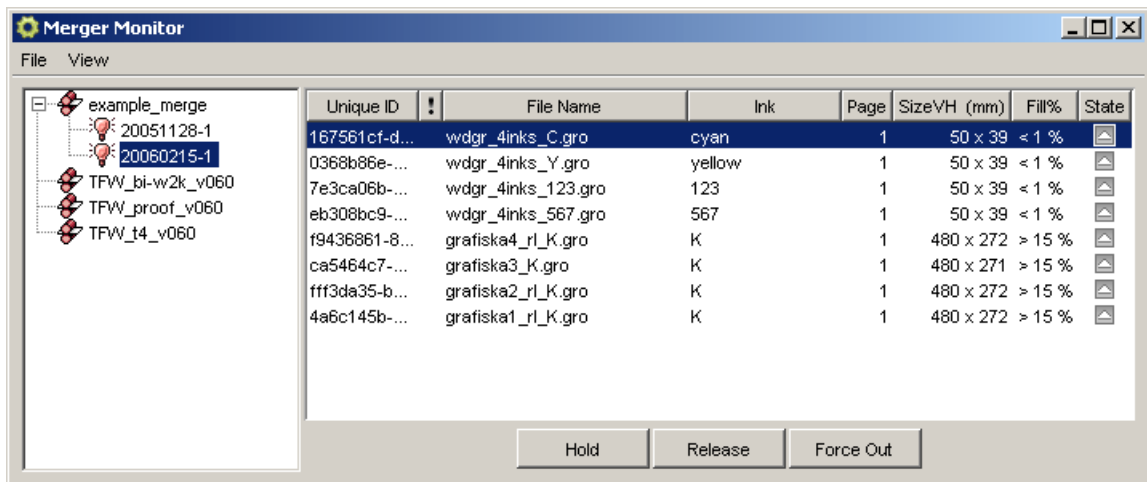



The Merger Monitor consists of two panes.

The **left pane** lists all devices  on which files have been merged or are currently waiting to be merged. In the example above there's one device listed **example\_merge**. Every device on which something has been merged stays listed until the server is rebooted.

Select a device to see what is in its **merge queue**. Files that are to be merged are assembled in **pools**.

A **pool** is a group of files with the same characteristics (same plate size, negative or positive, ...). These characteristics are defined by "**extract restrictions**" (in more recent features this is named 'Grouping Keys'). For example: jobs with a different Dot Gain Compensation setting will not be merged together. They will not belong to the same pool.

Some of these restrictions depend on the setting in the **General tab** of the ticket you use.

1. **VDistortion** and **HDistortion**: Files must have the same vertical and horizontal distortion before they can be in the same pool.
2. **Reverse** : Files have to be reversed in the same way before they can be in the same pool.
3. **Mirror** : Files have to be mirrored in the same way before they can be in the same pool.
4. **Dot Gain Compensation**: Only files with the same Dot Gain Compensation belong in the same pool.



The other restrictions are defined in the **Output** tab of the ticket you use.

1. **Conf**: Files need to have the same plate size before they can be in the same pool.
2. **Output path** and **Output File Name**: Files with different Output paths or Output File names will end up in different merge pools.
3. **Resolution**: Files need to have the same resolution before they can be in the same pool.
4. **Compression**: Files need to have the same compression before they can be in the same pool.

Notice that **example\_merge** has two pools  : 20051128-1 and 20060215-1. When you select the device, but not a pool, you get an overview of all files waiting to be merged. In order to visually indicate that files belong to different pools they have a different background color. White and gray are used consecutively.

The **right hand panel** provides detailed information on files in the merge queue.

- The **Task ID**
- **Priority**: this is the priority you defined in the Expose On ticket, not the priority of the task.
- The **Name** of the Job/File
- The **Inks** you are exposing, you defined them in the **Expose On ...** ticket.



**Note:** There are two ways in which the inks are listed. C&M&Y&K or C+M+Y+K. They can be merged on separate films or on the same film.

- The **Page** number
- The **Size VH (mm)**





**Note:** The symbols used to indicate the size tell you whether or not the file can be rotated in the merger. <> (**154<>191**) indicate that the file can be rotated, an **x (154x191)** indicates that it cannot.

**Rotation** is an option you can set in the **Transformations** part of **General** tab of the used task ticket.

- **Fill %**: This is (Job size / Plate size)

These percentages are relative, the overall fill depends on the margins and gap as they are currently defined in your ticket. You cannot simply add the percentages to get a correct idea of the overall fill. There are all kinds of reasons why files cannot be merged together and why the fill percentage is -as a result- not yet reached.

- The **State** of the file in this **Merger** queue

A file can be **on hold**  (it's an option you can choose in the 'Expose On ticket'). A file can be **released** , but that does not mean that it will be merged, it still has to wait till the fill percentage is reached. You can **Force** a file **out**  of the Merger queue. The forced out file will take as many files possible with it, if they have a 'release' status.

## 5.10.14. Configure

### Overview and main functionality

Use the Configure tool to connect to a variety of devices and applications, and define general Automation Engine server settings preferences.

To start, sign in to a Pilot and go to **Tools > Configure**.

#### To Define Settings in Configure

1. Select the category in the left pane.
2. Go to **File > New**.
3. Click on the default name that appears for that new item and wait a moment till the cursor allows you to change the name.
4. Define your settings on the right.
5. Go to **File > Save**.



**Note:** (Windows) shortcuts:

- 'Insert': to add an item.
- 'Delete': to delete the selected item.
- 'F2': to rename the selected item.

### ArtiosCAD Servers

To configure a new ArtiosCAD Server in Automation Engine, go to **Tools > Configure > ArtiosCAD Servers**.

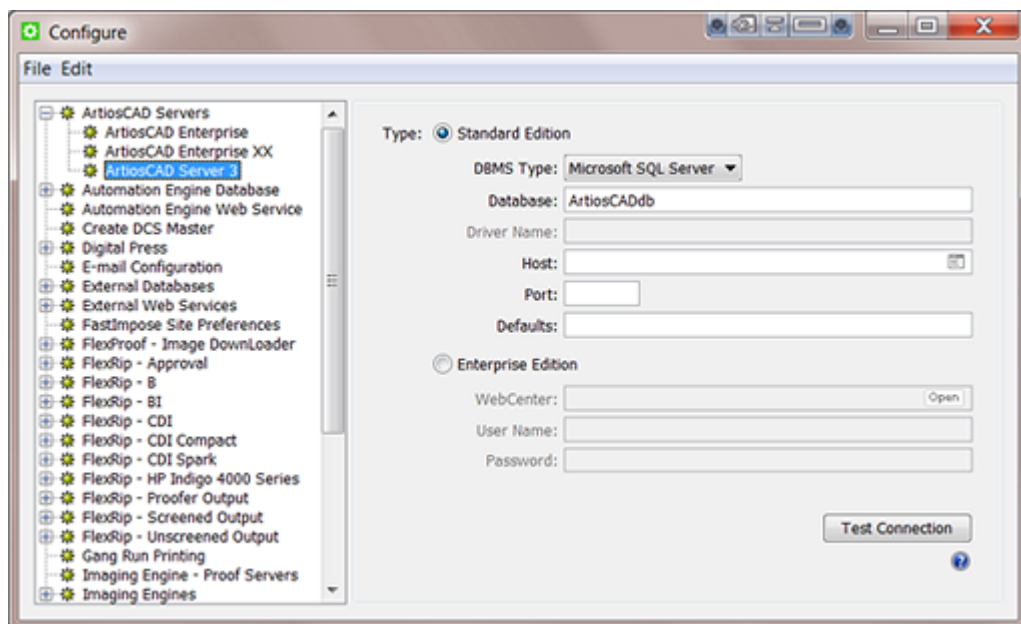



**Note:** When the database is of the **DBMS Type** "Microsoft SQL Server", you can press  to select the **Host** and Instance from a list.

### How to configure a Standard Edition ArtiosCAD Server

1. Set up the ArtiosCAD Database Settings

a) When the ArtiosCAD database is installed on a **Microsoft SQL Server** database engine:

1. **DBMS Type:** Select **Microsoft SQL Server**.
2. **Database:** Enter the **Name** of the ArtiosCAD database. Default is `ArtiosCADdb`.
3. **Host:** Select or enter the name of the database host. When the name of the SQL Server Instance for ArtiosCAD was not deployed with the default unnamed instance, then also add the name (typically `<ArtiosCAD Server>\Esko`).
4. **Port:** When not using the default port, enter the port number.

b) When the ArtiosCAD database is installed on an **Oracle** database engine:



**Important:** The **Oracle Client Software** (*ODBC: Additional libraries for enabling ODBC applications*) needs to be installed on the Automation Engine Master and its Assistants. When not installed, the [Create CAD Report from XML task](#) will not be able to connect to the Oracle ArtiosCAD database.

1. **DBMS Type:** Select **Oracle**.
2. **Service name:** Enter the name of the Oracle TNS, for example `Oracle X.E.`
3. **Driver name:** Enter the name of the Oracle database driver.



**Note:** This name can be found in the Drivers tab of the ODBC Control Panel (`%systemdrive%\Windows\SysWoW64\Odbcad32.exe`) after installation of the Oracle Client Software.

4. **Host:** Enter the name of the database host computer.
5. **Port:** Enter the port number when you are not using the default one.

2. **Defaults:** Enter the location of the ArtiosCAD Defaults.

This path should be a **file:** URL, pointing to the ArtiosCAD Defaults. For example: `file://MyMachine/ArtiosCAD`.

Leave this Defaults field blank to use the ArtiosCAD Defaults installed on the Automation Engine Master or on an Assistant.

The Automation Engine server should be able to reach this folder, and the service account of the BGMD Service should have read access to the folder. This account by default is the System Account "BGSYSTEM" (but can be changed in [the System Account page](#)).



**Note:** ArtiosCAD Defaults are **version specific**. The version of ArtiosCAD hosting the Defaults must match with the version of CADX installed on the Automation Engine computer (Master and its Assistants).

When no ArtiosCAD Defaults location is specified, the [Create CAD Report from XML task](#) will use the ArtiosCAD Defaults installed on the Automation Engine computer (Master and its Assistants).

3. Click **File** > **Save**.

4. Click the **Test Connection** button to test the connection to the ArtiosCAD Database and the ArtiosCAD Defaults.

When all is well, you will get a message stating "Connection to the database OK".

Otherwise, you will get an error message:

- when the Automation Engine server can't connect to the database.
- when the Automation Engine server can't get info about the Defaults location. If so, check if the location exists, and if it can be reached from the server.
- when the Defaults location is not a folder.

### How to configure an Enterprise Edition ArtiosCAD Server

1. Select **Enterprise Edition**.
2. **WebCenter:** Enter the WebCenter site location, typically `http://<WebCenterServerName>/WebCenter_Inst`.
3. Click **Open** to open the specified site in your default browser.
4. Enter the **User Name** and **Password**.
5. Test the connection by clicking the **Test Connection** button.

You will get a message stating "Connection to the database OK", or get an error message when the Automation Engine can't connect to WebCenter.

### Automation Engine Database

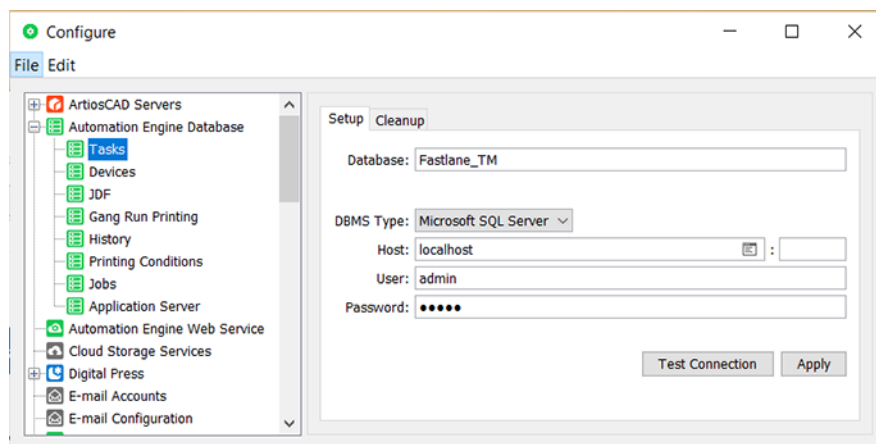

These databases are set up automatically when the Automation Engine server software is installed (and their license is present). In this item of the configure panel, you can see their settings, make changes and test their connection.



**Attention:** In the [AE Server Admin web page](#), in the section [Databases](#), you can also manage databases, but there to make changes after an installation and without the use of a Pilot.

### Standard and Alternative Database Server Choices for Automation Engine

Before going in more detail, we here summarize the choices you have:

- **Standard installation with the standard database server (type).**
  - A standard installation of Automation Engine will install and use an **SQL Server Express** version.
- **In case you need a (much) more powerful database server.**
  - In case you have reached the limits of the **SQL Server Express** version, you can make Automation Engine work with a full **SQL Server** version. Learn more in [Databases](#).
  - Commercial printers with heavy loaded page workflows, can also choose to use an **Oracle** database, but only for their Application Server database.
- **Or use a small test database server for other special cases.** You can use an **"Embedded"** database:
  - In exceptional cases on advise of Esko Support, for example to help solve a database problem.
  - When first installing Automation Engine, to avoid that the installation installs the default SQL Server Express, of which you know you will not use it anyway (because you already decided you will use a full SQL Server). This avoids having to uninstall that SQL Server Express version and other peripheral software.



**Important:** For more information on your options when installing Automation Engine, check the dedicated [Installation Guide](#) on page 1982.

### Generic setting (Setup tab): DBMS Type

We here describe the general settings of the **Setup** tab in the configuration of the various databases. See their own pages for any specific settings.



**Note:** DBMS stands for "Database Management System".

### DBMS Type "Microsoft SQL Server"

These settings will be filled out correctly after installation of the server software. You can however change these settings.

Here is an example of the **Jobs** database:

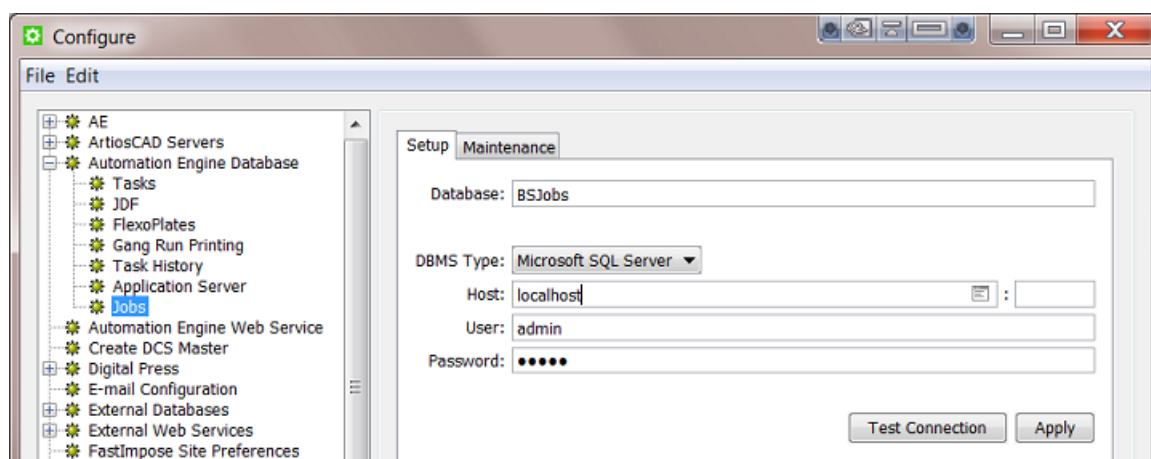

- **Database:** Keep the default name or, before initial use of this database, enter a different name.
- **DBMS Type:** Select the driver type **Microsoft SQL Server**.



**Important:** This type is valid both for an MS SQL Server Express as for a full MS SQL Server.

- You can press  to select the **Host** and **Instance** from a list. Here is an example of such a list:

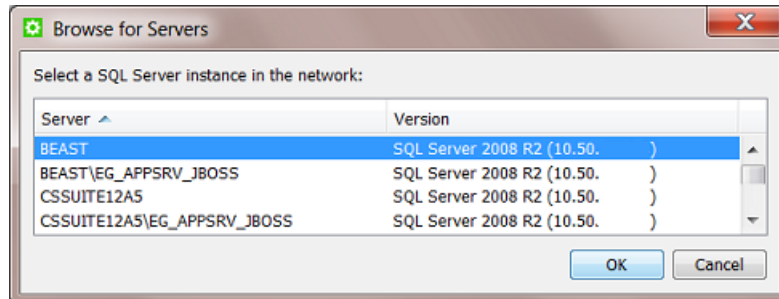

- Enter a correct **User** name and **Password** to access that database.

### DBMS Type "Embedded" (only for test purposes)

This **Embedded** database engine is built into Automation Engine's installation kit.



**Attention:** This **Embedded** database type is not suitable for production use! Embedded databases can only be used in very low volume and low load (test) circumstances. Production level performance and stability may not be expected with this configuration. For production use, choose a Microsoft SQL Server (or, in case of the Application Server database, Oracle). Failure to do so may, in a worst case, result in data loss or data corruption.

- When the DBMS type is **Embedded**, set the **Folder** to point to the location where the embedded database will be kept on disk (for example "C:\Esko\bg\_data\_database\APPSRV" for the Application Server database).
- Enter a correct **User** name and **Password** for the database user to create or access this database. Enter a blank user name and password when the database or the database user has not yet been created, except for the Application Server database, in which case you need to use the user name "sa".

### DBMS Type "Oracle"

Learn more about using Oracle as engine for the **Application Server** database in the chapter [Pre-Install IT Requirements](#), in the page [Oracle as Database Server for the Application Server component](#) on page 1969.

### Generic setting (Setup tab): Testing the Connection and Applying the Config

Each database configuration has in its **Setup** tab two buttons: **Test Connection** and **Apply**.

#### Testing the Connection

Click the **Test Connection** button to perform these checks:

- Is the database management system running?** These are possible error messages:
  - When the instance is not running or accessible, you get Could not connect to the SQL Server instance.

- When the user name / password is wrong or when there is no permission to connect, you get `Trying to log in failed`.
- When the host is not running or not reachable (wrong name), you get `Unknown database host`.
- When wrong information was typed in, you get `No such instance`.
- **What is the database system version?**
  - An error is shown when `The database system version is not supported (anymore)`. For example: you selected an SQL Server 2000.
  - A warning is shown when `The database system version will soon be outdated`. For example, in version 14.1, an SQL Server 2005.
- **Is the database online?**
  - In case of a wrong user name / password or wrong database privileges, you get `Trying to open database failed`.
  - When the database doesn't exist, you get `Could not find database`.
- **What are the database user roles?**
  - When the user is not a member of required database roles, you get `Insufficient roles`.
- **What about the database system memory?**
  - The maximum server memory does not meet the recommendations. This is about the memory of the (SQL) database server. For example, in version 14.1, a server minimally needs +- 4 GB.
  - The total physical memory does not meet the recommendations. This is about the memory of the computer. For example, in version 14.1, a server minimally needs +- 4 GB.
- **Is the database system speed sufficient?**
  - You get a warning when `The connection is rather slow`. For example, in version 14.1, on average, connecting to the database system and getting version info takes more than 100 ms.



**Note:** You can find updated and detailed minimal requirements on <https://www.esko.com/en/systemrequirements>.

When all checks return an OK result, an info dialog will tell you that the **Database is online and accessible**.

### Applying the Changed Configuration

After you tested the connection, and solved any errors, click **Apply** to save and apply this setup.

When you click **Apply**, Automation Engine restarts parts of its software and then starts accessing the database using the new settings.



**Important:** When you do not click **Apply**, but only **Save** these (and other) changes in the Configure tool, then the changed settings will only be applied the next time the (full) Automation Engine server software is restarted.

## Tasks

### Concept

Launched tasks are stored in a database with a default name `FastLane_TM`.

You can see what exactly is in this Tasks database via the 'Tasks' view in the Pilot.

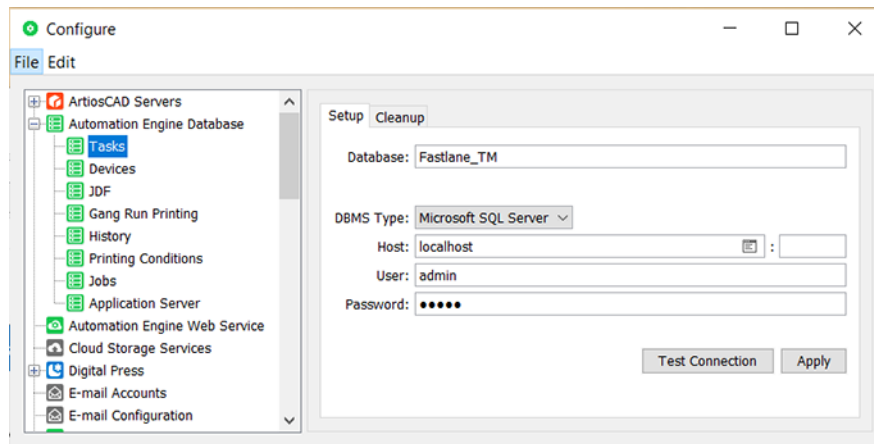

The settings in the **Setup** tab are generic and described in the [DBMS Type](#) and [Testing and Applying the Configuration](#).

### Cleanup

There are 2 ways to clean up this database: The task is in this database until

- the task is deleted (using the Pilot)
- the task is **moved to history** (a different database that also contains other historical info, see also the other database topic '[History](#) on page 180'.

Learn more below in [Task Cleanup Rules](#) on page 178.

### Task Cleanup Rules

In the Pilot, you can not keep all your finished tasks in the Tasks view forever ; this would slow down Automation Engine and eventually fill up the tasks database.

You have the choice to

- **remove** them. In the Pilot tasks view, make a selection, press the **Delete** button and confirm.
- or **move them to** the [Task History](#) on page 164 tool.

You can define **Cleanup Rules** to automate this cleanup.



**Attention:** Only finished tasks (those in the state `Successfully done`, `Done with warning`, `Workflow failed`, `Failed`, or `Cancelled`) can be either moved to Task History or be deleted. The cleanup rules mechanism will ignore tasks that are still running or waiting. Finished tasks that are part of a workflow that is still running or waiting will be ignored too.



An example of **Task Cleanup Rules**:

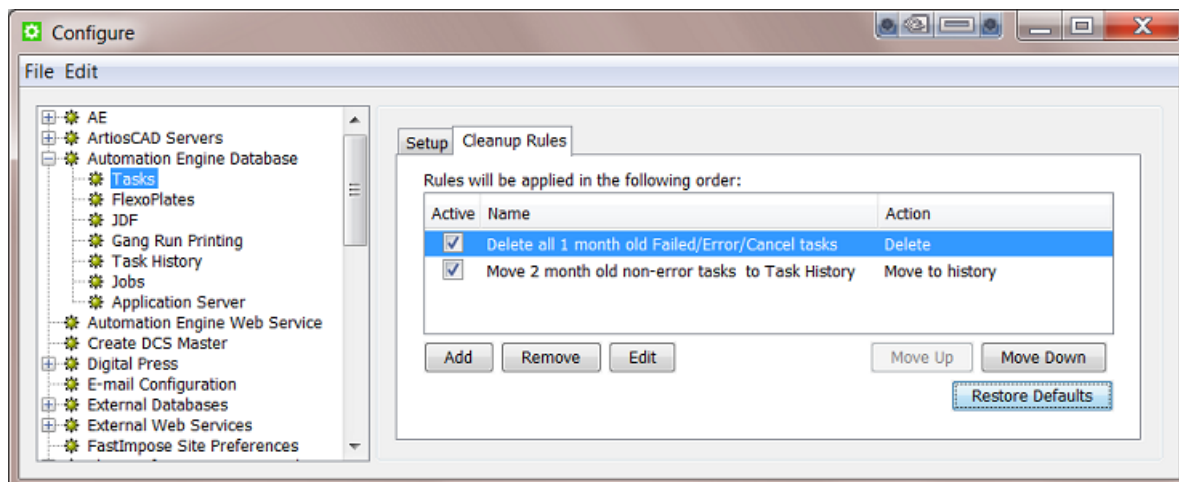

The way to create these rules is very similar to making filters in many Pilot Views. You can learn how to do this from a similar example used in [Job View Filters](#) on page 542.



**Attention:** The rules are executed from top to bottom, so their order is very important. You can use the **Move Up / Move Down** buttons to make sure they are executed in the most productive order. For example: you typically first want to delete tasks and then start moving the rest to history.

## Devices

This database stores all the information that is shown in the Devices view, both for [Flexo devices](#) and [Cutting Tables](#).

By default, this database uses the same database as for **Jobs**.

- **Tab Setup:**

Learn about these generic settings in the above pages on [DBMS Type](#) and [Testing and Applying the Configuration](#).

- **Tab Cleanup:**

Define after how many days you want to **Automatically delete records** in all the device-related databases. This deletes

- records in databases that are used in these Pilot Views:
  - (CDI workflow): [Press Plates](#), [Press Plate Sets](#), [Merged Plates](#).
  - (Kongsberg workflow): [Sheets](#) view and (Sign & Display) [Orders](#) view.

The time you specified is calculated after the item's **Finished** date.

- It also deletes the files in the Media Root Folder (see below) older than that specified time.

- **Tab Advanced:** Browse to specify the **Media Root Folder**.

When a job is finished on a Kongsberg table, a new item is added to the Kongsberg [Sheets view](#). The JDF and cut file that this (database) item refers to are stored in a unique subfolder of this Media Root Folder.



**Note:** Files related to the CDI Plate Merger are stored in the folder specified in [the Configure item "Plate Merger"](#).

## JDF

This database is used when Automation Engine sends or receives JDF commands. For example when jobs are created via JDF or when WebCenter sends workflows to Automation Engine (via JDF).

By default, this database uses the same database as for **Jobs**.

The settings in the **Setup** tab are as described in [Generic setting \(Setup tab\): DBMS Type](#) on page 175 and [Generic setting \(Setup tab\): Testing the Connection and Applying the Config](#) on page 176.

## Gang Run Printing

This database is used by the [Gang Run Printing mode](#).

By default, this database uses the same database as for **Jobs**.

The settings in the **Setup** tab are as described in [Generic setting \(Setup tab\): DBMS Type](#) on page 175 and [Generic setting \(Setup tab\): Testing the Connection and Applying the Config](#) on page 176.

## History

### Various Historical Data

This database contains various types of data:

- **Task History** data: Tasks that were not deleted but moved to this separate database. Learn more in [Task History data](#) on page 180.
- Historical system configuration data. Learn more in [System History - Configuration data](#) on page 180.

### Setup

The settings in the **Setup** tab are as described in [Generic setting \(Setup tab\): DBMS Type](#) on page 175 and in [Generic setting \(Setup tab\): Testing the Connection and Applying the Config](#) on page 176.

### Cleanup

Also this database offers ways to clean it up. Learn more below in [Cleanup](#) on page 181.

### Task History data

The **Task History** is a tool that stores old tasks. You keep them there because you may want to look up the settings they used or to relaunch them on same or other files.

The Task History tool is opened from the Pilot's [Tools menu](#).

Learn more in [Task History](#) on page 164.

### System History - Configuration data

These are the events tracked and shown in the admin web page [System History](#) on page 2008.

### Cleanup

In case this database is filling up or when you experienced that there is need to keep data of a certain age, it is advised to clean up.

- **Automatically delete tasks older than X days.** Choose this for an automatic partial cleanup of the data offered in the Task History tool .
  - **Clear All Tasks in History.** This deletes all tasks data in this database. You will be asked to confirm.
- **Automatically delete system history older than X days:** This serves to clean up the data that is shown in the admin web page [System History](#).

### Printing Conditions

This database is related to the **Print Control Wizard**.

#### What is the Print Control Wizard?

The Print Control Wizard is a tool that helps you optimize your print quality.

Based on your **exact printing setup**, your current print quality and the **standard** you want to print towards, the Print Control Wizard will calculate the **best possible screens and curves** that you can use to achieve great results on press.

This will help you avoid common problems, for example a lack of smoothness in the transition from shadows to solids, or from highlights to paper, and will make getting good printing quality time after time **easier**.

#### What is a Printing Condition?

The Print Control Wizard will guide you in creating a printing condition. This printing condition will:

- describe your exact printing setup (press, substrate, inks, plate, etc.) and the way it prints,
- include the standard you want to print towards (an ISO standard, linear printing...),
- result in the best possible screens and curves to achieve the quality of that standard with your printing setup.

Learn more about this tool and its installation in [the documentation of Print Control Wizard](#).



**Note:** This tool is present on the installation DVD of **Imaging Engine**.

### Jobs

#### Setup

By default the database used for jobs is named `BSJobs`.



**Note:** The `BS` in the name `BSJobs` refers to an old Esko server software application.

The settings in the **Setup** tab are as described in [Generic setting \(Setup tab\): DBMS Type](#) on page 175 and in [Generic setting \(Setup tab\): Testing the Connection and Applying the Config](#) on page 176.

**Cleanup**

**Dangling Jobs** are active Automation Engine **Jobs** that have a link to a job folder that is not there, probably because the folder was (re)moved or renamed.

Normally, each active **Job** relates to one job folder on disk. But it does happen that a user moves or deletes a job folder, for example via Windows Explorer or Macintosh Finder. This causes discrepancies between the information of that Job in the **Jobs** database and the actual situation on disk. Removing such dangling Jobs brings the database back in sync with the reality on disk.

Click **Remove** to make the database check, for each Job, whether or not their job folder still exists. You will be asked to confirm. When that folder does not exist, the Job will be removed from the Automation Engine database.



**Note:** This implies that instead of deleting jobs via the Pilot, you are able to delete Jobs by deleting the corresponding folder and then manually cleaning up the dangling Jobs here.

**Application Server**

This database is used when you use the Pilot Views that are valid for page workflows: **Pages, Proofs** and **Plates** (category **Commercial Print**).

By default, this database uses a database named *fasttrack*.

The settings in the **Setup** tab are as described in [Generic setting \(Setup tab\): DBMS Type](#) on page 175 and [Generic setting \(Setup tab\): Testing the Connection and Applying the Config](#) on page 176.

This database can also use the DBMS Type **Oracle**. Learn more about using Oracle as engine for the **Application Server** database in the chapter [Pre-Install IT Requirements](#), in the page [Oracle as Database Server for the Application Server component](#) on page 1969.

**Automation Engine Web Service**

This setup is documented in the chapter [Integrating with External Systems.](#), as part of the setup of a [Web Service Access Point](#).

**Cloud Storage Services**

This is where you configure cloud storage destinations that the [Upload to Cloud Storage](#) task can upload files to and where a [Cloud Storage Access Point](#) can download files from.



**Note:** Any form of SSO (as supported by some Cloud Storage services), is here not supported. Access Points run as user 'BGSystem' on the master Automation Engine server.

**Configuring Box, Google Drive or OneDrive**



**Note:** For Amazon S3, see the separate page [Configuring Amazon S3](#) on page 188.

Follow these steps to create an account:

1. In **Tools > Configure > Cloud Storage Services**, click **Add** and select the provider (Box, Google Drive or OneDrive).

When selecting OneDrive, an extra dialog first asks to indicate the type: **OneDrive for Business** or **OneDrive Personal**.

2. The **Add ... Account** dialog of the selected provider dialog informs you on the process and asks to sign in to that provider.



**Attention:** When your internet browser is already open, an account could already be logged in to that service. To make sure you sign in with the right account, close your browser first.

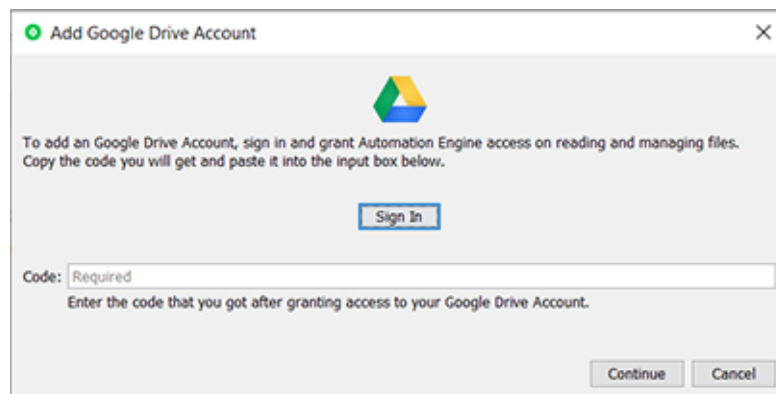

3. Click **Sign In**. Your browser opens a page asking permission for Automation Engine to view and manage files on that storage. When your browser does not auto-remember your credentials, it will first ask you to sign in to that provider.
  - Here's an example using Google Drive where your browser might remember an account or propose the one that you are already signed in with:

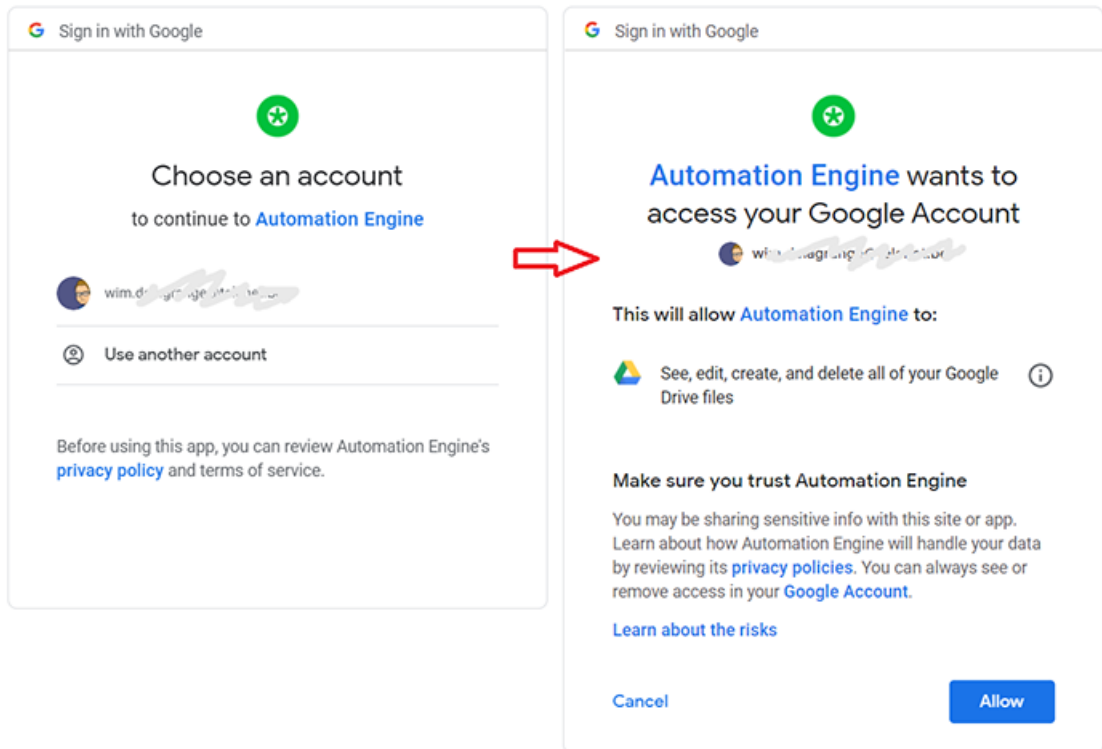

4. Click **Allow** to continue. The provider now grants access to the account and calculates a unique code. This code is displayed as part of the URL that the browser is then redirected to.

- For **OneDrive Personal**, the URL that the browser is redirected to results in an empty web page like this:



- For **OneDrive for Business**, the configuration is similar to the one when setting up [OAuth2 level mail accounts](#).. Learn more in the separate page [Configuring OneDrive for Business](#) on page 186.
- For **Box**, the URL that the browser is redirected to brings you to a dedicated web page on Esko's web site:

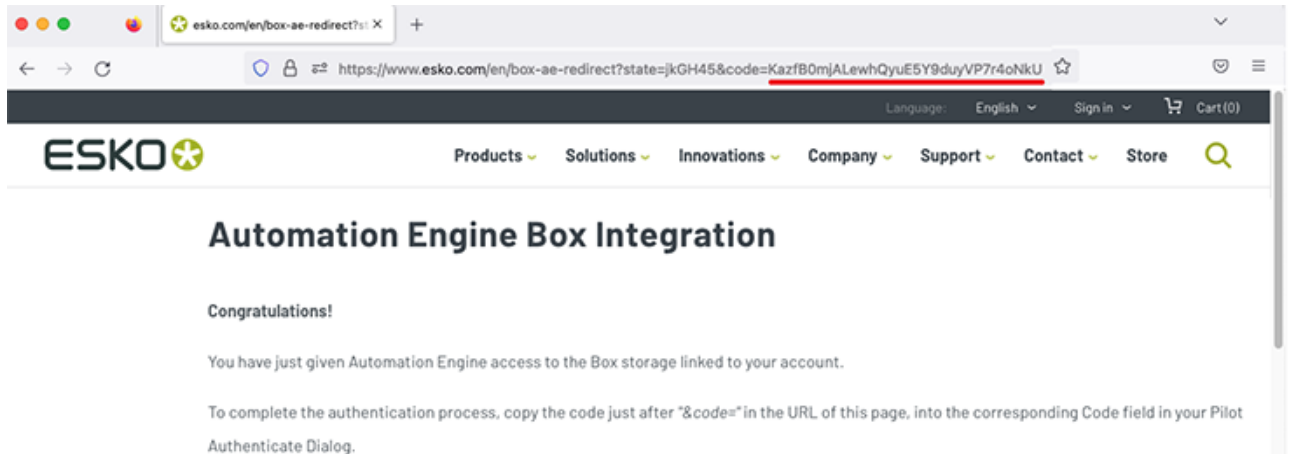

- For **Google Drive**, the URL that the browser is redirected to is not supposed to be valid, so your browser is expected to be unable to connect. The URL displayed however does include the code that we need.

Depending on your web browser, the web page displayed may look like this:

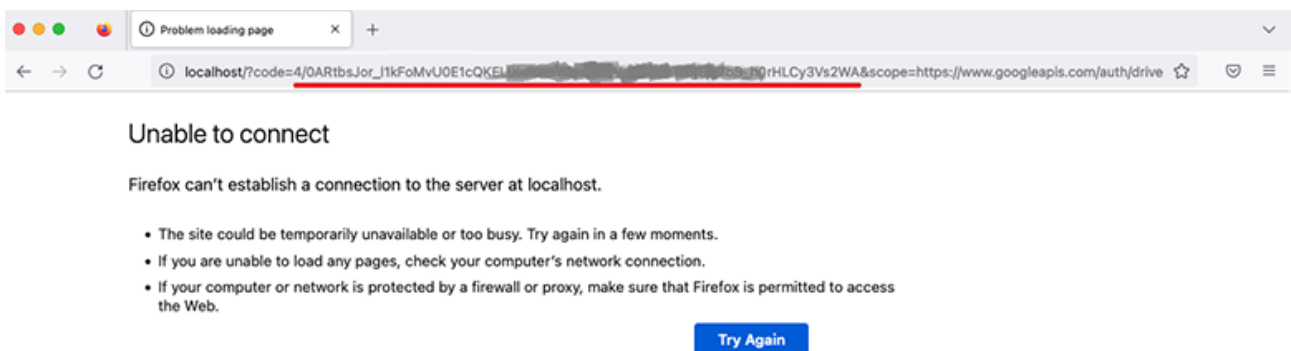

**Note:** Because of the redirect to `localhost`, make sure that, on the computer you're using the Pilot from, no web server is running that could otherwise intercept web traffic on port 80. For example, this could be the case when you manage web content on that computer and would test this content for correct behavior on a local web server hosted on that computer.

**Note:** In previous versions of Automation Engine, the browser was redirected to a dedicated web page on the Google web site which allowed to copy the code. This so-called out-of-band (OOB) redirection flow was however discontinued by Google since early October 2022, hence the different approach now.

5. Select the part of the URL that represents the code and copy it (`Ctrl-c` / `Cmd-c`) to your clipboard.

**Tip:** You may also try with copying the complete URL. In most cases this will work as well.

6. Go back to the **Add <provider> Account** dialog and paste the code or full URL in the **Code** field (`Ctrl-v` / `Cmd-V`):

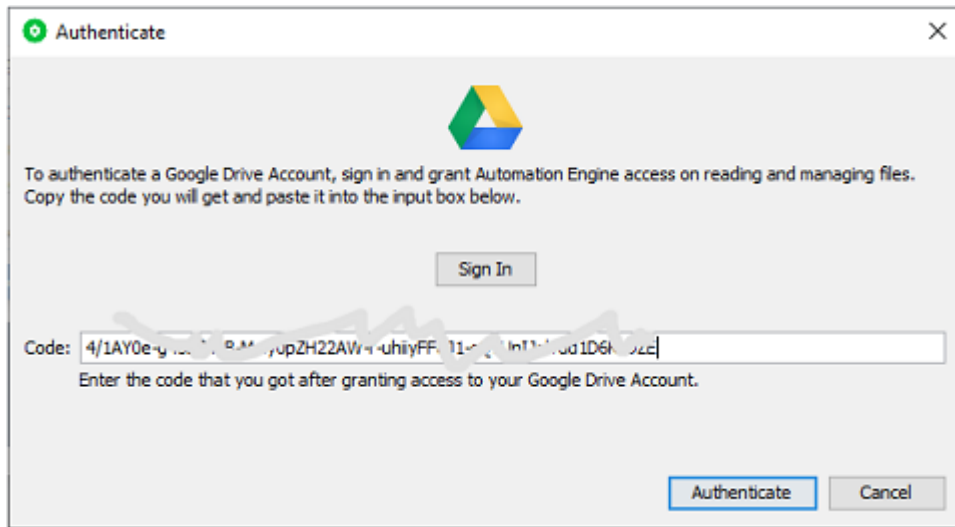

7. Click **Continue** and add an **Account Name** and **Description**.
8. Click **Create**.

This account is now ready to be used in the tools that use cloud storage services.



**Note:** You can reset the authorization for an account. This is needed when the authorisation token became invalid (it is broken, the administrator of the cloud storage deleted the site, ...). Follow these steps:

- Select the account for which you want to reset the authorization.
- Click **Authenticate**.
- In the dialog that pops up, fill in the required key(s) and press **Authenticate**.

### Configuring OneDrive for Business

Follow these steps to create an account for OneDrive for Business:

1. In **Tools > Configure > Cloud Storage Services**, click **Add**, select **OneDrive** and click **OK**.
2. In the **Add OneDrive Account** dialog, select **OneDrive for Business** and click **Continue**.



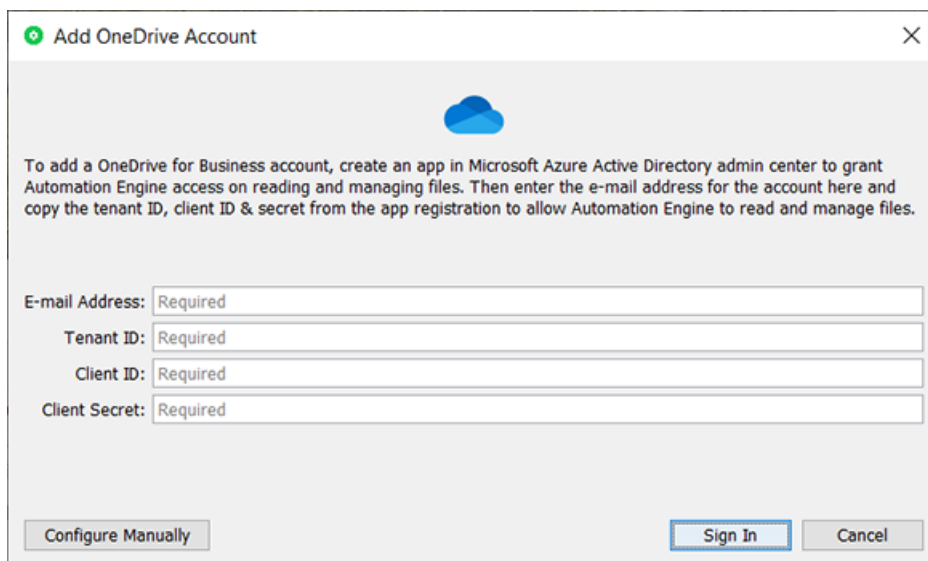

3. Follow these steps:

- a. First, in **Microsoft Azure Active Directory admin center** (<https://aad.portal.azure.com/>),
  - (check with your IT administrator to) Create an app to grant AE access on reading and managing files in OneDrive for Business. Learn more below.

- b. Then, in **Automation Engine**, in the above shown dialog, enter the **E-mail Address** corresponding to the OneDrive account you need to access. And from the app registration, copy the **Tenant ID**, **Client ID** and **Client Secret** here. Learn more below.
  - When clicking **Sign In**, a web browser opens and the user can sign in to their OneDrive for Business account. By doing so, Automation Engine can obtain a refresh token.



**Note:** The user has 3 minutes to sign in. After that period, the dialog will show an error.

- **Configure Manually:** It is also possible to manually fill in the refresh token. It is a more direct way to interact with OneDrive for Business that can offer a solution when you have problems to sign in.
- When signing in was successful (either using the web browser or by giving the refresh token manually), a next dialog asks you to complete the process by filling in an Account Name and a Description. **Account Name** and a **Description**.



**Note:** You can reset the authorization for an account. This is needed when the authorisation token became invalid (it is broken, the administrator of the cloud storage deleted the site, ...). Follow these steps:

- Select the account for which you want to reset the authorization.
- Click **Authenticate**.
- In the dialog that pops up, fill in the required key(s) and press **Authenticate**.

### (Re-)Authenticating an existing OneDrive for Business Account

Once the OneDrive for Business account is added, you can start using it. Only when you have a problem, you may need to re-authenticate it. Typical situations are that a token or password has expired or was revoked (error messages will mention this).

- In Configure > E-mail Accounts, select a OneDrive account and see its details on the right.
- Click Authenticate....
- In the Authenticate OneDrive Account dialog (specifically for OneDrive for Business), fill in the E-mail Address (automatically filled in), Tenant ID, Client ID and Client Secret.
- When clicking Sign In, a web browser opens and the user can sign in to his OneDrive for Business account. By doing so, Automation Engine can obtain a refresh token.



**Note:** The user has 3 minutes to sign in. After that period, the dialog will show an error.

- Configure Manually: It is also possible to manually fill in the refresh token. The steps are identical as described above.

### Create an app to enable access to files in OneDrive for Business

To enable interacting with OneDrive for Business, a dedicated app needs to be created (by your IT administrator) in your **Azure Active Directory admin center**.

1. The app needs to be configured with a **Redirect URI** for a **Web** platform that needs to be exactly like this (without the <> quotes):

[https://<FQDN\\_lowercase\\_hostname\\_on\\_which\\_AE\\_is\\_hosted>/ae/auth/app-redirecturi.idp](https://<FQDN_lowercase_hostname_on_which_AE_is_hosted>/ae/auth/app-redirecturi.idp)



**Note:** In an AE SaaS setup, Esko staff will provide the public name of the Automation Engine SaaS (master) server that is needed for the fully qualified domain name (FQDN) above.

2. A new **Client Secret** needs to be added as well.
3. And after that, the **Directory (tenant) ID**, the **Application (client) ID** and the **Client Secret's** value (not its ID!) should be captured and transferred to the corresponding fields mentioned above.
4. Finally, the app needs to be granted the necessary permissions (preferably with admin consent to avoid bothering every user at first sign-in to consent individually). These Microsoft Graph API delegated permissions are needed:
  - offline\_access
  - User.Read
  - IMAP.AccessAsUser.All

### Configuring Amazon S3

Follow these steps to create an account for Amazon S3:

1. In **Tools > Configure > Cloud Storage Services**, click **Add**, select **Amazon S3** and click **OK**.
2. The **Add Amazon S3 Account** dialog ask for keys which will allow Automation Engine the following actions on the **buckets** (root folders) that are linked to this account:
  - download, upload and remove files
  - create new folders.

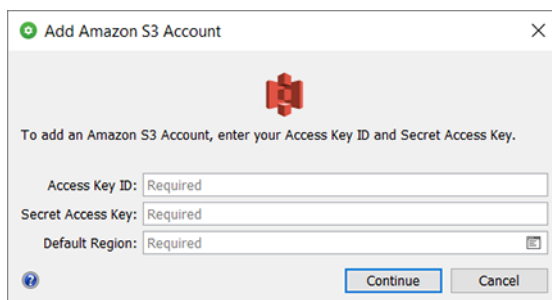

- Fill in the **Access Key ID** and **Secret Access Key** as generated in the IAM module for the user linked to this account. Contact your administrator for more details.
- **Default Region:** When all your buckets are in this same region anyway, specify it here so that you do not have enter it in the *upload task* settings.



**Note:** The IAM-defined user must have sufficient permissions to access the required **S3** buckets. Also consider limiting this user's access to one or more specific **S3** buckets. Learn more about IAM policies and access to S3 buckets in [this online article](#).



**Attention:** When your internet browser is already open, an account could already be logged in to that service. To make sure you log in with the right account, close your browser first.

3. Click **Continue** and add an **Account Name** and **Description**.
4. Click **Create** to confirm and close the dialog.



**Note:** You can reset the authorization for an account. This is needed when the authorisation token became invalid (it is broken, the administrator of the cloud storage deleted the site, ...). Follow these steps:

- Select the account for which you want to reset the authorization.
- Click **Authenticate**.
- In the dialog that pops up, fill in the required key(s) and press **Authenticate**.

### Create DCS Master

Short Name	Full Name
k	Black
y	Yellow
m	Magenta
c	Cyan

When you use the task *Create Master DCS File (Classic)*, you might want to map short names used in plates (that might not mean anything) to full ink names. This is handy for example for plates with international ink definitions. By default, C,M,Y and K are mapped to Cyan, Magenta, Yellow and Black.

To add an ink definition, double-click an input field and start typing. Press 'TAB' to switch fields.

### Digital Press

Use this to connect Automation Engine to the DFE (Digital Front End) of a digital press.

1. Select **Digital Press** and use **File > New** to create a new digital press connection.
2. Enter the name of your **DFE Server** and click **Connect**.



**Note:** Make sure the DFE server is running and reachable over the network.

If your connection is successful, you will see **Connection OK!** and details about the DFE server.

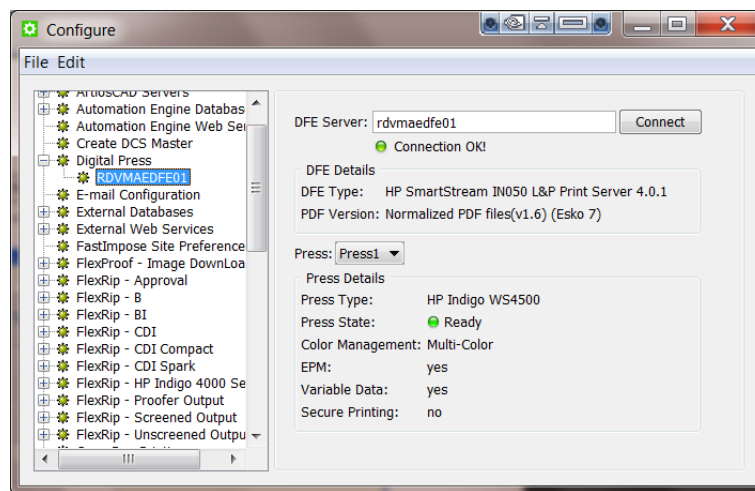

3. If your DFE server drives several presses, select the **Press** you want to connect to. You will see details about the digital press.
4. Use **File > Save** to save your connection.

### E-mail Accounts

#### Concept

These accounts use [OAuth 2.0](#), the industry-standard protocol for authorization.

They can be used in these cases:

- To have Automation Engine extract attachments from incoming e-mails through the [Gmail Access Point](#) and the [Exchange Access Point](#).
- To have Automation Engine send out e-mails, when so configured in the other Configuration topic [E-Mail Configuration](#) on page 194.

#### Adding an E-mail Account

To add an **E-mail Account**,

- Click **Add** or **+**.
- Select the **Provider** and click **OK**. See below pages for the next steps:

- [Gmail Account Configuration](#) on page 191.
- [Exchange Account Configuration](#) on page 192.

## Gmail Account Configuration

### Adding a new Gmail Account

Follow these steps to add a (Google) Gmail account:

1. In **Google Cloud Platform** (<https://console.cloud.google.com/>),
  - (check with your IT administrator to) create a project
  - and create an app to grant Automation Engine access to e-mail. Learn more below.
2. In **Automation Engine**, in the **Add Gmail Account** dialog, enter the **E-mail Address** for the account and copy the **Client ID** and **Client Secret** from the app registration. Learn more below.
  - When clicking **Sign In**, a web browser opens and the user can sign in to his Gmail account. By doing so, Automation Engine can obtain a token to be able to access Gmail account via OAuth2.



**Note:** The user has 3 minutes to sign in. After that period, the dialog will show an error.

- **Configure Manually:** It is also possible to manually fill in the refresh token. It is a more direct way to interact with the e-mail server that can offer a solution when you have problems to sign in.
  - Click **Configure Manually**.
  - The field **Refresh Token** appears and must be filled in.
  - When now clicking **Continue**, a check is done to see if the provided values can be used to access the Gmail account.



**Note:** When in manual mode, it is possible to go back to the "Sign In" mode by clicking on the "Back" button.

- When signing in was successful (either using the web browser or by giving the refresh token manually), a next dialog is shown asking you to complete the process by filling in an **Account Name** and a **Description**. Then click **Continue** and after that, choose with the **Use for access points** toggle whether or not to allow this account to be selected when setting up an Exchange access point.

### (Re-)Authenticating an existing Gmail Account

Once the Gmail account is added, you can start using it. Only when you have a problem, you may need to re-authenticate it. Typical situations are that a token or password has expired or was revoked (error messages will mention this).

- In **Configure > E-mail Accounts**, select a Gmail account and see its details on the right.
- Click **Authenticate....**
- In the **Authenticate Gmail Account** dialog, fill in the **E-mail Address** (automatically filled in), **Client ID** and **Client Secret**.
  - When clicking **Sign In**, a web browser opens and the user can sign in to his Gmail account. By doing so, Automation Engine can obtain a refresh token.



**Note:** The user has 3 minutes to sign in. After that period, the dialog will show an error.

- **Configure Manually:** It is also possible to manually fill in the refresh token. The steps are identical as described above.

### Create a project and an app to enable access to Gmail

To enable interacting with a mailbox in Gmail, it first has to be enabled for IMAP access after which a dedicated project and an app needs to be created (by your IT administrator) **in Google Cloud Platform**.

The app needs to be created with **OAuth client ID** credentials and be configured as a **Web application** with an **Authorized redirect URI** exactly like this (without the <> quotes):

[https://<FQDN\\_lowercase\\_hostname\\_on\\_which\\_AE\\_is\\_hosted>/ae/auth/app-redirecturi.idp](https://<FQDN_lowercase_hostname_on_which_AE_is_hosted>/ae/auth/app-redirecturi.idp)



**Note:** In an AE SaaS setup, Esko staff will provide the public name of the Automation Engine SaaS (master) server needed for the fully qualified domain name (FQDN) above.

After creation, the **Client ID** and **Client Secret** should be captured and transferred to the corresponding fields mentioned above.

## Exchange Account Configuration

### Adding a new Exchange Account

Follow these steps to add a (Microsoft 365) Exchange Online account:

1. **In Azure Active Directory admin center** (<https://aad.portal.azure.com/>),
  - (check with your IT administrator to) create an app to grant Automation Engine access to e-mail. Learn more below.
2. **In Automation Engine**, in the **Add Exchange Account** dialog, enter the **E-mail Address** for the account and copy the **Tenant ID**, **Client ID** and **Client Secret** from the app registration. Learn more below.
  - When clicking **Sign In**, a web browser opens and the user can sign in to their Exchange account. By doing so, Automation Engine can obtain a token to be able to access the Exchange account via OAuth2.



**Note:** The user has 3 minutes to sign in. After that period, the dialog will show an error.

- **Configure Manually:** It is also possible to manually fill in the refresh token. It is a more direct way to interact with the e-mail server that can offer a solution when you have problems to sign in.
  - Click **Configure Manually**.
  - The field **Refresh Token** appears and must be filled in.
  - When now clicking **Continue**, a check is done to see if the provided values can be used to access the Exchange account.



**Note:** When in manual mode, it is possible to go back to the "Sign In" mode by clicking on the "Back" button.

- When signing in was successful (either using the web browser or by giving the refresh token manually), a next dialog asks you to complete the process by filling in an **Account Name** and a **Description**. Then click **Continue** and after that, choose with the **Use for access points** toggle whether or not to allow this account to be selected when setting up an Exchange access point.
3. In **Microsoft 365 admin center** (<https://admin.microsoft.com/>), if this newly added Exchange account is to be used to configure outgoing mail as sent by Automation Engine (see [E-mail Configuration](#)), then (check with your IT administrator to) enable the corresponding Microsoft account to send mail via SMTP AUTH. Learn more below.

### (Re-)Authenticating an existing Exchange Account

Once the Exchange account is added, you can start using it. Only when you have a problem, you may need to re-authenticate it. Typical situations are that a token or password has expired or was revoked (error messages will mention this).

- In **Configure > E-mail Accounts**, select an Exchange account and see its details on the right.
- Click **Authenticate...**
- In the **Authenticate Exchange Account** dialog, fill in the **E-mail Address** (automatically filled in), **Tenant ID**, **Client ID** and **Client Secret**.
  - When clicking **Sign In**, a web browser opens and the user can sign in to his Exchange account. By doing so, Automation Engine can obtain a token to be able to access the Exchange account via OAuth2.



**Note:** The user has 3 minutes to sign in. After that period, the dialog will show an error.

- **Configure Manually:** It is also possible to manually fill in the refresh token. The steps are identical as described above.

### Create an app to enable access to e-mail on Exchange

To enable interacting with a mailbox in Exchange Online, a dedicated app needs to be created (by your IT administrator) in **Azure Active Directory admin center**.

1. The app needs to be configured with a **Redirect URI** for a **Web** platform that needs to be exactly like this (without the <> quotes):

[https://<FQDN\\_lowercase\\_hostname\\_on\\_which\\_AE\\_is\\_hosted>/ae/auth/app-redirecturi.idp](https://<FQDN_lowercase_hostname_on_which_AE_is_hosted>/ae/auth/app-redirecturi.idp)



**Note:** In an AE SaaS setup, Esko staff will provide the public name of the Automation Engine SaaS (master) server that is needed for the fully qualified domain name (FQDN) above.

2. A new **Client Secret** needs to be added as well.
3. And after that, the **Directory (tenant) ID**, the **Application (client) ID** and the **Client Secret**'s value (not its ID!) should be captured and transferred to the corresponding fields mentioned above.
4. Finally, the app needs to be granted the necessary permissions (preferably with admin consent to avoid bothering every user at first sign-in to consent individually). These Microsoft Graph API delegated permissions are needed:
  - offline\_access
  - User.Read
  - IMAP.AccessAsUser.All

### Enable a Microsoft account to send mail via SMTP AUTH

To allow Automation Engine to send mail from a mailbox in Exchange Online, authenticated client SMTP e-mail submission (in short "SMTP AUTH") must be enabled for the corresponding Microsoft account.

For that, in **Microsoft 365 admin center**, (your IT administrator has to) check for the active user owning the mailbox to have **Authenticated SMTP** enabled with the **Email apps** that are configured for this user.

### E-Mail Configuration

Automation Engine can use your e-mail server or account to send e-mails.

These e-mails can be sent by a task **Notification**, by a dedicated [Send E-mail task](#) or as an extra tool when you opened a log file.

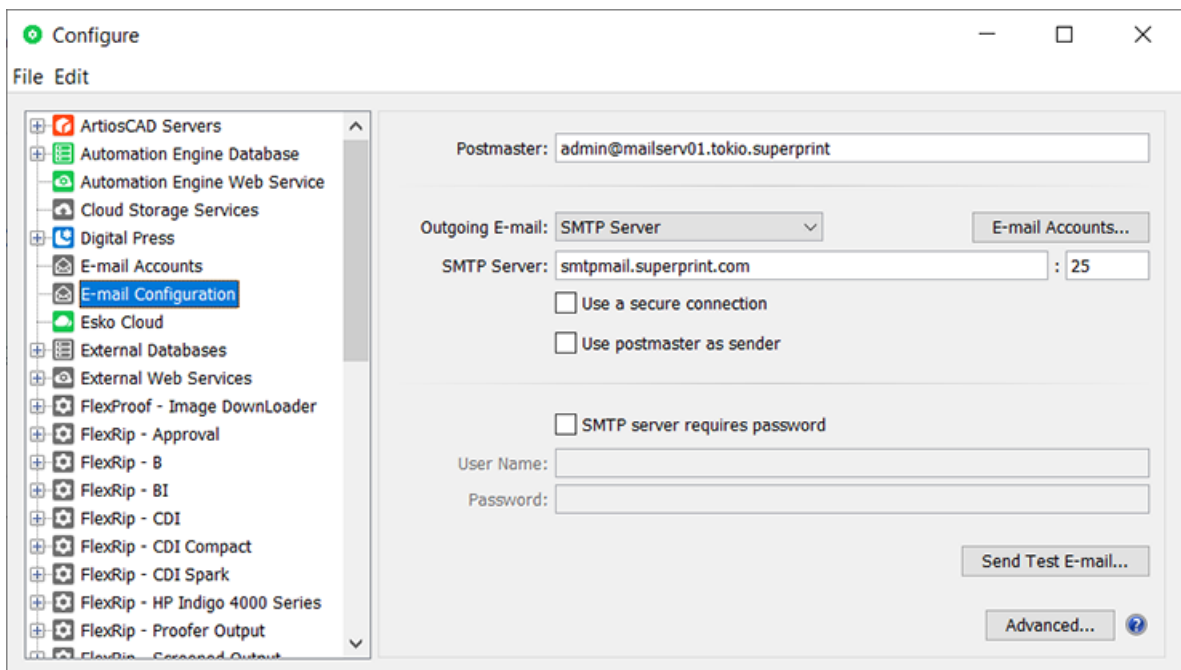

- **Postmaster:** This is the e-mail address that will receive a warning mail when an e-mail could not be delivered.
- **Outgoing E-mail:** Select either
  - a basic **SMTP Server** configuration and fill in its settings below
  - or select one of the **E-mail accounts** you created earlier in the other configuration topic [E-mail Accounts](#). These accounts use the more secure OAuth2 protocol.
- **SMTP Server:** Check with your IT department for the correct settings of the **SMTP Server** and its **Port**.
  - **Use a secure connection:** Select this option if you want to use a secure instead of an unrestricted connection.
  - **Use postmaster as sender:** Select this to include a "Sender" SMTP header.

The purpose of such a header is to indicate that the actual sender of the e-mail is different from the person in the '**From**' field of the e-mail. Some e-mail servers refuse to be instructed to send



e-mail without an appropriate sender being indicated.. Certain e-mail clients will visualise the **sender** info as "sent by <postmaster> on behalf of <from>".



**Note:** All *Red Alerts* are also sent as e-mail to this Postmaster.

- **SMTP server requires password** authentication: When this is the case, select this and fill out the **User Name** and **Password** fields.



**Note:** The following authentication schemes are supported by the Automation Engine mail component: **PLAIN, LOGIN** and **DIGEST-MD5**.

- **Advanced:** Use this to add generic properties for outgoing SMTP E-mail. Some examples:
  - To use office365 as SMTP server for outgoing e-mail, add the **Key** "mail.smtp.starttls.enable" with **Value** "true".
  - To get some debug information when there are problems with outgoing e-mails, add the **Key** "mail.debug" with **Value** "true".
- **Send Test E-mail...:** Click the button to send a test e-mail. An example:

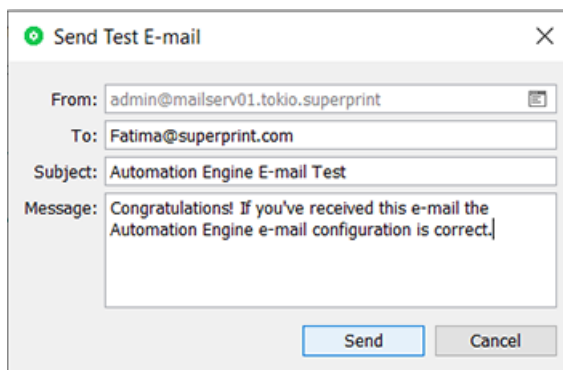

- **From:** (only available when for outgoing e-mail the basic type 'SMTP Server' is selected). Indicates the e-mail address you're using to send the test e-mail from. If no address is filled in, the postmaster address is used. You can choose a different sender to test if the mail server allows you to send e-mails on behalf of others. The **Send E-Mail** task relies on this behavior as it tries to send e-mails on behalf of the user that launches the task.
- **To:** Fill in a valid e-mail address that will receive the test mail.
- **Subject:** Fill in a subject line.
- **Message:** You can enter a personal message or leave the default text.
- When finished, click **Send** to see whether the configuration is working properly. When the e-mail could be sent, an Info message will appear. When it failed, you will get a detailed warning message.

## Esko Cloud

### Concept

Esko Cloud has a growing number of purposes:

- It is the backbone framework of the solution [Share & Approve](#).
- It can be used to collaborate between locations (Esko Cloud Connections) that have an Automation Engine server. Learn more in the chapter [Sharing to Collaborate with other AE servers](#) on page 1685.
- Automation Engine SaaS users can use Esko Cloud as a storage solution that is cheaper than keeping Jobs and Products in an AE Container (in a data center). Automation Engine SaaS users can also use Esko Cloud as the source place for their color data. Learn more in the chapter [AE SaaS: When your AE is in a Data Center](#) on page 1633.

## Settings

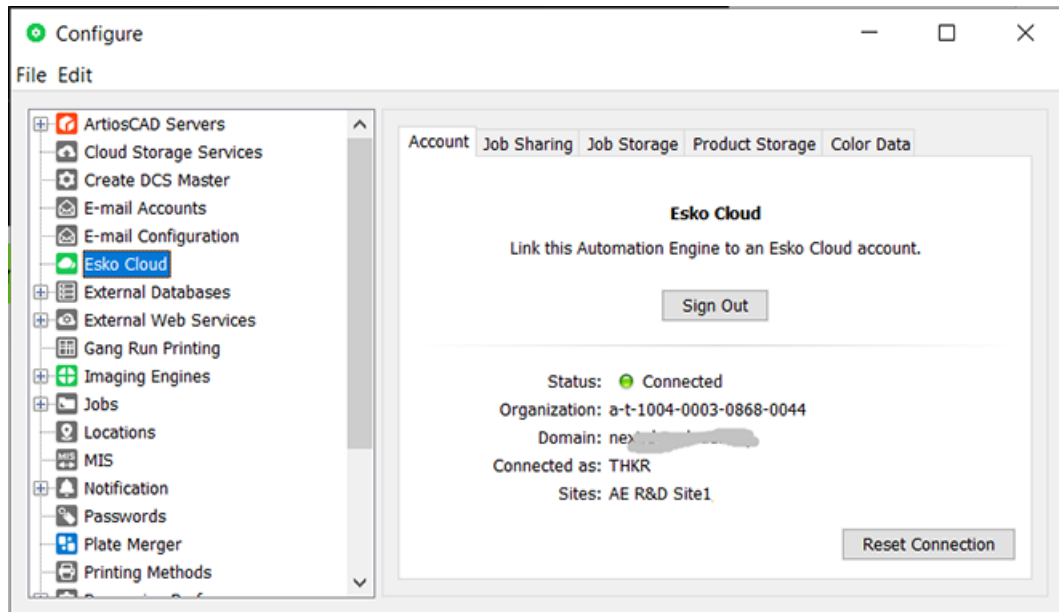

- **Account:** For all of the above cases you here **first** have to set up your Esko Cloud **Account**. Learn more about the initial configuration of Esko Cloud on [Initial Configuration](#) on page 1690 (setting up this Account is described in its [Step 3](#)).
- **MIS Prefix:** When using Esko Cloud, to avoid clashing resource IDs when working with multiple Automation Engine servers or multiple MIS, you need to define an MIS prefix. A warning icon is shown when no MIS prefix is defined. Click **Configure...** to define one. Learn more in [MIS](#) on page 221.
- **Job Sharing:**
  - **Create Job:** Select the ['Create Job' task](#) ticket that will be used when a shared job is downloaded for collaboration.
  - **When a shared job is created:** Select this to also automatically import the customer of that job.
  - **When a shared job is removed:** Select this to also delete the files and folders of that job.
- **Job Storage:** (AE SaaS only)
  - **Enable storage of inactive jobs:** Select this when you (also) want to use your Esko Cloud account to store jobs and their data. Learn more in [Storing Inactive Jobs on Esko Cloud](#) on page 1648.
  - **Site:** Select the Esko Cloud site you want to use for this purpose.

- **Product Storage:** (AE SaaS only)
  - **Enable storage of products:** Select this when you (also) want to use your Esko Cloud account to store products and their data.  
Learn more in [Storing Products on Esko Cloud](#) on page 1658.
  - **Site:** Select the Esko Cloud site you want to use for this purpose.
- **Color Data:** (AE SaaS only)  
This tool enables your AE SaaS server to use the color data from Esko Cloud.  
Important in this concept:
  - There many types of color data that are **not yet supported** to be used from Esko Cloud.
  - Enabling this tool will **delete your color data on Automation Engine**.
 Learn more on the concept, the required preparation and detailed configuration in the chapter about AE SaaS, on the page [Using Esko Cloud for Color Data](#) on page 1666.

## External Databases

**External Databases** are databases from external systems (not part of Automation Engine).

Automation Engine uses links to such databases in

- a **Database Query SmartName**. Learn more [here](#).
- a **Database Access Point**. Learn more [here](#).
- the **Interact with Database** task. Learn more [here](#).



**Attention:** When integrating Automation Engine with an external database, make sure you are compliant with the license agreements of that database manufacturer.



**Note:** Configuring these links requires knowledge about database setups. If necessary, contact your IT database administrator to figure out the correct settings.

## Configuring External Databases

1. Go to **Tools > Configure > External Databases**.
2. Click **File > New** to configure a new link to a database.  
A new database name is created with the name **db\_number** (the number is the chronological number of the database).
3. In the left pane, click to select the new database and then click again to enable renaming that new database link. Type the name you want and press **Enter** to confirm.
4. Choose the appropriate **DBMS Type**.  
These Database Management Systems (DBMS) are supported:
  - **Microsoft SQL Server**
  - **Oracle**
  - **Other** (using a JDBC driver).



**Attention:** Esko provides the drivers for both SQL and Oracle DBMS types. Not all database drivers can be freely distributed by Esko, and not all drivers have been tested. If you need to connect to **Other** types, you need to connect using a JDBC driver.

- **ODBC Source (Soon Outdated).** This is an outdated technology and was set to 'soon outdated' in AE 22.07. Please use of the others mentioned above. Learn more about (soon) outdated features [here](#).
- 5. Enter the connection details. These are different per type of DBMS. See examples in [Specifics per DBMS](#) on page 198.
- 6. On an [AE SaaS](#), specify the local [Agent](#) that will interact with the external database in that same location.
- 7. If required for the DBMS, enter the name of the **Host**. This is the database server (computer) name.
- 8. If required for the DBMS, enter the **Port** number.
- 9. If required for the DBMS, enter the **User** name and **Password** that will be used to access the database.
- 10. Click '**Test Connection**' to test if your setup is valid. If it is not valid, the error message might contain details about the problem.
- 11. **Disclaimer:** Be aware of the risks of direct database queries and of the fact that Esko takes no liability for them. You need to agree before this configuration can be saved.
- 12. Click **File > Save** to save the configuration.

See the next section for some [specifics per DBMS](#).

## Specifics per DBMS

### Connecting to a Microsoft SQL Server

The screenshot shows a configuration form for a Microsoft SQL Server connection. The fields are as follows:

- DBMS Type:** Microsoft SQL Server (dropdown menu)
- Database:** MyExternalSystem
- Host:** eaw11dl306
- Port:** (empty field)
- User:** admin
- Password:** (masked with six dots)

A **Test Connection** button is located at the bottom right of the form.

When choosing this DBMS type, the supported databases will be restricted to the supported versions of SQL Server that is used for the Automation Engine databases. Please check the [system requirements](#) page to see which SQL Server versions are supported.

When the External Microsoft SQL Server version is running a different version, please check Esko Knowledge Base article [KB205229874](#) for possible workarounds.

### Connecting to an Oracle Server

### Connecting an "Other" DBMS

**Other** DBMS can be accessed if you can get the necessary drivers and information on how to access the DBMS via standard JDBC technology.

- Download the JDBC driver (a jar file) from the manufacturer’s website into a **Container** that is accessible to the Automation Engine (Master) server.
- Enter the required configuration fields. See an example:

- Check your JDBC driver manual for more details.

### Connecting to an ODBC Source (Soon Outdated)



**Warning:** From AE 22.07 on, (32-bit) ODBC query SmartNames are set to be **'Soon Outdated'**. This includes setting up such a configuration. Learn more in [Concept of \(Soon\) Outdated Tasks / Features](#) on page 531.

### External Web Services

Using the task [Interact with Web Service](#), Automation Engine can communicate with web services from external systems.

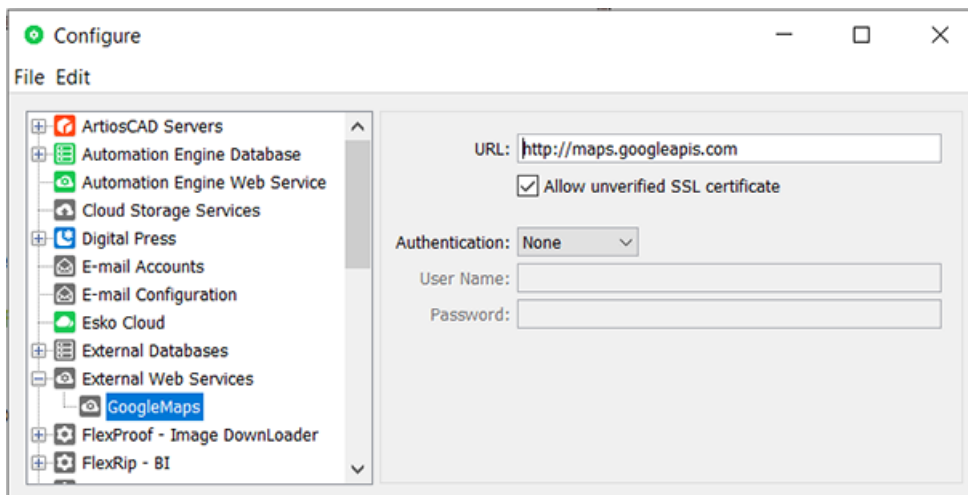

To configure such a web service,

1. Go to **Tools > Configure > External Web Services**.
2. Press the **Insert** key or go to **File > New**. Specify a name for the new external web service.
3. Specify the **URL**.
4. **Allow unverified SSL Certificate**

In case a "secure" HTTPS service is being addressed, but the server is using an "insecure" SSL certificate (typically so called "self-signed certificate"), you can indicate that the security problem may be ignored by checking the "Allow unverified SSL Certificate".

If you need to pass via a proxy, configure the proxy settings via **Tools > Configure > Web Proxy**.

- **On an AE SaaS server:** In a SaaS environment, these extra options appear:

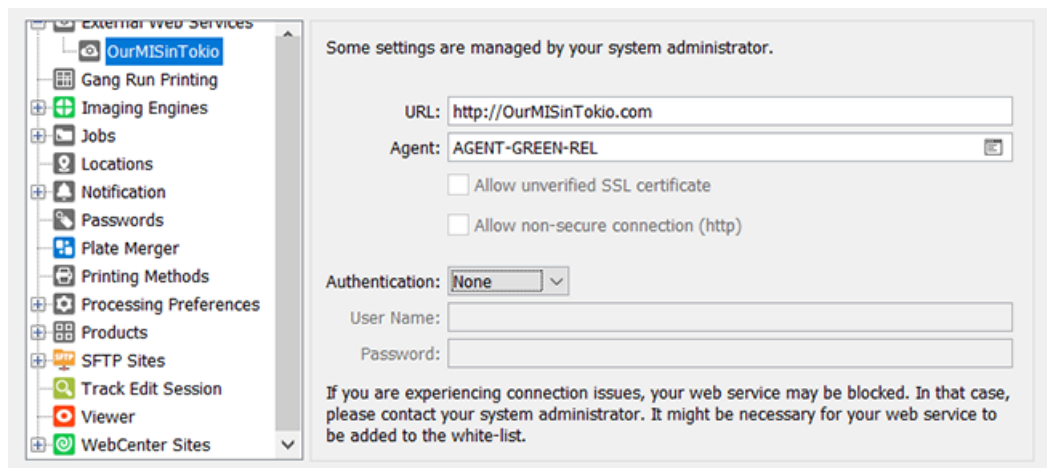

- **Agent:** In an AE SaaS setup, the communication to that URL needs to happen via an [Agent](#). From the list, select the Agent that is in the same local network as the system or device you want the AE server to communicate with.
- **Allow non-secure connection (http):** On an AE SaaS server, unverified SSL certificates are not allowed, unless explicitly allowed by Esko Platform Operations staff.

5. Select the **Authentication** mode that the external web service requires:

- **None:** When the web service doesn't require any authentication.
- **Basic:** When a **User Name** and **Password** is required.
- **WebCenter:**



**Important:** This option was relevant before the dedicated task [Integrate with WebCenter](#) was available.

This option allows this **Interact with Web Service** task to connect to an old version of WebCenter before v14. This old method also implies that you need to configure the WebCenter server in this ticket and understand the 'Rest API' of WebCenter.

6. Click **File > Save**.



**Important:** If you are experiencing connection problems, your web service may be blocked. In that case please contact your system administrator. It might be necessary for your web service to be added to the whitelist.

## FastImpose Site Preferences

The FastImpose site preferences serve to map ink names to custom names. For example if you want to map 'C' to the French 'bleu' on your plates.

### Ink Names

Click **Add** to add two initial values to the list: **key** and **value**. Double click the words to edit them.



**Tip:** A black rectangle around the field indicates that you can edit it.

If you want to change 'C' to 'Bleu', then enter C in the **Name** column, and 'Bleu' in the **Customized Name** column:

Ink Names		Surfaces
Name	Customized Name	
C	Bleu	

Add Remove

This does not change your file, but if you used marks that would output 'C' on plate, they will now mention that ink as 'Bleu'.

### Surfaces

When the values that describe front - back printing modes, like F/B, Front/Back, Back, F, Front, B are not conform your language or your way of working, you can here change them.

An example: changing Front/Back to read Recto/Verso:

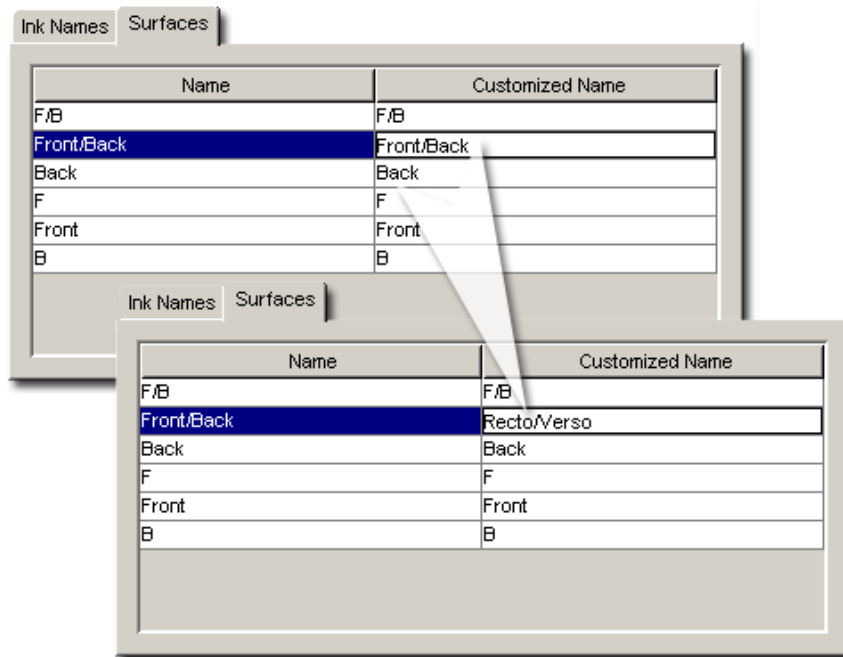

### FlexProof - Image Downloader

Select the item **FlexProof - Image Downloader** and go to **File > New**.



**Note:** Don't forget to save your settings. Use **File > Save**.

#### Tab "General"

- **Type:** The type will appear after having synchronized. First fill in the other settings.
- **Proofer Node:** Enter the FlexProof computer name.



**Attention:** The name of the Image Downloader Proof Node is case sensitive. This is not the case for the other devices.

- **Synchronize with Proof Node.** This may take a few seconds, the system will fill out the **'Type'** field.

#### Tab "Queue"

- **Queue:** A default name is proposed. This field automatically updates when you rename the device.
- **Queue Job Limit:** A FlexRip's Dispatcher EskoLink queue can handle the expose command of 2 jobs at the same time. If you want the Automation Engine queue to allow sending 2 expose commands at the same time, then set the job limit of the Automation Engine queue on 2.



Putting this job limit on 1 will result in each expose command to that EskoLink queue being handled one by one: the second job will be ripped after the first one is completely finished ("First In First Out" principle).



**Note:** Having jobs RIP'ed earlier on the FlexRip does not mean that your output device can output them any earlier.

### Tab "Merge"

- **Merge:** Define if you want merge jobs on output.
- **Unit.** Select a unit for the below fields.
- **Margin:** Define an extra margin around the output.
- **Gap:** When merging, a gap adds an extra zone of empty pixels around each job.
- **Minimum Fill:** When merging, enter what percentage of minimum fill you want in the output. No output is generated before this fill percentage is reached.

### FlexRip - Approval

Select the item **FlexProof - Approval** and go to **File > New**.



**Note:** Don't forget to save your settings. Use **File > Save**.

### Tab "General"

- **Type:** The type will appear after having synchronized. First fill in the other settings.
- **Rip Node:** Enter the FlexRip/FlexProof computer name.
- **EskoLink Portnr.:** Enter the port number of the Dispatcher's EskoLink queue.
- Fill out these fields before you click **Synchronize with Rip**. This may take a few seconds.

### Tab "Queue"

- **Queue:** A default name is proposed. This field automatically updates when you rename the device.
- **Queue Job Limit:** A FlexRip's Dispatcher EskoLink queue can handle the expose command of 2 jobs at the same time. If you want the Automation Engine queue to allow sending 2 expose commands at the same time, then set the job limit of the Automation Engine queue on 2.  
  
Putting this job limit on 1 will result in each expose command to that EskoLink queue being handled one by one: the second job will be ripped after the first one is completely finished ("First In First Out" principle).



**Note:** Having jobs RIP'ed earlier on the FlexRip does not mean that your output device can output them any earlier.

**Tab "Merge"**

- **Merge:** Define if you want merge jobs on output.
- **Unit.** Select a unit for the below fields.
- **Margin:** Define an extra margin around the output.
- **Gap:** When merging, a gap adds an extra zone of empty pixels around each job.
- **Minimum Fill:** When merging, enter what percentage of minimum fill you want in the output. No output is generated before this fill percentage is reached.

**FlexRip - B**

Select the item **FlexRip - B** and go to **File > New**.



**Note:** Don't forget to save your settings. Use **File > Save**.

**Tab "General"**

- **Type:** The type will appear after having synchronized. First fill in the other settings.
- **Rip Node:** Enter the FlexRip computer name.
- **EskoLink Portnr.:** Enter the port number of the Dispatcher's EskoLink queue.
- Fill out these fields before you click **Synchronize with Rip**. This may take a few seconds.

**Tab "Queue"**

- **Queue:** A default name is proposed. This field automatically updates when you rename the device.
- **Queue Job Limit:** A FlexRip's Dispatcher EskoLink queue can handle the expose command of 2 jobs at the same time. If you want the Automation Engine Queue to allow sending 2 expose commands at the same time, then set the job limit of the Automation Engine queue on 2.  
  
Putting this job limit on 1 will result in each expose command to that EskoLink queue being handled one by one: the second job will be ripped after the first one is completely finished ("First In First Out" principle).



**Note:** Having jobs RIP'ed faster on the FlexRip does not mean that your output device can output them any earlier.

- **Optimize Expose Sequence:** Select this to have all separations RIP'ed in one pass, which normally leads to faster output. For some jobs however, this way of working results in memory problems,

when this happens, deselect this option so that all separations will be RIP'ed separately (the RIP will be restarted after every separation).

**Tab "Merge"**

- **Merge:** We advise to set this to **No** as merging will then happen after this pass on the way to the Imagesetter and this gives a higher flexibility in merging (positive and negative can be merged on one film).
- **Unit.** Select a unit for the below fields.
- **Margin:** Define an extra margin around the separations.
- **Gap:** When merging, a gap adds an extra zone of empty pixels around each separation.
- **Minimum Fill:** When merging, enter what percentage of minimum fill you want in the output. No output is generated before this fill percentage is reached.

**FlexRip - BI (Barco Imagesetter)**

Select the item **FlexRip - BI (Barco Imagesetter)** and go to **File > New**.



**Note:** Don't forget to save your settings. Use **File > Save**.

**Tab "General"**

- **Type:** The type will appear after having synchronized. First fill in the other settings.
- **Rip Node:** Enter the FlexRip computer name.
- **EskoLink Portnr.:** Enter the port number of the Dispatcher's EskoLink queue.
- Fill out these fields before you click **Synchronize with Rip**. This may take a few seconds.

**Tab "Queue"**

- **Queue:** A default name is proposed. This field automatically updates when you rename the device.
- **Queue Job Limit:** A FlexRip's Dispatcher EskoLink queue can handle the expose command of 2 jobs at the same time. If you want the Automation Engine Queue to allow sending 2 expose commands at the same time, then set the job limit of the Automation Engine queue on 2.  
Putting this job limit on 1 will result in each expose command to that EskoLink queue being handled one by one: the second job will be ripped after the first one is completely finished ("First In First Out" principle).



**Note:** Having jobs RIP'ed faster on the FlexRip does not mean that your output device can output them any earlier.

- **Optimize Expose Sequence:** Select this to have all separations RIP'ed in one pass, which normally leads to faster output. For some jobs however, this way of working results in memory problems, when this happens, deselect this option so that all separations will be RIP'ed separately (the RIP will be restarted after every separation).

**Tab "Merge"**

- **Merge:** because this device type cannot merge, this settings is always on '**No**'
- Select a **Unit** for the below field.
- **Margin:** Define an extra margin around the separations.

**FlexRip CDI, CDI Spark and CDI Compact**

These three types of devices can be configured in the same way. Select the matching item and go to **File > New**.



**Note:** Don't forget to save your settings. Use **File > Save**.

**Tab "General"**

- **Type:** The type will appear after having synchronized. First fill in the other settings.
- **Rip Node:** Enter the FlexRip computer name.
- **EskoLink Portnr.:** Enter the port number of the Dispatcher's EskoLink queue.
- Fill out these fields before you click **Synchronize with Rip**. This may take a few seconds.

**Tab "Queue"**

- **Queue:** A default name is proposed. This field automatically updates when you rename the device.
- **Queue Job Limit:** A FlexRip's Dispatcher EskoLink queue can handle the expose command of 2 jobs at the same time. If you want the Automation Engine Queue to allow sending 2 expose commands at the same time, then set the job limit of the Automation Engine queue on 2.

Putting this job limit on 1 will result in each expose command to that EskoLink queue being handled one by one: the second job will be ripped after the first one is completely finished ("First In First Out" principle).



**Note:** Having jobs RIP'ed faster on the FlexRip does not mean that your output device can output them any earlier.

- **Optimize Expose Sequence:** Select this to have all separations RIP'ed in one pass, which normally leads to faster output. For some jobs however, this way of working results in memory problems, when this happens, deselect this option so that all separations will be RIP'ed separately (the RIP will be restarted after every separation).

**Tab "Merge"**

- **Merge:** Define if you want merge jobs on output.
- **Unit.** Select a unit for the below fields.
- **Margin:** Define an extra margin around the output.
- **Gap:** When merging, a gap adds an extra zone of empty pixels around each job.
- **Minimum Fill:** When merging, enter what percentage of minimum fill you want in the output. No output is generated before this fill percentage is reached.

**Tab "CDI"**

When the CDI has a recent version of Grapholas software, the **Pixelclock** will here be shown as **'Automatic'**.

Older versions ask you to define the values here:

- **Pixelclock** is set to 360.000.
- **Perimeter:** Define the perimeter of the drum, in the selected unit.

**FlexRip - HP Indigo 4000 Series**

Select the item **FlexRip - HP Indigo 4000 Series** and go to **File > New**.



**Note:** Don't forget to save your settings. Use **File > Save**.

**Tab "General"**

- **Type:** The type will appear after having synchronized. First fill in the other settings.
- **Rip Node:** Enter the FlexRip computer name.
- **EskoLink Portnr.:** Enter the port number of the Dispatcher's EskoLink queue.
- Fill out these fields before you click **Synchronize with Rip**. This may take a few seconds.

**Tab "Queue"**

- **Queue:** A default name is proposed. This field automatically updates when you rename the device.
- **Queue Job Limit:** A FlexRip's Dispatcher EskoLink queue can handle the expose command of 2 jobs at the same time. If you want the Automation Engine Queue to allow sending 2 expose commands at the same time, then set the job limit of the Automation Engine queue on 2.  
  
Putting this job limit on 1 will result in each expose command to that EskoLink queue being handled one by one: the second job will be ripped after the first one is completely finished ("First In First Out" principle).



**Note:** Having jobs RIP'ed faster on the FlexRip does not mean that your output device can output them any earlier.

- **Optimize Expose Sequence:** Select this to have all separations RIP'ed in one pass, which normally leads to faster output. For some jobs however, this way of working results in memory problems, when this happens, deselect this option so that all separations will be RIP'ed separately (the RIP will be restarted after every separation).

### FlexRip - Proofer Output

Select the item **FlexRip - Proofer Output** and go to **File > New**.



**Note:** Don't forget to save your settings. Use **File > Save**.

#### Tab "General"

- **Type:** The type will appear after having synchronized. First fill in the other settings.
- **Rip Node:** Enter the FlexRip computer name.
- **EskoLink Portnr.:** Enter the port number of the Dispatcher's EskoLink queue.
- Fill out these fields before you click **Synchronize with Rip**. This may take a few seconds.

#### Tab "Queue"

- **Queue:** A default name is proposed. This field automatically updates when you rename the device.
- **Queue Job Limit:** A FlexRip's Dispatcher EskoLink queue can handle the expose command of 2 jobs at the same time. If you want the Automation Engine Queue to allow sending 2 expose commands at the same time, then set the job limit of the Automation Engine queue on 2.  
Putting this job limit on 1 will result in each expose command to that EskoLink queue being handled one by one: the second job will be ripped after the first one is completely finished ("First In First Out" principle).



**Note:** Having jobs RIP'ed faster on the FlexRip does not mean that your output device can output them any earlier.

#### Tab "Proof"

##### Recombine Separations:

You can define this workflow choice: or you choose to let the FlexRip recombine the separations or you choose to add a 'Proof (FlexProof)' task.

- **On the FlexRip,** you can add a margin, no merging is possible.
- **By Sequencing A 'Proof (Image Downloader)' Task:** You then need to select the ['FlexProof - Image Downloader'](#) device from the list.



**Note:** The list only shows those devices that are configured for the same node ; the RIP and Proof node must be identical.

## FlexRip - Screened Output

### Shared Settings for all FlexRip flavors of Screened and Unscreened Output

- **Tab "General"**
  - **Type:** The type will appear after having synchronized. First fill in the other settings.
  - **Rip Node:** Enter the FlexRip computer name.
  - **EskoLink Portnr.:** Enter the port number of the Dispatcher's EskoLink queue.
  - Fill out these fields before you click **Synchronize with Rip**. This may take a few seconds.
- **Tab "Queue"**
  - **Queue:** A default name is proposed. This field automatically updates when you rename the device.
  - **Queue Job Limit:** A FlexRip's Dispatcher EskoLink queue can handle the expose command of 2 jobs at the same time. If you want the Automation Engine Queue to allow sending 2 expose commands at the same time, then set the job limit of the Automation Engine queue on 2.  
 Putting this job limit on 1 will result in each expose command to that EskoLink queue being handled one by one: the second job will be ripped after the first one is completely finished ("First In First Out" principle).



**Note:** Having jobs RIP'ed faster on the FlexRip does not mean that your output device can output them any earlier.

- **Tab "Merge"**
  - **Merge:** Define if you want merge jobs on output.
  - **Unit.** Select a unit for the below fields.
  - **Margin:** Define an extra margin around the output.
  - **Gap:** When merging, a gap adds an extra zone of empty pixels around each job.
  - **Minimum Fill:** When merging, enter what percentage of minimum fill you want in the output. No output is generated before this fill percentage is reached.

## DCS

Select the item **DCS** below the item **FlexRip - Screened Output** and go to **File > New**.



**Note:** Don't forget to save your settings. Use **File > Save**.

All options in the menu tabs are equal to those for other flavors. They are described in the page [FlexRip - Screened Output](#) on page 209.

**TIFF**

Select the item **TIFF** below the item **FlexRip - Screened Output** and go to **File > New**.



**Note:** Don't forget to save your settings. Use **File > Save**.

All options in the menu tabs are equal to those for other flavors. They are described in the page [FlexRip - Screened Output](#) on page 209.

There is one exception for the TIFF flavor: The tab "Queue" offers this extra option:

- **Optimize Expose Sequence:** Select this to have all separations RIP'ed in one pass, which normally leads to faster output. For some jobs however, this way of working results in memory problems, when this happens, deselect this option so that all separations will be RIP'ed separately (the RIP will be restarted after every separation).

**PDF**

Select the item **PDF** below the item **FlexRip - Screened Output** and go to **File > New**.



**Note:** Don't forget to save your settings. Use **File > Save**.

All options in the menu tabs are equal to those for other flavors. They are described in the page [FlexRip - Screened Output](#) on page 209.

**PS**

Select the item **PS** below the item **FlexRip - Screened Output** and go to **File > New**.



**Note:** Don't forget to save your settings. Use **File > Save**.

All options in the menu tabs are equal to those for other flavors. They are described in the page [FlexRip - Screened Output](#) on page 209.

**FlexRip - Unscreened Output**

**DCS**

Select the item **DCS** below the item **FlexRip - Unscreened Output** and go to **File > New**.



**Note:** Don't forget to save your settings. Use **File > Save**.

All options in the menu tabs are equal to those for other flavors. They are described in the page [FlexRip - Screened Output](#) on page 209.



## TIFF

Select the item **TIFF** below the item **FlexRip - Unscreened Output** and go to **File > New**.



**Note:** Don't forget to save your settings. Use **File > Save**.

All options in the menu tabs are equal to those for other flavors. They are described in the page [FlexRip - Screened Output](#) on page 209.

There is one exception for the TIFF flavor: The tab "Queue" offers this extra option:

- **Optimize Expose Sequence:** Select this to have all separations RIP'ed in one pass, which normally leads to faster output. For some jobs however, this way of working results in memory problems, when this happens, deselect this option so that all separations will be RIP'ed separately (the RIP will be restarted after every separation).

## PDF

Select the item **PDF** below the item **FlexRip - Unscreened Output** and go to **File > New**.



**Note:** Don't forget to save your settings. Use **File > Save**.

All options in the menu tabs are equal to those for other flavors. They are described in the page [FlexRip - Screened Output](#) on page 209.

## PS

Select the item **PS** below the item **FlexRip - Unscreened Output** and go to **File > New**.



**Note:** Don't forget to save your settings. Use **File > Save**.

All options in the menu tabs are equal to those for other flavors. They are described in the page [FlexRip - Screened Output](#) on page 209.

## Gang Run Printing

These fields are relevant when you work with the Pilot's **Gang Run Printing** view.

- **Output Folder:** Define the folder where the substrate queues write their nested layout files. These files are picked up from here as input files for the output workflow (specifically the [Export Gang Run Layouts task](#)). Normal use of the Gang Run Printing mode does not require you to access these files.



**Note:** We advise to clean up these temp data. This can easily done in your output workflow ticket: See this example:



- The **Custom Fields** can be given specific names so that they can be used in the *'Extra' tab of the Submit to Gang Run task*. They then show up as extra columns in the Gang Run printing view of a specific Substrate Queue.
- If you also confirm that a **Custom Field** can be **Used as grouping key**, the value of this field will so help control which files are nested together. Typical attributes to base nesting groups on are Customer, Printing Method, Finishing Method. Learn more about grouping keys in *Grouping Certain Graphics Together* on page 982.
- Select **Use the Customer field as grouping key** if you want a system-wide setting for this feature, instead of having to control it per ticket of the *Submit to Gang Run task*.

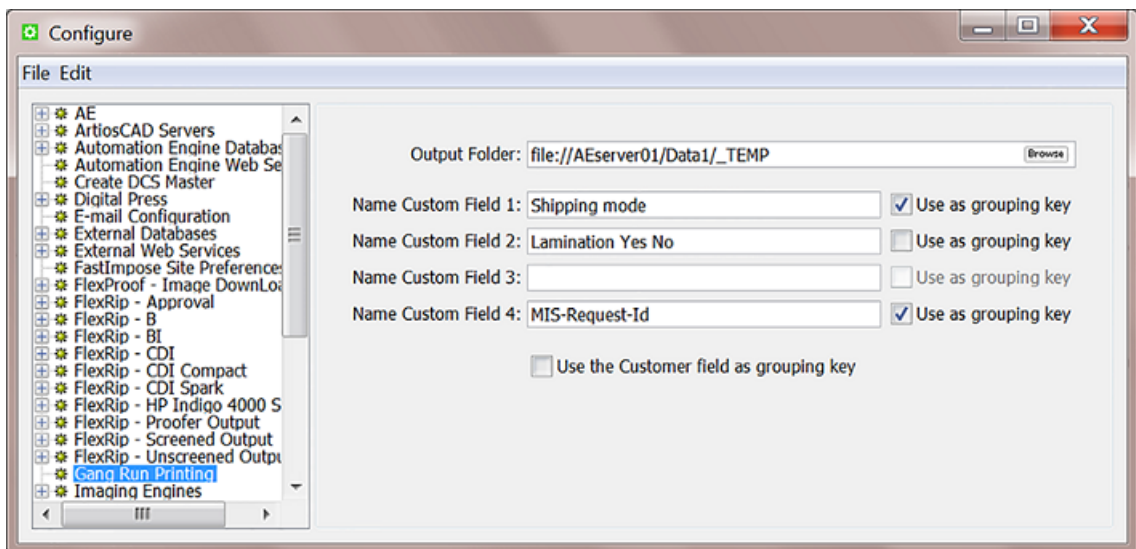

## GlobalVision

### Concept

Following Automation Engine tasks use technology from the company *GlobalVision: Inspect Artwork, Inspect Barcodes, Inspect Braille, Inspect Spelling and Inspect Text*.

These tasks require a software license created by GlobalVision. You can purchase various subscription packages directly from GlobalVision or choose to purchase one via Esko.

### Enter and Test your GlobalVision License Key

In this field, enter the license key you received from GlobalVision, followed by a colon ( : ), and your Company ID (as customer of GlobalVision).

Don't forget to save (**File > Save**).



**Important:** The license key is not validated here in the Configure tool. You will only see that the license key is invalid or expired when you run one of the GlobalVision inspection tasks. This also implies that you need an internet connection to run these tasks.

### Imaging Engines

This is where you configure any Imaging Engine RIPs.

Learn more in the chapter [RIP'ing with Imaging Engine](#), in the page [Imaging Engine Configuration](#) on page 1253.

### Jobs



**Tip:** Working with Automation Engine Jobs is documented in the dedicated chapter [Jobs](#) on page 538.

### Job Setup

You can here define the name of several **Custom Fields**.

When you enter names in custom fields 3 to 6, an extra tab **Categorization** will appear in the **Job Setup** dialog box.



**Note:** Think carefully about these names because changing their names later creates confusing lists of values for these fields in existing Jobs.

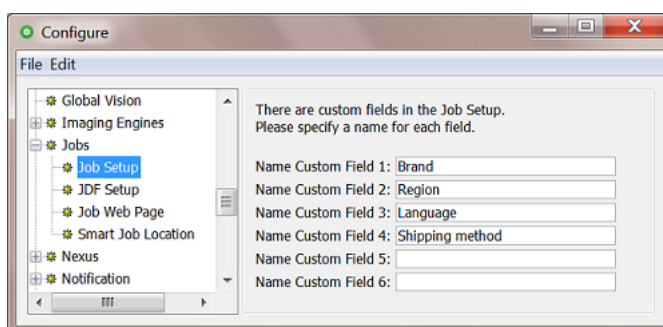

### JDF Setup

This item allows to define default settings that are used when (new) Jobs are created via JDF/JMF.

- Tab "**Settings for JDF job creation**"
  - **Job Name** and **Job Folder:** Use SmartNames to define the name and folder of the resulting Job.

- **Apply Job Setup:** This option allows to create a same job folder structure for each new Job created via JDF. Select the option and click **Select** the Job of which you want to take over its job folder structure.

You can also indicate what other items should be copied from that Job, apart from the **Folders**. Select **Tickets** to also copy any (blue) Job tickets into the new Job. Select **Parameters** to also copy those defined in the Job's setup tab 'Parameters'.

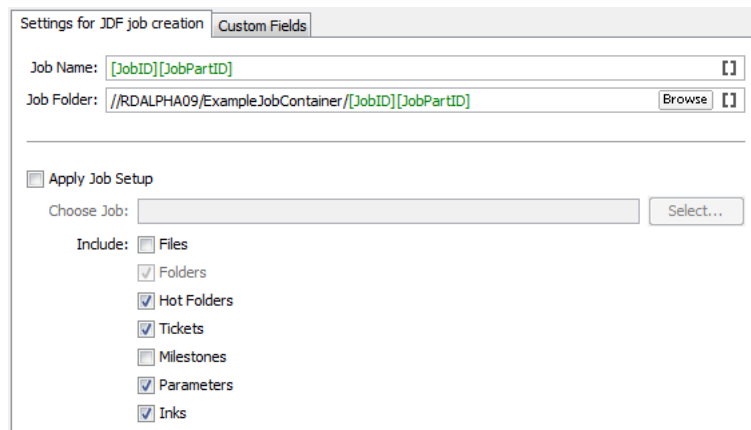

- Tab "**Custom Fields**"

This is where you can define how the data in the "Comment" JDF elements is used to populate the custom fields (**Categories**) that appear in the Job Setup dialog.

To do this, type an XPath expression into the field corresponding to the category you want to fill in automatically. To get some help, click **Edit** to open the [XPath builder](#).



**Note:**

- The JDF that was loaded in the XPath builder is remembered while the **Configure** dialog is open.
- When editing the next XPath, the same JDF will be automatically used as the example XML in the XPath builder.

Settings for JDF job creation
Custom Fields

During job creation from JDF, the 2 job custom fields are set to values found under the Comment elements with names equal to Description2 and Description3 respectively. This can be overruled by specifying an XPath expression.

XPath Custom Field 1:  Edit

XPath Custom Field 2:  Edit

To map values from the JDF file onto the extra Custom Fields during job creation from JDF, specify an XPath expression for each Custom Field that should be filled.

XPath Custom Field 3:  Edit

XPath Custom Field 4:  Edit

XPath Custom Field 5:  Edit

XPath Custom Field 6:  Edit

### XPath Builder

#### Concept

When you click **Edit** in any field that allows XPath Expressions, the **XPath Builder** opens.

The XPath Builder offers alternative starting points:

- The XPath is not resolved relative to the root node of the XML document, but from another XML element.
- When a proper JDF is used as the example XML, a list of possible starting points is generated.
- While the XPath builder automatically selects the appropriate starting point, it is still possible to manually change the starting point by clicking on another node while holding down **Command** (Mac) or **CTRL** (Windows).

#### Example

See an example where the XPath builder is used to create an XPath for a product part attribute:

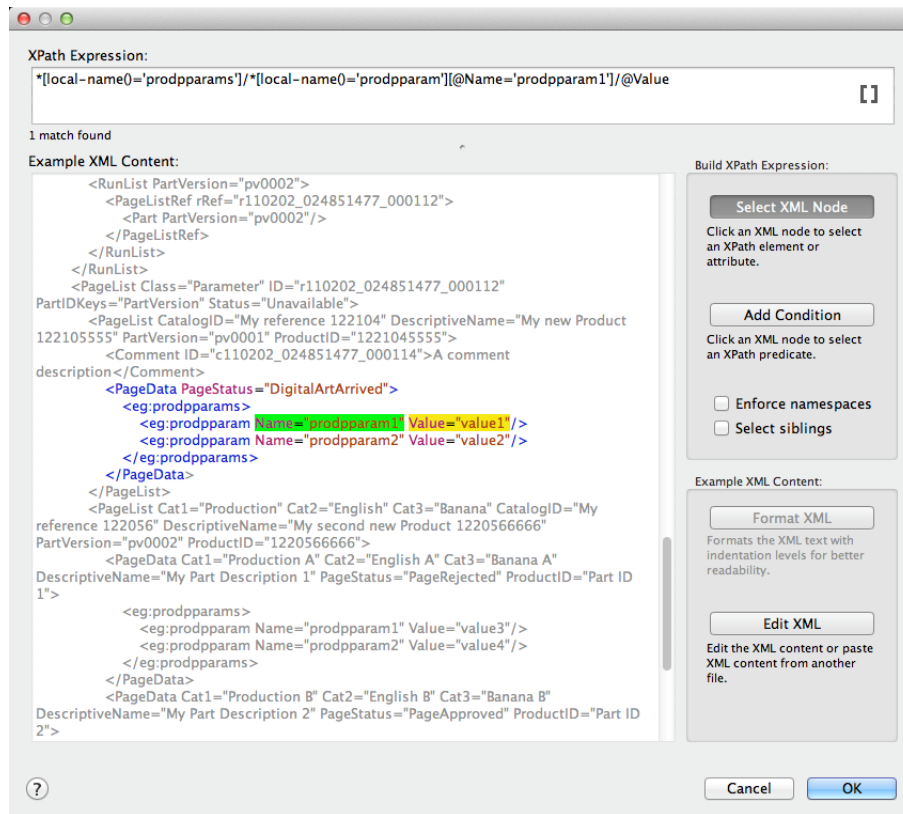

- The XPath builder automatically uses the first PageData node as starting point. This is visualised by showing the content outside the PageData node in grey.
- It is still possible to select nodes outside the PageData node as result node or as predicate node.
- When selecting nodes outside the PageData node, the XPath builder will create absolute XPaths.
- When you want, you can modify these absolute paths by making them relative to the PageData node using ../

## Job Web Page

### Concept

In the Pilot, you can right-click a job folder and select **Go to Job Web Page**. This opens an internet browser and loads a predefined path (URL).

This is typically used to navigate from within an Automation Engine Job to its related WebCenter project.

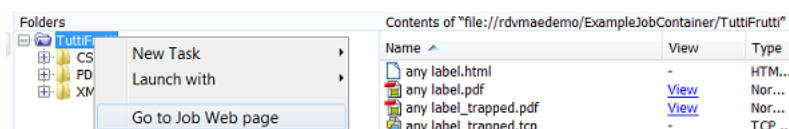

### Configuration

This is where you define the web **Address** for the **Job Web Page**. Obviously, it needs to be a valid URL, so if you use SmartNames, make sure they resolve correctly.

This is the typical structure of such a URL to a WebCenter project:

- The first part of the URL is typically the name of your WebCenter web site. For example `http://MyWebCenterServer/WebCenter_Inst`
- This is followed by `/projdetails.jsp?projectName=`
- You end with a SmartName that resolves as the name of the WebCenter project for that job. For example: when the WebCenter project has the same name as the Job on Automation Engine, then use `[Job Name]`.

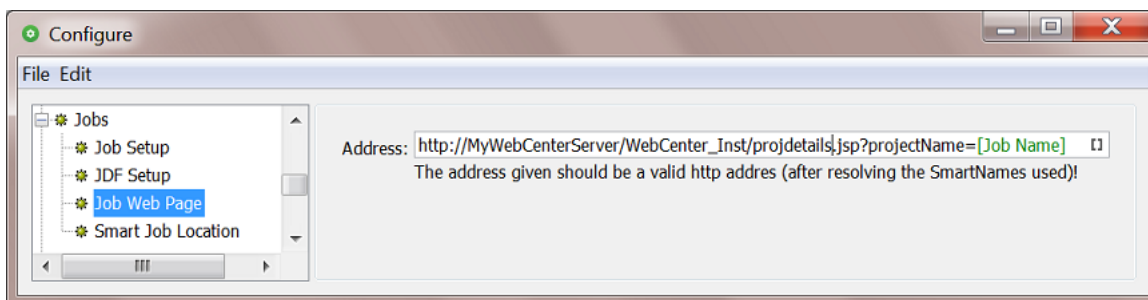

## Smart Job Location

### Concept

A **Smart Job Location** uses rules and SmartNames to define the location of a Job's job folder. This avoids having to enter this path manually when creating Jobs.

There are three types of specifications that you can use to set up the Smart Job Location. You can base the location on the **Customer** of that job, or on a custom **Rule** or you can specify (only) the **Container**.

These three methods are checked in a specific order: If no path is found based on the **Customer**, the set of custom rules will be checked. If there is still no valid path found for the job folder, then the **Container** setting will be checked.

The dialogs **'New Job'** and **'Job Setup'** offer the option to **Use the Smart Job Location Rules**. To see a preview of what the folder path will be, click on the button **"Show Job Location"** to see how the current rules create the path for this job. An example:

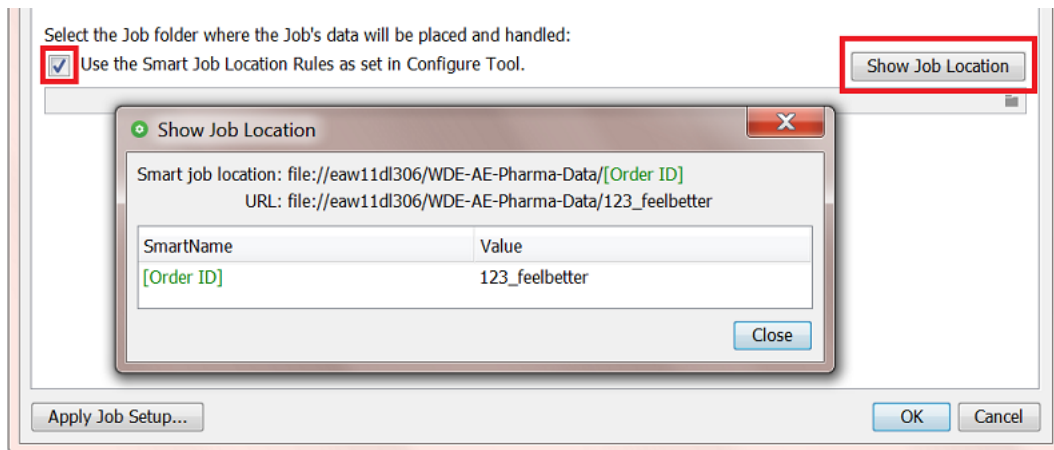

### Configuration

We now have a closer look at the types of specifications:

- [Customers](#)
- [Rules](#)
- [Container](#)



**Tip:** Also when using JDF to create Jobs, it is possible to use the concept of Smart Job Location as a SmartName for the indication of the folder for the Job in JDF: use <S JL \>.

### Customers

You can here define a root location for all jobs of a specific customer. An example:

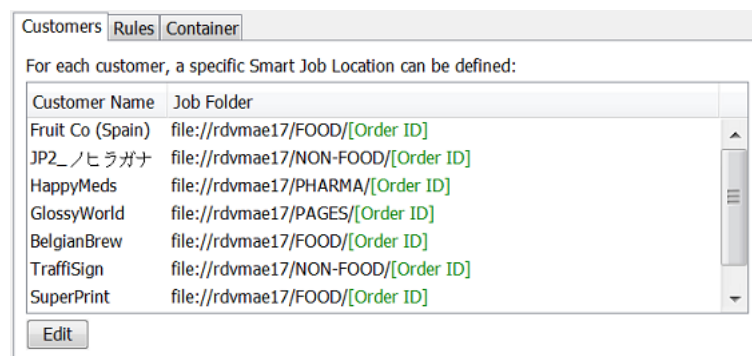

These settings also become part of the customer definition in **Tools > Customers**. An example:



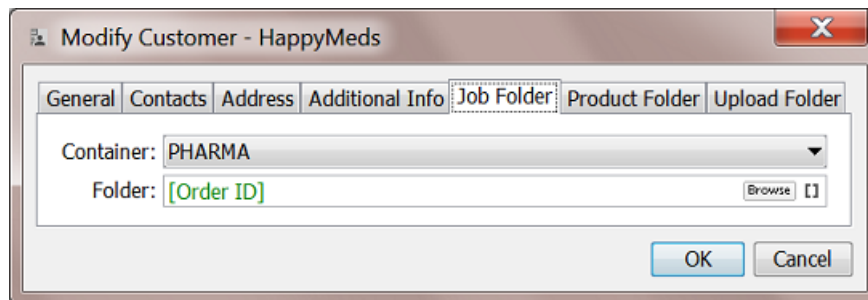

**Rules**

When no customer based setting was specified (or no valid location could be found), the systems checks if you did set any custom **Rules**.

These rules are based on conditions that use *Regular Expressions*. Click the **Help** button for a brief tutorial.

Here is an example where job folders are created in a specific root folder based on the number in their job's Order ID:

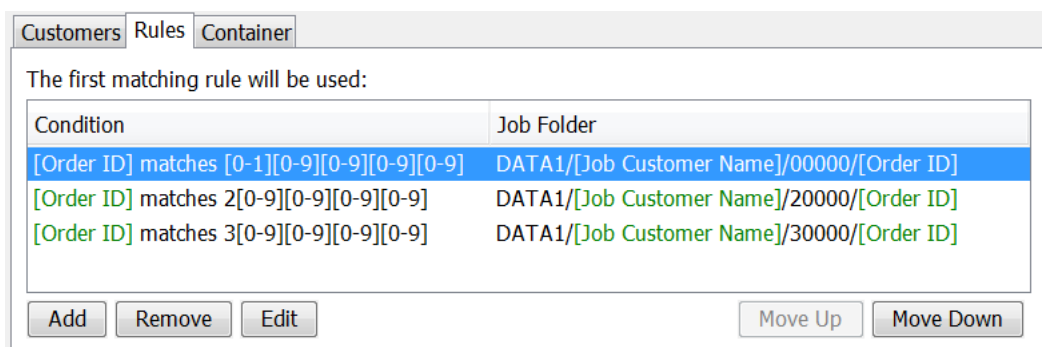
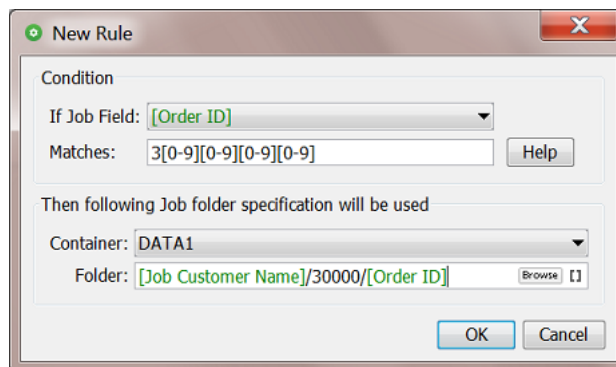

**Container**

When the checks on **Customers** and **Rules** did not return a valid path for a job folder, then the folder will be created in the here defined **Container**.

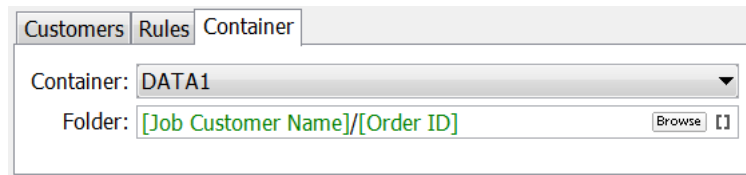

Here are two main use cases for this setting:

- Use it as a "Default Job Location". When you request a Smart Job Location, we always advise to at least here fill in a Container based location. This way, when none of the categories **Customers** or **Rules** result in a location, the system will use this setting, and not use a location that you can not control.
- This setting is useful when you have a system where you have all jobs created within one Container (a share on a hard disk) until that share has no more free space. You then create a next Container, change this setting to the new Container and you so use that one until it also fills up, etc.

## Locations

### Concept

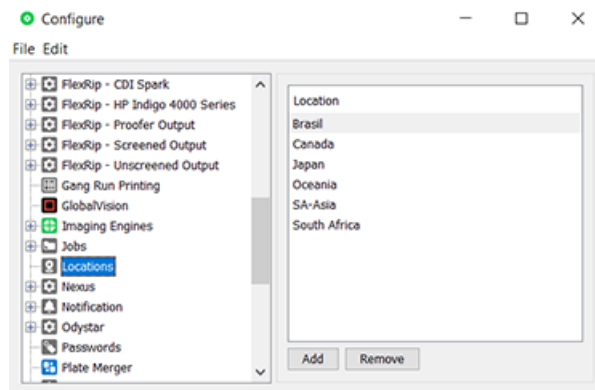

Locations are used for pre-filtering which Jobs, Products and related tasks or to-dos a user can see.

This tool was designed for SaaS setups where data was migrated from different on-premises Automation Engine's in the company. Learn more in [Filtering on Locations after consolidating all data](#) on page 1676.

### Working with Locations

- A location can be added as an attribute of a Job or Product.
- Members of a [user group](#) where this (and other) locations were defined as a filter will, in [My Workspace](#), only see Jobs or Products (and related tasks or to-dos) with that location attribute.



**Important:** To avoid problems when first starting with this type of filtering, users will also see data that has no location attribute set (yet).



**Note:** Views also offer a column showing this Location attribute.

## MIS

### Concept

The MIS prefix is a mandatory field when uploading Jobs, Products and related Customers to Esko Cloud.

Its purpose is to make sure that resource IDs on Esko Cloud are unique, especially when using multiple MIS or when combining resources from more than one Automation Engine server (often the case during migrations).

When storing and exchanging resources like Customers, Jobs or Products, it is crucial that they all have a unique ID.

An example: In the company group 'SuperPrint', 2 locations have an AE server that gets Jobs created from their own MIS. These 2 AE servers use Esko Cloud to store Jobs and do this under the same account. You now risk that both locations created a Job with ID 'J-1234' and that both are using a customer ID 'C-678' but referring to a different company. This prefix will prevent that these resources get mixed on Esko Cloud.

An MIS prefix can be maximum 7 characters long and may not contain special characters.

There are various use cases where this MIS prefix prevents clashes in resource IDs. Some are described in some detail below.



**Important:** An MIS prefix is not an **Agent Prefix**. An Agent prefix is also a tool that helps avoid clashes in resource IDs but is not related to using Esko Cloud. It is used in a specific setup where multiple locations that initially each have an AE that is integrated via JDF/JMF with their own local MIS then consolidate to 1 AE SaaS and still use those 2 local MIS systems. Learn more in [Multiple JDF/JMF MIS and 1 AE SaaS](#).

### Basic Behavior

When Automation Engine imports / downloads resources from Esko Cloud, it checks the MIS prefix they have in their name/ID.

- When it is equal to the one defined here in AE, it will be stripped off (here in AE).
- When it is not equal, the MIS prefix will be kept.



**Important:** NOW DOUBLE?? When a prefixed resource is downloaded from Esko Cloud (back) to an Automation Engine server, the AE checks if it is safe to strip off that prefix and if so it will do that. An example: When downloading a Job/Product the MIS prefix is stripped off from the Customer ID when the MIS prefix is the same as the prefix of the customer ID.



**Note:**  MIS Prefix:  A warning icon appears here when Automation Engine detects the use of Esko Cloud and there is no MIS prefix defined yet. In this case, also these tools or task will fail:

- the up/download tasks to Esko Cloud will fail in case the (related) customers are not linked
- the tool 'Import all customers from Esko Cloud'.

### Settings

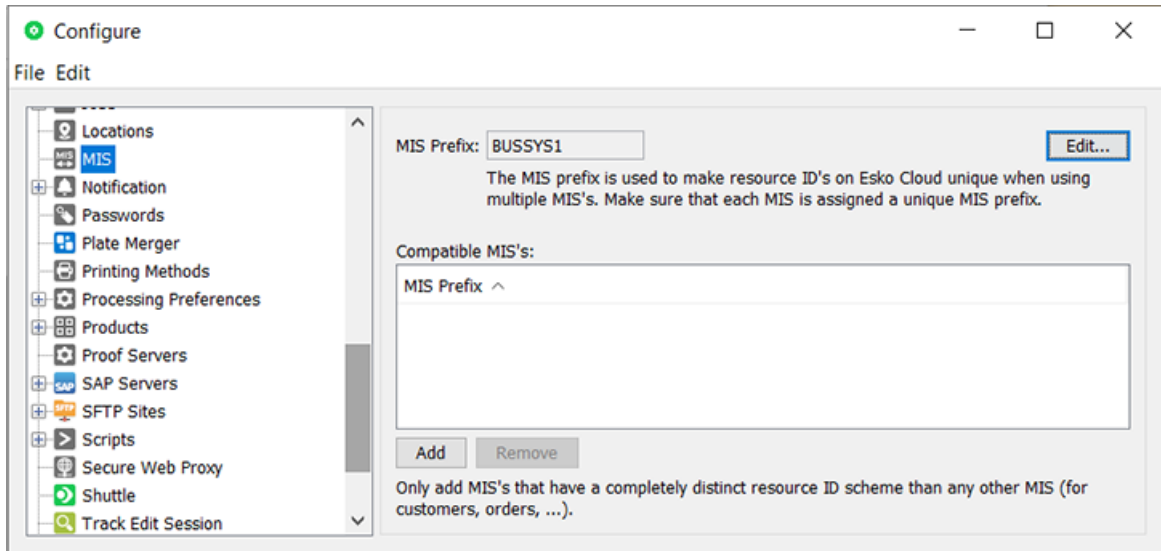

- **MIS Prefix:**

When you click **Edit...**, Automation Engine checks if there are Inactive Jobs on Esko Cloud that are using the current MIS prefix. (When the MIS prefix is empty, the cloud connection name (aka the 'Equipment name') is used as current MIS prefix)

- When there are no Inactive Jobs on Esko Cloud that use the current MIS prefix, you can fill in a new MIS prefix and click **OK**.

New Inactive Jobs and Customers on Esko Cloud will now be created using the new MIS prefix (the new MIS prefix is applied immediately, it is not necessary to save the configuration).

- When Inactive Jobs are found that use the current MIS prefix, you must decide to rename the existing Inactive Jobs or not.
  - **Apply the new prefix:** When choosing this, next to changing the MIS prefix on the Automation Engine server, a task is launched that renames the existing Inactive Jobs that were using the current MIS prefix.
  - **Leave the existing prefix:** In this case, only the MIS prefix on the Automation Engine server will be changed. No current Inactive Jobs will be renamed.

- **Compatible MIS:**

When you are sure that the data from multiple MIS will not generate any clashing IDs, you can here list them as 'safe', compatible MIS. For example: 1 always starts all IDs with the year of creation and the other one always ends the IDs with the year.

Once the configuration is saved, Inactive Jobs using the MIS prefix that was added can be moved to this Automation Engine.

**FAQs**

- Q: What if I have Esko Cloud resources from before this MIS prefix existed (before 23.07)?

A: Automation Engine will detect this and lead you to defining an MIS prefix and also lead you to the described panel where you have to choose to apply that new prefix to those resources. This action is then executed by a (hidden) task.

**Case 1 - An AE with an MIS connection uses Esko Cloud and migrates to SaaS**

Typically this kind of setup is one that changes over time:

1. Initially there is 1 AE on-premises integrated with its (local) MIS (in our example we name it *BusSys*). The MIS defines how the AE Jobs, Products and Customers are named.

For example in the Customers database, the ID 001 refers to the customer name *SuperPrint*.

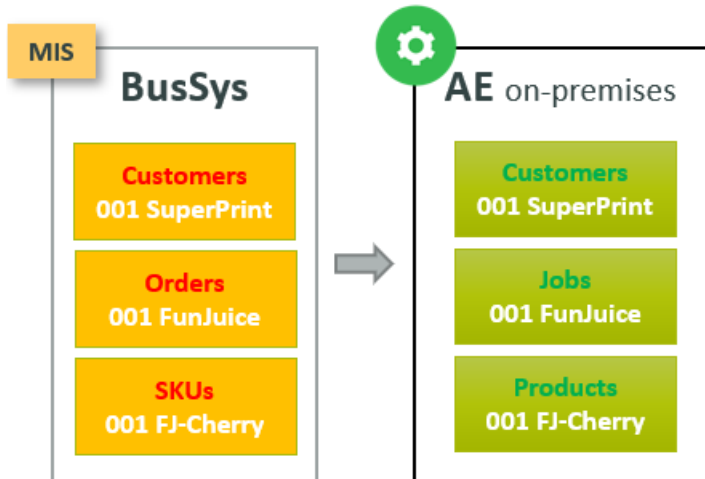

2. This customer wants to move to AE SaaS and starts using Esko Cloud to assist during that (data) migration. Esko Cloud organizes this data per its Esko Cloud account.

Notice how the IDs on Esko Cloud are now prefixed:

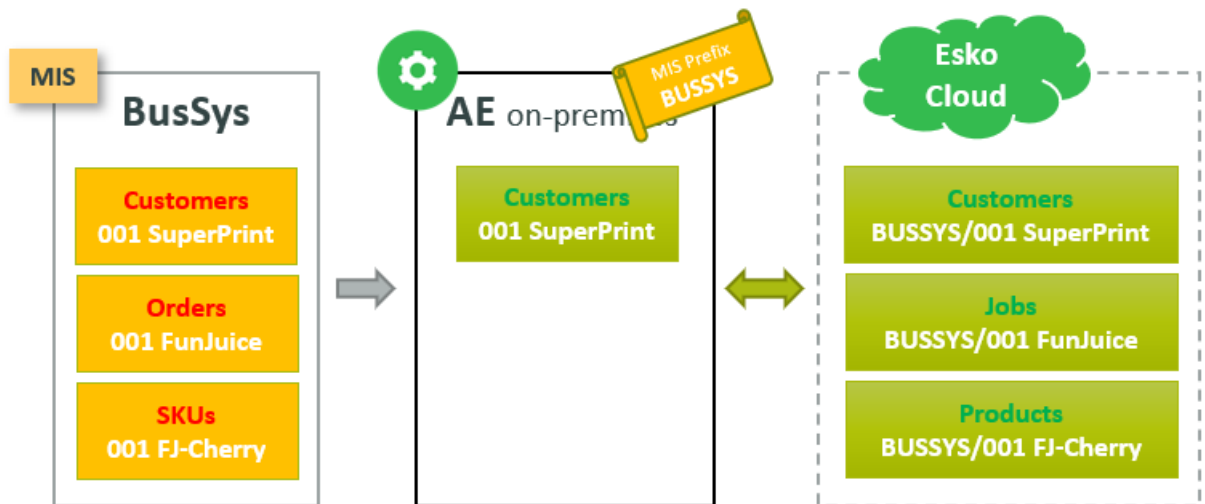

3. During a transition period, the customer uses both the AE on-premises and the new AE SaaS and both of them are integrated with the same MIS.

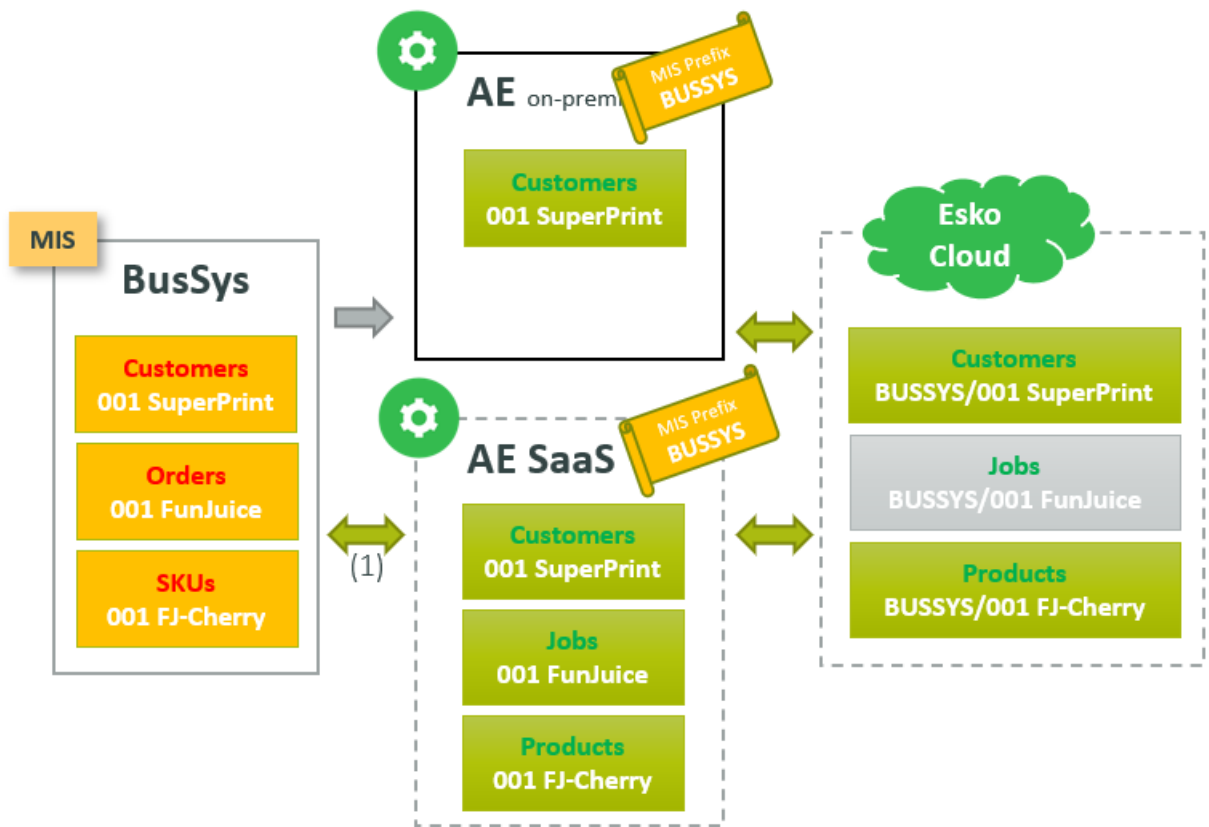

As long as they both use the same MIS prefix on their AE, the resources they put on Esko Cloud will be possible to upload/download between the two sites.

Notice how the Job FunJuice that is now downloaded to the AE SaaS server has the same ID and name as before ; its prefix was stripped off (because it was the same as the one set on this SaaS server). It is actually also still on Esko Cloud, as an Inactive Job.

4. Eventually, to complete the migration, the AE on-premises can be made redundant.

### Case 2 - An AE with a different MIS joins a setup of a 3rd MIS + AE + Esko Cloud

In this case, a double MIS setup is joined by an extra AE setup that uses another different MIS.

1. The initial setup is an AE SaaS that is already integrated with 2 different MIS.
  - (1) The MIS 'BusSys' is capable of connecting directly with the AE SaaS via JDF/JMF.
  - (2) The MIS 'Traxx' requires an AE Agent to communicate with AE SaaS and uses the *Agent prefix* TRX. On AE, this extra prefix already makes the resources they create on AE 'compatible', even before these resources exist Esko Cloud.

On AE SaaS, the MIS prefix was set to BUSTRX, a name to illustrate that these Esko Cloud resources could originate from either of those 2 MIS.

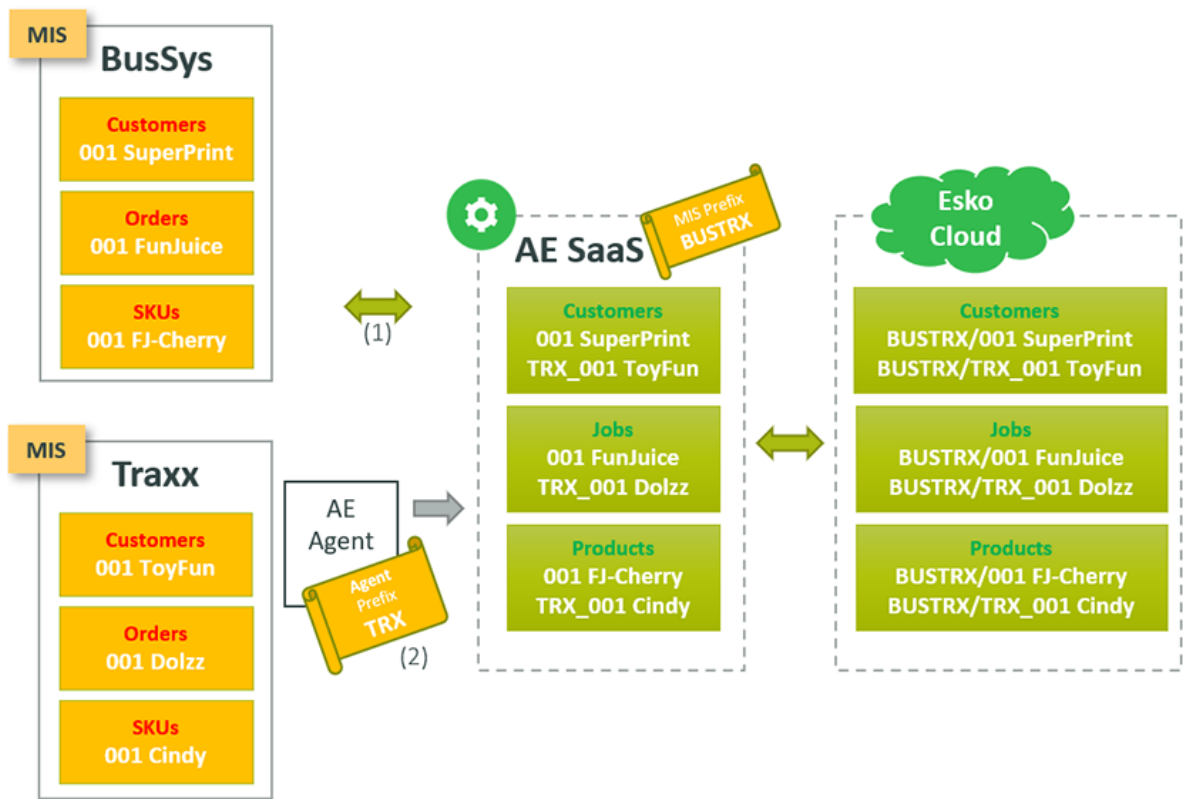

2. Then, another AE server enters this company's setup, one that was already integrated with another MIS. The resources it uploads to Esko Cloud are prefixed with `ROD`.
  - (1) The way the MIS 'Rodeo' names its resources is uniquely different from those integrated with the AE SaaS. This makes this MIS 'compatible'.

The result is that all resources on Esko Cloud can safely be exchanged to both AE setups.

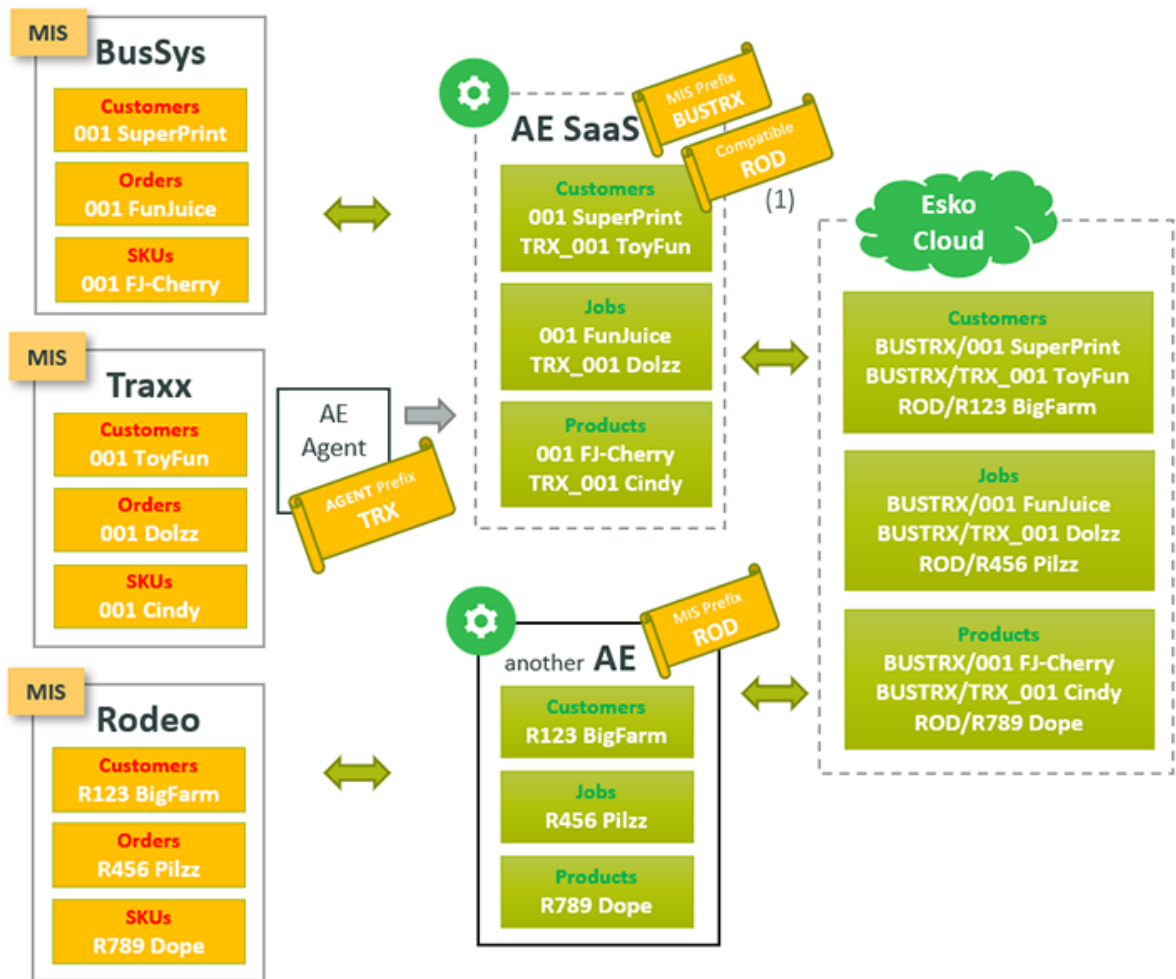

### Nexus

Learn more in [Integrating with Nexus \(outdated\)](#) on page 1961.

### Notification

Notifications are messages sent by Automation Engine (E-mail, .XML or .TXT files).



**Note:** For E-mail notifications, please check if the [Send E-mail task](#) is a better alternative.

The two tabs in this Configure item offer more advanced ways:

- [Rules](#).
- [Via File](#).

You can also use notification **Templates** to customize their content. Learn more in [Notification Templates](#).



### Notification Rules

Instead of defining notifications per ticket, you can define general notification **Rules**. You can set a notification rule for all or specific tasks or devices (queues).

You can define such rules for **Tasks** and for **Devices**.

For example:

- Writing an XML file every time a *Milestone task* ends.
- Writing an XML file of all actions on your CDI Compact device. Or have each notification added to the main XML for that CDI.



**Note:** Note that, for *CDI* and *Kongsberg* devices, the specific tools as described in their dedicated chapters may be a better alternative.



**Attention:** When you set a notification for both a device and for a task using that device, then only the one on task level will be executed.

### Creating a Notification Rule

1. Click **Add**.

The **Notification Rule Editor** opens.

2. Define the rule:

- **Condition**
  - Select one or multiple of the task statuses and select if this is the status of this single task type or of the whole workflow that this task belongs to as a step.
- **Action**
  - **Then:** Choose the type of notification.



**Tip:** If you want multiple types, create multiple notification rules.

- **E-mail:** Choose if you send it to the one who launched the task or type in E-mail address (when multiple, use a semicolon as separator). Select any attachments to the E-mail.



**Tip:** This is a good place to use SmartNames that pick up the E-mail address of the job's Customer Service Representative (Job setup) or any Customer contacts.

- **XML file:** Choose if you want a file per notification or if you want to add the information to an already existing XML file. For example: Adding all notification info related to a TIFF output device to one XML for each day (use SmartName [date] in the name of the XML file).

In the output field **Location**, minimally enter a name (use SmartNames). You can also define or browse to a specific folder to write the XML files into or you can leave this field empty and make the system use the default place for these files as defined in the next configuration item "[Via File](#)".

- **TXT file:** Same options as for XML files, but now you can also use templates to add custom text.



**Attention:** When, from the options offered in **Then**, you selected **Add XML / text data to file**, the field **Location** also needs a specification of the file name (not just its location). You can also use SmartNames to define that name.

- **Template:** Templates add custom made texts. Learn more in [Notification Templates](#) on page 228.



**Note:** The "Templates" list and the "Edit Templates" button are only shown when at least one template was created before.

**3. Click OK** to confirm and close.

Add more if you want to.

**Via File**

When setting up a notification rule that creates XML or TXT file, you can choose to not enter any output folder for these files, but only specify their name (learn more [here](#)). In that case, these files are written in the default place that you define in these tabs.

- **Tab "Text"**
  - **Append the message in a Log File:** When you choose to add the notification information to a same file. Browse to change its location and there create/select an empty file.
  - **Create a new file per message in a folder:** Define the folder where these notification text files will be created.

- **Tab "XML"**

Same as for TEXT files, but you can also choose to include the tasks messages (that appear in the task's "details") and the ticket parameters it used.

**Notification Templates**

A notification template can add custom text to the notification.

To create, modify or delete templates, click **Edit Templates...** in the **Notification Rule Editor**. Alternatively, go to **Pilot > Advanced > Edit Notification Templates...**

Learn more below in [Edit Notification Templates](#).

### Edit Notification Templates

#### Creating a template

1. Click **Add**.
2. The **Add** dialog pops up. Enter a name for the template. Click **OK**.
3. The **Edit Template** dialog pops up.

It has dedicated fields for **Subject** and **Message**, SmartName enabled.

The field for **Task Information** is best only changed on advise of Esko support. It includes code-based conditional information that can include the attachments you requested while [creating the notification rule](#).

Here is an example:

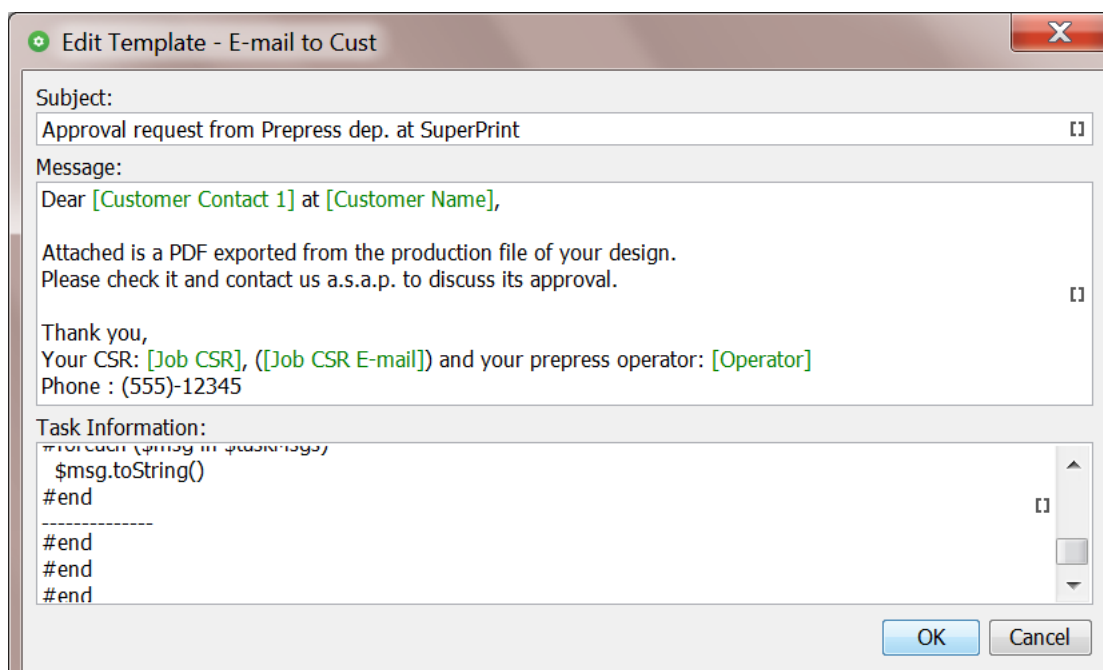

**Tip:** You can also **Edit Notification Templates** in the **Configure** tool, provided that you already have templates available: go to **Configure > Notification > Rules > Task/Device > Add...**

### Odystar

Learn more in [Integrating with Odystar \(outdated\)](#) on page 1961.

## Passwords

### Concept

The items in this section of the Configure tool are actually credentials: i.e. a combination of a user name and a password, and possibly more info.

The purpose is that you can then refer to these stored passwords from within task tickets that require some form of sign-in to another system.

This avoids having (possibly many) of such task tickets dependant on those credentials, which you might want to change regularly for security reasons.

Currently most tasks connecting to WebCenter allow to refer to these stored passwords.



**Note:** As with most items in this configure tool, you need administrator rights to manage this type of items.

### Adding a Stored Password

- Click **Add** or **+** to open the **Create new Password** dialog.
- **Name:** A name for this stored password. This is the name that will appear in the lists where a user will select it from.
- **User Name:** Account name used to sign in to the other system.
- **Password:** Password for that account to sign in to the other system.
- **Description:** Any extra information.
- Click **Create**.

An example result:

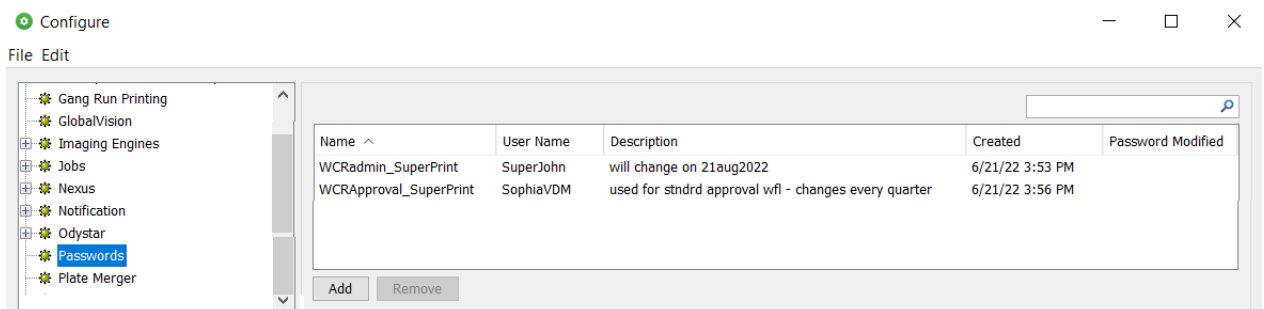

You can sort and filter this list.



**Note:** This data is stored in Automation Engine in an encrypted format. Also, when a ticket with a reference to a stored password is exported, it will not include this credentials information.

### Updating a Stored Password

The columns in this list also show when this stored password was **Created** and when it last had its **Password modified** (the actual password field).

To make changes to a stored password:

- Double click a stored password to open the **Update password Information** dialog.
- You can already change the **Name**, **User Name** and **Description**.
- Click **Change Password....**
- Enter a new password and click **Change Password**.

### Removing a Stored Password

- Select one or more stored passwords.
- Click **Remove**.
- You are asked to confirm. When confirming, these stored passwords will be removed.

### Proof Servers

This configuration is used to connect the Esko Proof Server which his required for

- the **Proof for Contract Approval** task (part of the Pack Proof product). Learn more in the [user guide of Pack Proof](#), in the page on 'Pack Proof Configuration'.
- the [Proof for Content Approval task](#) (part of the Imaging Engine product). Learn more in [Imaging Engine Configuration](#) on page 1253.

### Plate Merger

This item is documented in the chapter [Flexo CTP Device Workflow](#). Find a direct link [here](#).

### Preflight Tools



**Important:** This item served to link Automation Engine to external preflight server software that you can then use in the [Preflight via External Application](#) task. However, in AE v16, this task was declared to become 'Soon Outdated'. Learn more about this concept and your alternative in [Concept of \(Soon\) Outdated Tasks / Features](#) on page 531.



**Important:** When you want to use Enfocus PitStop, we advise to use the version that is built into Automation Engine. This is done when you use the task [Preflight with PitStop](#).

Below is valid when you have a reason to still work with that separate install of PitStop Server:



**Important:**

- This external preflight server software (for example a separate install of PitStop Server) has to run on your Automation Engine server.
- You must share the folder containing the profiles (for example PitStop's C:\Program Files\Enfocus\Enfocus PitStop Server 13) to be able to access it from the Preflight ticket.

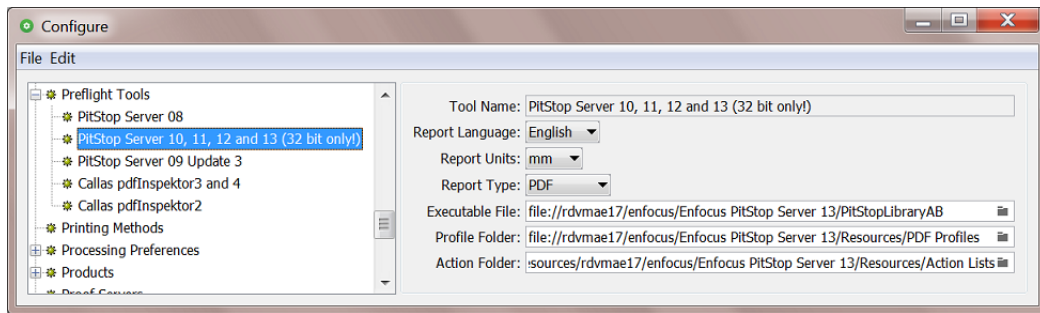

**Tool Name:** Select one of the supported preflight applications.

**Report Language:** Select the language you want the report to be in. For Enfocus PitStop Server, you can set this in the PitStop Server preferences.

**Report Units:** Select the units to be used in the preflight report.

**Report Type:** Select the type of report: PDF, XML or both.

**Executable File:** Enter (browse to) the path to the preflight application's executable file.

**Profile Folder:** Enter (browse to) the path to the folder where the default profiles for the selected preflight tool are stored.

**Action Folder:** Enter (browse to) the path to the folder where the action lists for the selected preflight tool are stored. The Preflight task will allow you to select multiple actions from this folder.

## Printing Methods

**Printing Methods** are defined here in the Configure tool. You get a list of standard names. You can add custom ones.

You can set an ink to a specific printing method by using the Job setup's *Inks tab* or by using a one of these 'Classic' tasks: [Adjust PDF Screening](#), [Extract Inks](#), [Normalize PDF File](#), [Normalize PS / PDF / AI 8.0 File](#), [Optimize PDF Separations](#), [Trap with PowerTrapper](#) and when *RIP'ing with Imaging Engine*.

For example:

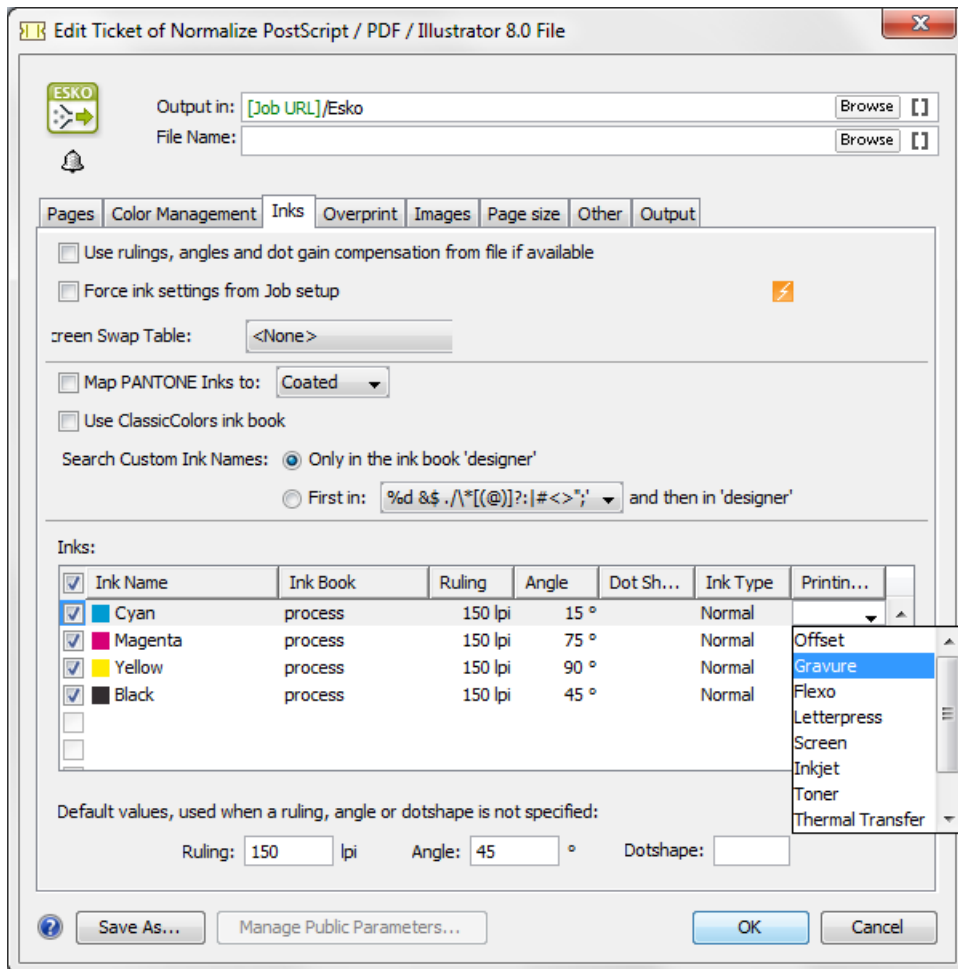

These are typical examples of how to make use of a **Printing Method**:

- In your **Imaging Engine** (RIP) task for a flexo device, you select only the inks of printing method 'flexo'.
- You make a special ReportMaker PDF that focusses on the 'ink' used for embossing. In your workflow, you use the [Extract Inks \(Classic\)](#) task to select the wanted ink type before you start the ReportMaker (Classic) task.

## Processing Preferences

- **PDF+ Processing**

All PDF+ files require to have a document profile.



**Note:** Learn about PDF+ files in [PDF+ in Automation Engine](#) on page 52.

- **Default Document Profile:**

When Automation Engine runs a task on a PDF+ file (one that uses the PDF Action List Processor, see below), it will set the PDF+ file's document profile to the one selected here.

When the PDF+ file did not have a profile yet, it will be set to the one defined here.

When the PDF+ file already had another a profile, it will be changed to the one defined here.



**Note:** In Automation Engine, this is the only place where you can define this default document profile for PDF+ files.



**Note:** Tasks that set this document profile are those using the PDF Action List Processor (PAL):

- The tasks [Optimize PDF](#), [Apply PDF Action List](#) and [Trap](#).
- The Step & Repeat tasks (excluding the 'Classic' ones) set this profile if there is no profile in the one-ups. If any input file has a profile, the first one is used.
- Any VDP expansion also adds this profile to the expanded data.

Learn more in [Which AE task Uses which Technology?](#) on page 66.

• **Automatic Normalization**

Tasks that [require Normalized PDF files](#) as input will automatically normalize any native PDF you launch them on. This hidden and automatic normalization is using the here defined task ticket.

By default, Automation Engine uses the [Normalize PostScript/PDF/Illustrator 8.0 File \(Classic\)](#) task ticket named "**OnDemand**".

From this ticket only the settings in the **Color Management** tab are taken into account.

All other settings of the automatic normalization are forced to fixed default settings. For example, automatic normalization will always embed all images.

• **Embedded Images**

Normalized PDF files have the ability to save all their images internally, but this may result in oversized files. You can define the maximum size for internal images here.

Images exceeding the defined size will be saved externally.

**Products**



**Tip:** Automation Engine Products are documented in the dedicated chapter [Products](#) on page 594.

**Product Setup**

In the item **Product Setup**, you can name the custom fields that appear in the [Product Setup](#) and in the [Product Part Setup](#).



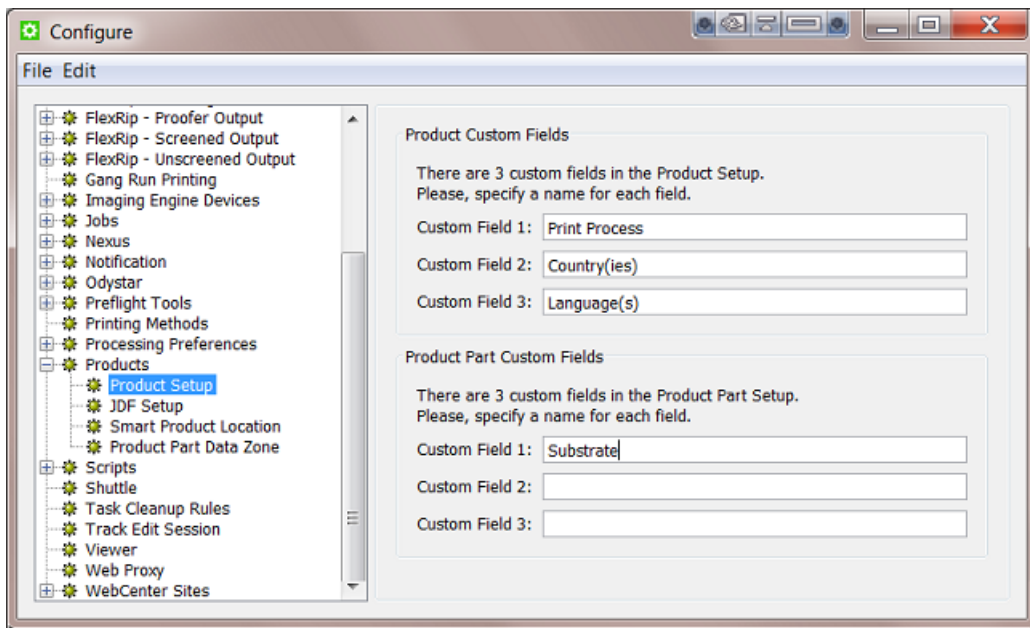

Above example configuration results in this:

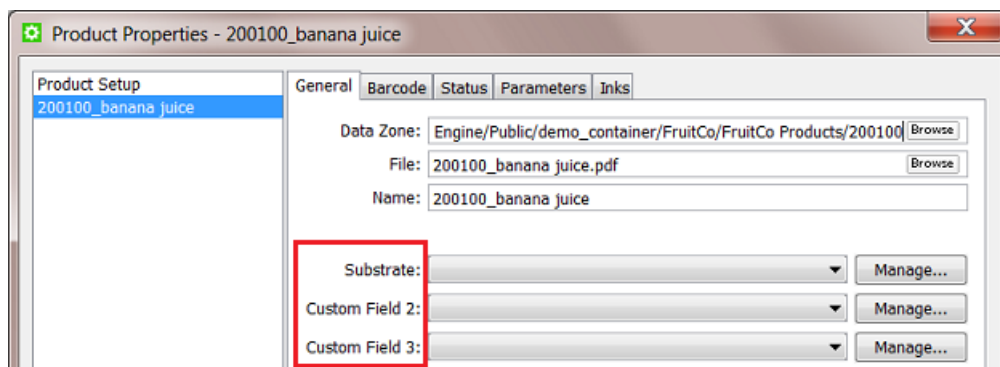
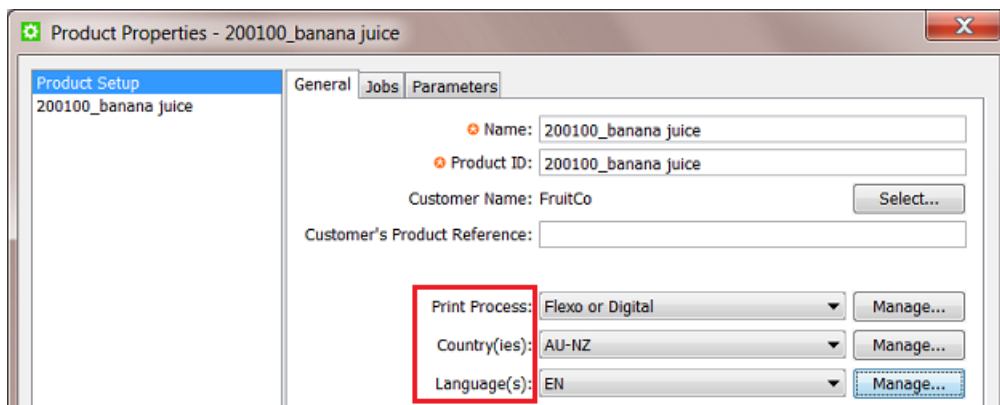

### JDF Setup



**Note:** JDF workflows are not documented in this user manual. Learn more about the basics of JDF in the chapter [Integrating with External Systems](#) on page 1769. For more information, contact Esko Solution Services.

### General

When you work with JDF, decide here if you want to **Enable automatic product creation via JDF**.

### Data Zone



**Note:** The **Data Zone** concept is documented in [Products Data Structure](#) on page 599.

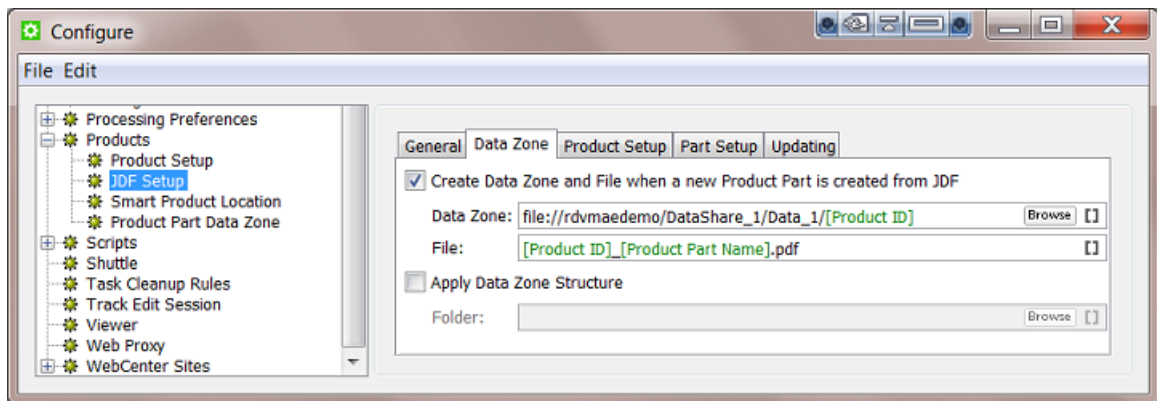

- **Create Data Zone and File when a new Product Part is created from JDF:**
  - **Data Zone:** When the JDF references a non-existing product part, define here where to create the data zone for that product part (the physical folder containing the part's file).
  - **File:** When the JDF references a non-existing product part, define here where to create the subfolder and/or file in the data zone.
- **Apply Data Zone Structure:** Use this option when you want to add a specific substructure to the data zone. Browse to an example data zone (folder with subfolders).

### Product (Part) Setup

In the **Product Setup** and **Part Setup** tabs, you can add rules to map values from the JDF onto the attributes of the products that the JDF creates.

To do this, type an XPath expression into the field for each attribute that should be overruled by the system value, or click **Edit** to open the XPath builder.



**Note:**

- The JDF that was loaded in the XPath builder is remembered while the Configure dialog is open.
- When editing the next XPath, the same JDF will automatically be used as the example XML in the XPath builder.

Learn more about using XPath in [XPath Builder](#) on page 215.

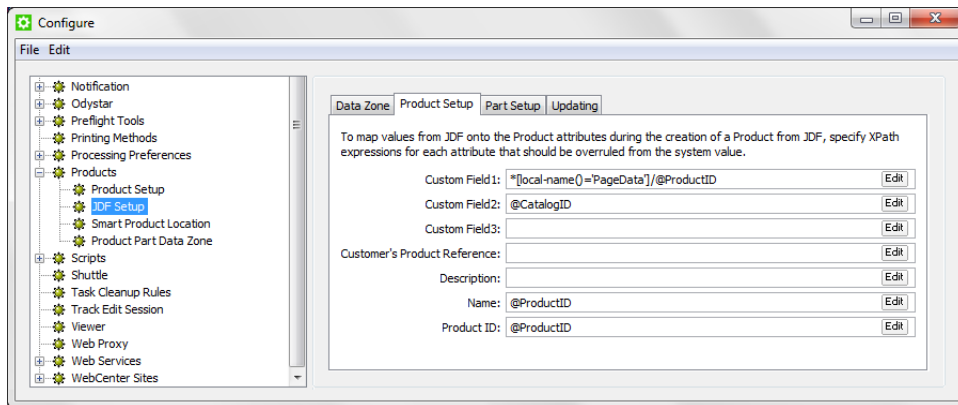

**Updating**

In the **Updating** tab, indicate what should happen when an existing product is updated over JDF.

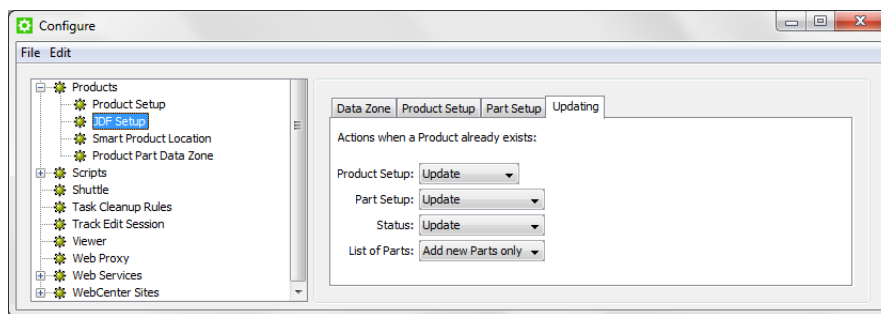

Learn more about updating products in [Task 'Add to Products'](#) on page 626.

**XPath Builder**

**Concept**

When you click **Edit** in any field that allows XPath Expressions, the **XPath Builder** opens.

The XPath Builder offers alternative starting points:

- The XPath is not resolved relative to the root node of the XML document, but from another XML element.
- When a proper JDF is used as the example XML, a list of possible starting points is generated.

- While the XPath builder automatically selects the appropriate starting point, it is still possible to manually change the starting point by clicking on another node while holding down **Command** (Mac) or **CTRL** (Windows).

**Example**

See an example where the XPath builder is used to create an XPath for a product part attribute:

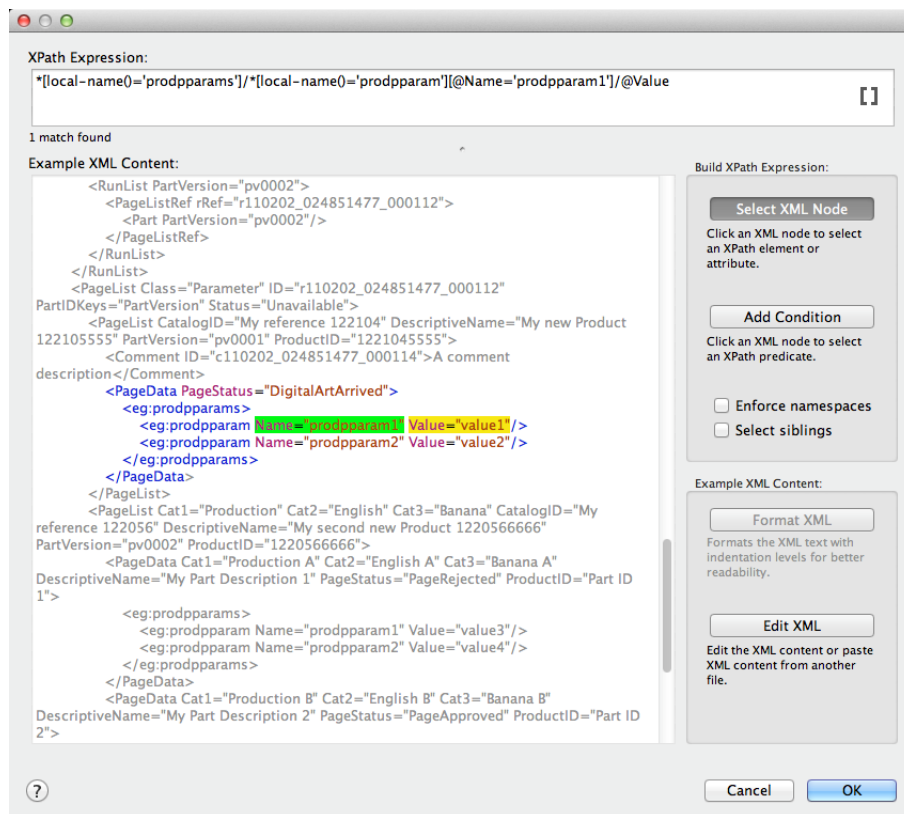

- The XPath builder automatically uses the first PageData node as starting point. This is visualised by showing the content outside the PageData node in grey.
- It is still possible to select nodes outside the PageData node as result node or as predicate node.
- When selecting nodes outside the PageData node, the XPath builder will create absolute XPaths.
- When you want, you can modify these absolute paths by making them relative to the PageData node using `../`

**Smart Product Location**

Smart Product Location allows to automatically decide the location for a new product based on a set of rules defined in **Configure > Products > Smart Product Location**.

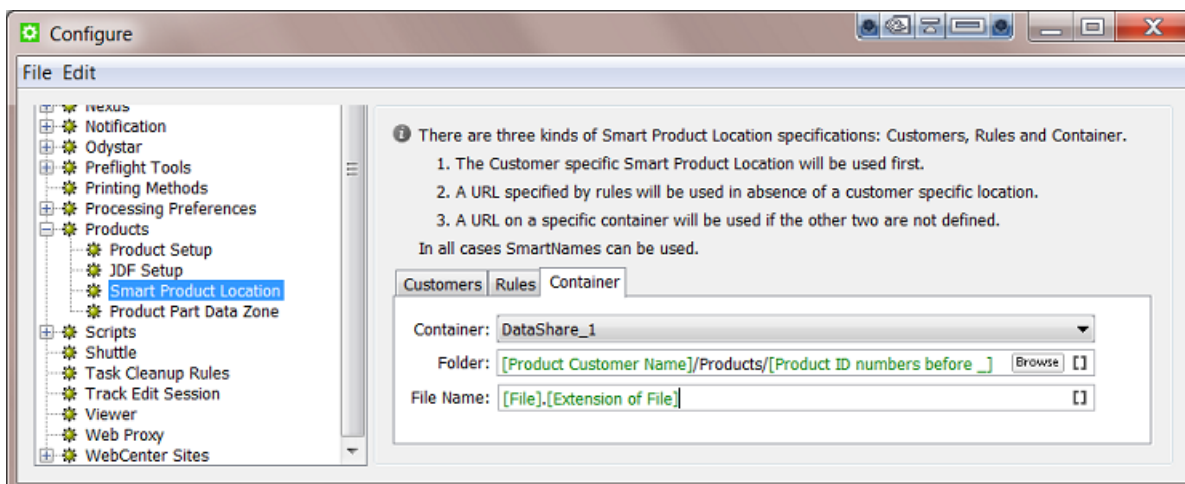

Learn more about creating products in [Creating Products](#) and about their file location settings in [Product \(Part\) Properties](#) on page 611.



**Important:** You do not need this tool when your file is already in the right place when you make it a product part.

### Three Ways to Decide the Location

You can use three kinds of specifications to set up the Smart Product Location: based on **Customers**, on custom **Rules** and on a chosen **Container**.

These three ways are checked in a specific order: if the **Customers** check does not return a valid path, then **Rules** will be checked. If this still does not return a valid path, then the **Container** rule will be used.

- **Customers:** This rule allows to specify per customer a SmartName based path where all its products will be created.
- **Rules:** This tab allows to set extensive conditional rules. For example you could create all the products in a structure based on their [custom field 1]. You can create several rules and they will be checked from top to bottom.
- **Container:** This tab allows to set a smart path in a fixed Container where all products will be created (from now on). For example: All products are created in Container Data1 and when the disk of that Container is full, you change the configuration so that from now all new products will be created in Container Data2.

### Using the Smart Product Location

Smart Product Location is used in these cases:

- When choosing [Uploading As a New Product](#) on page 617. This feature is used for example when your product data is still on a CD or on your desktop.
- When creating products via JDF or when placing products via JDF (a product part URL is already decided but 'empty' and the JDF then delivers the file to the URL that expects the file).

When [Uploading a File as a Product](#), the panel shows the extra Smart Product Location tool at the bottom:

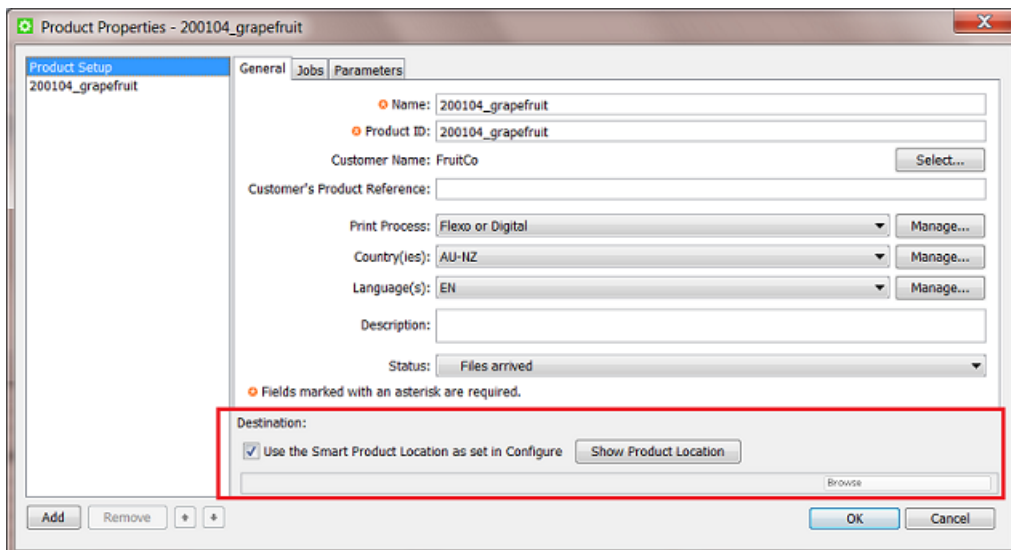

Click **Show Product Location** to see a preview of where the uploaded file will be placed. An example:

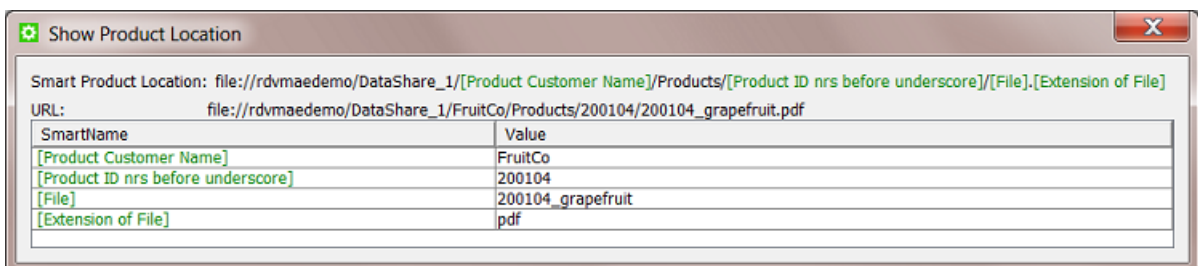

### Product Part Data Zone



**Note:** Learn about the concept of **Data Zone** and see some examples in [Products Data Structure](#) on page 599.

Every product part has a data zone. It contains the product part file itself and any additional related files.

When you look at a product's data zone in the Pilot, the depth of the data zone indicates the number of folders that you will see between the root of the data zone and the folder containing the actual product part file.

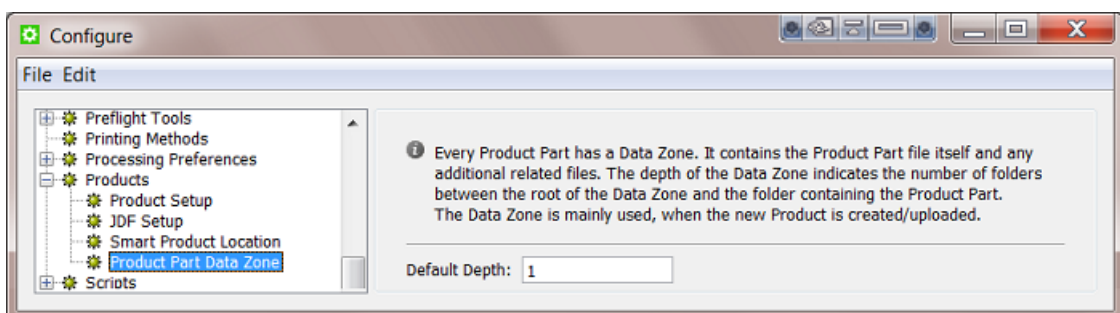

The **Default Depth** value that you enter here is used when you create or change the product part properties.

### SAP Servers

Configuring an SAP server is required when integrating with such a system. Learn more in [Task 'Interact with SAP'](#) on page 1846.

### SFTP sites

SFTP sites are used in the [Upload via SFTP task](#) and also by an [SFTP Access Point](#). Learn more about SFTP in the documentation pages of those tools or in this [online article describing the difference between FTPS and SFTP](#).

To configure an SFTP site (an SSH server), open the Configure tool, select the topic **SFTP Sites** and choose **File > New**. A default name appears, click and wait to change it. It is good practice to add both the host server and the user in the name.

#### Settings

- **Server:** The name of the SFTP server.
- **User Name:** The name of the user logging in to that SFTP server.
- Authenticating with an SFTP server requires a valid SSH account (`username@host`) and one or both of these authentication methods:
  - a valid password
  - a pair of public-private key files, as generated by an SSH-keygen tool.

An SSH private key authentication enables a higher level of security (it for example avoids bots trying out all user/passwords). These keys come in pairs, a public and a private key.



**Note:** In the rare case where the SFTP server was set to accept both types of authentication, you can enter both a password and a private key. The system then first checks the password method, and when that fails, it tries the keys.

- When using a **password**, enter the password.
- When (also) using a **Private Key**, use **Select...** to upload the private SSH key file into the Automation Engine database. Optionally, fill in the **Passphrase** (to be able to unlock the key).



**Note:** When the public-private key pair authentication is used, the public key must be added to the authorized keys of the SFTP server and the private key must be selected in this configure tool.

**Clear** serves to remove a prior selected key from the Automation Engine database.

- **Test Connection.** Always test before saving this configuration.

### Secure Web Proxy

Learn about using web proxy settings in [the page on the item Web Proxy](#).

This item is where you add proxy settings when the communication is https (not http).

## Scripts

[This dedicated chapter about Scripting](#) explains how Automation Engine can run custom scripts and so help automate desktop applications.

Learn more about its configuration in [this page on configuring the Script Runner tool](#).

## Shuttle

Working with Shuttle is described in [its dedicated chapter](#).

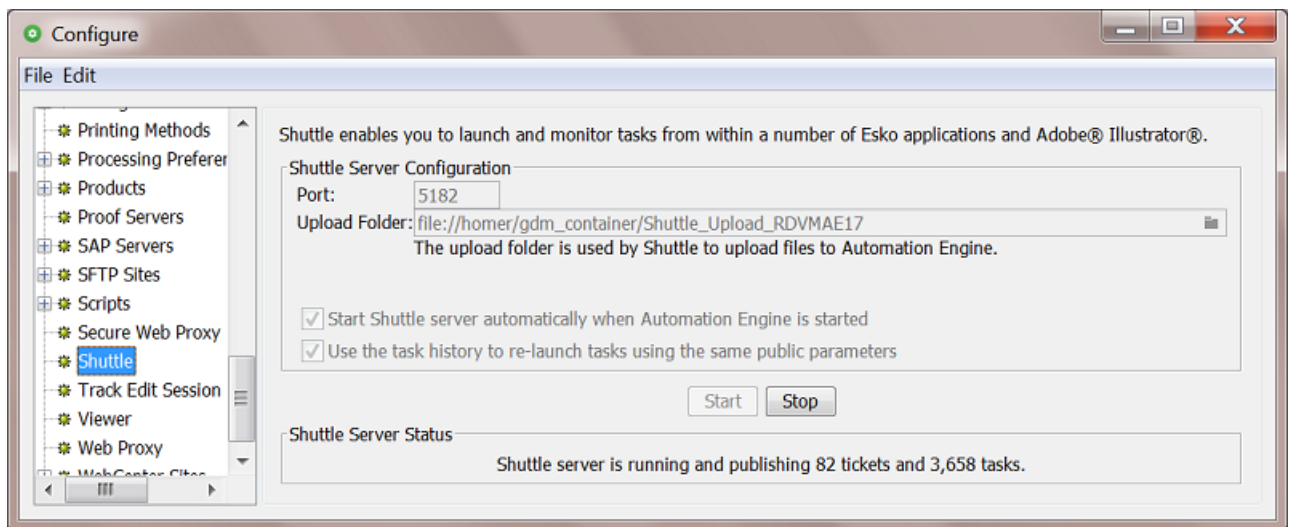

Enter the **Port** to use for communication between your Automation Engine server and the Shuttle clients.



**Note:** By default this is port 5182, but if this port is already used by other processes, you should enter the next available port.

Click  to define the **Upload Folder**. This is where Shuttle clients will upload files that are not located in a Container.



**Attention:** However you use Shuttle, it is **mandatory** to specify an upload folder! If not you might get this error:

```
The spool folder does not exist on the server.
```



**Note:** The upload folder must be located in a Container.

- Select **Start Shuttle server automatically when Automation Engine is started** if you plan to make frequent use of the Shuttle technology.
- Select **Use the task history to re-launch tasks using the same public parameters** if you want Shuttle to remember the public parameter values that were used when submitting a file. If you then re-submit that file, these values will be automatically filled out.



Click the **Start** button to start Shuttle server. This is not required to use the Shuttle application. However, starting the server is required to use Shuttle via 'Classic' applications like ArtPro, PackEdge and Adobe Illustrator. Shuttle server makes Automation Engine's workflows, tasks and files accessible to the Shuttle clients.

Save the settings by clicking **File > Save**.

### Shuttle Server Status

This shows whether the Shuttle server is running and how many tasks it manages.

### Track Edit Session

When you open a file that resides in an active Job (folder) in an Esko editor, the [Track Edit Session](#) task can automatically start logging times and several editing actions. This tracking stops when the file is closed.

You can here select for which editors you want to (automatically) run this task.

Learn more in the page about the [Track Edit Session task](#).



**Note:** When changing this configuration, restart the editor to activate this behavior.

## Viewer

### Concept



**Note:** Learn about the Viewer in [Automation Engine Viewer](#) on page 1077.

The Viewer can show many different file formats. It can also use different graphic engines to interpret these files, which can lead to small differences in the displayed colors. You here define which graphic engine the viewer should use and also set some other preferences. Learn more about graphic engines in the chapter [PDF Formats and Metadata](#) on page 44.



**Important:** Comparing in the Viewer requires both files to use the same viewer technology.

These settings are not only used by the Viewer but also by the tasks that create view data ('Prepare for Viewing' and 'Publish on WebCenter').



**Restriction:** These tasks do not support the 'ArtPro+ latest viewer technology'. When this technology is requested here in this panel, these tasks will fall back on the 'ArtPro+ viewer old technology'. Learn more about these technologies below.



**Note:** Some Imaging Engine tasks also prepare view data. However, those tasks do not start from the PDF nor do they use a graphics engine ; they start from the RIP'ed data which is why those tasks do not use the settings in this panel.

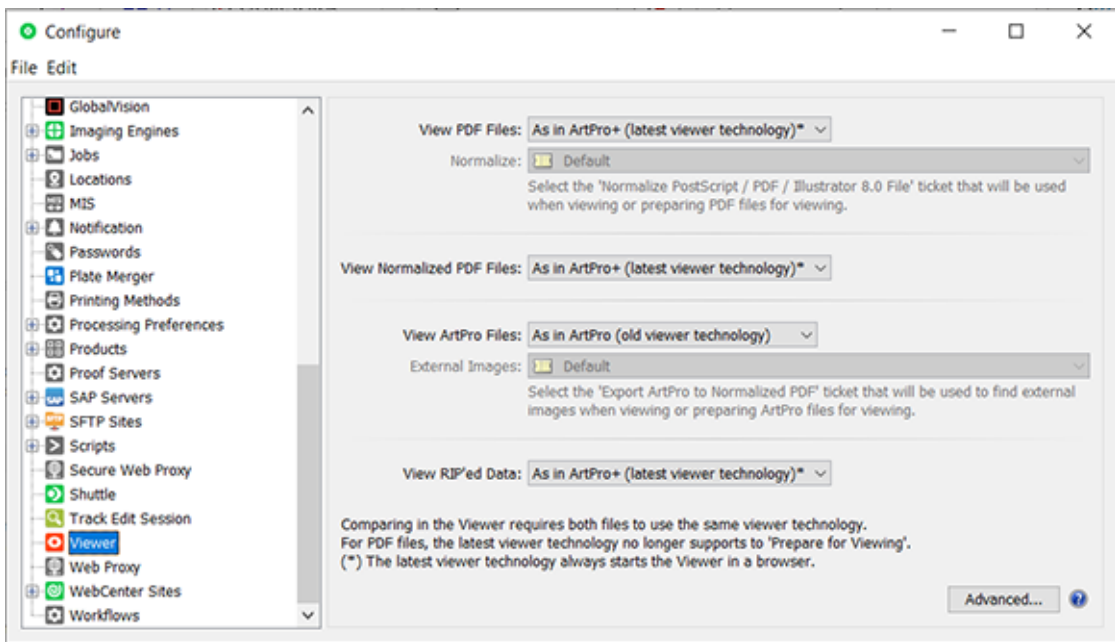

### Configuration Settings

- **View PDF Files**

- **As in ArtPro+:** By default, the Viewer shows PDF files as they are shown in ArtPro+. This means that the graphic engine of ArtPro+ (NDL) interprets the PDF and defines the viewing data.

This view mode can be used for native PDF (which includes PDF+), normalized PDF, Plato Step & Repeat PDF and Plato Station files.

- **As in ArtPro+ (latest viewer technology)\*:** In this case, the PDF data is converted to separations and the separations to RGB using the latest and same color management as used in ArtPro+. This also means that you can make use the PDF's on board "output intent" or another specified ICC profile.



**Note:** This does not make this Viewer into a soft-proofing solution. The technology (always) uses 'sRGB' as color space and assumes the browser/monitor is calibrated for 'sRGB'.

This mode always starts the viewer in a browser (i.e. not in a Pilot).



**Restriction:** For PDF files, this latest viewer technology no longer supports to 'Prepare for Viewing'.

Since AE v23, this mode is the default mode for new installations. Upgrades to AE v23 will keep the previously chosen mode (which since v23 is referred to as 'old viewer technology').

- **As in ArtPro+ (old viewer technology):** In this case the PDF data is converted to separations in the same way as in ArtPro+, but the separations are converted to RGB using old color management technology..



**Attention:** When a PDF file is opened in the Viewer, and when the Viewer is *configured* to view PDF Files "As in ArtPro+", then this PDF file will be locked ; it can then not be renamed or deleted until it is closed in the Viewer.

- **As in PackEdge (old viewer technology):** Select this mode when you want the Viewer to show the data as you see them in the classic editor PackEdge (the BRIX technology).



**Restriction:** This mode opens a Viewer that offers less functionality. The BRIX technology also does not support layers, processing steps or screen sets.

In PackEdge, the default file format is normalized PDF, so when choosing this mode for native PDF, you are also asked to select the normalization ticket that will be used in background when you open non-normalized files (native PDF(+), AI or (E)PS files).



**Note:** When this was your choice before upgrading to a new version, it will of course be kept.

- **View Normalized PDF Files**

- **As in ArtPro+ (latest viewer technology)\*:** As described above for native PDF files, this will show you this file as if you opened in ArtPro+.
- **As in ArtPro+ (old viewer technology):** As described above for native PDF files, this will show you this file as if you opened in a version of ArtPro+ but using an older version of color management.
- **As in PackEdge (old viewer technology):** As described above, the graphic engine BRIX is used. This mode enables for example to see the inks / separations of a normalized file in the same way as they are shown in PackEdge.

- **View ArtPro Files**

- **As in ArtPro (old viewer technology):** The graphic engine of the classic editor ArtPro is used. This mode is advised for ArtPro users who do not work with normalized PDF files in their workflow.
- **As in PackEdge (old viewer technology):** The graphic engine BRIX is used. This mode will normalize the ArtPro native file before creating the view data. This mode is advised when you want to compare ArtPro files with normalized PDF files. Some users might prefer this mode because it was used in earlier versions. Before v14.1 of Automation Engine, this was the default mode.

**External Images:** Select the ticket of the task [Export ArtPro to Normalized PDF \(classic\)](#) that has the correct settings so that the Viewer finds the external images in that ArtPro file.

- **Viewing RIP'ed Data.** RIP'ed data always need to 'prepared for Viewing' first.

- **As in ArtPro+ (latest viewer technology)\*:** The data is prepared using this latest technology.
- **As in PackEdge (old viewer technology):** The data is prepared using this older technology.

Learn more about viewing RIP'ed data in [Working with RIP data](#) on page 1133.

- **Advanced**

- **Viewing Preferences**

- **Anti-aliasing:** Select this to smooth the staircase effect that you can get when pixels represent line art objects.
- **Merge similar inks:** Select this to merge inks with the same name that have a different ruling or angle. They then appear as one same channel in the Viewer.



**Attention:** We strongly advise to enable this option when viewing ArtPro files or Normalized PDF files generated by ArtPro.

- **Speed up for Viewing**

Choose the ticket that the "Speed up for Viewing" folders should use. Learn more in [Speed Up For Viewing](#) on page 1131.

## Web Proxy

For tools where Automation Engine uses http communication, you can here configure details of the Web Proxy to use.

- **Web Proxy Server:** Specify the computer name or IP address and port of the proxy server.
- **Proxy server requires a password:** When the proxy server requires authentication, specify the **User Name** and **Password** to use to authenticate.
- **Bypass proxy settings:** Specify a list of patterns separated by '|', The patterns may start or end with a '\*' for wildcards.



**Attention:** You need to restart Automation Engine before its tools start to use the web proxy for http communication.

These Automation Engine tools use web proxy settings for http communication:

- Tasks: [Create or Modify WebCenter Project](#), [Download WebCenter Document](#), [Integrate with WebCenter](#), [Publish on WebCenter](#), [Interact with Web Service](#).
- Cloud applications and storage tools, configured in [External Web Services](#) on page 199.
- [Connection Doctor](#), to troubleshoot the server.
- In the [Server Web page - Server Admin - Server Checks - Network](#), the **Online help** check and the **WebCenter Sites** check.
- Automation Engine's JDF Server (JMF), used to communicate with devices and external systems.

## WebCenter Sites

Go to **Tools > Configure > WebCenter Sites** to configure links from Automation Engine to WebCenter sites.

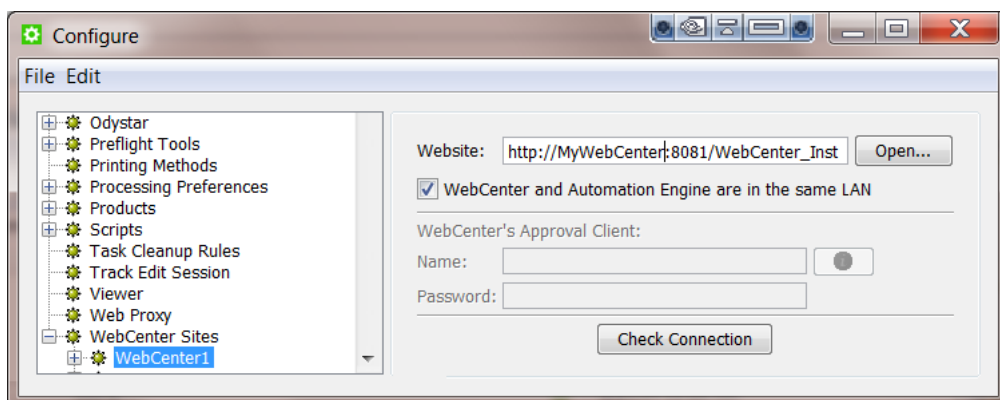

- **Website:**

Specify the web address of the WebCenter site. After you entered the WebCenter address, click **Open...** to check if the WebCenter site is up and running. If you are redirected to the login page, it means that the address is correct and that the site is up and running.



**Tip:** Be aware that this address is also the address that will be included in the notification e-mails when adding links to documents (approval cycle start E-mail). You should therefore make sure that the address can be accessed from the outside. Make sure to not use an internal address, but one that you want your (external) users to use when they use WebCenter.

- **WebCenter and Automation Engine are in the same LAN**

Select this toggle if this is true. This will most likely be the case. Deselect this toggle if WebCenter and Automation Engine are not in the same LAN.



**Note:** How can you verify if these two systems are in the same LAN? They are in the same LAN when you can connect from WebCenter's application server, this is the system where JBOSS is installed, to an Automation Engine Job Folder with the credentials of the **System Account** (by default the user BGSYSTEM or the one you changed it to, using [the System Account page in the Server Admin web page](#)).

- **WebCenter's Approval Client:**

If WebCenter and Automation Engine are not in the same LAN, you first need to create an Automation Engine **Approval Client** in WebCenter. This is necessary to give Automation Engine permissions to listen to the approval messages that are stored in WebCenter.



**Tip:** If the **Approval Client** does not exist yet, follow these steps:

1. In WebCenter, log in as **Administrator**.
2. Go to the **Admin** section. In **Configurations**, select **Workflow and Tunnel Approval Clients**.
3. Click the link "**New Workflow and Tunnel Approval Client**".
4. Enter a **User name** and a **Password** for the Automation Engine client. Mind that this is also the user name and password that have to be entered when configuring the WebCenter site in Automation Engine.

Fill out the client **Name** and **Password** and click the **Check Connection** button. This will check if the user can log on successfully.

The **Info** button displays the following information: *"In case Automation Engine and WebCenter are not in the same local area network (LAN), the retrieval of the approval results is secured by a name and password. The name and password specified in Automation Engine must match the name and password specified in WebCenter by the WebCenter administrator. When clicking the 'Check' button, the WebCenter version will be checked and the name and password will be validated by WebCenter."*

- **Check Connection**

When you click this button, you should, after a few seconds, get a window saying "**Check OK**". The software version of that WebCenter will also be mentioned.



**Note:** The button will check the validity of the user name or password to connect to that WebCenter but **not** of your WebCenter's **Approval Client**.



**Note:** Passwords are encrypted.



**Note:** When you connect to a secured WebCenter site (for example one that uses HTTPS://), then you have to export its security certificate and import it on the Automation Engine server. If this is not done, publishing from Automation Engine to WebCenter will result in an error. Learn more on how to do this in the chapter **Install SSL Certificates on the Workflow Production Server** of the [WebCenter documentation](#).



**Tip:** After configuring a new WebCenter site, it is recommended to close your Pilot and start it again in order to see the updated list of WebCenter sites in your tickets.

## Workflows

- **Token Limit:** (default value = 10000) This setting enables to automatically stop workflows that cause noticeable problems with the workflow server because they use an excessive amount of workflow tokens. Such problematic workflows need to be analyzed and adapted.

Learn about what tokens are in [Understanding Tokens \(Grouping of Output Files\)](#) on page 796.

Learn more in [Avoid excessive amounts of Tokens](#) on page 777.

## 5.10.15. Connection Doctor

The [Connection Doctor](#) allows you to troubleshoot the Pilot. This is documented in the dedicated chapter [Troubleshooting](#) on page 2060.

## 6. Tasks and Workflow Controls

---

This chapter lists and describes all available Tasks and Workflow Controls. Some of these tasks and tools are optional.

Some of the pages are just a placeholder and refer to another page where the task is documented as part of a dedicated chapter related to that technology.

Task that have the suffix "**(Classic)**" in their name are using classic graphic engines (dating pre-ArtPro+). Learn more in [Which AE task Uses which Technology?](#) on page 66.

At the end of this complete list, you can learn more about the [Outdated and Soon Outdated Tasks in this Version](#) on page 531.

### 6.1. Add Dynamic Marks

---

#### Concept

Use this task to add a set of **Dynamic Marks** to the input PDF file.

Such a set of marks can be created in ArtPro+ or in Adobe Illustrator by using the [Dynamic Marks plugin](#).

#### Input - Output Files

- **Input files:**

This task uses the [NDL graphics kernel](#) from ArtPro+. So it supports all types of PDF files.



**Note:** Just like in ArtPro+, normalized PDF files will first be made self-contained, then the marks are added and then the file is output again as Normalized PDF.

- **Output files:**

The output file is the same type as the input file: PDF or normalized PDF. The output file will contain all the information from the input file (for example object based screening in a PDF+ file).



**Note:** In case your output is a native PDF file but your workflow requires a normalized PDF, then use the task **Normalize PostScript / PDF / Illustrator file** as the next workflow step. However, make sure that, in the **Inks** tab, you select the option **'Use rulings, angles and dot gain compensation from file'** to preserve the screening parameters.

- Handling of **Page Boxes:**

The output file inherits, for each of it's pages, the PDF page boxes of the corresponding page of the input file.

- In case the pages have a crop box, the crop box on each page will get extended so that it includes all the Dynamic Mark objects that were added to the page.
- In case the pages have a media box, the media box on each page will get extended so that it includes all the Dynamic Mark objects that were added to the page.
- Page boxes are extended only after the Dynamic Marks are evaluated/calculated. Therefore, for example, a Text Mark displaying the size of the media box will show the original size (before media box was extended).

**General Behavior**

- A task is started for every input file.



**Attention:** When you don't specify a different output file name or folder, this task will overwrite the input file!

- When the Dynamic Mark set(s) that you add adds extra separations (for example a Dynamic Mark with static colors), the XMP ink set of a normalized PDF will be properly updated.

**Task Settings**

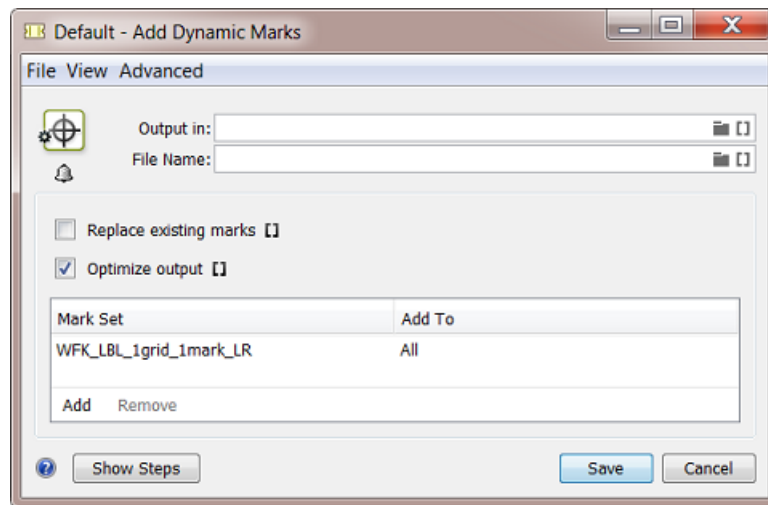

- **Replace existing marks:**

Select this to remove all Dynamic Marks already present from the input file while adding the new set of Dynamic Marks.



**Note:** When selected, this will also remove marks that are unknown or from a too old or too new version.



**Note:** When selected, this will not replace any SmartMarks, only Dynamic Marks.

When you want to set the value via a SmartName, this option will be enabled when the resolved value starts with a 'x' or 'y' or '1'. Any other starting character will resolve to disabling this option.

- **Optimize output:**

This option can be useful when PDF+ marks need to be added to many pages. The optimization is mainly in the speed of this task itself. The size of the output file may also be a bit smaller. And there will also not be a significant change in RIP'ing time.



**Note:** In case of VDP jobs (which also have many pages), it is more common to add marks during the Step & Repeat part of the workflow.

- When **not selected**, the task adds and evaluates the added marks on each page separately. The marks also stay live objects: when you open the output in ArtPro+, you see the marks' properties and you can modify them.





**Note:** Only ArtPro+ PDF+ Marks stay live objects. DMK mark sets made in DeskPack will here always be expanded (become dead objects).



**Note:** This option was formerly named "Calculate for each page (more accurate)".

- When **selected**, the task evaluates the marks only once and then copies them to all pages. In the output file, all marks (all types) are then stored as dead objects.

Be aware of this possible effect: When a mark places all ink names, then it will on all pages show all the inks from the complete document, even when some pages may use only a subset of those inks.



**Note:** This option was formerly named "Calculate once and copy (faster)".



**Note:** Selecting his option will make the task fail when the input file contains a Plate ID object (mark). This type of object may not be expanded before it was applied to a LENX file. Learn more in [Working with Plate ID](#) on page 1554.

- **Mark Set:** In this table, you define which dynamic mark set you **Add To** which pages. Learn more about adding mark sets below.

### Adding Mark Sets

- Click **Add** and specify the **Mark Set**. Select it from the list, or type its name or use SmartNames. The list will show
  - DMK files, normalized marks from DeskPack
  - PDF files with PDF+ marks, created in ArtPro+.



**Note:** Adding a combination of these mark types is supported but not recommended.

In '**Add To**': Specify on what page(s) the mark set should be applied: **All, Even, Odd, First** or **Last page**.

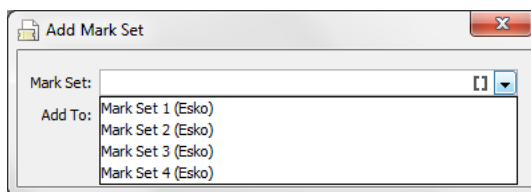

- Use the buttons **Remove** and **Edit** to further manage this table.

## 6.2. Add Ink Eaters (Classic)

**Ink Eaters** help to achieve a constant ink consumption over the width of the plate. This makes it easier for press operators to set the **ink keys**, and results in a faster setup time for the press.

Ink Eaters are typically added to non-printed areas outside the printing job. These areas can be left-overs that will be cut off or the white spaces next to or even in between the one-ups.

Ink Eaters help to avoid excess ink build-up by stabilizing "peaks" and "lows" in the ink key **histogram**. This prevents spilling of excess ink onto the printed zones of the actual printing job. You can flatten the ink key histogram by filling non-printed zones with a gradient. A gradient helps to avoid hard edges in the compensation object. You can specify a minimum ink density and a minimum ink key value. You can request warnings when the maximum Total Area Coverage (TAC) is too high. These areas are then compensated (filled with ink) depending on the strategy settings.



The task settings allow you to determine where the ink eater areas should be and with what they should be filled:

**Ink Eaters tab**

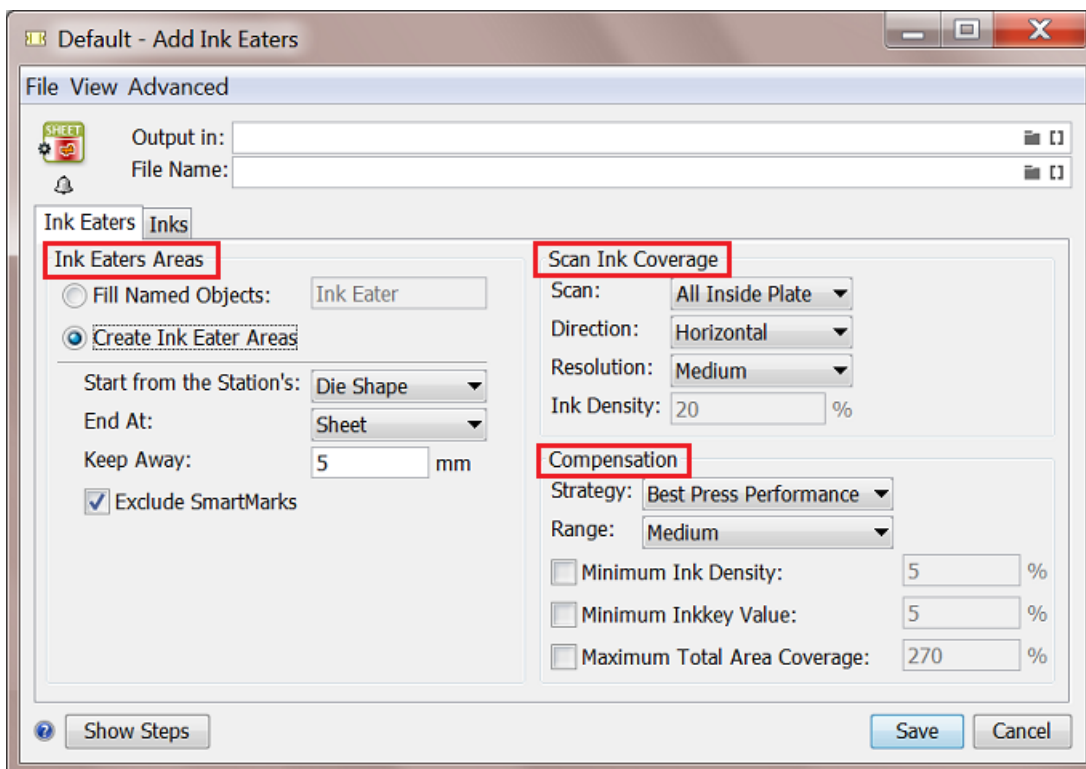

- **Ink Eaters Areas**

- **Fill Named Objects:** Type in the name of the **Named Object** as you defined it in Esko Plato for example.
- **Create Ink Eater Areas:** Specify the start and end of the areas:
  - **Start from Station's**
    - **Die Shape:** Select this to start from a die shape (for example pre-defined in Plato).
    - **Trim Box** or **Media Box:** Select this to start from the Trim or Media Box of the one-up on the plate. Media Box is larger and it contains the Trim Box.
    - **Die Annotation:** Select this to start from the object that was marked as a die (for example in Plato).
  - **End at:** Specify what should be used as the end of the area.
  - **Keep Away field:** Fill in a distance to set an offset for the Ink Eater object in relation to the die shape or Trim Box.
  - Select **Exclude SmartMarks** if you want to exclude SmartMarks from the Ink Eater object.

- **Scan Ink Coverage:**

When you selected a contour object or a group of objects for ink coverage, select one of these options:

- **Scan:** Specify what area needs to be scanned:

- **All Inside Sheet** (Sheet View): To scan within the sheet and exclude objects outside the sheet.
- **All Inside Plate** (Sheet View): To scan all objects on the sheet and plate. Objects that extend the plate area or are outside the plate are not included.
- **Direction**: This is the scanning direction. **Horizontal** means that the ink zones are vertical on the plate and the ink histogram is on the horizontal base of the document. The direction of the compensation gradient in the ink eater area is horizontal.
- **Resolution**: This defines the number of intermediate steps of the gradient to be used as compensation. Use **Very Low** for 5 steps, **Low** for 15 steps, **Medium** for 30 steps, **High** for 45 steps and **Very High** for 60 steps.



**Note:**

You can achieve **global compensation** by defining a low resolution value (for example 5 gradient steps). This gives a very smooth compensation gradient along the length of the press. The ink histogram zones are then very wide.

You can achieve **very local compensation** by defining a high resolution value (for example 60 gradient steps). This results in a gradient with more banding.

- **Ink Density**
- **Compensation**
  - **Strategy and Range**: This defines how the Ink Eater areas should be filled.
    - **Economic**: This minimizes the use of ink.
    - **Intermediate**: This optimizes ink use to result in a medium performance in print..
    - **Best performance**: This maximizes the use of ink to give the best print performance.
  - **Minimum Ink Density**: Select this option to define a minimum density.
  - **Minimum Ink key Value**: Select this option to define a minimum ink key value for the ink eater area. The ink density of the gradient will be adjusted to make sure the ink key value is higher than this setting.
  - **Maximum Total Area Coverage**: Select this option to define a maximum total area coverage (for example 270%). You will then get warnings when in those areas of the histogram where the total ink coverage exceeds this limit.

**Inks tab**

- Select **Non-process**, **Opaque** and/or **Varnish** inks if you want to **Exclude** them from being used in the ink eaters. .
- Select **Keep similar inks in their original separations** to keep the original separations in the output file.

### 6.3. Add Marks to Imposition

---

Learn more in the dedicated document on "Commercial Print (Imposition) workflows in Automation Engine". Find it next to the "Complete Manual" of version AE **18.1** on <https://www.esko.com/en/Support/Product?id=Automation%20Engine&ver=18.1>.

### 6.4. Add Margins to LEN File

---

This task is documented in the chapter [Flexo CTP Device Workflow](#) on page 1482. Find a direct link [here](#).

### 6.5. Add Parameters for Nesting (Classic)

---

This task is documented in the chapter [Sign & Display Workflow](#) on page 953. Find a direct link [here](#).

### 6.6. Add SmartMarks (Classic)

---

#### Add SmartMarks

This task applies a set of SmartMarks to a PDF file. A SmartMark set is a group of marks that can be created in PackEdge, Plato or i-cut Layout. Learn more about creating them in the user manuals of these editors.

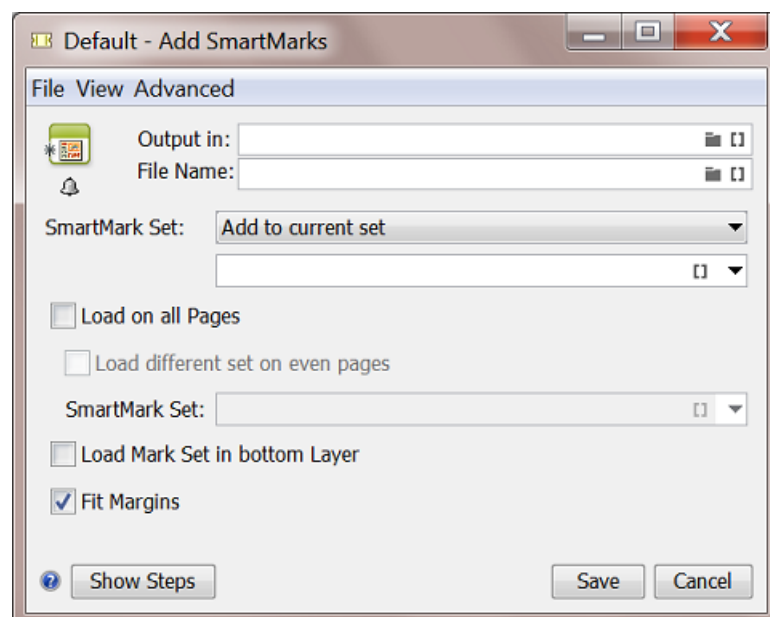

Your input file may already have SmartMarks. You first need to decide what to do with those:

- **Add to current set:** This merges the new SmartMark set with any already present SmartMark sets.
- **Replace current set:** This replaces any already present SmartMark sets.



**Note:**

- Since only a normalized PDF file can contain SmartMarks, **Replace current set** is not relevant for native PDF files.
- When applying a SmartMark set on a native PDF file, the task output file will also be a native PDF. Any applied SmartMark set will be converted into normal PDF objects. Learn more about native and Normalized PDFs in [File Types and How they are Recognized](#) on page 37.

**Load on all Pages:** This loads the selected SmartMark set on all pages of a multi page input file.

**Load different set on even pages:** This loads a different SmartMark set on the even pages of a multi-page input file. For example on the backside of a layout. When selected, define the name of the extra set.

**Load Mark Set in bottom Layer:** This allows you to choose if the marks should be applied on top of the graphics or if the graphics should be on top of the marks.

**Fit Margins:** Depending on the setup of your SmartMark set, marks can be (partially) positioned outside the PDF's Media Box. Select this option to extend the Media Box to all visible content outside the Trim Box.

## 6.7. Add to Pages View (Classic)

---

Learn more in the dedicated document on "Commercial Print (Imposition) workflows in Automation Engine". Find it next to the "Complete Manual" of version AE **18.1** on <https://www.esko.com/en/Support/Product?id=Automation%20Engine&ver=18.1>.

## 6.8. Add To Products

---

This task is documented in the chapter [Products](#) on page 594. Find a direct link [here](#).

## 6.9. Adjust PDF Screening (Classic)

---

This task serves to apply rule-based modifications of screening parameters. One rule could be enough to accommodate various specific requirements, but if needed you can add an elaborate set of rules (see an example below).

You can preview the **Separation Details** when a file is selected. This will display the results for the specified set of rules in the current file.

Some example applications:

- You can also criteria like **Ink Book**, **Printing Method** or **Ink Type**. For example: when the printing method is **flexo**, set the **Dot shape** to "F".

- Or use SmartNames. For example: if the ink name is "Cyan", "Magenta", "Yellow" or "Black", set **Dot shape** to [mydotshape] .
- A more elaborate example when using **Object Based Screening**: when the name is "Cyan" and angle is between "0" and "45", then set the angle to "30" and **Dot shape** to "R".



**Note:** In native PDF, the screening parameter '**DotShape**' does not exist. Instead there is a '**SpotFunction Name**', which can have a limited number of values like **SimpleDot**, **Ellipse**, or **Square** which are mapped to the Esko dot shapes "C", "E", "S" respectively. Other **SpotFunctionName** values are mapped to "C".

When reading Native PDF files, the task **Normalize PostScript / PDF / Illustrator File** does not take account of the DotShapes (SpotFunction Name) values. You need to adjust the PDF Screening parameters during or after normalization.

1. Click **Add** to define a rule.

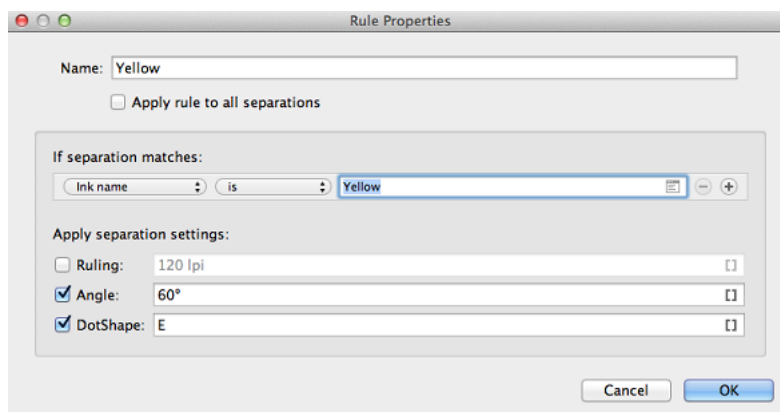

2. Enter a **Name** for the rule. For example the name of the ink that you here adjust.
3. Select '**Apply rule to all separations**' when this is what you want.
4. Define a condition under '**If separation matches**'. You can choose from **Ink name**, **Ink book**, **Ink type**, **Printing method**, **Ruling**, **Angle** and **Dot shape**. Set the condition and enter a related text in the field. Click to pick a separation name from those found in the input file. If needed, add more criteria by clicking on '+'.



**Note:** Setting up these rules is very similar to creating filters in Views. Learn more in [Using Filters and Creating Smart Views](#) on page 140.

5. Define what you want to adjust in '**Apply separation settings**'. You can specify **Ruling**, **Angle** and/or **Dot shape**.
6. Click **OK**.
7. Repeat steps 1-6 to add more rules.

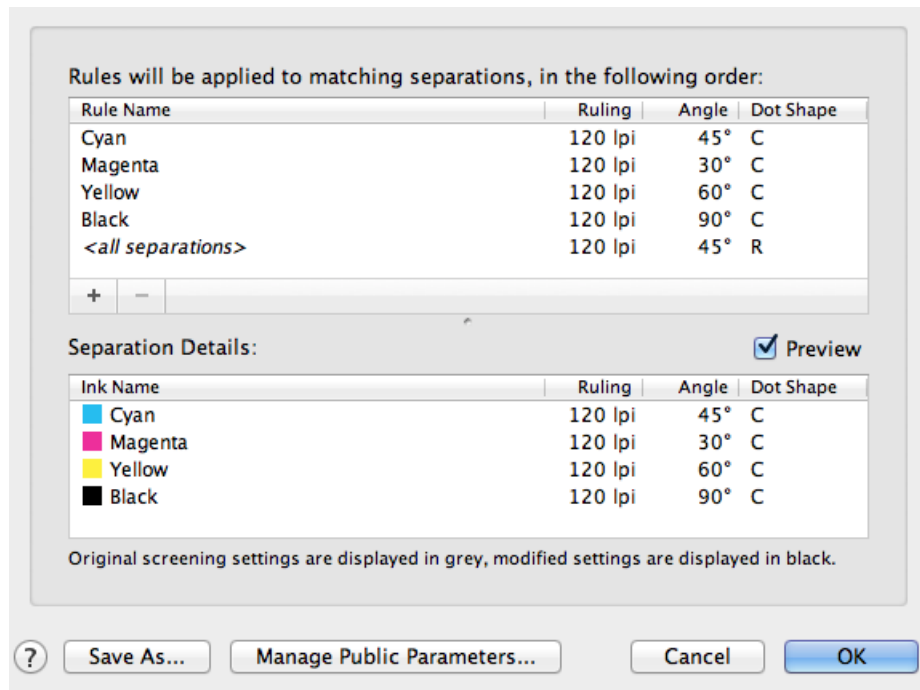

Rules are applied from top to bottom. When a separation was already handled by a rule, it will not be handled again by a lower set rule. In above example screenshot, the rule "<all separations>" will only be applied to all *other* separations that were not handled by any rule set above.

When an input file was selected, you can click **Preview** to see what the above rules will result in.

8. Click **OK** to save the ticket.

## 6.10. Adjust PDF Screening

### Concept

This task serves to apply rule-based modifications of screening parameters in PDF(+) files. One rule could be enough to accommodate various specific requirements, but if needed you can add an elaborate set of rules.

This task does not support Normalized PDF as input files. Those can be handled by the [classic version of this task](#).

### Task Settings

When no different output name or folder is specified, the task will overwrite the input file.

- **Screening Rules.** Use this pane to **Add** or **Remove** rules.

As usual in an Automation Engine ticket, when multiple rules are defined, they are executed top to bottom.

- Click **Add** to open the dialog to define a rule.





**Note:** String matches are not case sensitive. For example for ink specifications you can search with PANTONE or Pantone or for a dot type with R or r.



**Important:** About **linked placed art**: This task can also adjust screening parameters from linked art (for example Step & Repeat PDF+ files). When this task changes screening parameters from linked art then placed art becomes unlinked from the original document.

- **Apply screening rules to unscreened objects:**

When selected, the task will also apply the defined screen set to objects that have no screen set applied yet.

The objects that then get a new Screen Set 1, Screen Set 2, ... are:

- Unscreened top level objects in the file (= those that can be edited in a PDF editor)
- Unscreened objects in embedded art (typically content of Step & Repeat grids)
- Unscreened objects in linked placed art or Step & Repeat grids, after which the linked placed art will be unlinked.

## 6.11. Apply ArtPro Action List (Classic)

This task is documented in the dedicated chapter [ArtPro automation - ArtPro Action Lists](#) on page 914. Find a direct link [here](#).

## 6.12. Apply PDF Action List

### Concept

This task executes a PDF Action List on PDF files. The PDF Action Lists (\*.pal files) are created in [Esco ArtPro+](#). This allows to automate a linear series of functions that you would otherwise execute within ArtPro+.

The actions are done on a selection of the objects in the PDF. This could be all objects (default) or a specific subset. When the action is done, the selection contains the objects that were modified by the action.

Learn all about creating PDF Action List files in [the documentation of ArtPro+](#).



**Tip:** Always test the action list in ArtPro+ first before running it as a task on the server.

### Task Settings

- **Action List:** Click  and select an Action List. Or define one via a SmartName. In the UI of ArtPro+, these are called **Server Action Lists**.



**Note:** The server action list files (\*.pal) need to be in the folder \\<Name-of-AE-Server>\bg\_data\_custom\_v010\dat\PDF Action Lists.

- **Options:** When the Action List contains 'Action List Parameters', they will show up here as options and you can change their value. Such parameters are added in ArtPro+.

- **Description:** This shows the user and the software version that created this .pal file. A later version of ArtPro+ will allow you to add other info.
- **Apply on Pages:** Leave this empty to have the action list applied on all pages.

**Extra Output Pin**

When used in a workflow, this task provides an extra output pin named 'Extra'. This is where extra output files will appear.

Currently, only the action **Extract embedded images** places the extracted images on that separate output pin. This allows to collect these image files for any further processing.

**About Types and Units**

In the **Options** panel, when you type in values for the Action List Parameters, it is important to know which type that parameter is and which unit will be used.

Each Action List Parameter has a type. This type is defined by ArtPro+, based on where the parameter is used. There are several parameter types:

- **Text:** Can for example be used to define the name of a layer or separation. Any UTF-8 string can be used in this type.
- **Number Without Unit:** Can for example be used to define the miter limit of a stroke.
- **Number With Unit:** Can be used to define distance, size, resolution, angle or percentage.

Different parameter types use different units:

**Table: Defaults Units in Action List Parameters**

<b>Length</b>	Millimeters
<b>Stroke</b>	Millimeters (represents stroke width)
<b>Font</b>	Points (represents font size)
<b>Area</b>	Square Millimeters
<b>Resolution</b>	Pixels per Inch
<b>Percent</b>	Float number where 100.0 means 100 %
<b>Count</b>	Whole number without a unit
<b>Number</b>	Float number without a unit
<b>Angle</b>	Degrees CW
<b>String</b>	A string (no units)

When you want to use a different unit, type it in as well. Press 'Tab' to see its conversion to the default unit immediately.

When using a SmartName, it has to resolve in:

- either in a value without units, then the default will be taken.
- or in a value that also specifies the units, for example: "4.5 in".

## 6.13. Apply Creep

Learn more in the dedicated document on "Commercial Print (Imposition) workflows in Automation Engine". Find it next to the "Complete Manual" of version AE **18.1** on <https://www.esko.com/en/Support/Product?id=Automation%20Engine&ver=18.1>.

## 6.14. Apply PantoneLIVE Condition (Classic)

### Concept



**Important:** This task requires you to be familiar with **PantoneLIVE**. PantoneLIVE ink books are ink books that take into account on what substrate an ink will be printed on. These books are stored in the cloud. Learn more in the [user guide of the Color Pilot](#).

This task replaces all Pantone inks in the file with inks from the selected PantoneLIVE **Dependent Standard Condition** (that you already downloaded). Only the ink name and ink book changes. Other ink settings (ruling, angle, dot shape, ink type and printing method) are not changed.



**Note:** This kind of ink mapping is what users of PantoneLIVE do interactively in Esko PackEdge. This task may be a more productive way.

See this figure showing several inks of the **identity 120** :

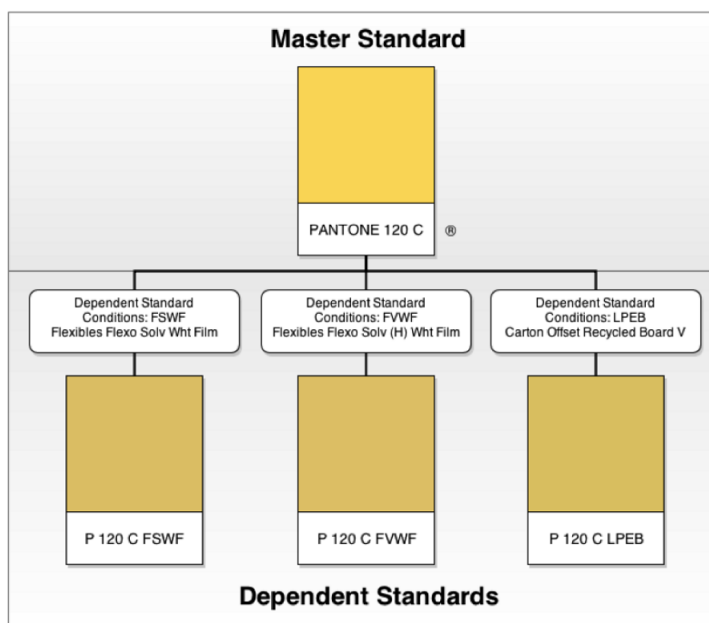

### Possible Mappings

This task can change

- any Pantone (or PantoneLIVE **Master**) ink to the corresponding ink in the selected target '**Dependent Standard**'.
- any PantoneLIVE Dependent Standard ink to the corresponding ink in the (other) target dependent standard.



**Note:** If the input file contains a PantoneLIVE dependent ink and a Pantone (or PantoneLIVE master) ink with the same identity (for example P307C FSGB and PANTONE 307 C), and if the dependent standard of the ink in the file corresponds with the target dependent standard, then both inks will be merged (in our example they are merged to P307C FSGB).



**Attention:** This task does not change:

- any non Pantone inks found in the input file
- any CMYK process inks found in the input file.

## 6.15. Apply Plate ID to LENX file

---

This task resolves the metadata describing the Plate ID into the LENX file's pixels. It uses a pattern that is fit for the selected type of flexo plate.

This task is described in the chapter [Flexo CTP Device Workflow](#) on page 1482.

Find a direct link [here](#).

## 6.16. Archive Job

---

This task is documented in the [separate chapter about Jobs](#). Find a direct link [here](#).

## 6.17. Assign PDF Pages to RunList

---

Learn more in the dedicated document on "Commercial Print (Imposition) workflows in Automation Engine". Find it next to the "Complete Manual" of version AE **18.1** on <https://www.esko.com/en/Support/Product?id=Automation%20Engine&ver=18.1>.

## 6.18. Change Imposition Layout

---

Learn more in the dedicated document on "Commercial Print (Imposition) workflows in Automation Engine". Find it next to the "Complete Manual" of version AE **18.1** on <https://www.esko.com/en/Support/Product?id=Automation%20Engine&ver=18.1>.

## 6.19. Change Location of Inactive Jobs

---

This task relates to near-line storage for AE SaaS customers.

Learn more in the chapter [AE SaaS: When your AE is in a Data Center](#) on page 1633, in the section about [Inactive Jobs](#), on the page [Task 'Change Location of Inactive Jobs'](#) on page 1658.

## 6.20. Change Location of Jobs

---

This task enables to set (or update) this Location attribute for all Jobs that match the filter defined in the task ticket.

Learn more in the chapter [Jobs](#), in the page [Task 'Change Location of Jobs'](#) on page 593.

## 6.21. Change Location of Products on Esko Cloud

---

This task relates to near-line storage for AE SaaS customers.

Learn more in the chapter [AE SaaS: When your AE is in a Data Center](#) on page 1633, in the section about [Storing Products on Esko Cloud](#) on page 1658, on the page [Task 'Change Location of Products on Esko Cloud'](#) on page 1665.

## 6.22. Change Location of Products

---

This task enables to set (or update) this Location attribute for all Products that match the filter defined in the task ticket.

Learn more in the chapter [Products](#), on the page [Task 'Change Location of Products'](#) on page 633.

## 6.23. Check Dynamic VDP Database

---

### Concept

This task validates a VDP database before running the **Expand Dynamic VDP Data** task. Although the same checks are done as in the **Expand Dynamic VDP** task, this **Check Dynamic VDP Database** task faster because it does not generate any output.

This task analyzes all entries from the database using rules stored in Variable Data Template (VDT file).



**Note:** When used in a workflow and the check succeeds, the task will produce a database CSV file which can be used as input for the next workflow step. When the check fails, the task delivers a report file listing the detected issues.

This task requires

- a CSV file as input
- a VDT file as mandatory parameter.

**Task Settings**

- **CSV File Encoding:** Specify the wanted character encoding. The default encoding is **UTF-8**. This is also the recommended encoding.
- **Field Separator:** Let the task **Detect automatically** or choose **, (Comma)**, **;(Semicolon)**, **Space** or **Tab**.
- **Empty lines:** Choose what needs to happen with empty lines in the input CSV file. Only lines ending with CR, LF or CR LF can be detected as an empty line (it is possible to mix different line endings in a single file). All empty lines at the end of the file are skipped.
- **Field Names:** Field names map data chunks from the database entry to its corresponding VDP template items. Choose from:
  - **From CSV File:** When selected, the task will extract **Field Names** from the first record of the CSV file by default.



**Attention: Field Names** can only contain the following characters: lower- or upper-case ASCII letters ("a-z, A-Z"), digits ("0-9") or underscore ("\_").

- **From Header File:** When selected, define a **Header File** that contains the **Field Names**. Such a file
  - should contain a single line specifying the **Field Names**
  - should have a **Field Name** corresponding to each column in the CSV file.
  - and the CSV file must use the same delimiter and encoding.
- **Template:** browse to the Variable Data Template file that contains the rules to check the database validity. Such a template is created and exported using the **Dynamic VDP** DeskPack Plug-in for Adobe Illustrator.

## 6.24. Check Job Parameters (Classic)

---

This task is documented in the chapter dedicated to [Jobs](#) on page 538. Find a direct link [here](#).

## 6.25. Check Job and Product Parameters

---

This task is documented in the chapter dedicated to [Jobs](#) on page 538. Find a direct link [here](#).

## 6.26. Check Print Rules (PRC)(Classic)

---

This task is documented in the chapter [Quality Control tools](#). See [Check Print Rules \(PRC\)\(Classic\)](#) on page 1175.

## 6.27. Check Product Parameters (Classic)

---

This task is documented in the chapter [Products](#) on page 594. Find a direct link [here](#).

## 6.28. Check Technical Inks (Classic)

---

This task checks if the input file (Normalized PDF, PDF or Plato File) or any of its external references contains objects that have a technical ink set in knockout.

When it finds such objects, the task allows you to decide if it then should fail or only end with a warning.

Learn more in the chapter [How to?](#), on the page [How to Work with Technical Inks \(Normalized PDF\)](#) on page 1955.

## 6.29. Compare PDF (Classic)

---

This task is documented in the chapter [Quality Control tools](#). See [Compare PDF \(Classic\)](#) on page 1176.

## 6.30. Contourize & Clean (Classic)

---

This old technology is still supported but no longer commercially available.

Please find its documentation in the [manual of Automation Engine 14.1 or older](#) (as part of the Reference Guide).

## 6.31. Convert CMYK Colors (Classic)

---

This old technology is still supported but no longer commercially available.

Please find its documentation in the [manual of Automation Engine 14.1 or older](#) (as part of the Reference Guide).

## 6.32. Convert Colors for Digital Printing (Classic)

---

This task is documented in the chapter [Digital Printing Workflow](#) on page 1589. Find a direct link [here](#).

## 6.33. Convert Colors with Equinox

### Concept

You can use this task to convert PDF files' colors using [Equinox](#).

Equinox is Esko's award winning **expanded gamut printing** solution. Expanded gamut printing is using a standardized set of 5, 6 or 7 inks for printing, instead of CMYK plus different spot colors for each print job.

Equinox functionality is available in Automation Engine, [ArtPro+](#), [Color Engine Pilot](#), as a plug-in for Adobe Photoshop and in Esko legacy editors ArtPro and PackEdge.

Learn more in the [Equinox user manual](#).

### File Support

- The task supports PDF, PDF+ files and PDF+ Variable Template files.
- In PDF+ Variable Template files only static objects are converted. VDT templates from DeskPack are not supported.
- This task does not support Normalized PDF files. For those, use the [classic version of this task](#).

### Task Settings

The screenshot shows the Equinox task settings dialog. At the top left is a 'COLOR' icon with a gear and a bell. Below it are two input fields: 'Output in:' and 'File Name:', each with a folder icon and a right-pointing arrow. The main settings area contains three dropdown menus: 'Color Strategy' (selected: BRBE\_Equinox\_CMYKOGV), 'Undefined Spot Colors' (selected: Ignore (keep in output)), and 'Convert' (selected: Images and Linework). Below these is a checkbox labeled 'Flatten objects before conversion' with a right-pointing arrow.

- **Color Strategy:** Select the one you want to use for the conversion. This must be an **Equinox Color Strategy** that you have created in the Color Pilot.

Typically, your color strategy doesn't only contain general color conversion settings, but also specific color builds, either for the spot colors that you use the most, or for a whole Pantone book.

These color builds determine the exact percentages of the available output inks that will be used to print the corresponding spot colors. These have often been adjusted by your color expert to give you the spot color simulation you want.

- **Undefined Spot Colors:** Choose what to do when the file contains a spot color for which your color strategy has no color build.
  - Select **Ignore (keep in output)** if you want to leave the spot color untouched in the output file. Do this for example if you are using certain spot colors as extra output inks (typically white or metallic inks).



- Select **Convert** to convert that spot color to the color strategy's output profile using the strategy's general color conversion settings. These include the black generation for spot colors, rules about ink combinations, etc. Learn more about color strategy settings in the [Color Pilot user guide](#).
- Select **Fail (generate error)** if you don't want to convert the file at all but instead have the task end in error. Select this if you always make a color build for each spot color, so in this situation you want to stop the workflow and investigate why this is not the case. You may want to either replace the spot color in your file, or add a color build for that spot color in the color strategy.
- **Convert:** Select what type of data to convert: linework data, images or both.
- **Flatten objects before conversion:**
  - When **selected**, the document will first be completely flattened and then color converted. The result will be a file with non overlapping regions colored with the output ink set. The rendered result in the output file will be similar to the input PDF.
  - When **not selected**, objects will be color converted and keep their overprint, transparencies and opacity masks. The result file will have the same object structure as the input PDF but objects will be colored with the output ink set. The render result may differ drastically from the original PDF.

An example. This file contains three objects:

- the background (sky),
- the lighthouse, which is knocking out on the background object,
- the wave, which is overprinting on both the lighthouse object and the background object.

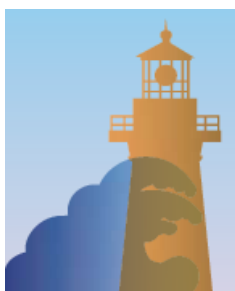

Flattening your file replaces the parts of objects that were overprinting or transparent by other objects. Those new objects have the color that was resulting from the overprint/transparency, but are not overprinting or transparent.





**Attention:** We recommend that you:

- flatten files with overprints, transparencies or vignettes,
- don't flatten files that you still need to trap or edit afterwards.

If you need to both flatten and trap your file, make sure to do your trapping first, and place the **Convert Colors with Equinox** task towards the end of your workflow, as close to the output device as possible.

## 6.34. Convert Colors with Equinox (Classic)

You can use this task to convert PDF files' colors using [Equinox](#).

Equinox is Esko's award winning **expanded gamut printing** solution. Expanded gamut printing is using a standardized set of 5, 6 or 7 inks for printing, instead of CMYK plus different spot colors for each print job.

Equinox functionality is available in Automation Engine, [ArtPro](#), [PackEdge](#), the [Color Pilot](#) and as a plug-in for Adobe Photoshop.

Learn more in the [Equinox user manual](#).

### Use Cases

Use this task to convert your file's colors to prepare for expanded gamut printing, especially in these cases:

- You don't have ArtPro or PackEdge and you work with regular (native) PDF files.

With this task, you don't need to convert your file to an ArtPro file or a Normalized PDF file before conversion, but you can get the same results as if you did.

- You do have ArtPro or PackEdge, but you want to automate the conversion.

You can, for example:

1. Set up an Equinox color strategy in the Color Pilot. Learn how in the [Color Pilot](#) user guide.
2. Use that color strategy to experiment with Equinox conversion in ArtPro or PackEdge, and make small adjustments to the conversion until it is exactly the way you want it.
3. Then use the adjusted color strategy in this **Convert Colors with Equinox** task to automate the conversion of all your file's variants or "SKUs" (Stock Keeping Units), for example for different languages, sizes, flavors...

This task takes both PDF and Normalized PDF files as input. When working with regular PDFs, it will automatically normalize them using the **Normalize ticket** that is selected in the **Configure** tool's [Processing Preferences](#).

This task keeps your file's metadata intact (for example CAD information).



**Tip:** We recommend you place this task towards the end of your workflow, as close to the output device as possible.

### Parameters

1. Select the **Color Strategy** you want to use for the conversion. This must be an **Equinox Color Strategy** that you have created in the Color Pilot.

Typically, your color strategy doesn't only contain general color conversion settings, but also specific color builds, for either the spot colors you use the most, or for a whole Pantone book.

These color builds determine the exact percentages of the available output inks that will be used to print the corresponding spot colors. These have often been adjusted by your color expert to give you the spot color simulation you want.

2. In **Undefined Spot Colors**, choose what to do when the file contains a spot color for which your color strategy has no color build.

- Select **Do not convert (keep in output)** if you want to leave the spot color untouched in the output file. Do this for example if you are using certain spot colors as extra output inks (typically white or metallic inks).

In this case, the task will end in a warning.



**Tip:** Consider setting up your workflow so that:

- the output file gets sent to the next task automatically (if you are sure that those spot colors are extra output inks),
- further processing of the output file is paused, so that you can check whether those spot colors are actually extra output inks.

- Select **Convert** to convert that spot color to the color strategy's output profile using the strategy's general color conversion settings (see the [Color Pilot](#) user guide for more information about color strategy settings).
- Select **Generate error** if you don't want to convert the file at all, and instead have the task end in error.

Do this if you always make a color build for each spot color, so in this situation you want to stop the workflow and investigate why this is not the case. You may want to either replace the spot color in your file, or add a color build for that spot color in the color strategy.

3. Select **Hide Technical Inks** if you want to keep technical inks out of the conversion.

4. Select **Flatten document** if you are experiencing unexpected color results when converting files containing overprints, transparencies or vignettes.

Flattening your file resolves its overprints and transparencies, and converts its vignettes to images.

In the example below, the original file contains three objects:

- the background (sky),
- the lighthouse, which is knocking out on the background object,
- the wave, which is overprinting on both the lighthouse object and the background object.

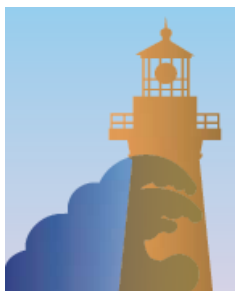

Flattening your file replaces the parts of objects that were overprinting or transparent by other objects. Those new objects have the color that was resulting from the overprint/transparency, but are not overprinting or transparent.



**Attention:** We recommend that you:

- flatten files with overprints, transparencies or vignettes,
- don't flatten files that you still need to trap or edit afterwards.

If you need to both flatten and trap your file, make sure to do your trapping first, and place the **Convert Colors with Equinox** task towards the end of your workflow, as close to the output device as possible.

5. For CMYK objects, you can choose to **Convert** either:

- **Images and Linework,**
- **Linework only.**
- **Images only.**



**Attention:**

- If your file contains a **Device N** image (an image that contains one or more spot colors), its spot color(s) will be converted even if you select **Convert Linework only**.
- Flattening your file converts vignettes into images. This means that:
  - If you selected **Flatten document**, vignettes will be color converted when you chose to **Convert Images and Linework** or **Images only**.
  - If you didn't, they will be converted when you chose to **Convert Images and Linework** or **Linework only**.

## 6.35. Convert IMP File to Normalized PDF File (Classic)

Learn more in the dedicated document on "Commercial Print (Imposition) workflows in Automation Engine". Find it next to the "Complete Manual" of version AE **18.1** on <https://www.esko.com/en/Support/Product?id=Automation%20Engine&ver=18.1>.

## 6.36. Convert JSON to XML

---

This task is documented in the chapter [Integrating with External Systems](#). Find a direct link [here](#).

## 6.37. Convert Selection

---

Learn more in the dedicated document on "Commercial Print (Imposition) workflows in Automation Engine". Find it next to the "Complete Manual" of version AE **18.1** on <https://www.esko.com/en/Support/Product?id=Automation%20Engine&ver=18.1>.

## 6.38. Convert to ARD/MFG

---

### Concept

This task serves to convert a CF2 one-up design to an ARD file or a CF2 layout file to an MFG file.

It is mainly used in system integrations where the user of the MIS can trigger this task. This kind of CAD automation for example enables

- the CSR (MIS user) to make a layout based on a one-up CF2 received from the customer.
- to convert an incoming layout CF2 to an MFG to be used in ArtiosCAD for tool-making.

### Task Settings

- **Use custom tuning file:** A **Tuning File** helps in mapping lines and parameters between CAD files from two different platforms.
- **Board Code:** A board code is a group of settings that tells ArtiosCAD various things about the material used to manufacture the design. This can include information such as the thickness of the board, its weight, cost, inside loss, outside gain, scant, and allowance.
- **Board Description:** This is the description of the paper.
- **Grain Direction:** **Vertical** or **Horizontal**.
- **Print Side:** Define if the output is to be the **Inside** or **Outside** of a design.

## 6.39. Convert XML to JSON

---

This task is documented in the chapter [Integrating with External Systems](#). Find a direct link [here](#).

## 6.40. Copy Inactive Job to Jobs

---

This task relates to near-line storage for AE SaaS customers.

Learn more in the chapter [AE SaaS: When your AE is in a Data Center](#) on page 1633, in the section about [Inactive Jobs](#), on the page [Task 'Copy Inactive Job to Jobs'](#) on page 1654.

## 6.41. Copy or Move File

---

This task copies or moves the input file or **Marked** files to a new location.



**Restriction:** In an [AE SaaS setup](#), this task will, for security reasons, not be allowed to copy or move files that from outside a Container of this AE server. When the task's settings require this anyway, the task will fail. Also the task [Select File](#) follows this restriction.



**Note:** To **Mark** a file, insert the [Mark File](#) workflow control in your workflow. Learn more in [Mark File and Select Marked File](#) on page 828.

You can also launch this task on folders.

- Select the option if you want the task to **fail when the file to be copied or moved already exists in the output folder**.
- You can also choose to **not take over the Extension of the Input file in the Output file**.
- **Include View Data:** Choose if you also want to copy or move the View data. These are the [prepared view files for the Automation Engine Viewer](#). This also includes the XFDF annotation files that were created by any [Inspection task](#) that you launched on the files that you here copy or move.



**Note:** Before v21.07, the view data were always included.



**Tip:** When you are copying or moving a file to a hot folder, you most probably do not want to include this view data.

## 6.42. Create ArtiosCAD Layouts

---

### What?

This task provides optimized nesting solutions including output metadata that allows a business system to estimate the cost for these nesting solutions.

The task requires a design name, format class, MFG template, sheet size, nesting type, number of one-ups, sheet trim, gutter, margins etc. Output parameters includes metadata such as number of ups, blank size, waste percentage, rule length, etc.

It also accommodates the functionality of running a command script after layout is created. The task supports both Enterprise and Standard ArtiosCAD.

### More Info

This task is set up by an Esko Solution Architect. Learn about Esko Solution Services on <https://www.esko.com/support/solution-services>.

For more information, search for online articles on this topic in the [Esko Knowledge Base](#).

## 6.43. Create ArtiosCAD Report from XML

### What?

This task exports a 'report' of a design or layout to PDF, CF2, DCM and more file formats (configured in ArtiosCAD Server). The output 'report' file is written onto an external folder where it can be picked up to be interpreted by a business system or by a Kongsberg table.

This task takes an XML input file that describes a layout.



**Note:** This task can also print out this report.



**Note:** This technology was formerly known as 'Speclink' or exporting a 'shop card'.

### More info

This task is set up by an Esko Solution Architect. Learn about Esko Solution Services on <https://www.esko.com/support/solution-services>.

For more information, search for online articles on this topic in the [Esko Knowledge Base](#).

## 6.44. Create Design (DesignWizard) (Classic)

This task creates variants of a template design. The differences in the variants are described in an external file.



**Attention:** The template design needs to be made in Esko PackEdge.

This template design contains objects generated by SmartMarks (text, colors, objects, external files)

The DesignWizard task regenerates the SmartMarks using different data sets. These data sets can come as a field in a database (accessible from the Automation Engine server through ODBC), or they can come from fields in an XML file.

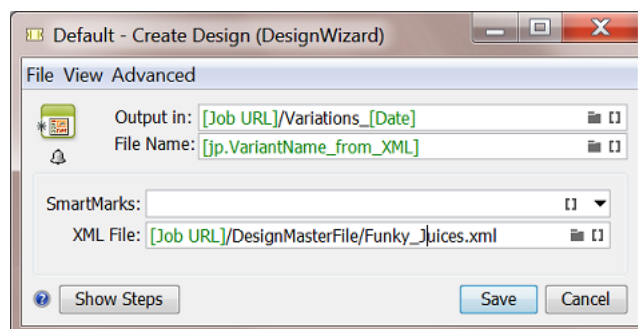

An example: These resulting juice designs vary in color, text and barcode. External references can also vary (images, logos).



The task used this XML file that describes their differences.

```
<?xml version="1.0" encoding="UTF-8"?>
- <dataroot xsi:noNamespaceSchemaLocation="Funky_juices.xsd"
  xmlns:xsi="http://www.w3.org/2000/10/XMLSchema-instance"
  xmlns:od="urn:schemas-microsoft-com:officedata">
  + <Funky_juices>
  + <Funky_juices>
  - <Funky_juices>
    <Design_Number>799884</Design_Number>
    <Product_Name>funky southern</Product_Name>
    <Litre_Size>2 LITRES</Litre_Size>
    <B_Number>B21-j134</B_Number>
  + <Ingredients>
  + <Packed_In>
    <Servings>10</Servings>
    <Serving_Size>200mL</Serving_Size>
    <Energy_Per_Serve>270kJ</Energy_Per_Serve>
    <Energy_Per_100>165kJ</Energy_Per_100>
    <Protein_Per_Serve>Less than 1g</Protein_Per_Serve>
    <Protein_Per_100>Less than 1g</Protein_Per_100>
    <Fat_Total_Per_Serve>Less than 1g</Fat_Total_Per_Serve>
    <Fat_Total_Per_100>Less than 1g</Fat_Total_Per_100>
    <Fat_Saturated_Per_Serve>0g</Fat_Saturated_Per_Serve>
    <Fat_Saturated_Per_100>0g</Fat_Saturated_Per_100>
    <Barcode>5010784005240</Barcode>
    <ink3>512</ink3>
    <ink4>356</ink4>
  </Funky_juices>
  + <Funky_juices>
</dataroot>
```

Learn more about how SmartNames can retrieve values from an XML file or directly from an external database in [Using SmartNames in a DesignWizard template](#) on page 274.

### 6.44.1. Using SmartNames in a DesignWizard template

The DesignWizard template picks up the variant values via SmartMarks that use SmartNames.

In the case of a live connection to a database, you create and use [Database Query SmartNames](#) on page 692.

In the case of XML files, the XML file is expected to have a similar format as when saving a database query into an XML file. This means the data can either be split over 1 file per instance (i.e. each XML file contains all the data for 1 variant) or there can be multiple sets in 1 XML file (see [this example](#)).

To get SmartNames out of such an XML file, you need to **Load** it into [Parameters tab of the Job Setup](#). Each new Job Parameter so automatically becomes available as a SmartName (inside this Job)



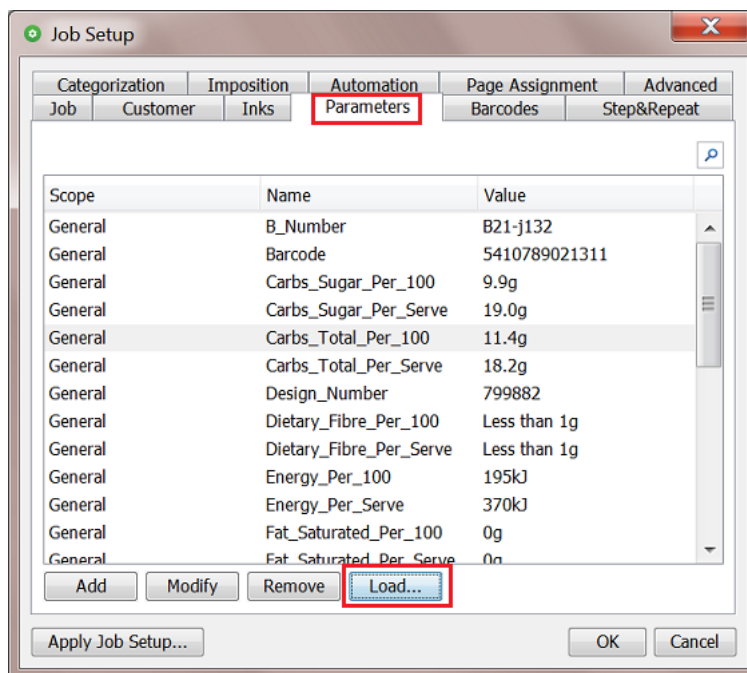

## 6.45. Create Flexo Plate Cutting Paths

The feature of creating Flexo Plate Cutting Paths is also present in ArtPro+.

It is an alternative to Staggered Cutting in ArtPro or PackEdge/Plato.

This task is described in the chapter [Flexo CTP Device Workflow](#) on page 1482.

Find a direct link [here](#).

## 6.46. Create IMP File (Classic)

Learn more in the dedicated document on "Commercial Print (Imposition) workflows in Automation Engine". Find it next to the "Complete Manual" of version AE **18.1** on <https://www.esko.com/en/Support/Product?id=Automation%20Engine&ver=18.1>.

## 6.47. Create Imposition from JDF Layout

Learn more in the dedicated document on "Commercial Print (Imposition) workflows in Automation Engine". Find it next to the "Complete Manual" of version AE **18.1** on <https://www.esko.com/en/Support/Product?id=Automation%20Engine&ver=18.1>.

## 6.48. Create Imposition from RunList

---

Learn more in the dedicated document on "Commercial Print (Imposition) workflows in Automation Engine". Find it next to the "Complete Manual" of version AE **18.1** on <https://www.esko.com/en/Support/Product?id=Automation%20Engine&ver=18.1>.

## 6.49. Create Job task

---

This task is documented in the chapter [Integrating with External Systems](#) on page 1769. Find a direct link [here](#).

## 6.50. Create Merged Plate

---

This task is documented in the chapter [Flexo CTP Device Workflow](#) on page 1482. Find a direct link [here](#).

## 6.51. Create Master DCS File (Classic)

---

This old technology is still supported but no longer commercially available.

Please find its documentation in the [manual of Automation Engine 14.1 or older](#) (as part of the Reference Guide).

## 6.52. Create Nested Layouts (Classic)

---

This task is documented in the chapter [Sign & Display Workflow](#) on page 953. Find a direct link [here](#).

## 6.53. Create or Modify WebCenter Project

---

This task is documented in the chapter [Integrating with WebCenter](#) on page 1741. Find a direct link [here](#).

## 6.54. Create Packshot from XML

---

**Concept**

Using an XML as input file, this task links one or more artwork files (PDF) with printable parts of a structural design file. A structural design file describes a 3D object.

Such XML is created by Esko WebCenter.

In this XML (in WebCenter), the user can specify:

- A scene and view preset. This determines at which angle one looks at the 3D object, if the 3D object should cast a shadow, which lighting environment is chosen etc.
- A finishing profile. This determines which special finishing operations should be visualized. For example a varnish, a holographic foil etc.
- The output file type: a TIFF, PNG, JPEG or Collada file.

## 6.55. Create PAF / JPG / XML (LinkEdge) (Classic)



**Note:** The name of this tool refers to "LinkEdge", an old interactive tool that was used to transfer files from the editor PackEdge between different sites.

This task packs the graphics data all its references in one file. It is also used to unpack that set of data, possibly at another site. This task is not just a form of Esko-'Zip': The (un)packing process also communicates with central resource folders (colors, fonts).

The task also offers to create a preview (JPEG) and/or a description of the file (XMP-XML).

You can also use the task to for example only create one of those 3 types of data.

### 6.55.1. Pack/UnPack

- Select **Create Packed File** to create a Pack file from a Normalized PDF or Plato PLA file (and legacy file formats GRS and GRQ).

When your ticket does not yet have an input file selection, you still need to choose the **Action**:

- **Pack File:** This creates a .PAFSC file (.PAF when input file was a legacy .GR\* file)



**Note:** 'PAF' refers to 'Packed Archive File'. The 'SC' refers to 'Scope', a term used in old Esko workflow setups.

- **UnPack File:** The output file is written in the ticket's **Output** folder. Where the referenced files are written depends on the option 'Unpack in...' below.
- You can choose to **Include Fonts**. When unpacking, the task first checks if the font is installed centrally. If so, the graphics file will refer to that central font. Otherwise, the font is installed locally.

- **Unpack in Local Directory:**

The **Local Directory** is the output path in the ticket. When none was specified there, it is the folder of the input file. This option is important when there are referenced files:

- When this option is not selected, the task will try to restore the original file structure. When a path to a reference is no longer relative but refers to other disk drives, these data will be put in a subfolder 'External'.
- When this option is selected, all elements of the packed file will be unpacked in the same output folder.

An example:

Suppose you packed a Normalized PDF (D: /Jobs/2345banana/2345\_50ml.pdf) which has one referenced image that resided in a subfolder (D: /Jobs/2345banana/images/banana.eps). When you unpack the PAFSC file and there select **Unpack in Local Directory**, the task will write all files in the same folder. If you unpack without that option, the task will try to re-create the same subfolder and put the image there. In this case, again in a subfolder /images.

- Add a **Password** to protect the Packed file. The user that unpacks that file will be prompted to enter the password (using a task ticket or using an interactive tool).

## 6.55.2. XML

Esko Normalized PDF files contain XMP metadata. Learn about its concept in the chapter [PDF Formats and Metadata](#) on page 44.

- Select **Extract XML Report** if you (also) want to create an XML description of the file's XMP metadata (job and customer data, references, inks, barcode, etc.).



**Note:** Native PDF data will first automatically be normalized according the ticket configured [here](#).

- **XML Structure:** Choose between standard XMP and the old **BackStage Version 1.2** (also based on XMP, but contains less information).

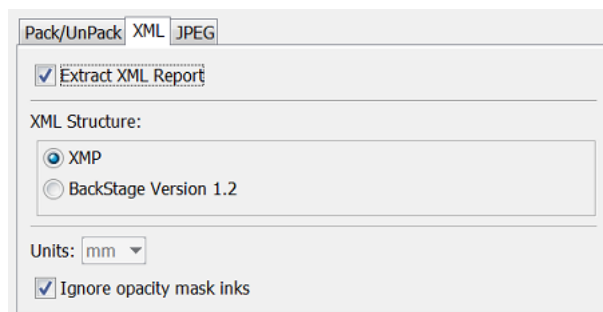



**Note:** Learn more about Esko XMP in the white paper "XMP Metadata in Graphic documents". Find it under "Related Documentation" [next to the Automation Engine documentation](#).

- Choose the **Units** that should be used in the XML file.
- Select **Ignore opacity mask inks** if you do not want information about such inks in the XML. Learn more about **opacity mask** in the user manuals of Esko or Adobe editors.

### 6.55.3. JPEG

Select **Extract JPEG Preview** if you want the task to (also) create a preview file of the (unpacked) input file.



**Note:** Native PDF data will first automatically be normalized according the ticket configured [here](#).

- Define an **Image Resolution**.
- Alternatively, you can define the JPEG's **Width** and **Height** in **pixels**. If your ticket already has an input file, these fields will already be filled in. Changing these fields may automatically reduce the chosen resolution.
- Alternatively, you can set **limits** to the JPEG's **Width** and **Height**. Changing these fields may automatically reduce the chosen resolution.
- Choose a **Compression** from the drop-down list.
- **Anti-aliasing** smoothens the staircase effect you get in the generated images of line-art objects. If you select it, also select its quality.
- Select **Account for Margins** if you want the JPEG to also contain data from outside the file's Trim Box ('borders'), so up to the file's Media Box ('margins').
- Select **Use varnish inks in output** if you want the inks with the attribute 'varnish' to be included in the JPEG file.

- **Page Range:** Choose if you want a JPEG of **All** pages or of a specified range of pages (for example '2-3, 5-6').

## 6.56. Create PDF File from JDF RunList (Classic)

---

Learn more in the dedicated document on "Commercial Print (Imposition) workflows in Automation Engine". Find it next to the "Complete Manual" of version AE **18.1** on <https://www.esko.com/en/Support/Product?id=Automation%20Engine&ver=18.1>.

## 6.57. Create PDF File from RunList

---

Learn more in the dedicated document on "Commercial Print (Imposition) workflows in Automation Engine". Find it next to the "Complete Manual" of version AE **18.1** on <https://www.esko.com/en/Support/Product?id=Automation%20Engine&ver=18.1>.

## 6.58. Create PDF Report

---

### Concept

This task is used to automate the creation of 'print cards' (in French: "fiche technique", in German: "Druckkarte").

These file reports typically contain a preview of the design and then lists extensive details of graphics and CAD and further information related to the job-order, customer, etc. It can even be extended to show separations or include 3D objects. Such file reports is what many prepress operators created manually and then printed to use as proofs or to store in some paper archive.

The task makes a report based on a **Report Template** that was made earlier in ArtPro+ and saved as a PDF+ file.

### Example

See this example of an output report PDF. Its format and content is decided by the **Report Template**, also the amount of pages. In this example the template had a second page where marks placed a closer view at some important details:

Report 15.06.2020 10:44 35.59%

Customer: GetWell bvba  
 Job Name: Medicine\_Syrup  
 Job Cat.: Prepress  
 Due Date: 09/26/17

File: GetWell\_Syrup.pdf  
 Associate: BGSYSTEM  
 Size: 364.50 x 261.00 mm  
 CAD: MEDICIN\_CARTON\_OPEN.ARD

Opaque White    Crease    Cut

Plates:	Inks:	Process:	Coverage:	Structural:	Barcode:
1	Opaque White	Underover Cuts 0 Home	4.59%	Crease	
2	Black	Underover Cuts 0 Home	1.73%	Cut	
3	PANTONE 172 C	Underover Cuts 0 Home	3.03%	emboss-deboss - detailed	
4	PANTONE Silver C	Underover Cuts 0 Home	0.58%		
7	Gloss Varnish	Underover Cuts 0 Home	4.59%		
<b>Details:</b>					
Software: Automation Engine 20.0.572 Last modified: 15.06.2020 Product ID: GetWell_Syrup Product Name: GetWell_Syrup Customer Ref.: GetWell Pharma Status: PrepressPreflightError					

Profile: Coated FOGRA39 (ISO 12647-2:2004)

Report 15.06.2020 10:44 100.00%

Customer: GetWell bvba  
 Job Name: Medicine\_Syrup  
 Job Cat.: Prepress  
 Due Date: 09/26/17

File: GetWell\_Syrup.pdf  
 Associate: BGSYSTEM  
 Size: 364.50 x 261.00 mm  
 CAD: MEDICIN\_CARTON\_OPEN.ARD

Detail 1    Detail 2

Detail 3    Detail 4



**Note:** In this version, this task still has these limitations :

- no support to place a 3D file
- no support for span mark
- Workflow parameters and Job parameters cannot be used in text marks.

### Graphics Kernel

This task uses the graphics kernel from ArtPro+ (NDL). The report templates also need to be created in ArtPro+. Learn more about PDF+ in [PDF+ in Automation Engine](#) on page 52.

This task succeeds the task [Create Report \(ReportMaker\)\(Classic\)](#), which uses the normalized PDF technology (BRIX), and which report templates have to be created in PackEdge.

### Functionality

- Select a PDF file.



**Note:** Normalized PDF is not supported as input file. In such case, use the task [Create Report \(ReportMaker\)\(Classic\)](#) instead.

- When selecting multiple input files, a task will be launched per input file.
- When an input file is a multi-page file, only its first page will be processed.
- Make sure to define a (smart) output name for the report PDF.

- Select a **Report Template** file that was created in ArtPro+.
- The result is a PDF.
  - Its content and number of pages are decided by the report template.
  - The report PDF contains a single layer ; all layers were flattened.
  - All its data is embedded and all its marks were flattened to static objects.



**Note:** This means that you can not ask the report PDF to update any links, like the link to the input-file.

### Creating a Report Template

How to create a report template for this task is described in the [user manual of ArtPro+](#), in its section **Working with Files > Report Template**.

To build such a report template in ArtPro+, you need experience in working with Dynamic Marks.

## 6.59. Create Report (ReportMaker)(Classic)



**Attention:** This task requires report templates made in Esko PackEdge. If you wish to work with native PDF templates, then check the task [Create PDF Report](#) on page 280.

This task is used to automate the creation of design 'print cards' (in French: "fiche technique", in German: "Druckkarte").

These file reports typically contain a preview of the design and then list all kinds of information related to the job-order, customer, extensive details of graphics and CAD. It can even be extended to show separations or include 3D objects. Such file reports is what many customers used to create manually and then print out or use as proofs.

The task makes a report based on a **Report Template**. Learn more below in [Creating a ReportMaker Template](#) on page 284.

### Input File types

- Input file types:
  - Native PDF
  - Normalized PDF
  - PDF+ files (since AE v18.1.1).



**Important:** PDF+ files will be normalized before the report is made.

The following features from PDF+ files are supported:

- ink properties and ink sequence
- Processing steps will be shown as technical inks.
- Text fields showing general properties
- dimension lines showing the document sizes
- text fields showing XMP properties
- 3D previews of PDF+ files containing links to ARD or Collada files (ZAE or DAE files)



- only when the CAD objects are rotated over a multiple of 90° are supported .

### Task Settings

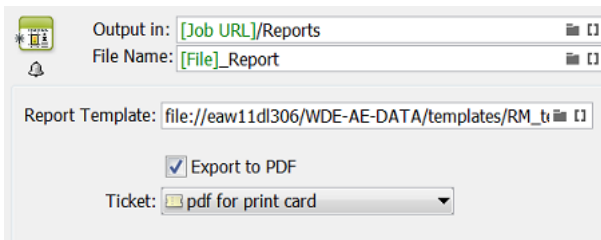

- To avoid that the output PDF has the same name as your input file, it is by default named [File]\_Report.pdf. Use SmartNames to define any other **File Name**.
- Select a **Report Template**.
- If you want your report to be a self-contained PDF instead of a Normalized PDF, select **Export to PDF** and choose a **Ticket** for the PDF Export task.



**Tip:** You can also use this option to help create a report containing a 3D object (see [Adding a 3D Object to a Report PDF](#) on page 288).

### Example

Here is an example of a report (viewed in Adobe Acrobat). The format and content is decided by the **Report Template**, also the amount of pages. This report template had a second page where SmartMarks place the design in separation mode:

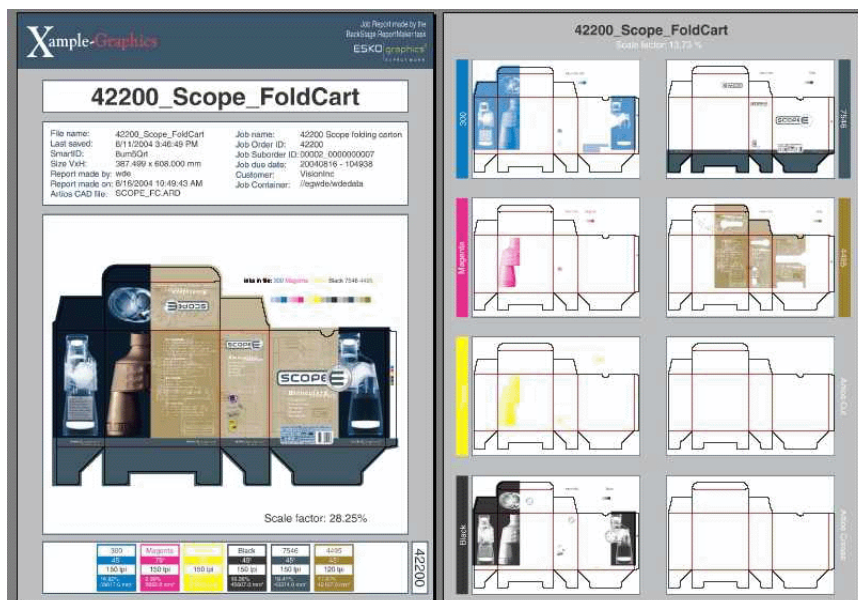

### 6.59.1. Creating a ReportMaker Template



**Remember:** You need the editor Esko PackEdge to make a template for the ReportMaker task.

A ReportMaker template is a Normalized PDF which you can design yourself. In this file, various specific **SmartMarks** are needed. Some of them use specific **SmartNames**.

Let's make a simple template that can give us this result:

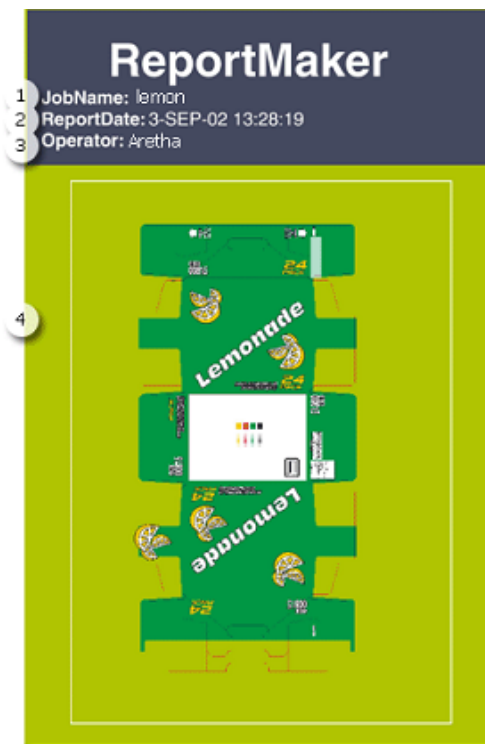

In the above example, 1, 2 and 3 are all **Text Marks** on board the template that are resolved when the ReportMaker task is executed. Number 4 shows a preview of the input file. This was placed via an **Image Mark** and can be scaled at wish.

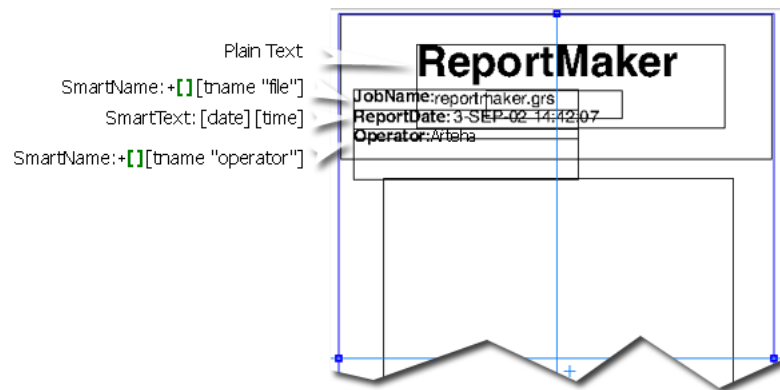

**Note:** SmartMarks used in a ReportMaker template are extra smart because:

- Ink related SmartMarks show the inks of the input file, not of the generated report.
- Ink coverage related SmartMarks show the ink coverage of the unscaled version of the input file.

Follow these steps to create a template for this task:

1. In PackEdge, create a new file that you will use as a report template.
2. Place the Text Marks. When needing help, contact Esko or check the [PackEdge user manual](#).
3. Draw a rectangle where you want the preview to appear (no need to attribute any color).
4. Make that rectangle a **Named Object**:

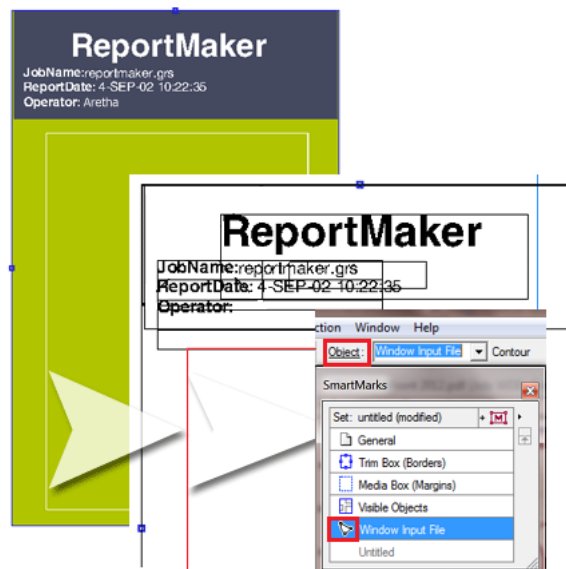

5. In the SmartMarks dialog, select that object, click + and add an **Image Mark**.
6. In the tab **Image**, the **Name** of the image is a special **Smart Text** for this case. Click + and choose '[taskinputfile]' from the category 'ReportMaker'. This is a special SmartName that will place the input file in the Report when so asked by a ReportMaker task.

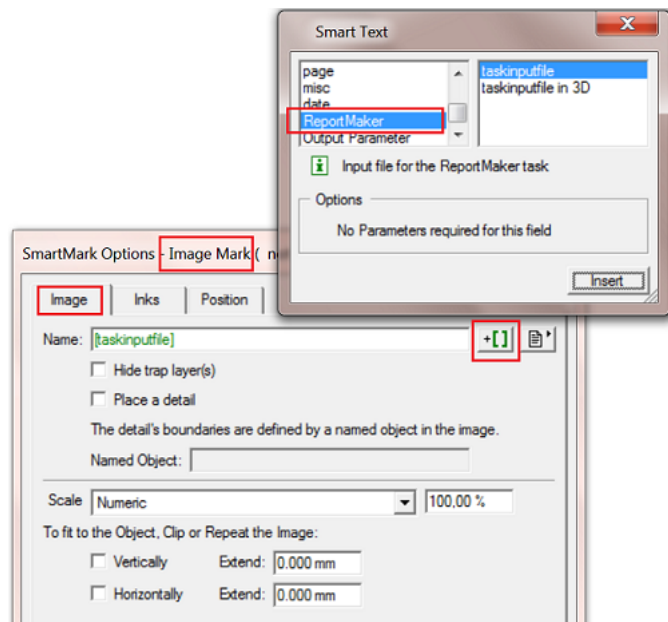

7. In the tab **Position**, **Attach** the Image Mark to the **Object** that you created in step 4:

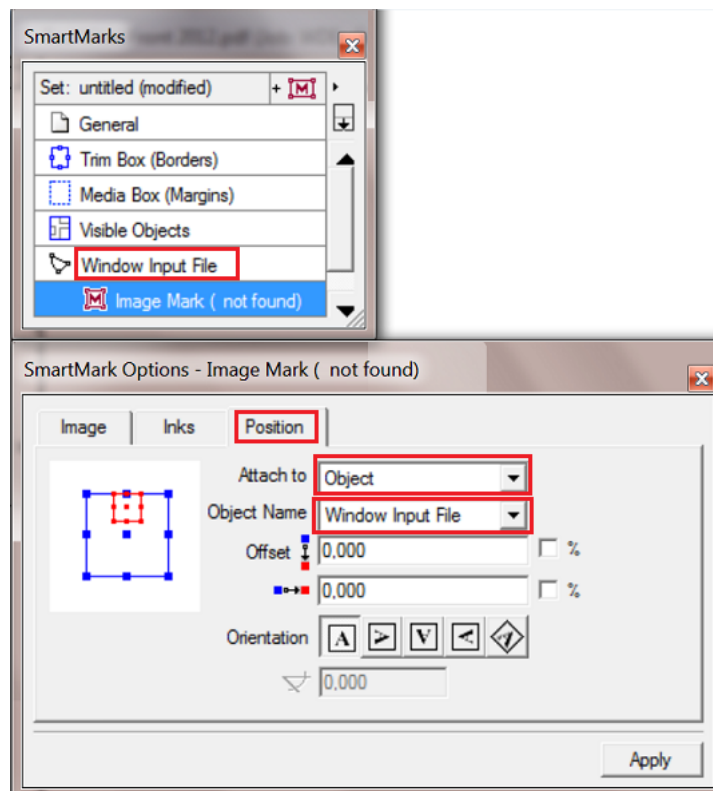

Notice how the Image Mark 'taskinputfile' has the same functionality as any other SmartMark. It can also be scaled, you can make ink-selections etc.

8. This is the result so far, the Image Mark places the 'taskinputfile' in the Named Object:

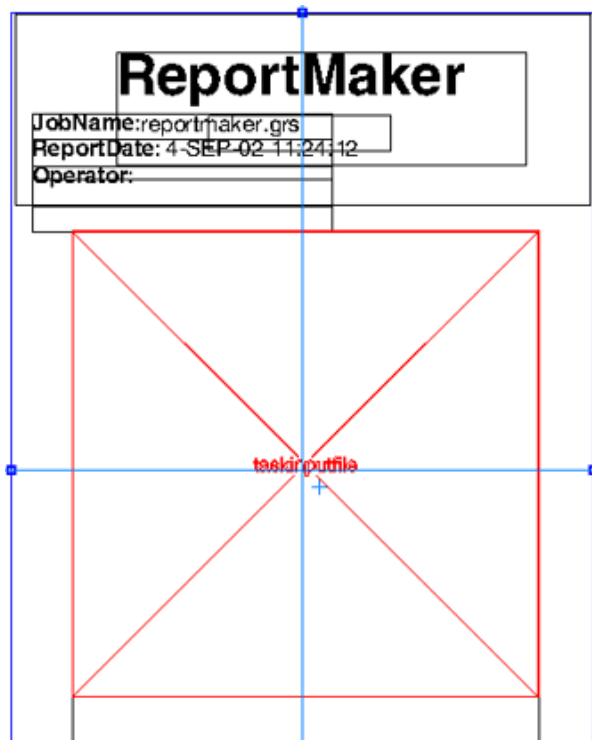

- 9. Save your PackEdge file.
- 10. Test it by using it as a ReportMaker template.

### 6.59.2. Adding Previews of Details in a Report PDF

The previews in a ReportMaker report can also zoom in on **'details'** of the input file. This makes it possible to add extra previews where you zoom in objects that are difficult to inspect in a full preview (ingredient copy, small logos, barcodes...). This is also useful when the design only contains few graphic objects, for example on corrugated boxes.

Here's an example where page 3 and 4 of the report zoom in on important content of the design:

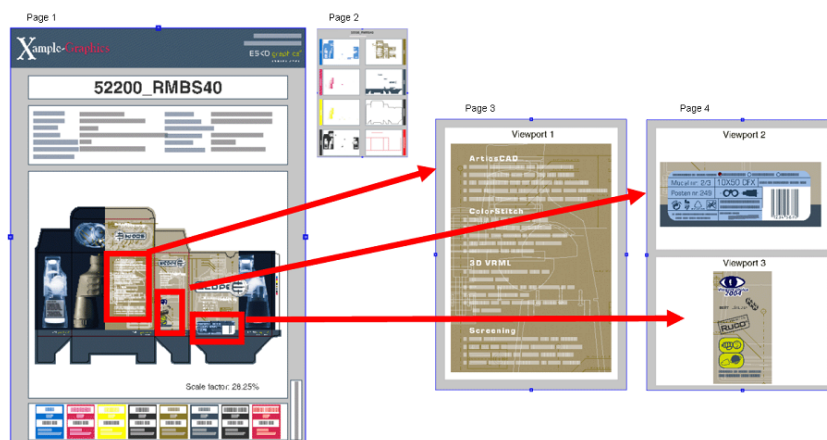

The way to do this is very similar to how you create the placeholder for the preview of the complete task input file, as described [here](#). In this case however, we will **place a detail** of the input file. These details are then attached to their own **Named Objects**. You can for example put these on extra pages of the template.

See below how page 4 of the template, that was used in above example, was set up:



**Attention:** Important is that in this case, the named objects that indicate the **details** first need to be set up in the *input* file. So before you launch the ReportMaker task, your input file needs to contain these Named Objects too.

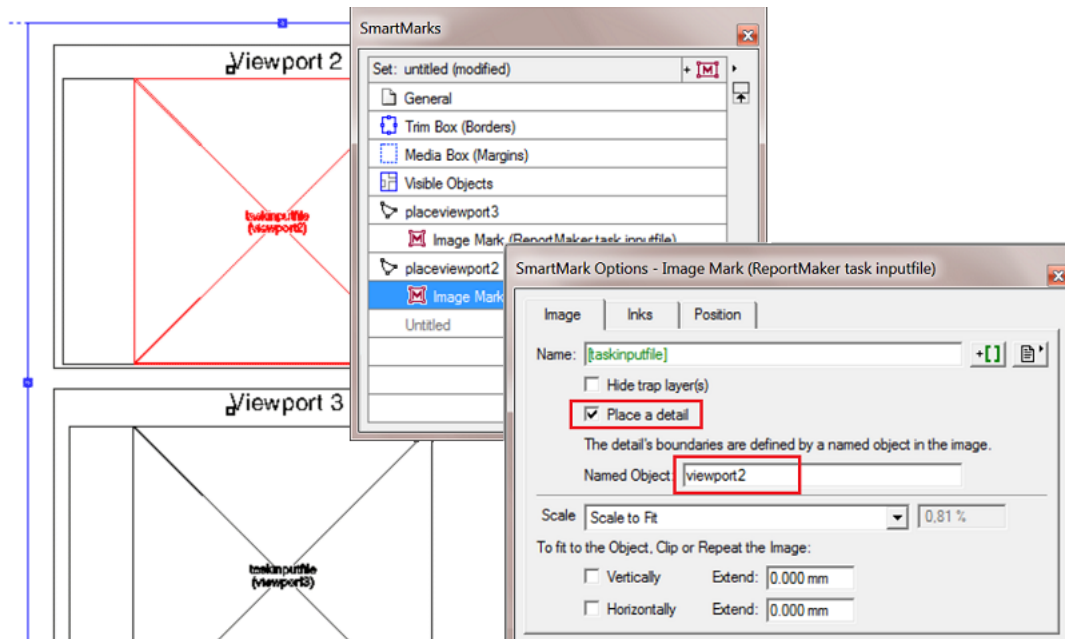

**Note:** A Named Object is typically a rectangle. This contour object is used as a clip mask on the input file. If the named object is a different object (an image, a group of objects...), then a clip mask will be applied with the size of the bounding box of the named object.

### 6.59.3. Adding a 3D Object to a Report PDF

A report PDF can even contain a 3D object of the input file. To do this, you need:

- a report template with image marks allowing 3D objects,
- a Normalized PDF file with a link to a CAD file (.ard, .dae or .zae).

Follow these steps:

#### 1. In PackEdge:

- a) Open your report template in PackEdge.
- b) Add a Named Object in which you want the 3D object to be placed.
- c) Add an Image Mark to that Named Object.
- d) Add Smart Text to define the name of the **Image**. From the category 'ReportMaker', choose '[taskinputfile in 3D]'.

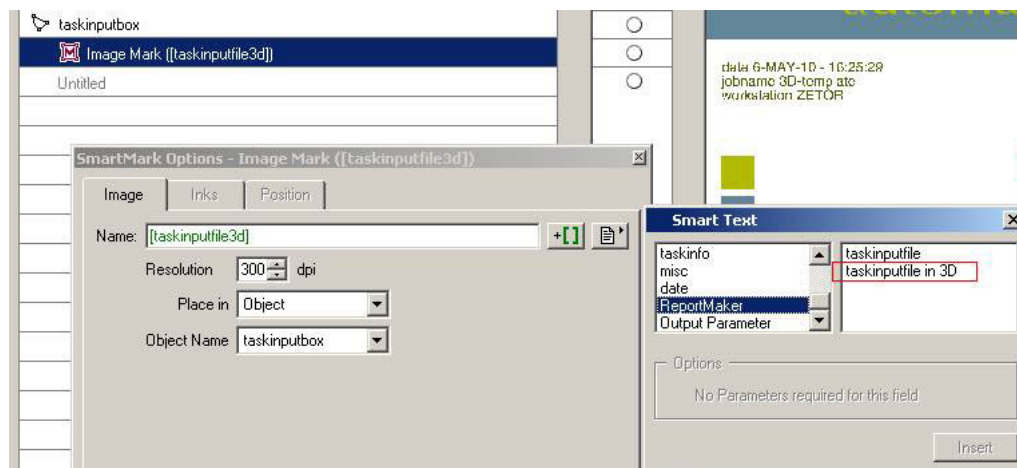

e) Save your template.

**2. In Automation Engine:**

- a) In the **Create Report** ticket, make sure you select the option '**Export to PDF**'. This forces the 3D object to be embedded in the PDF.
- b) This report PDF and its embedded 3D object can be viewed in Adobe Reader 8.0.1 or later.

## 6.60. Create RunList

---

Learn more in the dedicated document on "Commercial Print (Imposition) workflows in Automation Engine". Find it next to the "Complete Manual" of version AE **18.1** on <https://www.esko.com/en/Support/Product?id=Automation%20Engine&ver=18.1>.

## 6.61. Create RunList from PDF

---

Learn more in the dedicated document on "Commercial Print (Imposition) workflows in Automation Engine". Find it next to the "Complete Manual" of version AE **18.1** on <https://www.esko.com/en/Support/Product?id=Automation%20Engine&ver=18.1>.

## 6.62. Create Sheet Layout (Classic)

---



**Note:** Before v18.0.1, this task was named "Create CAD Sheet".

**Concept**

This task serves to fully automate the step & repeat process.

The task places graphic files on the **stations** that are defined in a template, which can be a CAD file, a PDFPLA file or layout description in a die database.

Which graphic files are placed is decided by the task's input file(s):

- If the input file is an XML file, this XML needs to contain information on what graphic file(s) to use, the quantity, bleed etc. Learn more in [Using XML as input file](#) on page 298.
- If the input file is a PDF file, the PDF is placed on all stations. If the input is multiple PDF files, the files will be distributed equally.



**Note:** These PDF can be:

- native PDF
- Esko Normalized PDF
  - Normalized PDF without CAD object info
  - Normalized PDF including CAD object info
    - CAD object info added from Adobe Illustrator, ArtPro, PackEdge or by the task [Load Structural File \(Classic\)](#) on page 369.
- a PDFSTA file.

Learn more in [Distributing the One Up graphics onto the Stations](#) on page 295 and [Positioning a One Up graphic onto a Station](#) on page 294.

### 6.62.1. Ticket settings

#### Tab 'General'

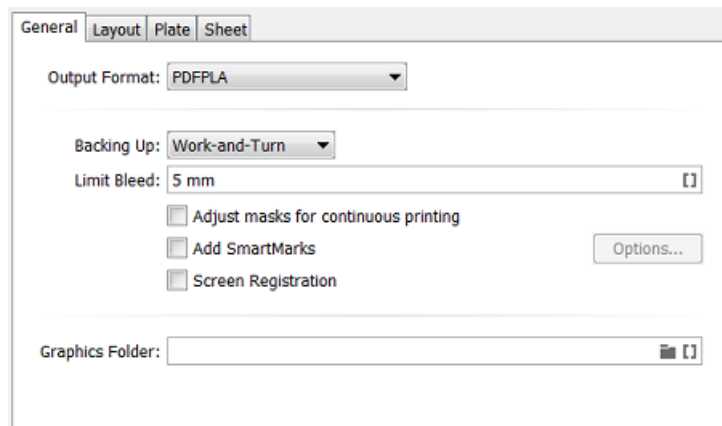

- The **Output Format** can be a PDFPLA, a Normalized PDF (with all references embedded) or a native PDF.



**Note:** When the input file is a native PDF and you here select PDFPLA, the task will fail.





**Note:** When the input file is a (native) PDF file and you choose to output to **'Normalized PDF (embed all)'** is selected, the input PDF will automatically normalized when while generating the output file. It therefore uses the 'Automatic normalization' ticket from the **Processing Preferences** in the **Configure** tool.

- The output file contains 2 layers: the CAD layer and a layer containing the placed stations. When SmartMarks are used, an extra layer will be generated containing the SmartMark objects.
- The output file will have a Trim box and a Media box. These page boxes represent respectively the sheet and the plate of the layout.
- The output file contains the following inks:
  - all the inks of the input files (in case the input files are native PDF files, a normalisation on-the-fly will be executed).
  - all the inks created during import of the CAD object
  - all the inks that might be added by SmartMarks.
- Use the **Backing Up** option when working with a front and back. You can choose to **Work-and-Turn** (rotate over a vertical axis) or **Work-and-Tumble** (rotate over a horizontal axis).



**Note:** In order to make a CAD sheet with a front and a back, you need a multi-page PDF file. The first page is placed on the front, the second on the back. In case of XML input, the XML file can contain [more detailed settings for the back side graphics](#).

- **Limit Bleed:** The bleed can be limited to a specific distance. The bleed mask is created by spreading the die shape. When this field is left empty, the bleed setting in the stations will be left unchanged.



**Note:** When using a SmartName, the resolved value should contain a number with an optional unit indicator. Supported unit indicators are (case insensitive): mm, cm, in, inch, mil, point, pt. When none was specified, the value is interpreted in mm.

- **Adjust masks for continuous printing:**

When not selected, the top and bottom rows can have more bleed (top- and bottom bleed) compared to graphics that occur in the middle of the layout.

When selected, the bleed of the top and bottom row of graphics will be truncated in the same way as on the rows in the middle of the layout (i.e. truncate the bleed of the top and bottom row of graphics as if there is a continuous set of rows of graphics). This is required to enable continuous printing (around the drum).

- Select **Add SmartMarks** if you want to add any.



**Note:** When a back side is created, SmartMarks will only appear on the back side if a SmartMark set was specified for that back side. In that case, the SmartMarks added on the front side will not be mirrored to the back side.

Click **Options...** and select them from the drop-down list or use SmartNames (**Front** and/or **Back**).

- By default, marks are loaded in a layer on top of the graphics. Select **Load Mark Set in bottom layer** if you want to make them appear behind the graphics, in a new layer at the bottom. This is used for example when adding gradation strips that need to run behind the graphics.
- Use **Pull back Marks** to keep marks away from the graphics. For example to keep gradation strips away from the die line, with a set distance. This option is only available when **Load Mark Set in bottom layer** was selected.

- **Screen Registration:** Select this option if the Esko RIP should reset the screening origin for every one-up. De-select it to keep the same screening origin for the complete step & repeat. This option is only available when outputting to PDFPLA or Normalized PDF (it is added to the XMP of those files).
- The **Graphics Folder** is the folder where the task searches the graphic files. This option is only applicable when the input mode of the task is XML and when the XML does not offer a full absolute path (only a partial path or only the name of the input file). Learn more in [Using XML as input file](#) on page 298.

**Tab 'Layout'**

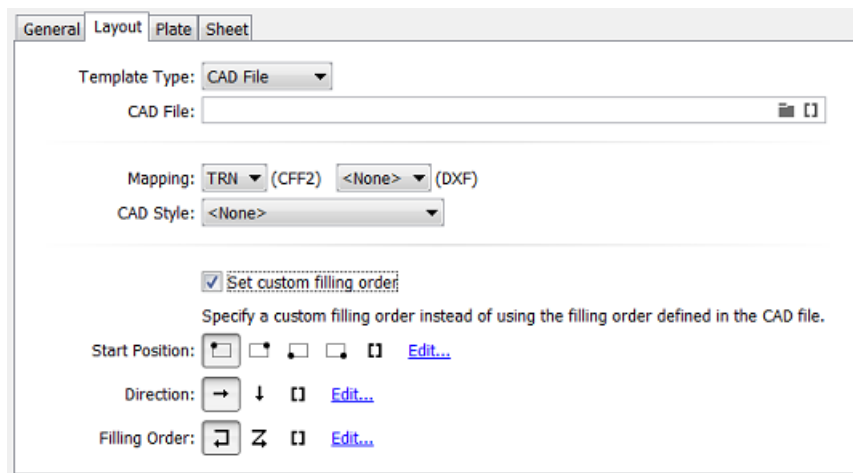

- **Template Type:** Choose between:
  - **CAD File:** Define the MFG, DXF or CFF2 file that will be used as base for this sheet.
  - **Mapping:** When the CAD file is a CFF2 or DXF file, you here select the set of mapping rules. These rules map line styles (cut, crease, bleed), layer names and color numbers onto ArtiosCAD line types. These sets of mapping rules can be created in Esko PackEdge or Plato. Learn more in [their user documentation](#), more specifically in their section on placing files (PackEdge) or on importing CAD data (Plato).
  - The **CAD Style** changes the appearance of the (imported) ArtiosCAD type lines.

 **Note:** This CAD Style is only applied on lines from the design (ARD) that was stepped in the layout file (MFG). Lines manually drawn next to the placed designs (the so called "objects at layout level") will always be ignored by the task.

The styles you can select here were also created in PackEdge or Plato. Learn more in [their user documentation](#), more specifically in the section on placing ArtiosCAD files, and the option for "CAD Style".

- **PDFPLA file**

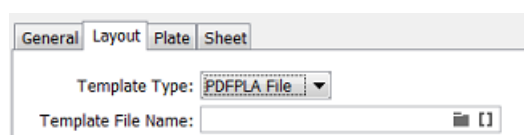

- **Die Database**

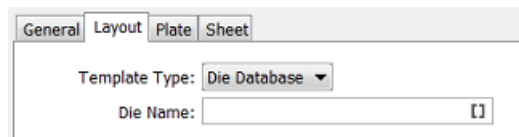

This is the die database used in the browser client of Automation Engine (the QuickStart deployment). Specify the name of the die that is described in there.

- **Filling Order** (valid for each type of Template):

- The filling order determines in which sequence stations will be filled with one ups. It also determines the value given by the SmartMark '**Station Number**'.
- The default filling order starts top left, vertical zig-zag per column.
- Select **Set custom filling order** to specify a filling order that is different than the one defined in the selected template file.
- The filling order is defined by selecting a **Start Position**, **Direction** and type of **Filling Order**. Learn more about using SmartNames to define these buttons in [SmartNames of Parameter Values](#) on page 729.



**Note:** The sequence of the designs is determined by taking the center points of the designs and sorting these in rows and columns. Keep in mind that designs with different sizes or layouts with staggered designs can result in more rows or columns than expected.

**Tab 'Plate'**

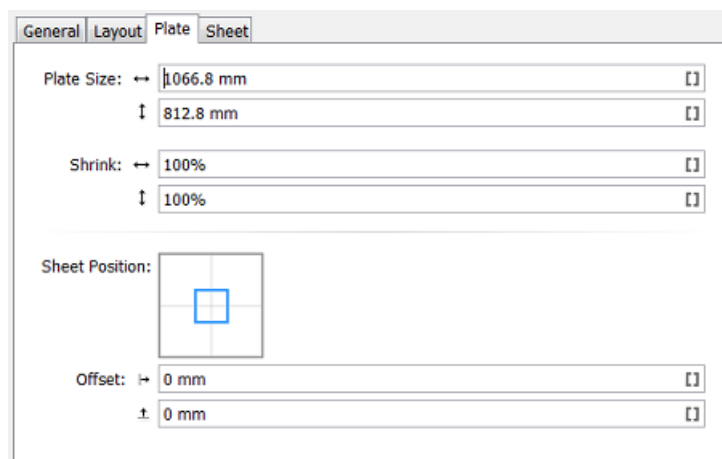

The sheet size can be automatically extracted from the CAD template but neither Artios MFG nor CFF2 file have a notion of 'plate'. As a result the plate size and position of the sheet on the plate have to be specified in this **Plate** tab.

- **Plate Size:** You here specify the plate's horizontal and vertical size.

- **Shrink:** To compensate for distortion on the output device or press, you can add vertical and horizontal shrink values.
  - When the output format is PDFPLA or Normalized PDF, this task writes the shrink factors in the file's XMP section. This means that the objects and page boxes keep their original sizes. These shrink factors will then be picked up by the RIP or export ticket, where they are used as scale factors and are applied on the complete document.
  - When the output format is native PDF, this task applies the shrink factors as scale factors on the complete document.
- **Sheet Position on Plate:** Position the sheet on the plate by dragging and dropping the blue square (the sheet) to the right position on the grey square (the plate).
- Define any extra horizontal and vertical **Sheet Offset**.



**Tip:** When using SmartNames, make sure they return a value that the field expects. For example a SmartName in the field 'Plate Size' should return a number.

**Tab 'Sheet'**

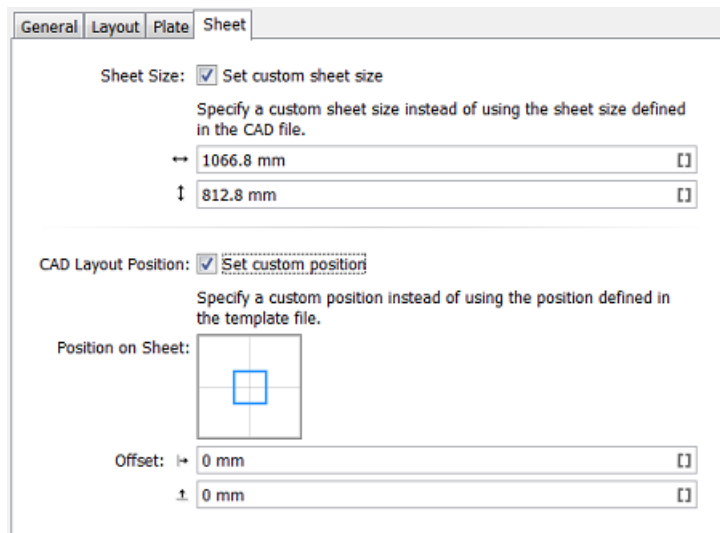

- If you want to use a custom sheet size instead of the **Sheet Size** defined in the CAD file, then select **Set custom sheet size** and enter its dimensions.
- **CAD Layout Position:** You here position the bounding box of all cut lines versus the sheet. If you want to use a different position for the CAD Layout than the one defined in the template file, then select **Set custom position**.
  - **Position on Sheet:** Click or drag the blue square (the CAD Layout) in a position versus the grey square (the sheet).
  - **Offset:** Define by how much the CAD Layout should be offset from the sheet corner, horizontally and vertically.

**6.62.2. Positioning a One Up graphic onto a Station**

To decide how to position a PDF onto the CAD file, the task tries these options, in this order:

1. Checks if the input PDF contains a die cut object, a linked ARD file. If the name of this ARD file matches the name of the design specified in the MFG file, the graphics will be placed.



**Note:** This option is only available for Normalized PDF files.

2. Positions the Trim Box of the PDF on the bounding box of the cut and crease lines. If the Trim Box and bounding box match, the graphic will be placed.
3. Positions the die line of the PDF defined in the XML file, on the bounding box of the cut and crease lines. If it matches, the graphic will be placed.



**Note:** This option is only available when the task input file is an XML file.

If the PDF Trim Box or die line bounding box does not match any of the bounding boxes of the design in the CAD file, then the file will not be processed and an error will be given.

### 6.62.3. Distributing the One Up graphics onto the Stations

Which PDF goes onto which position in the CAD layout?

- When the input file of the task is an **XML** file, the task looks for an XML element **Quantity**, defining the amount of stations to be filled with that specified graphic. For example `<Quantity>10</Quantity>`.



**Note:** If the total number of quantities doesn't match the number of stations, the task will stop with an error.

When the element shows the value `<Quantity>Maximum</Quantity>`, the task will place the referred PDF file as many times as possible.

When more than one PDF file has the quantity element set to **Maximum**, the task will distribute the referred PDF files equally. You can also combine files with a fixed quantity with one or more files with a quantity set to **Maximum**.

- When the input file of the task is a set of PDF files, the task will consider all PDFs to be set to **maximum** quantity, so the provided input files will be distributed evenly onto the provided CAD layout.

When the number of available stations cannot be divided by the number of input files (for example 9 stations and 2 PDF files), the task will automatically distribute the remaining stations.

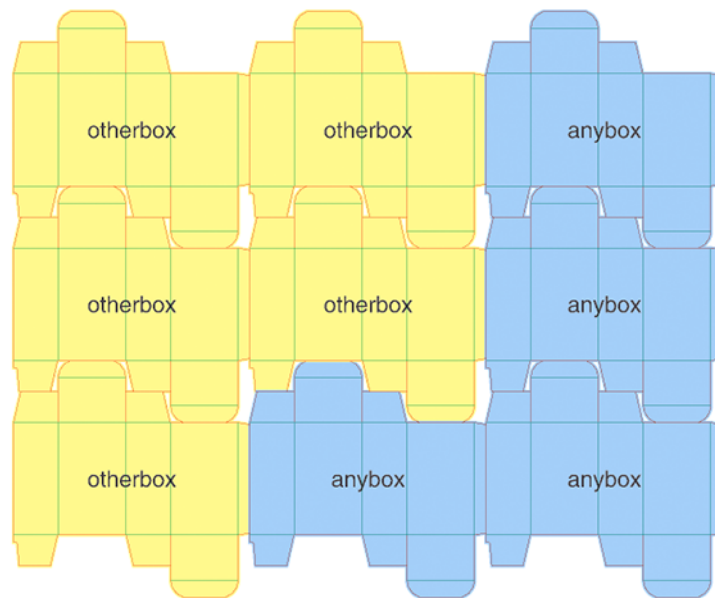

**Note:** When the CAD file contains different designs (different types or sizes of boxes), the graphics will only be distributed on the corresponding (fitting) designs (see [Positioning a One Up graphic onto a Station](#) on page 294).

### 6.62.4. Bleed and overlap

When the one-up graphics contains bleed, this bleed will be used around the die line, limited by the value in **Limit Bleed** (in the **General** tab).



**Note:** Everything outside the die line is considered to be bleed. Bleed zones without content will knock out when overlapping. Overlaps can only work well if a correct bleed limit is applied.

When the bleed of two stations overlap, you can have these situations:

- There is a gap between the panels of the two stations.  
In this case, centerline overlapping is applied: the bleeds from both neighboring stations touch on the center-line of the gap.
- The station panels are touching.
  - If the layout is not CAD based, centerline truncation is applied.
  - If the layout is based on a CAD template, then:
    - the biggest panel will overlap the smaller panel (situation A in the example below).
    - if the panels are the same size, centerline overlapping is applied (situation B in the example below).
    - in case the ArtiosCAD artwork panels were given a specific '**Allow Bleed**' property, other rules apply. Learn more in [Bleed Overlap Priority decided by ArtiosCAD Artwork Panels](#) on page 297.

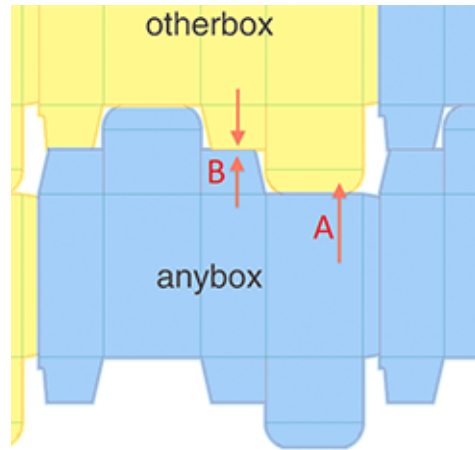

**Note:** When deciding if a station is touching another station, minor tolerances are taken into account to cope with small inaccuracies in the die cut file.

### 6.62.5. Bleed Overlap Priority decided by ArtiosCAD Artwork Panels

The priority in bleed overlap can be automatically decided in case the layout is an MFG and in case there are common knives (i.e. no gutters, so areas where 2 panels/flaps touch). The decision is then based on how the ArtiosCAD user defined the bleed direction for those specific panels.

In ArtiosCAD, a panel can be defined as an **'artwork panel'** and an artwork panel can have an **'Allow bleed'** property. A panel that is set to allow bleed is considered as having a minor priority and it can receive bleed when it touches another panel marked as major priority (where **'Allow bleed'** was not defined or turned off). In the case 2 minor panels are touching, the bleed will be truncated to the centerline, which is the default behavior, like in areas where there are gutters (i.e. no common knives).



**Note:** This behavior applies to all Step & Repeat tasks using an MFG layout (including in classic editor Esko Plato).

**Overview of all Possible Situations:**

- In case there is a gutter: always centerline truncation.
- In case there is no gutter between 2 panels (gutter = 0), the following overview applies:

**Table: Smart Flapping**

Panel 1	Panel 2	Bleed Action
Not an artwork panel	Not an artwork panel	Compare size of Panel 1 and Panel 2. If size difference > 10%, then large one bleeds into smaller one, otherwise centerline is used
Not an artwork panel	Artwork panel with allow bleed = 0	Centerline (i.e. no bleed as the gutter = 0)
Not an artwork panel	Artwork panel with allow bleed = 1	Panel 1 bleeds into Panel 2

Panel 1	Panel 2	Bleed Action
Artwork panel with allow bleed = 1	Artwork panel with allow bleed = 1	Centerline (i.e. no bleed as the gutter = 0)
Artwork panel with allow bleed = 1	Artwork panel with allow bleed = 0	Panel 2 bleeds into Panel 1
Artwork panel with allow bleed = 0	Artwork panel with allow bleed = 0	Centerline (i.e. no bleed as the gutter = 0)
Artwork panel with allow bleed = 0	Artwork panel with allow bleed = 1	Panel 1 bleeds into Panel 2

### 6.62.6. Using XML as input file

#### Concept

When the business system (MIS, ERP) provides an XML description, this task can fully automate the folding carton step & repeat process.

When using XML input file(s), the task supports 2 modes:

- An v18.0 compatible mode supporting the XML format. Advantage of this mode is that you can use the Product ID. This is used for example in flexo printing. Learn about this XML specification below.
- A mode which is compatible with the XML used in the Step & Repeat tasks (excluding the 'classic' ones). Advantage of this mode is that you can specify a page range (in case your input file is a multi-page file). This is used for example in VDP. Learn about this XML specification below.

#### Specification

In the 18.0 compatible mode, the task scans the XML file for elements called <JOB>. Multiple <JOB> nodes are allowed when these are placed under a <JOBS> node.



**Attention:** All XML elements are case sensitive. For example, the element <JOB> must be in capital letters.

An example:

```
<?xml version="1.0" encoding="UTF-8"?>
- <JOB>
  <FileName>\\homer\beou_container\beou_CAD_demo\Input\demo\anybox.pdf</FileName>
  <Quantity>7</Quantity>
  <Bleed>2.0</Bleed>
</JOB>
```

It's also possible to combine multiple graphics in the XML file. In that case, multiple <JOB> elements are gathered in one <JOBS> element. An example:



```
<?xml version="1.0" encoding="UTF-8"?>
- <JOBS>
  - <JOB>
    <FileName>\\homer\beou_container\beou_CAD_demo\Input\demo\otherbox.pdf</FileName>
    <Quantity>2</Quantity>
    <Bleed>2.0</Bleed>
    <Page number="1"/>
  </JOB>
  - <JOB>
    <FileName>\\homer\beou_container\beou_CAD_demo\Input\demo\anybox.pdf</FileName>
    <Quantity>7</Quantity>
    <Bleed>2.0</Bleed>
    <Page number="1"/>
  </JOB>
</JOBS>
```

Each <JOB> element will create in a station according to it's sub elements:

XML Element	Description
Filename (mandatory)	<p>URL of the graphics. Both URLs and UNC paths are supported. Both absolute URLs and relative URLs are supported. In case the URL is relative, the <b>Graphics Folder</b> specified in the ticket is used to resolve the URL of the graphics. Only one of <b>FileName</b> or <b>ProductID</b> may be specified. Some examples:</p> <pre>&lt;FileName&gt;file://myserver/myfolder/mygraphics.pdf&lt;/FileName&gt;</pre> <pre>&lt;FileName&gt;\\myserver\myfolder\mygraphics.pdf&lt;/FileName&gt;</pre> <pre>&lt;FileName&gt;mygraphics.pdf&lt;/FileName&gt;</pre> <pre>&lt;FileName&gt;myfolder\mygraphics.pdf&lt;/FileName&gt;</pre>
Product ID (mandatory if Filename is not used)	<p>ID of the Product to use for the graphics. Only one of <b>FileName</b> or <b>ProductID</b> may be specified. If a product contains multiple parts, the first part is used. The second part will be used (if present) as back side graphic.</p> <div style="border: 1px solid gray; padding: 5px;">  <b>Note:</b> Describing products with multiple <b>Parts</b> in this way is not yet possible in this version.         </div>
Quantity	<p>Number of times the graphics needs to be placed. Allowed values are either a number or the keyword "Maximum" (the default, case insensitive, can be abbreviated to "Max"). In case multiple graphics are using 'quantity = maximum', they will be evenly placed on the number of matching placeholders.</p>
DieShape	<p>Ink name of the die line of the graphics. Allowed values:</p> <ul style="list-style-type: none"> <li>the name of a spot color,</li> <li>'TRIMBOX' (or 'BORDERS') will use the trim box of the PDF graphic.</li> <li>'DEFAULT' will search for a CAD object inside the normalized PDF(STA) file. When no CAD object is found, the trim box will be used. This also the default value of this element.</li> </ul>
Bleed	<p>The amount of bleed allowed outside the die shape. Sets a bleed mask, in mm, starting from the die line. When no bleed is specified, no bleed mask will be applied, unless the input is a PDFSTA file, in this case, the bleed setting from the PDFSTA file will be used.</p>

XML Element	Description
Page number	Select a specific page from the specified PDF graphic. If no page is specified, all pages of the graphics file will be loaded. Y

### Specification for the <Runlist> Mode - compatible with Dynamic Step&Repeat



In the **Dynamic Step&Repeat** compatible mode, the task will scan the XML file for elements called <RunList>, which contain one or multiple <RunListItem> nodes.

A <RunListItem> node consists of the following sub-nodes:

Node	Description
FileName	URL or UNC of the PDF graphic to be placed. Relative URL's are allowed, the 'Graphics Folder' will then contain the base path.
Repeats	Number of copies required for this graphic. Allowed values are either a number or the keyword "Maximum" (case insensitive, can be abbreviated to "Max").
FirstPage	Number indicating the first page of the graphics to be used. Learn more in <a href="#">Specification of RunList XML in Step &amp; Repeat tasks (= excl. the Classic ones)</a> on page 496.
LastPage	Number indicating the last page of the graphics to be used. Learn more in <a href="#">Specification of RunList XML in Step &amp; Repeat tasks (= excl. the Classic ones)</a> on page 496.

### Extra XML Parameters when working Front and Back Graphics

Table: Back side handling in XML (all optional)

XML Element	Description
BackGraphic	<p>UNC (or URL) of the PDF file to be used as back side. Example:</p> <pre>&lt;BackGraphic&gt;file://myserver/myfolder/mybackgrphic.pdf&lt;/BackGraphic&gt;</pre> <p> <b>Note:</b> No page selection is possible for the back graphic. Only the first page of the back graphic PDF is used)</p>
RectoVerso	<p>Allowed values: 0: use all pages as front, 1: use the even pages of a multi-page file on the back.</p> <p> <b>Attention:</b> The default value is &lt;RectoVerso number="1"/&gt;. In other words, even when the XML file does not contain a setting for backside and the supplied graphic is multi-page, the even page(s) will be used as back side graphics.</p>
SameGraphic	<p>The default value is '0'. This indicates that the front graphic should also be used as the back graphic. Allowed values: 0 or 1: use the same graphic on front and back. Example:</p> <pre>&lt;SameGraphic number="1"/&gt;</pre>

XML Element	Description
	SameGraphic is overruled by RectoVerso in case of a multi-page file.
FlipGraphic	<p>Only to be used in combination with &lt;SameGraphic&gt;. When value = 1, in combination with 'SameGraphic' = 1, then the front graphic will also appear on the back but flipped around a vertical axis. Example:</p> <pre>&lt;FlipGraphic number="1"/&gt;</pre>

Other nodes as listed above (DieShape, RectoVerso, SameGraphic, FlipGraphics, BackGraphic) are optional.

## 6.63. Create Sheet Report from IMP File (Classic)

Learn more in the dedicated document on "Commercial Print (Imposition) workflows in Automation Engine". Find it next to the "Complete Manual" of version AE **18.1** on <https://www.esko.com/en/Support/Product?id=Automation%20Engine&ver=18.1>.

## 6.64. Create Tiles (Classic)

This task is described in the chapter on *Gang Run Printing*. Find a direct link [here](#).

## 6.65. Create Wrapper File (Classic)

### Concept

The task wraps the input file(s) in a Normalized PDF. This is typically used to encapsulate screened TIFF ('Copydot') files into a PDF format before further tasks are launched on that PDF.

This task accepts these types of images as input files: TIFF, TIFF\_IT, PSD, JPG, BG\_CT, BG\_LP, BG\_JS, EPS, DCS, Copydot, LEN.



**Note:** This task does not support LENX files.

**Combine multiple input files (separations) to a single composite wrapper file:** This is the default behavior with multiple input files. Learn more in [Separations tab](#) on page 303.

### 6.65.1. Page Size tab

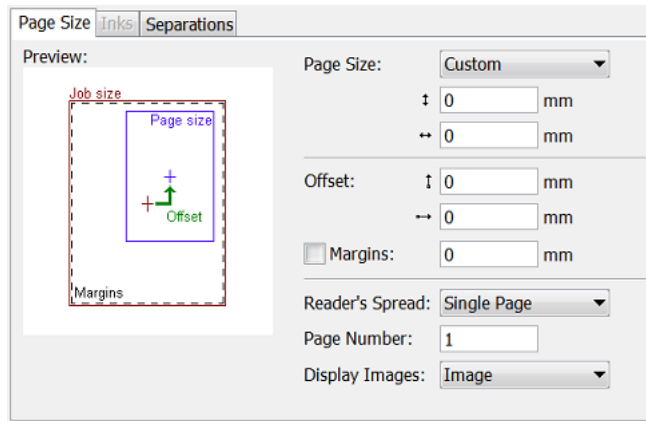

- **Page Size:** You here define the size of the output file.
  - **Job size:** This is the size of the input file.
  - Choose **Custom** to define a size manually.
  - Or select a standard size from the list.



**Note:** About '**Scanner Trim Size**': All 'Eskoscan' scanners have a feature to indicate the trim size of the page (they add it into the master DCS file). When choosing 'Scanner Trim Size', the borders of the output file will be automatically positioned.

- **Offset:** When no offset is defined, the center of the 'image' will be positioned on the center of the page. If the page is smaller than the image (width, height, or both), then margins will be set that enclose the image completely. The size of the margins will not be fixed. Margins indicate the differences between the image size and the user-defined page size.
- Select **Margins** and define its values to set fixed size margins to the PDF (for example 3 mm for bleed).
- **Reader's Spread:** None of the supported input file types have the notion of 'reader's spread'. Select this when you want to use the output PDF in Esko FastImpose.
  - **Single Page** forces a single page output file.
  - **Reader's Spread** forces a reader's spread output file, set as double pages.
  - **Auto** checks the size of the input file: When its width equals or exceeds two times the selected page width, the reader's spread option is set. Otherwise it is treated as a single page.
- **Page number:** Select the correct page number from the output PDF that you want to output.
- **Display images:** Select the preview settings of the output PDF.

## 6.65.2. Inks tab

This tab serves to add ink attributes to inks that can be detected from the input file.

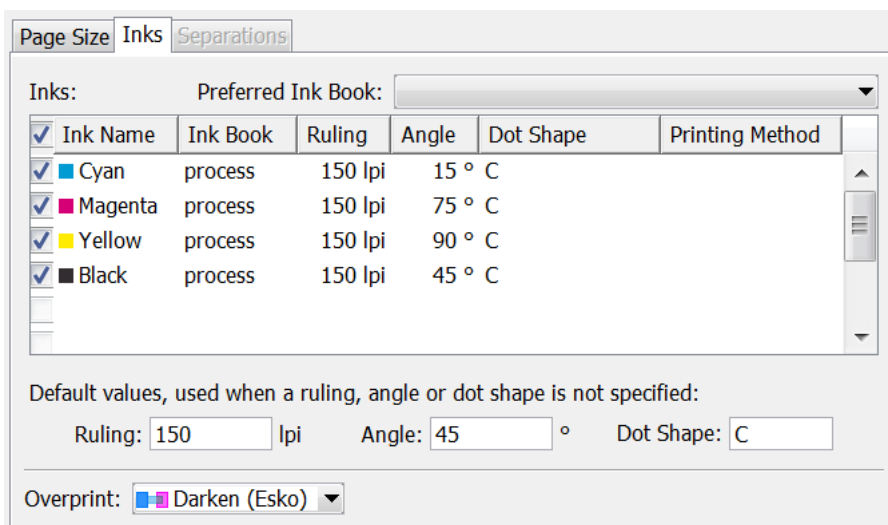

**Note:** This tab is greyed out when you selected the option 'Combine multiple input files (separations) to a single composite wrapper file'.

If an input file contains definitions for its ink (for example a CMYK Tiff or a Photoshop DCS2), and this definition matches an **Ink Name** defined in this tab, then the **Angle**, **Ruling**, etc. in the output PDF will be the ones as set here for this ink name. All other inks will get the attributes as set in the **Default** options set below.

This tab by default contains **CMYK**. You can change at will manually.

Inks in this list can be selected or not. Not selected inks will be ignored by the task.

When an input file has no ink definition:

- If only one ink is selected in this tab, the output PDF will contain that ink, including all its attributes as here specified.
- If multiple inks are selected, and **K** is part of that selection, the output PDF will contain **K** and its attributes as here specified.
- If multiple inks are selected and **K** is not part of that selection, the output PDF will contain the first ink from this list and its attributes as here specified.
- If no ink or the wrong ink is selected (one that cannot be found in the Pantone or Designer book), then the output PDF will contain **K** with the **Default** attributes.
- If the wrong ink is selected, together with the default ink, then the output PDF will contain the attributes from the default ink.



**Tip:** In **Preferred Ink Book**, choose the ink book that you use most frequently. When you then type an ink name in the table, the task searches for this ink in your preferred ink book first. For example, if you type the ink name '154' and your preferred ink book is set to **Pantone Colors Uncoated**, the task will automatically suggest the ink 'PANTONE 154 Uncoated'.

**Overprint:** Select one from list. Learn more in [Overprint](#) on page 389.

### 6.65.3. Separations tab

This tab serves to define which ink each of the input files should be attributed:

Wherever possible, the task will try to define the ink automatically.

If you want to overrule these, select the **Ink Type** and name yourself.

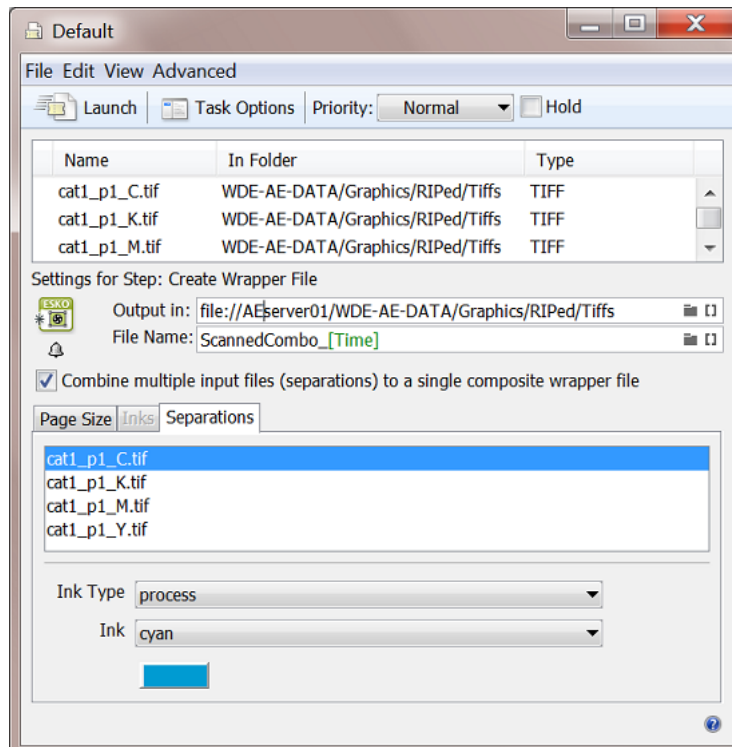

## 6.66. Create XML File

---

This task is documented in the chapter [Integrating with External Systems](#). Find a direct link [here](#).

## 6.67. Crop LEN File

---

This task is documented in the chapter [Flexo CTP Device Workflow](#) on page 1482. Find a direct link [here](#).

## 6.68. Data Collector

---

This Workflow Control is documented in the chapter "Workflows". See [Data Collector](#) on page 829.

## 6.69. Data Splitter

---

This Workflow Control is documented in the chapter "Workflows". See [Data Splitter](#) on page 835.

## 6.70. Delete File

---

This task is mostly used at the end of a workflow ticket, where the original input may be deleted since the workflow has created other data that are more worth keeping..



**Tip:** This task can also be combined with the **Wait** task. For example: first wait 2 hours, then delete the marked file.



**Tip:** To delete marked files, you can perform the following actions: **Mark File** + any other action + **Select Marked File** + **Delete File**.

## 6.71. Delete Inactive Job

---

This task relates to near-line storage for AE SaaS customers.

Learn more in the chapter [AE SaaS: When your AE is in a Data Center](#) on page 1633, in the section about [Inactive Jobs](#), on the page [Task 'Delete Inactive Job'](#) on page 1655.

## 6.72. Delete Product on Esko Cloud

---

This task relates to near-line storage for AE SaaS customers.

Learn more in the chapter [AE SaaS: When your AE is in a Data Center](#) on page 1633, in the section about [Storing Products on Esko Cloud](#) on page 1658, on the page [Task 'Delete Product on Esko Cloud'](#) on page 1665.

## 6.73. Download Files from Shared Job

---

This task is documented in the chapter [Sharing to Collaborate with other AE servers](#) on page 1685. Find a direct link [here](#).

## 6.74. Download Product from Esko Cloud

---

This task relates to near-line storage for AE SaaS customers.

Learn more in the chapter [AE SaaS: When your AE is in a Data Center](#) on page 1633, in the section about [Storing Products on Esko Cloud](#) on page 1658, on the page [Task 'Download Product from Esko Cloud'](#) on page 1664.

## 6.75. Download WebCenter Document

---

This task is documented in the chapter **Integrating with WebCenter**. Find a direct link [here](#).

## 6.76. Enrich Black (Classic)

---

This task creates "rich black" areas. Typically cyan is added to make black areas more black. You can also use this task to enrich areas in other inks than 'process black'.

This task uses the trapping technology as used in the task [Trap with PowerTrapper \(Classic\)](#). It also scans and then creates (overprinting) objects, which is stores in an extra layer named "Trapping".

In the example below, 80% Cyan is added to all areas containing pure black, resulting in an enriched black:



- [General tab](#)
- [Scan tab](#)

### 6.76.1. General Tab

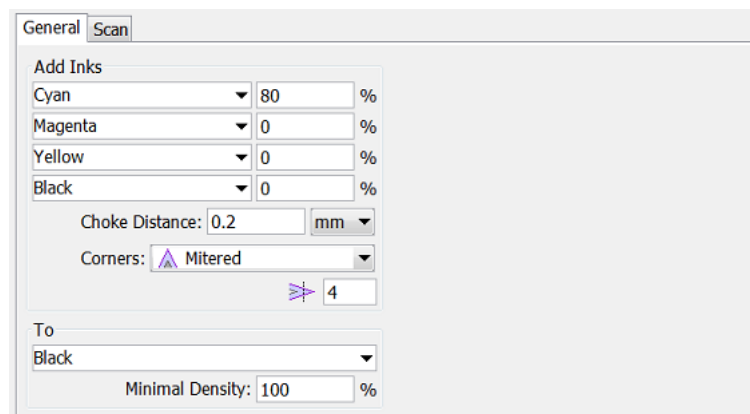

- **Add Inks:** You here define what color will be added. This color can contain up to four inks. Typically 80% C is added to generate rich black, or a more neutral combination of CMY such as 60% C 40% M



40% Y. Alternatively, you can type in the name of any other ink. When the percentage next to an ink name is set to 0%, the ink will not be used.

- **Choke Distance:** To prevent registration errors on the press, you here define a value so that the generated objects in the added color will be smaller than the original (black) area. This value is the distance between the edge of the area in the defined color and the edge of the original (black) object.



**Note:** In the task *Trap with PowerTrapper (Classic)*, this option is named **Pull Back**.

- **Corners:** You here specify how sharp corners should be handled.
  - **Mitered:** If the distance from the base of the trap to the corner point is larger than the **Miter Ratio** multiplied by the trap distance, then the corner will be **beveled**. Otherwise, it will remain sharp.
  - **Round:** All corners end in a round cap.
  - **Beveled:** See this cut-off shape in the graphic:

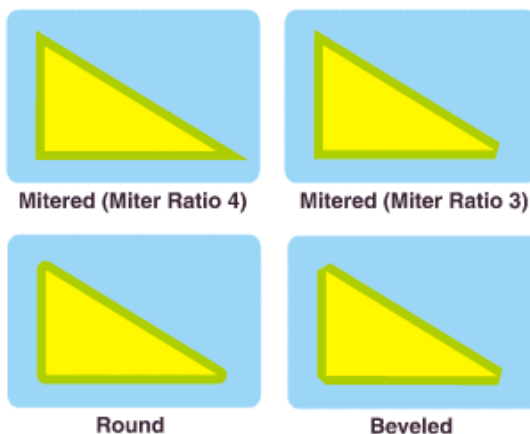

- **To:** Define the color of the objects that you want to enrich with the above set ink(s). This ink is typically Process Black. Alternatively, you can type in the name of any other ink.
  - **Minimal Density:** Define the minimum percentage that the **To** ink needs to have in an area before the specified color will be added to that area.

## 6.76.2. Scan Tab

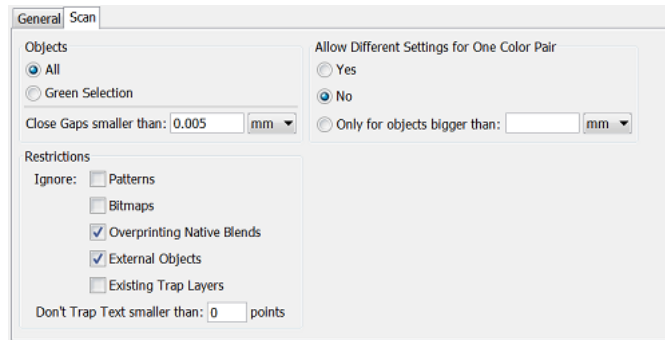

- **Objects:**
  - **All:** All objects in the file will be considered.
  - **Green Selection:** Only objects that were saved as a green selection in PackEdge will be considered.
  - **Close Gaps smaller than:** Learn more in the page on the task [Trap with PowerTrapper \(Classic\)](#).
- **Restrictions:** Define which objects can be ignored (this also speeds up the task):
  - **Patterns:** Ignores native "fill and stroke" patterns. Prior to creating the new objects, fill patterns are converted to contours. Fine patterns can so result in a huge number of contours, making this a long and memory heavy task.
  - **Bitmaps:** Ignores bitmap pixel data. This type of data is also contourized before the new objects are created, which can slow down the task.
  - **Overprinting Native Blends:** This option is only used in a DeskPack workflow. Certain native Adobe Illustrator blends cause performance issues. You may ignore these because they have little or no effect on the result of this task.
  - **External Objects:** Ignores references to external Normalized PDF files (or legacy GRS, LC, and LP files). When this option is not selected, the external references are degraded to internal objects prior to creating the objects.
  - **Existing Trap Layers:** Ignores any already existing layers created by this task. This option is useful when re-launching this task on a file that already has such a layer.
  - **Don't Trap Text smaller than:** Small text must be kept as sharp as possible. The task risks to blur the sharp edges of small characters, making them harder to read.  
 The default value is 0 points ; it then creates objects for all text. 1 point equals 1/72 of an inch.  
 This option only affects *live* text objects, not contourized text.
- **Allow Different Settings for One Color Pair:**

The task can generate a different "trapping" action for different occurrences of a same color pair.

  - **Yes** is the default value.
  - Select **No** to force the task to apply one identical action to all the occurrences of a same color pair.

- Select **Only for objects bigger than** to force the trap expert to apply one identical action to occurrences of one color pair belonging to small objects, and to allow different settings for the occurrences belonging to the bigger objects.

## 6.77. Expand Dynamic VDP Data

### Concept

This task creates PDF/VT files from a database containing variable data, using a VDP template (VDT file).

This task requires:

- a CSV database as input
- a VDT or a PDF+ template



**Note:** You can successfully cancel this task when it is already processing.

### Task Settings

#### Database File:

- **Encoding:** Choose the correct character encoding to ensure accurate interpretation of the database entries.



**Note:** The default encoding is **UTF-8**. This is also the recommended encoding.

- **Field Separator:** Let the task **Detect automatically** or choose **,** (**Comma**), **;** (**Semicolon**), **Space** or **Tab**.

- **Empty lines:** Choose what needs to happen with empty lines in the input CSV file. Only lines ending with CR, LF or CR LF can be detected as an empty line (it is possible to mix different line endings in a single file). All empty lines at the end of the file are skipped.
- **Field Names:** Field names map data chunks from the database entry to its corresponding VDP template items. Choose from:
  - **From CSV File:** When selected, the task will extract **Field Names** from the first record of the CSV file by default.



**Attention: Field Names** can only contain the following characters: lower- or upper-case ASCII letters ("a-z, A-Z"), digits ("0-9") or underscore ("\_").

- **From Header File:** When selected, define a **Header File** that contains the **Field Names**. Such a file
  - should contain a single line specifying the **Field Names**
  - should have a **Field Name** corresponding to each column in the CSV file.
  - and the CSV file must use the same delimiter and encoding.
- **Header File:** (described above). Browse or use SmartNames to define this file.

**Dynamic VDP:**

- **Template:** Define the VDP template file that contains artwork and the placeholders necessary to generate the task output. This template can be a
  - a VDT file created in Adobe Illustrator and exported using the Dynamic VDP DeskPack plug-in
  - a PDF file created in ArtPro+ as a Variable Data Template.
- **Image Path:** If the database file has image references, provide the **Image path**.
- **Fonts Path:** The VDP template that was created in ArtPro+ or DeskPack can be one that uses many fonts.
  - **Not using this option** means that all the fonts used in VDP text objects have to be installed on the AE server to allow their expansion. Even fonts used in a single VDP job have to be installed on the AE server, as it is typically unclear when to uninstall a font because you are not sure when another job will need it.
  - **Using this option** means that the fonts used in VDP text objects do not have to be installed on the AE server because you here define where the VDP expansion task can find them. When any non-standard fonts are used in VDP text or barcodes, someone needs to copy the used font files to the here indicated path. This path depends on the workflow that you prefer:
    - You can always add new fonts used in VDP text to a **central** place to have them available for all VDP jobs.
    - You can choose to keep them **local**, within the Job Folder. Each VDP job can so contain not just the VDP template and database but also a subfolder with the fonts needed by this template. This approach may be more work when the same special font is used in many VDP jobs, but does make it easier to for example archive or exchange this job.



**Note:** Fonts used in the static part of the design are not needed because the PDF file already contains that required subset.



**Note:** When a font is both available in the here defined folder and is also installed on the AE server, then the fonts indicated here in this ticket will have priority over any fonts already present centrally.

**Output:**

- **Create separate background file:**

Select this to save the static background from a VDP one-up as a separate file. The actual expanded data then do not contain this background.

This feature only has a minimal (positive or negative) effect on the speed of the expansion or the step & repeat, but was designed to significantly speed up the RIP'ing.

- When **not selected** (default): The task generates a PDF/VT with both static (background) data and variable data on each page. The background is stored only once in each PDF/VT file and reused on all pages via 'form' objects, thus making the file small.



**Note:** As defined in the PDF/VT standard, the reused background is correctly tagged by GTS\_ tags. These tags together with other conditions like support of blending nodes are a requirement for the RIP to support the reusing of backgrounds.

- When **selected**: The task creates one extra single page file containing the background data (any data that was below the first VDP object). The VDP content itself is output as usual into files named `file-00001`, `file-01001`, etc. Any static objects between or above VDP objects also become part of the 'variable' data pages.



**Important:**

- This option should only be used when both the VDP expansion and the step & repeat is done by Automation Engine. When this option was selected, the VDP expansion output cannot be used *directly* for any 3rd party software or for a DFE.
- When the output of this task is used in Step & Repeat tasks (excl. the 'Classic' ones), then its structure is automatically recognized. However, the structure of the output from these step & repeat tasks will be different: All the backgrounds will be combined into a single 'form' object and it will be reused on all sheets below all variable one-ups. In most cases this will reduce RIP'ing time.
- In case you work with a DFE, this means that you can not use the output of VDP expansion with separated background for creation of a DFE Print Job. However, when you perform the VDP expansion *and* the step & repeat in AE, then the result is a standard multi-page PDF file that can be used in DFE.



**Attention:** Should we always use this option? No!

While this option is an improvement for some jobs, it could also make the RIP'ing time worse for other jobs. This is why we advise to check its effect on your typical jobs to find what works best for you. We do have these general guidelines:

- The best results can be seen in combinations of small VDP objects and a complex background.
- When the background is missing or simple, or when the VDP objects are too complex or large, then it is better to not use this option.



**Note:** The RIP system configuration can also effect the result. When selected, the RIP has to keep a much larger object (background for a complete sheet) in its cache memory. Therefore, the amount of RAM available for each 'RIP worker' can be the deciding factor whether it actually improves speed.

## 6.78. Export ArtiosCAD Design Info

---

### What?

This task exports an ArtiosCAD design to an XML file. This XML file is then interpreted by an external system.

This task is also typically launched by that external system.

### More Info

This task is set up by an Esko Solution Architect. Learn about Esko Solution Services on <https://www.esko.com/support/solution-services>.

For more information, search for online articles on this topic in the [Esko Knowledge Base](#).

## 6.79. Export ArtiosCAD Print Item as ARD File

---

### What?

This task exports a Print Item as a new ARD design from an ARD design that has multiple print items.

### More Info

This task is set up by an Esko Solution Architect. Learn about Esko Solution Services on <https://www.esko.com/support/solution-services>.

For more information, search for online articles on this topic in the [Esko Knowledge Base](#).

## 6.80. Export ArtPro to Normalized PDF File (Classic)

This task converts an ArtPro file to a Normalized PDF file.

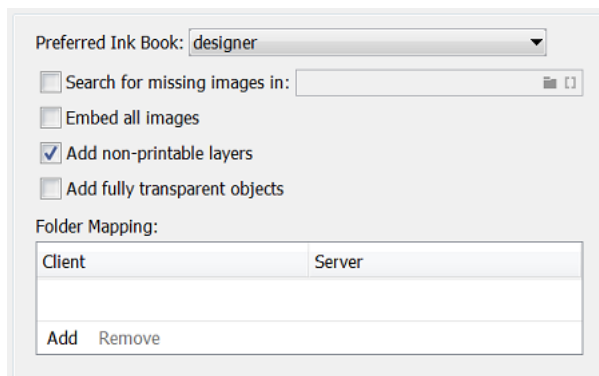

- **Preferred Ink Book:** Select the ink book that the task should check when processing inks that are not in the *predefined* ink books (such as the 'process' and PANTONE ink books).

For each ink in the ArtPro file, the task will:

- First look in the predefined ink books (such as the 'process' and PANTONE ink books),
- then in the **Preferred Ink Book** that was selected here.
- If it doesn't find the ink in the **Preferred Ink Book**, it will be saved as an unregistered ink.
- If the ink is not present in the color database, it will also be saved as an unregistered ink.
- **Search for missing images in:** When the ArtPro file contains links to images that the task can't access, you can copy those images to a folder within an Automation Engine Container, and browse to that folder here.
- **Embed all images:** Embeds all images referenced in the ArtPro document into the PDF file.
- **Add non-printable layers:** When selected, layers set to "non printing" are also exported into the PDF file.
- **Add fully transparent objects:** When selected, objects that are completely transparent will be included in the PDF file.
- **Folder Mapping:** When the ArtPro file contains links to images that reside on a Mac OS-based file server, you can mount the drive of the Mac OS server on the Automation Engine server and use this 'Folder Mapping' table to keep the links to the images working in the output file.

To map folders from the ArtPro file to the Normalized PDF file:

1. Click **Add**.
2. In the **Client** column, type the drive name on the Mac OS system.
3. In the **Server** column, type the drive letter that is used to mount the Mac OS drive on the Automation Engine server.

For example, in our ArtPro file, the path to an externally linked image is:

`Intel_Mac:images:image1.`

We mount the `Intel_Mac` drive of the Mac OS file server on our Windows-based Automation Engine system, using the drive letter `G:\`.

The task will find the images when you map the folders `Intel_Mac` to `G:\`.

## 6.81. Export Gang Run Layouts (Classic)

---

This task is described in the chapter *Gang Run Printing*. Find a direct link [here](#).

## 6.82. Export IMP File to GRI File (Classic)

---

Learn more in the dedicated document on "Commercial Print (Imposition) workflows in Automation Engine". Find it next to the "Complete Manual" of version AE **18.1** on <https://www.esko.com/en/Support/Product?id=Automation%20Engine&ver=18.1>.

## 6.83. Export IMP File to JDF Layout (Classic)

---

Learn more in the dedicated document on "Commercial Print (Imposition) workflows in Automation Engine". Find it next to the "Complete Manual" of version AE **18.1** on <https://www.esko.com/en/Support/Product?id=Automation%20Engine&ver=18.1>.

## 6.84. Export IMP File to JDF Post-Press (Classic)

---

Learn more in the dedicated document on "Commercial Print (Imposition) workflows in Automation Engine". Find it next to the "Complete Manual" of version AE **18.1** on <https://www.esko.com/en/Support/Product?id=Automation%20Engine&ver=18.1>.

## 6.85. Export IMP File to PDF File (Classic)

---

Learn more in the dedicated document on "Commercial Print (Imposition) workflows in Automation Engine". Find it next to the "Complete Manual" of version AE **18.1** on <https://www.esko.com/en/Support/Product?id=Automation%20Engine&ver=18.1>.

## 6.86. Export IMP File to PDF File Chain (Classic)

---

Learn more in the dedicated document on "Commercial Print (Imposition) workflows in Automation Engine". Find it next to the "Complete Manual" of version AE **18.1** on <https://www.esko.com/en/Support/Product?id=Automation%20Engine&ver=18.1>.



## 6.87. Export IMP File to PostScript File (Classic)

---

Learn more in the dedicated document on "Commercial Print (Imposition) workflows in Automation Engine". Find it next to the "Complete Manual" of version AE **18.1** on <https://www.esko.com/en/Support/Product?id=Automation%20Engine&ver=18.1>.

## 6.88. Export Imposition to JDF Layout (Classic)

---

Learn more in the dedicated document on "Commercial Print (Imposition) workflows in Automation Engine". Find it next to the "Complete Manual" of version AE **18.1** on <https://www.esko.com/en/Support/Product?id=Automation%20Engine&ver=18.1>.

## 6.89. Export Imposition to PDF File (Classic)

---

Learn more in the dedicated document on "Commercial Print (Imposition) workflows in Automation Engine". Find it next to the "Complete Manual" of version AE **18.1** on <https://www.esko.com/en/Support/Product?id=Automation%20Engine&ver=18.1>.

## 6.90. Export PDF Info

---

### Concept

This task creates a preview image (JPEG or PNG) and/or an XML file describing the metadata of the task's input file(s).

By default, this task uses the graphic kernel of ArtPro+. This means it supports native PDF (+) files as input. However it also supports input of normalized PDF files.



**Note:** The task *Create PAF / JPG / XML (LinkEdge)(Classic)* also exports preview data and metadata but uses the BRIX graphic kernel. This means it supports normalized PDF files by default. But also here, PDF(+) native input files are supported but those will first be normalized internally. Note that this task extracts the XMP metadata that is already present on board the normalized PDF file.



**Note:** The ink coverage information is calculated in the same way as it is done in ArtPro+ (i.e. how the Marks calculate it there).

### Preview tab

- **Create preview image:** An image is made of the trim box of the PDF (RGB, 8 bits per channel). It is color managed, this means that BGCMS ink books are used to render the separations. The document color profile is taken into account when calculating the RGB values.

- **Content:** Choose which page box decides the content of the preview file: the trim or the media box. In case the media box does not completely cover the trim box, then just the size of the media box is taken.
- **Set:** Choose what is more important: the resolution of the image, or its dimensions?
  - **Resolution:**
    - **Resolution:** Specify a resolution in `ppi` (default) or `ppcm` or `ppmm`. The field also accepts some calculations, for example `72 px / 25.4 mm`.
    - **Limit:** Alternatively, limit the resolution by specifying the *maximum* number of rows (**Width**) or columns in the image (**Height**).



**Note:** This mode is useful to control the size of the image when seen on a screen (based on the resolution setting of that screen).

- **Dimensions:** Alternatively, you can set the number of rows (**Image Width**) or columns (**Image Height**) that the image must have. Be aware that this can result in white areas (pixels) left/right or top/bottom of the image.



**Note:** This mode is useful to control the size of the image on any output (paper).

- **Image Format:** JPEG or PNG files, both RGB.
- **Compression:** When creating JPEG files, select the level of compression. Higher compression results in smaller files but less precise data.
- **Anti-aliasing:** An extra filter that enhances the quality of the image.
  - **No Anti-aliasing:** The image is rendered at the requested resolution, no anti-alias filter is applied.
  - **Normal Quality:** This level of anti-alias means that the file is rendered at double resolution and each cluster of 4 (2 x 2) pixels is averaged into 1 output pixel.
  - **Best Quality:** This level means the file is rendered at 4x the resolution and each cluster of 16 (4 x 4) pixels is averaged into 1 output pixel.
- **Page Range:** One preview file per selected PDF Page. The name of the image will get a suffix to indicate the page number ('\_p1', '\_p2', ...).

To specify a page selection, the typical syntax is valid. Some examples:

- To select pages 3 to 8: type `3-8`
- To select pages 1 to 5: type `1-5` or type `-5`
- To select pages 6 till the last page, type `6-`
- To select pages 2 to 5 and also 12 to 19, type `2-5, 12-19`



**Note:** For a multi page file, the ink coverage is not calculated per page but in ranges of pages. When the PDF has more than 100 pages, ink coverage is not calculated.

### XML tab

- **Create XML report:** When selected, the task exports an XML file that describes the input file. Such metadata is typically to be interpreted by other systems (DAM, MIS, ERP, inspection, etc.)

Learn all about the latest format of this metadata description in [below page](#).



**Note:** Learn about different types of metadata in Esko's file formats in the chapter "PDF formats and their Metadata", in the section on [PDF+ in Automation Engine](#) on page 52.

- **XML structure:**
  - **PDF+:** This exports the Metadata+ on board the PDF(+) file. Metadata+ is an XML serialization of an extended version of [ISO 21812-1](#).
  - **XMP:** This Esko classic form of XMP metadata was used for Esko Normalized files. This is also the type of XMP that was exported with the task [Create PAF / JPG / XML \(LinkEdge\)\(Classic\)](#) on page 277.



**Note:** Learn more in [Metadata in PDF+ \(vs. XMP in Normalized PDF\)](#) on page 55.

## 6.90.1. XML specification of Metadata+

### Main components in Metadata+

Metadata+ is an XML serialization of an extended version of [ISO 21812-1](#).

- The document root node is DPartRoot.
- The document root contains a single **Assembly DPart Node**.
  - The DPM/Root/Metadata element contains admin data like project, job and customer data.
  - The DPM/Root/AssemblingIntent defines which components are included in this assembly.
  - The DPM/Root/Production/RunList contains the URL of the PDF that was used to derive these metadata.
  - The DPart child nodes of this node can be Assembly DPart Nodes or Component DPart Nodes.



**Note:** In the current implementation, Esko editors do not yet use this node, but this task does.

- A **Component DPart Node** describes a physical entity.
  - The Root/@Amount node defines how many components are used in the assembly from which it is referred.
  - The Root/Intent/MediaIntent defines the substrate of this component.
  - The Root/Production/Resource/ShapeDef defines the shape of the produced component. This can be a reference to a CAD file.
  - The DPart child nodes of a Component DPart Node are Side DPart Nodes.
- A **Side DPart Node** describes a printed surface of a component.
  - The Root/Intent/@eg:Side attribute defines the side.
  - The Root/@Start and Root/@End attributes define start and end page in the PDF for the graphics of this side of the component.
  - The Root/Production/ColorantControl element defines the colorants that are used on the side of the component and their order. Root/Production/Resource/Color elements define the characteristics of these colorants.
  - The Root/Production/Resource/eg:InkCoverage element defines ink coverage data.

Diagram

Packaging Document Metadata

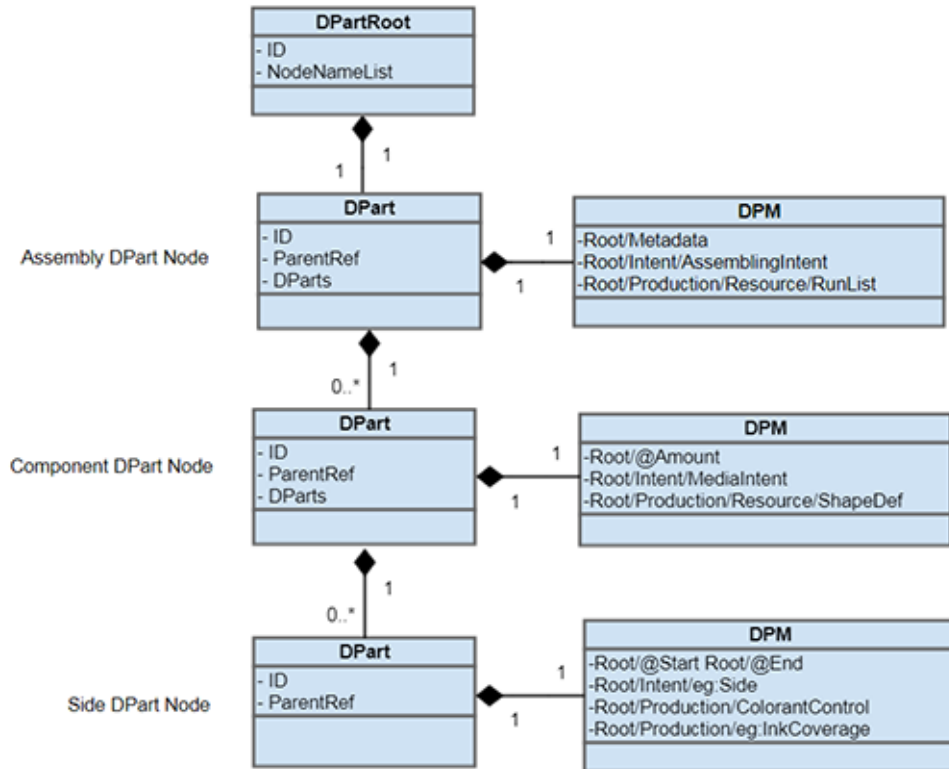

The above text and diagram reflect the most general case. In simpler cases the structure can be condensed, for example the *Assembly DPart Node* can be omitted for a single part product.

Example

```

<?xml version="1.0" encoding="UTF-8" standalone="no" ?>
<DPartRoot ID="0001" NodeNameList="Root DocPart" xmlns:cip4="http://www.CIP4.org/JDFSchema_2_0" xmlns:eg="http://www.esko.com/EskoXJDF">

  <DPart DParts="0003" ID="0002" ParentRef="0001">
    <DPM>
      <cip4:Root cip4:ExternalID="1-079055-01">
        <cip4:Production>
          <cip4:Resource>
            <cip4:RunList cip4:NPage="1">
              <cip4:FileSpec URL="file://eskw190090/ExampleJobContainer/Products/4000/1-079055-01/1-079055-01.pdf" eg:SmartID="y4t7s"/>
            </cip4:RunList>
          </cip4:Resource>
        </cip4:Production>
        <cip4:Metadata cip4:DescriptiveName="Wintercollection 2019"
cip4:JobID="Wintercollection 2019" cip4:ProjectID="Bubbles Winter 2019">
          <cip4:Sender cip4:ContactTypes="Customer">
            <cip4:Company cip4:CompanyID="4000" cip4:OrganizationName="Bubbles bvba"/>
          </cip4:Sender>
        </cip4:Metadata>
      </cip4:Root>
    </DPM>
  </DPart>

  <DPart End="0" ID="0003" ParentRef="0002" Start="0">
  
```

```

<DPM>
  <cip4:Root>
    <cip4:Intent cip4:ProductType="ProductPart"/>
    <cip4:Production>
      <cip4:Resource>
        <cip4:Color cip4:ActualColorName="white screen" cip4:ColorBook="designer"
cip4:ColorBookEntry="white screen" cip4:ColorType="Opaque" cip4:Lab="100.000000
-128.000000 -128.000000" cip4:Part="S1" cip4:PrintingTechnology="Unknown"/>
      </cip4:Resource>
      <cip4:Resource>
        <cip4:Color cip4:ActualColorName="Cyan" cip4:ColorType="Normal"
cip4:Lab="64.146841 -18.246758 -33.574261" cip4:Part="C1"
cip4:PrintingTechnology="Unknown"/>
      </cip4:Resource>
      <cip4:Resource>
        <cip4:Color cip4:ActualColorName="Magenta" cip4:ColorType="Normal"
cip4:Lab="47.603270 71.332470 1.368770" cip4:Part="M1"
cip4:PrintingTechnology="Unknown"/>
      </cip4:Resource>
      <cip4:Resource>
        <cip4:Color cip4:ActualColorName="Yellow" cip4:ColorType="Normal"
cip4:Lab="90.036958 -13.226733 83.807520" cip4:Part="Y1"
cip4:PrintingTechnology="Unknown"/>
      </cip4:Resource>
      <cip4:Resource>
        <cip4:Color cip4:ActualColorName="PANTONE Dark Blue C"
cip4:ColorBook="PANTONE GoeGuide Coated" cip4:ColorBookEntry="PANTONE Dark Blue C"
cip4:ColorType="Normal" cip4:Lab="20.856725 29.076063 -68.454417" cip4:Part="S2"
cip4:PrintingTechnology="Unknown"/>
      </cip4:Resource>
      <cip4:Resource>
        <cip4:Color cip4:ActualColorName="die cut" cip4:ColorBook="Visualizer
Standard Finishes" cip4:ColorBookEntry="die cut" cip4:ColorType="Normal"
cip4:Lab="47.999999 66.000004 46.000005" cip4:Part="S3"
cip4:PrintingTechnology="Unknown"/>
      </cip4:Resource>
      <cip4:Resource>
        <cip4:ColorantControl ColorantOrder="S1 C1 M1 Y1 S2 S3" ColorantParams="S1 C1
M1 Y1 S2 S3"/>
      </cip4:Resource>
      <cip4:Resource>
        <cip4:ShapeDef CutBox="0.0 0.0 461.026770 237.599980">
          <cip4:FlleSpec URL="shower gel medium.DAE"/>
        </cip4:ShapeDef>
      </cip4:Resource>
      <cip4:Resource>
        <eg:InkCoverage>
          <eg:InkCov cip4:Part="S1" eg:Mm2="53.315034" eg:Pct="0.391088"/>
          <eg:InkCov cip4:Part="C1" eg:Mm2="2458.345685" eg:Pct="18.032998"/>
          <eg:InkCov cip4:Part="M1" eg:Mm2="543.030848" eg:Pct="3.983359"/>
          <eg:InkCov cip4:Part="Y1" eg:Mm2="588.284119" eg:Pct="4.315311"/>
          <eg:InkCov cip4:Part="S2" eg:Mm2="551.882149" eg:Pct="4.048287"/>
          <eg:InkCov cip4:Part="S3" eg:Mm2="334.312166" eg:Pct="2.452320"/>
        </eg:InkCoverage>
      </cip4:Resource>
      <cip4:Resource>
        <cip4:RunList cip4:SourceMediaBox="0.000000 0.000000 294.292914 517.719685"
cip4:SourceTrimBox="28.346457 28.346457 265.946457 489.373229"/>
      </cip4:Resource>
    </cip4:Production>
  </cip4:Root>
</DPM>
</DPart>
</DPartRoot>
    
```

### The component DPart node

The component DPart node contains:

XML node	Value	Example
DPart/DPM/Root/Production/Resource/RunList/FileSpec/@URL  DPart/DPM/Root/Production/Resource/RunList/FileSpec/@eg:SmartID	[ <u>URL of Input</u> ] the complete URL of the PDF file  [ <u>SmartID</u> ] the smartID of the PDF file	<cip4:FileSpec URL="file://AEserver01/ExaCont/Prods/40/79055/1-079055-01.pdf" eg:SmartID="12bxg5d"/>
DPart/DPM/Root/Production/Resource/RunList/@NPage	The number of pages in the document	<cip4:RunList cip4:NPage="1">
DPart/DPM/Root/Metadata/Sender/Company/@CompanyID  DPart/DPM/Root/Metadata/Sender/Company/@OrganizationName	[ <u>Job Customer ID</u> ] [ <u>Job Customer Name</u> ]	<cip4:Company cip4:CompanyID="4000" cip4:OrganizationName="Bubbles bvba"/>
DPart/DPM/Root/Metadata/@DescriptiveName  DPart/DPM/Root/Metadata/@JobID  DPart/DPM/Root/Metadata/@ProjectID	[ <u>Job Name</u> ] [ <u>Order ID</u> ] [ <u>Project ID</u> ]	<cip4:Metadata cip4:DescriptiveName="Wintercollection 2019" cip4:JobID="Wintercollection 2019" cip4:ProjectID="Bubbles Winter 2019">
DPart/DPM/Root/ExternalID	[ <u>Product Part Name</u> ] (in case the PDF is a product)	<cip4:Root cip4:ExternalID="1-079055-01">
DPart/@DParts	List of side DPart node ID's	<DPart DParts="0003" ID="0002" ParentRef="0001">

**The Side DPart node**

The Side DPart node contains:









XML node	Value	Example
DPart/@ID  DPart/@Start  DPart/@End	This node's ID  the start page of the PDF described by this node  the end page of the PDF described by this node	<DPart End="0" ID="0003" ParentRef="0002" Start="0">
DPart/DPM/Root/Production/Resource/ColorantControl/@ColorantParams  DPart/DPM/Root/Production/Resource/ColorantControl/@ColorantOrder	defines all the colorant identifiers  the ordering of the colorant identifiers	<cip4:ColorantControl ColorantOrder="S1 C1 M1 Y1 S2 S3 S4" ColorantParams="S1 C1 M1 Y1 S2 S3 S4"/>

XML node	Value	Example
DPart/DPM/Root/Production/Resource/Color/@ActualColorName DPart/DPM/Root/Production/Resource/Color/@Part DPart/DPM/Root/Production/Resource/Color/@ColorBook DPart/DPM/Root/Production/Resource/Color/@ColorType DPart/DPM/Root/Production/Resource/Color/@ColorBookEntry DPart/DPM/Root/Production/Resource/Color/@PrintingTechnology DPart/DPM/Root/Production/Resource/Color/@Lab	Actual name of the separation in the PDF  The colorant identifier  the ink book of this separation  Any of Normal, Opaque, Technical, Varnish  Name of the separation in the ink book  The printing method of the separation  The Lab values of the separation	<pre>&lt;cip4:Color cip4:ActualColorName="PANTONE Dark Blue C" cip4:ColorBook="PANTONE GoeGuide Coated" cip4:ColorBookEntry="PANTONE Dark Blue C" cip4:ColorType="Normal" cip4:Lab="20.856725 29.076063 -68.454417" cip4:Part="S2" cip4:PrintingTechnology="Unknown"/&gt;</pre>
DPart/DPM/Root/Production/Resource/eg:InkCoverage/eg:InkCov/@Part DPart/DPM/Root/Production/Resource/eg:InkCoverage/eg:InkCov/@eg:Pct DPart/DPM/Root/Production/Resource/eg:InkCoverage/eg:InkCov/@eg:Mm2	The colorant identifier  The inkcoverage as % of the trim box area  The ink coverage value in square mm	<pre>&lt;eg:InkCov cip4:Part="C1" eg:Pct="50.0" eg:Mm2="100.0"/&gt;</pre>
DPart/DPM/Root/Production/Resource/Runlist/SourceMediaBox DPart/DPM/Root/Production/Resource/Runlist/SourceMediaBox	The bounding box of the media box (in pt)  The bounding of the trim box (relative to the mediabo)	<pre>&lt;cip4:RunList cip4:SourceMediaBox="0.000000 0.000000 246.103914 469.530707" cip4:SourceTrimBox="4.251969 4.251969 241.851946 465.278738"/&gt;</pre>
DPart/DPM/Root/Production/Resource/ShapeDef/FileSpec/@URL DPart/DPM/Root/Production/Resource/ShapeDef/@CutBox	The relative URL of the structural design object  The bounding box of the (non-rotated) structural design object	<pre>&lt;cip4:ShapeDef CutBox="0.0 0.0 461.026770 237.599980"&gt; &lt;cip4:FileSpec URL="shower gel medium.DAE"/&gt; &lt;/cip4:ShapeDef&gt;</pre>
DPart/DPM/Root/Production/Resource/ScreenSets	The screen sets present in the input file.  It can contain one or more of these attributes:	See an example in below section.

XML node	Value	Example
	<ul style="list-style-type: none"> <li>• <b>Colorant</b> (name of the separation). A value "Default" is not seen as a name but as containing values for any here not mentioned separations. This metadata is shown in ArtPro+ but not in an AE file Info dialog.</li> <li>• <b>Angle</b></li> <li>• <b>Frequency</b></li> <li>• <b>DotName</b> (optional) - typical for PDF+</li> <li>• <b>SpotFunction</b> (optional) - typical for native PDF (not PDF+)                             <p>DotName or Spot function could be present but not both of them in the same entry.</p> </li> <li>• <b>DGC</b> (optional) - typical for PDF+</li> <li>• <b>PressSync</b> (optional) - typical for PDF+                             <p>DGC or PressSync could be present but not both of them in the same entry.</p> </li> </ul>	 <p><b>Note:</b></p> <ul style="list-style-type: none"> <li>• In ArtPro+ you can see screening parameters for a separation with an empty name ; this is the Colorant <code>Default</code> value. In Automation Engine, a file's <b>Info</b> panel does not show such <code>Default</code> screening for unnamed separations. However, this info will also be present in the exported XML of this metadata.</li> <li>• In PDF+ and in Normalized PDF the name of a custom dot shape will be mentioned. In old native PDF files however, these will be called 'Spot functions'. In ArtPro+ and in an AE file Info dialog, the 'spot functions' are displayed as an empty name, however the here exported XML will also contain this complete information.</li> </ul>

### Example of Screen Sets

Screen Sets: Units: ▾ mm | Resolution: ▾ pp

Default							
#	Color	Separation Name	Ruling	Angle	Dot Shape	DGC	%
1		Cyan	120.00	15.00	C	PressSync A	48
2		Magenta	120.00	75.00	C	PressSync B	51
3		Yellow	120.00	0.00	C	PressSync A	50
4		PANTONE 258 C	120.00	45.00	C	PressSync A	50
Test 2							
#	Color	Separation Name	Ruling	Angle	Dot Shape	DGC	%
1		Cyan	120.00	15.00	E	hp3500gl_c	
2		Magenta	120.00	75.00	E	hp3500gl_m	
3		Yellow	120.00	0.00	E		
4		PANTONE 258 C	120.00	45.00	E	EG_example_groo...	



This info will result in this XML:

```
<eg:ScreenSets>
  <eg:ScreenSet Name="Default">
    <eg:Screening Angle="45.000000" Colorant="Default" DotName="C" Frequency="120.000000"
    PressSync="A50"/>
    <eg:Screening Angle="45.000000" Colorant="PANTONE 258 C" DotName="C"
    Frequency="120.000000" PressSync="A50"/>
    <eg:Screening Angle="15.000000" Colorant="Cyan" DotName="C" Frequency="120.000000"
    PressSync="A48"/>
    <eg:Screening Angle="75.000000" Colorant="Magenta" DotName="C" Frequency="120.000000"
    PressSync="B51"/>
    <eg:Screening Angle="0.000000" Colorant="Yellow" DotName="C" Frequency="120.000000"
    PressSync="A50"/>
  </eg:ScreenSet>
  <eg:ScreenSet Name="Test 2">
    <eg:Screening Angle="45.000000" Colorant="Default" DotName="E"
    Frequency="120.000000"/>
    <eg:Screening Angle="45.000000" Colorant="PANTONE 258 C"
    DGC="EG_example_groovy_curve" DotName="E" Frequency="120.000000"/>
    <eg:Screening Angle="15.000000" Colorant="Cyan" DGC="hp3500gl_c" DotName="E"
    Frequency="120.000000"/>
    <eg:Screening Angle="75.000000" Colorant="Magenta" DGC="hp3500gl_m" DotName="E"
    Frequency="120.000000"/>
    <eg:Screening Angle="0.000000" Colorant="Yellow" DotName="E" Frequency="120.000000"/>
  </eg:ScreenSet>
</eg:ScreenSets>
```

### More Examples

On [AE's documentation page](#), download the ZIP file "**Export PDF Info task - Example metadata XML files**" to get these example XML files:

- The example shown on this page: EXA\_1-079055-01.xml
- A duplex printed folding carton: FC\_dpm.xml
- A duo-label: LabML\_dpm.xml
- A display: Display\_dpm.xml

## 6.91. Export Picture List

### Concept

This task exports a list of linked placed art for each page of the input file. It contains the file's name, position and page box. This list is a text file with an extension .PICL

Use case: A 3rd party wants a simple list of the files that were placed on a layout. It typically uses it to check if all required variants were or will be placed on a sheet.



**Note:** This functionality will mainly be used interactively in ArtPro+.

### Task Settings

- **Export Pages:** You can choose to limit the list of placed art to be from only a selection of pages.

The classic syntax is valid ; some examples:

- To select pages 3 to 8: type 3-8
- To select pages 1 to 5: type 1-5 or type -5

- To select pages 6 till the last page, type 6-
- To select pages 2 to 5 and also 12 to 19, type 2-5, 12-19



**Note:** The task will fail when there is no placed art on a selected page.

**Sample**

```
ArtPro Picture File V1.0
units mm
size 689.85 754.24

1.pdf 0 0 153.31 188.56 0 76.58 94.43 TrimBox
2.pdf 0 377.12 153.31 188.56 0 76.58 94.43 TrimBox
3.pdf 153.3 0 153.3 188.56 0 76.58 94.43 TrimBox
4.pdf 153.3 377.12 153.3 188.56 0 76.45 94.31 TrimBox
5.pdf 306.61 0 153.3 188.56 0 76.58 94.44 TrimBox
6.pdf 306.61 377.12 153.3 188.56 0 76.58 94.44 TrimBox
7.pdf 459.91 0 153.3 188.56 0 68.96 94.08 TrimBox
8.pdf 459.91 377.12 153.3 188.56 0 76.61 94.43 TrimBox
9.pdf 76.65 188.56 153.3 188.56 180 76.72 94.13 TrimBox
10.pdf 76.65 565.68 153.3 188.56 180 76.72 94.13 TrimBox
11.pdf 229.95 188.56 153.3 188.56 180 76.84 94.25 TrimBox
12.pdf 229.95 565.68 153.3 188.56 180 76.85 94.25 TrimBox
13.pdf 383.25 188.56 153.3 188.56 180 76.72 94.13 TrimBox
14.pdf 383.25 565.68 153.3 188.56 180 84.99 94.33 TrimBox
15.pdf 536.55 188.56 153.3 188.56 180 76.85 94.25 TrimBox
16.pdf 536.55 565.68 153.3 188.56 180 71.03 81.41 TrimBox
```

## 6.92. Export Step & Repeat to JDF Layout (Classic)

This task exports a Step & Repeat layout to a "JDF Layout" file that contains references to the station, mask and mark files which are written in a subfolder.



**Note:** This JDF Layout file is compatible with the ICS-LayCrlmp.

This is an alternative way to send final layouts to a 3th party workflow system (instead of sending it Step & Repeat PDF files).

Task settings:

- You can choose the **JDF Version:** 1.2 or 1.3.
- **Create MIME file:** Select this to get the JDF and the referenced PDF files all together in a MIME packed file.



**Important:** This task uses the Brix graphics engine. Learn about the identical task type that uses the ArtPro+ NDLE engine in [Export Step & Repeat to JDF Layout](#) on page 324.

## 6.93. Export Step & Repeat to JDF Layout

This task exports a Step & Repeat layout to a "JDF Layout" file that contains references to the stations, mask and mark files which are written in a subfolder.



**Note:** This JDF Layout file is compatible with the ICS-LayCrImp.

This is an alternative way to send final layouts to a 3th party workflow system (instead of sending it Step & Repeat PDF files).

This task ticket offers no settings.

- When the task is launched in a job context, the JobID in the JDF file is taken from the job's Order ID.
- The JobPartID in the JDF file is a combo of the JobID and the output file name specified in the ticket. When no JDF output file name was specified, the JobID is combined with the input file name.

## 6.94. Export to 3D (Classic)

### Concept

This task creates 3D files which you can view in 3D viewers. The input file needs to be a Normalized PDF or PDFSTA (Station file) that links to a structural design file: an ArtiosCAD ARD file or a Collada file (DAE or ZAE).

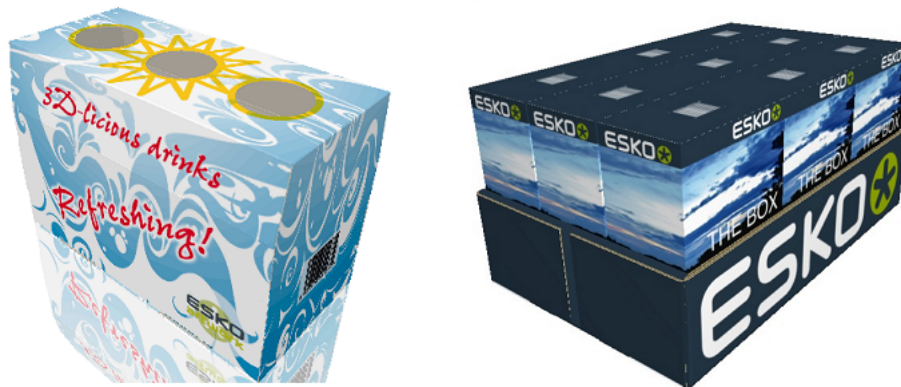

**Important:** When you work with PDF+ files, we advise to use the task [Export to 3D](#) on page 328.

### About Structural Design Files

A structural design file (2D and 3D) contains all the cut and crease lines for a specific shape. It can also contain folding angles that define how it should be folded into its final shape. A structural design file does not contain the graphics, only the definition of the shape.

The link between a graphics design and its structural design (shape) can be done in an editor (ArtPro, PackEdge or Adobe Illustrator (using the Esko [Data Exchange plug-ins](#)). ARD files can also be linked to a graphic using the [Load Structural File task \(Classic\)](#).

3D data can be created by using one of these structural design file formats:

- ARD files, created in **ArtiosCAD** or **Studio Toolkit for Boxes**

- .ZAE files, created in **Studio Toolkit for Flexibles**.
- .DAE or .ZAE **Collada** files. These can have a **printable part** (an Esko extension to the Collada format). Such Collada files can be created in **Studio Designer**, **Studio Toolkit for Shrink Sleeves**, **Studio Toolkit for Labels** and **ArtiosCAD**.

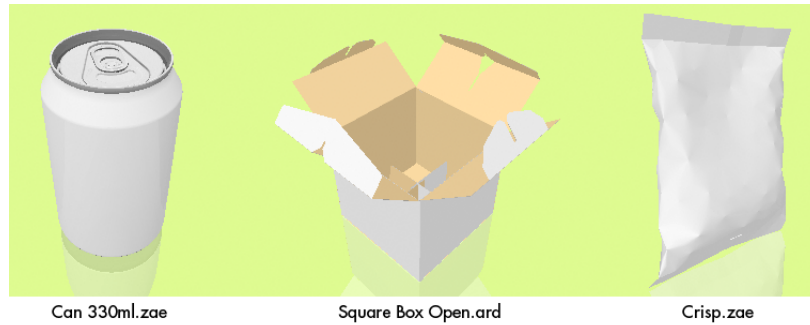

### 6.94.1. Export to 3D Settings

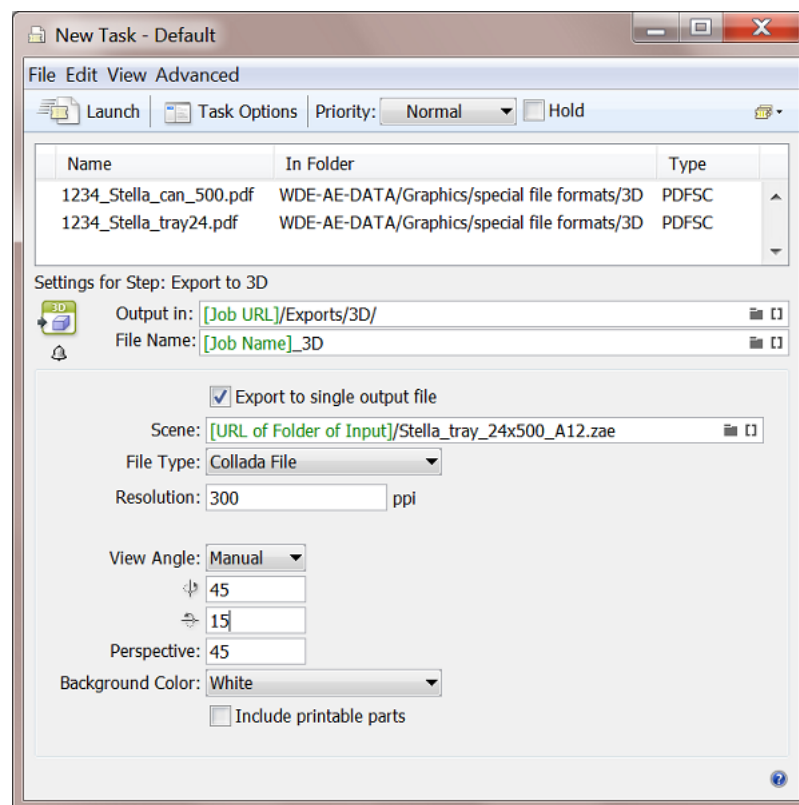

- **Export to single output file:**
  - When **not selected**, an output file is produced for each page and for each input file that contains a link to a structural design file.

- When the input file is a multi-page file, the page number will be added as suffix to the output file name.
- When the output file matches the input file name (e.g. when exporting to PDF and no output name is specified), the output file name will get "\_3D" as suffix.
- When **selected**, one output file is produced.
  - When a scene is selected, the input files/pages matching the parts of the scene will be used in the output.
  - When no scene is selected,
    - and the input files/pages contain different printable parts of 1 Collada file, then the Collada file is used as scene and the input files/pages matching the printable parts of Collada file will be used in the output.
    - and the first input file does not refer to a Collada file, then only the first input file is used in the output and the other input files/pages will be ignored.
- **Scene:** A scene allows to combine multiple task input files into a combined shape. These input files could be
  - multiple input PDFs containing the same structural design,
  - one input PDF with three pages referring to one part of a scene,
  - multiple input single page PDFs referring to one part of a scene,



**Note:** A scene is a .ZAE file that you can create in Esko ArtiosCAD and Studio Toolkit. It contains links to multiple .ARD or Collada files.

- Output **File Type:** Choose from these file formats:
  - **Tiff Image.** A 2D image.
  - **PDF File with 3D Design:** Enables to view the 3D in Adobe Reader or Acrobat Professional (version 8.0.1 or later).
  - **U3D File:** A common exchange format for 3D objects that you can place in Acrobat Professional (version 8.0.1 or higher).
  - **Collada file:** A common exchange format for 3D objects that can also be viewed in Esko **Studio Viewer** and in Esko **WebCenter's** integrated 3D Viewer.

### Settings per File Type:

- **Exporting to Collada**
  - Choose **Collada File** as **File Type** and specify the **Resolution** of the image(s).
  - Define the **View Angle** from which the object should be rendered. You can either specify them manually here or inherit the angles from the scene file (using the angle that the file was saved with in Illustrator, Studio or PackEdge).
  - Adapt the **Perspective**. A high value has the effect of a camera with a wide angle lens, close to the object. A low value has the effect of a camera with a zoom lens, further away from the object. The default is 45 degrees.



**Note:** The object will always fit completely inside the exported image.

- Choose **White** or **Black** as **Background Color**.
- **Include Printable Parts**: Deselect this to make a 3D that only serves to be viewed. Select it to allow the receiver to edit it, for example to place variant graphics.
- **Exporting to TIFF**
  - Choose **Tiff Image** as **File Type** and specify its **Resolution**.
  - Define the **Width / Height** of the image. The TIFF image will always be square and will contain the whole shape.
  - Define the **View Angle** and **Perspective**.
  - Choose a **Background Color: White, Black** or **Transparent** (useful when placing the image in others).
- **Exporting to PDF with 3D Design**
  - Choose **PDF File with 3D Design** as **File Type** and define its **Width, Height** and **Resolution**.
  - **Show Footer**: Select it to add a (custom) **Footer Text**.
  - Define the **View Angle** and **Perspective**.
  - Choose **White** or **Black** as **Background Color**.
- **Exporting to U3D File**
  - Choose **U3D File** as **File Type** and define its **Resolution**.
  - Define the **View Angle** and **Perspective**.
  - Choose **White** or **Black** as **Background Color**.

## 6.95. Export to 3D

---

### Concept

From PDF+ file(s) that contain a link to structural design (ARD, ZAE, DAE), this task creates 3D file(s) in the requested format.

When a 'scene' is defined, input files are combined into one output file.



### Settings

- **Scene:** A scene allows to combine multiple task input files into a combined shape. These input files could be:
  - multiple PDF files referring to different printable parts of the same structural design file.
  - one PDF file with multiple pages each referring to a different printable part of the same structural design file (or scene).

An example of a structural design file that has 3 printable parts:

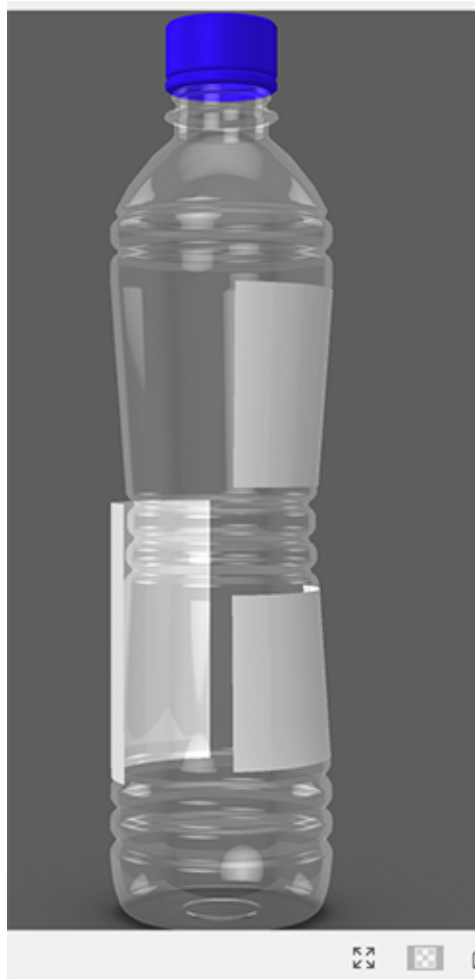

A scene can be an .ARD (ArtiosCAD) file, a .ZAE (Collada Zipped Exchange Archive) file or a .DAE (Collada XML) file. Learn more in [this KB article](#) .

- **Export Type:** Choose from these file formats:
  - **Tiff, PNG or JPEG:** A 2D image.
  - **PDF File with 3D Design:** Enables to view the 3D in Adobe Reader or Acrobat Professional (version 8.0.1 or later).  
An optional footer text can be added to the PDF.
  - **Collada file:** A ZAE file, a common exchange format for 3D objects that can also be viewed in various Esko viewer tools.
  - **U3D File:** A common exchange format for 3D objects that you can place in a PDF (using Acrobat Professional version 8.0.1 or higher).
  - **Binary glTF File Image.** A GLB file (GL Transmission Format Binary), the binary format version of a *glTF* (JSON) file.
- All other settings depend on the selected output type:



### Settings per Export Type

- **Exporting to a 2D Image (TIFF, PNG, JPEG)**

- Define the **Image Width / Height**. The 2D image will always be square and will contain the whole shape.
- Specify its **Resolution**. For JPEG, also define the image **Quality**.
- Define the **View Angle** and **Perspective**.
- (Tiff and PNG only) Choose if you want a **Transparent** background (useful when placing the image in others).
- Define the angle of the View **Heading, Tilt** and **Perspective**.



**Note:** Perspective: A high value has the effect of a camera with a wide angle lens, close to the object. A low value has the effect of a camera with a zoom lens, further away from the object. The default is 45 degrees. The object will always fit completely inside the exported image.

- Define if you want a **Floor Shadow**.
- Choose a **Background Color: White, Black**

- **Exporting to PDF with 3D Design**

- Define the PDF's page **Width** and **Height**.
- If you want, add a text to serve as a **Page Footer**.
- Define the **Artwork Resolution**.
- Choose if you want to **Avoid Z-fighting Artefacts**. In cases where it is unclear which panel is on top (resulting in flickering graphics), a calculated choice will be made, cutting out the underlying part and giving the top part carte blanche.
- Define the angle of the View **Heading, Tilt** and **Perspective**.
- Choose **White** or **Black** as **Background Color**.

- **Exporting to a Collada file**

- Define the **Artwork Resolution**.
- Define if you want to **Avoid Texture Slicing**. When requesting a high resolution, it is possible that at least one part will have to be sliced into multiple pieces. This is not real a problem when the 3D file is only intended for viewing. However, when the 3D file has to be annotated or edited, it is recommended to select this option. It will lower the resolution ... WDE Q: SO IS THIS I WHAT THIS OPTIONS DOES? PLEASE EXPLAIN HOW THIS OPTION WORKS (AVOIDS SLICING).
- Define the angle of the View **Heading, Tilt** and **Perspective**.
- Choose **White** or **Black** as **Background Color**.

- **Exporting to U3D File**

- Define its **Artwork Resolution**.
- Define if you want to **Avoid Z-Fighting Artefacts**.
- Define the angle of the View **Heading, Tilt** and **Perspective**.
- **Exporting to Binary glTF File File**
  - Define its **Artwork Resolution**.
  - Define if you want to **Avoid Texture Slicing**.
  - Define if you want to **Avoid Z-Fighting Artefacts**.
  - Define if you want to **Optimize for Microsoft Office** applications. This is required to see transparency in non-printable parts in these applications. When disabled, advanced glTF features are used that in some viewers might result in more realistic looking files.

## 6.96. Export to ArtPro File (Classic)

---

This task exports a Normalized PDF file to an ArtPro file.

Choose the ArtPro **Version**:

- an **ArtPro 10.x/9.x/8.x** file
- an **ArtPro 7.5/7.0** file. These do not contain version-specific information or blend modes (the file will be flattened).

**Copy linked files next to output file**: Select this to copy the linked images next to the created ArtPro file.

## 6.97. Export to EPS/DCS File (Classic)

---

The task settings are spread over five tabs:

- [Output](#)
- **Color Management**: These settings are identical in the [Color Management tab of the PostScript Export task](#).
- **Rasterize**: These settings are identical in the [Rasterize tab of the PostScript Export task](#).
- **Compression**: These settings are identical in the [Compression tab of the PostScript Export task](#).
- **Advanced**: These settings are identical in the [Advanced tab of the PostScript Export task](#).

### 6.97.1. Output

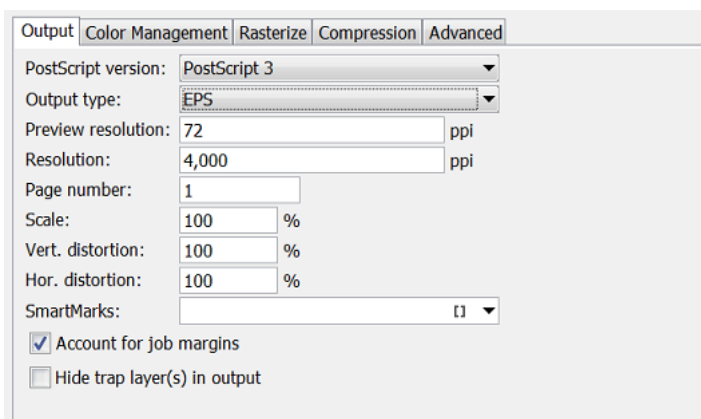

- **PostScript version:** Choose between 2 or 3.
- **Output type:**
  - **EPS.** This creates an EPS file with an RGB preview. Select PostScript 3 and deselect color management (in the tab 'Color management') to create a 'deviceN' EPS. In all other cases a CMYK composite EPS will be created.
  - **Single DCS file.** This creates an EPS DCS file with multiple separations. The RGB preview of the DCS file is used when placing the EPS DCS file. In addition, a **grayscale composite** or color CMYK preview can be added for composite printing.
  - **Multiple DCS file.** This creates a master EPS DCS file referring to multiple separations (one file per ink). The names of the 'Multiple DCS' files consist of the name of the original EPS DCS file followed by `_C`, `_M`, `_Y`, `_K` or `_1`, `_2`, `_3`, ... (for all non-process inks). The files have an extension `.x`.  
The RGB preview of the Master DCS file is used when placing the EPS DCS file. In addition, a **grayscale composite** or color CMYK preview can be added for composite printing.
- **Preview Resolution:** This is the resolution of the RGB preview used when placing the EPS DCS file. A higher value will produce a finer, more detailed preview but will also increase the files size of the EPS DCS. The default and minimal value is 72 ppi.
- **Resolution:** If you do not know where the EPS will be placed, you best request a high resolution file (the default is 4.000 ppi.). Mind that, the higher the resolution, the bigger the size of the EPS file will be.
- **Page number:** Select a page if you only want to export that page of your input file.
- **Scale:** Allows you to scale the file, for example at 50%.
- **Vert. and Hor. Distortion:** Use one of these fields if you want a different scaling in either direction (max 90%).
- **SmartMarks:** If you want to add any, select or define a set.
- **Account for job margins:** Select this to also include the data between the borders (Trim Box) and the margins (Media Box).
- **Hide trap layer(s) in output:** Select this if you do not want those objects in the output file.

## 6.98. Export to Gravure using HELL Job Ticket

### Concept

This task is similar to the more generic task [Export to Unscreened Separations](#) on page 351, but it will use the settings that the HELL front end operator already defined in the HELL output tickets for that job.



**Important:** When printing units were assigned in the input file, then only those separations with assigned printing units can be exported. When no printing units were used, all selected separations will be exported normally.

### Task Settings

- **Job Ticket:** Define the folder that contains the HELL Job Ticket files.
- **Anti-Aliasing:** Select if you want only on the one-up data or on the complete file which then includes the print marks for example.
- **Add Noise:**
- **Task ends in error when linked artwork is not up to date:** Select this as wanted.

## 6.99. Export to Normalized PDF File (Classic)

This task converts a GRS file to a Normalized PDF file. GRS is a legacy Esko file format.

Version: Normalized PDF (Esko 7) ▼

**External References**  
External references are exported together with the input file

- Write local external references to the output folder and other external references to their original folder
- Write all external references to the output folder
- Write all external references to their original folder

When converting again:

- Reconvert if recently updated
- Use previous conversions
- Always reconvert

**Embed External Images**  
Embed Images:

- All images (1-bit, 8-bit and native)
- Images with uncompressed data size smaller than 640 kB
- None

Copy Other Images to Output Folder:

- Only images which are close to the input file
- All images
- None

Fail when fonts are not found

Fail when external references are not found

---

i 'Close to the input file' means: in a subfolder or a neighboring folder

### External References

External references have to be converted. Choose your preference:

- **Write local external references to the output folder and other external references to their original folder.**

When exporting, external references in subfolders or neighboring folders will be written to the output folder. External references in for example central folders will be written in their original folder.

- **Write all external references to the output folder.**
- **Write all external references to their original folder.**

**When converting again**, you can choose to:

- **Reconvert if recently updated:** Only updated references will be reconverted, all other conversions will be used as they were.
- **Use previous conversions:** The existing conversions will be used. Potential updates will not be considered.
- **Always reconvert:** All external references will be converted at all times.

### Embed External Images

Referenced external files in GRS format can be converted to referenced files in Normalized PDF file format. Define which images you want to have converted:

1. **All images.**
2. **Images with uncompressed data size smaller than 640 kB** (as specified in [Configure > Processing Preferences > Embedded Images](#)). This option is identical to the option in the [Images tab](#) of the [Normalize PostScript / PDF / Illustrator 8.0 File](#) task.
3. **None.**

### Copy Other Images to Output Folder

Indicate what should happen with the external images. You can have them copied to the output folder, or you can choose to leave them in their original folder.

### Fail when fonts are not found

When the fonts used in the file are not found the task will fail, when the toggle is not selected, the task will end with a warning.

### Fail when external references are not found

The task will fail when not all external files were found.

## 6.100. Export to Normalized PDF File (Embed All)(Classic)

---

You can use this task to create a self-contained version of a Normalized PDF file with references or of a PDFPLA file.

This task embeds all the external references, images and fonts into the Normalized PDF output file.



**Note:** The [Export to Normalized PDF task](#) only allows to embed *images*.

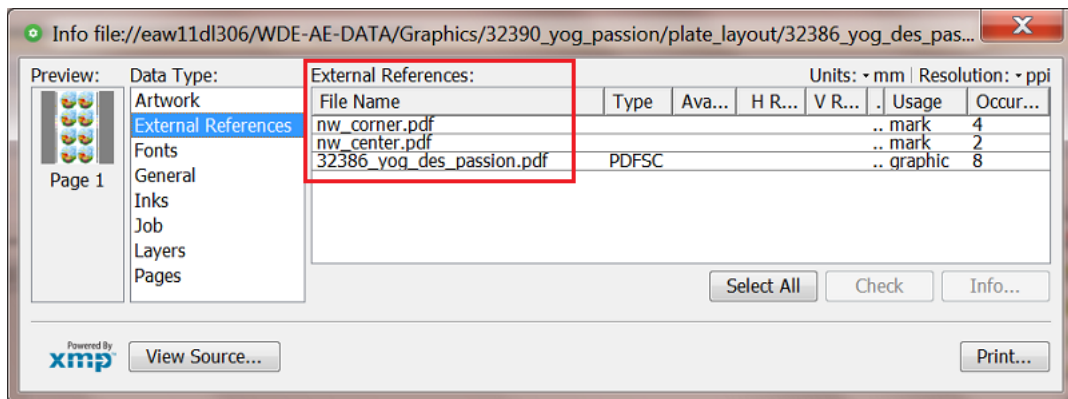

## 6.101. Export to PDF File (Classic)

### Concept

This task exports Normalized (layout) PDFs to a native PDF. This task is often used to make a PDF of a specific version or with specific color settings to match the device it will be used for. This task is also often used to make a self-contained version of a PDF with external references, which makes it easier to exchange this data to someone else.

### Factory settings

The **Default** ticket of this task offers **Factory settings**. Selecting one is a quick way to define the many ticket parameters. After selecting such a 'preset', you can still change any parameters.

- **PDF for data interchange.** Use to send this graphic data out.
  - **(PDF 1.3):** Offers high compatibility but slow and less editable. Use this if it needs to be opened in Acrobat 4 or lower, or if a RIP requires this format.
  - **(PDF 1.4):** For interchange with recent applications, well editable. For example Acrobat 5 and higher.
  - **(PDF 1.5):** For interchange with recent applications, well editable. For example Acrobat 6 and higher.
  - **(PDF 1.6):** For interchange with recent applications, well editable. For example Acrobat 7 and higher.
- **PDF/X:** PDF/X is a standardized subset of PDF designed specifically for reliable interchange of prepress data. It is used for RIP'ing and imposition.
  - **(PDF/X-1a:2001 (ISO/DIS 15930-1)):** PDF/X-1a ensures complete data exchange using CMYK and spot color data.
  - **(PDF/X-3:2003 (ISO/DIS 15930-3)):** PDF/X-3 ensures complete data exchange suitable for coloured managed workflows.

- **PDF for Illustrator CS2 or higher:** For a PDF file meant to be edited in Adobe Illustrator CS2 or higher.



**Attention:** This version improves the editability in Adobe Illustrator, but does not guarantee full editability.

- **PDF for viewing/proofing**
  - **CMYK Composite:** Useful when using hard copy proofers, or when the result doesn't have to be editable or when the result is used for soft-proofing. It is not useful to serve as final output.
  - **RGB:** Useful for soft-proofing ; a smaller file, and faster to generate.
  - **DeviceN:** Data interchange file for proofing/viewing (all separations present). Adobe Acrobat Reader 7.0 or later is required to view the overprint settings correctly.



**Note:** Even though, for **trapping** reasons, Acrobat 7 Professional and higher allow to define an ink as Opaque ("Ink Manager"), this has no influence on the PDF preview.

### Detailed settings

The many ticket parameters are divided over seven tabs:

- [Output](#) on page 337
- [Device](#) on page 340
- [Color Management](#) on page 340
- **Inks**, similar to the [tab Inks/Separations in the "Export to PostScript" task](#).
- **Rasterize**, similar to the [tab Rasterize in the "Export to PostScript" task](#).
- [Compression](#) on page 342
- [Advanced](#) on page 343.

## 6.101.1. Output

The screenshot shows the 'Output' tab of a software interface. At the top, there are seven tabs: 'Output', 'Device', 'Color Management', 'Inks', 'Rasterize', 'Compression', and 'Advanced'. The 'Output' tab is active. Below the tabs, there are several settings:

- PDF version:** A dropdown menu set to 'PDF 1.3'.
- Output type:** A dropdown menu set to 'Composite'.
- Emulsion up:** A dropdown menu set to 'Right Reading'.
- Image:** A dropdown menu set to 'Positive'.
- Distortion:** Two input fields, both set to '100 %'.
- Scale:** An input field set to '100 %'.
- SmartMarks:** A dropdown menu set to '[]'.
- Account for job margins:** A checked checkbox.
- Hide trap layer(s) in output:** An unchecked checkbox.
- Keep notes:** An unchecked checkbox.
- Page Range:** A section with two radio buttons: 'All' (selected) and 'Pages: 1'.

Below the 'Page Range' section, there is a text box with the instruction: 'Enter page number and/or page ranges separated by commas. For example: 1,3,5-16'.

- **PDF Version:**
  - **PDF 1.6:** The Acrobat 7 file format.
  - **PDF 1.5:** The Acrobat 6 file format.
  - **PDF 1.4:** The Acrobat 5 file format.
  - **PDF 1.3:** The Acrobat 4 file format.
  - **PDF for Illustrator:** Select this if the generated PDF 1.4 file will be opened in Adobe Illustrator CS2 or higher. Because Adobe Illustrator only supports an (undocumented) subset of PDF 1.4 features, some objects and/or color-spaces will be split up, transformed and/or pre-ripped in order to correctly represent them in Illustrator.
  - **PDF/X-1a:2001 (ISO/DIS 15930-1)** and **PDF/X-3:2003 (ISO/DIS 15930-3)**. Learn more about these versions [here](#).



**Note:** You can find an (old) white paper about using PDF/X-4 on [this link](#).

- **Password security:** Learn more in [Password Security](#) on page 338.
- **Output type**
  - **Composite:** Select this to create a composite file which, if no color management is used, produces a 'DeviceN' PDF for data interchange. DeviceN means that its colors can be combinations of the standard CMYK process colors and/or spot colors. This guarantees perfectly separable PDF files which can also be proofed on a composite PostScript 3 device. Such a PDF file will both proof and separate correctly. Color management for spot color objects must then be handled by the device.
  - **Separated:** Select this to create a PDF with multiple pages, one page per ink.
    - **Emulsion Up:** Select **Right Reading** (= emulsion up) or **Wrong Reading** (= emulsion down).
    - **Image:** Select **Positive** or **Negative** print mode.
  - **Vert. and Hor. Distortion:** Use one of these fields if you want a different scaling in either direction (max 90%).
  - **Scale:** Allows you to scale the file, for example at 50% to get a smaller MB size when E-mailing the PDF.
  - **SmartMarks:** Add SmartMarks if you want, for example to add the ink coverage on a proof PDF.
  - **Account for job margins:** Select this to also include the data between the borders (Trim Box) and the margins (Media Box).
  - **Hide trap layer(s) in output:** Select this if you do not want those objects in the output file.
  - **Page Range:** When your input file has multiple pages, define here if you want **All** or a selection of these pages in your output PDF file.

## Password Security



**Note:** The options in this dialog depend on the PDF version that you chose in the [Output tab of the 'Export to PDF' task](#).



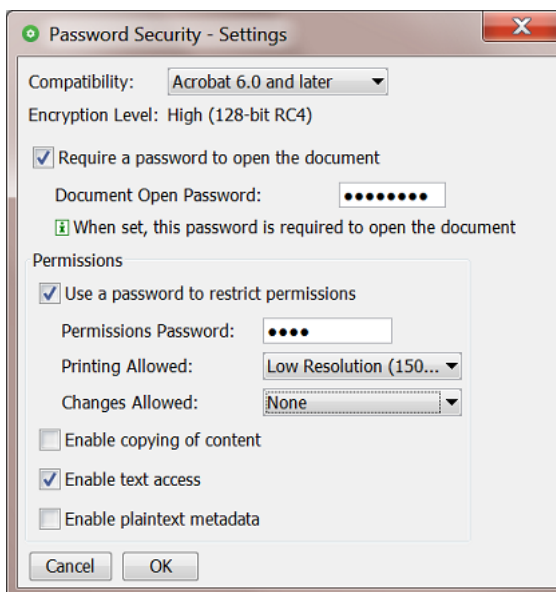

- **Compatibility:** The security features depends on the Acrobat version that you want to output. Your choice defines the **Encryption level**.
- **Require a password to open the document:** If this is what you want, enter a password. Communicate this password to the people that you allow to open this file.
- **Permissions** (some options depend on the selected **Compatibility**):
  - **Use a password to restrict permissions:** If you want to use any of the below options, enter a specific **Permissions Password** and communicate it to the right people.
  - **Printing Allowed:** Select **None** if no-one is allowed to print this file. Select a **Resolution** if the receiver may print it at that level of quality.
  - **Changes allowed:**
    - Select **None** to prevent users from making any changes, not even filling in signature or form fields.
    - Select **Inserting, deleting and rotating** to allow such changes, as well as create bookmarks and thumbnail pages.
    - Select **Any except extracting pages** to allow users any changes except extracting pages.
  - Select **Enable copying of content** to allow the user to do this.
  - Select **Enable text Access** to allow visually impaired users to read the file with screen readers. This option does not allow users to copy or extract any contents.

- **Enable plaintext metadata:** This allows searching the file's properties while still protecting its content.

### 6.101.2. Device

You can make a PDF 'device specific' by adding a description of the required **dot gain compensation** curves inside that PDF.



**Attention:** These curves are not calculated, but stored as 'PDF standard transfer curves'. Opening the PDF in Acrobat will not show any difference.

You can create **Dot Gain Compensation** curves (DGC) with Esko Curve Pilot.

- **Single Curve:** Select one DGC curve (.dgc file) that will be applied to all your data.
- **Automatic:** Allows you to select one of these types:
  - A **Screen-Based DGC table** (.scredgc file), to apply dot gain compensation selectively, depending on the dot shape, screen ruling, angles and even **Contone** or **Linework** properties.
  - A **DGC Strategy** (.icpro file), does the same but also offers ink-based dot gain compensation.
  - A **Press sync** file (\*.prsync). These curve values are inserted as a transfer curve in the PDF.



**Note:** You can also apply *both* a single curve and an automatic DGC. This then results in a cumulation of both effects.

### 6.101.3. Color Management

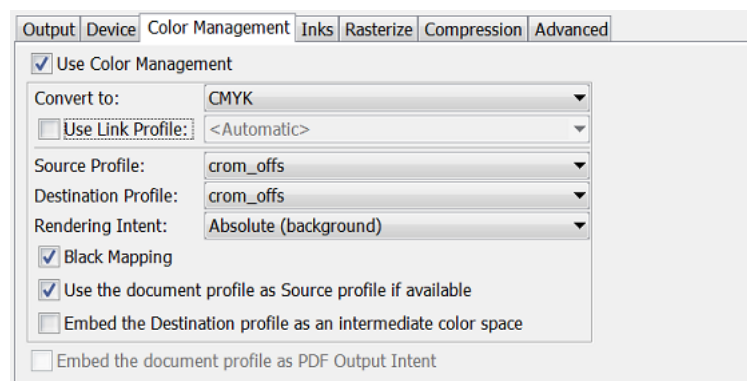

When you choose not to apply any color management when creating the PDF, you can still embed the document's profile (see below).

When creating a *composite PDF*, you can choose to **Use Color Management** with these options:

- **Convert to:** Select to which color space all inks should be converted: **CMYK**, **RGB** or **Gray** values.
- **Use Link Profile:** "Link profiles" describe a transformation from one device-dependent color space to another. This is actually a concatenation of a forward transformation of one profile and a backward transformation of another profile. A link profile takes complete care of the color management, so all other options are then disabled.

- **Source profile:** If any CMYK objects need to be converted, choose a 'source profile'. The list shows all CMYK print profiles in the color database. The source profile defines the target that the destination profile is supposed to match.
- **Destination profile:** Choose a color profile for your destination color space. The list shows all print profiles in the color database. These profiles are either measured in Color Pilot or imported ICC-profiles.
- **Rendering intent**
  - **Relative (no background):** Choose this if you do not want any background simulation. The white point of the source will be mapped on the white point of the destination process. This rendering intent takes into account the ability of the human eye to adapt to the surrounding white.
  - **Absolute (background):** Choose this if you want background simulation and you want an exact color match, including the paper simulation.
  - **Perceptual:** This will result in no background simulation (white of reference color space is mapped on white of destination color space). Choose this when you don't care too much about an exact color match but when want the pictures at least to look nice on your proofer. It will give a visually pleasing result. If the gamut of the source is wider than the proofer, the entire gamut is shrunk so that it fits inside the gamut of the proofer.
  - **Saturation:** Choose this if you care especially about saturated colors. This rendering intent will map saturated colors on saturated colors.
- **Black Mapping:**
  - When selected, the CMY part of the composite colors are converted separately from the black component. As a result, the type of black separation (Skeleton black, UCR, GCR...) is preserved by the conversion. It is still possible that the black percentage changes slightly due to different dot gain in the color profiles.
  - When not selected, the converted CMYK colors are completely re-separated into the black behavior that is built into the destination profile.
- **Use the document profile as Source profile if available:** If a document profile is defined, then that one will be used as a source profile. The one chosen from the above **Source Profile** list will be overruled.
- **Embed the Destination profile as an intermediate color space:**
  - When not selected, the colors in the PDF file are not tagged with an ICC color profile. The document is device dependent and its colors will only be reproduced accurately if the PDF file is output on the device that is specified in the **Destination Profile**. This choice is preferable when you are sure the PDF file will be sent to the device specified in the Destination Profile.
  - When selected, the colors in the PDF file are tagged with an ICC color profile. The document then becomes device independent, and its colors will be reproduced accurately even on devices with a color space different from the one specified in the Destination Profile. In this case, the Destination Profile is an intermediate color space between the Source Profile and the color profile of the device that will eventually process the PDF file. This choice is preferable when the PDF file will be sent to an unknown device.

**Embed the document profile as PDF Output intent:** The output intent is an ICC profile that specifies the intended output device. When selected, the document profile will be saved as the 'PDF Output Intent'. For some PDF flavors (PDF-X/3), an output intent is mandatory and this option is always on.

When no document profile was set explicitly, the default document profile is used instead (`chrom_offs`). When the document profile is a Color Pilot profile, it will first be converted to an ICC profile.

### 6.101.4. Compression

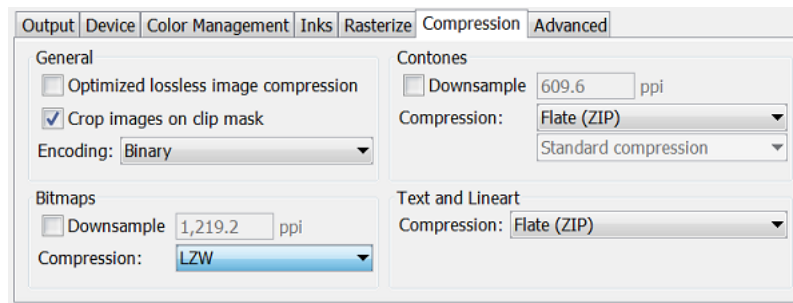

#### General

- **Optimized lossless image compression:** Selecting an overall lossless image compression seldom results in the smallest overall file size. This optimization chooses the smallest lossless compression method for every image separately (JPEG2000, Flate, FlateDiff, LZW, LZWDiff, CCITT3, CCITT4 or Run Length). Its choice depends on the image type and on the compression methods that are allowed for the chosen PDF version.

Selecting this option disables the compression methods for **Bitmaps** and **Contones**. It also sets the encoding to **Binary**, which we advise to keep, otherwise the resulting file will become larger.



**Attention:** Selecting this option considerably slows down this task, so only use it when the size of the file is critical.

- **Crop images on clip mask:** When selected, all information outside the clip mask will not be exported.
- **Encoding**
  - **Binary:** The image data is represented as binary data. This results in compact files. Such files are not editable in a common ASCII editor. Nor can these files be transferred using a communication protocol that relies on control characters in the data stream itself.
  - **Hex:** This forces the output to remain editable with an ASCII editor. It can then also can be transferred using whatever communication protocol is available. The drawback is that hexadecimal image data can take up to twice as much size as binary data.
  - **ASCII 85:** Encodes binary data in an ASCII base-85 representation. This encoding uses nearly all of the printable ASCII characters. The resulting expansion factor is 4:5, making this encoding more efficient than hexadecimal.

#### Bitmaps

- **Downsample:** Referenced images are sub-sampled approximately to the specified value. This reduces the size of the output PDF file. The unit is the one defined in **Edit > Preferences**. Be aware that 1-bit (copydot) images cannot be downsampled.
- **Compression:** Choose the type: **None** or CCITT group 3 / 4, Run Length, LZW (Diff), Flate (ZIP)(Diff).

#### Contones

- **Downsample:** The images referenced in your design are sub-sampled to approximately the specified value. This allows to reduce the size of the generated PDF file. The unit is the one defined in **Edit > Preferences**.
- **Compression:** Choose the type: **None** or LZW (Diff), JPEG(2000), Flate (ZIP)(Diff).  
JPEG compressions allow to specify the quality of the compression..

**Text and Lineart**

- **Compression:** Choose the type: **None** or LZW or Flate (ZIP).

**6.101.5. Advanced**

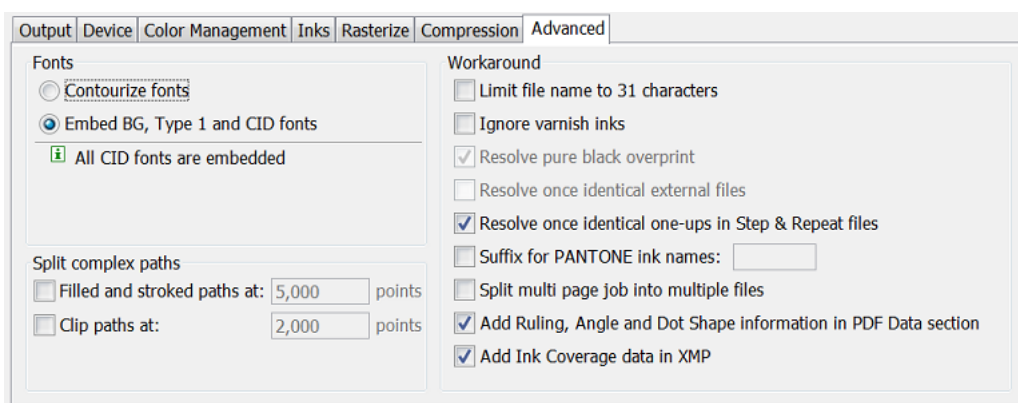

**Fonts**

Choose what to do with the fonts used by your input file's live text:

- **Contourize fonts:** To convert all text into lineart.
- **Embed BG and Type1 and CID fonts**



**Note:** Protected CID fonts will be referenced by name.

**Split Complex Paths:** When a device requires that you create an old version of PDF (1.3), it may also require that you split very complex paths into smaller ones.



**Note:** These are workarounds for typical PostScript level 1 path limitations. Only use these when absolutely necessary.

- **Filled and stroked paths at:** Use this option to split linework with more than x points into several smaller linework parts. This decreases the complexity of the linework. A suitable value for the selected Device type is calculated automatically.
- **Clip paths at:** Use this option to split linework masks for images with more than x points into several smaller linework parts. This decreases the complexity of the masks.

**Workaround**

- **Limit file name to 31 characters:** Select this when the system that will read your output file is limited to 31 characters.
- **Ignore varnish inks:** Select this to exclude varnish inks in your output.

- **Resolve pure black overprint:** Overprints are normally resolved, but by default, pure black is left untouched. Select this option when you also want pure black to be resolved. This option is only available when *Use Color Management* is selected.
- **Resolve once identical external files:** Instead of resolving the complete file and all its external references, identical external files will be resolved only once.
- **Resolve once identical one-ups in Step & Repeat file:** Instead of resolving the complete Step & Repeat file, identical one-ups will be resolved only once.
- **Suffix for PANTONE ink names:** Enter a suffix for PANTONE ink names. The default is 'c'. For example: PANTONE 123 so becomes PANTONE 123 c. Existing suffixes will be replaced by this one.
- **Split multi page job into multiple files:** Every page of a multi page file will be output as a separate PDF file.
- **Add Ruling, Angle and Dot Shape information in PDF Data section:** Select this if the non-Esko RIP that will read the PDF will want to get such screening information from inside the PDF itself. This makes the PDF device-dependant.
- **Add Ink Coverage data in XMP:** Select this to add such data into the PDF's metadata. Mind that calculating the ink coverage will slow down the task.

## 6.102. Export to PostScript File (Classic)

### Factory settings

The **Default** ticket of this task offers **Factory settings**. Selecting one is a quick way to define the many ticket parameters. After selecting such a 'preset', you can still change any parameters.

- **PostScript for press (separated)**
- **PostScript for press (DeviceN composite):** This mode (only supported by PostScript 3 devices) uses the PostScript 'DeviceN' color-space to produce high-fidelity colors. These colors are combinations of the standard CMYK process colorants and/or spot colors, guaranteeing perfectly separable PostScript code that can be proofed on a composite PostScript 3 device.
- **PostScript for viewing / proofing (CMYK composite)**

### 6.102.1. Output

The screenshot shows the 'Output' tab of a software interface with the following settings:

- Device type:** Esko-Graphics CertIn PS 3
- Output type:** Separated
- Emulsion up:** Right Reading
- Image:** Positive
- Distortion:** 100 % (horizontal), 100 % (vertical)
- SmartMarks:** [Empty field]
- Account for job margins
- Hide trap layer(s) in output
- Page Setup:**
  - Paper size:** job
  - Orientation:** None
  - Alignment:** Bottom Left
  - Number of copies:** 1
- Scale & Tile:**
  - Scale: 100 %
  - Fit job on page
  - Shrink oversized jobs to paper size
  - Tile job
  - Overlap: 5 mm
- Page Range:**
  - All
  - Pages: 1
  - Enter page number and/or page ranges separated by commas. For example: 1,3,5-16

**Device type:** The selected device type also determines the PPD that will be used.

**Output type:**

- **Separated:** Select this to generate multiple pages, one for each ink in the file.
- **CMYK Composite:** Select this to generate a composite PostScript file, typically for proofing. All spot colors are converted to CMYK.
- **Composite:** Select this to generate a file for PostScript 3 devices, since they support 'deviceN' color-space to produce high-fidelity colors. These colors are combinations of the standard CMYK process colors and/or spot colors, guaranteeing perfectly separable PostScript code which can also be proofed on a composite PostScript 3 device.

The generated PostScript file will proof correctly and separate correctly. Color management for spot color objects must be handled by the device.

**Emulsion Up:** Select **Right Reading** (= emulsion up) or **Wrong Reading** (= emulsion down).

**Image:** Select **Positive** or **Negative** print mode.

Enter a **Vertical** and/or **Horizontal** distortion in percentages (between 85 and 115 %).

Add **SmartMarks** if you want.

**Account for job margins:** Select this to also include the data between the borders (Trim Box) and the margins (Media Box).

**Hide trap layer(s) in output:** Select this if you do not want those objects in the output file.

**Page Setup**

- Select a **Paper size**. The list is based on the page sizes supported by the selected .PPD.
- **Orientation:** (Disabled when 'Tile job' is selected.)
- **Alignment:** (Disabled when 'Tile job' is selected.)
- Enter the **Number of copies**.

**Scale & Tile**

- Enter a **Scale** factor (percentage).
- **Fit job on page** scales the file so it fits the selected paper size.
- **Shrink oversized jobs to paper size.**
- Select '**Tile job**' to obtain a tiled output if the file is too big to fit on the selected **Paper size**. It then exports a large file to a series of smaller pages (tiles). The user can then cycle through the tiles, and see how many tiles there are.

**Overlap:** The value you enter here is the amount of overlap in all four directions between adjacent tiles.

**Page Range:** When your input file has multiple pages, define here if you want **All** or a selection of these pages in your output PDF file.

## 6.102.2. Device

Most of these options depend on the PPD belonging to the selected [Device Type](#).

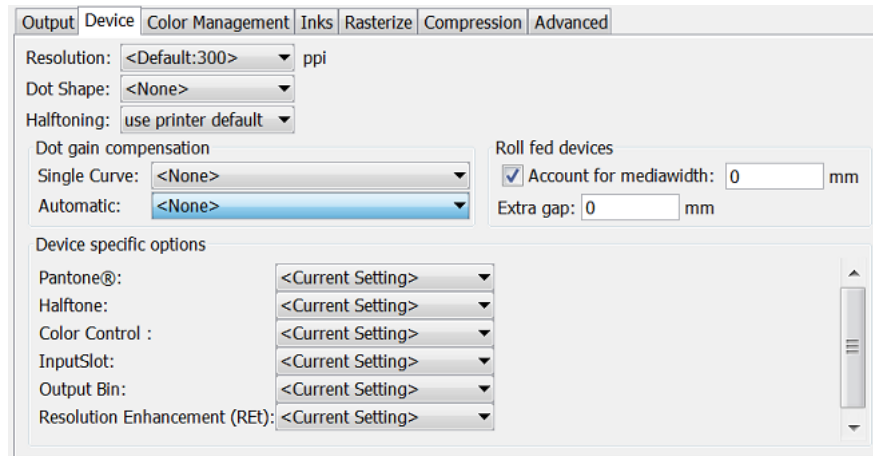

**Resolution:** Select one that fits the purpose of the PostScript file.

**Dot Shape:** Define if you want a specific dot for this file.

**Halftoning:** When the *Output type* is 'CMYK Composite' or 'Composite', you can choose to include screen information (LPI and angle).

- **Use Printer Defaults:** From the output device.
- **Take over from job:** From the input file.
- Some PPDs offer other dot shapes.

**Dot Gain Compensation:** Select a **Single** and/or **Automatic** curves (made in Curve Pilot). This will be added as 'transfer curve'. Learn more [here](#).



**Note:** When a DGC curve is selected, the file will be flattened to ensure that the correct Dot Gain Compensation is applied to transparent objects. This may result in a larger file.

**Roll fed devices:**

- **Account for Media Width** allows the task to find the best printing orientation (when Rotation is set to Auto). For roll-fed devices, mostly film-setters, a media width (film width) can be specified.
- **Extra Gap:** Allows you to specify extra width for the film or paper feed.

**Device specific options:** These depend on the selected PPD. Learn more in the documentation of your output device.

### 6.102.3. Color Management

These options are enabled when you choose the *Device type 'CMYK composite'*.



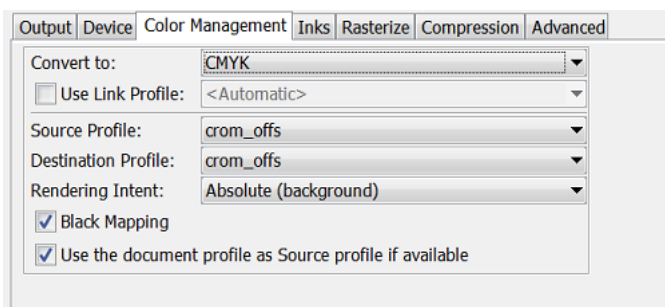

**Convert to:**

- Choose to convert all inks to **CMYK** or **Gray** values.
- **Use Link Profile:** "Link profiles" describe a transformation from one device-dependent color space to another. This is actually a concatenation of a forward transformation of one profile and a backward transformation of another profile. A link profile takes complete care of the color management, so all other options are then disabled.

**Source profile:** If any CMYK objects need to be converted, choose a 'source profile'. The list shows all CMYK print profiles in the color database. The source profile defines the target that the destination profile is supposed to match.

**Destination profile:** Choose a color profile for your destination color space. The list shows all print profiles in the color database. These profiles are either measured in Color Pilot or imported ICC-profiles.

**Rendering intent**

- **Relative (no background):** Choose this if you do not want any background simulation. The white point of the source will be mapped on the white point of the destination process. This rendering intent takes into account the ability of the human eye to adapt to the surrounding white.
- **Absolute (background):** Choose this if you want background simulation and you want an exact color match, including the paper simulation.

**Black Mapping:**

- When selected, the CMY part of the composite colors are converted separately from the black component. As a result, the type of black separation (Skeleton black, UCR, GCR...) is preserved by the conversion. It is still possible that the black percentage changes slightly due to different dot gain in the color profiles.
- When not selected, the converted CMYK colors are completely re-separated into the black behavior that is built into the destination profile.

**Use the document profile as Source profile if available:** If a document profile is defined, then that one will be used as a source profile. The one chosen from the above **Source Profile** list will be overruled.

### 6.102.4. Inks / Separations

The name of this tab depends on the output type you selected in the *Output tab*.

- If you there choose **CMYK Composite** or **Composite**, the **Inks** tab appears:

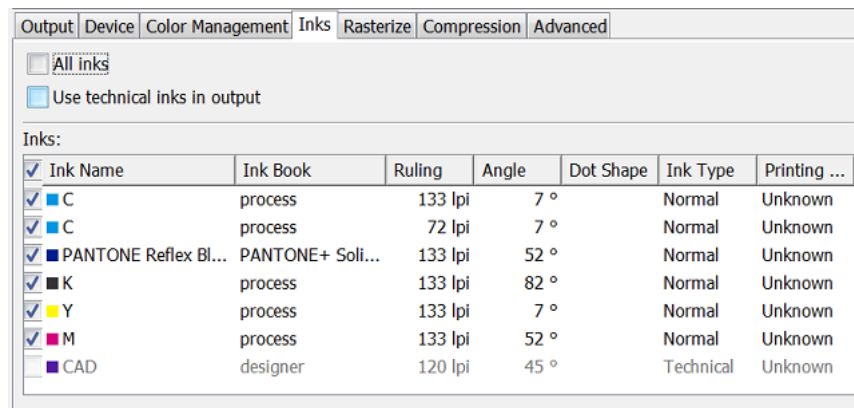

- If you there choose **Separated** output, the **Separations** tab appears.

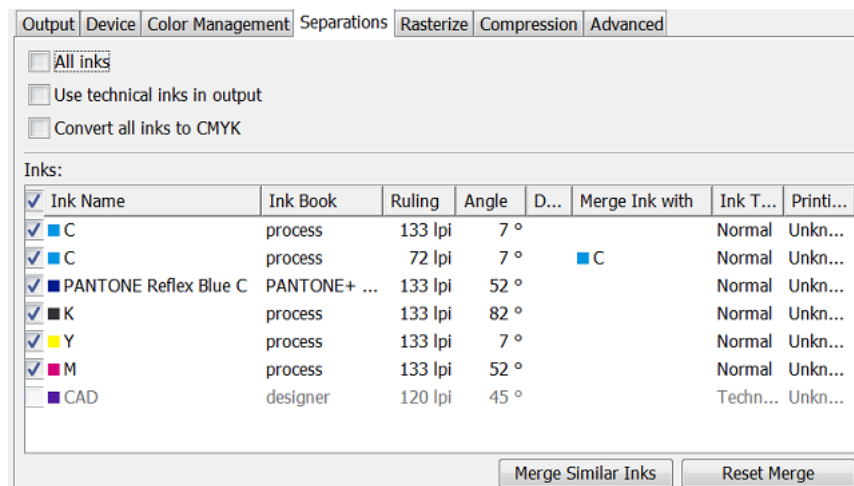

**All Inks:** Deselect this to open an ink-list panel where you can select specific inks.



**Note:** The **Inks** panel only shows the inks that are present in the input file(s) for the first task in your workflow. When no input files are selected yet, you will not be able to “preselect” inks (for example when building workflows in the **Tickets** view).

**Use technical inks in output:** Select this option to also output the (non hidden) technical inks.

**Convert all inks to CMYK:**

In the **Inks** panel, use **Merge Ink With** to output inks on top of each other in the same output file. The ticket proposes this automatically when you have different rulings for 1 ink. You can set this manually by clicking in the **Merge with** column and selecting the ink it has to be merged with.

### 6.102.5. Rasterize

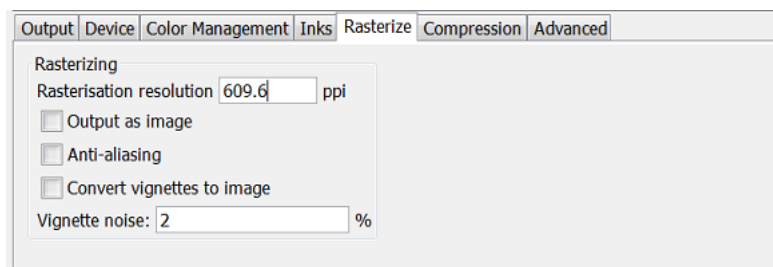

**Rasterisation resolution:** Enter the resolution for the objects that will be 'resolved' (converted to image data).

**Output as image:** Select this to make an image of the input file (with the above set resolution).



**Attention:** All objects in a technical ink will remain linework, they will not be rasterized. This linework is put on top of the rest of the newly generated image. This can have side-effects when mixing technical and non-technical inks (typically when using technical inks for anything else than die cut lines).

**Anti-aliasing:** This smoothens the staircase effect in images generated from line-art objects that were pre-processed. This increases the readability of small text that is converted to image data.

**Convert vignettes to image:** Select this to avoid blends and banding in vignettes when exporting to PostScript. This converts all vignettes to images.

**Vignette noise:** When exporting to PostScript, some (parts of) vignettes will be converted to images. This happens when the vignettes overlap other objects with translucency or when there are overprints between a vignette and other objects.

When 'Convert vignettes to image' is selected, all vignettes are converted to images regardless of any overlap with other objects. Vignettes that are converted to images may have tone jumps in the final result. To reduce this banding effect, noise is applied on the image. Define the amount of noise in this field.

## 6.102.6. Compression

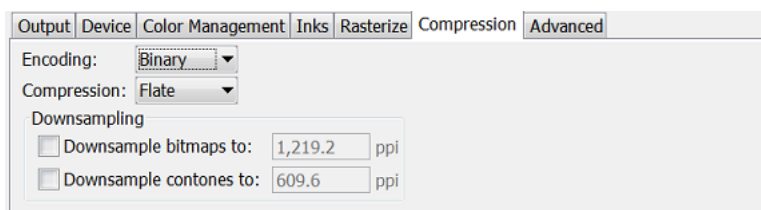

### Encoding:

- **Binary:** The image data is represented as binary data. This results in compact files. Such files are not editable in a common ASCII editor. Nor can these files be transferred using a communication protocol that relies on control characters in the data stream itself.
- **Hex:** This forces the output to remain editable with an ASCII editor. It can then also can be transferred using whatever communication protocol is available. The drawback is that hexadecimal image data can take up to twice as much size as binary data.

- **ASCII 85:** Encodes binary data in an ASCII base-85 representation. This encoding uses nearly all of the printable ASCII characters. The resulting expansion factor is 4:5, making this encoding more efficient than hexadecimal.

**Compression:** Choose **None**, **LZW** or **Flate** (PostScript 3 devices).

**Downsampling:** Use this to downsample the images referenced in the file to (approximately) the specified value. This will result in a smaller PostScript file. It will also be generated faster.

Please be aware that 1-bit copydot images cannot be downsampled.

## 6.102.7. Advanced

### Split Complex Paths

When a device requires that you create an old version of PostScript (level 1), it may also require that you split very complex paths into smaller ones.

- **Filled and stroked paths at:** Use this option to split linework with more than  $x$  points into several smaller linework parts. This decreases the complexity of the linework. A suitable value for the selected Device type is calculated automatically.
- **Clip paths at:** Use this option to split linework masks for images with more than  $x$  points into several smaller linework parts. This decreases the complexity of the masks.

### Workaround

- **Limit file name to 31 characters:** Select this when the system that will read your output file is limited to 31 characters.
- **Ignore varnish inks:** Select this to exclude varnish inks in your output.
- **Resolve pure black overprint:** Overprints are normally resolved, but by default, pure black is left untouched. Select this option when you also want pure black to be resolved.  
This option is only available when you selected 'CMYK composite' as 'Output' tab.
- **Resolve once identical external files:** Instead of resolving the complete file and all its external references, identical external files will be resolved only once.
- **Resolve once identical one-ups in Step & Repeat file:** Instead of resolving the complete Step & Repeat file, identical one-ups will be resolved only once.
- **Suffix for PANTONE ink names:** Enter a suffix for PANTONE ink names. The default is 'C'. For example: PANTONE 123 so becomes PANTONE 123 C. Existing suffixes will be replaced by this one.
- **Suppress hairlines at clips :** Due to the PostScript limitation of the maximum number of points allowed for a path, complex paths will be cut into smaller pieces. When the PostScript file is used for an old PostScript RIP, 'hairlines' can so become visible. To avoid this problem, select this option.
- **Split multi page job into multiple files:** Every page of a multi page file will be output as a separate PS file.
- **Image to paper edge:** This moves the origin of output file to the lower left corner of the paper or film. Select this option to align your file to the edge of the paper or film to use the full area.



**Note:** When exporting to a paper PostScript device, there is typically a border on the output page on which nothing can be imaged. Parts of your design that are located in that border area will be lost.

- **Avoid tabular number problem:** When digits are written as tabular numbers, exporting to some PostScript RIPs may result in bad positioning of the numbers. Select this to avoid that tabular numbers are not correctly placed at the text base line.
- **Disable path clipping:** Select this if you do not want paths to be clipped on the 'borders' (Trim Box) of the file.
- **Map spot color separations to CMYK:** Select this when you export a file containing spot colors to pre-separated PostScript for systems that are limited to separations of process colors (for example a Scitex Brisque workflow).

Spot color separations can only be handled on such systems by mapping them to a specific process separation (not converting, just mapping). Spot colors are then exported as a C, M, Y or K separation according to a simple rotating name principle (C->M->Y->K->C->M...).

Spot colors which are named exactly after process colors remain unchanged.

- **Omit "Process" for CMYK in %% PlateColor comment:** Select this when the file will be sent to a device that does not understand "Process".  
You must select this option when outputting to an Image Setter and when your different separations all have the Angle and Rulings of the K separation (Black).
- **Split separated output into multiple files:** Instead of writing one file containing all separations, the task will write one file per separation.
- **Force Black Overprint:** Select this if you want all 100% black objects to overprint in your PostScript file.

## 6.103. Export to Unscreened Separations

### Concept

This task creates output for gravure printing systems.

The input file is one or more PDF files. A separate task is started per input file.

The output files are unscreened TIFF files, one per separation and page.



**Note:** Objects in non-printing layers will not be exported.



**Important:** When printing units were assigned in the input file, then only those separations with assigned printing units can be exported. When no printing units were used, all selected separations will be exported normally.

### Technology

The way this task generates pixels is the same as **Export Gravure TIFF** function in ArtPro+.



**Note:** Internally, this task runs a [PDF Action List](#) that first selects separations and then exports these to gravure TIFF files.

## Task Settings

- **Processing Steps:**

Any processing steps present in the input file (or in its placed files) are listed here. Deselect those that should not appear in the output.

To be listed here, processing steps have to be in printing layers. When their layer is set to unprintable, they will not show up in this list.

Learn more about processing steps in [Processing Steps - Groups and Types](#) on page 64.

- **Document Inks:** Select how you want to **Select Inks:**

- **All**

- **By using selection criteria:** This is a simplified version of how you select inks in a ticket for Imaging Engine, as described in [Selecting Inks Using Selection Criteria](#) on page 1409.

- **Manually:** This is identical as how you manually select inks in a ticket for Imaging Engine as described in [Selecting Inks Manually](#) on page 1408.

- **Linked Artwork**

- **Force the task to end in error when linked artwork is not up to date.** Select this if that is your preference.

- **Output**

- **File Name:** Use [SmartNames](#) to define the desired names for the TIFF files.



**Note:** When selecting the output format **HELL Compatible TIFF**, the suffix in the name of the TIFF files is a fixed one. Even using SmartNames for a different output name will be overruled.

- **Folder:** Use [SmartNames](#) to define the desired output folder.

- **Output Format:**

- **Separated TIFF:** An unscreened TIFF file per selected ink and page.

- **HELL Compatible TIFF:** This output format ensures that the names of the TIFF files are compatible with the HELL HelioDisk workflow. Also, the TIFF files get a fixed rotation of -90°.

- **Resolution:** You can enter the resolution of the TIFF file in ppi, pppm or ppcm. The value will be recalculated to the default unit as defined in **Edit > Preferences > Units**.

- **Anti-aliasing:** The higher the value the smoother the result will be, but it will take longer to calculate and require more disk space.

- **Apply on all contents in Step & Repeat files:** In a Step & Repeat file, anti-aliasing is by default only applied on the placed one-ups. Select this to apply anti-aliasing on all content of the S&R file itself, so also on the print marks and station numbers.

- **Add Noise:** To avoid banding, add a certain percentage of noise.

- **Write skip areas to files:** When selected, empty areas that are larger than the threshold will be skipped. This information is written next to the TIFF files in a Skip Areas file (.svs). Using this

information, the engraving machine will skip those areas on the cylinder, and so shorten the engraving time.

- **Threshold:** Define how many empty lines such an area should minimally have.

## 6.104. Extract Inks (Classic)

### Concept

This task writes a PDF that only contains the inks that you here decided to keep, by defining their **Name** or on their **Printing Method**.

The resulting PDF will look the same as if you opened the input file in the Automation Engine Viewer and there made the same selection of inks.

This task is typically used to build (parts of) workflows that you only want to execute on specific inks. This is especially useful when the PDF will be output on a hybrid press. For example: a workflow that automatically sends the 'Flexo' inks to a different RIP than the 'Screen' inks.



**Note:** Learn more about such a workflow in the dedicated section about [Hybrid Press Workflow](#) on page 1957.

	+ <input type="checkbox"/> - <input type="checkbox"/>	Ink Book	Ruling	Angle	Dot shape	Type	Printing Method
1		Cyan	process	133.000	7.000	Normal	▸ Flexo
2		PANTONE Reflex Blue C	▸ PANTONE+ Solid Coated	133.000	52.000	▸ Normal	▸ Screen
3		Black	process	133.000	82.000	Normal	▸ Flexo
4		Yellow	process	133.000	7.000	Normal	▸ Flexo
5		Magenta	process	133.000	52.000	Normal	▸ Flexo
6		CAD	▸ <unregistered>	120.000	45.000	▸ Technical	▸ Other

Another example where this task is useful is when you want to generate separate file reports per 'group' of inks.

### Task Settings

You define which inks you want to keep, based on their **Name** or on their **Printing method**.

Click on to select one or multiple printing methods (a list defined in the [Configure tool](#)).

Click **+** if you want to add extra criteria. Click **Alt** and then **...** button to add sub-criteria.

Learn more on how to add such criteria in the page that describes how to make [\(smart\) filters in the Pilot](#).

Some examples:

- Only keeping the inks with the Printing method 'Flexo':

Keep inks that match the following criteria:

Printing method ▾ is Flexo - +

- Only keeping the inks that do *not* have the Printing method 'Flexo':

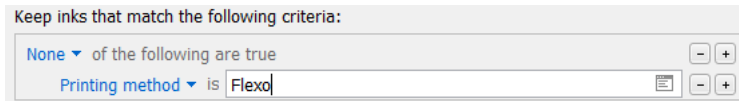

- Keeping the Flexo Pantone inks and/or inks which name contains 'cut' or 'crease' :

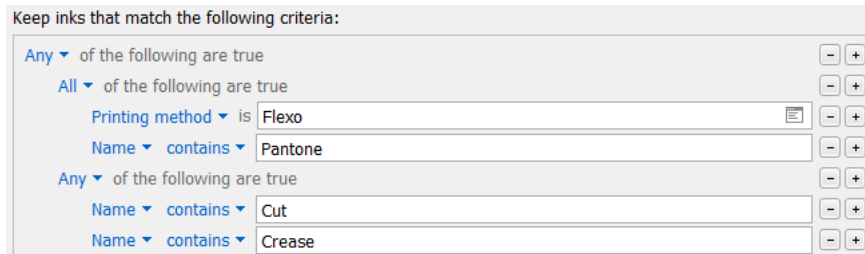

## 6.105. Fill Printing Lanes

---

This task is launched from the browser client of Automation Engine (the Roll-Fed Labels workspace). It is part of the production workflow of a **Production Job**.

Find eLearning modules on the [Esko Blended Learning platform](#).

## 6.106. Fork

---

This Workflow Control is documented in the chapter [Workflows](#). See [Fork and Join](#) on page 837.

## 6.107. Image to Screened Separations

---

This task is documented in the chapter on [Imaging Engine](#). Find a direct link [here](#).

## 6.108. Image to Unscreened Separations

---

This task is documented in the chapter on [Imaging Engine](#). Find a direct link [here](#).

## 6.109. Import Die

---

This task is used to import step & repeat template files into the 'dies' database of Automation Engine (the QuickStart deployment). They there appear in the **Die Gallery**.

Supported input files:



- Resulting in a **'Template Die'**:
  - SRT files, created in Adobe Illustrator with the [DeskPack plugin 'PowerLayout Standalone'](#).
  - PDF files created in [ArtPro+](#).
- Resulting in a **'Numeric Die'**:
  - XML files, when the format is valid (containing the mandatory XML nodes). A numerical die consists of one or more grids. A grid consists of a cell with specific dimensions and a rotation and is repeated a number of times. Find a specification and example below.



**Important:** When importing a die that results in a die database entry with the same name as an existing entry, the existing entry will be overwritten (i.e. the entry is updated).



**Note:** This task has no file output.

### Specification of the Input XML file

- For all tags expecting a distance value, the value should be expressed in **'mm'**.
- The XML file **must contain one or multiple elements** containing the die information. When there are multiple elements, multiple dies will be created / updated.
- The default **name for this root** node is called 'Die'. You can specify the name of the XML element (node or attribute) by:
  - any combination of:
    - a fixed value
    - a SmartName
  - an XPath expression
  - a public parameter.



**Note:**

- When the XML **element name is not an XPath expression** (i.e. not prefixed with 'xpath:'), each element in the XML with local name (i.e. name of the XML node or XML attribute without the optional namespace prefixes) equal to the specified XML element name is used to create or update a die entry in the database.
- When the XML **element name is an XPath expression** or resolves to an XPath expression, all elements selected by evaluating the XPath expression are used to create or update a die entry in the database.

### Parameters defining the die

You can specify the name of the XML element or attribute to use to update a die parameter by:

- any combination of a fixed value and/or a SmartName
- an XPath expression, relative to the element

Table: Main Parameters defining the Die

Element	Name in UI	Usage	Description
<b>Name</b>	<b>Name</b>	Optional	Name of the die. Default name is the name of the input XML file.
<b>VSize</b>	<b>Vertical Die Size</b>	Optional	Default value is the maximum height of all the grids. The height of a grid is calculated as: $\langle \text{grid vertical offset} \rangle + (\langle \text{grid cell height} \rangle + \langle \text{grid vertical gap} \rangle) * \langle \text{grid number of rows} \rangle - \langle \text{grid vertical gap} \rangle / 2$ (where $\langle \text{grid vertical offset} \rangle$ equals half of the vertical gap in normal cases).
<b>HSize</b>	<b>Horizontal Die Size</b>	Optional	Default value is the maximum of the most right side of all grids. The right side of a grid is calculated as: $\langle \text{grid horizontal offset} \rangle + (\langle \text{grid cell width} \rangle + \langle \text{grid horizontal gap} \rangle) * \langle \text{grid number of columns} \rangle - \langle \text{grid horizontal gap} \rangle$ .
<b>Grid</b>	<b>Grid</b>	Mandatory	<p>This is a <b>sub-node</b>. There can be one or more.</p> <ul style="list-style-type: none"> <li>The 'Grid' sub-nodes can be contained under an optional 'Grids' node.</li> </ul> <div style="border: 1px solid #ccc; padding: 5px; margin: 10px 0;"> <p> <b>Note:</b> This 'Grids' node was required up to AE v18.1 but as of v18.1.1, the list of 'Grid' nodes can be directly placed under the 'Die' root node.</p> </div> <ul style="list-style-type: none"> <li>On its turn a grid consists of a number of parameters, which can be a name of an XML element, an attribute or an XPath expression. <ul style="list-style-type: none"> <li>In this case, the XPath expressions are relative to the 'Grid' element.</li> </ul> </li> <li>See the table below for these grid-specific parameters.</li> </ul>

Table: Parameters for the sub-node 'Grid'

Element name	Name in UI	Usage	Description
<b>VSize , HSize</b>	<b>Vertical Cell Size , Horizontal Cell Size</b>	Mandatory	The height and width of the basic cell used in the grid (sizes are prior to any rotation).
<b>VGap , HGap</b>	<b>Vertical Gap , Horizontal Gap</b>	Mandatory	The vertical and horizontal gap between the different repetitions of a grid cell.
<b>Angle</b>	<b>Rotation Angle</b>	Optional	The rotation angle of the cell (positive values are clockwise). Value must be a multiple of 90 degrees. Default: no rotation.

Element name	Name in UI	Usage	Description
<b>NRows</b>	<b>Number of Rows</b>	Optional	The number of rows in the grid (i.e. the number of vertical repetitions of the grid cell). Value must be an integer larger than 0. Default : 1
<b>NCols</b>	<b>Number of Columns</b>	Optional	The number of columns in the grid (i.e. the number of horizontal repetitions of the grid cell). Value must be an integer large than 0. Default: 1
<b>Voffset</b>	<b>Vertical Offset</b>	Optional	The vertical offset of the first grid cell. Default value: $VGap/2$
<b>Hoffset</b>	<b>Horizontal Offset</b>	Optional	The horizontal offset of the first grid cell. Default value: 0

### Example

```
<?xml version="1.0" encoding="UTF-8"?>
<Dies>
  <Die>
    <Name>naam1</Name>
    <Grid>
      <VSize>80</VSize>
      <VGap>5</VGap>
      <HSize>80</HSize>
      <Angle>90</Angle>
      <NCols>2</NCols>
      <HGap>5</HGap>
      <NRows>6</NRows>
    </Grid>
  </Die>
  <Die>
    <Name>naam2</Name>
    <Grid>
      <VSize>50</VSize>
      <VGap>3</VGap>
      <HSize>50</HSize>
      <Angle>270</Angle>
      <NCols>1</NCols>
      <HGap>3</HGap>
      <NRows>6</NRows>
    </Grid>
  </Die>
</Dies>
```

This XML will create (or update) 2 dies.

## 6.110. Import Image (Classic)

The task converts pixel images to the Esko CT or LP file format.

You can also use it to convert RGB images to CMYK, probably for easier processing in the workflow.

You can also use prit to convert CMYK CTs with **Inkswitch** or **BlackSmith**.

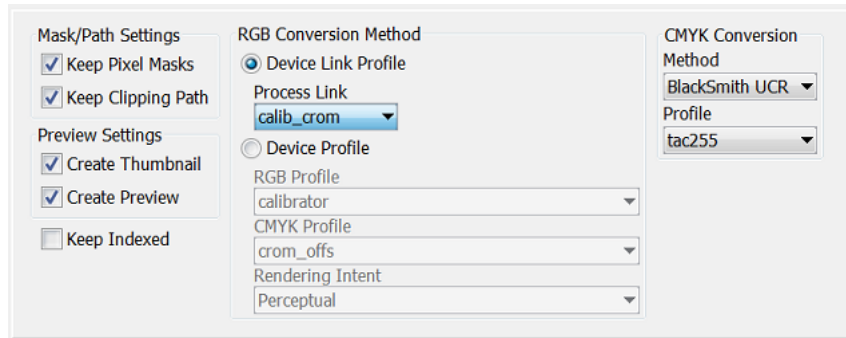

**Mask/Path Settings**

- Select **Keep Pixel Masks** to keep the original pixel mask in the output image.
- Select **Keep Clipping Path** to keep the original clipping path.

**Preview Settings**

- **Create Thumbnail.** Small RGB image used in an 'Info' panel in the Pilot or in the "File-Open" dialogs of Esko editors.
- **Create Preview.** Only used in PackEdge's low-quality view mode.

**Keep Indexed**

If the colors in the image are reduced ("indexed"), select this if you want to keep that in the output image.

**RGB Conversion Method**

There are two ways to convert RGB data to CMYK:

- **Device Link Profile**

This allows you to select a **Process Link**, made in *Color Pilot*. This option will give you the best result.

"Link profiles" describe a transformation from one device-dependent color space to another. This is actually a concatenation of a forward transformation of one profile and a backward transformation of another profile. A link profile takes complete care of the color management, so all other options are then disabled.

- **Device Profile**

This enables you to select a source and a destination (proofer) process. Use this option if you did not make a Process Link in Color Pilot but you still want a better color result. The process links will be made for you.

**RGB Profile:** Source profile used for conversion.

**CMYK Profile:** Destination profile used for conversion.

**Rendering Intent:**

- **Relative (no background):** Choose this if you do not want any background simulation. The white point of the source will be mapped on the white point of the destination process. This rendering intent takes into account the ability of the human eye to adapt to the surrounding white.

- **Absolute (background)**: Choose this if you want background simulation and you want an exact color match, including the paper simulation.
- **Perceptual**: This will result in no background simulation (white of reference color space is mapped on white of destination color space). Choose this when you don't care too much about an exact color match but when want the pictures at least to look nice on your proofer. It will give a visually pleasing result. If the gamut of the source is wider than the proofer, the entire gamut is shrunk so that it fits inside the gamut of the proofer.
- **Saturation**: Choose this if you care especially about saturated colors. This rendering intent will map saturated colors on saturated colors.



**Note:** For BGCMS profiles, **Perceptual**, **Relative** and **Saturation** are in fact identical.

### CMYK Conversion

Choose the conversion **Method** and its **Profile**.

Learn more about these conversions in [the documentation of Color Pilot](#).

## 6.111. Import JDF Layout (Classic)

---

This task handles JDF files generated by JDF compliant imposition programs (i.e the "*LayCrimp ICS*"). It reads the JDF layout and generates an imposed Normalized PDF per sheet side. The 1-up files referenced in the fully populated RunList in the JDF are converted to Normalized PDF files and saved in the output folder of the task. The JDF file must be version 1.2 , 1.3 or higher.

The JDF file contains two parts:

1. A page list, referring to PDF or PostScript files.
2. Geometrical layout info.

This task converts all PDF and PostScript files and creates 1 Normalized PDF file per sheet side.

Most tabs in this task ticket are identical to those in the '[Normalize PostScript/PDF/Illustrator 8.0 File \(Classic\)](#)' task.

- The '[Sheets](#)' tab differs a little from the Sheets tab in the task **Export Imposition to GRI File**, but has the same functionality.

Learn more in the dedicated document on "Commercial Print (Imposition) workflows in Automation Engine". Find it next to the "Complete Manual" of version AE **18.1** on <https://www.esko.com/en/Support/Product?id=Automation%20Engine&ver=18.1>.

- The '[Page Boxes](#)' tab is an extra tab.

### 6.111.1. Sheets

Indicate which sheet sides you want to import from the JDF layout.

For the **front** as well as the **back sheets**, you can either select **All** sheet surfaces or select a **Range** of sheets.

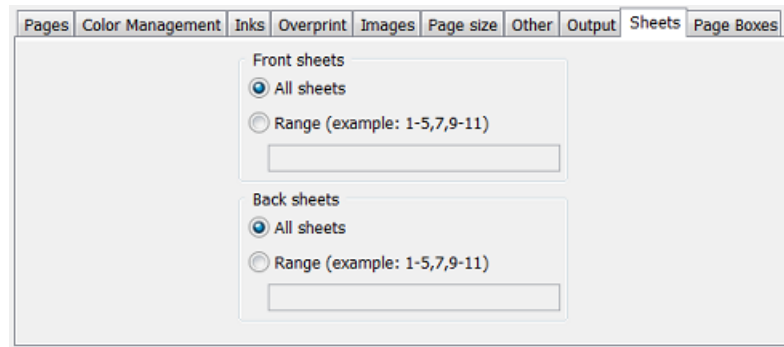

### 6.111.2. Page Boxes

- **Trim Box:**
  - **Plate:** Sets the Trim Box of the output PDF to the JDF Plate Media and `Plate TransferCurve CTM`. If not present in the JDF, select 'Paper'.
  - **Paper:** Sets the Trim Box of the output PDF to the JDF Paper Media and `TransferCurve CTM`. If not present in the JDF, select 'Surface Contents Box'.
  - **Surface Contents Box:** Sets the Trim Box of the output PDF to the 'Surface Contents Box' as defined in the JDF (default setting before AE 16.1).
  
- **Media Box:**
  - **Plate:** Sets the Media Box of the output PDF to the JDF Plate Media and `TransferCurveSet CTM`. If not present, it uses the JDF Paper Media. If not present, it uses the JDF Surface Contents Box as defined in the JDF.
  - **Fit:** Sets the Media Box of the output PDF by fitting the margins around all objects (default setting before AE 16.1).



**Note:** When importing JDF files from [Tilia Labs](#), you may want the Trim Box on 'Paper' and the Media Box on 'Plate'.

## 6.112. Import JDF Step & Repeat (Classic)

---

This task creates a Step & Repeat (PDFPLA) file based on a JDF file.

- When the JDF file contains a link to PDF 'station' files, the task performs a tabular Step & Repeat.
- When the JDF file contains a link to a CAD file and to its PDF 'station' files, the task performs a CAD-based Step & Repeat.



**Note:** The JDF should always contain a list of the input files.

### 6.112.1. Tab 'General'

- **Output Format:** Choose the type of PDF you want to create.
- **Unit:**
- **Limit Bleed:** The bleed mask is created by spreading the die shape. Use this option to limit that bleed to a specific distance.
- **SmartMarks.** If you wish, select or define a set of SmartMarks.
  - **Load Mark Set in bottom layer:** Select this if you want to make sure the marks are "behind" the graphics.
- **Screen Registration:** When selected, the origin of the screening will be reset for each station on the layout. This guarantees that the exact same screening will be applied for each station. This is for example required when printing stamps. When not selected, screening will be done continuously throughout the complete layout.



**Attention:** This option defines an attribute in the PDF that is only supported by **Imaging Engine** or **FlexRip**. It is ignored by any other RIP..



**Attention:** Screen registration is not available when you choose the output format **PDF**.

### 6.112.2. Tab 'CAD Options'

- **Mapping:** When the CAD file is a CFF2 or DXF file, you here select the set of mapping rules. These rules map line styles (cut, crease, bleed), layer names and color numbers onto ArtiosCAD line types. These sets of mapping rules can be created in Esko PackEdge or Plato. Learn more in [their user documentation](#), more specifically in their section on placing files (PackEdge) or on importing CAD data (Plato).
- The **CAD Style** changes the appearance of the (imported) ArtiosCAD type lines.



**Note:** This CAD Style is only applied on lines from the design (ARD) that was stepped in the layout file (MFG). Lines manually drawn next to the placed designs (the so called "objects at layout level") will always be ignored by the task.

The styles you can select here were also created in PackEdge or Plato. Learn more in [their user documentation](#), more specifically in the section on placing ArtiosCAD files, and the option for "CAD Style".

- **Include CAD info for Digital Flexo Suite:**

If you are using the Esko [Digital Flexo Suite](#) (DFS), select this option to add the technical inks data into the header of the output file (this is usually the cut and crease lines). This data is then visible in the Esko Bitmap Viewer and also embedded in the LEN files created by an Esko RIP.

The DFS can export this information into ACM files for an Kongsberg cutting table. In Esko PlatePatcher workflows, this information can be used to print onto the plastic sheet where the

pieces of flexo plate are re-assembled. These technical lines can also represent text that is then added onto the (back of the) flexo plates, using a pen on the Kongsberg table.



**Attention:** This option is disabled when you choose the output format (native) PDF.

### 6.112.3. Tab 'Sheet'

- **Sheet Size:** If you want to use a custom sheet size instead of the sheet size defined in the JDF file, then select **Set custom sheet size** and enter its dimensions.
- **CAD Layout Position:** The position on the sheet of the bounding box of all cut lines in the CAD layout in the JDF.

If you want to use a different position than the one defined in the JDF file, then select **Set custom position**.



**Note:** Take into account the point of **Origin** from which the repetition will be built. This is defined in the JDF and is always bottom left.

- **Position on Sheet:** click or drag the inner blue rectangle (the bounding box of the CAD Layout) in a position versus the outer grey rectangle (the sheet).
- **Offset:** Define by how much the CAD Layout should be offset from the sheet corner, horizontally and vertically.

### 6.112.4. Tab 'Plate'

- **Plate Size :** Select **Set custom plate size** when the plate size needs to be different than the sheet size. Then enter your custom plate size below (and possibly also the sheet position and offset).
- If you want, enter horizontal and/or vertical **Shrink** values (in percentage) to compensate for printing distortion (especially in Flexo).

The default value is 100, both horizontally and vertically, which means no distortion compensation. Learn more about when and how they are applied in the topic 'shrink' [on this page](#).

- Define the **Sheet Position** by clicking or dragging the sheet (inner rectangle) to its position versus the plate (outer rectangle).
- **Offset:** When enabled, add a H and/or V offset of the sheet versus the plate.



**Note:** Take into account the point of **Origin**  from which the repetition will be built. This is defined in the JDF and is always bottom left.

## 6.113. Import JDF Stripping (Classic)

Learn more in the dedicated document on "Commercial Print (Imposition) workflows in Automation Engine". Find it next to the "Complete Manual" of version AE **18.1** on <https://www.esko.com/en/Support/Product?id=Automation%20Engine&ver=18.1>.



## 6.114. Import Picture List

### Concept

This task imports a text file (.picl) describing the name, position and size of the bounding box of the to be placed art (PDF) and creates a layout PDF+ as output file.

These Picture List files can be created in ArtPro or ArtPro+, using the Export Picture List function. A 3rd party application can also create it as long as the ASCII text file has the same construction.

Use case: An MIS exports a basic form of layout specification, focussing on the required stations to be put on the layout sheet. This basic text file can be seen as poor man's JDF.



**Note:** This functionality will mainly be used interactively in ArtPro+.

### Format and General Behavior

Format example:

```
ArtPro Picture File V1.0
units mm
size 42.9999 80.7174

006_100_image A.pdf -1.00005 38.7175 49.9999 49.9999 0 25 23.5 TrimBox
006_100_image B.pdf -0.999322 -4.99999 49.9992 49.9992 0 24.9993 23.5 TrimBox
```

First 3 lines:

1. ArtPro Picture File V1.0 (header)
2. Units
3. Size: The size of the sheet / output file: Height x Width (Media Box), in the unit set above.

Then, per file to be placed, a line describing:

1. File name. The task places the center of the referenced file on the center of the specified box (see '5'). Learn below about the folders that will be scanned.
2. Position of the bounding box. Top, left, width and height of the bounding box.
3. Rotation. Zero or a multiple of 90 degrees.
4. Placed file center offset.
5. Page box to be used for these measurements.

When any file to be placed can not be found, the task will finish with error.

### Task Settings

By default the task looks for the listed files next to the .picl input file.

- **Picture Folders.** Use this option to define extra places where the task should look for them. Browse or use SmartNames to define their path.

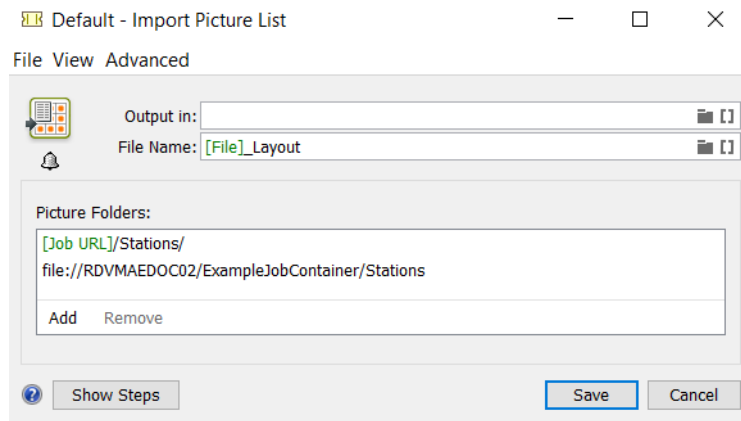

Empty Picture Folders are ignored.

## 6.115. Import Substrate Sizes from XML

This task is documented in the separate chapter [Sign & Display Workflow](#) on page 953. Find a direct link [here](#).

### 6.115.1. Import Substrate Sizes from XML

This task is documented in the separate chapter [Sign & Display Workflow](#) on page 953. Find a direct link [here](#).

## 6.116. Import Order Material from XML

### Concept



**Note: 'Order Material'** is a term first used in AE's browser client, the one used in the QuickStart deployment. An order material is the substrate that is mentioned on the order ; it is what needs to be used to print on or produce with. The name this material has on the order is typically the term that is used in the MIS/ERP, which is probably also the one that your customer uses when placing this order.

This task allows to use an XML file to import **Order Materials** into the Automation Engine database. When the material already exists (in the Automation Engine Order Materials database), it will update its properties.

These materials can then be used in the [Add to Products task](#).

This XML file typically comes from a business system: the MIS/ERP that also manages the stock of printing material.



**Note:** This task can not delete an order material. You need to do this manually in the [Order Materials view](#).

**Usage**

The task panel serves to map the language in the XML to the required terms in Automation Engine. The result will appear in the view .

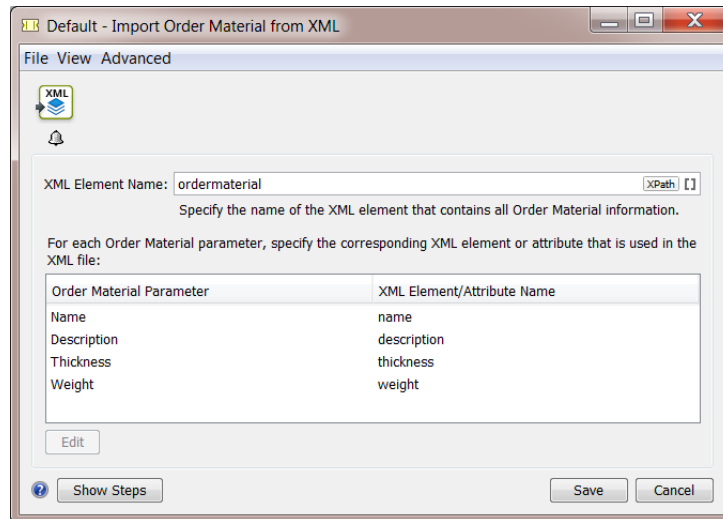

- **XML Element Name:** You first need to specify the name of the XML element that contains the specification of an order material. You can specify it by any combination of a fixed value and a SmartName, by an XPath expression or by a public parameter.



**Note:** When you import an order material with the same name as one that already exists, it will be overwritten.

- **XML Element/Attribute Name:** This name of the XML element or attribute is used to update an **Order Material Parameter**. You can specify it by any combination of a fixed value and a SmartName, or by an XPath expression (then relative to the above specified **XML Element Name**).

When the name of the XML element or attribute ...

- is empty, the order material parameter is not modified.
- is an *XPath expression* (starts with `xpath:`), the order material parameter is updated with the result of the XPath expression. When the XPath expression does not select any XML element or attribute, the order material parameter is not updated.
- is not an XPath expression, the task searches for a direct child element with a matching local name. If not found, the task searches for the attribute with a matching name. If not found, the order material parameter is not modified.
- Click **Edit** to map any of these parameters:

**Table: Data Type of Parameters**

Order Material Parameter	Data Type
description	string

Order Material Parameter	Data Type
name	string
thickness	number in mm
weight	number in gram

## 6.117. Inspect Artwork

---

This task is documented in the separate chapter [Quality Control tools](#) on page 1077. Find a direct link [here](#).

## 6.118. Inspect Barcodes

---

This task is documented in the separate chapter [Quality Control tools](#) on page 1077. Find a direct link [here](#).

## 6.119. Inspect Braille

---

This task is documented in the separate chapter [Quality Control tools](#) on page 1077. Find a direct link [here](#).

## 6.120. Inspect Spelling

---

This task is documented in the separate chapter [Quality Control tools](#) on page 1077. Find a direct link [here](#).

## 6.121. Inspect Text

---

This task is documented in the separate chapter [Quality Control tools](#) on page 1077. Find a direct link [here](#).

## 6.122. Integrate via External Hot Folder

---

This task allows to integrate external (prepress) applications into your workflow. The only requirement is that the external application works with **hot folders**.

1. In the ticket, you define the location of the **hot folder** used by the external application, as well as the **Result** subfolders in which the external application will output processed files (the **OK Folder**), failed files (**Error Folder**) or files that resulted in warnings (**Warnings Folder**).



**Attention:** You need to define a different folder for each output state. This can not be the same folder.

2. When you select a file and launch this task, the task first copies the file to the **external hot folder**.
3. The external application picks up the files in its **hot folder** and processes them. The processed files are saved in the subfolder that matches the processing result: **OK**, **Warning** or **Error**.
4. Automation Engine monitors the **OK**, **Warning** and **Error** folders for any files that have been processed.



**Important:** As mentioned above, these have to be three different folders.

5. When Automation Engine detects a file in the **OK** folder, it copies it to the **Output** folder defined in this ticket. Depending on your settings, **Error** or **Warning** files might also be copied into the **Output** folder, or they might be deleted.

Output in: [Job URL]/Processed

File Name: [File]\_Processed

Hot (External)

Folder: file://MyServer/AdobeMagic\_HotFolder/Input

File Name: [File]

Result

OK Folder: file://MyServer/AdobeMagic\_HotFolder/Success

OK File Name: [File]

Use warning output

Warning Folder:

Warning File Name:

Use error output

Error Folder: file://MyServer/AdobeMagic\_HotFolder/Error

Error File Name: [File]\_Error

Error Files:  Delete error files  Move error files to output folder

Error when no result after 1 hour

In the **Error** area of the ticket, you can define an amount of time after which the external processing should automatically be considered as **failed**. To do this, enable the option "**Error when no result after**" and select a time period.

## 6.123. Interact using JDF

This task is documented in the chapter [Integrating with External Systems](#). Find a direct link [here](#).

## 6.124. Interact using JMF

---

This task is documented in the chapter *Integrating with External Systems*. Find a direct link [here](#).

## 6.125. Integrate with WebCenter

---

This task is documented in the chapter *Integrating with WebCenter*. Find a direct link [here](#).

## 6.126. Interact with Database

---

This task is documented in the chapter *Integrating with External Systems*. Find a direct link [here](#).

## 6.127. Interact with SAP

---

This task is mentioned in the chapter *Integrating with External Systems*. Find a direct link [here](#).

## 6.128. Interact with Web Service

---

This task is documented in the chapter **Integrating with External Systems**. Find a direct link [here](#).

## 6.129. Join

---

This Workflow Control is documented in the chapter "Workflows". See *Fork and Join* on page 837.

## 6.130. Join XML Files

---

This task is documented in the chapter **Integrating with External Systems**. Find a direct link [here](#).

## 6.131. Link Product To Job

---

This task is documented in the chapter *Products* on page 594. Find a direct link [here](#).

## 6.132. Load Structural File (Classic)

### Concept

This task loads a structural design file into a graphics file.

The structural file is loaded in a dedicated new layer named `Structure_`[name of structural file]. The structural file is put in a technical ink (as defined in the **CAD Style**, see below).



**Tip:** The output file can be used as an input file for the [Export to 3D \(Classic\)](#) task.



**Note:** When the input file is a normalized PDF that already contains a structural file (one that was loaded in Esko PackEdge, ArtPro, DeskPack or by an Automation Engine task), then the task ends with an error.

### Supported Types of Structural Design Files

This task can load these types of structural files:

- CAD files: **ARD, CF2, DXF** files. For CF2 or DXF files, you have to indicate a **Mapping** file to map their file attributes onto ArtiosCAD-like line types (to become cut, crease or bleed lines or to be ignored). The **CAD Style** file is needed to define their appearance, for example the color they get. Mappings and CAD styles can be defined in Esko editors.
- Collada files: **DAE, ZAE** file. These files need to have a **printable area**. When the file has multiple printable areas, the area that matches the size of the selected page box gets selected. When the file has no or multiple matching printable areas are found, the task ends with an error.
- Esko Flexible file: **BAG** file. This file type was created before ZAE was supported.



**Important:** The structural file is not rotated.

**Positioning**

- **Reference:** The structural object will be positioned in relation to the selected page box (**Media, Crop, Trim, Bleed, Art Box**).



**Note:** The task ends with a warning when the dimensions (bounding box) of the structural file do not match the size of the selected page box.

- **Position:** Additionally, you can use the align tool for more specific 9-point-positioning. The smaller square in the graphic represents the selected type of Box.
- **Fit trim box to the structural design:** Optionally, you can fit the trim box to the structural design.



**Note:** When you select this, the margins will keep their original size (i.e. the media box will change).



**Note:** All page boxes, except the Media Box, are placed relative to the top left of the Trim Box. The Media Box is defined as a margin around the Trim Box (top - bottom - left - right).

## 6.133. Manage Color (Classic)

---

With this task, you can:

- convert a CMYK file to another CMYK profile,
- re-separate a CMYK file so that it contains less CMY and more K, while keeping the image looking the same,
- both convert and re-separate your CMYK file.

This task takes PDF and Normalized PDF files as input. When working with regular PDFs, it will automatically normalize them using the **Normalize ticket** set in the **Configure** tool (see [Processing Preferences](#) on page 233).

### 6.133.1. Converting to another CMYK Profile

You can convert a file to another CMYK profile if for example you want to print it on a different substrate, on a different press, or even with a different printing process (offset, digital printing...).

In **Actions**, select **Convert color space** to convert your input file to another CMYK profile. This displays extra parameters below it.

1. Select the profiles to use when converting your input file.

You can choose either:

- individual source and destination profiles (this is the default option). In this case:
  1. In **Use**, select **Source and Destination Profiles**.
  2. In **Source CMYK Profile**, select the source profile to use for the conversion in case you are not using your input file's profile.

This can be an Esko or an ICC profile and you can use a SmartName (resolving to the full profile name) to set it. By default this is `ISOcoated_v2_eci.icc`.

3. If your input file has a CMYK profile and you want to use it for the conversion, select **Use document profile if available**.



When processing a file without a profile, the task will use the **Source CMYK Profile** you selected.

4. Choose what **Destination CMYK Profile** to convert your file to.

This can be an Esko or an ICC profile and you can use a SmartName (resolving to the full profile name) to set it. By default this is `ISOcoated_v2_eci.icc`.

- an ICC device link (which contains a source and a destination profile). In this case:

1. In **Use**, select **ICC Device Link**.
2. Select the **ICC Device Link** to use.

You can browse to it, enter its full name including the `.icc` extension, or use a SmartName resolving to its full name.



**Note:**

- You can create ICC device links in 3rd-party applications (for example ColorLogic or Alwan).
- When using an ICC device link, you cannot use certain color management options (See 'black point compensation' (point 3) and 'keeping colors pure' (point 4)).

2. Choose the **Rendering Intent** to use when converting the colors.

A **Rendering Intent** is a part of the color strategy that handles the conversion of out-of-gamut spot colors and of the background color.

Each rendering intent does this in a different way, so you should choose the one that is more adapted to the way you are printing and the result you want to achieve:

- Use the **Relative Colorimetric** rendering intent if you don't want to simulate the source background (the point that has 0% of all inks in the source profile).

This will proof your file as if the proofer substrate was exactly the same as the substrate defined in your source profile.

For example: your press prints on cream colored card stock whereas your proofer prints on bright white paper, but you don't want to simulate the cream background on your proof.



With this rendering intent, colors from the source profile that cannot be reproduced by the proofer will be converted to the closest color(s) the proofer can reproduce.

In some cases several colors will be converted to the same color, which means that you can sometime lose some detail, especially in dark saturated areas and the dark parts of gradations.

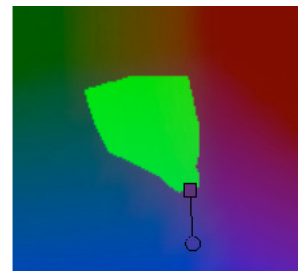
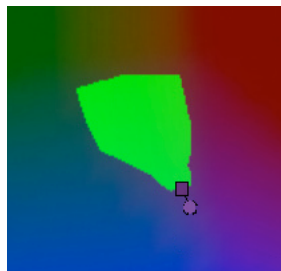

Note that typically the proofer profile has a bigger gamut than the press profile, so there are not many colors that the proofer cannot reproduce.

- Use the **Absolute Colorimetric** rendering intent if you want to simulate the source background to get as exact a color match as possible.

For example: you do want to simulate the cream colored card stock used on your press on your proofer substrate, to see how the final output will look like (this doesn't only affect the white but all the colors in your file).



As with the Relative Colorimetric rendering intent, colors from the source profile that cannot be reproduced by the proofer will be converted to the closest color(s) the proofer can reproduce, meaning you can sometime lose some detail, although there are typically not many press colors that a proofer cannot reproduce.

- Use the **Perceptual** rendering intent if you are not trying to get an exact color match but want the proof to look visually pleasing.

If there are colors from the source profile that cannot be reproduced by the proofer, this will shrink the source gamut to fit inside the gamut of the proofer, so that all colors are converted (even the colors already in the proofer's gamut), but the relationship between colors is kept.

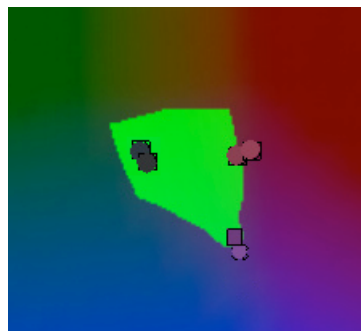

This means that colors won't be really accurate, but you won't lose detail in dark saturated areas or gradations.

This rendering intent is most commonly used in commercial printing (for newspapers, magazines, posters...).

- Use the **Saturation** rendering intent if you mostly want to make sure the colors on your proof are saturated enough.

Colors from the source profile that cannot be reproduced by the proofer will be mapped onto close saturated colors that are in the proofer's gamut.

This rendering intent is most commonly used for business presentations containing graphics, or cartoons/comics.





**Note:**

- If you are working with Esko source and destination profiles, you can use the **Absolute Colorimetric** or **Relative Colorimetric** rendering intent.
- If you are working with ICC source and destination profiles, you can use any rendering intent.

You can also set the rendering intent with a SmartName, resolving to 2 (for **Perceptual**), 3 (for **Relative Colorimetric**), 4 (for **Saturation**) or 5 (for **Absolute Colorimetric**).

3. If you cannot reproduce the same range of black on output, select **Use black point compensation** to avoid losing some detail in the shadow areas.

This can be the case for example if you originally printed a job on coated paper, but now need to print it on uncoated (as the uncoated paper will absorb more of the ink and give less of a sharp, saturated result).

	
Coated	Uncoated

Without black point compensation, some of the details in the darkest areas can get lost.

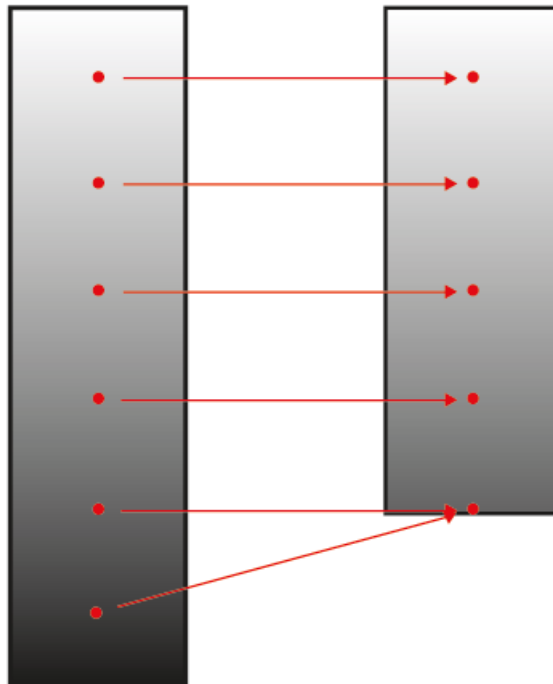

Black point compensation shrinks the whole black range proportionally, so that both the shadows details and the relationships between different tints of black are kept.

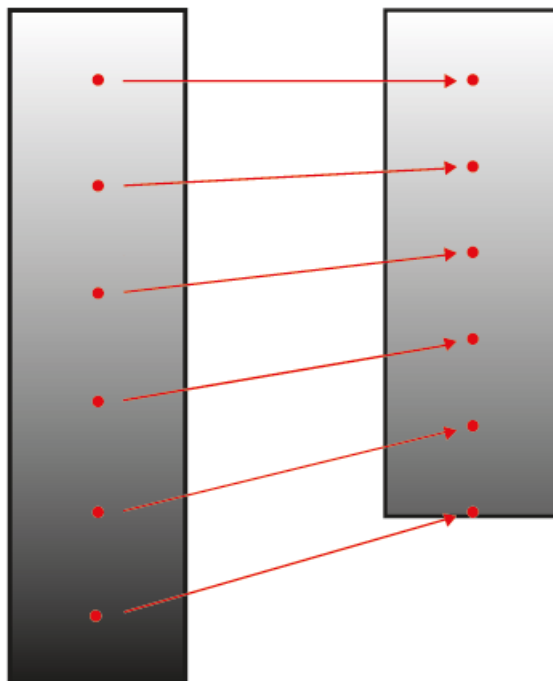

4. If you want to keep certain colors pure after conversion, click **Keep Colors Pure...** and select **Yes** for the colors you want to keep pure (or use a SmartName resolving to  $\Upsilon$ ES).

Keeping a color pure means that the conversion will not use other inks to reproduce that color.

So for example a 100% yellow object will be converted to the percentage of the output yellow that gives the closest color on print, but will never be made of 97% yellow and 3% magenta.

This helps you avoid unwanted printing effects, like having small dark dots in an otherwise smooth color patch (also called "contamination").



Removing those small dots increases the color difference slightly but avoids graininess on print.

You can choose to keep primary colors (**Cyan, Magenta, Yellow**) and/or secondary colors (**Red, Green, Blue**) pure. Secondary colors are made of a combination of primary colors (for example green is a combination of cyan and yellow).

You may want to keep certain colors pure and not others depending on the results you get with your particular job or press.

- When you keep a primary color pure, all tints of that color are kept pure (so an object that is 50% yellow will stay only yellow). Objects that are already multicolor (for example 50% yellow + 15% magenta) will be converted as usual.
- When you keep a secondary color pure, all tints made of equal amounts of primary colors are kept pure (so for example 50% cyan + 50% yellow is kept pure, but 50% cyan + 60% yellow is not).

By default, the primary colors are kept pure.



**Note:** When using the **Absolute Colorimetric** rendering intent, the colors are not kept pure in the very light colors, in order not to interfere with background simulation.

5. Select what objects in your file you want to convert in **Apply on**. This can be either:

- **Images and Linework,**
- **Linework only,**
- **Images only.**

You can also set this with a SmartName, resolving to `images_and_linework`, `linework_only` or `images_only` (SmartNames are case insensitive).

6. Select **Keep registration color (400%)** if you use marks in your file and if you don't want them to be converted to the new profile (you want them to stay 100% of each CMYK color).

7. Select **Flatten document** if you are experiencing unexpected results in color conversions (if after conversion the color of some blend modes or other objects on top of each other looks different).



**Attention:** We recommend you only use this in case of conversion problems, as it will remove any transparencies in your file.



**Note:** Flattening your file turns vignettes into images. This means that:

- If you selected **Flatten document**, vignettes will be color converted when you chose to convert **Images and Linework** or **Images only**.
- If you didn't, they will be converted when you chose to convert **Images and Linework** or **Linework only**.

### 6.133.2. Reseparating your CMYK File

Reseparating a file is replacing some amount of Cyan, Magenta and Yellow in the file (that would give grey) by a certain amount of Black, giving the same grey color.

Objects that are only Cyan, Magenta or Yellow (or only two of these colors) are kept as they are.

This can help you save on CMY inks, have a more stable output (less risks of color casts in neutral areas) or have more detail in the shadow areas.

In **Actions**, select **Reseparate** to reseparate a CMYK file so that it contains less CMY and more K, while keeping the image looking the same.

This displays extra parameters below it.

1. Choose the profile to use when reseparating your input file:
  - a) In **CMYK Profile**, select the profile to use in case you are not using your input file's profile.
 

This can be an Esko or an ICC profile and you can use a SmartName (resolving to the full profile name) to set it. By default this is `ISOcoated_v2_eci.icc`.
  - b) If your input file has a CMYK profile and you want to use it for reseparating, select **Use document profile if available**.

When processing a file without a profile, the task will use the **CMYK Profile** you selected.

2. Select what type of reseparation you want to do in **Purpose**:
  - **Ink Saving** replaces as much CMY as possible by Black.
 

This is a good choice if you want to save on CMY inks.
  - **GCR** (Gray Component Replacement) replaces CMY by Black in the grey and the saturated areas.
 

This is a good choice if you want to avoid color casts in the grey areas, and to avoid having too much ink in the dark saturated areas, which could cause problems with the substrate.

This is selected by default.
  - **UCR** (Under-Color Removal) only replaces CMY by Black in the dark neutral areas.
 

This is a good choice if you want to avoid color casts in the grey areas, and to have more detail in the shadow areas.



In the example below, you can see the results of applying ink saving on your file. The first row shows the original file, and the second row shows the file after applying ink saving.

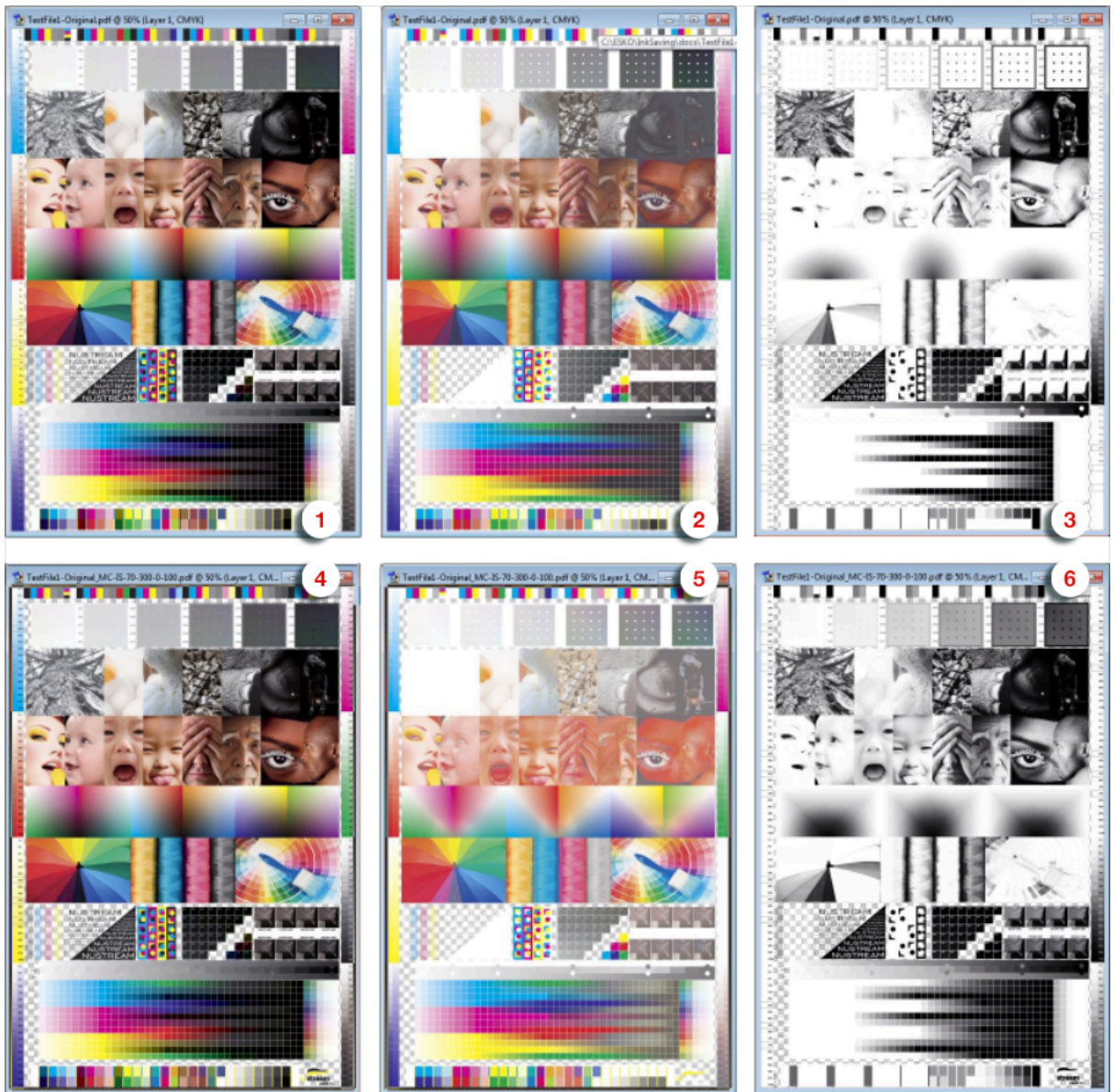

1. Original file, CMYK separations
2. Original file, CMY separations
3. Original file, K separation
4. File after ink saving, CMYK separations
5. File after ink saving, CMY separations
6. File after ink saving, K separation

You can see that after ink saving, the file contains a lot less CMY and a lot more K.

You can also set type of reparation to do with a SmartName, resolving to `ink_saving`, `GCR` or `UCR` (SmartNames are case insensitive).



3. In **Range**, choose how much of the CMY inks that can be replaced by Black you want to actually replace.

This depends on the **Purpose** you chose:

- For **Ink Saving**, this is how much CMY inks in **all areas** of the file you want to replace.
- For **GCR**, this is how much CMY inks in the **grey and saturated areas** of the file you want to replace.
- For **UCR**, this is how much CMY inks in the **grey areas** of the file you want to replace.



**Note:** You can set all percentage values in this task with SmartNames.

4. In **Total Ink**, select the maximum amount of ink (CMYK) that you want to print.

If you don't limit the amount of ink, you can get a maximum of 400% (100% Cyan + 100% Magenta + 100% Yellow + 100% Black), which tends to cause problems on most substrates (slow drying, web growth, or even a risk of tearing).

Additionally, limiting the maximum amount of ink used can make printing jobs less expensive.

The maximum percentage of ink you should use depends on your printing process and substrate. For example for newsprint, you may only want to have a maximum of 240%, while you may be able to use 280 to 320% on a glossy substrate.

The default **Total Ink** percentage set in the task is 310%.

5. Define the minimum and maximum amount of Black that you want to have in your output file:

- a) In **Start K**, define from which (minimum) final Black value you want to start reseparating.

If replacing CMY by Black in a certain color gives a Black percentage lower than this, the CMY won't be replaced.

This is to avoid having really small Black dots, which can be prone to high dot gain, making them less stable than the equivalent CMY dots.

- b) In **Max K**, define until which (maximum) final Black value you want to start reseparating.

If replacing CMY by Black in a certain color gives a Black percentage higher than this, the CMY won't be replaced.

This is to avoid having too dark shadows and losing detail.

6. Select what objects in your file you want to reseparate in **Apply on**. This can be either:

- **Images and Linework,**
- **Linework only,**
- **Images only.**

You can also set this with a SmartName, resolving to `images_and_linework`, `linework_only` or `images_only` (SmartNames are case insensitive).

7. Select **Keep registration color (400%)** if you use marks in your file and if you don't want them to be reseparated (you want them to stay 100% of each CMYK color).
8. Select **Flatten document** if you are experiencing unexpected results after reseparating a file (if after reseparation the color of some blend modes or other objects on top of each other looks different).



**Attention:** We recommend you only use this in case of reseparation problems, as it will remove any transparencies in your file.



**Note:** Flattening your file turns vignettes into images. This means that:

- If you selected **Flatten document**, vignettes will be color converted when you chose to reseparate **Images and Linework** or **Images only**.
- If you didn't, they will be converted when you chose to reseparate **Images and Linework** or **Linework only**.

### 6.133.3. Converting and Reseparating your File

When converting and reseparating your file(s) at the same time, you need to:

1. Select the **Source profile**, **Destination profile** and **Rendering Intent** for the *conversion*.



**Note:** In this case, you cannot use an *ICC device link*.

2. Select what type of *reseparation* you want to do and set the appropriate options.
3. Select on which objects to perform **both** the conversion and the reseparation, whether to keep objects in **registration color** untouched, and whether to **Flatten** your file.



**Attention:**

- When using one **Manage Color** task to both convert and reseparate, the conversion will try to keep the black channel unchanged, so as not to affect the reseparation.
- When using two **Manage Color** tasks after each other, one for conversion and one for reseparation, this will not be the case, so the output will be different.

If you want to perform both conversion and reseparation on your file(s), we recommend you use one **Manage Color** task for both instead of a task for each in your workflow.

## 6.134. Manage Milestone

---

The **Manage Milestone** task is documented [here](#) in the chapter on *Jobs* on page 538.

## 6.135. Manage Product Status

---

This task is documented in the chapter on *Products* on page 594. Find a direct link [here](#).

## 6.136. Map Data

---

This task is documented in the chapter [Integrating with External Systems](#). Find a direct link [here](#).

## 6.137. Mark as Proof

---

Learn more in the dedicated document on "Commercial Print (Imposition) workflows in Automation Engine". Find it next to the "Complete Manual" of version AE **18.1** on <https://www.esko.com/en/Support/Product?id=Automation%20Engine&ver=18.1>.

## 6.138. Mark File

---

This Workflow Control is documented in the chapter [Workflows](#). See [Mark File and Select Marked File](#) on page 828.

## 6.139. Merge PDF Files (Classic)

---

This task combines multiple PDF files into one single PDF.

Multiple normalized PDF Files can be merged into a single normalized PDF File.

Multiple native PDF files can be merged into a single native PDF file.



**Attention:** When working with PDF+ files, we advise to use the task [Merge PDF files](#) on page 382.

Be aware of these effects and limitations:



**Attention:**

- By default all hidden layers are made visible again.  
Tip: You can remove the hidden layers before merging the PDF files by first using the [Optimize PDF](#) task and its option 'Remove Non Printable Layers'.
- All pages of all incoming PDF files are added in the same order as the inputs of the task. To control the order of the files, use the Workflow Control [Sort](#).
- Normalized and native PDF files cannot be mixed together.
- The page sizes of the normalized PDF files must be the same.
- The output PDF will only be normalized if all the input files are normalized files and have the same media and trim boxes. In case there is a mismatch in size, the task will fail.
- For normalized PDF files, the XMP information of the first file will be copied into the resulting PDF file. Then it will be updated with information from the other normalized PDF files.

## 6.140. Merge PDF files

---

### Concept & General Behavior

The task combines multiple PDF files into one single PDF.

Supported input files:

- PDF and PDF+
- PDF with Esko XMP
- Normalized PDF

Output file: A single merged PDF file.

General behavior:

- All pages of all input files are added in the same order as they are input to the task.
- All separations of all input files are added in the same order as they are input to the task. If this is not wanted, check one of these workarounds:
  - Make sure the wanted order of separations is present in the first input file.
  - After this task, change the order of separations of the resulting merged file by using the task "Optimize PDF" or 'Apply PDF Action List'.
- For PDF files with an output intent, the output intent of the first file will used for the resulting PDF.
- For PDF files with a distortion, the distortion of the first file will used for the resulting PDF.
- When using normalized PDF files:
  - Multiple normalized PDF Files will be merged into a single normalized PDF File.
  - The task will fail when trying to merge Normalized and non-normalized PDF files together.
  - The task will fail when merging normalized PDF files of which the media and/or trim box are not the same.
  - The XMP information of the first Normalized PDF file will copied into the resulting normalized PDF file and then updated with information from the other normalized PDF files.



**Warning:** When not defining a different output file name, the input file can be overwritten with the output file.

### Task Settings

- **Recalculate marks:** Select this to make the task recalculate the Dynamic Marks in a PDF+ into the output PDF.
- **Update external references:** Select this to make the task update any linked images, placed artworks or structural design files into the output PDF.
  - **Report missing external reference as:** Select how the task should inform you of a missing reference.

## 6.141. Modify Workflow Parameter Values

---

This Workflow Control is documented in the chapter "Workflows". See [Modify Workflow Parameter Values](#) on page 808.

## 6.142. Move Job to Inactive Jobs

---

This task relates to near-line storage for AE SaaS customers.

Learn more in the chapter [AE SaaS: When your AE is in a Data Center](#) on page 1633, in the section about [Inactive Jobs](#), on the page [Task 'Move Job to Inactive Jobs'](#) on page 1652.

## 6.143. Move Inactive Job to Jobs

---

This task relates to near-line storage for AE SaaS customers.

Learn more in the chapter [AE SaaS: When your AE is in a Data Center](#) on page 1633, in the section about [Inactive Jobs](#), on the page [Task 'Move Inactive Job to Jobs'](#) on page 1653.

## 6.144. Normalize PDF File (Classic)

---



**Note:** Learn about the concept of 'Normalization' in [Normalized PDF and XMP in Automation Engine](#) on page 44.

### 6.144.1. Colors

You here define how (non-process) colors will be converted during Normalization.



**Note:** The conversion uses the technology from Esko's **Color Engine**.

**Objects With Profile Tags:** Choose how to convert non process color images that have an embedded ICC profile:

- **Ignore Tag:** To use the **Default RGB Profile** or **Default Gray Profile** (that you define below) to convert the RGB or gray images. This disregards the images' own profiles.
- **Convert Using Profile Tag:** To use the images' own profiles to convert them to CMYK.
- **Rendering intent**
  - **Relative (no background):** Choose this if you do not want any background simulation. The white point of the source will be mapped on the white point of the destination process. This rendering intent takes into account the ability of the human eye to adapt to the surrounding white.

- **Absolute (background):** Choose this if you want background simulation and you want an exact color match, including the paper simulation.
- **Perceptual:** This will result in no background simulation (white of reference color space is mapped on white of destination color space). Choose this when you don't care too much about an exact color match but when want the pictures at least to look nice on your proofer. It will give a visually pleasing result. If the gamut of the source is wider than the proofer, the entire gamut is shrunk so that it fits inside the gamut of the proofer.
- **Saturation:** Choose this if you care especially about saturated colors. This rendering intent will map saturated colors on saturated colors.

**Default CMYK Profile:** Select the default profile to use for CMYK objects without an embedded color profile. It will be used as a source profile for color-space conversions.

You can choose any CMYK profile in the color engine database.

**Default RGB Profile:** Select the default profile to use for RGB objects without an embedded color profile. It will be used as a source profile for color-space conversions.

You can choose any RGB profile in the color engine database.

**Default Gray Profile:** Select the default profile to use for gray objects without an embedded color profile. It will be used as a source profile for color-space conversions.

You can choose:

- any gray profile in the color engine database
- **Convert to Black Channel**, if you want your grayscale object to only have a value in the Black separation when outputting it to CMYK.

**Output Color Profile:** Enter the color-space of the output device (for example proofer or press).

You can choose any CMYK profile in the color engine database.

## 6.144.2. Separations

You here define the ink attributes.



**Note:** The settings in this tab only affect the Normalized PDF output file. They are ignored again if the file is later output as a native PDF.

- **Use ink attributes from file if available:** If the input file contains rulings, angles and dot gain compensation, select this option to use these attributes. Other settings in this tab will be overruled. This option is relevant when you normalize PDF files that were exported from earlier normalized files.
- Choose your **Preferred Ink Book**. When you type an ink name in the table, the task will first look up its color information (CMYK, RGB, or LAB values) or the ink type (Technical, Varnish, Opaque...) directly in the PDF. If it cannot find it there, it will look it up the **Preferred Ink Book** that you define here.

For example, if you type 154 as ink name, and your preferred ink book is `Pantone Colors Uncoated`, the task will automatically suggest the `PANTONE 154 Uncoated` ink.

- In the Inks panel, click an (empty) item in any column to change or add or select a new value.
- The **Ink Book** column shows the first ink book containing this ink (or your **Preferred Ink Book** if it contains the ink). To select another ink book, click the name of the ink book.

- If the **Ruling**, **Angle** and **Dot Shape** information are defined for this ink, they will be shown automatically. If they aren't, you can enter them manually.



**Note:** You can also specify **Default Values** to use **when a ruling, angle or dotshape is not specified** (in the file or in the above panel).

Default values, used when a ruling, angle or dotshape is not specified:

Ruling:  lpi    Angle:  °    Dotshape:

If there are inks specified in the list, but no default values are set, factory settings will be used for ruling (120 lpi) and angle (45°).

- If the **Ink Type** shown is not correct, click it to change it.
- Do the same for any remaining inks you want to define.
- If you want, you can change the ink order using the **Move Up** and **Move Down** buttons.

## 6.145. Normalize PostScript / PDF / Illustrator 8.0 File (Classic)

### 6.145.1. Pages

#### Page selection

Define which pages you want to keep in your output PDF file. Select **All Pages** or specify a **Range**.

#### Split Up a Multi-Page File

Select this to split the multi-page input file into multiple output files.

- **Maximum Pages per File:** Define the amount of pages you want in each output PDF file. The last output file can have less pages than this value. Each output file is saved with a numbered suffix (\*\_001, \*\_002, \*\_0001\_001...) or it gets the Output Name.
- **First Page number in Output**

You can here define the "label" of the first page in the output. For example: when you normalize a 4 page document, and set '3' in this field, the pages will be labeled 3-4-5-6.

**Merged Tiled CT Files to one CT**

Some ArtPro files include tiled CT images. Large size graphics can so contain thousands of these small CTs.

Select this toggle to merge these tiles back into one CT. This so improves the editability and processing of the output file.

This option has no effect when you import a file that has no tiled CTs.

**Merge Separated File to Composite Page**

This option merges separated PostScript or PDF files (single- or multi-page) to a composite PDF file.

- **Optimize Merged File.** Use this option when you need to edit the resulting file.
- **Password:** When normalizing password protected PDF files, enter its password here.

**6.145.2. Color Management**

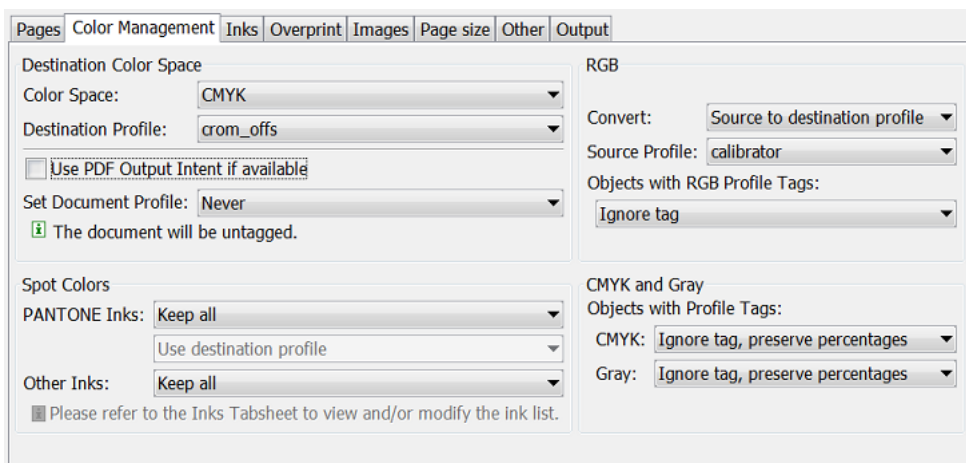

**Destination Color Space**

You here define the color space of the output file.

- **Color Space:** Choose CMYK or Grayscale.
- **Destination Profile:** Choose a color profile. Only CMYK and Grayscale profiles are supported. Choose between standard ICC profiles and Esko profiles made in Color Pilot.
- **Use PDF Output Intent if available:** In some PDF files, the 'PDF Output Intent' is defined, this is the intended output color space. For example PDF/X-3.

If you want to use the color space as defined in this 'Output Intent', select this option. If you selected it for a file without PDF 'Output Intent', the chosen **Destination Profile** will be used.

- **Set Document Profile:** A Document Profile is the color space of the process inks used in the document.



- **Always:** You can 'tag' a Normalized PDF file with its Document Profile. This means that the file knows what its Document Profile is, which can make color conversion further in the workflow more correct.

If you selected '**Use PDF Output Intent if available**', the Document Profile will be the same as the PDF Output intent (if the imported file had one).

- **From PDF File:** (available when '**Use PDF Output Intent**' is selected). The Document Profile is taken from the PDF file, if there is an output intent defined in the PDF file. If there is no Output Intent defined in the PDF file, then the Document Profile is not set (untagged).
- **Never:** The Document Profile is not set.

## Spot Colors

- **PANTONE Inks**

- **Keep all:** No PANTONE inks will be converted to process inks.
- **Convert all:** All PANTONE inks will be converted to process inks.
- **Keep list:** All PANTONE inks will be converted except for those listed in the tab [Inks](#).

### Method

- **Use destination profile:** PANTONE and Designer inks will be converted using the selected Destination Profile. This gives the most accurate color reproduction.
- **Pantone+ Color Bridge Coated:** Pantone inks will be converted to process inks according to a fixed conversion table provided by PANTONE. The result is independent of the selected Destination Profile.
- **Other Inks**
  - **Keep all:** No other spot color inks will be converted to process inks.
  - **Convert all:** All other spot color inks will be converted to process inks.
  - **Keep list:** All other spot color inks will be converted except those listed in the Inks tab.

## RGB

RGB will always be converted to process inks.

- **Convert:** Select a conversion method:
  - **Source to destination profile:** You here need to specify both the Source Profile (RGB) and the Destination Profile (CMYK or Grayscale).
  - **With link profile:** You here need to specify a 'Device Link Profile' created in Color Pilot. This link profile determines both the Source and Destination profiles.
- **Source Profile / Link Profile:** Select one from the list.
- **Objects with RGB Profile Tags:** RGB objects in a PostScript or PDF file may be tagged with a Color Profile.
  - **Ignore tag:** The embedded Color Profile will be ignored. The Source / Link Profile defined above will be used for the conversion of RGB objects.

- **Convert using profile tag:** The Color Profile is used as a Source Profile (overruling the Source / Link Profile selected above).

### CMYK and Gray

Objects in a PostScript or PDF file may be tagged with a Color Profile. The color percentages of untagged objects will always be preserved.

Both for **CMYK** and **Gray** tagged objects, you have a choice:

- **Ignore tags, preserve percentages:** The Color Profile tag will be ignored, the percentages will be those of the object's color.
- **Convert, preserve appearance:** The objects' color profile will be taken into account. This means that their color values will change.

### 6.145.3. Inks

Pages Color Management **Inks** Overprint Images Page size Other Output

Use rulings, angles and dot gain compensation from file if available

Force ink settings from Job setup

Apply Screen Swap Tab... <None>

Map PANTONE Inks to: Coated

Use ClassicColors ink book

Search Custom Ink Names:  Only in the ink book 'designer'

First in: and then in 'designer'

**Inks:**

<input checked="" type="checkbox"/>	Ink Name	Ink Book	Ruling	Angle	Dot Shape	Ink Type	Printing ...
<input checked="" type="checkbox"/>	Cyan	process	150 lpi	15 °		Normal	
<input checked="" type="checkbox"/>	Magenta	process	150 lpi	75 °		Normal	
<input checked="" type="checkbox"/>	Yellow	process	150 lpi	90 °		Normal	
<input checked="" type="checkbox"/>	Black	process	150 lpi	45 °		Normal	

Default values, used when a ruling, angle or dotshape is not specified:

Ruling: 150 lpi Angle: 45 ° Dotshape:

- **Use rulings, angles and dot gain compensation from file if available:**

When this option is selected:

- The angle, ruling and Esko dotshape are taken from the halftone specification in the PDF.
- If the PDF contains Esko XMP, the Ink Type and Printing Method are taken from this Esko XMP.

This option is mainly used for this case. PDF files containing Esko XMP are typically created by using the DeskPack plug-ins in Adobe Illustrator or by the AE task "Export to PDF File".

For inks that have information in the input file, the settings defined in this ink panel of the task or in the Job setup are not used.

- **Force ink settings from Job setup** : If inks were defined in your *Job setup*, you can use this toggle to make sure that this task uses those ink parameters.
- **Apply Screen Swap Table**: You can create 'screen swap' tables in the application 'ScreenFilter'. Select one to map PostScript screening to Esko screening.
- **Map PANTONE Inks to**: Select this to map all Pantone inks from the input file to a Pantone ink book of your choice. For example: to map `Pantone 123 U` to `Pantone 123 C`.
- **Use ClassicColors ink book**: When the input file has inks with names that also occur in the book 'ClassicColors' (for example "green"), select this option to map them to those in that ClassicColors book (in stead of becoming a 'designer' ink).
- **Search Custom Ink Names**: Define here the task should search for inks in its ink books when you type in an ink name in the Inks table.
  - Choose **Only in the ink book 'designer'** to search for ink names from the 'designer' ink book only.
  - Choose **First in <selected ink book> and then in 'designer'** to search in another ink book of your choice first, and only use the designer ink book if no match is found there.
- **Inks table**:
  - Double-click the fields in this table to edit them. The task will not change the inks that you here deselect.
  - **Default values, used when a ruling, angle or dotshape is not specified**: The task uses these default values when they are not specified elsewhere (for example in the PostScript file, in the Job setup, etc.).

### 6.145.4. Overprint



**Note:** This tab is only relevant when importing PostScript files.

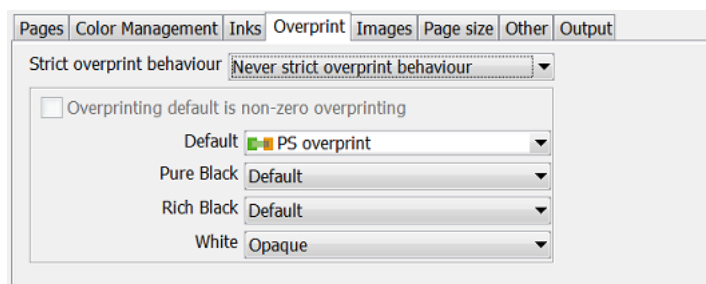

- **Strict overprint behavior**

When normalizing composite files, this option controls how zero percentage inks are handled.



**Attention:** This option *must* be used when you want to process test files like the Altona test suite or other test suites which verify correctness of overprint behavior.

When 'Strict Overprint' is used, all zero percentage inks of a color are kept and correspondingly affect the overprint behavior. Choose from:

- **Never strict overprint behavior:** All zero percentage inks are removed.
- **Always strict overprint behavior:** The task honors the overprint parameter 100% according to the rules mentioned in the "PostScript Language Reference" (in case of PostScript / EPS / AI import) and "PDF Reference Manual" (in case of PDF import).
- **Only strict overprint behavior for PDF:** The task honors the overprint parameter 100% according to the rules mentioned in the "PDF Reference Manual" (in case of PDF).

- **Overprinting default is non-zero overprinting**

Select this option to prevent overprinted objects with zero CMYK values from knocking out CMYK objects beneath them.

- **Default:** Choose the overprint mode that the conversion needs to apply.
  - **Opaque:** Ignores any overprint in your file.
  - **Darken (Esko):** Converts all overprint to Esko Overprint.
  - **PS Overprint:** All overprint in the file is imported as PS overprint. This is the default setting.

- **Pure Black**

Define the overprint mode for objects containing 100% black only. Possible Pure Black overprint modes in the list:

- **Default:** As it is defined in the file.
- **Force opaque:** Forces Opaque for objects in 100% black and knocking out all underlying inks.
- **Force PS overprint:** Forces PS overprint for objects in 100% black.
- **Force darken (Esko):** Forces the Esko darkening mode for all objects in 100% black. The black color is so printed on top of other colors, instead of erasing the color underneath.

- **Rich Black**

Define the paint mode for objects containing 100% black and at least one other ink.

- **Default:** As it is defined in the file.
- **Force opaque:** Sets the overprint mode to opaque for all objects containing 100% black and at least one other ink.
- **Force PS overprint:** Keeps the PS overprint for objects in 100% black and at least one other ink (overprint objects stay in overprint and opaque objects stay opaque).
- **Force darken (Esko):** Sets the Esko 'darken' overprint for all objects in 100% black and at least one other ink.

- **White**

Define how you want whites to be handled:

- **Keep PS overprint:** Keeps the PS overprint for objects in white (overprint objects stay in overprint, opaque objects stay opaque).
- **Opaque:** Forces all objects in white to opaque.

## 6.145.5. Images

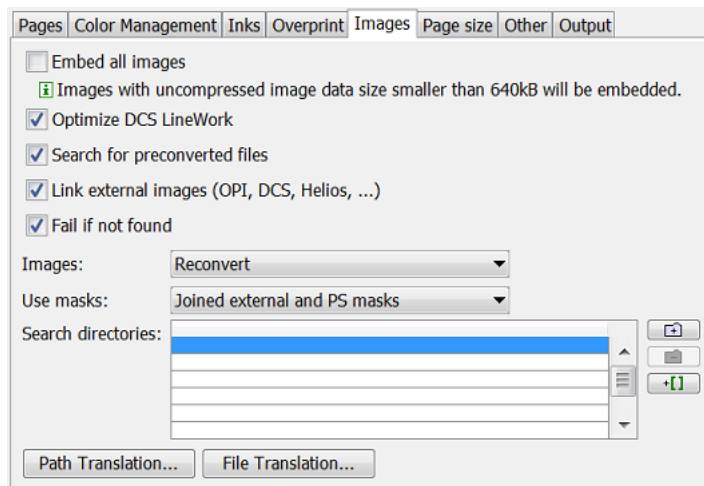

- **Embed all images:** Select this if you want to embed all 1-bit, 8-bit and native images into the output file. When not selected, only images with uncompressed image data smaller than 640 kB will be embedded.



**Note:** This is the only option in this tab that is relevant when normalizing PDF files.

- **Optimize DCS LineWork:** When DCS linework is not optimized, the result can be difficult to edit afterwards. However it will be correct when viewed in extended preview or RIP'ed. Select this option to trigger an additional operation that combines the elements on each DCS plate to a composite and a more editable result.
- **Search for preconverted Files:** This option forces the task to look for the CT, LP or GR\* equivalent for the original EPS file. If this equivalent is not found, it will use the EPS instead.
- **Link external images (OPI, DCS, Helios, ...):** This option forces the task to look for referenced images.
- **Fail if not Found:** Select this option if you do not want the task to continue when it cannot find an image. When not selected, the task will create an output file but one with missing images.
- **Images:** This option determines how images are treated when the task is run:
  - **Reconvert:** This forces the system to regenerate the images on-the-fly.
  - **Use most Recent:** This forces the system to use the existing images of a previous conversion of the same file.
- **Use masks**
  - **PS mask:** This forces the system to take the PostScript (PS) mask present in the EPF file. The mask available in the external image is discarded. If no PS mask is present in the file, no mask will be taken.
  - **External mask if any, PS mask otherwise:** This forces the system to take the mask present in the external image. The PS mask is discarded. When the external image has no mask, but there is a PS mask available in the EPF file, this PS mask will be taken.

- **External mask if any, no mask otherwise:** This forces the system to take the mask present in the external image. The PS mask is discarded. When the external image has no mask, no mask will be taken.
- **No masks:** The PS mask and the mask of the external image are discarded.
- **Joined external and PS mask:** This forces the system to join the available PS mask in the EPF file and the available mask in the external image.
- **Search directories:** You can here specify a list of directories where the system should look for referenced images.

Use the  'Add' and  'Remove' buttons to create this list.

- **Path Translation...:** This option serves to create a list that helps translating network paths from one platform to another. Click the button to open a dialog and define three columns:
  - **From platform:** Click on the field to select a platform from which the files are to be retrieved: (Windows) NT, Mac, Unix or VMS.
  - **From path:** Define the syntax of the path(s) of the platform you want to retrieve files from. For example `Mywork:BigCustomer:job1`.
  - **To path:** Define the syntax of the paths so that the destination platform understands. For example `Mywork/BigCustomer/job1`.

An example: when going from Mac to Windows NT, the path translation can look like this:

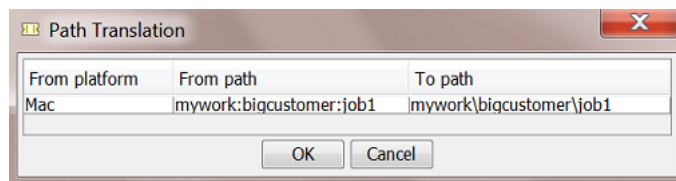

- **File Translation...:** The same kind of translation can be done for file names.

### 6.145.6. Page Size

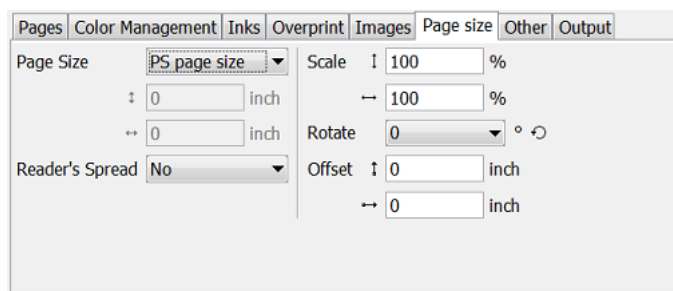

**Note:** The units are those defined in **Edit > Preferences > Units**.

- **Page Size:** Select the page size (Media Box) that you want for the output PDF file. Choose '**PS page size**' to keep the size of the input PostScript or PDF file.
- **Reader's Spread:** When the input file has a reader's spread format, choose from:
  - **No:** To force the reader's spread in the file into single page output.
  - **Yes:** To force the file into reader's spread format. When the file contains no reader's spread info, the single pages will be set as double pages.
- **Scale:** If you want, enter a vertical and/or horizontal scale.
- **Rotate:** If you want, choose a rotation. The origin for rotation is bottom left and the available rotations are counterclockwise.
- **Offset:** These fields allow to move the content of the file in regards to the page size. The anchor point for the offsets is bottom left. A positive offset moves the content of the file up and/or to the right. A negative one moves the content of the file down and/or to the left.

### 6.145.7. Other

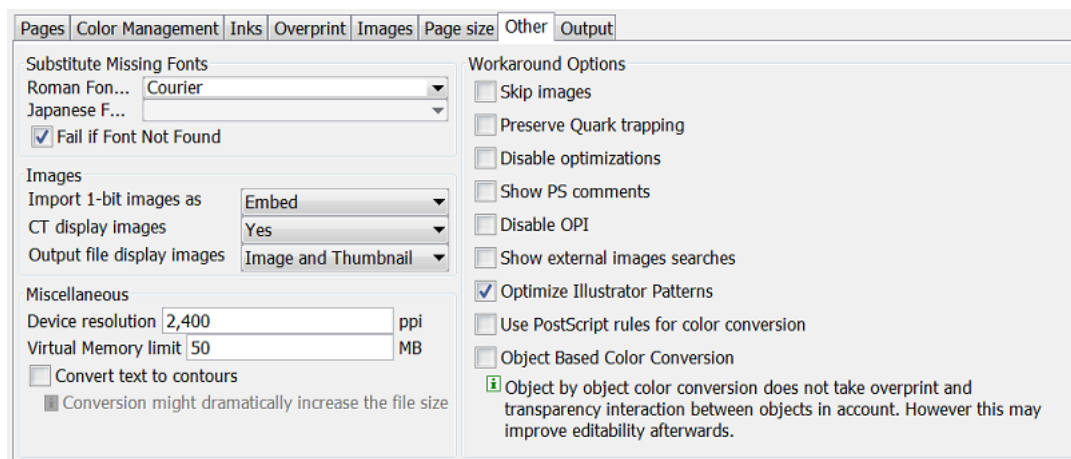

- **Substitute Missing Fonts**
  - **Roman Fonts by:** Choose a default replacement font for any missing Roman fonts.
  - **Japanese Fonts by:** Choose a default replacement font for any missing Japanese fonts.
  - **Fail if Font Not Found:** Select this to make the task fail when a font is not found.
- **Images**
  - **Import 1-bit images as:**
    - **Embed:** Images become internal black and white bitmaps.
    - **Linked file:** Images are imported as external referenced LP files (Esko native bitmap files).
    - **Contours:** Images are contourized during import.

- **CT display images:** Choose **Yes** to have the task also create a display image for the generated CT files.
- **Output file display images:** Select the type of display from the list: **None**, **Thumbnail** or **Image and Thumbnail**.
- **Miscellaneous**
  - **Device resolution:** The resolution that the task uses internally during normalization.  
Normally the produced output is not dependent of this internal resolution. However, in some rare cases, for example when converting RIP'ed test strips or device specific tests, it is important that this value is the same resolution as used on the RIP device that will be used to output.
  - **Virtual Memory limit:** The default value is 50 Mb. The maximum you can set is 1 gigabyte (1024 Mb).
  - **Convert text to contours.** Select this to convert all text to line work.
- **Workaround Options**
  - **Skip images:** Select this to import the (E)PS file without linking to external images or converting embedded images.
  - **Preserve Quark trapping:** Select this to force the task to keep the trapping strokes made by QuarkXpress.
  - **Disable optimizations:** When not selected, the task performs a recognition of vignettes and an optimization for Photoshop multitone images (whenever possible). Disabling such optimizations was useful when an older version of the task could not yet perform the optimization of the (E)PS file that a new DTP application had exported.
  - **Show PS comments:** When selected, all 'PS comments' present in the (E)PS file are mentioned in the task **Details** and in its **Log** file.
  - **Disable OPI:** This option is useful when importing QuarkXpress (E)PS files that contain high resolution Tiff files for which the option 'Include tiff, omit ...' or 'Include all' was activated.  
  
When importing such a file, and if **Link External Images** is selected, the matching of the TIFF files will surely fail. It fails because at the time the (E)PS file was generated, OPI commands were also inserted for the TIFF files. Therefore the system will try to link to images for the Tiff files. To overcome this, select this option.
  - **Show external images searches:** Select this to see, in the task's log file, the path(s) where the task finds and links to external images.
  - **Optimize Illustrator Patterns:** Adobe Illustrator writes patterns in a different way than PostScript does. This option normally results in less linework in the output file, which then speeds up the further processing. However, sometimes the optimization itself may take some time.
  - **Use PostScript rules for color conversion:** Select this to make sure that all color management will happen using PostScript rules, instead of Esko's BGCMS. Selecting this option grays out most options in the [Color Management tab](#).



- **Object Based Color Conversion:** 'Object by object' color conversion does not take overprint and transparency interaction between objects into account, and may therefore produce undesirable results. However, it may greatly improve editability.

### 6.145.8. Output

- **Keep Layers.** Select this to keep the input file's layer information. This works for Illustrator 8 files (not v9 nor higher) and for PDF 1.5 or higher.
- **Fit Media Box (margins).** Select this to automatically fit the margins.
- **Image Directory.** When the task creates new image data, you can here indicate where these images should be written.

The default offered SmartName [Job CT URL] will create them in a 'CT' folder that is created in the root of the input file's Job Folder. Leave the field empty to have the image files written next to your output file. Or select your own (central) folder and possibly add SmartNames to that path.

## 6.146. Normalize TIFF/IT File (Classic)

---

This old technology is still supported but no longer commercially available.

Please find its documentation in the [manual of Automation Engine 14.1 or older](#) (as part of the Reference Guide).

## 6.147. Optimize and Clean (PSFix) (Classic)

---

PSFix is an old Esko technology that optimizes and cleans files that were imported from PS or PDF files. A typical feature is the removing of redundant objects. The resulting file is easier to edit and process.

This task is typically executed right after a conversion to Normalized PDF.

### 6.147.1. General

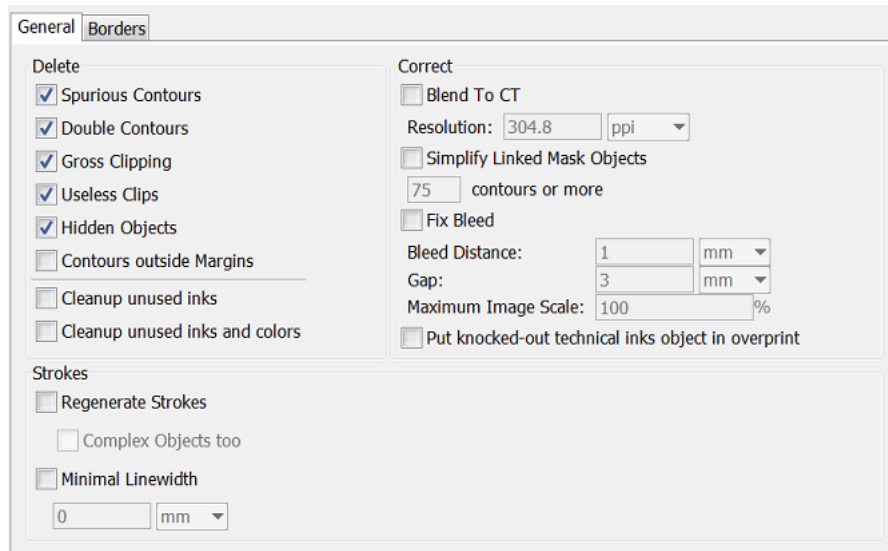

- **Delete**
  - **Spurious Contours:** These are
    - Single points that only have a fill attribute.
    - Single points that have a stroke attribute with butt or square caps.
    - Contours that contain two points and that have a mask attribute, but do not mask out any object. These contours can be created by accident or generated by PostScript printer drivers.
  - **Double Contours:** This removes double contours by recombining the fill and stroke attribute of two identical objects into one object again. Double contours are created when importing PostScript files, in which case an object with a fill and a stroke attribute is split into two objects with each one attribute.
  - **Gross Clipping:** This deletes the objects whose bounding boxes fall completely outside the bounding box of the clipping path. This also works on composed text and externally referenced objects.
  - **Useless Clips:** This deletes useless clipping paths, objects that are totally clipped away or objects that are totally covered by other objects.
  - **Hidden Objects:** This deletes objects that are completely covered with another object. The designer did not want to delete them or could not delete them on a certain page, as they may have been components of a master page.
  - **Contours outside margins:** This deletes contours outside the margins.
  - **Clean up unused inks:** This removes all unused inks from the list of inks (separations).
  - **Clean up unused inks and colors:** This removes all unused inks and also unused colors (items in the color palette of the editing application).
- **Strokes**
  - **Regenerate Strokes:** This searches objects that contain 20 points or less and converts them to the equivalent strokes.

Select '**Complex Objects too**' if you want the task to search all objects that might be degenerated strokes, so also those with more than 20 points.

- **Minimal Linewidth:** This defines the minimal width of strokes.
- **Correct**
- **Blend to CT:** This converts all blends to externally referenced CT images at a defined **Resolution** (1 image per blend).

In PostScript files, blends are constructed by a large amount of contours that lie close to each other and that have slightly different colors. The more accurate the blend, the more contours and colors it is made of. This leads to large file sizes and decreases the processing speed.



**Note:** After this conversion, the display of the blend can be different. However, the conversion does not affect the printed result.

- **Simplify Linked Mask Objects:** This tries to reduce the number of linked contours for complex mask objects. This option is only useful for linked mask objects with a large number of contours (>50).

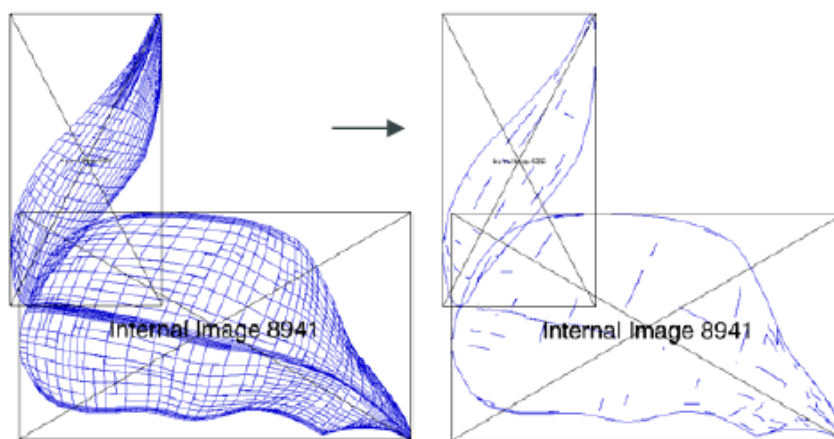

- **Fix bleed:** This task can automatically create bleed. Bleeds for linework objects are created in a new layer called "**Bleedlayer**". This layer can always be removed to return to the original file. This is not possible with images. Images are modified in their original location.
  - **Bleed Distance:** This is the minimal amount of bleed that is required. For any object that does not have this amount of bleed the correct bleed will be created.
  - **Gap:** Any object inside the 'borders' (Trim Box), and that is closer than this distance to the borders will be considered to require bleed. Typically, this value will be small. It makes sure that objects which do not really touch the borders because of inaccuracies in the design, are taken into account for bleed creation anyhow.
  - **Maximum Image Scale:** There are two possible to fix bleed for images:
    - When an image is larger than its clip mask, the task creates bleed by extending the clip mask of the image. Hidden pixels so become visible and the missing bleed problem is fixed.
    - When the image is not larger than its clip mask, the only way in which bleed can be created is by scaling the image. The position of the image inside the page does not

change, but it is disproportionately scaled to create the correct bleed. To avoid an unacceptable distortion of the image this parameter determines how much scaling of an image is allowed. Set the value to 0 to prevent any scaling.

In order for the bleed-fixing to work properly it is imperative that the borders of the file are set correctly (see the tab *Borders* on page 398).

- **Put knocked-out technical inks object in overprint:** This forces objects in technical inks in overprint mode.

### 6.147.2. Borders

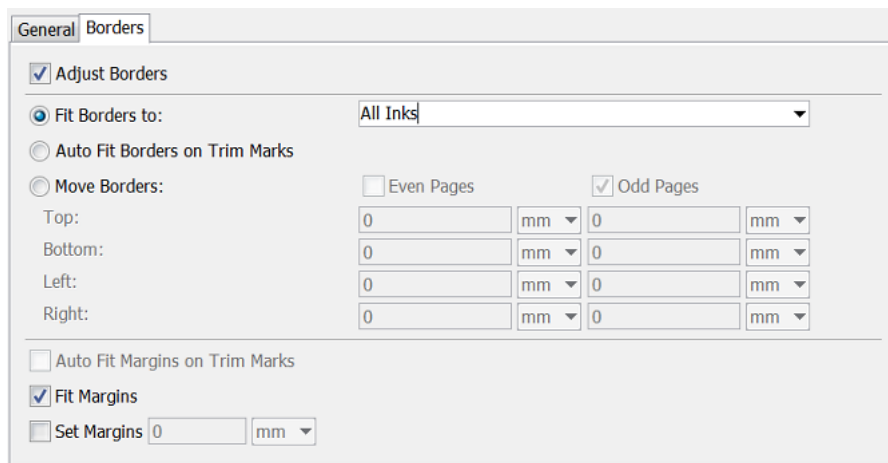

- **Adjust Borders:** Select this to enable these options:
  - **Fit borders to:** Choose **All inks** or one from your input file (for example its ink 'CAD'). For a multi-page file, when borders need to fit to a specified ink, the borders will be adjusted to the largest page.
  - **Auto Fit Borders on Trim Marks:** When the task can detect trim marks, the borders will be set accordingly. For a multi-page file, when borders are fitted to trim marks, the borders will be adjusted to the first page.



**Note:** The task recognizes trim marks that have an offset of at least 1 mm and have a length of at least 1 mm.

This option is useful when the trim size of the input file is unknown or unreliable (for example a missing or wrongly defined trim box in a PDF file). Even when the desired trim size is known to the user, it can still be interesting to see if the automatically determined border size corresponds to the desired one: a difference between the two is likely to point to an error.

Note that the intelligent placement of files in FastImpose and Plato allows users to neglect to work with accurately set borders. However, if you want to *fix wrong bleeds* it is a requirement to have the borders defined correctly.

- **Move Borders:** You can manually move any of the borders for **Even** and/or **Odd** pages.
- **Auto Fit Margins on Trim Marks:** To fit the Media Box to any trim marks.
- **Fit Margins:** To fit the Media Box to any objects in the file.

- **Set Margins:** To define a specific value for the Media Box.

## 6.148. Optimize PDF Document (Classic)

---

This task enables you to make some prepress-specific changes to a PDF document. It so avoids having to stop a workflow task to do such edits in an interactive application.

The output will be PDF when the input file is a native PDF. The output will be Normalized PDF when the input is a Normalized PDF or a PDFPLA file.

### 6.148.1. Document

- **Optimize Document**

- **Preserve fonts:** Select this make sure your fonts will print or display correctly. Choose a method:
  - **Embed Fonts:** This embeds all used fonts.
  - **Embed & Rename:** This embeds 'Base 14 Fonts' under a different name (their name in the Esko PDF Library), and all other fonts under their existing name. This prevents Acrobat from replacing the document font with a local font of the same name when using live text.



**Note:** 'Base 14 Fonts' are: Courier, Courier Bold, Courier Oblique, Courier Bold-Oblique, Helvetica, Helvetica Bold, Helvetica Oblique, Helvetica Bold-Oblique, Times Roman, Times Bold, Times Italic, Times Bold-Italic, Symbol and Zapf Dingbats.

- **Vectorize:** This converts all text to outlines.
- **Apply document's rotation flags:** In a PDF file, a 'rotation flag' specifies by what angle the contents should be rotated when previewing or printing the file.

Some older applications and devices ignore or mishandle this rotation flag. If you are sending your file to such an application or device, select this option to execute the rotation specified in the rotation flag.
- **Outline strokes:** Select this to convert the strokes to outlines. Choose **Dash Only** to only converts dashed strokes into individual outline objects. This can significantly improve trapping.
- If you want to change the strokes' width in your document, select **Increase line width** and enter a **Minimum Line Width**. All strokes with widths below this value will be enlarged to that width.
- **Rotate File:** Select this to rotate the contents of your file (clockwise). This may be needed to make the contents fit on a certain device.
  - If **Apply document's rotation flags** is not selected, this changes the rotation flag's value but does not rotate the file's contents.
  - If **Apply document's rotation flags** is selected, this rotates the file's contents.
- **Adjust Page Box:** Use this to change some or all of the document's page boxes, or add page boxes in your document. Learn more in [Adjust Page Box](#) on page 400.
- **Outline Page Box:** Use this to outline some or all of the document's page boxes. They then become visible on proof for example. Learn more in [Outline Page Box](#) on page 401.

## Adjust Page Box

To add or change a page box:

1. Click **Add** to open the **Adjust Page Box** dialog.

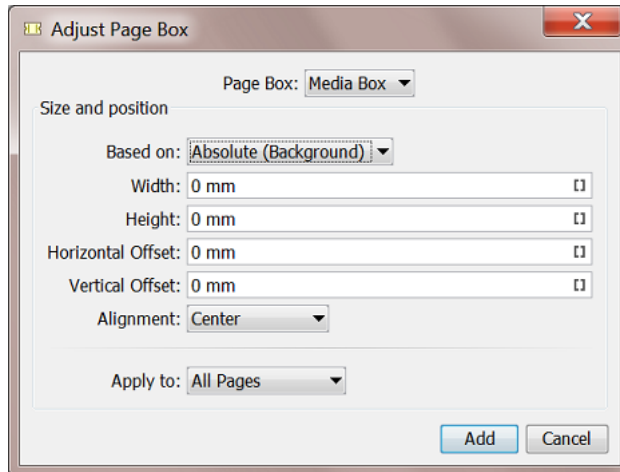

2. Select the **Page Box** to add or change.
3. Choose what you want the new size to be **Based on**:
  - Choose **Absolute (Background)** if you want to define the page box size independently of the file's contents or existing page boxes.
  - Choose **Content** if you want to base the page box size on the file's contents. This takes clipping paths and masks into account.
  - Choose **Media Box, Crop Box, Trim Box, Bleed Box** or **Art Box** if you want to base the size of the selected page box on that of another one.
4. Define the new **Width** and **Height**.
  - If you have chosen to use an **Absolute** size, enter the page box's **Width** and **Height**.
  - If you have chosen to base the page box size on the file's **Content** or on another page box, you can adjust the width and height in **Increase Width** and **Increase Height**.



**Note:** Use a negative value to reduce the page box size instead of extending it.

5. If you want, enter an **Horizontal Offset** and / or a **Vertical Offset**.
  - A positive horizontal offset will move the page box to the right, a negative one to the left.
  - A positive vertical offset will move the page box to the top, a negative one to the bottom.



**Note:** This is applied after the **Alignment** was done!

6. Choose the page box's **Alignment** (relatively to the old page box):

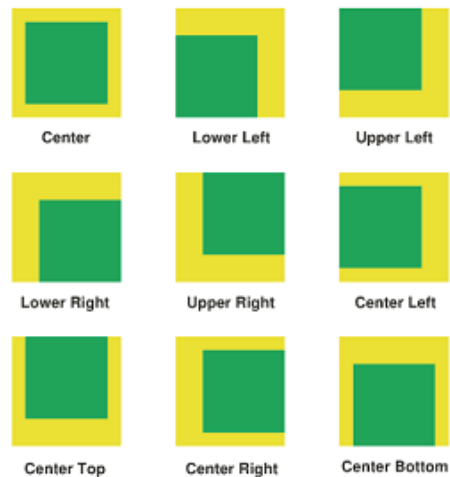

7. Apply your changes to either **All Pages** or only to the **Odd** or **Even Pages**.
8. Click the **Add** button to confirm.



**Note:** You can adjust multiple **Page Boxes**.

### Outline Page Box

To outline a page box:

1. Click **Add** to open the **Outline Page Box** dialog.

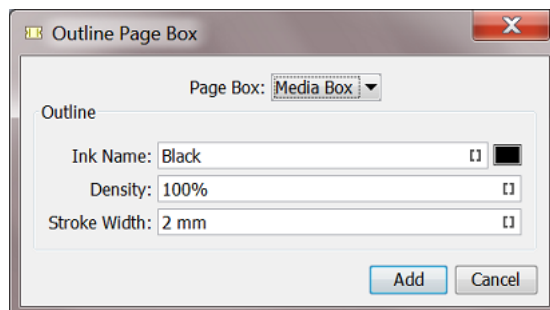

2. Select the **Page Box** to outline.
3. Define the **Ink** for the stroke to use.  
Type an **Ink Name**, use a SmartName or click the color patch to open a color picker.
4. Enter the ink **Density** to use.
5. Specify the **Stroke Width** to use.
6. Click the **Add** button.

## 6.148.2. Layers

- **Action 1: Rename Layers**

Click **Add** and enter the **Old** and the **New Layer Name**. You can use SmartNames and / or wild cards (to replace part of the layer name).



**Tip:** You can also merge layers by renaming a layer to an existing layer's name, or by renaming several layers to the same name. This works for layers that are directly on top of each other in the file.

- **Action 2: Remove Layers**

Click **Add** and enter the names of the layers you want to remove. You can use SmartNames and / or wild cards.

**Except for:** When using a wild card to remove layers, use this parameter to keep certain layers, even if they match the name entered in **Remove Layers**.

- **Action 3: Add Layers**

Use this to add empty layers to all pages of your PDF.

Click **Add** and enter the name of the layer to add. Repeat as necessary.

- **Update Layer Print-ability:** Select how to handle the print-ability of layers in your output file:
  - **Don't Change Layer Print-ability**
  - **Make All Layers Printable**
  - **Remove Non Printable Layers.**

### 6.148.3. Images

- **Downsample Images**

Select this to lower the resolution of the file's images.

- Choose what resolution you want to **Downsample bitmap** (black & white or one-bit) **images to, if their resolution is above** a certain resolution.
- Choose what resolution you want to **Downsample contone** (grayscale or color) **images to, if their resolution is above** a certain resolution.



- **Crop Images**

The tasks can remove unused image data from the PDF by cropping images on the bounding box of their clip path. Cropping images is done to make PDFs smaller.

**Split images area when at least ... % of the images is clipped away:** This parameter defines how the task will crop the image, depending on how much of it is clipped away (for example for images that have multiple clipping paths on them).

- If the part of the images that is clipped away is less than the value you enter here, the images will stay together and be cropped to the bounding box of the combined clipping paths.
- If the part of the images that is clipped away is greater than the value you enter here, the images will be split into multiple clipped images, each cropped to the rectangular bounding box of its clipping path.

- **Recompress Image Data**

- For **Color, Gray Scale** and **Soft Mask Images**, you can choose between the **JPEG** and **ZIP** compressions.
- For **Bitmap Images**, you can choose between the **CCITT Group 3, CCITT Group 4, ZIP**, and **Run Length** compressions.

## 6.149. Optimize PDF Separations (Classic)

---

This task enables you to make changes to the separations of a PDF file.

The output file will be PDF when the input file is a native PDF. The output file will be Normalized PDF when the input file is a Normalized PDF or a PDFPLA.

When the input is a multi-page file, all requested functionality is executed on all pages.

### 6.149.1. Colors

You here define how to convert the file's (non-process) colors.



**Note:** The conversion is done by Esko color engine.

- **Embed Profiles Mode:** The task uses embedded profile(s) as source profiles for conversions. Choose from:
  - **Do not change:** This doesn't make any changes to embedding of color profiles.
  - **Embed:** This embeds all color profiles.
  - **Embed & Overwrite:** This re-embeds all color profiles, overwriting profiles that were already embedded.
  - **Remove All Embedded:** This removes all embedded profiles.
- **Convert RGB, LAB, Gray to CMYK:** Select this to convert all non-process color spaces (except spot colors) to CMYK.



**Note:** This will generate errors and/or warnings when trying to convert non-separable blend modes.

- **Fail When Converting Color Spaces:** Color converting objects that have transparency effects (like blend modes) can generate visually unexpected results. When this problem occurs, you can:
  - Select this option if you want the task to stop with an error.
  - Deselect this option if you want the task to only generate a warning.
- **Default CMYK Profile:** Select the default profile to use for CMYK objects without an embedded color profile. It will be used as a source profile for Color Space conversions.



**Note:** You can choose any CMYK profile in the color engine database.

- **Default RGB Profile:** Select the default profile to use for RGB objects without an embedded color profile. It will be used as a source profile for Color Space conversions.



**Note:** You can choose any RGB profile in the color engine database.

- **Default Gray Profile:** Select the default profile to use for gray-scale objects without an embedded color profile. It will be used as a source profile for Color Space conversions. Choose from:
  - Any gray profile in the Color Engine database.
  - **Convert to Black Channel**, if you want your gray-scale object to only have a value in the Black separation when outputting it to CMYK.
- **Output Color Profile:** Enter the Color Space of the output device (proofer or press) in this parameter.



**Note:** You can choose any CMYK profile in the color engine database.

- **Update spot color equivalents:** This option handles CMYK values for spot color inks. You can:
  - Select this option to overwrite the CMYK values found in the file with the CMYK values stored in the ink book.
  - Deselect this option to use the CMYK values for spot color inks found in the file.
- **Spot Color Lookup:** Indicate where the task should look for the spot colors' information. Choose from:
  - **Look in Ink Books First:** The task first looks in the ink book you defined in **Preferred Ink Book**. If it doesn't find the spot colors' information in that ink book, it then looks for it in the file.
  - **Look in Ink Books Only:** The task only looks in the ink book defined in **Preferred Ink Book**. If the task does not find the spot colors' information in that ink book, it ends in error.
  - **Use Colors in File:** The task looks for the spot colors' alternate color values (generally in the CMYK color space) in the file, and uses those values.
- **Preferred Ink Book:** Choose the preferred ink book that will be used in this task.
- **PANTONE Color Lookup:** Choose the settings for the PANTONE colors conversion. Choose from:
  - **Use destination profile:** Use the color profile defined in the **Output Color Profile** to determine CMYK equivalents of the PANTONE Color.
  - **HP Indigo CMYK x.x:** Use CMYK equivalents for the HP Indigo Press.

- **Pantone+ Color Bridge Coated:** Use the CMYK equivalents defined in the Pantone Color Bridge Coated guide.

## 6.149.2. Inks



**Note:** This functionality is executed in the order as numbered: First **Action 1**, then **Action 2**, etc.



**Warning:** All ink-related parameters are case sensitive.

- **Action 1: Remap Inks**

Click **Add** to open the **Remap Ink** dialog, then enter the **Old** and the **New Ink Name**.



**Tip:** You can also merge inks by remapping an ink to an existing ink's name, or by remapping several inks to the same name.



**Note:** If your original ink has a PANTONE Suffix, add it to the **Old Ink Name**, even if you are changing this suffix. The reason for this is that when you use both the **Remap Inks** and **Pantone Suffix** parameters, the task renames the inks first.

**Pantone Suffix:** Use this to change the suffix (for example CV, CVC, CU...) of PANTONE colors. Choose from:

- **Do not change.**
- **Convert:** This changes the suffix to the one you select in the **To** list, for all PANTONE colors.
- **Convert If Found In Ink Books:** This changes the suffix to the one you select in the **To** list, for PANTONE colors found in the ink books you defined (in the [tab 'Colors'](#)).



**Note:** This option can also merge inks. For example if you have PANTONE 484 U and PANTONE 484 C, and you change all the suffixes to C.

- **Action 2: Convert Inks**

Use this table to convert spot colors to CMYK. You can use wild cards (\*) in the ink's name.

- **Action 3: Remove Inks**

Click **Add** and enter the names of the ink you want to remove. You can use SmartNames and/or wild cards.

**Except for:** When using a wild card to remove inks, use this parameter to keep certain inks, even if they match the name entered in **Remove Inks**.

For example, to create a PDF file for the die-cutter, you can remove all the inks except the ink `Die cut` :

Action 3: Remove Inks

*
Add Remove

Except for:

Die cut
Add Remove

**Preserve Separation Interaction:** Use this parameter to define what to do when the separations you remove contain objects that knock out other separations.

- **None:** This only deletes knock-out objects that are only defined in the removed separation(s).  
Use this when removing separations that don't influence the final result (for example die cut separations).
- **Standalone:** This converts knock-out objects that are only defined in the removed separation(s) to white knock-out objects defined in one of the remaining separations. The remaining separations keep looking the same.

This method is recommended for most use cases.

- **For Versioning:** This converts knock-out objects that are only defined in the removed separations to white overprinting objects. Those are defined in a color space made from the remaining separations of the file, and overprinting on all other separations.

This ensures that when re-adding separation layers for versioning, the final result looks the same as the original file.



**Note:** This may create objects in 'DeviceN' color spaces, which is something that some applications cannot handle. Only use this method if you want to do versioning on your file.

- **Remove unused separations:** Select this to remove unused separations (separations containing no objects) from the file.

### 6.149.3. Ink Properties

This tab allows to apply extra properties of **Ink Type** and **Printing Method** to the existing inks. These properties can be used to steer behavior of tasks later on in the workflow, for example when using the [Extract Inks \(Classic\) task](#) based on printing methods.

Colors
Inks
Ink Properties
Overprint

**Apply Ink Type**

Ink Name	Ink Type
DieCut	Technical
High Gloss	Varnish

Add
Remove

**Apply Printing Method**

Ink Name ^	Printing Method
PANTONE Process Yellow C	Screen

Add
Remove

- **Apply Ink Type**

You can define the **Ink Type** for each **Ink Name**. You can use SmartNames and wild cards.

An **Ink Type** can be **Normal**, **Opaque**, **Varnish** or **Technical**. Limitations for **Opaque** can be imposed by the CMS. Process colors (CMYK) can only be **Normal**.



**Note:**

- When using wild cards in the ink name, the inks matching that pattern will get the specified properties. If an ink matches more than one pattern, the first one is taken.
- When matching, the letter case is ignored.

- **Apply Printing Method**

Set the **Printing Method** for a specified **Ink Name**. Choose from the list of printing methods as defined [in the Configure panel](#).

## 6.149.4. Overprints

Use these options to change the Overprint versus Knockout behavior of the inks.

- **To Knockout**

- **All overprint objects:** Select this to disable all overprints in your file.



**Attention:** This can change the file's appearance.

- **White text:** Use this to set white text to knockout. In this context, 'white' means having a fill or stroke of 0% of one or more inks.
- **White vector:** Use this to set white line art to knockout. 'White' here context means having a fill or stroke of 0% of one or more inks.
- **Technical objects:** Use this to set technical objects to knockout.
- **Varnish objects:** Use this to set varnish objects to knockout.
- **Opaque ink vector:** Use this to set line art in opaque ink to knockout. Opaque inks are defined in the ink book, using the Color Pilot.
- **Opaque ink text:** Use this to set text in opaque ink to knockout. Opaque inks are defined in the ink book.



**Attention:** When an ink is explicitly defined as "opaque" in the ink book, you cannot make it "normal" with this task. You will get a warning if you try.

- **To Overprint**

- **All knockout objects:** This parameter changes all knockout objects to overprinting objects, and modifies their color space(s), so that the file keeps the same appearance.



**Attention:**

- Only use this parameter in creating PDF versions.
- This parameter affects how you can place the file afterwards. If you place this overprinting file on top of another file, all the channels of the bottom file that are not present in the top file will be visible.

- **Black text:** Use this to set black text to overprint. You can choose to make:
  - **All** black text overprint, or
  - black text **Smaller Than** a defined value overprint.
- **Black vector:** Use this to set black line art to overprint.
- **Technical objects:** Use this to set technical objects to overprint.
- **Varnish objects:** Use this to set varnish objects to overprint.
- **Opaque ink vector:** Use this to set line art in opaque ink to overprint. Opaque inks are defined in the ink book.
- **Opaque ink text:** Use this to set text in opaque ink to overprint. Opaque inks are defined in the ink book.

## 6.150. Optimize PDF

---

### Concept

In ArtPro+, next to editing the open file, the user can also create a list of actions to be executed, i.e. an Action List. He can execute this action list interactively - in the editor itself - or he can execute that action list in background, as a task on AE. That task is the task [Apply PDF Action List](#).

This task 'Optimize PDF' is different. It avoids that someone first has to create an Action List.

This 'Optimize PDF' task allows to combine many of those actions and then execute them in background. You define all the wanted actions in the ticket and then launch it.

**To use this 'Optimize PDF' task, you do not have to create an Action List.**

Every time you launch an Optimize PDF ticket, AE first creates, hidden in background, a temporary Action List for this task.

To do this, AE uses the PAL processor, a technology that wrapped the ArtPro+/NDL kernel into a version that AE can then use in background. Learn more about the PAL Processor in [Which AE task Uses which Technology?](#) on page 66.

### General Behavior

- The Esko editor ArtPro+ reads and writes PDF+ files. Learn more about PDF+ in [PDF+ in Automation Engine](#) on page 52.
- **Input and output files:**

- When the input is a regular PDF file, the output is a PDF+ file.
  - When the input file doesn't have a document profile, a profile will be embedded in the output file. This ICC profile is defined in the **Configure tool > Processing Preferences > PDF+ Processing**.
- When the input is a normalized PDF file or an ArtPro (.ap) file, the output is a normalized PDF file.
- **Multi-page:** When the input file has multiple pages, the actions are applied on all pages.
- **SmartNames:** Mind these rules when using SmartNames:
  - When the input field represents a distance, the SmartName value needs to end with a unit (*in, mm, cm, dm, mil, pt*).
  - When the input field represents a density (for example when outlining a page box), the SmartName value needs to either represent a fraction (between 0 and 1) or a percentage value (and then also end with '%').
- **Order of execution:** The actions are applied in the order as you see them in the ticket:
  - The order of the tabs listed on the left.
  - Within each tab: top to bottom.
  - When multiple settings in one action: also top to bottom, except when stated otherwise (see the 'Remove' actions).
- In a ticket, tabs where any kind of action is selected are indicated with a check mark:

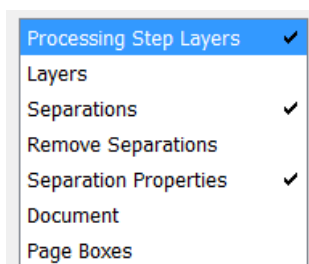

- **Marks:** When the input file contains live PDF marks, they will be updated to reflect the updated state of the document (layers, separations, page boxes).



**Attention:** Any SmartMarks from a normalized PDF input file will not be updated by this task.

- **Unused Separations:**
  - When a normalized PDF file contains unused separations, they will be removed from the output.
  - In a PDF+ file, unused separations can not be removed (nor can their order be changed).

### 6.150.1. Tab 'Preprocessing'

- **Expand placed art:** By default, you do not need to select this option to have the task modify the content of placed art objects. The task will, when it detects it is required to modify objects in that placed art, unlink it and embed it first.

Selecting this option is exceptional. When selected, the task will embed all placed art into the PDF itself. Linked placed arts will be unlinked. You may select this option if you were using it in a version before AE 23.11 and you want to keep the same effect.



**Note:** Since AE 23.11, this 'Optimize PDF' task can - contrary to interactive work in ArtPro+, also make changes in placed art.



**Tip:** The difference between 'embedded' and 'expanded' art:

- **Embedded:** The art (PDF) is placed as one object into another PDF, among other objects. The main document knows the separations of the embedded art and their properties but knows nothing about the structure (objects, layers) inside the embedded art (PDF). In that sense, you could compare it to an image.
- **Expanded:** The objects from the placed art (PDF) are transferred into the main document and will use its inks like other objects. Their layers become sub-layers of the original object layer (in ArtPro+ and AE ; other editors could loose or keep some information differently). Warning: When expanded, structural design objects and warp grids become normal lines and lose their original functionality.



**Note:** When this task needs to execute 'Document Cleanup' actions, there will be no warning when you did not select this option

- **Expand marks:** Select this to expand all Dynamic marks. When not selected, this task will update the marks.
- **Expand barcodes:** When not selected, the task will update Dynamic barcodes.

## 6.150.2. Tab 'Color Management'

Define here how you want the task to handle ICC color profiles.

- **Objects with Profile Tags:**
  - **Keep profile tags:** Select this to keep color profile tags attached to objects inside the document. This is the default option. (SmartName value = *keep*).
  - **Remove profile tags:** Select this to remove color profile tags from objects in the document. (SmartName value = *discard*)
  - **Convert using profile tags:** Select this to convert object colors towards the document output intent. Original profile tags will be removed. (SmartName value = *apply*).
- **Update spot color CMYK equivalents:** This option handles CMYK values for spot color inks.
  - Deselect this option to use the CMYK values for spot color inks as found in the file.
  - Select this option to overwrite the CMYK values found in the file with the CMYK values stored in an ink book.
- **Spot Color Lookup:** Where should the task find the spot colors' CMYK equivalent? Choose from:
  - **Look in Ink Books First:** The task first looks in the ink book you select below in **Preferred Ink Book**.  
If it doesn't find the spot colors' information in that ink book, it will look further in other ink books and when nothing is found there it will finally look in the file.



- **Look in Ink Books Only:** The task looks in the ink book selected in **Preferred Ink Book**.  
If the task does not find the spot colors' information in that ink book, it checks further in other ink books. If the task does not find the spot colors' information in any ink book, it ends in error.
- **Use Colors in File:** The task looks for the spot colors' alternate color values (generally in the CMYK color space) in the file, and uses those values.
- **Preferred Ink Book:** Select the preferred ink book that will be used in this task.
- **PANTONE Color Lookup:** Choose the settings for the PANTONE colors conversion. Choose from:
  - **Use destination profile:** Use the color profile defined in the **Output Color Profile** to determine CMYK equivalents of the PANTONE Color.
  - **HP Indigo CMYK x.x:** Use CMYK equivalents for the HP Indigo Press.
  - **Pantone+ Color Bridge Coated:** Use the CMYK equivalents defined in the Pantone Color Bridge Coated guide.

### 6.150.3. Tab 'Processing Step Layers'

#### About Processing Steps

- **What is a Processing Step?**

"Processing Steps" is a methodology to store PDF objects in a PDF that will be used for additional processing beyond the step of printing, for example embossing, gluing, cutting, folding, etc.

Learn more in the pages [PDF+, Successor of Normalized PDF](#) on page 52, [PDF+ File's Info Dialog](#) (the section on layers) and [Processing Steps - Groups and Types](#) on page 64.

- **Why use Processing Steps?**

- Because this information in the PDF can improve your workflow. This of course relies on applications and devices that pick up this type of PDF object.
- Giving layers the attribute of a type of processing step (for example the type 'embossing') enables to no longer use the attributes 'technical' and 'varnish' that you could set for 'Inks'. Those extra ink-type attributes are Esko proprietary attributes restricted to use in normalized PDF. PDF+ enables to skip using those and instead use this ISO conform way to use layers for this purpose.

#### Set Processing Step Type for Layer

- **Setting a Layer to the Type 'Processing Step'**

- Defining the name of the layer:
  - Either type the name or select it from the list of layers of the input file.
  - Layer names can contain wildcards (\*) and SmartNames. It can be a comma separated list of layer names.
  - The matching to layer names is not case sensitive. For example: the layer 'tech' will also match to 'Tech'.

- Defining the type of processing step: The matching layer(s) will be set to the type of processing step that you selected from the list.



**Attention:** In case you use a SmartName in this field or type in a value, be aware that this field is case sensitive!



**Note:** The types in the list are those defined in the ISO standard. You can not define custom ones.

- The task also moves this type of layer(s) on top of all artwork layers.

- **Removing the processing step type from a layer**

When you set the field for 'processing step type' to 'None' (not case sensitive) or you leave it empty, then the layer(s) will be converted into normal layers (i.e. the processing step type is removed).

In this case, the layer order does not change.

### Create Processing Step Layer from Separation

You can also create such a type of layer by using the data present in a specific separation.

- **Separation Name:** The objects that have a fill or a stroke in that separation (not case sensitive) are moved to this layer. These objects are also set to overprint.
- **Layer Name:** The specified layer (case sensitive) will be moved on top of all artwork layers. When that layer doesn't exist yet, it will be created.
- **Processing Step Type:** The specified layer will be set to the specified type.

## 6.150.4. Tab 'Layers'



**Note:** About defining the name of the layer:

- Either type the name or select it from the list of layers of the input file.
- Layer names can contain wildcards (\*) and SmartNames. It can be a comma separated list of layer names.
- The matching to layer names is not case sensitive. For example: The layer 'tech' will also match to 'Tech'.

### Rename Layers

Select or define the name of the old layer and then define its new name it should get.

### Remove Layers

Specify the layers that need to be removed from the input file.

- **by Name**
- **by Processing Step**

### Keep Layers

Specify the layers that were defined in the list of **Remove Layers** but that should not be removed.

- **by Name**
- **by Processing Step**

### Add Layers

This allows to add empty layers. They are added on top of the other artwork layers.

- A comma separated list of names is here not supported (it will be seen as one name with comma's in it).
- The layer will not be added when the input file already contains a layer with the same name.
  - Exception: The name matching is case sensitive, i.e. the layer is still added when the input file contains a layer with a name that only differs in case from the specified name. Example: you can add a layer 'side' when there is already a layer 'Side'.

### Update Layer Printability

Learn more about the printability of layers in the [ArtPro+ user guide](#) (Document Settings > Layers).

- **Don't Change Layer Printability:** This (default) setting does not make any changes. This is useful when you want to keep the non-printable layers. For example layers that contain base information that is used for aligning or editing.
- **Make All Layers Printable**
- **Remove Non Printable Layers:** This removes all non printable layers and their objects.

## 6.150.5. Tab 'Separations'



**Note:** About defining the name of the separation:

- Either type the name or select it from the list of separations of the input file.
- Separation names can contain wildcards (\*) and SmartNames. You can also define a comma separated list of separation names.
- The matching of a separation name is not case sensitive (ignores the case). For example: typing 'gold' will also match with 'Gold'.

- **Remap Separations**

- **Old and New Separation Name:**

Define the name of the separation to be renamed (old name) and its new name.

- When the new separation does not exist yet, it will be created (and listed at the end of the separation list).
- When the requested new name is the name of a separation that already existed in earlier versions of that file, it will be positioned in the order it used be in before.



**Note:** This memory of separation names that disappeared in later versions of a PDF is the result of a safety logic to make sure that all pages of a PDF have and keep the same order of separations.

- **New Separation Book:** Optionally, you can select the ink book of the target separation from the list.
  - When using a SmartName or typing in a name, there is no check if that ink book exists.
- You can remap multiple inks:
  - By using wildcards. For example, rename 'PMS\*' to 'HKS\*'.
    - By using comma separated lists. When both the old and the new separation name are a comma separated list and both lists have the same number of comma separated parts, then the old name and new name lists are split where each part of the source is mapped on the corresponding part of the new name. For example: When old name 'A, B' and new name is 'X, Y', then A will become X and B will become Y.
      - When the separation book is also a comma separated list, these will be split in the same way. Otherwise (not a list), the separation book will be used for each mapping.

• **Reorder Separations**

You can specify the new order of separations, either in one row as a comma separated list of names or spread over different rows (see an example below). Wildcards and SmartNames are allowed.

Examples:

- C, \*, die cut
  - The first ink will be Cyan, the last one 'die cut'. In between, any other ink's order will not be changed.
- C, M, Y, K, \*, pantone \*
  - Process inks first, all PANTONE inks last.

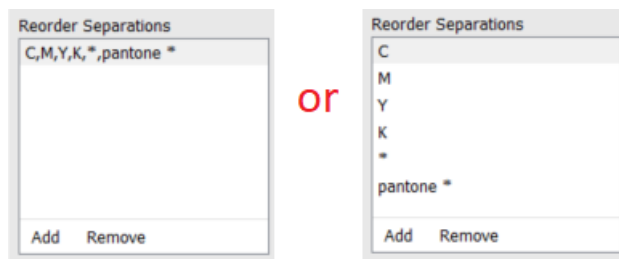

• **Convert Separations to CMYK**

- Specify the (spot) colors that you want to convert to process colors (CMYK).
- Process colors that are needed for the conversion but that are not yet in the file will be added to the output file (at the end of its list of separations).

- **Except for:** Specify the separations that were defined to be converted but that should not be converted.
- **Spot Color Lookup**

Choose which CMYK values should be used for the conversion of that spot color:

- **Look in Ink Books Only:** To use the CMYK values as defined in the Esko CMS (not available for custom inks).
- **Use Colors in File:** To use the CMYK values that are saved in the PDF file.

### 6.150.6. Tab 'Remove Separations'

You can select the separations by their **Name** or by their **Printing Method**.



**Note:** Selection by printing method does not support wildcards (\*).

- **Remove Separations**
- **Keep Separations.** All separations that you specified in the above 'remove' section will be removed unless you have specified it here.

### 6.150.7. Tab 'Separation Properties'

- **Apply Separation Type**



**Attention:** The types **Varnish** and **Technical** are only valid in *normalized PDF* files. When asking to set these types on other PDF files, the task will not make any type changes and end in warning.

- **Apply Printing Method**

Printing methods can be defined in the **Configure** panel (**Pilot > Configure**) or in ArtPro+ (**Edit > Options**). This list of methods is synchronized when the editor is set up to use the AE server.

### 6.150.8. Tab 'Document'

When selected, these actions will be applied in the order as they appear in this tab. For example: first increasing the line width and then outlining the strokes,

- **Merge similar path & text:** Select this to combine a path or text box that is composed of different identical objects (shape, size and position) on top of each other, into one object.
- **Contourize text:** Select this to replace editable text by a group of paths and compound (merged) paths.



**Note:** This function does not work on Dynamic Marks or protected objects.

- **Increase line width:** Select this to increase the stroke width of all objects that have a stroke width smaller than the specified minimum value.
  - **Minimum Line Width:** Define the minimal width that all strokes should have.
- **Outline Strokes:** Select this to replace stroked objects by a group consisting of a path (the fill object) and compound path (the outlined) stroke.
- **Clean up groups & clipping masks:** Select this to remove redundant groups and clipping masks (for example a group as sole component in another group).
- **Execute clipping masks:** Select this to crop objects on their clipping mask, and then to also remove the clipping mask and anything that was clipped away. During the process, affected strokes and live text are contourized.

### 6.150.9. Tab 'Page Boxes'

The 5 PDF Page Boxes:

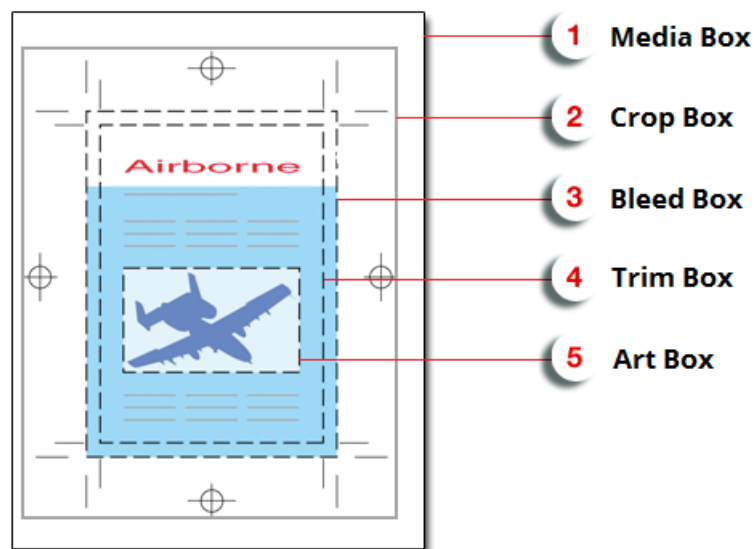

1. **Media Box:** This is the page format.
2. **Crop Box:** This includes the Bleed box and all marks.
3. **Bleed Box:** This is the trimmed page plus the bleed.
4. **Trim Box:** This is the net document format.
5. **Art Box:** The Art box can be used to specify any section of the page.

- **Adjust Page Box**

Select the type of **Page Box** and how you want to adjust its **Size** or **Position**.

- **Based on:**
  - Select **Absolute (Background)** if you want to define the selected page box independently of the file's contents or existing page boxes.

- Select **Content** if you want to base the selected page box on the file's contents. This takes clipping paths and masks into account.



**Note:** Default directions (positive values) are horizontally to the right and vertically upwards.



**Note:** Use a negative value to reduce the page box size or a reverse offset.



**Note:** The task first executes the alignment and only then the offsets.



**Note:** You can adjust multiple page boxes.

Learn more in the [ArtPro+ user guide](#).

- **Outline Page Box**

This makes page boxes visible by giving them a colored stroke. This allows to inspect page boxes in applications that have no means to visualize them.

## 6.151. Outline Fonts (Classic)

---

This task will contourize all fonts in the file and in all the files it refers to. Both live and composed text will be contourized. 'Internal' text (executed SmartMarks for example) is already contourized.

The task outputs a different PDF and by default adds the suffix `_c` to its name (use SmartNames to overruled this behavior).



**Tip:** When the input file did not contain any fonts, the [Details pane of the Task](#) and its log file mention this.

## 6.152. Preflight Color for Digital Printing (Ink based)

---

This task is documented in the chapter [Digital Printing Workflow](#) on page 1589. Find a direct link [here](#).

## 6.153. Preflight Color for Digital Printing (Content based)

---

This task is documented in the chapter [Digital Printing Workflow](#) on page 1589. Find a direct link [here](#).

## 6.154. Preflight Color for Equinox

---

You can use this task to decide which ink set to use when sending a print job to your expanded gamut printing press.

Some print jobs can be printed just as well with less inks (reducing not only the ink cost but also the print time needed), but it's often cumbersome and time consuming to check this manually for every print job.

This task automates the checking and comparison process: it calculates the color accuracy you can achieve with the ink set(s) you are thinking of using, to help you choose a cost-effective solution that will still meet your quality standards.

### Checking the Color Accuracy Achievable with a Certain Ink Set

If you want to check whether a certain file can be printed with a certain ink set and give a color accurate result:

1. Choose a color strategy made for printing with that ink set.
2. Set your color deviation tolerance (above which Delta E value you would consider the print not color accurate enough).
3. Send your file through the task.
4. The task outputs a detailed report: for each ink in your file needing conversion to your ink set, you can see the percentages of the inks on press that would be used, and whether the color accuracy would meet your tolerance.

Any ink that cannot be printed within your tolerance is given a "fail" status.

Your file only has an overall "pass" status if all its inks have a "pass" status. This means that you can print it color accurately with that ink set.

See [Task Parameters](#) on page 419 for more information about setting up your task.

### Comparing the Color Accuracy Achievable with Different Ink Sets

You would typically run your file through several **Preflight Color for Equinox** tasks in a workflow: one task for each color strategy/ink set that you want to check.

Each task then outputs a report detailing the color accuracy you can achieve with that color strategy/ink set, and gives an overall "pass" or "fail" status for printing your file with that ink set.

This helps you can choose the smallest ink set that gives you a good color match for that file, so that you can combine quality and cost-efficiency.



**Note:** The detailed information in the reports helps you take an informed decision in difficult cases. The final decision always rests with you.

You can use this task:

- on the production floor, to help you maximize the speed and cost-efficiency of your expanded gamut printing press while still printing your jobs with good color accuracy.

See [Preflight Color for Production](#) on page 424.

- if you have a sales office, you can use it to help you quote a competitive price to your customers without skimping on quality (you can then pass on the ink set information to your prepress/printing department, saving them the time it would have taken them to check different ink sets).

If your sales office uses an MIS system, you can even integrate a **Preflight Color for Equinox** workflow with your MIS system.



See [Preflight Color for Cost Estimation](#) on page 427.

### 6.154.1. Task Parameters

Set up each task's parameters as follows:

1. Decide which ink set you want to check your file against, and select a **Color Strategy** whose output profile uses this ink set.

Depending on whether you want to decide on an ink set for production or for cost estimation, the exact color strategy you choose may be different.

See [Preflight Color for Production](#) on page 424 and [Preflight Color for Cost Estimation](#) on page 427.



**Attention:**

- You can only select an **Equinox color strategy**. If you select another type of color strategy (through a SmartName for example), the task will end in error.  
You can create Equinox color strategies in Color Pilot, see [the Color Pilot documentation](#) for details.
- The task will also end in error if it cannot find your chosen color strategy in the color database (if for example it was deleted before you ran the workflow).

2. Select the **Delta E Formula** to use to calculate the color difference between the spot colors in your file and how they can be reproduced using your chosen **Color Strategy**.

You can choose from:

- CIELAB Delta E,**
- Delta E 94,**
- Delta E 2000,**
- CMC (1:1),**
- CMC (2:1),**
- Delta E 2000 (2:1:1).**



**Note:** If your company is already using one of those formulas, we recommend that you choose the same one. If not, you should choose **Delta E 2000**, which is the best reflection of the visual difference between colors.

3. Choose how close (in Delta E) the output colors must be to the colors in your input file for you to accept the print job as color accurate, and enter this number in **Delta E Tolerance for Spot Colors**.

The default tolerance is 2 Delta E, as color deviations under this threshold are generally not visible to the human eye.

### 6.154.2. Preflighting a File's Colors

You can send either PDF or Normalized PDFs files through this task. When working with regular PDFs, it will automatically normalize them using the **Normalize ticket** that is selected in the **Configure** tool's [Processing Preferences](#).

When running a file through this task:

1. The task calculates how to convert the file's separations to your chosen *Color Strategy's* output profile.

It checks all separations except:

separations that should be output as they are	<ul style="list-style-type: none"> <li>• process separations</li> <li>• other separations used in the output profile (when checking against a multicolor profile)</li> <li>• separations set to "Keep in Output" in the color strategy (for example White or metallics)</li> </ul>
separations that never require color management	<ul style="list-style-type: none"> <li>• technical separations</li> <li>• varnish separations</li> </ul>



**Note:**

- Separations that have conversion values defined in your color strategy's exceptions list are checked.
- The **Preflight Color for Equinox** task will only check opaque inks if you are using an Equinox color strategy that is set to convert opaque inks.
- The task will only check unregistered inks if your Equinox color strategy is set to convert unregistered inks.

For more information about Equinox color strategy options, please see [the Color Pilot documentation](#).

2. For each separation, it checks whether the color difference between the converted color and the original color is within the *Delta E Tolerance* you have specified, and gives a **pass** or **fail** status.
3. It writes all of the **pass** or **fail** statuses for that file into an XML report, and gives an overall **pass** or **fail** status for that color strategy (**pass** means that the color difference is within your Delta E tolerance for all separations, but if at least one separation has a higher Delta E then the overall status is **fail**).

You can see the preflight results in the **Log Info** or the **XML report**. See [Color Preflight Results](#) on page 421 for more information.

4. When running your file through several **Preflight Color for Equinox** tasks in a workflow, you can see which color strategies give a **pass**, and choose to use the smallest ink set that still gives you a good color reproduction.



**Note:**

- To see more details on the color reproduction of each color strategy, you can either check their XML reports manually or feed them to your MIS system.
- The final decision on what color strategy to use always rests with you.

If for example one of the color strategies gives you good Delta Es for all separations but one, and that separation is only present in a very small and less important area of your file, you can still decide to use that color strategy anyway.

If none of the ink sets/color strategies gives a good color reproduction, you may want to (depending on the case) use one or more additional spot colors, print the file with one of the color strategies anyway, tweak the color strategy in Color Pilot, adjust the file...

For more information about using several **Preflight Color for Equinox** tasks in a workflow, see:

- [Preflight Color for Cost Estimation](#) on page 427
- [Preflight Color for Production](#) on page 424

### Color Preflight Results

#### Processing Status

- After running the **Preflight Color for Equinox** task on your input file, the **Tasks** pane shows the processing status (and not the preflight status).



Task status	Processing status
✔ <b>Successfully done</b>	Input file processed successfully (whether the Delta E values for the ink conversions are within your required tolerance or not)
⚠ <b>Done with warning</b>	Input file contains unregistered inks (inks that are not part of an ink book in your color database)
✘ <b>Failed</b>	The color strategy is invalid or doesn't exist

To see the preflight status (and detailed results), you should open the task's [Log Info](#), or the [XML report](#) it produced.

- When running the task in a **workflow**, the XML report is sent through a different output pin depending on both the processing status and the preflight status.

There are 5 output pins, corresponding to the following statuses:

Output pin	Processing status	Preflight status
● <b>Pass</b>	Input file processed successfully	With this color strategy, all conversions are within your Delta E tolerance
● <b>Fail</b>	Input file processed successfully	With this color strategy, at least one of the conversions gives a Delta E above your tolerance

Output pin	Processing status	Preflight status
 <b>Pass Unregistered</b>	Input file contains unregistered inks	All conversions are within your Delta E tolerance
 <b>Fail Unregistered</b>	Input file contains unregistered inks	At least one of the conversions gives a Delta E above your tolerance
 <b>Error</b>	The color strategy is invalid or doesn't exist	Cannot preflight





**Note:**

Equinox color strategies have an option to convert unregistered inks or not (see the [Color Pilot documentation](#) for more details).

- If your color strategy doesn't convert unregistered inks, the preflight either passes or fails depending on the conversion values of the registered inks only.
- If your color strategy converts unregistered inks, the preflight either passes or fails depending on the conversion values of both registered and unregistered inks.

For example: you have an input file containing registered inks that can be accurately reproduced with CMYK, and an unregistered ink that cannot. You are preflighting it against a CMYK ink set.

When using a color strategy that doesn't convert unregistered inks, the preflight will succeed (the report will go through  **Pass Unregistered**).

However, when using a color strategy that converts unregistered inks, the preflight will fail (the report will go through  **Fail Unregistered**).

**Preflight Results Details in the Log**

You can see the preflight results in detail in the task's [Log Info](#).

Retrieving ink list from input file...

Ink 1: process C)  
 Ink 2: process M)  
 Ink 3: process Y)  
 Ink 4: process K)  
 Ink 5: visualizer gloss spot UV varnish)  
 Ink 6: pms1000m Violet)  
 Ink 7: pmetc 10249)

Using color strategy 'ColorPreflight\_CMYKOV'  
 Using delta E formula 'CIELAB Delta E'  
 Using tolerance 2.0

Output inks:  
 Process cyan  
 Process magenta  
 Process yellow  
 Process black  
 ClassicColors Violet

Results:

Ink 1 is a process ink.(process C)  
 Ink 2 is a process ink.(process M)  
 Ink 3 is a process ink.(process Y)  
 Ink 4 is a process ink.(process K)  
 Ink 5 is a varnish ink. (visualizer gloss spot UV varnish)  
 Ink 6 is converted using the default conversion settings. Values = 0.0 6.7 0.0 16.9 0.0 0.0 89.8 (visualizer gloss spot UV varnish) Delta E = 0.2  
 Ink 7 is converted using the default conversion settings. Values = 82.4 0.0 0.0 32.9 0.0 0.0 80.0 (pms1000m Violet) Delta E = 0.2  
 PASS

Under **Results**, it lists:

- which of the input file inks were converted by your chosen color strategy (*certain ink types* are never converted)



**Note:** If your input file contains a double strike of an ink (a percentage above 100%), this ink will appear twice.

- the conversion values for those inks (in percentages of the printing inks)
- the Delta E achieved for each converted ink
- the overall **PASS** or **FAIL** status



**Attention:** After running a workflow containing the **Preflight Color for Equinox** task, make sure you open the task's **Log Info** and not the workflow's **Log Info** (as the workflow's log only contains processing information).

### Preflight Results Details in the XML Report

Each **Preflight Color for Equinox** task also generates an XML report containing detailed results about the conversion to your chosen color strategy with your desired Delta E tolerance.

```
<?xml version="1.0" encoding="utf-8"?>
<CheckStrategy Strategy="ColorPreflight_CMYKOV" NumberOfInksUsed="5" OutputInksUsed="cyan;magenta;yellow;black;Violet"
Status="passed">
  <PassFailSettings DeltaEMetric="CIELAB Delta E" Tolerance="2"/>
  <SpotColorSet>
    <SpotColor InkName="C" InkBookName="process" status="IsProcessInk"/>
    <SpotColor InkName="M" InkBookName="process" status="IsProcessInk"/>
    <SpotColor InkName="Y" InkBookName="process" status="IsProcessInk"/>
    <SpotColor InkName="K" InkBookName="process" status="IsProcessInk"/>
    <SpotColor InkName="gloss spot UV varnish" InkBookName="Visualizer Standard Finishes" status="IsVarnish"/>
    <SpotColor InkName="Violet" InkBookName="PANTONE Colors Matte" DeviceColor="0.000 0.067 0.000 0.169 0.000
0.000 0.898" DeltaE="0.15" status="UsesDefaultConversionSettings"/>
    <SpotColor InkName="10249" InkBookName="PANTONE+ Premium Metallics Coated" DeviceColor="0.824 0.000 0.000
0.329 0.000 0.000 0.800" DeltaE="0.17" status="UsesDefaultConversionSettings"/>
  </SpotColorSet>
</CheckStrategy>
```

It contains the same information as the log, but is formatted to be easily usable by an MIS system (or Automation Engine's [Join XML Files](#) task, in preparation for sending to an MIS system).

If you are reading this XML report yourself:

- you can find the overall status at the top of the file (for example `Status="passed"`),
- you can check which of the input inks were converted ([ink types that are never converted](#) indicate the reason in their status, for example `Status="IsProcessInk"` or `Status="IsVarnish"`),
- for the inks that were converted, you can see the resulting percentages of the printing inks in `DeviceColor`, and the `Delta E` achieved.

### 6.154.3. Preflight Color for Production

You can use the **Preflight Color for Equinox** task on the production floor, to help you maximize the speed and cost-efficiency of your expanded gamut printing press while still printing your jobs with good color accuracy.

When using this task to prepare for production, you want to decide on the ink set to use for your print job, but you may also want to take into account any tweaks necessary to get the best color result on your particular press.

This means that for each **Preflight Color for Equinox** task that you run on your file, you should select a [Color Strategy](#) using your press profile as an output profile.



**Tip:**

When profiling your expanded gamut printing press in Color Pilot, you can easily generate:

- a color strategy with your press profile as output profile,
- additional color strategies with a subset of that profile's ink set as output profile (for example, if you profiled your press with a CMYK0V ink set, you can also generate color strategies to output to CMYK, CMYK0 and CMYKV on that press).

See [the Color Pilot documentation](#) for details.

#### Example Workflow

One of the simplest ways to set up a workflow to check what ink set a file can be printed with is to cascade several **Preflight Color for Equinox** tasks.



1. This workflow first marks the input file with a tag 'File to Preflight' and then sends it to the first **Preflight Color for Equinox** task.
2. This task checks whether printing the file with a CMYK color strategy would give a good color accuracy.



**Note:**

Make sure the color strategies you use in all your **Preflight Color for Equinox** tasks:

- are Equinox color strategies,
- use (one of) your expanded gamut printing press(es)'s profile as output profile.

For information about generating color strategies outputting to several ink sets from an expanded gamut printing press profile, see [the Color Pilot documentation](#).

The task outputs an XML report detailing the color accuracy that can be achieved.

- If printing the file with CMYK would give good results, the report goes through the **Pass** output pin (the first green pin), and the workflow is finished.
- If CMYK doesn't give a good color accuracy, the report goes through the **Fail** output pin (the second green pin), and the workflow continues.
- If your file contains one or more unregistered inks (inks that do not exist in your color database), it goes through one of the orange output pins (either **Pass Unregistered** or **Fail Unregistered** depending on the Delta E values).

In this case, the workflow ends with a warning (regardless of the Delta E values, the file isn't checked by any other **Preflight Color for Equinox** task).



**Note:** You can also choose to include unregistered inks in the conversion check, and not end the workflow with a warning straightaway. See [Workflow Variant Supporting Unregistered Inks](#) on page 426).

- If the color strategy you have selected in your first **Preflight Color for Equinox** task doesn't exist (if for example it was deleted before you ran the workflow) or is not an Equinox color strategy, the report goes through the red **Error** output pin and the workflow ends with an error.

3. If the first color strategy (CMYK) didn't give a good color accuracy, the XML report going through the second output pin triggers the **Select Marked File** workflow control.

This is set to select the input PDF/Normalized PDF corresponding to that XML report (using the `File to Preflight` tag and **Only select when name matches: [File]**).

See [Mark File and Select Marked File](#) on page 828 for more information.

4. That input PDF/Normalized PDF is then passed on to the next **Preflight Color for Equinox** task, that checks whether printing the file with a CMYKO color strategy would give a good color accuracy.
5. If this is not the case, the file is checked against a CMYKOV color strategy, then if necessary a CMYKOGV one.
6. If none of the ink sets/color strategies gives a good color reproduction, the workflow ends in a warning.

You can then check the different XML reports to help you make a decision about how to print your file.

Depending on the case, you may want to use one or more additional spot colors, print the file with one of the color strategies anyway, tweak the color strategy in Color Pilot, adjust the file...

### Workflow Variant Supporting Unregistered Inks

Depending on the way you work, you can choose to either have the workflow end in warning if your input file contains unregistered inks (as described above), or calculate these inks' conversion values as part of your color preflight.

To do this, you need to:

1. use Equinox color strategies set to convert unregistered inks (see [the Color Pilot documentation](#) for more details),
2. amend your workflow so that **Pass Unregistered** and **Fail Unregistered** go to the same places as **Pass** and **Fail**.

For example, for the first preflight task (**Preflight for CMYK**):

- instead of:

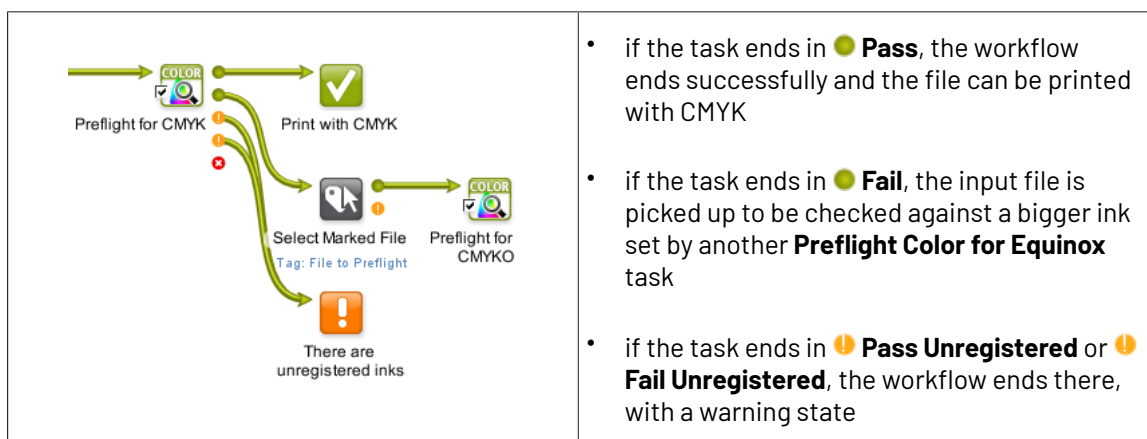

- you would have:

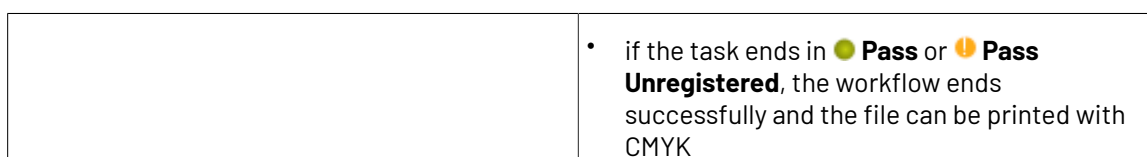



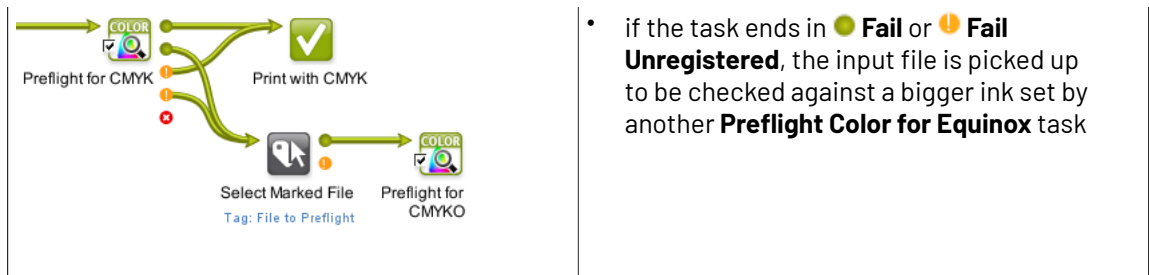

- if the task ends in **Fail** or **Fail Unregistered**, the input file is picked up to be checked against a bigger ink set by another **Preflight Color for Equinox** task

Your workflow would then look like this:



**Note:**

- If your color strategy doesn't convert unregistered inks, the preflight either passes or fails depending on the conversion values of the registered inks only.
- If your color strategy converts unregistered inks, the preflight either passes or fails depending on the conversion values of both registered and unregistered inks.

For example: you have an input file containing registered inks that can be accurately reproduced with CMYK, and an unregistered ink that cannot. You are preflighting it against a CMYK ink set.

When using a color strategy that doesn't convert unregistered inks, the preflight will succeed (the report will go through **Pass Unregistered**).

However, when using a color strategy that converts unregistered inks, the preflight will fail (the report will go through **Fail Unregistered**).

### 6.154.4. Preflight Color for Cost Estimation

You can use the **Preflight Color for Equinox** task at your sales office, to help you quote a competitive price to your customers without skimping on quality.

You can even connect it to your MIS system (for example CERM or Label Traxx), to get the print job information automatically, then send the color preflight results back to the MIS.

When using this task for cost estimation, the main goal is to decide on the ink set needed to print your job with a good color accuracy.

At that stage you don't need to worry about tweaking the print job to print on a specific press so you can use a [Color Strategy](#) with a generic output profile (for example ISOcoated\_V2\_eci.icc for the CMYK ink set).

### Example Workflow

There are many ways you can set up a workflow that checks what ink set a file can be printed with so you can quote a competitive price to your customers. For example, you can:

- Set up a cascading workflow that checks the file against each ink set, then check the workflow's results to choose the ink set to use (this is similar to the [production workflow](#), but here you can use generic color strategies with the right ink sets, instead of color strategies made for a specific expanded gamut printing press).
- Set up a workflow with one **Preflight Color for Equinox** task, where the color strategy and Delta E tolerance are public parameters, and enter all the color strategies you want to check as a semicolon-separated list (for example CMYK; CMYKO; CMYKOV; CMYKOGV). For each color strategy you specify, your file will go through the task and you will get an XML report.
- Set up a workflow that integrates with your MIS system, so that you can automatically launch the workflow on any file that comes into your MIS system for quotation, and get the results back into your MIS system (this way you can do this from your sales office without even needing to open the Automation Engine Pilot).

### Workflow with MIS Integration

This example workflow is set up to:

- take a PDF file,
- check it against a list of color strategies and a specific color tolerance (that are saved as [workflow parameters](#)),
- join all XML reports into one and save it in a location that your MIS system monitors,
- end in **OK** for the color strategies that can be used to print within the color tolerance, and in **Warning** for [all other cases](#).

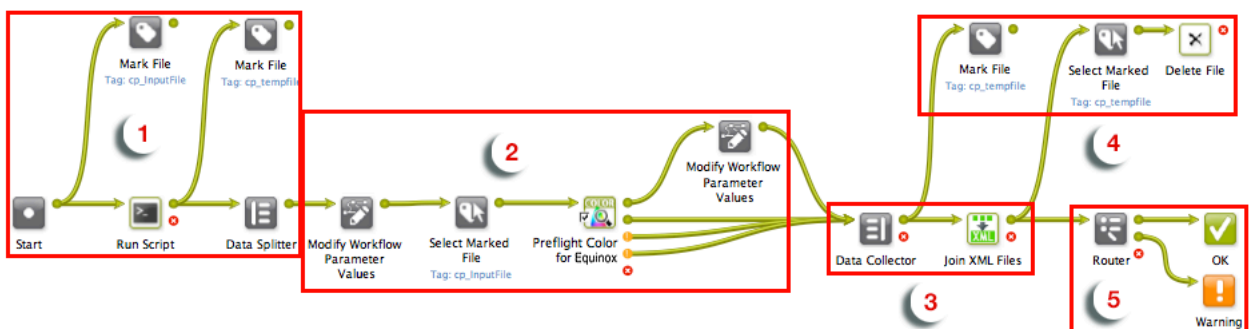

### 1. Preparation

The input file is paired with every color strategy that needs checking, and sent through the workflow as many times as there are color strategies.

- a. The input file is marked with the cp\_InputFile tag so it can be picked up by the workflow later on.

- b. The **Run Script** task generates an XML file for each color strategy, containing the input file name and color strategy name. Those XML files are marked as `cp_tempfile`.
- c. The **Data Splitter** sends the XML files one by one to the rest of the workflow, where they will each trigger a color strategy check.

## 2. Color Preflight

For each input file/color strategy pair, the **Preflight Color for Equinox** task checks the color accuracy that can be achieved, and generates a detailed report.

For each XML file sent from the **Data Splitter**:

- a. The **Modify Workflow Parameter Values** workflow control picks up the color strategy name in the XML and saves it to the `SelectedStrategy` workflow parameter.
- b. The **Select Marked File** workflow control picks up the input file and sends it to the **Preflight Color for Equinox** task.
- c. The **Preflight Color for Equinox** task checks whether converting the input file with the current color strategy (from the `SelectedStrategy` workflow parameter) would give a Delta E within the required Delta E tolerance (from the `Tolerance` workflow parameter).

It outputs an XML report detailing the color accuracy that can be achieved with that color strategy, through the [appropriate output pin](#).

- d. If the file can be printed within the color tolerance using that color strategy, the `State` workflow parameter is set to `Pass`. Otherwise it is not changed.

## 3. Reporting

The **Data Collector** collects all XML reports and sends them to the **Join XML Files** task, to make a single big XML file for easy consumption by the MIS system. This file is saved in a location that the MIS monitors.

## 4. Cleanup

The individual XML reports are marked as `cp_tempfile` and, together with the other temporary files (the XML files produced by the **Run Script** task), they are deleted.

## 5. Workflow End State

The **Router** directs each iteration of the input file to the right workflow end state based on the `State` workflow parameter set by the **Preflight Color for Equinox** task.

- For color strategies that gave a Delta E within tolerance (the `State` is `Pass`), the file goes to **OK**.
- For color strategies that didn't (the `State` still has an empty value), it goes to **Warning**.

The MIS system can then check the end state of the workflow and analyze the joined XML file containing the color accuracy information for the input file checked with all color strategies.



### Note:

Like all Automation Engine workflows, this workflow can be triggered by a JDF file dropped into a "hot folder"/[folder access point](#) for example).

If the JDF contains information about the color strategies to check and the desired Delta E tolerance, they will overrule those set in the workflow parameters.

At the end of the workflow, the MIS system will get a JDF back, containing processing information and the location of the joined XML file.

## 6.155. Preflight with PitStop

---

This task is documented in the chapter [Quality Control tools](#). See [Preflight with PitStop Task](#) on page 1149.

## 6.156. Prefix Products on Esko Cloud

---

This task serves to avoid clashes in names of Products that are created on an Automation Engine server that is integrated with more than one MIS.

Because this task will typically be used in relation to an AE SaaS setup, it is described in the [chapter on AE SaaS](#). Find a direct link [here](#).

## 6.157. Prepare for Inspection

---

This task takes a JDF Layout file and creates a JDF Inspection file that will be read by a (press) inspection system. You can set specific measurement points in the design that the inspection system will then monitor.

The task generates

- a JDF Layout file, now with extra information for the inspection system
- a TIFF preview of the to-be-printed material
- a TIFF preview of the shape of the resulting label after die cutting (the 'Cut Mask')
- a MIME file containing all output files.

The JDF Inspection file contains

- the layout of the sheet(s) and for each one-up PDF the information about:
  - the contour of the retained area (**ClipPath**)
  - the location of the barcodes (**IdentificationField**)
  - the location of the text areas (**IdentificationField**)
  - the location and values of Spectrometer measurements (**CIELabMeasurement**)
- Information about VDP objects: their bounding box, type and subtype.

Learn more in [Settings](#) on page 432.

### Example Workflow

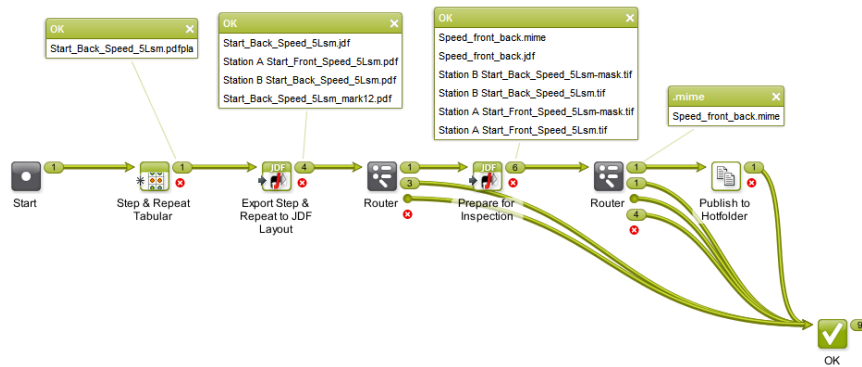

- This example workflow starts by creating a PDFPLA step & repeat file.
- It then exports this file as a JDF Layout file. This creates a JDF file and a self-contained PDF file for each one-up.
- The **Prepare for Inspection** task then uses this JDF layout to create the MIME file containing the JDF file and the TIFF previews.
- The next task publishes this MIME file to a hot folder to be picked up by the inspection system.



**Note:** Use the workflow control '**Router**' to make sure that the correct files are used as input file for the next step.

### Example of Preview and Cut Mask

Example label (one-up):



Example preview: Note that the cut path is not visible in this preview:.



Example Cut Mask:



### 6.157.1. Settings

#### Document Tab

Document

Separations

Create MIME pack  
 Render preview  
 Render cut mask

Preview Resolution:

JDF Job ID:

**Inspection Parameters:**

Name	Value

Add
Remove

- Select what the task needs to create:
  - **Create MIME pack:** A self-contained set with all output files. When not selected, the requested output files are created separately.
  - **Render Preview:** Creates a RGB TIFF preview file. When not selected, a PDF preview is created.
  - **Render cut mask:** Creates a TIFF preview file of the cut mask. When not selected, a PDF preview is created.
- **Preview Resolution:** Define the resolution of the preview TIFF file(s).
- **Preview Anti-aliasing:** If wanted, select the level of anti-aliasing to be applied in the preview TIFF file(s).

- **JDF Job ID:** Use SmartNames to make this result in the job identification that the inspection system should use to link the printed matter to this file.
- **Inspection Parameters:** Add extra parameters at will. For example the name of a profile that will define the settings for the inspection system (for example "adhesive label").

### Separations Tab

You can here define separations to be excluded, typically all the non-printable, technical inks like "Die Cut".

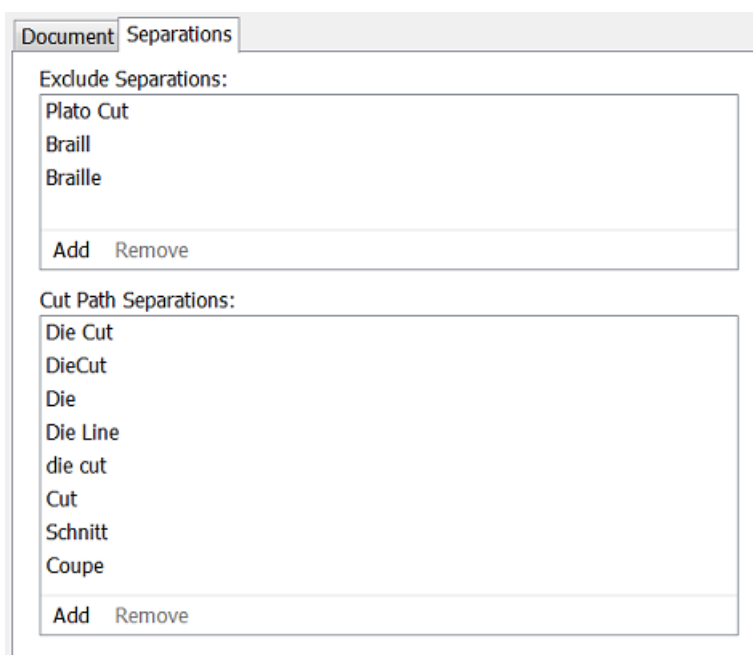

**Note:** Using the Adobe Illustrator Plug-in "Esko Data Exchange" or the application Esko PackEdge, you can include extra annotations inside the PDF file. These can serve to identify areas with different inspection requirements, or could be locations for colour measurements, including their expected LAB values and accepted tolerance. If such information is found inside the PDF file, it is added to the output JDF file.

## 6.158. Prepare for Sharing

### Concept

This task serves to prepare your production PDF+ file to be shared with 'others'. It typically serves to make the shared PDF smaller, uneditable, simpler.

This is the same functionality as in ArtPro+, in **File > Export to > PDF > Export to PDF**.

This task uses the [NDL / PAL technology](#).



**Attention:** This task does not change the content of any placed art: Its layers are not removed, images are not re-sampled and text is not outlined. When you also want these changes applied to the content of placed art, then first use an action list including the action "Expand Object" and optionally also the action "Unlink Placed Art"

### Task Settings

All these options are documented the [user manual of ArtPro+](#) (some of them in more detail).

- **Export Flavor:** You can select a preset which will force specific values or disable some options.
  - **For Press:** The option 'Add single-color page per separation' if forced off.
  - **For Press (PDF 1.3):** Same setting as 'For Press' but 'Image compression' is forced to 'Lossless', 'Outline text' is forced on and the output file will be PDF 1.3 (transparencies are resolved, layers are removed).
  - **For Viewing:** The option 'Outline text' is forced on and the task will resolve opaque inks and overprint. This output file will give the same preview in Adobe Acrobat as it does in ArtPro+, but is not suited for printing.
  - **Custom:** Same settings as with 'For Press', but with user control of the option 'Add single-color page per separation'.
- **Run Action List:** Aside from below options, you can use an action list to make any other changes to the output PDF. These changes will be executed before the other options in this ticket will be handled.
- **Layers:** Decide which content (by layers) is relevant for the party you are sharing the PDF to.
  - **Include processing steps:**
  - **Include non printing layers:**
- **Images:** Two options to reduce the size of the output PDF.
  - **Downsample to:** When selected, all images (excluding bitmap images) are downsampled to a specified resolution.
  - **Crop images to clip mask:** When selected, only the parts of the image within the clip mask are included in the PDF file.
- **Image compression:** Compressions with the biggest result often also lead to the most loss of data.
- **Apply on Export:**
  - **Outline text:** Makes text uneditable but also creates (much) more vector data in the PDF.
  - **Apply distortion:** Does the receiver want to see the end result with the press-distortion already applied?
  - **Include color profiles:** When color profiles are not embedded in the exported PDF, this can result in a different representation of the colors.
  - **Add single-color page per separation:** Select this to add extra pages showing the separations (one page for every separation).



## 6.159. Prepare for Viewer

---

This task is documented in the chapter [Quality Control tools](#). See [Prepare for Viewer Task](#) on page 1130.

## 6.160. Prepare for WebCenter Viewer (OBGE)

---

This task type is by default hidden.

It is only used by a WebCenter OBGE when a WebCenter user uploads a document in WebCenter.

It had different default behavior than the regular [Prepare for Viewer](#) task.

Only Esko staff can explicitly enable this task so that its task ticket becomes visible in Automation Engine / OBGE.

## 6.161. Prepare Graphics for Nesting (Classic)

---

The **Prepare Graphics for Nesting** task is documented in the chapter [Sign & Display Workflow](#) on page 953. Find a direct link [here](#).

## 6.162. Prepare Station (Classic)

---

This task prepares one ups for use in a Step & Repeat editor or task.



**Note:** Some of its features are also available in the more recent task [Prepare Graphics for Nesting \(Classic\)](#).

Create Station File

Extract Die using Ink Artios Cut

Load CAD

CAD File:  📁

Flip CAD

Mapping: TRN

CAD Style: <None>

Limit Bleed: 5 mm

Graphics for Backside:  📁

SmartMarks: Add to current set

📁

- **Create Station File:**

Select this if you want the task to create a PDFSTA file instead of a Normalized PDF. See down below how the sub-options are different when this is not selected.



**Attention:** PDFSTA files can only contain external references to Normalized PDF files. So only select this option when the input file is also a Normalized PDF (or the task will fail).

- **Extract Die using Ink:** When selected, the task creates a die line in the output file by extracting all contours of the specified Ink. This die line will automatically be used in Esko Plato or in tasks using Plato technology. When not selected, the trim box of the station file will be used as die shape.
- **Load CAD:** Select this to place a CAD file into the station file (an ARD or a 1-up CFF2 file).



**Note:** In case a layout CFF2 file is selected, the task will generate an error.



**Note:** When you only need to load a CAD file into the PDF, consider using the [Load Structural File task \(Classic\)](#) instead.

**Mapping:** When loading a CFF2 CAD file, choose how the CFF2 line attributes should be mapped to the ArtiosCAD line types. Select the appropriate **CAD Style** file to determine in which separations the different CAD lines will appear.

**Overview:**

When loading a CAD file, the following sequence of operations takes place:

- The graphics file is placed in a station.
- When **'Extract Die using Ink'** is selected, the die shape is extracted from the graphics. If not, die shape is set to trim box.
- The CAD file is loaded and the outline of the CAD file is compared to the outline of the die shape generated in the above mentioned step. The graphics is rotated in such a way to create a maximal intersection of the CAD outline and the outline of the die shape. Any rotation is mentioned in the task's log file.



**Note:** In the [Load Structural File task \(Classic\)](#) the CAD file is rotated and not the graphics.

- The CAD is taken as the die shape for the station.
- **Limit Bleed:** The bleed can be limited to a specific distance. The task create a bleed mask by spreading the die shape.
- **Graphics for Backside:** Select this to load a graphics file that will become the backside of the station file (also placed by external reference).



**Note:** Keep the following in mind about positioning graphics on the back side:

- If the PDF contains objects in the 'die ink', the graphics for the back side are positioned so that these objects are centered on the die of the front side.
- In the other case, the graphics on the back are positioned centered on the original borders of the front side graphics (i.e. not fitted).

- **SmartMarks:** Select this to load a SmartMarks set. Note that this one set will be used for both front and backside. Choose if you want to **Add them to the current set** or if they should **Replace** it.

**When not Creating a Station file**, the task creates a normalized PDF and the options are slightly different:

- The input file is opened and changed as requested (so it is not placed externally).
- The only options available are now:
  - **Fit Borders to Ink**: Borders can be fitted to objects in a specific ink
  - **Limit Bleed**
  - Placing **SmartMarks**.

## 6.163. Print

This task serves to print the input file on a PostScript printer that was configured on the Automation Engine server. Mind that in this case, this configuration is not part of an Esko tool, but we mean the standard way to add printing devices on that Windows computer.



**Attention:** These devices should be configured on the server using the **System Account** of Automation Engine. By default this is the local user **BGSYSTEM**, but you might have changed this (using the ['System Account' page in the Server Admin web page](#)). The **Print** task will not be available for devices configured by other users.

The task's settings are very similar to those explained in the page on the [Export to PostScript File \(Classic\)](#) task.

## 6.164. Print IMP File (Classic)

Learn more in the dedicated document on "Commercial Print (Imposition) workflows in Automation Engine". Find it next to the "Complete Manual" of version AE **18.1** on <https://www.esko.com/en/Support/Product?id=Automation%20Engine&ver=18.1>.

## 6.165. Print On Digital Press

---

This task is documented in the chapter [Digital Printing Workflow](#) on page 1589. Find a direct link [here](#).

## 6.166. Process PDF Spreads (Classic)

---

### Action

The ticket parameters depend on what type of **Action** you selected first.

- **Split Reader Spread:** To divide the reader spread pages in a multi-page PDF into 'single' pages (still in a multi-page PDF).
- **Make Reader Spread:** To change the 'single' pages in a multi-page PDF into reader spread pages.
- **Make Printer Spread:** To change the 'single' pages in a multi-page PDF into reader spread pages that can be used to create an imposition mock-up.

### Settings for 'Split Reader Spread'

- **Spread Position:**
  - **Reference Box:** Select a page box to choose how much of the page to include in, or retrieve from a spread. For example select **Crop Box** to crop everything outside that box.
  - **Offset:** Enter an exact offset distance from the above selected reference box. The offset distance will extend beyond the box boundaries. This parameter is commonly used when creating spreads of asymmetric files.
  - **Bleed Mode:** Control the placement and size of bleeds. Choose from:
    - **Remove Bleed:** Only the content of the reference box will be kept, any bleeds present in the input file will be removed.
    - **Bleed from Bleed Box:** The bleed will be the Bleed Box but only if the reference box is the Trim Box.
    - **Bleed from Bleed Distance:** This adds the specified bleed distance to the chosen reference box. A bleed distance will extend beyond the borders of the Trim Box and therefore will set the boundaries of the Media Box when output.
- **Spread Structure:**
  - **Flow Direction:** Determine whether pages are arranged in numerical order from either left to right or right to left. **'Left to Right'** means that page one will be on the left hand side of a two-page spread, with the second page on the right. **'Right to Left'** means page one will be on the right hand side of the spread, with page two on the left hand side.
  - **First Spread Contains:** This controls how pages will be organized in the output file:
    - **Page 1 and 2**

To divide a spread into single pages. If you use this mode in conjunction with the option **Mixed Spreads** (see below), you can split spread pages in a file while leaving single pages intact.



**Note:** Note: The reference page for this splitting action using 'Mixed Spreads' should be a spread page, not one of the single pages.

- **First page only**

If you place the first page of the file on the right-hand side of the first spread page; the left-hand side remains blank.

For files with an even number of pages, the last page will be also be placed on a spread page, on the left-hand side, with an accompanying blank page.

The left / right positioning of pages on spreads is determined by the selection made in the field **Flow Direction**. The description above assumes a left to right flow direction.

- **Last and First page**

In this mode, the last and first page of the input file are placed side by side on the first spread page.

In a left to right flow direction setting, the last page will be on the left and the first page on the right of the first spread page output.

In "Split Reader Spread" mode the task simply reverses the make mode. A file with spread pages will have the spread pages split but the page on the left side of the first spread will be output as the last single page of the output file.

- **Even number of pages**

Use this to prevent input files with an even number of pages from losing any pages while being split.

The parameter produces different results depending on which of these spread types it is combined with.

- Select **'Even Number of Pages'** together with the spread type **'First Page Only'** to split the output file. The left side of the first spread and the right side of the last spread will not be output.
- A combination of the **Last and First Page** spread type and the **Even number of Pages** parameter will split a file successfully.



**Note:** This option is active only when the Action 'Split Reader Spread' is selected and with spread types 'First Page Only' and 'Last and First Page'.

- **Mixed Spreads:**

Use this option when you need to define the Reference page for input files that have various paper sizes.

For example, if a file contains both an A4 page as page one and a two-page spread as page two, enter page two as the reference page and indicate that this page has two pages on it. All the spread pages are correctly detected and split correctly while leaving the single pages intact.

- **Auto Detect Spread Reference:** To take the most frequently featured page size as the Reference page.

- **Reference Page Number:** To specify an exact page as the Reference Page. Use the actual page number in the series of pages, not the page's number *label*.
- **Reference Page contains X One-Ups:** Enter the number of single pages to be positioned on the Reference Page.

### Settings for 'Make Reader Spread'

Select this Action to, in a multi-page PDF, create spread pages from single pages.

The options Spread Position and Spread Structure are the same as when you selected the Action 'Split Reader Spread'.

### Settings for 'Make Printer Spread'

Select this Action to create spread pages that can be used to make an imposition mock-up from single pages.

The options Spread Position and Spread Structure are largely the same as when you selected the Action 'Split Reader Spread'.

## 6.167. Proof for Contract Approval

---

This task is part of the Pack Proof product. Learn more in the [user guide of Pack Proof](#).

## 6.168. Proof for Content Approval

---

This task is explained in the chapter on [Imaging Engine](#). Find a direct link [here](#).

## 6.169. Proof to File - Unscreened

---

This task is documented in the chapter on [Imaging Engine](#). Find a direct link [here](#).

## 6.170. Publish Imposition on WebCenter Chain

---

Learn more in the dedicated document on "Commercial Print (Imposition) workflows in Automation Engine". Find it next to the "Complete Manual" of version AE **18.1** on <https://www.esko.com/en/Support/Product?id=Automation%20Engine&ver=18.1>.

## 6.171. Publish On WebCenter

---

This task is documented in the chapter *Integrating with WebCenter* on page 1741. Find a direct link [here](#).

## 6.172. Relocate Job

---

This task is documented in the *separate chapter on Jobs*. Find a direct link [here](#).

## 6.173. Remove Esko Cloud Link

---

This task is documented in the chapter *Integrating with Share & Approve* on page 1762. Find a direct link [here](#).

## 6.174. Remove Files from Shared Job

---

This task is documented in the chapter *Sharing to Collaborate with other AE servers* on page 1685. Find a direct link [here](#).

## 6.175. Remove Job

---

This task is documented in the *separate chapter on Jobs*. Find a direct link [here](#).

## 6.176. Remove Product

---

This task is documented in the *separate chapter on Products*. Find a direct link [here](#).

## 6.177. Resize PDF for Output (Classic)

---

This task allows to resize a PDF's pages or its contents before output to a proofer or RIP.

### Output Page Size:

- Select '**Resize to a specific page size**' to adjust the PDF markup for a given paper size.
- Deselect it if you only want to adjust the page contents (page boxes, etc.).

This option affects which parameters you see in **Page Size** and **Page Content**:

### 6.177.1. Resizing to a Specific Page Size

When **Resize to a specific page size** is selected, you have these options:

1. In the **Page Content** area, select the **Page Box to Use** for positioning, scaling, etc.
2. Select how to **Position** this page box and its contents on the page:
  - **Don't Fit**: The file is placed "as is".
  - **Center on Page**: The file is centered in the selected page box.
  - **Scale to Fit (Reduce Only)**: The task scales the file down if necessary, so it fits in the selected page box.
  - **Scale to Fit (Reduce & Enlarge)**: The task scales the file up or down if necessary, so it fits in the selected page box.
  - **Scale to Fit (Disproportional)**: The task disproportionally scales the file up or down if necessary, so that it fits in the selected page box.
  - **Use Proportional Tiling**: The task tiles the file over several pages as necessary, but make all tiles the same size.
  - **Gripper on Top**: The task leaves space for the gripper at the top of the page.
  - **Gripper at the Bottom**: The task leaves space for the gripper at the bottom of the page.

When selecting **Use Proportional Tiling**, you can enter the size of the **Tile Overlap** (where two tiles are partly on top of each other).

When selecting **Gripper on Top / Bottom**, enter the amount of space needed for the gripper in **Gripper Size**.

3. **Mirror page** mirrors the page contents and the page boxes horizontally.
4. If you want, use the **Scale** parameter to scale the artwork before placing it on the page.
5. If you want, enter a **Horizontal** and/or a **Vertical Distortion** to apply to the artwork before placing it on the page.

You can either enter the distorted output values (for example 97% or 103%), or the positive/negative distortion values (for example -3% or +3%).

6. Select **Clip on selected page box** to clip away all artwork outside the page box that you selected in **Page Box to Use**.



**Note:** The artwork outside the selected page box is not deleted, just clipped away by a clipping path (it is invisible but still present in the file).

7. Select **Crop to fit** if you want to crop your Page Box to the content of your original file.

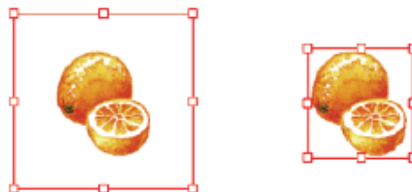

8. In the **Page Size** area, select the page size you intend to print to in **New Page Size**.



This page size is used by the **Scale** and **Position** parameters.

- If you select a predefined page size, the option **Orientation** allows to select the orientation of the paper that you intend to use. Choose either **Portrait** or **Landscape**.
- If you select **Custom** as a page size, you will see a **Page Width** and a **Page Height** fields where you can enter the dimensions of the custom paper you intend to use.

**9.** Enter the **Page Margins** required by the output device.

The **Page Margins** value is used for the four sides of the page. These margins cannot be used for exposing.

### 6.177.2. Not Resizing to a Specific Page Size

If you don't select **Resize to a specific page size**, you can resize or reposition the PDF contents:

- 1.** In the **Page Content** area, select the **Page Box to Use** for positioning, scaling, etc.
- 2.** Select **Center content on page** if you want to center the page contents on the page.
- 3.** Select **Mirror page** if you want to mirror the page contents horizontally.
- 4.** If you want, use the option **Scale** to define a scaling to apply to the artwork before placing it on the page.
- 5.** If you want, enter a **Horizontal** and/or a **Vertical Distortion** to apply to the artwork before placing it on the page.

You can either enter the distorted output values (for example 97% or 103%), or the positive/negative distortion values (for example -3% or +3%).

- 6.** In the **Page Size** area, use the option **Set Orientation** to alter the orientation of every page without resizing it. Choose between **Keep**, **Portrait** or **Landscape**.
- 7.** Use the options **Rescale page boxes** and **Rescale page size** to define what happens when you scale the page contents:
  - a) Select **Rescale page boxes** to scale the page boxes together with the contents.  
Deselect it to only scale the page contents and not the page boxes.
  - b) Select **Rescale page size** to scale the page size together with the contents.  
Deselect it to only scale the page contents and not the page size.

## 6.178. Resize Shape

---

### Concept

This task outputs a resized version of a Studio Toolkit .zae input file (an Archived Collada format).



**Note:**

- The input file may only have one bag object.
- The bag object cannot be a *Ponytail bag*.
- The task will fail when the input file was made with a newer version of the software than the one that this task uses.



**Note:** Learn more about Studio on [the Esko website](#).

Here's an example of a pillow bag as seen in Studio Toolkit:

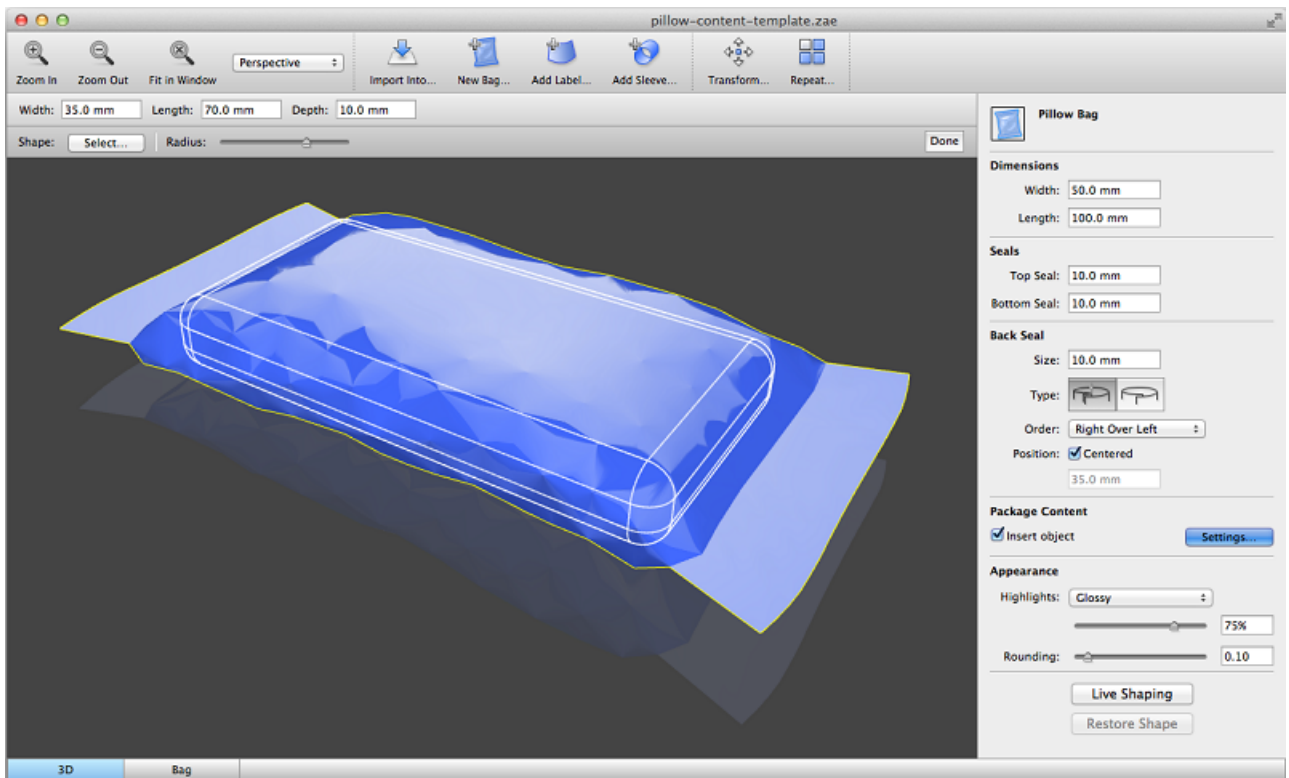

### Task Options

The ticket lets you specify new values for the **dimensions** of the bag, its **seals** and/or dimensions of its **package content**.

Not every option applies to every bag type. That is why you can first select the bag type of the input file in **Show parameters for:**.

If you specify a value for an option that is not used for the type of bag in the input file, it will be discarded.

The numeric input fields can be used for calculations, also when using SmartNames.

The output file is a Studio Toolkit Collada file with updated dimensions:

- In 3D, the model is resized, just as if you opened it in Toolkit, entered new dimensions and saved it. However, the 3D orientation and height (distance to floor) are preserved.



**Attention:** Any "Live Shaping" improvements in the input file are lost.

- In 2D, the technical drawing is also adjusted. The dimension lines are preserved and the arrows preserved their relative position to the updated anchor points.

## 6.179. Resolve OPI (Classic)

---

This task serves to replace the low-resolution images in a PDF with their high-resolution versions that the PDF links to via OPI comments.

### Repository tab

- **Add** the location(s) of the external folder(s) that contain(s) the OPI-files.
- If necessary, add the location(s) of the **excluded folders**. These folders will not be searched.



**Note:** Use this option if all images can be found on the same volume and you want to exclude all folders containing low-resolution files.

- Select '**Update OPI links only**' to only update the links to the high-resolution images and to not replace the links by embedding the high-resolution images.

### Mapping tab

You can here specify a list of how file extensions should be mapped:

- Click **Add** and enter the original extension in the **From** field. If left blank, the extension in the **To** field will be applied to all linked files.
- In the **To** field, enter the new extension to give the linked files, or a comma-separated list of extensions to use as replacement for the original extension.



**Note:** If you enter multiple extensions, the task searches for a file matching one of them. Use the backslash ( \ ) to preserve a character (for example to use a comma as part of an extension and not as a separator).

## 6.180. Restore Job

---

This task is documented in the [separate chapter on Jobs](#). Find a direct link [here](#).

## 6.181. Reverse Trap

---

### Concept

Reverse trapping generates white lines to avoid colors touching or overlapping in case of mis-registration.

This is useful to prepare a job for Dry Offset printing (e.g. metal beverage cans) where overprinting of inks is not allowed as the inks would contaminate each other on the blanket.

### Task Settings

- **Distance:** The size of the reverse trap.
- **Joins:** A Mitered corner closes in one point. A Miter limit of 4 is used. This means the corner will be cut off at a distance of 4 times the trapping distance. A Rounded corner joins the corners with a circular arc with the diameter equal to the trapping width.
- **Trap Position:** Enter a value (%). 100% will position the Reverse Trap object completely in the selected direction (in most cases into the lightest ink). 50% will place the trapping object 50% in both directions (i.e. centered on the edge).
- **Close gaps smaller than:** Some files contain very small unintentional gaps between neighboring objects. These gaps prevent trapping of these objects. Although it is better to clean up such files before trapping, this task can ignore these gaps automatically. If you wish to use this, enter the maximum size that these small gaps can have.



**Note:** If you set a big gap size, trapping may become slower and some small parts may be ignored.

Learn all about its settings in the [manual of ArtPro+](#) , in **Prepress functions > Trapping > Trapping mode: Reverse Trapping > .**

### About (Reverse) Trap layers

This task creates a new layer "**Reverse Trap Layer**". Its type will be "Automatic Trap Layer", and it will contain all trapping objects.



**Attention:** A file can not contain both an Automatic Trap Layer and a Reverse Trap Layer. Creating a Reverse Trap Layer will remove an earlier created Automatic Trap Layer.

Reverse Trapping takes into account all objects in **printing layers**.

Non-printing layers and Processing steps will not be taken into account.

## 6.182. Route Approval Cycle

---

This task is documented in the chapter [Integrating with Share & Approve](#) on page 1762.

Find a direct link [here](#).

## 6.183. Router

---

This Workflow Control is documented in the chapter [Workflows](#). Learn more in [Router](#) on page 811.

## 6.184. Run ArtiosCAD Standard

---

### Concept

This task creates an ArtiosCAD ARD design based on an existing ArtiosCAD standard.

The task requires parameters as board information, units, grain direction, print side and dimensions.

### More Info

This task is set up by an Esko Solution Architect. Learn about Esko Solution Services on <https://www.esko.com/support/solution-services>.

For more information, search for online articles on this topic in the [Esko Knowledge Base](#).

## 6.185. Run Script

---

This task is documented in the chapter [Using Scripts](#) on page 1917. See [The Run Script Task](#) on page 1922.

## 6.186. Select File

---

This Workflow Control is documented in the chapter [Workflows](#). Learn more in [Select File](#) on page 817.

## 6.187. Select Files on Shared Job

---

This task is documented in the chapter [Sharing to Collaborate with other AE servers](#) on page 1685. Find a direct link [here](#).

## 6.188. Select Mark File

---

This Workflow Control is documented in the chapter [Workflows](#). See [Mark File and Select Marked File](#) on page 828.

## 6.189. Select Job

---

The **Select Job** workflow control is documented in the chapter [Workflows](#) on page 733. Find a direct link [here](#).

## 6.190. Select Product

---

The **Select Product** workflow control is documented in the chapter [Workflows](#) on page 733. Find a direct link [here](#).

## 6.191. Select Referenced File

---

This Workflow Control is documented in the chapter "Workflows". See [Select Referenced File](#) on page 821.

## 6.192. Send File to Automation Engine Agent

---

This task is documented in the chapter on [Automation Engine SaaS](#).

Find a direct link [here](#).

## 6.193. Send E-mail

---

This task uses your e-mail server to send e-mails.

Your mail server or account must first be correctly configured in the [E-mail item in the Configure tool](#).

The e-mail can contain:

- Custom text, typed in this ticket
- Any information that Automation Engine has, by using SmartNames,
- The task's input files.

1. Enter the e-mail address(es) you want the e-mail to be sent **To**.

When you work in a Job context that has customer information filled in, check if you can here use any of the customer e-mail addresses as a SmartName (category **Job Information**).

You can also use SmartNames to add the e-mail address of the Task Owner (category **Task information**). Learn more about SmartNames in the chapter [SmartNames](#).



**Note:**

- Multiple addresses in one field need to be separated by a semicolon ( ; ).
- When you here use SmartNames, make sure they resolve to a valid e-mail address.

2. If you want, add extra e-mail address(es) in the **Cc** field (copy).

3. If you want, add extra e-mail address(es) in **Bcc** (blind copy). The recipients' e-mail address will not be displayed to the receiver.

4. Enter an e-mail **Subject**.

There are many SmartNames that can summarize the context of this message. An example:

Please check the attached file for job " [Job Name] ". Please mind its due date: [Job Due Date] - [Job Due Time] .

5. **From:**

By default, **Task Owner** properties will be used to set the 'From' mail header, depending on how outgoing mail as sent by Automation Engine is [configured](#).

- If configured to use an SMTP Server, the e-mail address of the Automation Engine user corresponding with the task owner is taken, preceded with the display name of that user.
- If configured to use a Gmail or Exchange mail account, the e-mail address of that account is taken (as this cannot be changed), but it will be preceded with the display name of the Automation Engine user corresponding with the task owner.

When **From** is overruled, the behavior again depends on how outgoing mail is [configured](#):

- If configured to use an SMTP Server, the 'From' mail header is set to reflect what is entered with From.
- If configured to use a Gmail or Exchange mail account, the e-mail address of that account is taken (as this cannot be changed), but it will be preceded with the display name information that can be extracted from what is entered with From.



**Note:** The 'Reply-To' mail header (which cannot be adapted with the task panel) is by default (when From is not overruled) preset to the e-mail address of the Automation Engine user corresponding with the task owner, preceded with the display name of that user. Otherwise, the 'Reply-To' mail header is set to reflect what is entered with From.



**Attention:** The From field requires a valid e-mail address, not just a name, alias or user name.

**6. Enter your Message.**

Combine custom text with SmartNames to add a lot of variable information.

**7. About text encoding:** By default, this task uses the system's local encoding. If you notice unreadable characters when reading an Automation Engine e-mail in your e-mail program (for example Asian characters), you best change the encoding to UTF-8.

This table shows how to enforce specific encodings:

Add this to the Message field:	to...
<code>#set (\$SubjectCharSet="utf-8")</code>	set the encoding of the <b>Subject</b> to UTF-8.
<code>#set (\$ContentType="text/plain;charset=utf-8")</code>	set the encoding of the <b>Message</b> to UTF-8 and use plain text.
<code>#set (\$ContentType="text/html;charset=utf-8")</code>	set the encoding of the <b>Message</b> to UTF-8 and use HTML.
<code>#set (\$AttachmentsCharSet="utf-8")</code>	set the encoding of the <b>file name of the attachments</b> to UTF-8.

**8. If you want to include the task input files, select Attach input files.**

Mind the size limits that your mail server has on attachments.

**9. Select Ignore unresolved smart addressees** if you want the task to continue when an e-mail address is set via a SmartName that cannot be resolved.

Some examples of when this can happen: when a Job Parameter does not exist for this job, when the SmartName has been deleted or when a Workflow Parameter does not exist in this workflow.

**10. In the ticket's menu item 'Advanced', you can set public parameters** if you want users to be able to fill in e-mail settings when they submit files from [Shuttle](#).

Learn more in [Using Public Parameters in Workflows](#) on page 838.

11. Save your ticket. When you used many SmartNames, it will be valid for many situations and workflows.



**Attention:** Self-closing tags are not supported. For example `<br/>` or `<address/>`. When setting up HTML e-mails, you have to use a separate opening tag and closing tag (example `<address> </address>`), or the empty variant (example: `<br>`).

## 6.194. Send PostScript File to Device

---

This task sends a PostScript file to a PostScript device that was configured on the computer of the Automation Engine server.

Use the drop-down list to select the PostScript device you want to output to.

## 6.195. Set Priority

---

This Workflow Control is documented in the chapter [Workflows](#). See [Set Priority](#) on page 824.

## 6.196. Share Job

---

This task is documented in the chapter [Sharing to Collaborate with other AE servers](#) on page 1685. Find a direct link [here](#).

## 6.197. Share Workflow Ticket

---

This task is documented in the chapter [Sharing to Collaborate with other AE servers](#) on page 1685. Find a direct link [here](#).

## 6.198. Sort

---

This Workflow Control is documented in the chapter [Workflows](#). See [Sort](#) on page 825.

## 6.199. Split PDF File (Classic)

---

This task splits multi page PDFs into single page PDFs or PDFs with a specific range of pages. The task also generates a RunList that contains references to all output PDFs.



- **Output in:** Select where you want to output the generated PDFs and the RunList.
- **File Name:** Enter the name of the generated RunList. By default, this is **[File].jdf**.
- **Split Mode:** Choose how you want to split the pages of the input file.
  - **Split Pages:** This mode splits the PDF into individual single page files.
  - **Split In Groups:** This mode splits the PDF into several files having the same number of pages. Enter this number in the field **Group Size**.



**Note:** If the task cannot output files having the same number of pages, the last output file will have less pages. For example if you ask a PDF with 10 pages to split into files of 4 pages, the task will create 2 PDFs with 4 pages and 1 PDF with only 2 pages.

- **Extract Pages:** This mode extracts only the pages that you specify in the field **Page Ranges**. You can specify either single page numbers or page ranges with a hyphen, for example 1–3 to extract pages 1 to 3. You can add multiple numbers and ranges when you separate them by a comma, for 1–3, 7, 14–22.
  - **Output as one multi page document:** Select this if you want to output all of the page ranges as one document.
  - **Output remaining pages:** Select this if you also want to output the pages that you did not include in the field **Page Ranges** as one multi page PDF.
  - **Remaining Pages File Name:** This is where you define the name of those remaining pages.
- **Pages File name:** Define the name of the output files here. You can use some SmartNames that are specific for this field: [Page Label] and [Page Number]. By default the SmartName [Padded Page Number] is proposed.



**Note:** Padded page numbers help sorting files in alphabetical order. For example: a standard page number is 1 as in mango\_1.pdf. Asking a padded page number results in mango\_01.pdf. And when there are more than 99 pages, the padded page number result will be mango\_001.pdf.

- **Copy XMP data:** Enable this option to copy the XMP data of the input file into the output files.

## 6.200. Split PDF File

### Task Options

- **Split Mode:** Choose how you want to split the pages of the input file.

- **Split Pages:** This mode splits the PDF into individual single page files.
- **Split In Groups:** This mode splits the PDF into several files having the same number of pages. Enter this number in the field **Group Size**.



**Note:** If the task cannot output files having the same number of pages, the last output file will have less pages. For example if you ask a PDF with 10 pages to split into files of 4 pages, the task will create 2 PDFs with 4 pages and 1 PDF with only 2 pages.

- **Extract Pages:** This mode extracts only the pages that you specify in the field **Page Ranges**. You can specify either single page numbers or page ranges with a hyphen, for example 1–3 to extract pages 1 to 3. You can add multiple numbers and ranges when you separate them by a comma, for 1–3, 7, 14–22.
  - **Output as one multi-page document:** Select this if you want to output all of the page ranges as one document.
  - **Output remaining pages:** Select this if you also want to output the pages that you did not include in the field **Page Ranges** as one multi-page PDF.
  - **Remaining Pages File Name:** This is where you define the name of those remaining pages.
- **Page File Names:** Define the name of the output files here. By default this combination of SmartNames is proposed: [File]\_[Padded Page Number].[Extension of File] is proposed.



**Note:** Padded page numbers help sorting files in alphabetical order. For example: a standard page number is 1 as in mango\_1.pdf. Asking a padded page number results in mango\_01.pdf. And when there are more than 99 pages, the padded page number result will be mango\_001.pdf.

- **Marks:**
  - **Expand marks:** The marks are not updated but expanded, i.e. they become dead objects in the output files.
  - **Update marks:** The marks are updated and stay marks.

## 6.201. Split XML

---

This task is documented in the chapter [Integrating with External Systems](#). Find a direct link [here](#).

## 6.202. Start Approval Cycle on Share & Approve

---

This task is documented in the chapter [Integrating with Share & Approve](#) on page 1762.

Find a direct link [here](#).

## 6.203. Step & Repeat CAD based (Classic)

This uses a CAD layout file as input file and places graphic files on the different designs in that CAD layout.

This task supports MFG files (Artios Manufacturing files) and CFF2 files.

### 6.203.1. Tab 'General'

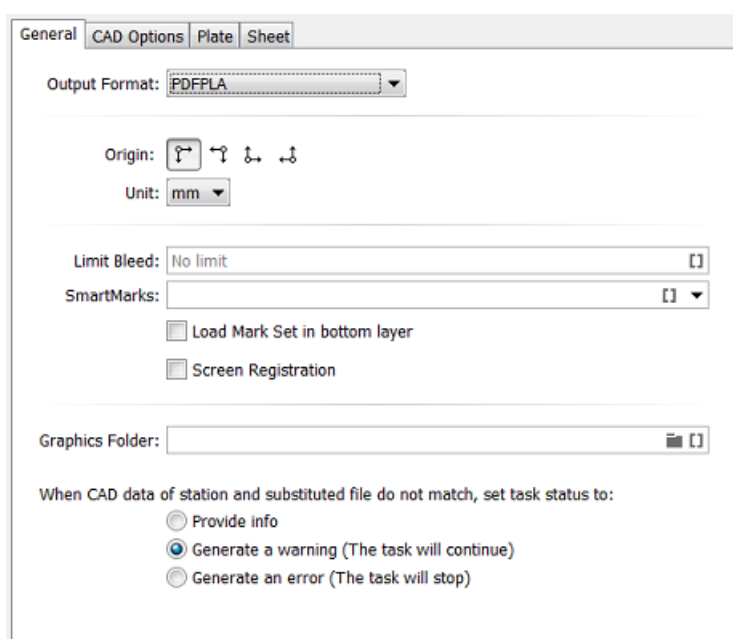

- **Output Format**

- **PDFPLA:** In this format, the placed stations are referenced files, they are not embedded into the layout file. This keeps the layout file small but limits its use to applications that support such external references: Esko editors, Esko RIPs or any next workflows steps in Automation Engine that make use of this smart referencing.



**Attention:** If the input file of this task was a native PDF, this output mode will make the task end in error because a "PDFPLA can only contain references to normalized PDF".

- **Normalized PDF (embed all):** In this format, because all data is embedded, the PDF can be used to exchange this layout file to remote sites that also use tools that read this Esko Normalized data. For example: off-site printers that also use an Esko RIP.

This file format is larger in Mb, however it is important to know that the technique of "PDF forms" is used: each station is only embedded once into the output file. For example if it contains 5 banana labels and 5 lemon labels, the size of the PDF will only be slightly larger than the size of 1 banana PDF plus 1 lemon PDF file.

- **PDF:** This native PDF will have all data embedded and will also use "PDF forms" to optimize its size (as explained here above). Choose this output type PDF when you need to send this data to a non-Esko environment or device.



**Attention:** This output is only advised when the task input file is one or more native PDF(s). The advantage is then that there is no 'on the fly' normalization done on these native PDF stations ; they are untouched and are only placed into the native layout PDF.

This PDF has in its XMP also a description of the contents of its grids, their station names and amounts. Any distortion factor (here named "**Shrink**") will be calculated/executed in the PDF.



**Note:** Choosing this output type disables the options '**Screen Registration**' and '**Include CAD info for Digital Flexo Suite**'.

- Choose the matching icon for the **origin** of the plate.
- Select '**Limit Bleed**' to limit any bleed to a specific distance. The bleed mask is created by spreading the die shape.



**Note:** Learn more about what happens when bleed from panels overlaps in [Bleed and overlap](#) on page 296 and in [Bleed Overlap Priority decided by ArtiosCAD Artwork Panels](#) on page 297.

- Add **SmartMarks** by selecting a SmartMark set from the drop-down list. Or use a SmartName to select it.

Select '**Load Mark Set in bottom layer**' if you want to make sure the marks are positioned in the bottom layer, to make them appear 'behind' the graphics.

- **Screen Registration:** When selected, the origin of the screening will be reset for each station on the layout. This guarantees that the exact same screening will be applied for each station. This is for example required when printing stamps. When not selected, screening will be done continuously throughout the complete layout.



**Attention:** This option defines an attribute in the PDF that is only supported by **Imaging Engine** or **FlexRip**. It is ignored by any other RIP..



**Attention:** Screen registration is not available when you choose the output format **PDF**.

- **Graphics Folder.** Define the folder where the task can find the graphic files that should be repeated (a.k.a. 'stations').
- **When CAD data of station and substituted file do not match, set task status to:**
  - **Provide info**
  - **Generate a warning (the task will continue).**
  - **Generate an error (the task will stop).** The task will not create an output file.

## 6.203.2. Tab 'CAD Options'

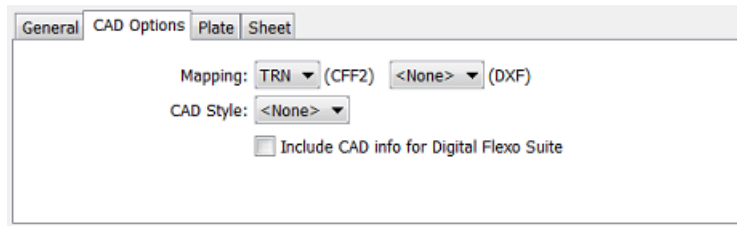

Both **Mapping** and **CAD Style** are options you can define in the Esko Editors.

- **Mapping:** When the CAD file is a CFF2 or DXF file, you here select the set of mapping rules. These rules map line styles (cut, crease, bleed), layer names and color numbers onto ArtiosCAD line types. These sets of mapping rules can be created in Esko PackEdge or Plato. Learn more in [their user documentation](#), more specifically in their section on placing files (PackEdge) or on importing CAD data (Plato).
- The **CAD Style** changes the appearance of the (imported) ArtiosCAD type lines.



**Note:** This CAD Style is only applied on lines from the design (ARD) that was stepped in the layout file (MFG). Lines manually drawn next to the placed designs (the so called "objects at layout level") will always be ignored by the task.

The styles you can select here were also created in PackEdge or Plato. Learn more in [their user documentation](#), more specifically in the section on placing ArtiosCAD files, and the option for "CAD Style".

- **Include CAD info for Digital Flexo Suite:**

If you are using the Esko [Digital Flexo Suite](#) (DFS), select this option to add the technical inks data into the header of the output file (this is usually the cut and crease lines). This data is then visible in the Esko Bitmap Viewer and also embedded in the LEN files created by an Esko RIP.

The DFS can export this information into ACM files for an Kongsberg cutting table. In Esko PlatePatcher workflows, this information can be used to print onto the plastic sheet where the pieces of flexo plate are re-assembled. These technical lines can also represent text that is then added onto the (back of the) flexo plates, using a pen on the Kongsberg table.



**Attention:** This option is disabled when you choose the output format (native) **PDF**.

### 6.203.3. Tab 'Sheet'

The sheet is the substrate that this layout will be printed on.

#### Sheet Size

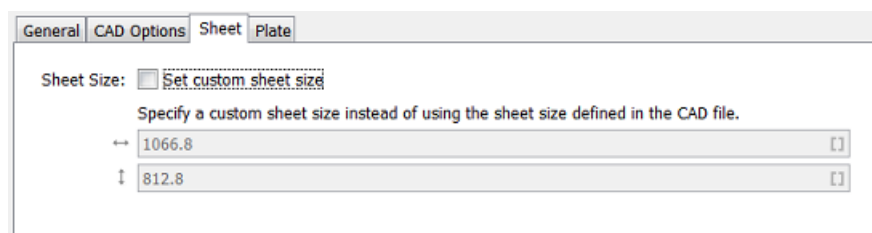

- **Set custom sheet size:** Select this when you do not want to use the size that is defined in the CAD file. Then enter its size below.

### 6.203.4. Tab 'Plate'

The sheet size is automatically extracted from the CAD template but neither Artios MFG nor CFF2 files have a notion of 'plate'. As a result, the plate size and the position of the sheet on the plate have to be specified in this **Plate** tab.

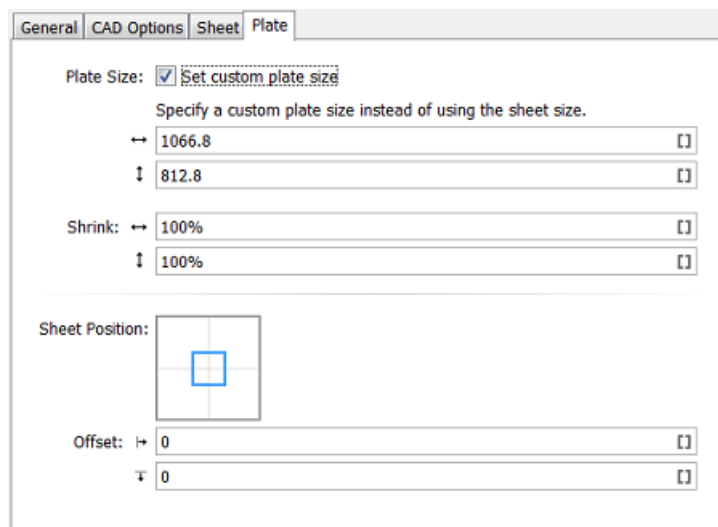

- **Plate Size** : Select **Set custom plate size** when the plate size needs to be different than the sheet size. Then enter your custom plate size below (and possibly also the sheet position and offset).
- If you want, enter horizontal and/or vertical **Shrink** values (in percentage) to compensate for printing distortion (especially in Flexo).  
The default value is 100, both horizontally and vertically, which means no distortion compensation. Learn more about when and how they are applied in the topic 'shrink' [on this page](#).
- Define the **Sheet Position** by clicking or dragging the sheet (inner rectangle) to its position versus the plate (outer rectangle).
- **Offset**: When enabled, add a H and/or V offset of the sheet versus the plate.

## 6.204. Step & Repeat CAD based

### Concept

This task creates a final sheet layout containing a number of copies of 1 or more designs. For example: a layout with 10 copies of a small box and 5 copies of a large box.



**Note:** This task uses Esko's NDL (PDF+) based graphic kernel. It aims to replace the tasks [Create Sheet Layout \(Classic\)](#) on page 289 and [Step & Repeat CAD based \(Classic\)](#) on page 453.

This task accepts various input file types. It outputs PDF+ file(s).

### Input and Output File Types

- **Input file types**

The task accepts multiple input files.

The task allows different types of input files:

- PDF(+)
- Normalized PDF
  - without CAD object info
  - with CAD object info. This CAD object could have been added in Adobe Illustrator, ArtPro, ArtPro+, PackEdge or by the task [Load Structural File \(Classic\)](#).
- XML. An XML RunList allows more control over page selection, placing quantity and more.



**Note:**

- When one or more of the input files are 2-sided PDF files, then duplex is performed automatically.
- It is possible to mix 1-sided and 2-sided documents ; some input files can then define both front & back, and some can have only the front side.
- PDFSTA files are not supported.
- When the input PDF is a Product then it is possible - even for single-page files - to specify a side (front/back) and generate duplex output. This functionality is also mentioned later in this document when specifying *XML input* (it does require the input file to be a product (part) file, but it is not important if the file is defined by file name or Product ID).

- **Output file type**

- PDF+ file(s)

### 6.204.1. Tab 'General'

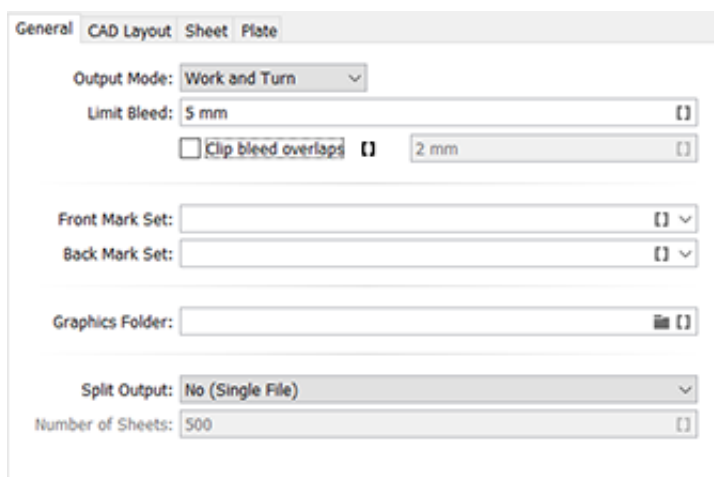

- Output **Mode**: You can choose to

- **Work and Turn** (rotate over a vertical axis) or **Work and Tumble** (rotate over a horizontal axis).



**Note:** In order to make a CAD sheet with a front and a back, you need a multi-page PDF file. The first page is placed on the front, the second on the back.

- Or you can choose to output only one side: **Front Only** or **Back Only - Turn** or **Back Only - Tumble**.
- **Limit Bleed:**
  - When using a **CF2 / MFG template**, this value is the actual value of bleed that is applied (like it is visible in ArtPro+ "Clip bleed at").
  - If the job is specified **using an XML file** and the XML contains a bleed value, then this Limit Bleed value is used to clip the value from the XML (the smallest of these two is used). If the Limit Bleed value is empty then the value from the XML is used without modification.
  - When using a **PDF template**, this value means the creation of an extra clipping path on top of the bleed that is provided in the template. When this Limit Bleed value is empty, no additional clipping path is created.

So if you use an **MFG template and there is no job XML** (or a bleed key is missing in the XML), then the bleed is based on this Limit Bleed value. **If it is left empty it is interpreted as 0.0** and so there will be a tight clipping mask.



**Note:** When using a SmartName, the resolved value should contain a number and a unit ((case insensitive): mm, cm, in, inch, mil, point, pt. When no unit is specified, the default value mm is taken.

- **Front Mark Set / Back Mark Set:** Select a Dynamic Mark set to be put on the front or back side of the layout.



**Note:** Only Dynamic Marks created in ArtPro+ are supported. SmartMarks or Dynamic Marks from DeskPack can not be used.

The marks in the output PDF of this task will be 'live' objects (except in VDP mode), which means they are still editable when you open the output file in ArtPro+.



**Note:** Unlike the other S&R tasks (and excl. the 'Classic' ones), this task does not offer the "optimize output" as a separate option in the ticket (as described in the page of the as it exists in the task [Add Dynamic Marks](#)).

- **Graphics Folder:** This is the folder where the task searches the graphic files. This option is only applicable when the input mode of the task is XML and when the XML does not offer a full absolute path (only a partial path or only the name of the input file). Learn more in [Using XML as Input File](#) on page 466.
- **Split Output File:** This option helps to process large jobs produced by VDP input. A huge PDF file can be difficult to process by RIPs. Splitting it into several smaller ones is then advised.
  - When having selected **On Number of Sheets**, define the maximum of sheets (pages describing a layout) that this output PDF may have.

Learn about the VDP mode of this task at the bottom of the page [Step & Repeat CAD based](#) on page 456.



## 6.204.2. Tab 'CAD Layout'

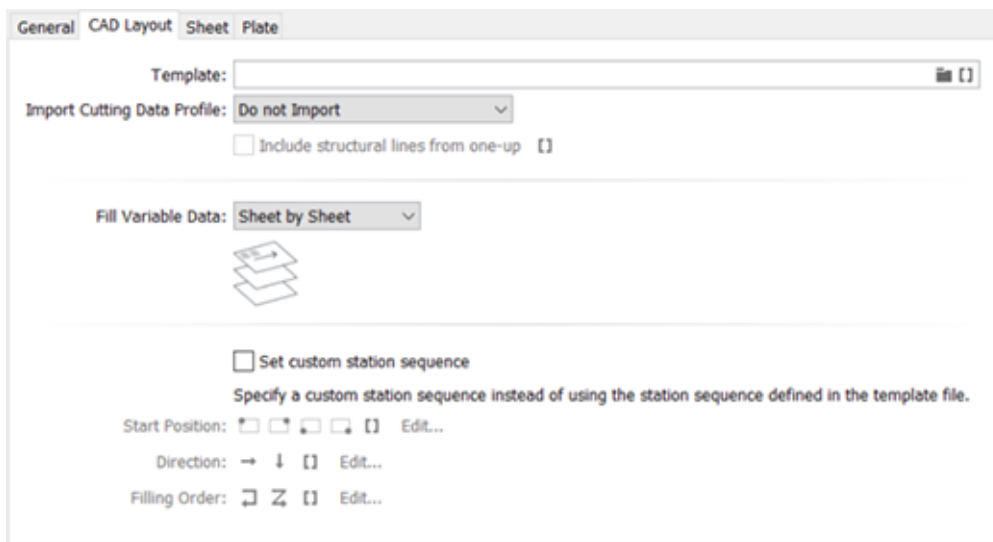

- **Template:** Select an MFG, CF2 or PDF+ template file.



**Note:** A PDF+ file can serve as a template when it was a CAD file that you can open in ArtPro+ (an MFG for example), where you can add marks and where you can define bleed and overlaps. In other words: when it is not a PDF+ file with grids (grid objects serve tabular layouts).



**Note:** Using outputs from this task as CAD layout templates is not supported.

- **Import Cutting Data Profile:** Select the type of cutting data from an MFG or CF2 template that needs to be imported into a processing step layer (named "structural lines").
  - **Do Not Import**
  - **Import Cut & Crease**
  - **Import Cut, Crease & Dimensions**
  - **Import All**

**Include structural lines from one-up:** When using an MFG template and importing cutting data, select this to also include the structural lines from the one-ups in the resulting layout file. When not selected, only the cut and crease line types of the one-up will be included

- **Fill Variable Data:** Define how, in VDP mode, the stations should be filled: **Sheet by Sheet** or **Stack by Stack**.

Learn about the VDP mode of this task at the bottom of the page [Step & Repeat CAD based](#) on page 456.

- Select **Set custom filling order** to specify a filling order that is different than the one defined in the selected template file.
- The filling order is defined by selecting a **Start Position**, **Direction** and type of **Filling Order**. Learn more about using SmartNames to define these buttons in [SmartNames of Parameter Values](#) on page 729.



**Note:** The sequence of the designs is determined by taking the center points of the designs and sorting these in rows and columns. Keep in mind that designs with different sizes, or layouts with staggered designs can result in more rows or columns than expected.

### 6.204.3. Tab 'Sheet'

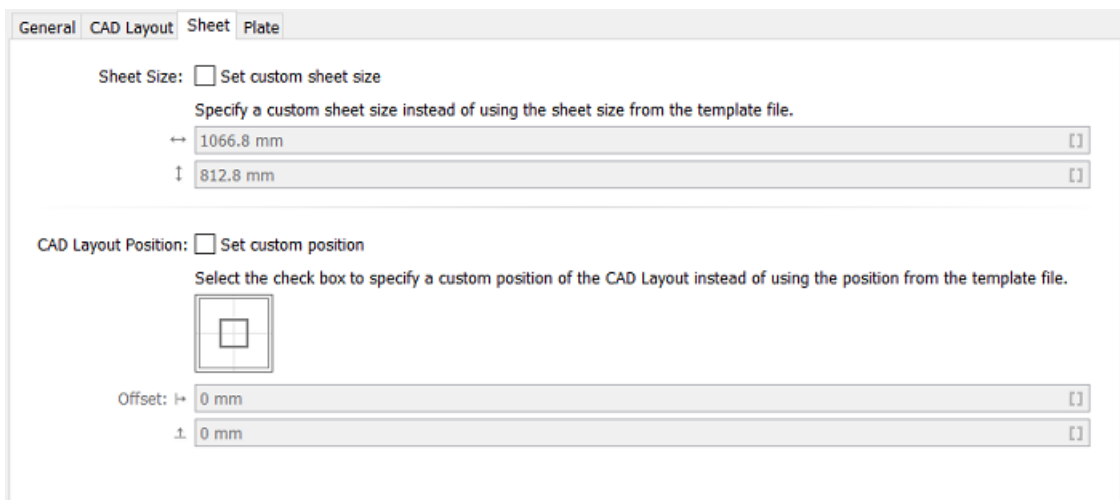

- If you want to use a custom sheet size instead of the **Sheet Size** defined in the template file, then select **Set custom sheet size** and enter its dimensions.
- **CAD Layout Position:** You here position the content of the CAD Layout template versus the sheet. This content is defined by the bounding box of all cutting and creasing lines from the template.  
Select **Set custom position** if you want to use a different position for the CAD Layout than the one defined in the template file.
  - **Position on Sheet:** Click or drag the inner square (the CAD Layout) in a position versus the outer square (the sheet).
  - **Offset:** Define by how much the CAD Layout should be offset from the sheet corner, horizontally and vertically.

### 6.204.4. Tab 'Plate'

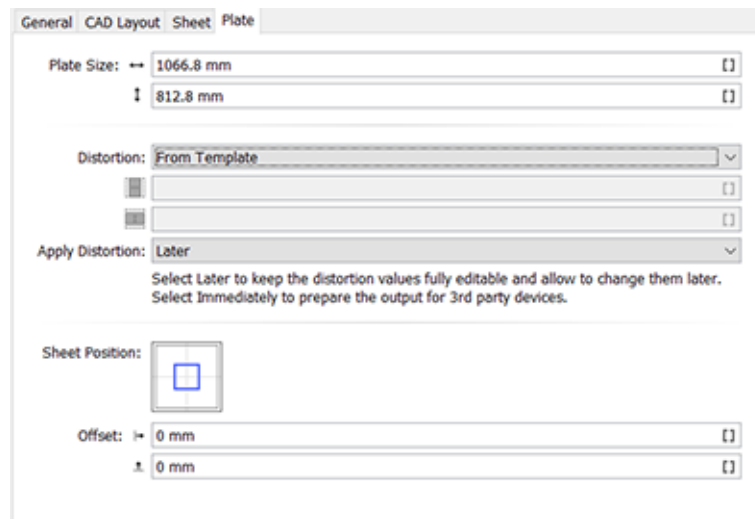

The sheet size can be automatically extracted from the CAD template but neither an ArtiosCAD MFG file nor a CFF2 file have a notion of 'plate'. As a result the plate size and position of the sheet on the plate have to be specified in this **Plate** tab.



- **Plate Size:** Specify the plate's horizontal and vertical size.
- **Distortion:**
  - **Custom:** To compensate for distortion on the output device or press, you can add vertical and horizontal distortion values.  
When using a SmartName to decide this choice, its value should resolve to `custom`; any other value will select `From Template`.
  - **From Template:** Select this to make the task use the distortion values present in the selected template file.
- **Apply Distortion:** When should it be applied?
  - **Later:** The task makes no changes to the file's page boxes but only adds the requested value in the output file's meta data. When you open that file in ArtPro+ you can see it mentioned in the document setup dialog. You can still change these values.
  - **Immediately:** The requested distortion is executed on the file's page boxes and objects. Also the marks and grids are expanded. This is advised when sending to the output PDF to 3rd party devices.  
When using a SmartName to decide this choice, its value should resolve to `immediately`; any other value will select `Later`.
- **Sheet Position:** Click and drag the inner square (the sheet) to the right position on the outer square (the plate) to position the sheet on the plate.
- Define any extra horizontal and vertical sheet **Offset**.



**Tip:** When using SmartNames, make sure they return a value that the field expects. For example a SmartName in the field 'Plate Size' should return a number.

### 6.204.5. Positioning of a One-up onto a Station

To decide how to position a one-up onto the station in the layout, the task follows these principles:

Input file	Template type	task behavior
XML	-	<p>When, in the XML, "DieShape" is set to</p> <ul style="list-style-type: none"> <li>"DEFAULT" then the CAD object in the specified one-up PDF is used.</li> <li>the name of a spot color separation that could be used as a station, then that shape is used to position.</li> <li>set to "TRIMBOX" or "BORDERS", it will use the trim box of a station as positioning shape</li> </ul> <p>Learn more in the dedicated page <a href="#">Using XML as Input File</a> on page 466.</p>
PDF	MFG / PDF / CF2	<p> <b>Note:</b> The task's behavior is the same as when in an XML the "DieShape" is set to "DEFAULT".</p> <ol style="list-style-type: none"> <li>1. First, positioning is based on CAD object in the one-up PDF.</li> <li>2. When no CAD object is found in the one-up PDF, positioning is done based on trim box versus the bounding box of the cut and crease lines of a station. (The trim box can be slightly larger than its station, this due to bleed).</li> <li>3. When no matching trim box is found, the task will fail.</li> </ol>
Normalized PDF	MFG / PDF / CF2	<p>A normalized PDF can include a link to a one-up ARD file. When the dimensions match, it will be used for positioning.</p> <p> <b>Note:</b> The task output S&amp;R file will contain the embedded ARD with a name coming from MFG, not the name mentioned in the input normalized PDF).</p>

### 6.204.6. Distribution of One-ups over the Layout

The goal of the distribution algorithm in this task is to produce requested quantities with a minimal number of printed sheets to save substrate.

How are input files distributed over the CAD layout?

- **When the input file of the task is an XML file**, the task will - for each specified graphic - look for an XML element `Quantity`.

Quantity can be specified in these ways:

- By a specific **number** ( `<Quantity>10</Quantity>` ).



**Important:** Even when a specific quantity is given (and no 'maximum' is used for another station), the task considers these numbers as requests: The task will still try to fill the sheet and the task will also consider requested quantities from other stations. This means the resulting quantity can be slightly different.

- By requesting a **maximum** ( `<Quantity>Maximum</Quantity>` ). In this case, the task will place the referred PDF file as many times as possible. When more than one PDF file has the quantity element set to maximum, the task will distribute the referred PDF files equally.

- The XML can also **combine** files with a specific quantity with one or more files with a quantity set to maximum.



**Note:** The task will stop in error in these cases:

- When (at least one instance of) an input design cannot be placed. This could be due to a wrong size or a wrong design name.
- When there are empty (unfilled) positions (stations) in the template.
- When all suitable positions are already filled up, i.e. there are more input graphics files than available positions.

- **When the input files of this task are a set of PDF files**, the task will consider all PDFs to be set to maximum quantity, so the provided input files will be distributed evenly onto the provided CAD layout.

When the number of available stations cannot be divided by the number of input files (for example 9 stations and 2 PDF files), the task will automatically distribute the remaining stations.

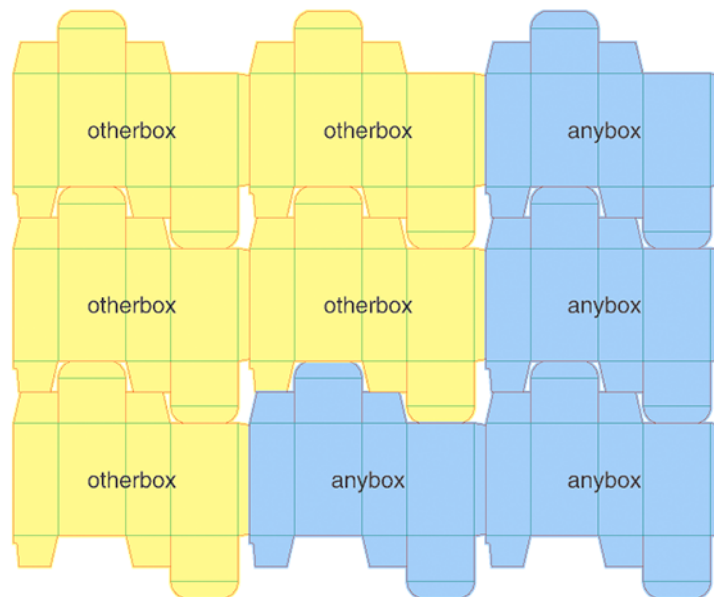

**Note:** When the CAD file contains different designs (different types or sizes of boxes), the graphics will only be distributed on the corresponding (fitting) designs (see [Positioning a One Up graphic onto a Station](#) on page 294).

### 6.204.7. About Bleed and Overlapping Bleed

When the one-up graphics contains bleed, this bleed will be used around the die line, limited by the value in **Limit Bleed** (in the [General tab](#)).



**Note:** Everything outside the die line is considered to be bleed. Bleed zones without content will knock out when overlapping. Overlaps can only work well if a correct bleed limit is applied.

The bleed overlapping behavior in this task is identical to the one in ArtPro+ and is also described below.

- Using a PDF+ layout template has the advantage that, during its creation in ArtPro+, the user can manually make the right bleed decisions. This task will respect and execute these decisions in the template ; it will not re-calculate bleed.

The only thing this task can do is limit the existing bleed (make it smaller but it will not change the bleed directions nor make bleed bigger).



**Note:** Using outputs from this task (layout PDF) as a CAD Layout template in this task is not supported.

- When using an MFG layout template, the task will make decisions based on the size of neighboring panels, possibly overruled by ArtiosCAD 'Allow bleed' flags..

### Bleed overlap situations

When the bleed of two stations overlaps, you can have these situations:

- There is a gap** between the panels of the two neighboring stations.

In this case, centerline overlapping is applied: the bleeds from both stations touch on the centerline of the gap.

- There is no gap**, the station panels are touching ('common cut').



**Note:** When deciding if a station is touching another station, minor tolerances are taken into account to cope with small inaccuracies in the die cut file.

When the layout is based on a CAD template, the behavior is decided in this order:

- Where **Panel Tags** are defined in the one-up (in ArtPro+), and the layout is a PDF+ template from ArtPro+, the bleed direction is derived from the panel tag. When the option **Limit Bleed** has a value, it only makes an additional mask on top ; this can limit the bleed further but cannot make it bigger.

Learn more below in [Bleed Overlap decided by ArtPro+ Panel Tags](#).

- Where no Panel Tags are defined, but **'Allow Bleed' flags** are set in the artwork panels of the ARD file, and the layout template is an MFG, the bleed direction will be based on the 'allow bleed' flags.

Learn more below in [Bleed Priority decided by ArtiosCAD Artwork panels](#).

- When there are no Panel Tags nor Bleed Flags, the bleed direction will be based on the **size of the panels**.
  - The biggest panel will overlap the smaller panel (situation A in the example below).
  - When the panels are the same size, centerline overlapping is applied (situation B in the example below).

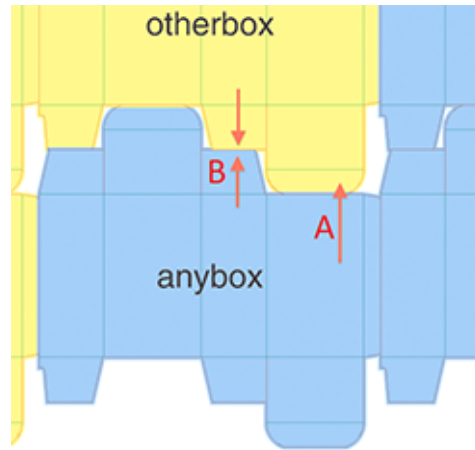

### Bleed Overlap decided by ArtPro+ Panel Tags

In ArtPro+, **Panel Tags** allow to store bleed behavior in your one-up, which will be used when placing the one-up in an MFG or CF2 based Step & Repeat.

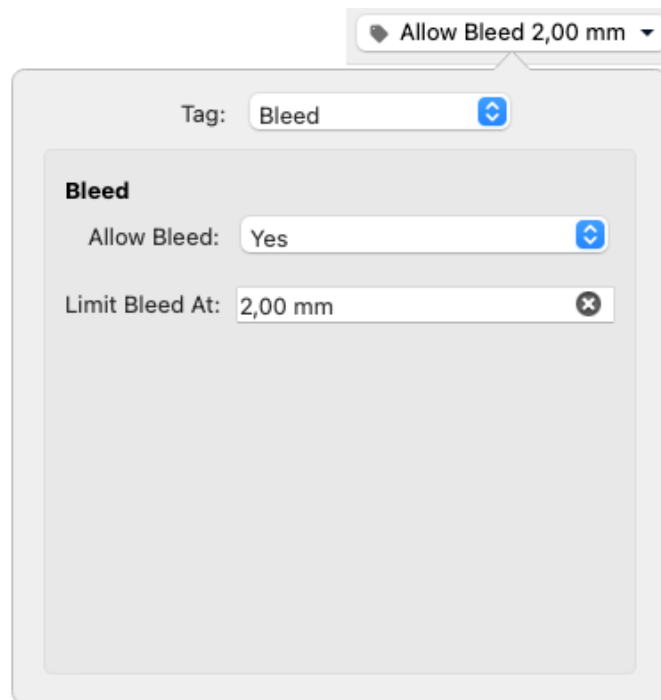

Learn more in the [ArtPro+ user guide](#).

### Bleed Overlap Priority decided by ArtiosCAD Artwork Panels

The priority in bleed overlap can be automatically decided in case the layout is an MFG and in case there are common knives (i.e. no gutters, so areas where 2 panels/flaps touch). The decision is then based on how the ArtiosCAD user defined the bleed direction for those specific panels.

In ArtiosCAD, a panel can be defined as an **'artwork panel'** and an artwork panel can have an **'Allow bleed'** property. A panel that is set to allow bleed is considered as having a minor priority and it can receive bleed when it touches another panel marked as major priority (where **'Allow bleed'** was not defined or turned off). In the case 2 minor panels are touching, the bleed will be truncated to the centerline, which is the default behavior, like in areas where there are gutters (i.e. no common knives).



**Note:** This behavior applies to all Step & Repeat tasks using an MFG layout (including in classic editor Esko Plato).

**Overview of all Possible Situations:**

- In case there is a gutter: always centerline truncation.
- In case there is no gutter between 2 panels (gutter = 0), the following overview applies:

**Table: Smart Flapping**

Panel 1	Panel 2	Bleed Action
Not an artwork panel	Not an artwork panel	Compare size of Panel 1 and Panel 2. If size difference > 10%, then large one bleeds into smaller one, otherwise centerline is used
Not an artwork panel	Artwork panel with allow bleed = 0	Centerline (i.e. no bleed as the gutter = 0)
Not an artwork panel	Artwork panel with allow bleed = 1	Panel 1 bleeds into Panel 2
Artwork panel with allow bleed = 1	Artwork panel with allow bleed = 1	Centerline (i.e. no bleed as the gutter = 0)
Artwork panel with allow bleed = 1	Artwork panel with allow bleed = 0	Panel 2 bleeds into Panel 1
Artwork panel with allow bleed = 0	Artwork panel with allow bleed = 0	Centerline (i.e. no bleed as the gutter = 0)
Artwork panel with allow bleed = 0	Artwork panel with allow bleed = 1	Panel 1 bleeds into Panel 2

## 6.204.8. Using XML as Input File

### Concept

When the business system (MIS, ERP) provides an XML description, this task can fully automate the folding carton step & repeat process.

When using XML input file(s), the task supports 2 modes:

- **The <Job> element mode** is an older v18.0 compatible mode supporting the XML format. Advantage of this mode is that you can use the **Product ID**. This is used for example in flexo printing. Learn more below.
- **The <RunList> / Dynamic mode** is compatible with the XML used in the Step & Repeat tasks (excl. the older 'Classic' ones). Advantage of this mode is that you can specify a page range (in case your input file is a multi-page file). This is used for example in VDP. Learn more below.



### Specification of the Mode based on the Element <JOB>

In the v18.0 compatible mode, the task scans the XML file for elements called <JOB>. Multiple <JOB> nodes are allowed when these are placed under a <JOBS> node.



**Attention:** All XML elements are case sensitive. For example, the element <JOB> must be in capital letters.

- An example:

```
<?xml version="1.0" encoding="UTF-8"?>
- <JOB>
  <FileName>\\homer\beou_container\beou_CAD_demo\Input\demo\anybox.pdf</FileName>
  <Quantity>7</Quantity>
  <Bleed>2.0</Bleed>
</JOB>
```

- It's also possible to combine multiple graphics in the XML file. In that case, multiple <JOB> elements are gathered in one <JOBS> element. An example:



```
<?xml version="1.0" encoding="UTF-8"?>
- <JOBS>
  - <JOB>
    <FileName>\\homer\beou_container\beou_CAD_demo\Input\demo\otherbox.pdf</FileName>
    <Quantity>2</Quantity>
    <Bleed>2.0</Bleed>
    <Page number="1"/>
  </JOB>
  - <JOB>
    <FileName>\\homer\beou_container\beou_CAD_demo\Input\demo\anybox.pdf</FileName>
    <Quantity>7</Quantity>
    <Bleed>2.0</Bleed>
    <Page number="1"/>
  </JOB>
</JOBS>
```

- A Job element can also be empty. This position will become an empty station. This is sometimes used to save ink. Example of a layout station that will be remain empty:

```
<JOB>
</JOB>
```

Each <JOB> element will create a station according to its sub elements:

XML Element	Description
FileName (mandatory)	URL of the graphics. Both URLs and UNC paths are supported. Both absolute URLs and relative URLs are supported. In case the URL is relative, the <b>Graphics Folder</b>

XML Element	Description
	<p>specified in the ticket is used to resolve the URL of the graphics. Only one of either <b>FileName</b> or <b>ProductID</b> may be specified. Some examples:</p> <pre data-bbox="475 389 1434 443">&lt;FileName&gt;file://myserver/myfolder/mygraphics.pdf&lt;/FileName&gt;</pre> <pre data-bbox="475 472 1434 526">&lt;FileName&gt;\\myserver\myfolder\mygraphics.pdf&lt;/FileName&gt;</pre> <pre data-bbox="475 555 1434 609">&lt;FileName&gt;mygraphics.pdf&lt;/FileName&gt;</pre> <pre data-bbox="475 638 1434 692">&lt;FileName&gt;myfolder\mygraphics.pdf&lt;/FileName&gt;</pre>
<p><b>Product ID</b> (mandatory if <b>FileName</b> is not used)</p>	<p>ID of the Product to use for the graphics. Only one of either <b>FileName</b> or <b>ProductID</b> may be specified.</p> <ul style="list-style-type: none"> <li>• If a product contains multiple parts, the first part is used. The second part will be used (if present) as back side graphic.</li> <li>• When a product has 2 parts, you can use a Product Part parameter to define which side of the sheet this part should go on. To do this, name the Product Part parameter 'side' and as value, and give it one of these values: <ul style="list-style-type: none"> <li>• '1' or 'front' or 'recto'</li> <li>• '2' or 'back' or 'verso'</li> </ul> </li> </ul>
<p><b>Quantity</b></p>	<p>Number of times the graphics needs to be placed. Allowed values are either a number or the keyword "<b>Maximum</b>" (the default value / case insensitive / can be abbreviated to "<b>Max</b>"). In case multiple graphics are using 'quantity = maximum', they will be evenly placed on the number of matching placeholders.</p> <div data-bbox="469 1234 1426 1352" style="border: 1px solid #ccc; padding: 5px; margin-bottom: 5px;">  <b>Note:</b> First the graphic(s) with fixed quantities are placed, then the graphic(s) with 'maximum' quantity are evenly distributed over the remaining designs. </div> <div data-bbox="469 1368 1426 1451" style="border: 1px solid #ccc; padding: 5px;">  <b>Note:</b> Learn more about how the task manages requested quantities in <a href="#">Distribution of One-ups over the Layout</a> on page 462. </div>
<p><b>DieShape</b></p>	<p>Ink name representing the die line of the graphics. Allowed values:</p> <ul style="list-style-type: none"> <li>• the name of a spot color,</li> <li>• 'TRIMBOX' (or 'BORDERS') will use the trim box of the PDF graphic.</li> <li>• 'DEFAULT' will search for a CAD object inside the PDF file. When no CAD object is found, the trim box will be used. This also the default value of this element.</li> </ul>
<p><b>Bleed</b></p>	<p>The amount of bleed allowed outside the die shape. Sets a bleed mask, in mm, starting from the die line. When no bleed is specified, no bleed mask will be applied.</p>
<p><b>Page number</b></p>	<p>Select a specific page from the specified PDF graphic. If no page is specified, all pages of the graphics file will be loaded.</p>

**Specification for the <Runlist> Mode - compatible with Step & Repeat tasks (= excluding the 'Classic' S&R tasks)**



In this more recent **Step & Repeat** compatible mode, the task will scan the XML file for elements called <RunList>, which contain one or multiple <RunListItem> nodes.

A <RunListItem> node consists of the following sub-nodes:

Node	Description
FileName	URL or UNC of the PDF graphic to be placed. Relative URL's are allowed, the 'Graphics Folder' will then contain the base path.
Repeats	Number of copies required for this graphic. Allowed values are either a number or the keyword "Maximum" (case insensitive, can be abbreviated to "Max").
FirstPage	Number indicating the first page to be used. Learn more in <a href="#">Specification of RunList XML in Step &amp; Repeat tasks (= excl. the Classic ones)</a> on page 496.
LastPage	Number indicating the last page to be used. Learn more in <a href="#">Specification of RunList XML in Step &amp; Repeat tasks (= excl. the Classic ones)</a> on page 496.

**Extra XML Parameter when working Front and Back Graphics**

Table: Back side handling in XML (all optional)

XML Element	Description
BackGraphic	<p>UNC (or URL) of the PDF file to be used as back side. Example:</p> <pre>&lt;BackGraphic&gt;file://myserver/myfolder/mybackgrphic.pdf&lt;/BackGraphic&gt;</pre> <p> <b>Note:</b> No page selection is possible for the back graphic. Only the first page of the back graphic PDF is used)</p> <p> <b>Note:</b> Either this element <code>BackGraphics</code> is used to define the background or it is defined by the a product part parameter 'side'. These 2 methods serve the same purpose but cannot be combined.</p>

Other nodes as listed above (DieShape, BackGraphic) are optional.

## 6.205. Step & Repeat Tabular (Classic)

This task creates a step & repeat layout where the stations (one-ups) do not overlap ; their bounding boxes do not intersect.

In this ticket, data can be entered

- manually, entering numeric values, including calculations
- using SmartNames. These can be
  - Formulas.** For example [VPLATE]. The names of these formulas are similar to those used in Esko's classic editor Plato.

- any other types of SmartNames. These can get their values from (job) parameters within Automation Engine or they could retrieve these values from external databases, by doing SQL queries. See an example in [here](#). Learn more in [Database Query SmartNames](#) on page 692.



**Note:** Some ticket fields only accept SmartNames of the category 'Step & Repeat' whereas others also allow 'Global' SmartNames. Learn more in [SmartName Categories](#) on page 646.

### Comparing this 'Classic' task to the newer version (with the same name)

Another tabular S&R task was created later than this one, mainly to serve workflows to digital presses. Here 's a summary comparing their unique features:

- This **Step & Repeat Tabular (Classic)** task:
  - The marks you can add need to be **SmartMarks** (created in Esko's classic editors PackEdge or Plato)
  - Offers **formulas** to specify the layout
  - Outputs **various output formats**.
- The [Step & Repeat Tabular](#) task:
  - The marks you can add need to be **Dynamic Marks** (created in the [Adobe Illustrator Plug-in 'Dynamic Marks'](#))
  - Does not offer formulas to specify the layout
  - Tailored for digital presses and/or VDP workflows
  - Outputs **Native PDF**.

## 6.205.1. Tab 'General'

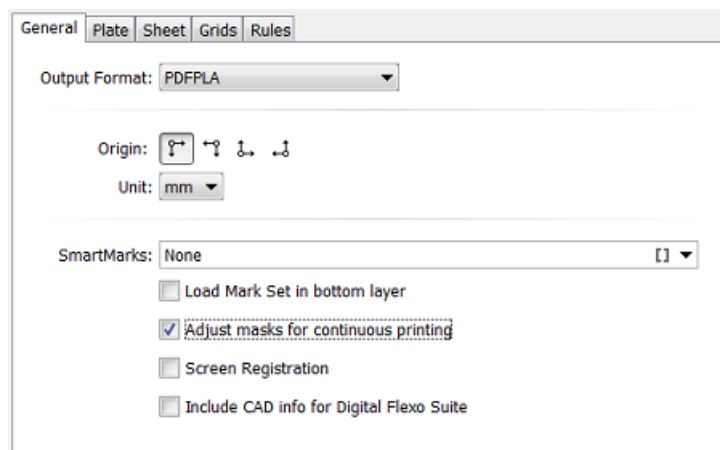

- **Output Format**
  - **PDFPLA:** In this format, the placed stations are referenced files, they are not embedded into the layout file. This keeps the layout file small but limits its use to applications that support such

external references: Esko editors, Esko RIPs or any next workflows steps in Automation Engine that make use of this smart referencing.



**Attention:** If the input file of this task was a native PDF, this output mode will make the task end in error because a "PDFPLA can only contain references to normalized PDF".

- **Normalized PDF (embed all):** In this format, because all data is embedded, the PDF can be used to exchange this layout file to remote sites that also use tools that read this Esko Normalized data. For example: off-site printers that also use an Esko RIP.

This file format is larger in Mb, however it is important to know that the technique of "PDF forms" is used: each station is only embedded once into the output file. For example if it contains 5 banana labels and 5 lemon labels, the size of the PDF will only be slightly larger than the size of 1 banana PDF plus 1 lemon PDF file.

- **PDF:** This native PDF will have all data embedded and will also use "PDF forms" to optimize its size (as explained here above). Choose this output type PDF when you need to send this data to a non-Esko environment or device.







**Attention:** This output is only advised when the task input file is one or more native PDF(s). The advantage is then that there is no 'on the fly' normalization done on these native PDF stations ; they are untouched and are only placed into the native layout PDF.

This PDF has in its XMP also a description of the contents of its grids, their station names and amounts. Any distortion factor (here named "**Shrink**") will be calculated/executed in the PDF.



**Note:** Choosing this output type disables the options '**Screen Registration**' and '**Include CAD info for Digital Flexo Suite**'.

- **Origin:** Define the point of origin from which the step & repeat is to be built.

 (top left),  (top right),  (bottom left),  (bottom right).

- **Unit:** Select a unit (mm or inch) to be used for all numeric fields in this task.
- **SmartMarks:** If you want to add marks to the step & repeat, select a SmartMarks set from the drop-down list or use a SmartName.
- Select '**Load Mark Set in bottom layer**' if you want to make sure the marks are positioned in a newly created bottom layer, so that they appear 'behind' the graphics.

- **Adjust masks for continuous printing:**

When not selected, the top and bottom rows can have more bleed (top- and bottom bleed) compared to graphics that occur in the middle of the layout.

When selected, the bleed of the top and bottom row of graphics will be truncated in the same way as on the rows in the middle of the layout (i.e. truncate the bleed of the top and bottom row of graphics as if there is a continuous set of rows of graphics). This is required to enable continuous printing (around the drum).

- **Screen Registration:** When selected, the origin of the screening will be reset for each station on the layout. This guarantees that the exact same screening will be applied for each station. This is for example required when printing stamps. When not selected, screening will be done continuously throughout the complete layout.



**Attention:** This option defines an attribute in the PDF that is only supported by **Imaging Engine** or **FlexRip**. It is ignored by any other RIP..



**Attention:** Screen registration is not available when you choose the output format **PDF**.

- **Include CAD info for Digital Flexo Suite:**

If you are using the Esko *Digital Flexo Suite* (DFS), select this option to add the technical inks data into the header of the output file (this is usually the cut and crease lines). This data is then visible in the Esko Bitmap Viewer and also embedded in the LEN files created by an Esko RIP.

The DFS can export this information into ACM files for an Kongsberg cutting table. In Esko PlatePatcher workflows, this information can be used to print onto the plastic sheet where the pieces of flexo plate are re-assembled. These technical lines can also represent text that is then added onto the (back of the) flexo plates, using a pen on the Kongsberg table.



**Attention:** This option is disabled when you choose the output format (native) **PDF**.

## 6.205.2. Tab 'Plate'



**Note:** In the entry fields of this and the next tabs, click '+' to open the SmartNames dialog. Alternatively, right-click the field and directly choose a SmartName or formula from the offered lists.

- **Plate Size:** Enter the horizontal and vertical plate size value, formula or SmartName. Learn more in [Using Formulas](#) on page 480.
- **Shrink:** If you want, enter a shrink value, formula or SmartName. Learn more about when and how shrink is applied in [the page about the Create CAD Sheet task](#).
- **Sheet Position:** Position the sheet on the plate by moving the sheet (inner rectangle) versus the plate (outer rectangle).
- **Offset:** Enter a value, formula or SmartName.

### 6.205.3. Tab 'Sheet'

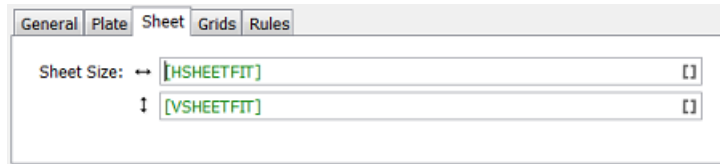

- **Sheet Size:** Enter the horizontal and vertical sheet size value, formula or SmartName. Learn more in [Using Formulas](#) on page 480.

### 6.205.4. Tab 'Grids'

A tabular layout can be composed of one or multiple **grids**.

One same graphic can also be placed in more than one grid. For example one grid where its stations are not rotated and another grid where the stations are rotated 180 degrees.

#### Grid Columns

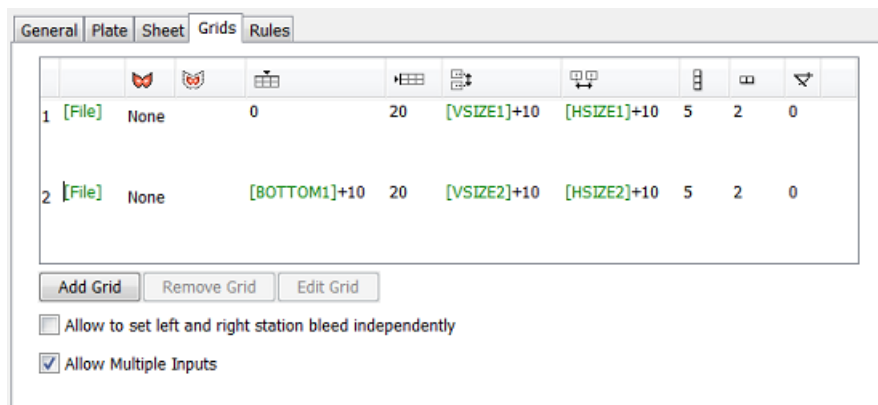











**Tip:** Right-click a table cell to discover several editing options.

The columns from left to right:

1. **Grid number:** Click the number to select the grid that you want to remove or edit.
2. **File Name:** The name of the one-up graphic repeated in this in this grid.
3. **Die Shape:** You here define a die shape around each one-up in that grid. This will mask out any objects outside that shape. Click the field to choose between **'None'** or **'Borders'** (Trim Box).



**Note:** 'None' also means that these graphics will be excluded from the [SmartFlapping process](#).

4.  **Bleed** : The value you type in here spreads the **Die Shape** with a bleed of this distance. The die shape is spread but die shapes will not overlap.
5.  **Vertical offset to the sheet** : To define the top or bottom shift of the grid in relation to the sheet, depending on the setup of the *Origin*.
6.  **Horizontal offset to the sheet** : To define the left or right shift of the grid in relation to the sheet, depending on the setup of the *Origin*.
7.  **Vertical step** : To define the vertical distance between two stations on this grid. The distance is calculated from the center point of the one-up to the center point of the next one-up.
8.  **Horizontal step** : To define the horizontal distance between two stations on this grid. The distance is calculated from the center point of the one-up to the center point of the next one-up.
9.  **Vertical count** : To define the number of times you want to repeat the one-up vertically.
10.  **Horizontal count** : To define the number of times you want to repeat the one-up horizontally.
11.  **Angle** : To define the angle to rotate the one-up clockwise in this grid.
12. **Head Turn / Stagger** : This column shows icons that illustrate the head turn or stagger that you defined for this grid (for example  or ). Learn more in [Grid Settings](#) on page 475.

### Managing Grids

- Click **Add Grid** to add an extra grid at the bottom of the list.



**Note:** When this ticket has multiple input files, it automatically adds enough grids to have one for each input file (the ticket is automatically updated). Also see the below option 'Allow Multiple Inputs'.

- To remove a grid, select it and click **Remove Grid**. There is no undo function.
- Select a grid and click **Edit Grid** to define advanced grid settings (staggering, head turns...). Learn more in [Grid Settings](#) on page 475.

### Other Options

- **Allow to set left and right station bleed independently**: When selected, 2 extra columns appear, one for left bleed, one for right bleed.



**Important:** Before selecting this option, first fill in a general **Bleed** (for which you first need to define the **Die Shape**).

- **Allow Multiple Inputs**



**Attention:** When you do not see this option in some older task-ticket, then open a task ticket from the [Tickets view](#), save it as a custom ticket and you will be able to use this option.

This option decides what the task should do when you launch it on multiple files.

- Select this option to generate one step & repeat file containing all of the input files. Each input file will be assigned to a different grid.  
When there are multiple input files, their grid will by default be placed in alphabetical order.
- Deselect this option to treat each input file separately. The task then generates a separate step & repeat file for each input file.



### Grid Settings

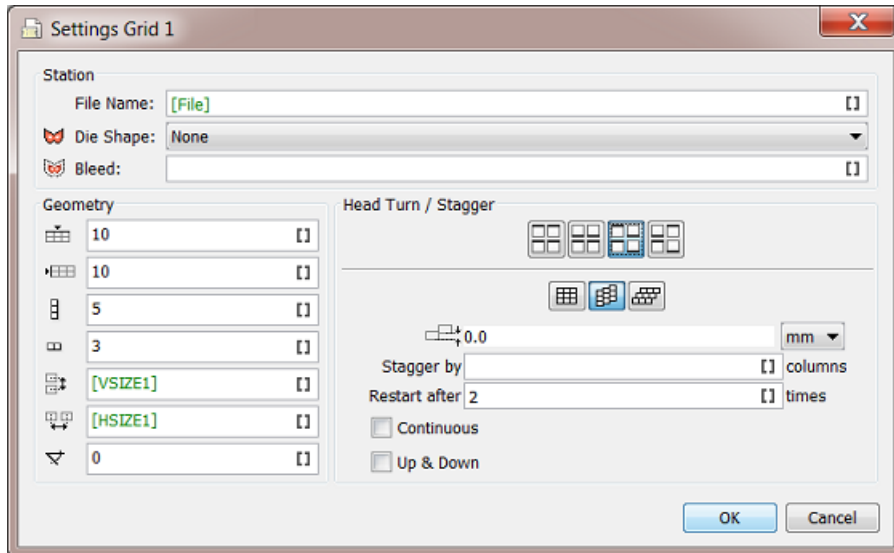

- **Station:** These options are the same as defined in the ticket's tab **Grids**. You can choose where to define them.
- **Geometry:** These options are the same as defined in the ticket's tab **Grids**. You can choose where to define them.
- **Head Turn / Stagger**
  - **Head Turn:** Choose if and how you want to rotate certain stations on this grid by 180 degrees.
    - Choose  (first button) to keep all stations as they are, without rotating them (default).



- Choose  (second button) to rotate stations in alternating rows by 180°.

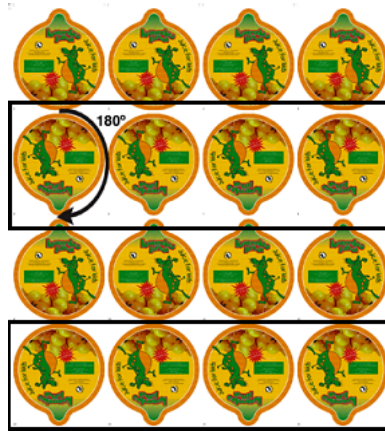

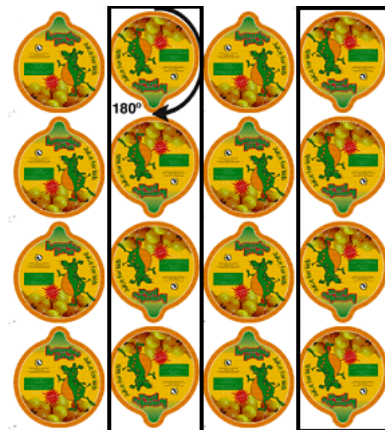

- Choose  (third button) to rotate stations in alternating columns by 180°.



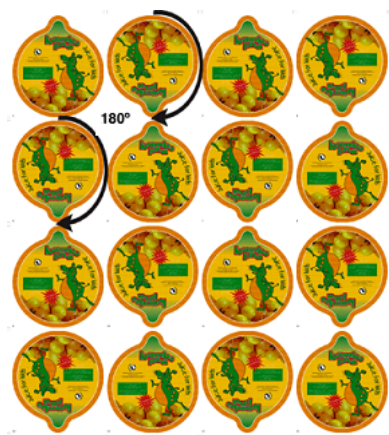

- Choose  (fourth button) to rotate stations both in alternating columns and in alternating rows by 180°.



- **Stagger:** Choose if and how you want to stagger (move) certain stations on this grid horizontally or vertically.
  - Choose  (first button) to keep all stations as they are, without staggering them (default).
  - Choose  (second button) to define a vertical stagger for this grid.
  - Choose  (third button) to define an horizontal stagger for this grid.

To define a horizontal or a vertical stagger:

1. Choose  or .
2. In , enter a stagger value. Choose a unit or define a percentage of the width or height of the station.

See this example of a 4 x 6 Step & Repeat with a 50% vertical stagger:



3. **Stagger by x Columns/Rows.** This value decides the amount of columns or rows after which the stagger occurs. In above examples, this was the default value of 1, so each column or row gets a different shift.
4. **Restart after x Columns:** You can choose to restart the staggering after a certain number of rows or columns. This means that:

- For vertical staggering: the top station of that column is positioned at the same height as the top station of the first column (it has the same vertical offset from the top of the sheet).

See this example where the staggering restarts after 3 columns:



- For horizontal staggering: the first (left most) station of that row is positioned at the same horizontal offset as the first station of the first row.
- Select **Continuous** if you want to add extra stations to fill the blank space.

The example below is a 4 x 6 Step & Repeat (with staggering restarting after 3 columns), but the **Continuous** option added some stations vertically:



**Note:** In the "Dynamic" variant of this task type, this option is named **Add Partial Labels**. Learn more about this task in [Step & Repeat Tabular](#) on page 483.

- Use **Up & Down** together with **Restart after** to go back in the other direction gradually instead of at once.

See this example where the staggering restarts after 3 columns, with the **Up & Down** option selected:



### 6.205.5. Tab 'Rules'

You can modify the task's end status by setting up one or multiple smart rules.

#### An Example

Follow these steps to add a rule that prevents the creation of step & repeat files with more than 6 inks:

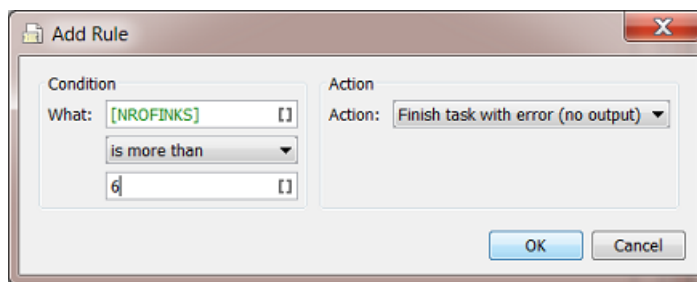

1. In the tab **Rules**, click **Add** to open the **Add Rule** dialog:
2. Define the **Condition**:
  - **What**: Enter the parameter you want to check (most probably a SmartName).
  - Choose an 'expression' from the list.
  - Enter a value for the parameter.
3. In **Action**, define what needs to happen when the **Condition** is met. Choose from:
  - The **task finishes with a warning**
  - The **task finishes with a warning (there's no output)**.
4. Click **OK** to confirm. The resulting rule shows up in the tab 'Rules':

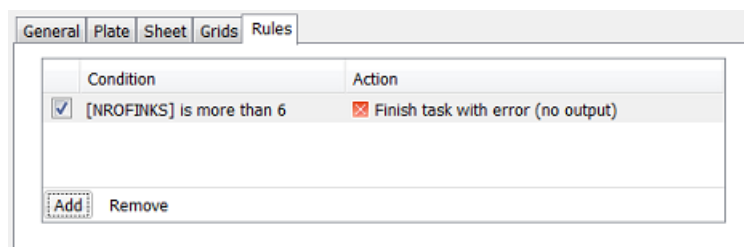

5. Add more rules if you want to. Their list will be checked from top to bottom.



**Tip:** You can choose to save tickets in which you switch off some rules and keep others active.

## 6.205.6. Using Formulas

### Example of a Grid defining an Automatic Fill

1. First we need to define an absolute size for sheet and plate:

Plate  
 Size:    
 Shrink:  %  %  
 Sheet  
 Size:    
 Offset:   Sheet Position on Plate:

2. Now you can enter these grid settings:

Grids		Rules							
File Name									
1 banana_y oghurt.pdf	Borders	3.0	$([VSHEET]/[VCOUNT1] - [VLABEL1])/2$	$([HSHEET]/[HCOUNT1] - [HLABEL1])/2$	$[VSHEET]/[VCOUNT1]$	$[HSHEET]/[HCOUNT1]$	$[VSHEET]/[VLABEL1]$	$[HSHEET]/[HLABEL1]$	

Clarification of the formulas:

- First you define the vertical (and horizontal ) count of the grid: The vertical count is the vertical size of the sheet divided by vertical size of the station:  $VSHEET / VLABEL1$ . For the horizontal count, use  $HSHEET / HLABEL1$ .
- Then you are able to define the vertical (and horizontal ) step: Vertical step is the vertical sheet size divided by the vertical count:  $VSHEET / VCOUNT1$ . For the horizontal step, use  $HSHEET / HCOUNT1$ .
- Now for the vertical (and horizontal ) offset: You want to center the step & repeat on the sheet. You can do that by defining the vertical offset as half the vertical step minus the vertical size of the station:  $(VSTEP1 - VLABEL1) / 2$ . For the horizontal offset, use  $(HSTEP1 - HLABEL1) / 2$ .

Some of the fields work with **formulas**, a special set of parameters unique to this task.

There are two kinds of formulas: **Global** formulas that define the whole step & repeat and **Grid** specific formulas that define individual grids.



**Note:** When a step & repeat contains two different graphics, there will be at least two grids. Each grid has its own number (see most left column).

**Global** formulas:

- **VPLATEFIT**: Vertical plate size that fits around a step & repeat sheet and SmartMarks.
- **HPLATEFIT**: Horizontal plate size that fits around a step & repeat sheet and SmartMarks.
- **VPLATE**: Vertical plate size.
- **HPLATE**: Horizontal plate size.
- **VSHEETOFFSET**: Vertical offset of the sheet relative to the Plate.
- **HSHEETOFFSET**: Horizontal offset of the sheet relative to the Plate.
- **VSHEETFIT**: Vertical sheet size that fits around the step & repeat.
- **HSHEETFIT**: Horizontal sheet size that fits around the step & repeat.
- **VSHEET**: Vertical sheet size.
- **HSHEET**: Horizontal sheet size.
- **SHEETTOP**: Top position of the sheet relative to the Plate.
- **SHEETLEFT**: Left position of the sheet relative to the Plate.
- **SHEETBOTTOM**: Bottom position of the sheet relative to the Plate.
- **SHEETRIGHT**: Right position of the sheet relative to the Plate.
- **NROFINKS**: Number of non-technical inks (Technical inks will not be printed).
- **NROFGRIDS**: Number of grids.

**Grid** specific formulas (x = the grid number):

- **VLABELx**: Vertical size of non-rotated station.
- **HLABELx**: Horizontal size of non-rotated station.
- **VSTEPx**: Vertical step size, from center point to center point.
- **HSTEPx**: Horizontal step size, from center point to center point.
- **VSIZEx**: Vertical size of bounding box of rotated station.
- **HSIZEx**: Horizontal size of bounding box of rotated station.
- **VCOUNTx**: Number of vertical step & repeats in grid x.
- **HCOUNTx**: Number of horizontal step & repeats in grid x.
- **ANGLE**: Angle of the rotation.
- **GRIDVSIZEx**: Vertical size of the grid (top-bottom).
- **GRIDHSIZEx**: Horizontal size of the grid (left-right).
- **TOPx**: Top position of the grid relative to the sheet.
- **LEFTx**: Left position of the grid relative to the sheet.
- **BOTTOMx**: Bottom position of the grid relative to the sheet.
- **RIGHTx**: Right position of the grid relative to the sheet.
- **BLEEDx**: Distance to spread the grid die shape with.

## 6.205.7. Using Database Queries: an Example

Many fields in this task can be defined by SmartNames. And SmartNames can get their values by doing SQL queries to non-Esko databases. This means that your tabular Step & Repeat ticket can automatically get (some of) its values directly from this external source ; no need for an Esko user to type them in again.

We use this simple example of a database describing your dies:

	Die	StepV	StepH	Teeth	Teethsize	DrumV	DrumH	Cilinder	GapH	GapV
▶ +	MES603	4	2	109	3.75	408.75	250	160.925196850	6	10
+	MES604	4	2	106	3.75	319.45482562	215	125.769616386	10	20
*		1	1			0		0	0	0

First we need to create these SmartNames, then we add them into the task ticket.

1. See this (old) example of how an SQL query SmartName is created to retrieve the value for vertical gap.



**Attention:** This page only summarizes how to do this. Learn more details in the chapter [SmartNames](#), specifically in the page on [Database Query SmartNames](#) on page 692.

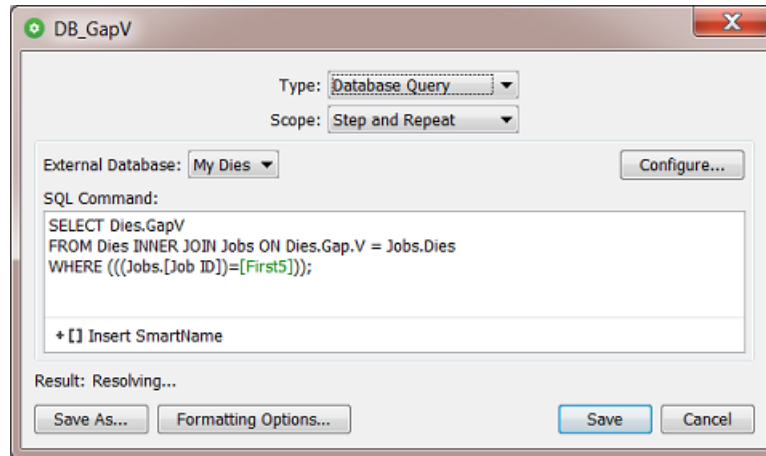

In this example, we created these SmartNames:

Customername	Global	Database Query
PhoneNumber	Global	Database Query
DB_DrumH	Step and Repeat	Database Query
DB_DrumV	Step and Repeat	Database Query
DB_teeth	Step and Repeat	Database Query
DB_gapH	Step and Repeat	Database Query
DB_gapV	Step and Repeat	Database Query
DB_StepH	Step and Repeat	Database Query
DB_StepV	Step and Repeat	Database Query

- DB\_DrumH: Retrieves the value for the horizontal size of the drum.
  - DB\_DrumV: Retrieves the value for the vertical size of the drum.
  - DB\_GapH: Retrieves the value of the gap's horizontal size.
  - DB\_GapV: Retrieves the value of the gap's vertical size.
  - DB\_Teeth: Retrieves the number of cylinder teeth.
  - DB\_StepH: Retrieves the value of the die's horizontal step.
  - DB\_StepV: Retrieves the value of the die's vertical step.
2. Now use those SmartNames in a ticket of the **Step & Repeat Tabular** task. Use the **Insert SmartNames...** button, or right-click, browse and select it.

The **General** tab can look like this:



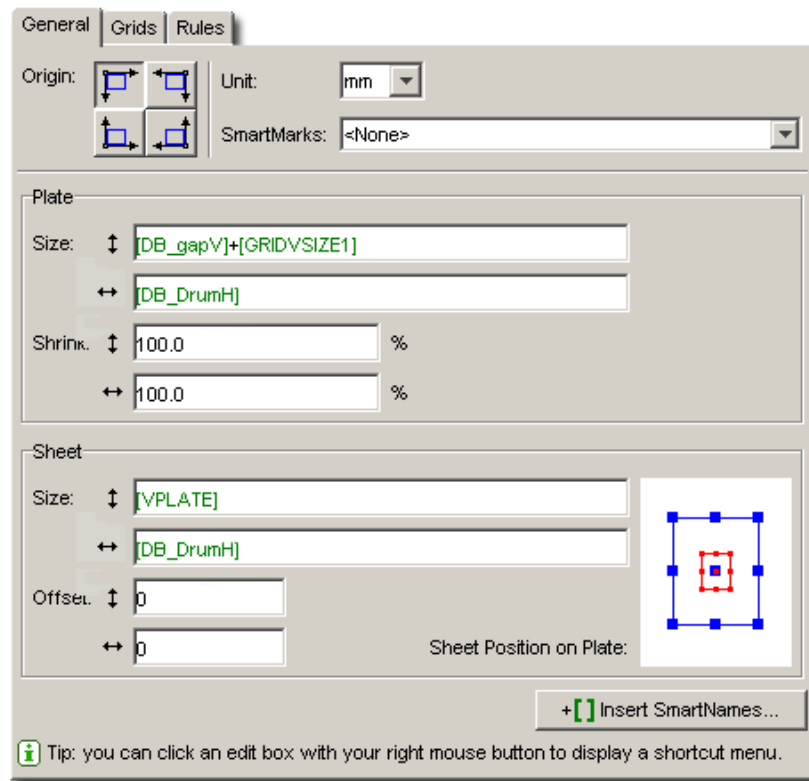

The **Grids** tab can look like this:

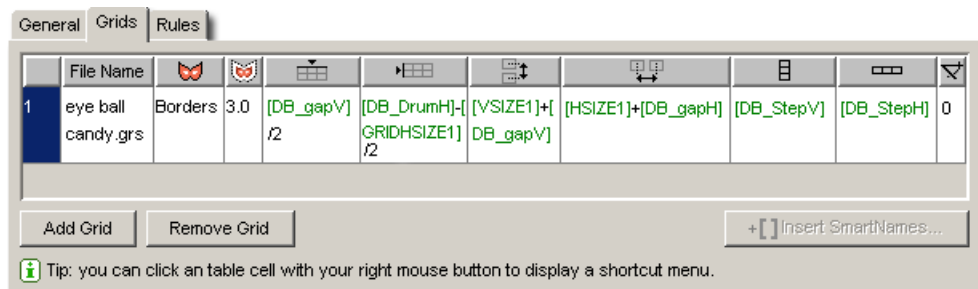

## 6.206. Step & Repeat Tabular

This **Step & Repeat Tabular** task allows you full control over the positioning of files, much like if you would do this in ArtPro+ or in [PowerLayout Standalone](#) (an Esko plug-in for Adobe Illustrator). It also uses the graphics engine of ArtPro+ ('NDL').



**Attention:** The marks you add to this layout need to be **'Dynamic'** marks. You can not add 'SmartMarks' here (older type of marks created in Esko's classic editors PackEdge or Plato).

Use this task when you do *not* use a template that was created in ArtPro+ or with PowerLayout Standalone. If you do want to use such a template, then use the task [Step & Repeat Template based](#) on page 500.

The task outputs a PDF+ file, i.e. native PDF file.



**Attention:** To avoid overwriting the (first) input file, make sure you define a specific name for the output file.

**Task Settings**

Selecting one of the items in this field displays their available settings in the field on the right. As usual, these settings can also be set by using **SmartNames**. Some fields also allow the use of [calculations and SmartName formulas](#).



**Note:** Also buttons or icons can be set by SmartNames. Learn more in [SmartNames of Parameter Values](#) on page 729.



**Note:** Most all of the settings in this ticket are identical to those in [PowerLayout Standalone](#).

- **Job:** Use the links to learn more about your options for the complete layout:

- **Optimize Output for VDP:**

This option is similar to the 'Optimize output' as used in the task [Add Dynamic Marks](#), but goes much further in changing the output file:

- It not only calculates the marks just once and then re-uses them (leaving all marks expanded, i.e. dead objects),
- in this step & repeat task it also expands the grids and removes all links to the one-ups.

The optimization is both in the speed of this task itself and in the size of the output file. This makes it most valid for the layout of VDP jobs.



This is an output optimization, so clearly something you will not do when you still want to modify the layout file in ArtPro+.

- **Automatically:** Depending on the content of the input file (whether it contains VDP type objects), the task decides whether to do this optimization or not.
- **No:** The task adds and evaluates the added marks on each page separately. The PDF+ marks also stay live objects: when you open the output in ArtPro+, you see the marks' properties and you can modify them. Also the grid objects will still be live grid objects.  
In older versions of this task, this option was called "Calculate for each page (more accurate)".
- **Yes:** The task calculates the marks only once and then copies them to all pages. Both the marks (all types) and grids are stored as dead objects.  
In older versions of this task, this option was called "Calculate once and copy (faster)".



**Note:** Selecting his option will make the task fail when the input file contains a Plate ID object (mark). This type of object may not be expanded before it was applied to a LENX file. Learn more in [Working with Plate ID](#) on page 1554.

- [Split Output \(incl. Blocks\)](#)

- [Sheet and Plate](#)
- [Filling Order](#)
- [Marks](#)
- [Grid specific Options](#)
- [Using Formula SmartNames and Calculations](#) on page 492
- [Specification of RunList XML in Step & Repeat tasks \(= excl. the Classic ones\)](#) on page 496
- **Grid selection:** Use   to **Add** or **Remove** grids.



**Note:** Grids are numbered sequentially. When there are 3 grids and you remove 'Grid 2', then 'Grid 3' will automatically be renamed to 'Grid 2'.

- **Preview:** The preview shows the position of all grids. The selected grid is highlighted in orange. Any others are displayed in blue.

### 6.206.1. Assignment of Input Files

How this task assigns the incoming files to a grid depends on the type of input:

- **A single PDF file with only a single page:** This triggers an automatic **Grid Filling**, i.e. every cell of the grid will be filled with the one-up input file.
- **A single PDF file with multiple pages:** The task creates only one grid with each page placed once, in a single cell, not repeated.



**Tip:** Use an XML input file to also repeat these pages. For example: a PDF has 3 pages, each page contains a design variant / flavor of the design. The XML can then specify that it needs 1.000 bananas (page 1), 500 apples (page 2), etc. Learn more below.

- **Multiple PDF files:** By default, the ticket automatically creates a grid for each PDF: the 1st input file will be placed in the first grid, etc.



**Tip:** Use the '[Sort](#)' workflow control to change this sequence of input files as they enter this task.



**Attention:** There is an exception that is valid in a dynamic VDP workflow (where each input file only needs to be output once): When the input files follow the naming convention `<SameFileName-Number>`, they will be grouped together in a same grid.

For example, `banana-001.pdf`, `banana-002.pdf`, `banana-003.pdf` will be placed in a same grid.

- **An XML file for each grid.** Learn more in the dedicated page [Specification of RunList XML in Step & Repeat tasks \(= excl. the Classic ones\)](#) on page 496.

### 6.206.2. Splitting Output, Blocks and Gaps

To limit the size of the output PDF file, this task also uses the technique of "PDF forms": Each input PDF file is only embedded once into the output file.

When used in a VDP context, where each station can contain a different graphic, this size can become huge and easily reach the computer's processing power limit. Tasks handling such files require a lot of system memory and read/write operations, and this impacts the processing speed. Some RIPs also have problems processing huge PDFs.

This is why you can choose to split this output. The task then creates a set of smaller PDFs instead of a single large one.

Choose how you want to split the output file:

- **No (Single File).**
- **Automatically.** The task then calculates the number of sheets per file so that the output file sizes stay within reasonable limits.
- **On Number of Sheets.** This way, each output file except the first and last one contains the **Number of Sheets** (pages) specified.
- **On Block Size of Grid 1** (only valid for output to digital presses):



**Note:** Learn about the concept of Blocks and Gaps below.

A block with an optional gap must fit completely on sheets. This can be expressed by a formula:  $(\text{block\_rows} + \text{gap\_rows}) \bmod \text{grid\_rows} = 0$ . The task will fail when this is not the case for the first grid.



**Note:** In formulas, 'mod' stands for the 'modulo' operation: the remainder (leftover) after division. For example "9 mod 3" results in 0, but "5 mod 2" results in 1. Learn more about 'mod' on [this wiki page](#).

Use this mode when there is only one grid or if that condition is met for all grids. This feature assumes that if the user took care to enter specific values for rows and gaps, that he then likely will want to use those same numbers for splitting.

When defining this choice via SmartNames, the resulting value must match one of these: **OFF, AUTO, SHEETS, BLOCK.**

### Blocks and Gaps: Concept and Examples



**Note:** Some example use cases:

- You need to print 10.000 labels and deliver them on reels of 500 labels. You then define a block of 500 and add a gap between those blocks (empty one-ups).
- You want those gaps to cover the complete circumference of the reel, to cover the labels underneath and so protect them from any damage. In case of VDP each label might even be unique.

Blocks are used to split jobs into fixed length segments and to control the filling order. They are defined per grid. Each grid can have different block settings:

- **Block Length** is a number of rows.
- **Gap Length** is a number of rows ("zero" = no gap).
- **Grid Height** is the number of rows in a grid.

A gap works as a separator. It is represented by one or more empty rows inserted between two blocks.

- If  $\text{block length} + \text{gap length} = \text{grid height}$ , then a gap will appear on each sheet on the same place.
- If  $\text{block length} + \text{gap length} \bmod \text{grid height} > 0$ , then the gap will be floating ; it will appear on different positions.
- If  $\text{block length} + \text{gap length} > \text{grid height}$  *and*  $\text{block length} + \text{gap length} \bmod \text{grid height} = 0$ , then a gap will appear on the same position on the sheet but not on each sheet.

Here are 3 examples of the above mentioned 3 cases:

<p><b>block = 5</b> <b>gap = 1</b> <b>grid = 6</b></p> <table border="1" style="border-collapse: collapse; width: 60px; height: 60px; text-align: center;"> <tr><td>X</td><td>X</td><td>X</td></tr> <tr><td>X</td><td>X</td><td>X</td></tr> <tr><td>X</td><td>X</td><td>X</td></tr> <tr><td>X</td><td>X</td><td>X</td></tr> <tr><td>X</td><td>X</td><td>X</td></tr> <tr><td>=</td><td>=</td><td>=</td></tr> </table> <table border="1" style="border-collapse: collapse; width: 60px; height: 60px; text-align: center;"> <tr><td>X</td><td>X</td><td>X</td></tr> <tr><td>X</td><td>X</td><td>X</td></tr> <tr><td>X</td><td>X</td><td>X</td></tr> <tr><td>X</td><td>X</td><td>X</td></tr> <tr><td>X</td><td>X</td><td>X</td></tr> <tr><td>=</td><td>=</td><td>=</td></tr> </table> <table border="1" style="border-collapse: collapse; width: 60px; height: 60px; text-align: center;"> <tr><td>X</td><td>X</td><td>X</td></tr> <tr><td>X</td><td>X</td><td>X</td></tr> <tr><td>X</td><td>X</td><td>X</td></tr> <tr><td>X</td><td>X</td><td>X</td></tr> <tr><td>X</td><td>X</td><td>X</td></tr> <tr><td>=</td><td>=</td><td>=</td></tr> </table>	X	X	X	X	X	X	X	X	X	X	X	X	X	X	X	=	=	=	X	X	X	X	X	X	X	X	X	X	X	X	X	X	X	=	=	=	X	X	X	X	X	X	X	X	X	X	X	X	X	X	X	=	=	=	<p><b>block = 3</b> <b>gap = 1</b> <b>grid = 6</b></p> <table border="1" style="border-collapse: collapse; width: 60px; height: 60px; text-align: center;"> <tr><td>X</td><td>X</td><td>X</td></tr> <tr><td>X</td><td>X</td><td>X</td></tr> <tr><td>X</td><td>X</td><td>X</td></tr> <tr><td>=</td><td>=</td><td>=</td></tr> <tr><td>X</td><td>X</td><td>X</td></tr> <tr><td>X</td><td>X</td><td>X</td></tr> </table> <table border="1" style="border-collapse: collapse; width: 60px; height: 60px; text-align: center;"> <tr><td>X</td><td>X</td><td>X</td></tr> <tr><td>=</td><td>=</td><td>=</td></tr> <tr><td>X</td><td>X</td><td>X</td></tr> <tr><td>X</td><td>X</td><td>X</td></tr> <tr><td>X</td><td>X</td><td>X</td></tr> <tr><td>=</td><td>=</td><td>=</td></tr> </table> <table border="1" style="border-collapse: collapse; width: 60px; height: 60px; text-align: center;"> <tr><td>X</td><td>X</td><td>X</td></tr> <tr><td>X</td><td>X</td><td>X</td></tr> <tr><td>X</td><td>X</td><td>X</td></tr> <tr><td>=</td><td>=</td><td>=</td></tr> <tr><td>X</td><td>X</td><td>X</td></tr> <tr><td>X</td><td>X</td><td>X</td></tr> </table>	X	X	X	X	X	X	X	X	X	=	=	=	X	X	X	X	X	X	X	X	X	=	=	=	X	X	X	X	X	X	X	X	X	=	=	=	X	X	X	X	X	X	X	X	X	=	=	=	X	X	X	X	X	X	<p><b>block = 11</b> <b>gap = 1</b> <b>grid = 6</b></p> <table border="1" style="border-collapse: collapse; width: 60px; height: 60px; text-align: center;"> <tr><td>X</td><td>X</td><td>X</td></tr> <tr><td>X</td><td>X</td><td>X</td></tr> <tr><td>X</td><td>X</td><td>X</td></tr> <tr><td>X</td><td>X</td><td>X</td></tr> <tr><td>X</td><td>X</td><td>X</td></tr> <tr><td>X</td><td>X</td><td>X</td></tr> </table> <table border="1" style="border-collapse: collapse; width: 60px; height: 60px; text-align: center;"> <tr><td>X</td><td>X</td><td>X</td></tr> <tr><td>X</td><td>X</td><td>X</td></tr> <tr><td>X</td><td>X</td><td>X</td></tr> <tr><td>X</td><td>X</td><td>X</td></tr> <tr><td>X</td><td>X</td><td>X</td></tr> <tr><td>=</td><td>=</td><td>=</td></tr> </table> <table border="1" style="border-collapse: collapse; width: 60px; height: 60px; text-align: center;"> <tr><td>X</td><td>X</td><td>X</td></tr> <tr><td>X</td><td>X</td><td>X</td></tr> <tr><td>X</td><td>X</td><td>X</td></tr> <tr><td>X</td><td>X</td><td>X</td></tr> <tr><td>X</td><td>X</td><td>X</td></tr> <tr><td>X</td><td>X</td><td>X</td></tr> </table> <table border="1" style="border-collapse: collapse; width: 60px; height: 60px; text-align: center;"> <tr><td>X</td><td>X</td><td>X</td></tr> <tr><td>X</td><td>X</td><td>X</td></tr> <tr><td>X</td><td>X</td><td>X</td></tr> <tr><td>X</td><td>X</td><td>X</td></tr> <tr><td>X</td><td>X</td><td>X</td></tr> <tr><td>=</td><td>=</td><td>=</td></tr> </table>	X	X	X	X	X	X	X	X	X	X	X	X	X	X	X	X	X	X	X	X	X	X	X	X	X	X	X	X	X	X	X	X	X	=	=	=	X	X	X	X	X	X	X	X	X	X	X	X	X	X	X	X	X	X	X	X	X	X	X	X	X	X	X	X	X	X	X	X	X	=	=	=
X	X	X																																																																																																																																																																																				
X	X	X																																																																																																																																																																																				
X	X	X																																																																																																																																																																																				
X	X	X																																																																																																																																																																																				
X	X	X																																																																																																																																																																																				
=	=	=																																																																																																																																																																																				
X	X	X																																																																																																																																																																																				
X	X	X																																																																																																																																																																																				
X	X	X																																																																																																																																																																																				
X	X	X																																																																																																																																																																																				
X	X	X																																																																																																																																																																																				
=	=	=																																																																																																																																																																																				
X	X	X																																																																																																																																																																																				
X	X	X																																																																																																																																																																																				
X	X	X																																																																																																																																																																																				
X	X	X																																																																																																																																																																																				
X	X	X																																																																																																																																																																																				
=	=	=																																																																																																																																																																																				
X	X	X																																																																																																																																																																																				
X	X	X																																																																																																																																																																																				
X	X	X																																																																																																																																																																																				
=	=	=																																																																																																																																																																																				
X	X	X																																																																																																																																																																																				
X	X	X																																																																																																																																																																																				
X	X	X																																																																																																																																																																																				
=	=	=																																																																																																																																																																																				
X	X	X																																																																																																																																																																																				
X	X	X																																																																																																																																																																																				
X	X	X																																																																																																																																																																																				
=	=	=																																																																																																																																																																																				
X	X	X																																																																																																																																																																																				
X	X	X																																																																																																																																																																																				
X	X	X																																																																																																																																																																																				
=	=	=																																																																																																																																																																																				
X	X	X																																																																																																																																																																																				
X	X	X																																																																																																																																																																																				
X	X	X																																																																																																																																																																																				
X	X	X																																																																																																																																																																																				
X	X	X																																																																																																																																																																																				
X	X	X																																																																																																																																																																																				
X	X	X																																																																																																																																																																																				
X	X	X																																																																																																																																																																																				
X	X	X																																																																																																																																																																																				
X	X	X																																																																																																																																																																																				
X	X	X																																																																																																																																																																																				
X	X	X																																																																																																																																																																																				
X	X	X																																																																																																																																																																																				
=	=	=																																																																																																																																																																																				
X	X	X																																																																																																																																																																																				
X	X	X																																																																																																																																																																																				
X	X	X																																																																																																																																																																																				
X	X	X																																																																																																																																																																																				
X	X	X																																																																																																																																																																																				
X	X	X																																																																																																																																																																																				
X	X	X																																																																																																																																																																																				
X	X	X																																																																																																																																																																																				
X	X	X																																																																																																																																																																																				
X	X	X																																																																																																																																																																																				
X	X	X																																																																																																																																																																																				
=	=	=																																																																																																																																																																																				

### 6.206.3. Sheet and Plate Settings

The **Sheet Size** is the area where your one-up grids will be positioned within the **Plate**.

You can define:

- **Plate Size:** Define its horizontal and vertical size.



**Note:** The plate size will correspond to the Media Box of the generated step & repeat PDF.



**Attention:** Take the printer's size limits into account when defining these values.

- **Distortion:** Set a horizontal and/or vertical value. The value '100%' equals no distortion. This value (formerly known as 'shrink') is used to compensate for plate distortion, later in the output process. Learn more about this [here](#).

- **Apply Distortion:** When should it be applied?

- **Later:** The task makes no changes to the file's page boxes but only adds the requested value in the output file's meta data. When you open that file in ArtPro+ you can see it mentioned in the document setup dialog. You can still change these values.
- **Immediately:** The requested distortion is executed on the file's page boxes and objects. Also the marks and grids are expanded. This is advised when sending to the output PDF to 3rd party devices.

When using a SmartName to decide this choice, its value should resolve to `immediately`; any other value will select `Later`.

- **Sheet Size:** This is the printable area on your plate.



**Note:** The sheet size will correspond to the Trim Box of the generated step & repeat PDF.

- **Position on Plate:** The blue square in the image represents the position of the sheet on the plate. You can click or drag this blue square to match the desired alignment.



- **Offset:** Use this to fine-tune the position. The values are calculated versus the light gray lines.

## 6.206.4. Filling Order



**Note:** We here refer to the one-up print items as 'items'.







These **Filling Order** options define how the items should be distributed over the grid. You can specify:

- a starting point
- whether the grid should be filled by row or by column
- gaps (empty stations on the grid).

Options:

- **Scope Settings:**

- **Same Settings for all Grids:** This applies all the settings in this tab to each grid in the layout. This automatically disables setting a filling order on grid level.

- **Individual Settings for Each Grid:** Select this to set the (different) filling order on grid level.
- **Start Content Filling:** Choose where the first print item is printed (the next options then decide how the other items will follow):
  - : Top left. When using a *Parameter Value SmartName*, its value should be `TL`.
  - : Top right. When using a *Parameter Value SmartName*, its value should be `TR`.
  - : Bottom left. When using a *Parameter Value SmartName*, its value should be `BL`.
  - : Bottom right. When using a *Parameter Value SmartName*, its value should be `BR`.
  - Also specify whether the grid is to be filled by row  (SmartName value `rows`) or by column  (SmartName value `columns`).

See the preview of your selected options on the right hand side.

- The **Printing direction** marked with an arrow indicates the direction that the paper/substrate flows through the press.
- In that preview, a black dot shows the first record.
- Some examples:
  - The distribution starts on top left, with vertical flow:



- The distribution starts top right, with vertical flow:



- The distribution starts top left, with horizontal flow:

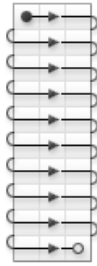

- **Fill over:** Choose if you want to distribute the items over the **Complete Job** or over **Blocks**. Learn about the concept of blocks [here](#).
- If you choose **Blocks**, the flow of variable data (the one-up variants) will run over blocks of a specified size, then run over the next block when the previous one is complete.

The preview also shows the blocks:



**Block Size:** You can define their size as the complete '**Job**' or an amount of **Sheets** or **Rows**.

- When, in '**Fill over**', you selected '**Complete Job**', then the **Block Size** will be 1 **Job** by default. You can set it to another unit if you still want to print in blocks, but without having the flow of (variable data) items respect the block. This is useful if you want to add gaps (see below).



- **Gap between Blocks:** This option is available if you have chosen to **Fill over Blocks**, or to fill over the **Complete Job** but still have blocks (as explained above).

This option adds white space in between the blocks.



**Gap Size:** Define the size of this gap.

### 6.206.5. Adding Marks

Use this tab to add **Dynamic Marks** to your layout.

Learn more about Dynamic Marks in the description of the task [Add Dynamic Marks](#) on page 249.

### 6.206.6. Specific Grid Options

- Specify the **Cell Width** and **Cell Height** for the one-up item ("cell").
- Set the grid **Orientation** and **Clip Bleed**.



defines the initial **Orientation** of the one-ups in this grid. Their orientation within the layout can be changed further by the option **Head Turn**.

- **Repeat**  
Define how many times you want to repeat the one-up (V & H) and define the gap between these repeats (V & H).
- If wanted, specify a **Head Turn** and /or **Stagger**.  
Learn more about these options [here](#).
- **Clip Bleed**  
Learn about bleed in the [user guide of ArtPro+](#).



**Note:** Deselecting 'Clip Bleed' can cause one-ups to overlap. This can be useful in some special layouts.



**Note:** Learn more about what happens when bleed from panels overlaps in [Bleed and overlap](#) on page 296 and in [Bleed Overlap Priority decided by ArtiosCAD Artwork Panels](#) on page 297.

**Keep Outer Bleed:**

Select the appropriate icon of what should happen to bleed on the outer sides of the layout.

- Keep all (default)
- Keep horizontal outer bleed only
- Keep vertical outer bleed only

**Bleed Overlaps:**

When two one-ups (or their bleed) overlap (i.e. if the size of the Die Shape + the "Clip Bleed at" distance is larger than the step distance), use this tool to define how the bleed in between the one-ups should be calculated.

- Select the appropriate icon if you want a bleed overlap and if so which type.
- **Clip Overlaps:** When choosing a type of overlap, you can define a distance where the overlap should be clipped.

Learn more in the [user guide of ArtPro+](#).

- Specify the **Position** of this grid using the positioning tool and **Offset** distances.

Define the positioning reference for this grid: **Attach to the Sheet** or the **Plate** area.

In below example, the top center of the (bounding box of the) layout will be placed on the left bottom corner of the (bounding box of the) reference (that you defined in 'Attach to').



In '**Offset**', you can still move the layout based on the above defined position. The direction of the offset (up, down, left or right) depends on the positioning, and is indicated by the arrows.

**6.206.7. Using Formula SmartNames and Calculations**

Apart from entering values or using SmartNames, most of the [Sheet and Plate](#) and [Grid](#) settings also allow entering calculation expressions and formula SmartNames.

**Calculations**

Calculation expressions can contain:

- Numeric values with units: 1mm, 2in, 3pt, ... (the default unit for size is mm).
- Numeric values without units will be converted to the default unit for that parameter: For example: 2cm\*5 => 100mm. And 2cm+5 => 25mm

- Arithmetic operators to add-subtract-multiply-divide: +, -, \*, /
- Round parentheses to indicate grouping of operations: ( )

Numeric values use both '.' and ',' as a decimal separator.

An example: In a field that defines a size, we use SmartName [ A ] with value 12 and SmartName [ B ] with value 34 and both are also used in the formula  $\langle A \rangle \langle B \rangle + 5 \text{cm}$ . The task first calculates the SmartNames into text, resulting in  $1234 + 5 \text{cm}$ . Then it converts the used units and performs calculations, resulting in the field's value 1284 (in millimeters).

### Formula SmartNames - Global - category "Step and Repeat"

This task offers extra SmartNames that are specific for a tabular way of making a layout.

Right-click in a field, choose **Insert SmartName**, choose the category and then select the formula SmartName.

Name	Input Field	Variable	Description
<b>Plate Width</b>	Sheet and Plate / Plate Size	HPLATE	Horizontal plate size
<b>Plate Height</b>	Sheet and Plate / Plate Size	VPLATE	Vertical plate size
<b>Sheet Width</b>	Sheet and Plate / Sheet Size	HSHEET	Horizontal sheet size
<b>Sheet Height</b>	Sheet and Plate / Sheet Size	VSHEET	Vertical sheet size
<b>Horizontal Sheet Offset</b>	Sheet and Plate / Offset	HSHEETOFFSET	Horizontal sheet offset from the selected position on the plate
<b>Vertical Sheet Offset</b>	Sheet and Plate / Offset	VSHEETOFFSET	Vertical sheet offset from the selected position on the plate
<b>Number of Grids</b>	(Add/Remove grid buttons)	NROFGRIDS	Number of grids
<b>Sheet Top</b>	-	SHEETTOP	Top position of the sheet on the plate (from top-left corner of plate) <sup>1</sup>
<b>Sheet Left</b>	-	SHEETLEFT	Left position of the sheet on the plate (from top-left corner of plate) <sup>1</sup>
<b>Sheet Bottom</b>	-	SHEETBOTTOM	Bottom position of the sheet on the plate (from top-left corner of plate) <sup>1</sup>
<b>Sheet Right</b>	-	SHEETRIGHT	Right position of the sheet on the plate (from top-left corner of plate) <sup>1</sup>
<b>Horizontal Sheet Fit</b>	-	HSHEETFIT	Horizontal size of the bounding box of all grid objects <sup>2</sup>
<b>Vertical Sheet Fit</b>	-	VSHEETFIT	Vertical size of the bounding box of all grid objects <sup>2</sup>



**Note:**

- **(1)** : The Sheet position calculation is using the selector for sheet "Offset" and the "Position on Plate" buttons. If the sheet is positioned to the center or the right side of the plate, the calculation also depends on the Plate Size.
- **(2)** : Sheet Fit variables can be used to automatically fit the sheet around all grids. These Sheet Fit variables can only be calculated once that all grid positions were resolved.

There are some limitations to how the grid position can be specified to allow Sheet Fit calculation.

- When Sheet Fit variables are **not used**, grids can be attached to (or positioned according to) another grid without any limitations. All attachment points can be used and the offset can be specified.
- When Sheet Fit variables are **used**, to avoid circular dependencies, it is not possible to attach a grid to the plate, but the sheet must be used instead. Moreover, the top-left corner of the grid must always be attached to the top-left corner of the sheet. You can also still specify offset variables.

An extra note on combining Sheet Fit variables with Offset variables:

- Only the right and bottom sides of grids are used for Sheet Fit calculation. The left and top sides are ignored to make sure that the offset of grids attached to the sheet is taken into account. In other words, parts of the grid layout crossing the left and top borders of the sheet are ignored. Sheet Fit is calculated so that the right-most and the bottom-most edge of the grid layout are inside a rectangle starting at the sheet top-left corner and with width and height defined by the results of Horizontal and Vertical Sheet Fit.

A simple example: A grid has a width of 100 mm and is attached by its top-left corner to the top-left of the sheet. When there is no offset, Horizontal Sheet Fit will result in 100 mm. When 10 mm offset is used, the result will be 110 mm. When -10mm offset is used, the result will be 90 mm.

**Formula SmartNames - Grid - category "Step and Repeat Grid x"**

Name	Input Field	Variable	Description
<b>Grid X One-up Width</b>	-	HLABELx	Horizontal size of the input one-up file
<b>Grid X One-up Height</b>	-	VLABELx	Vertical size of the input one-up file
<b>Grid X Non-rotated Cell Width</b>	Grid X / Cell Width	HCELLx	Horizontal size of the non-rotated cell
<b>Grid X Non-rotated Cell Height</b>	Grid X / Cell Width	VCELLx	Vertical size of the non-rotated cell
<b>Grid X Cell Orientation</b>	Grid X / Orientation	ANGLEx	Orientation of the grid cell (0 / 90 / 180 / 270 degrees clockwise)
<b>Grid X Cell Width</b>	-	HSIZEx	Horizontal size of the rotated cell
<b>Grid X Cell Height</b>	-	VSIZEx	Vertical size of the rotated cell

Name	Input Field	Variable	Description
<b>Grid X Column Count</b>	Grid X / Repeat / Columns	HCOUNTx	Number of horizontal cell repetitions in the grid
<b>Grid X Row Count</b>	Grid X / Repeat / Rows	VCOUNTx	Number of vertical cell repetitions in the grid
<b>Grid X Horizontal Gap Size</b>	Grid X / Repeat / H.Gap	HGAPx	Horizontal gap between the cell repetitions
<b>Grid X Vertical Gap Size</b>	Grid X / Repeat / V.Gap	VGAPx	Vertical gap between the cell repetitions
<b>Grid X Horizontal Step Size</b>	-	HSTEPx	Horizontal distance between the center points of the cell repetitions
<b>Grid X Vertical Step Size</b>	-	VSTEPx	Vertical distance between the center points of the cell repetitions
<b>Grid X Bleed</b>	Grid X / Clip at	BLEEDx	Distance at which the one-up bleed will be clipped
<b>Grid X Horizontal Offset</b>	Grid X / Offset	HGRIDOFFSETx	Horizontal grid offset from the selected position
<b>Grid X Vertical Offset</b>	Grid X / Offset	VGRIDOFFSETx	Vertical grid offset from the selected position
<b>Grid X Width</b>	-	HGRIDSIZEx	Horizontal grid size <sup>1</sup>
<b>Grid X Height</b>	-	VGRIDSIZEx	Vertical grid size <sup>1</sup>
<b>Grid X Top</b>	-	GRIDTOPx	Top position of the grid on the plate <sup>2</sup>
<b>Grid X Left</b>	-	GRIDLEFTx	Left position of the grid on the plate <sup>2</sup>
<b>Grid X Bottom</b>	-	GRIDBOTTOMx	Bottom position of the grid on the plate <sup>2</sup>
<b>Grid X Right</b>	-	GRIDRIGHTx	Right position of the grid on the plate <sup>2</sup>



**Note:**

- **(1)** : Stagger parameters are included in grid size calculations.
- **(2)** : Grid position calculation is based on the grid "Offset", the 9:9 "Position" selector and the "Attach to" reference object. If the grid is positioned to the center or the right side of the reference object, the calculation then also depends on size of the reference object.



**Note:** Due to technical limitations "Step and Repeat Grid X" category names are only translated for up to 10 grids. Grid variable categories for further grids will appear untranslated. This limitation does not affect calculations with variables from such categories.

## 6.206.8. Specification of RunList XML in Step & Repeat tasks (= excl. the Classic ones)

The **Step & Repeat** tasks can use XML files to specify their input files (one-ups) and how they should be placed on the layout. Such files typically come from external systems where production planning was decided. This page describes the format that such a "RunList" XML file needs to have.



**Note:** RunList elements used in a JDF file (so not just the generic XML file we describe here) are different. Such a JDF input file is only supported by the template based Step&Repeat task. Learn more in [Using JDF as Input File](#) on page 504.

### Structure

The XML file may contain only an XML header and a single root element **RunList**. UTF-8 coding is needed to support non-ASCII characters in file paths.



**Note:** While XML-files support UTF-8 encoding, all file names must follow the URL-encoding. This means that all characters other than basic ASCII letters and numbers (A-Z, a-z, 0-9) and a few punctuation marks ('-', '\_', '.', and '~'), must be percent-encoded (for example a space is noted as "%20"). Learn more about percent encoding in <http://en.wikipedia.org/wiki/Percent-encoding>.

### <RunList>

The **RunList** element can be used only at the root level and the current file format supports only one **RunList** element per file.

This element is used as a container that holds together one or more nodes of **RunListItem** (which describe one-ups for a specific grid).

It also contains an attribute **Version**, specifying the version of the **RunList** format. At this moment only version 1.0 is supported.



**Attention:** Each grid in the Step & Repeat must have an own **RunList** item and because only one is allowed per file, this means that each grid must have its own XML file.

### <RunListItem>

This element is used to contain a reference to the one-up file. It contains following mandatory elements:

**Table: RunListItem for Step & Repeat tasks (not the 'classic' ones)**

Element	Format	Description
<b>FileName</b>	URL	File specification of one-up file. It must be a valid URL (absolute path). Note: Special characters must be properly coded (see common XML rules).

Element	Format	Description
<b>FirstPage</b>	integer	Index of the first physical page from the used page range. The first page in PDF has index 1.
<b>LastPage</b>	integer	Index of the last physical page. Also this index starts from 1. Example: Page range 1..1 means single page with index 1. Page range 1..2 means pages 1 and 2.
<b>Repeats</b>	integer	<p>Number of page range repetitions (value must be greater than 0). Note: Page range 1..3 is repeated in this way: 1, 2, 3, 1, 2, 3, 1, 2, 3,...</p> <p>Under these conditions a reserved value -1 is allowed:</p> <ul style="list-style-type: none"> <li>• Only one RunListItem in RunList</li> <li>• FirstPage must be same as LastPage.</li> </ul> <p>In this case the task will calculate the number of repeats automatically to fill the complete grid.</p> <div style="border: 1px solid black; padding: 5px; margin-top: 10px;">  <b>Note:</b> Note: This feature is intended for 'static' jobs (not Variable Data jobs).         </div>

### Example

This example shows a RunList with two one-ups to be used in a grid:

- The first one-up is presented by a range of three pages (1 – 3) from the file A . pdf and needs to be repeated two times.
- The second one-up is presented by a single page (1) from file B . pdf and needs to be repeated five times.

The final order of pages used as one-ups will be: A1, A2, A3, A1, A2, A3, B1, B1, B1, B1, B1

```
<?xml version="1.0" encoding="UTF-8" ?>
<RunList version="1.0">
  <RunListItem>
    <FileName>file://server/JobContainer/Item1/A.pdf</FileName>
    <FirstPage>1</FirstPage>
    <LastPage>3</LastPage>
    <Repeats>2</Repeats>
  </RunListItem>
  <RunListItem>
    <FileName>file://server/JobContainer/Item1/B.pdf</FileName>
    <FirstPage>1</FirstPage>
    <LastPage>1</LastPage>
    <Repeats>5</Repeats>
  </RunListItem>
</RunList>
```

### Grid Filling with an XML RunList

If the task input file consists of a single XML file,

- with only one <RunListItem> ,
- where both the <FirstPage> and the <LastPage> are the same,
- and where the number of repeats is set to "-1",

then a special behavior is triggered, called **Grid Filling**. This means that every cell of the grid will be filled with the specified static one-up.

## 6.207. Step & Repeat Template based (Classic)

### Concept

This task creates a step & repeat file based on an template layout that was made earlier. This mode makes it useful for all packaging print segments: labels, boxes, flexibles, etc. It is typically used to make an identical layout but now for variant graphics with a same size as those placed in the template.



**Note:** About the name of the output Step & Repeat file:

- When no name is specified, the output file name will be the name of the first task input file. SmartNames based on this output file name will also follow that rule.
- When you choose the **Output Format** "PDF" and not "PDFPLA" (learn more below), the system will avoid that you ever overwrite your input file PDF name ; it will, in the output file name, automatically attach a suffix *\*\_rep\** to the name of your first input file.
- When you type in a specific output file name yourself, it will be honored, even when it then overwrites a file.

### Tab 'General'

#### • Output Format

- **PDFPLA:** In this format, the placed stations are referenced files, they are not embedded into the layout file. This keeps the layout file small but limits its use to applications that support such external references: Esko editors, Esko RIPs or any next workflows steps in Automation Engine that make use of this smart referencing.



**Attention:** If the input file of this task was a native PDF, this output mode will make the task end in error because a "PDFPLA can only contain references to normalized PDF".

- **Normalized PDF (embed all):** In this format, because all data is embedded, the PDF can be used to exchange this layout file to remote sites that also use tools that read this Esko Normalized data. For example: off-site printers that also use an Esko RIP.

This file format is larger in Mb, however it is important to know that the technique of "PDF forms" is used: each station is only embedded once into the output file. For example if it contains 5 banana labels and 5 lemon labels, the size of the PDF will only be slightly larger than the size of 1 banana PDF plus 1 lemon PDF file.

- **PDF:** This native PDF will have all data embedded and will also use "PDF forms" to optimize its size (as explained here above). Choose this output type PDF when you need to send this data to a non-Esko environment or device.



**Attention:** This output is only advised when the task input file is one or more native PDF(s). The advantage is then that there is no 'on the fly' normalization done on these native PDF stations ; they are untouched and are only placed into the native layout PDF.



This PDF has in its XMP also a description of the contents of its grids, their station names and amounts. Any distortion factor (here named "Shrink") will be calculated/executed in the PDF.



**Note:** Choosing this output type disables the options 'Screen Registration' and 'Include CAD info for Digital Flexo Suite'.

- You can add **SmartMarks**.



**Attention:** If you use a template that contains macros from the old Esko application QuickStep, these macros will be lost. You need to replace these macros with SmartMarks.

### Tab 'Stations'

You here decide which files will replace the template stations in the output file.

Before you can define the new station in this ticket, you first need to select an input file before opening the ticket. Then select the template (click the browse button and select it).

The ticket reads the template and lists the stations it found in the tab 'Stations':

In template	Replace by
cat1.pdf	[File]
puppy.pdf	[File]

Select...

Delete station(s) in template file which have not been substituted

When borders of station file and substituted file do not fit, set task status to:

Provide info  
 Generate a warning (The task will continue)  
 Generate an error (The task will stop)

- The stations (referenced files in the template)) are shown in the column '**In template**'. The task input files are listed in the column '**Replace by**'.

**Changing or defining the "Replace by" stations:** Click on any name of a file in the column '**Replace by**' and you will see a list with options. These depend on whether the ticket you have open already has input files or not.

- <do not substitute>**: Select this to not replace that station. See the below described option **Delete station(s) ...** to decide what happens then.
- To replace it with the first task input file
- To replace it with the second task input file
- Etc.
- Select....** After selecting a station in the '**Replace by**' column, this button allows you to browse to another file (that was not already an input file for this ticket). Alternatively, use SmartNames.
- Delete station(s) in template file which have not been substituted.**
  - When selected, the not-replaced stations will, in the output file, be empty ("delete").

- When not selected, the not-replaced stations will, in the output file, be those from the template ("keep").
- **When the borders of a station file and substituted file do not fit**, you can set the task status to:
  - **Provide info**: The task will end in status 'OK'. The task details and log file will mention which stations did not have the same borders.
  - **Generate a warning**: Same info is given, the task continuous, creates an output file but ends in status 'Warning'.
  - **Generate an error**: Same info is given but the task stops and ends in status 'Error'. There is no output file.

**Tab 'CAD Options'**

This tab is only enabled when you selected a CAD file as a template. The other types of templates do not offer such information or do not allow it to be changed.

The options are identical as described in [this page](#) of the task **Step & Repeat CAD based (Classic)**.

**Tab 'Sheet'**

The options are identical as described in [this page](#) of the task **Step & Repeat CAD based (Classic)**.

**Tab 'Plate'**

This tab is only enabled when you selected a CAD file as template. The other types of templates do not offer such information or do not allow it to be changed.

The options are identical as described in [this page](#) of the task **Step & Repeat CAD based (Classic)**.

## 6.208. Step & Repeat Template based

---

**Concept**

Use this task to place one-ups (print items) onto grids described in a template file.



**Important:** This task is one of the tasks that uses the graphics engine from ArtPro+ (NDL). This also means that the print marks are of the type Dynamic Marks.

To create a Step & Repeat PDF, this task needs this info:

- Specification of the layout, which could be made of one or multiple grids.
- Specification of the one-up(s) to be placed on those grid(s); their name and location.
- Specification of any other attributes, for example print marks.

This task can get these specifications from different types of files.

For example:

- When the task's input files are the one-up PDF files, then the template file indicated in the ticket will need to provide the specification of the grid(s).

- But when the task's input file already describes all of the specifications listed above, then the ticket does not need to have a template indicated. There is a JDF format that can describe both the grids and the list of required one-ups to place.

These capabilities make it possible to use this task in 3 different modes.

### 3 Modes to Use this Task

- Where the input file(s) are the one-up PDF file(s). In the ticket, you then define the template and any other settings. Learn more [here](#).
- Where the input file is an XML RunList (a list of one-ups to process). In the ticket, you then define the template and any other settings. Learn more [here](#).
- Where the input file is a *JDF LanePrintJob*" file. This type of JDF defines both the template and the RunList. Learn more [here](#).

### Task Options - Job level

- **Template:** Select the template file that describes the grid(s).

When a template is selected, all other information in this task ticket is automatically filled in with information from the template. You can not make changes to those fields..

These file formats are supported as template file:

- an SRT file, created in [PowerLayout Standalone](#), an Esko plug-in for Adobe Illustrator. Learn more in [the manual of PowerLayout Standalone](#).
- a PDF with PowerLayout grid(s), created in ArtPro+.



#### Attention:

- When using a template with multiple grids, the task must have the same amount of input files.
- Each grid in the template must have a different name.

- **Optimize Output for VDP:**

This option is similar to the 'Optimize output' as used in the task [Add Dynamic Marks](#), but goes much further in changing the output file:

- It not only calculates the marks just once and then re-uses them (leaving all marks expanded, i.e. dead objects),
- in this step & repeat task it also expands the grids and removes all links to the one-ups.

The optimization is both in the speed of this task itself and in the size of the output file. This makes it most valid for the layout of VDP jobs.

This is an output optimization, so clearly something you will not do when you still want to modify the layout file in ArtPro+.

- **Automatically:** Depending on the content of the input file (whether it contains VDP type objects), the task decides whether to do this optimization or not.
- **No:** The task adds and evaluates the added marks on each page separately. The PDF+ marks also stay live objects: when you open the output in ArtPro+, you see the marks' properties and you can modify them. Also the grid objects will still be live grid objects.

In older versions of this task, this option was called "Calculate for each page (more accurate)".

- **Yes:** The task calculates the marks only once and then copies them to all pages. Both the marks (all types) and grids are stored as dead objects.

In older versions of this task, this option was called "Calculate once and copy (faster)".



**Note:** Selecting this option will make the task fail when the input file contains a Plate ID object (mark). This type of object may not be expanded before it was applied to a LENX file. Learn more in [Working with Plate ID](#) on page 1554.

- **Split Output options:** Learn more in [this page about the S&R Tabular task](#).

### All Other Task Options

Learn about all the other options in [this page about the Step & Repeat Tabular task](#).



**Attention: Filling Order** is not applied globally. Therefore, when you specify the filling order for each grid separately, ensure that the number of grids in this ticket matches the number of grids in the template file.

### Importance of the Order of the Input Files

The order of the input files is especially important when you work with templates. Input files are considered alphabetically, i.e. the order in which you selected the one-up PDFs is not relevant.



**Tip:** Use the '[Sort](#)' workflow control to change this sequence of input files as they enter this task.

Learn more in [this page valid for both S&R tasks](#).

## 6.208.1. Using PDF input file(s)

### Concept

Template driven Step & Repeat is typically used when you have several same-size variations of a one-up.

Below example shows that making that layout in an editor once is enough (PowerLayout grids in ArtPro + or PowerLayout plug-in in Adobe Illustrator). The next layouts with the other one-ups can be done with this task using that initial layout as template.

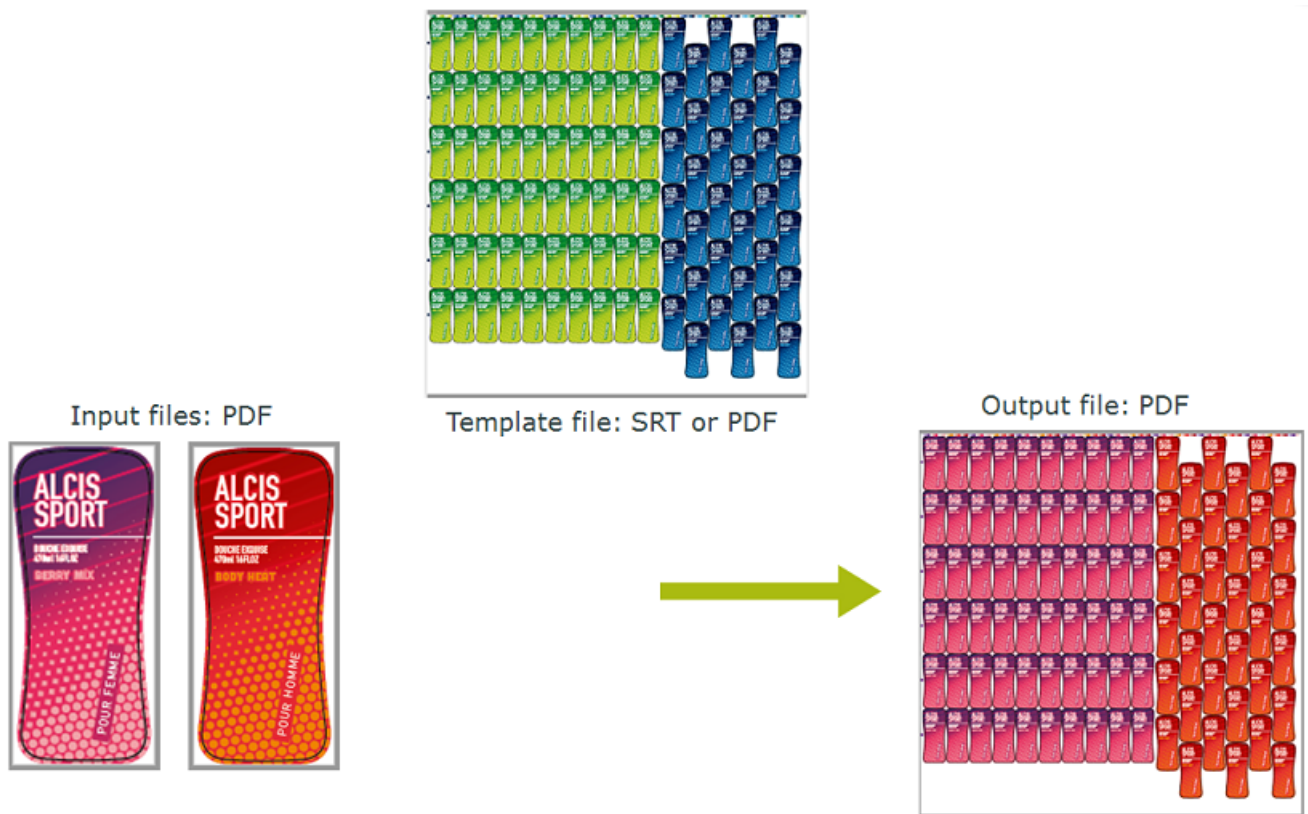

**Note:** However you select the input files, they will be handed over alphabetically to the task. The alphabetically first one will be assigned to grid 1, etc. This means that when the template's grids have stations of a different size, that you may need the *Sort* step in front of this task to control which input file is assigned to which grid.

**About Marks**

The marks in the output file can be the Dynamic Marks that were present in the template (PDF from ArtPro+) or other they could be Dynamic Marks added by this task, or even a combination. The marks will obviously adapt to the new input files (colors , etc.).

Marks from an SRT template will not adapt to the new input files ; those have become fixed objects.

**6.208.2. Using RunList XML as input file**

This is the same as described for the task *Step & Repeat Tabular* on page 483.

See its dedicated page [Specification of RunList XML in Step & Repeat tasks \(= excl. the Classic ones\)](#) on page 496

### 6.208.3. Using JDF as Input File

#### Concept

When external systems have all the information that this task needs, which one-up(s) and which grid(s) to use, they can deliver this information as a *JDF LanePrintJob* file. Find an example and its specification below.

As with all system integrations, Esko's [Solution Services](#) can assist you in this project.



**Note:** This mode, with a JDF input file, enables this task to replace the task [Import JDF Layout](#) which uses a different graphics engine (BRIX, used in normalized PDF). This task is one of the tasks that use the NDL graphic engine from ArtPro+ (fka the "Dynamic" tasks).



**Note:** When this kind of JDF is the task's input file, then the **Template** field in the ticket should stay empty.

#### Example of a JDF LanePrintJob file

We here describe the layout in which lanes only contain (repeats of) 1 product. Learn more below about the VDP use case where a lane can contain (repeats of) different products.

See the example JDF file below. You can also download it from [here](#). It creates this multi grid layout, 3 grids ; the middle with 2 lanes:



```
<?xml version="1.0" encoding="UTF-8"?>
<JDF xmlns="http://www.CIP4.org/JDFSchema_1_1" ID="0000" Type="ProcessGroup"
  Types="ImpositionPreparation" Status="Ready"
  JobID="01234556" JobPartID="1" Version="1.3" xmlns:eg="http://www.esko-graphics.com/
EGSchemal_0">
  <ResourcePool>
    <eg:MultiGrid ID="Mg001" Class="Parameter" Status="Available"
  ProductID="MultiGrid124">
```

```

<eg:Grid Grid="0" CellH="65" CellV="150" GapH="0" GapV="0" NrH="1" NrV="3"
Rotate="0" VOffset="0" HOffset="0"/>
<eg:Grid Grid="1" CellH="150" CellV="65" GapH="0" GapV="0" NrH="2" NrV="6"
Rotate="90" VOffset="10" HOffset="70"/>
<eg:Grid Grid="2" CellH="65" CellV="150" GapH="0" GapV="0" NrH="1" NrV="3"
Rotate="180" VOffset="0" HOffset="370"/>
</eg:MultiGrid>
<eg:LanePrintJob ID="Pj001" Class="Parameter" Status="Available" MediaWidth="480"
MediaHeight="470" MediaMarginLeft="5.0">
<eg:LaneRepeat>
<eg:MultiGridRef rRef="Mg001"/>
<eg:Lane Lane="0" >
<RunList PartIDKeys="Run">
<RunList Run="1" NPage="1">
<LayoutElement>
<FileSpec MimeType="application/pdf" URL="file://myserver/mycontainer/
myfolder/ALCIS_SHOWER_BERRY.pdf"/>
</LayoutElement>
</RunList>
</RunList>
</eg:Lane>
<eg:Lane Lane="1" >
<RunList PartIDKeys="Run">
<RunList Run="1" NPage="1">
<LayoutElement>
<FileSpec MimeType="application/pdf" URL="file://myserver/mycontainer/
myfolder/ALCIS_SHOWER_KIWI.pdf"/>
</LayoutElement>
</RunList>
</RunList>
</eg:Lane>
<eg:Lane Lane="2" >
<RunList PartIDKeys="Run">
<RunList Run="1" NPage="1">
<LayoutElement>
<FileSpec MimeType="application/pdf" URL="file://myserver/mycontainer/
myfolder/ALCIS_SHOWER_KIWI.pdf"/>
</LayoutElement>
</RunList>
</RunList>
</eg:Lane>
<eg:Lane Lane="3" >
<RunList PartIDKeys="Run">
<RunList Run="1" NPage="1">
<LayoutElement>
<FileSpec MimeType="application/pdf" URL="file://myserver/
mycontainer/myfolder/ALCIS_SHOWER_ICE.pdf"/>
</LayoutElement>
</RunList>
</RunList>
</eg:Lane>
</eg:LaneRepeat>
</eg:LanePrintJob>
</ResourcePool>
<ResourceLinkPool>
<eg:LanePrintJobLink rRef="Pj001" Usage="Input"/>
<eg:MultiGridLink rRef="Mg001" Usage="Input"/>
</ResourceLinkPool>
</JDF>

```

**Specification of JDF LanePrintJob**

eg:MultiGrid of JDF[ @Category ]	Description	Cardinality
eg:Grid	Step & Repeat grid.	1-infinity
eg:Grid/@Grid	The index of the grid (0 based numbering).	1
eg:Grid/@CellV	The height (along the web) of the repetition cell (mm).	1

<b>eg:MultiGrid of JDF[ @Category ]</b>	<b>Description</b>	<b>Cardinality</b>
eg:Grid/@CellH	The width (across the web) of the repetition cell (mm).	1
eg:Grid/@VOffset	The vertical offset of this grid from the top of the multi-grid (mm).	1
eg:Grid/@HOffset	The horizontal offset of this grid from the left side of the multi-grid (mm).	1
eg:Grid/@Rotate	The rotation (degrees clockwise) to be applied to graphics in the cells. Value should be 0, 90, 180 or 270 .	1
eg:Grid/@NrV	The number of cells along the web.	1
eg:Grid/@NrH	The number of cells across the web.	1
eg:Grid/@GapV	The height (along the web) of the gap between cells in the repetition (mm).	1
eg:Grid/@GapH	The width (across the web) of the gap between cells in the repetition (mm).	1

<b>eg:LanePrintJob of JDF[ @Category= "MISPRE.ImpositionPreparation"</b>	<b>Description</b>	<b>Cardinality</b>
eg:LaneRepeat/eg:Lane/RunList /RunList[ @Run="1" ]/LayoutElement/FileSpec/@URL	Absolute file URL pointing to the PDF to upload. The PDF has to be stored on a network share that is readable by the AE System account.	
eg:LaneRepeat/eg:Lane/@Lane	The lane (zero base indexed from left to right).	1
eg:LaneRepeat/eg:Lane	Element defining the Lane of a Lane-Repeat. Lanes are numbered between 0 and NrH-1 from left to right.  It is allowed to omit lane elements. This will result in an empty lane.	1-infinity
eg:LaneRepeat	Repeat (a Step & Repeat PDF).	1
@MediaWidth	The width of the media box.	1
@MediaMarginRight	The margin provided on right of the trim box with respect to the media box.	0-1
@MediaMarginLeft	The margin provided on left of the trim box with respect to the media box.	0-1
@MediaHeight	The height of the media box.	1
@Bleed	The amount of bleed.	0-1



### Behavior

- When the task detects a JDF as input file, it checks if it has the JDF LanePrintJob format, and if it contains information about the grids and lanes.



**Attention:** When such a valid JDF is detected, the field **Template** in the task ticket should stay empty. Otherwise, the task will end in error.

- These fields are mandatory in the JDF file:
  - Grid and Lane index number
  - CellH, CellV
  - VOffset, HOffset
  - MediaHeight, MediaWidth
  - Rotate
  - GapH, GapV
  - NrH, NrV
- Bleed, MediaMarginLeft and MediaMarginRight are optional.
- When mandatory fields are missing or have a blank value, the task will end in error. For example: Rotate="" , GapH=""
- When optional fields are missing or have a blank value, the task considers those elements as missing. For example: Bleed="" , MediaMarginLeft=""
- No bleed will be applied if the attribute eg:Bleed is missing in the input.
- The grid index numbering should start from 0 and should be unique. The index numbering of the grids should be in sequential order.
- The trim box is defined as union of all grids taking into account their size and position. It is then enlarged to also contain the origin point [0,0].
- The media box size is defined by the MediaHeight and MediaWidth.
- The media box position is based on the size of the trim box.
  - Vertically: center according to trim box.
  - Horizontally:
    - If no margin is defined, also center.
    - If MediaMarginLeft is defined then that is the distance from the left side of media box to the left side of the trim box.
    - If MediaMarginRight is defined then that is the distance from the right side of media box to the right side of the trim box.
  - Finally, the media box is checked to verify that the complete trim box is inside. An error is generated if it is not the case.
- GapH, GapV can also have negative values.
- The one-ups to be placed in lane depend on LayoutElement/FileSpec/@URL and eg:LaneRepeat/eg:Lane.
- The PDF file path defined in the FileSpec/@URL in the input XML should be in URL or UNC format. The task will end in error if the input PDF file path in the XML file is invalid or the file doesn't exist.
- The task will place the one-ups according the provided lane number of the corresponding provided grids columns(NrH), this in numerical order of the grid index starting from 0.

- Corresponding grid columns will be blank if the lane index number is not provided.
- When any of the following conditions are not met, the task will end in error and show relevant log messages:
  - `MediaWidth / MediaHeight` must be  $> 0.0$
  - The media box must be  $\geq$  the trim box
  - `CellH, CellV` must be  $> 0.0$
  - `NrH, NrV` is whole number  $\geq 1$
  - `Bleed`, if present, must be  $\geq 0.0$
- `RunList` attributes with anything other than `Run="1"` `NPage="1"` will also result in error, except when you use the VDP mode as described below.
- The tag `FileSpec` in `LayoutElement` is mandatory.

### Different Products in a Same Lane (VDP mode)

Above is described how the task works with a JDF describing the single page mode. That is where each lane (column) is either completely filled with the same one-up (or the lane is empty). The one-ups (pages) are repeated to fill the complete lane. The task outputs 1 layout (1 output sheet).

When a JDF `RunList` describes at least one lane that contains two or more different products ('input pages') then the here described VDP mode (variable data printing) is used.

- In VDP mode, each lane contains only the pages explicitly mentioned in a `RunList`. These can be
  - one or more pages from single file
  - a page range from a single file
  - the same pages repeated multiple times
  - a combination of multiple pages from multiple files.

However, only the one-up pages as defined by a `RunList` are used ; in this mode, lanes are not automatically filled 'till the end of the page'.

- Input pages are filled into lanes and the longest lane defines the number of output pages. Filling of each lane starts from the top (of the first page).
- The `RunList` definition generally follows standard JDF `RunList` specification with one exception: it is not allowed to define a `RunList` of an unknown number of pages. A page range cannot be unfinished like "0 ~ " (from the first page to the end of document). It must be explicit, for example "0 ~ 123".

In VDP mode, nothing changes to the above described definition of a grid (`<eg:MultiGrid>`).

The difference is in the lane definition:

- A `<eg:Lane Lane="0">` can now contain multiple `<RunList>` entries.
- And you are also not limited to a single page `NPage="1"`.

Some examples:

- **Example 1:** The selected page from the document is copied multiple times, using the attribute "DocCopies".

```
<eg:Lane Lane="2" >
  <RunList PartIDKeys="Run">
    <RunList Run="1" NPage="1" DocCopies="9">
      <LayoutElement>
```

```
<FileSpec MimeType="application/pdf" URL="file://server/container/folder/
file1.pdf"/>
  </LayoutElement>
</RunList>
</eg:Lane>
```

- **Example 2:** Specifying specific pages and/or page ranges. In below example the pages 0, 1, 2, 3, 6, 13 will be used.

```
<eg:Lane Lane="2" >
  <RunList PartIDKeys="Run">
    <RunList Run="1" NPage="6" Pages="0 ~ 3 6 13">
      <LayoutElement>
        <FileSpec MimeType="application/pdf" URL="file://server/container/folder/
file1.pdf"/>
      </LayoutElement>
    </RunList>
  </RunList>
</eg:Lane>
```

- **Example 3:** One single lane has multiple RunLists:

```
<eg:Lane Lane="0" >
  <RunList PartIDKeys="Run">
    <RunList Run="1" NPage="3" Pages="~ 1 0">
      <LayoutElement>
        <FileSpec MimeType="application/pdf" URL=" file://server/container/
folder/file1.pdf"/>
      </LayoutElement>
    </RunList>
    <RunList Run="2" NPage="1">
      <LayoutElement>
        <FileSpec MimeType="application/pdf" URL=" file://server/container/
folder/file2.pdf"/>
      </LayoutElement>
    </RunList>
  </RunList>
</eg:Lane>
```

## 6.209. Submit to Flexo CTP Device

This task is documented in the chapter [Flexo CTP Device Workflow](#) on page 1482. Find a direct link [here](#).



**Note:** Until AE v18.1.1, this task was named '[Submit to CDI](#)'.

## 6.210. Submit to Gang Run (Classic)

This task is documented in the chapter [Sign & Display Workflow](#) on page 953. Find a direct link [here](#).

## 6.211. Submit to HP SmartStream Production Pro Print Server

This task is explained in the chapter [Digital Printing Workflow](#) on page 1589. Find a direct link [here](#).

## 6.212. Submit to Esko DFE

---

This task is documented in the chapter [Digital Printing Workflow](#) on page 1589. Find a direct link [here](#).

## 6.213. Submit to Generic DFE (Pre-Release)

---

This task is documented in the chapter [Digital Printing Workflow](#) on page 1589. Find a direct link [here](#).

## 6.214. Submit to Kongsberg Table

---

This task is documented in the chapter [Kongsberg Production Workflow](#). Find a direct link [here](#).

## 6.215. Submit to Plate Merger

---

This task is documented in the chapter [Flexo CTP Device Workflow](#) on page 1482. Find a direct link [here](#).

## 6.216. Submit XML to Gang Run (Classic)

---

This task is documented in the chapter [Sign & Display Workflow](#) on page 953. Find a direct link [here](#).

## 6.217. Synchronize ArtiosCAD Boards

---

### What?

This task synchronizes 'board' information received from a business system with the ArtiosCAD 'board' database.

### More Info

This task is set up by an Esko Solution Architect. Learn about Esko Solution Services on <https://www.esko.com/support/solution-services>.

For more information, search for online articles on this topic in the [Esko Knowledge Base](#).

## 6.218. Synchronize ArtiosCAD Companies

---

### What?

This task synchronizes 'company' information received from a business system with the ArtiosCAD 'company' database.

### More Info

This task is set up by an Esko Solution Architect. Learn about Esko Solution Services on <https://www.esko.com/support/solution-services>.

For more information, search for online articles on this topic in the [Esko Knowledge Base](#).

## 6.219. Track Edit Session

---

Automation Engine can track and log interactive editing actions in Esko editors. Define [in the Configure tool](#) for which editors you want this automatic tracking.

When you open a file that resides in an active Job (folder) in an Esko editor, this task will automatically start logging many important editing actions. The task automatically stops when someone closes the file in the editor.

File Name	Task Type	Order ID	Progress	Phase	State	Launched
32386_yog.pdf	Prepare for Viewer	001234	100%		✔	12/9/16 4:25 PM
32386_yog_des_passion.pdf	Track Edit Session	001234	0%	Editing with PackEdge 16...	🔍	12/9/16 4:24 PM

This editing information can so also automatically

- be stored in the **Task History**.
- be made available by using **Notifications**, for example as an XML file to report to another system. You could also save all notifications locally in the Job folder or centrally and you can do this in one or several files. Learn more [here](#).



**Note:** This task cannot be launched interactively. It will start appearing when you [configured it](#). Keep in mind that the editor needs to be restarted to activate this setting.



**Note:** When editing files in ArtPro, the task only records the timings of opening and closing the file.

### 6.219.1. Viewing the Edit Session Information in the Pilot

In the Pilot, the task's **Details** already show what is logged. An example:

Job Name	Task Type	File Name	Progress	State	Launched
WDEs Graphics	Track Edit Session	03_astrid_BCK.pdf	0%		12/12/16 12:02 PM
WDEs Graphics	Track Edit Session	03_astrid.pdf	100%		12/12/16 11:40 AM

Details

Task Type: **Track Edit Session**

Started on Server: rdvmae17

Started at: 12/12/16 11:40:50 AM

Finished at: 12/12/16 12:02:14 PM

Process Time: 0:21:23

---

\*\*\* Start interactive PackEdge 16.0.0 \*\*\*

Time 12/12/16 11:40 AM

User wde@rdvmae17

Automation Engine server RDVMAE17

---

Loading file file://eaw11dl306/WDE-AE-DATA/Graphics/03\_astrid.pdf

Create layer Layer 1

Create layer Layer 2

Changed page margins to top 2.039195, bottom 0.1764173, left 0.1763889, right 0.1767041 mm

Creation or modification of barcode EAN 13 with code 5449000111654

Creation or modification of barcode EAN 13 with code 5449000111654

Saving file file://eaw11dl306/WDE-AE-DATA/Graphics/03\_astrid.pdf

Saving file file://eaw11dl306/WDE-AE-DATA/Graphics/03\_astrid\_BCK.pdf

---

\*\*\* End interactive PackEdge 16.0.0 \*\*\*

Time 12/12/16 12:02 PM



**Note:** Notice in above screenshot how, when at the end the operator saved the file as \*\_BCK, that the tracking task closed and immediately started a new one, now for the file with that other name.

## 6.219.2. Storing the Editing Information System-Wide

How can these edit logs be stored automatically?

- Make sure the task is automatically archived into the tool [Task History](#).
- Alternatively, use the [Notification tool](#) to create a rule specific for this task:
  - Either you save all these XML logs inside the Job folder. The SmartNames you use in the output location allow you to choose if you want one (XML/TXT) log for each file or one per day or etc.
  - Alternatively, you save all these XML logs per customer or even system-wide. In that case you just indicate an output path somewhere outside the Job folder.

Follow these steps to create such a rule:

1. Go to **Configure > Notification > Rules**
2. In the **Tasks** tab, select the task **Track Edit Session**.
3. Click **Add**. The **Notification Rule Editor** opens.
4. To get an XML, select the **Action 'Create XML File in folder'**.
5. Define the folder's **Location** and click **OK**.

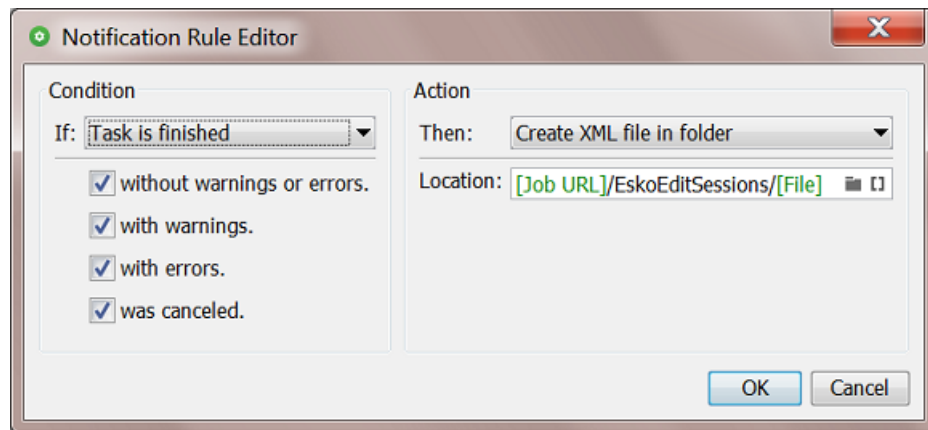

### 6.219.3. Which Edit Actions are Logged?

These types of edits are logged:

- Which user opens which file from which workstation?
- Start and stop time of this editing session
- Was the file saved or closed? When and with what name?
- All loading, saving, placing, exporting functions
- All changes to inks, layers, pages, page sizes
- All changes to (Esko) barcodes
- HIFI color conversions
- All trapping actions, PSFix actions, InkWizard actions
- Creating and replacing of external references
- Die object edits: adding, turning, flipping, rotating
- Writing of task notifications (when closing the edit session)
- Any loss of connection with the server.

An example:

```

*** Start interactive PackEdge 7.0 ***
Time 13/01/06 17:19
User wde@aeserver01
Automation Engine server AESERVER01
Loading file file://aeserver01/52355/Prod/52355_YummieBeer_back.pdf
Remove layer OMBRE
Trap with local ticket Default
"Modified ink angle for C from 22 to 7 degrees"
"Created ink PANTONE 123 C (100 lpi, 7 degrees, dot ?, type Normal)"
"Created ink C (170 lpi, 75 degrees, dot ?, type Normal)"
"Created ink ROUGE (170 lpi, 45 degrees, dot ?, type Normal)"
Placing file file://aeserver01/52355/Prod/52355_YummieBeer_collar.pdf
Changed page margins to top 3.998, bottom 9.998, left 4.001, right 66.001 mm
Changed page size to width 110.0024 mm and height 73.99 mm
PS-Fix: modified 2 contour(s)
Applied Job inkmapping
"Modified ink angle for C from 7 to 75 degrees"
"Removed ink M (170 lpi, 15 degrees, dot ?, type Normal)"
    
```

```
Changed page margins to top 7.25, bottom 7.25, left 7.25, right 8.36 mm
Exporting file file://aeserver01/52355/Prod/52355_YummieBeer_back.tif
Saving file file://aeserver01/52355/Prod/52355_YummieBeer_back2.pdf
*** End interactive PackEdge 7.0 ***
Time 13/01/07 17:22
Notification:Wrote XML file:E:\wdedata\52355\Prod\Edits\52355_YummieBeer_back.
```

## 6.220. Trap

---



**Note:** This task uses the graphic kernel of PDF Action List Processor.

This task accepts PDF as input file (PDF+ and Normalized PDF).

This task will overwrite the input file when you didn't specify a different name or location.

The task used the units specified in the preferences of the Pilot.

All required values of SmartName fields are case-insensitive.

### Task Settings



- **Use Trap Settings from File:** In ArtPro+, you can save trap settings, even per object.
  - **Never.** You then define all options here in this ticket.
  - **When Available:** Select this when you want to use settings that are present in the input file. The task ends in error when no such settings are found.

When using a SmartName, its value must be either 'When Available' or 'Never'. These fields is case-insensitive. The default option selected is 'Never'.

- **Trap Distance:** Enter the width of the traps. The default width is 0.2 mm (or its equivalent in *your chosen unit*).
- **Truncate:** Truncate the trap so that it doesn't stick out on another color. Select 'On Center' or 'On Edge'. When using a SmartName, its value must be either 'Center' (default) or 'Edge'.
- **Joins:** How should the sharp corners of the traps be handled? Select 'Round' or 'Mitered'. When using a SmartName, its value must be either 'Round' (default) or 'Mitered'.
- **End Caps:** 'Object Dependent' means a logical continuation of the contour of the spread object. 'Square' ends the trap at right angle to the adjoining object. SmartName values must be 'Dependent' (default) or 'Square'.

- **Image Traps:**
  - **Original Data:** When spreading an image, the task uses the underlying image data (when the image is clipped) to create the trap. SmartName value must be 'Original'.
  - **Extend Data:** The task automatically extrapolates the image along its clipping path edge to ensure the trap looks as expected, even if there is no clipped image data outside the visible image. SmartName value must be 'Extend'.
- **Apply Pullback:** When a color area is composed of multiple inks bordering to a very light background, you can 'pull back' all inks except the darkest ink. This prevents individual inks from that composed color to become visible in the background.
  - **Inherit Trap Settings:** When set to 'yes', the same settings will be used as those set above for trapping. SmartName value can be 'yes' (default) or 'no'.
  - **Pullback Distance:**
  - **Truncate:**
  - **Joins:**
  - **End Caps:**
- **Close gaps smaller than:** Some files contain very small unintentional gaps between neighboring objects. These gaps prevent trapping of these objects.  
The default value is 0.01 mm
- **Allow Overshoot:** Indicate if you want to allow trap objects to overshoot out of the (thin) objects that they are trapping in to. Learn more in the [user guide of ArtPro+ \(Prepress functions > Trapping\)](#).
- **Trap highlights for flexo print:**  
Select this if you still want to trap small color differences that would normally not be trapped. You may want to do this when you expect these color differences to become bigger when using DGC bump-up curves.  
Define a range between 0 - 100% for the 3 parameters **First Printable Dot**, **Print as** and **Range**.  
Learn more about these parameters in the page about the Viewer's [Flexo Print Preview](#) on page 1113.

## 6.221. Trap with PowerTrapper (Classic)

---

Learn about the concept of trapping in [What is Trapping?](#) on page 517.

This task uses the classic Esko technology "PowerTrapper" (as a part of Esko's older graphic kernel 'BRIX').

Its input file needs to be a native or normalized PDF.

The resulting trapping objects are created in a dedicated (new) layer.

The output of this task is a Normalized PDF file.

The task's many settings are spread over these tabs:

- [Distance & Direction](#) on page 517
- [Color & Shape](#) on page 520
- [Processing](#) on page 521

- [Rules](#) on page 522
- [Output](#) on page 524

### 6.221.1. What is Trapping?

The **trapping** process is a safeguard against possible fluctuations in the printing process. Minor discrepancies in registration and slight paper shifting can cause inks to misregister.

When two adjoining colored objects do not touch exactly, the printed result can show a white gap, as well as areas with a dark overlap:



'Trapping' these objects causes the objects to slightly overlap each other:



In general, trapping is necessary when two adjoining color areas don't share a common ink.

Adding a fine area where they join, made of a color that contains components of both adjoining colors, can effectively 'trap' such areas.

### 6.221.2. Distance & Direction

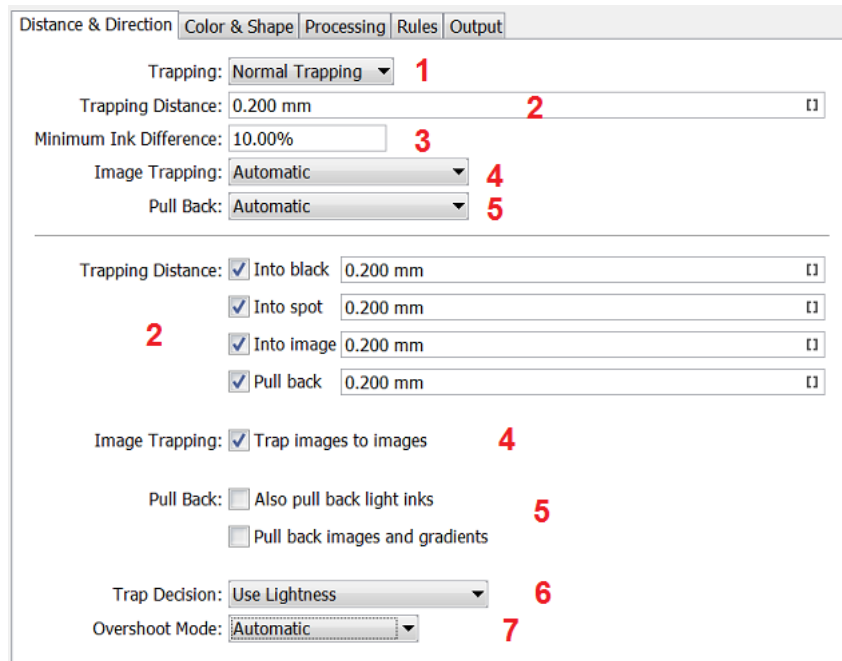

**1. Trapping:** Choose between two modes:

- **Normal Trapping:** This selects adjoining color pairs, which are likely to cause registration problems like ugly light gaps, and unwanted halo effects. Lighter colors are generally trapped into darker colors to minimize the visual effect of the trap.
- **Reverse Trapping:** This mode avoids overprinting of inks. It prevents overprint of adjoining color areas by trapping these color pairs with a white knockout (erasing) trap. The white knockout trap is put on top of the lighter of the two colors. This is useful to prepare a file for "Dry Offset" printing (example: printing on metal cans).

**2. Trapping Distance:** Enter the width of the traps. The default width is 0.2 mm (or its equivalent in *your chosen unit*).

Below, you can define specific distances when trapping **Into black**, **Into spot** color, **Into image** or adding a **Pull Back** (see below).

**3. Minimum Ink Difference**

Trapping is applied to two adjoining colors, when either:

- The two colors each consist of at least one ink but they have no common inks.
- The two colors have common inks but there is a difference of at least the **Minimum Ink Difference** percentage for two or more inks making up these colors.

These differences in ink percentages must be in opposite directions.



**Note:** An example: With the default minimum ink difference percentage of 10%, the following two colors are trapped:

- 1st color: C 5%, M 10%, Y 50%, K 15%
- 2nd color: C 5%, M 10%, Y 85%, K 5%
- => These colors have 2 inks that differ 10% or more: K is 10% different, Y is 35% different.

Increase the **Minimum Ink Difference** to trap colors that differ more ; lower it to trap colors that are similar.

#### 4. Image Trapping

- **Automatic:** This determines the most suitable trap direction automatically. It compares the average lightness of the image with the lightness of the adjoining area, and then traps the lighter color into the darker one.
- **Always Towards Image:** This always traps line art under adjoining images.
- **Always Towards Line Art:** This always traps images under adjoining line art.

Select '**Trap images to images**' if you want images to be trapped with each other.

#### 5. Pull Back

When a color area is composed of multiple inks bordering to a very light background, you can '**pull back**' ink to keep away all ink except the darkest ink. This prevents individual inks from that composed color to become visible in the background, typically due to registration errors during printing.

- **Automatic:** This creates pull backs on **rich black** or rich spot colors, when the color left in the pull back area is not very different from the composed color.
- **Only Pull Back Rich Black:** This only creates pull backs on **rich black**.
- **Do Not Pull Back:** This never creates any pull back.

There will be automatic pull back for the darkest color. Select '**Also pull back light inks**' to create pull backs even when the pull back ink (i.e. the ink remaining in the pull back area) is visibly different from the composed color. Select '**Pull back images and gradients**' to create pull backs on images and gradients.

#### 6. Trap Decision

- **Use Lightness:** This uses the color luminance to define the trapping direction, except for opaque inks, where it uses the inks order.
  - Trap direction: from brightest to darkest.
- **Treat Spot Colors as Opaque:** Color luminance is used only for CMYK. For opaque and spot inks, the trap direction is determined by the ink sequence.
  - Trap direction for spot colors only: towards the separation that is listed the lowest in list of inks.
  - Trap direction goes from the process to the spot color if the spot color is below the process color in the list of inks.
  - Trap direction if the spot color is above the process color: from brightest to darkest.
- **Use Separation Order:** The trapping direction is determined by the ink sequence for all inks, including CMYK.
  - Trap direction: towards the separation listed the lowest in the list of inks.
- **Use Reverse Separation Order:** As above, but using the reverse ink sequence.
  - Trap direction: towards the separation listed the highest in the list of inks.

7. **Overshoot Mode:** See some visual examples in the [PackEdge user manual](#) (**Menu > Trapper > PowerTrapper**).
- **Automatic:** The centerline behavior is according the rules determined in the color pair list.
  - **Never on Dark Areas:** The centerline is forced not to get beyond the center of dark areas.
  - **Never:** The centerline is forced not to get beyond the center of any area.

### 6.221.3. Color & Shape

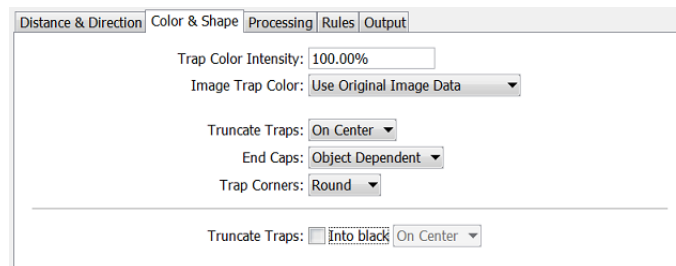

- **Trap Color Intensity:** By default, the task uses the full color of the object to spread in the trap area (100% trap color intensity). You can create a trap of a lighter color by reducing this percentage.
- **Image Trap Color:** Choose how to trap your images:
  - **Use Original Image Data:** When the image is clipped, the task uses the underlying image data to create the trap. When there is no underlying image data (when the image is not clipped), an empty trap is created.
  - **Extend Image Data:** The task automatically extrapolates the image along its four edges to ensure that the trap looks as expected, even if there is no clipped image data outside the visible image.
  - **Use an Approximate Flat Color:** Instead of using existing or extrapolated image data in the trap, the task uses a solid color. A suitable color is determined by averaging the image's colors along its boundary with the object to trap.
- **Truncate Traps:** Truncating the trap object avoids that it sticks out on another color. Choose a mode:
  - **On Center:** When a portion of a trap comes too close to the contour of another object, it is limited to half the distance between the trapped object and the other object.
  - **On Edge:** When a portion of a trap comes too close to the contour of another object, it is truncated on the other object's edge.
- **End Caps:** Choose the shape of the ends of an open trap:
  - **Square:** The trap ends at a right angle to the adjoining object.
  - **Round:** This rounds the ends of the trap. This is typically only used in combination with white knockout ('Reverse Trapping').



**Note:** We recommend that you do not to use '**Round End Caps**' together with '**Truncate Traps On Center**', as this can generate some artefacts (the round caps are truncated).

- **Object Dependent:** The trap is a logical continuation of the contour of the spread object.
- **Trap Corners:** Choose how sharp corners should be handled:

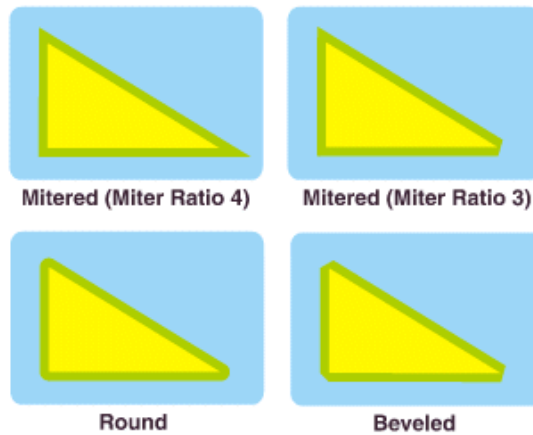

- **Round:** Corners end in a round cap.
- **Beveled:** Sharp corners are cut off.
- **Mitered:** If the distance from the base of the trap to the corner point is larger than the **Miter Ratio** multiplied by the trap distance, then the corner will be **beveled**, otherwise it will remain sharp.

The default miter ratio is 4. This means that if the length of the sharp corner is more than 4 times the **Trapping Distance**, the corner is cut off (beveled). If it is less than 4 times the **Trapping Distance**, the corner is left as it is.

- **Truncate Traps:** If you want to truncate traps into black differently, select **Into black** and choose the truncation mode (**On Center** or **On Edge**).

### 6.221.4. Processing

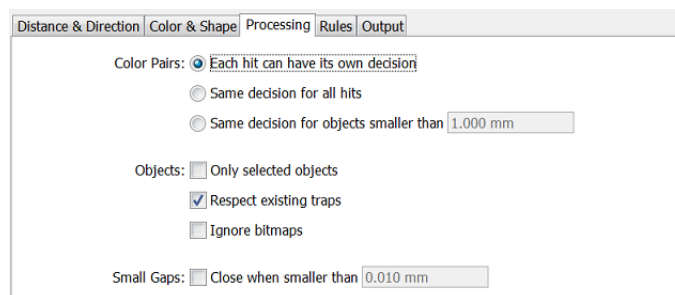

- **Color Pairs:**

Before creating trap objects, PowerTrapper scans the file for color pairs where this will be needed. A color pair can occur only once or it can occur many times. The task can trap all hits (occurrences) of a color pair in the same way or it can recalculate the trap direction for different hits.

- **Each hit can have its own decision:** This recalculates the trap direction for each hit of a color pair.
- **Use the same decision for all hits:** This traps all hits of the same color pair in the same direction.
- **Use the same decision for objects smaller than:** This uses the same trap direction for hits of a color pair belonging to small objects, and recalculates the trap direction for hits belonging to bigger objects.

Use the input field next to determine the maximum size of small objects.

- **Objects:**

To speed up the trapping, the task can safely ignore certain object types.

- **Only selected objects**
- **Respect existing traps:** If the file has already been trapped, select this option to keep the existing trap layer out of the trapping process.
- **Ignore bitmaps:** Select this to keep bitmap pixel data from being trapped. Bitmap data is contourized before trapping which may slow down trapping. Bitmaps with lots of small isolated islands typically take a longer time to trap.



**Note:** When you indicate an object type to ignore, it is ignored completely as if it did not exist in the file. Also, the ignored objects do not truncate trapping areas resulting from other objects below them.

- **Small Gaps:**

Some files contain very small unintentional gaps between neighboring objects. These gaps prevent trapping of these objects. Although it is better to clean up such files before trapping, PowerTrapper can ignore these gaps automatically.

To use this option, select **Close when smaller than** and enter the maximum size small gaps can have.



**Note:** If you set a big gap size, trapping may become slower and some small parts may be ignored.

## 6.221.5. Rules

This tab allows to add rules that define custom trapping settings for specific trapping pairs.

PowerTrapper first traps the trapping pairs that match such a rule (according to that rule) and then traps the rest of the file according to the main trapping settings.

### When to use Rules?

In most cases the general trapping settings entered in '**Distance & Direction**' give you excellent results. You can refine them using rules.

Settings defined in rules overrule settings in the other tabs.



**Note:** This is an advanced feature. We recommend it for experienced users.



Some example cases to custom rules:

- To set a different trap distance for a specific spot ink. Sometimes you need a larger trap distance for spot inks if there is no other ink to help cover leaks on the press.
- To prevent trapping or ink pull back in specific cases. Depending on the type of the adjoining colors, trapping and/or pull back may be undesirable.
- To force a specific trap direction. When adjoining colors have a similar lightness level, PowerTrapper selects an arbitrary direction. You can use a rule to make it always use a particular direction for a color pair.
- To specify a different shape and/or truncation mode for certain color pairs. For example, you can choose to use **'On Center'** truncation when trapping under a 100% black line and **'On Edge'** truncation on all other color pairs.

### Creating a rule

1. Click **Add**.
2. In the dialog, use the **'From'** and **'To'** lists to specify trapping pair that you want to apply this rule to. Choose between **'Any Color'**, a particular ink (**Process**, **Spot** or **Opaque**), a particular object (**Image**, **Gradient** or **Empty Background**) or the **Registration Color**.



**Note:** When trapping a particular ink, you can also define its **'Minimum Density'** and if the **Color must be pure** (no other separation in the color object).

3. Choose the contents of the rule.

Most options are described in the previous pages. Here are some specific settings within these rules:

- **Direction Mode:** Select **'Into Both Colors'** to use bidirectional trapping. In that case, the trap goes half the trapping distance in each direction.
- **Horizontal/Vertical Distortion:** Set the percentage of the trapping distance to be used in V/H direction.

See an example where the trap was generated with no vertical distortion (so 100%, i.e. using the entered trap distance) and horizontal distortion set to 50% (i.e. half the trap distance).



You can use the **+** or **-** buttons to add or remove criteria to your rule.

4. Click **Add** to confirm and add the rule.

- After defining the rules, click **OK** to confirm this list of rules.

### 6.221.6. Output

- Trap layer only:** Select this to output a PDF containing only the trap layer.
- Load trap color pairs if present:** Select this to make the task use a TCP file that was created during a previous trapping action. The TCP file needs to have the same name as the input file and needs to be present next to the input file.

## 6.222. Unshare Job

---

This task is documented in the chapter [Sharing to Collaborate with other AE servers](#) on page 1685. Find a direct link [here](#).

## 6.223. Unzip

---

Use this task to extract files from a zipped archive.

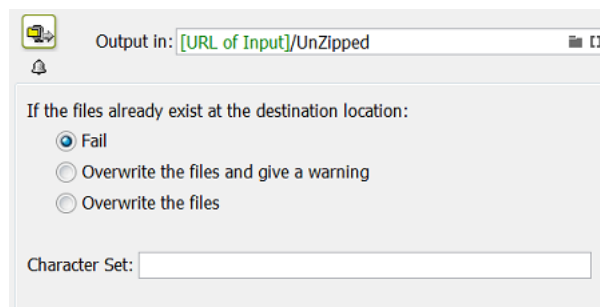

**Note:** Many applications can create zip files, also the [Zip task](#) in Automation Engine.

- Define what needs to happen **If the files already exist at the destination location:**
  - Fail.** The task will not unzip and will end in an error status.
  - Overwrite the files and give a warning.**
  - Overwrite the files.**
- Character Set:**

When a zip file was generated with non-standard encoding, unzipping such a file with this **Unzip** task can fail. The task's log file then mentions a 'MALFORMED' exception. You can solve this by specifying the character set that was used to create the file.

For the list of character sets and the correct naming to be used in this task ticket, we refer to [this page of the online java documentation](#). When specifying a character set in this ticket, use the name as is listed on that page, in the column "Canonical Name for java.nio API".

## 6.224. Upload Files to Shared Job

---

This task is documented in the chapter [Sharing to Collaborate with other AE servers](#) on page 1685. Find a direct link [here](#).

## 6.225. Upload Files to Share & Approve

---

This task is documented in the chapter [Integrating with Share & Approve](#) on page 1762.  
Find a direct link [here](#).

## 6.226. Update Linked Files

---

This task recursively updates links in PDF+ files.

When a grid or placed art inside a PDF+ file contains linked objects then these links will be updated recursively; all resource files having another linked file in the chain will be modified.



**Note:** The task allows Normalized PDF files as input but its functionality has no benefit because of the way Normalized PDFs only have external links to images (i.e. they by default always use the latest data of that link).

Linked objects can be PDF files, images and structural design files.

Dynamic Marks are also updated.

When a linked file is not accessible on its relative path, the task checks if it can be found on its original absolute path. If it cannot be found there either, the task ends in error.

The task lists all used and missing paths into the Details pane.

The task ticket has no options.

## 6.227. Upload Product to Esko Cloud

---

This task relates to near-line storage for AE SaaS customers.

Learn more in the chapter [AE SaaS: When your AE is in a Data Center](#) on page 1633, in the section about [Storing Products on Esko Cloud](#) on page 1658, on the page [Task 'Upload Product to Esko Cloud'](#) on page 1663.

## 6.228. Upload via FTP

---

This task is documented in the chapter [Integrating with External Systems](#) on page 1769. Find a direct link [here](#).

## 6.229. Upload via SFTP

---

This task is documented in the chapter [Integrating with External Systems](#) on page 1769. Find a direct link [here](#).

## 6.230. Upload To Cloud Storage

---

This task is documented in the chapter [Integrating with External Systems](#) on page 1769. Find a direct link [here](#).

## 6.231. Verify Certification

---

This task is documented in the chapter [Quality Control tools](#). Find a direct link [here](#).

## 6.232. Version PDF (Classic)

---

When working with various versions of a single PDF, such as multiple language versions or versions containing minor differences, you can use this task to save on output material by:

- **Combining a base file** with multiple **version files**.
- **Extracting separations or layers** from the base file and replacing them by variants.

### Combine Base with Version Files

By combining a **Base File** (the input file) with a number of **Version Files**, you can create various flavours of the same file and save on output material.

```
Base File.pdf + Job_v1.pdf = Combined_v1.pdf
                + Job_v2.pdf = Combined_v2.pdf
                + Job_v3.pdf = Combined_v3.pdf
```

You can use wild cards and/or SmartNames to specify folders or files.

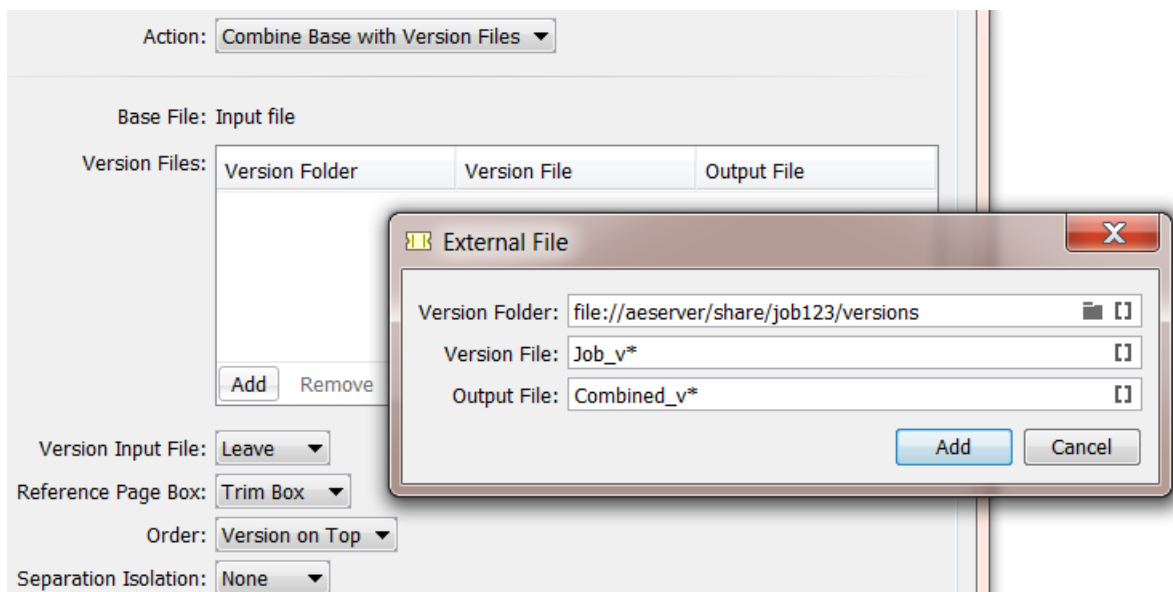

Here's a typical example: Your base file contains graphics and only the CMY separations. Your version files contain text in different languages in the black (K) separation. By combining the graphics from your base file with the various language versions, you only need to make the plates containing the separations for the graphics once.

Follow these steps:

1. In the **Version Files** table, click **Add**.
2. In the **External File** dialog, specify:
  - The location of the **Version Folder**, which contains the version files.
  - The name(s) of the **Version File(s)**, including their file extension.
  - The name of the **Output File**, which is a combination of the base file and a version file.
3. Choose what you want to do with the **Version Input File** (base file or input file):
  - If you want it to remain in the same place, choose **Leave**.
  - If you want it to be deleted, choose **Delete**.
  - If you want it to be moved to another folder, choose **Move to** and use the  button to define the new location.
4. Select the desired **Reference Page Box**. Selecting the correct media box here can prevent errors, such as double time stamps in the text of a page mark.
5. Determine the **Order** of the Base File and the Version file.
6. **Separation Isolation**: Select '**Isolated**' to use the PDF construct "Form Isolation" to combine the files, which will reduce the interaction between the content of the files. This is helpful when the files contain information for different separations, rather than artwork to be placed on top.



**Note:** You cannot combine Normalized PDF files with other PDF files.

### Extract Separations from Input file

This **Action** allows to extract a separation from the input file and map it to another separation. This is done to limit the total number of separations for output.

For example: Map a 'black' Pantone color that is used for text to 'K' (typically black in CMYK).

**Preserve Separation Interaction:** Use this parameter to define what to do when the separations you remove contain objects that knock out other separations.

- **None:** This only deletes knock-out objects that are only defined in the removed separation(s). Use this when removing separations that don't influence the final result (for example die cut separations).
- **Standalone:** This converts knock-out objects that are only defined in the removed separation(s) to white knock-out objects defined in one of the remaining separations. The remaining separations keep looking the same. This method is recommended for most use cases.
- **For Versioning:** This converts knock-out objects that are only defined in the removed separations to white overprinting objects. Those are defined in a color space made from the remaining separations of the file, and overprinting on all other separations.

This ensures that when re-adding separation layers for versioning, the final result looks the same as the original file.



**Note:** This may create objects in 'DeviceN' color spaces, which is something that some applications cannot handle. Only use this method if you want to do versioning on your file.

### Extract Layers from Input file

This **Action** allows to extract layers from the input file and split the input file into a fixed master and a variant part. The variable ink is often black.

Action:

Extract:

Base File: Input file

Base Layers:

Add Remove

Versioning Layers:

Layer Name	Output File
<input type="text"/>	<input type="text"/>
Add Remove	

You can also work with layers to extract the language layer from the input file and replace it with the corresponding translation(s).



**Note:** Work with wild cards to optimize your workflow: For example to only extract the language layer, use 'lang\_\*' if you know that all language versions follow this name rule. This will allow for the lang\_EN, lang\_FR and lang\_ES layers to be automatically extracted from the base file.

## 6.233. Wait

---

This task is documented in the chapter [Workflows](#), in the section [Inserting Wait Points](#) on page 750.

## 6.234. Wait for Action (Checkpoint)

---

This task is documented in the chapter [Workflows](#), in the section [Building Workflows # Inserting Wait Points](#).

Find a direct link [here](#).

## 6.235. Wait for Approval on Share & Approve

---

This task is documented in the chapter [Integrating with Share & Approve](#) on page 1762.

Find a direct link [here](#).

## 6.236. Wait for Files

---

This task is documented in the chapter [Workflows](#), in the section [Inserting Wait Points](#) on page 750.

## 6.237. Wait for Files (via JDF)

---

Use this task when you are working with a JDF RunList, and when the files referenced in the RunList are not ready yet.

Send the JDF RunList to this task, and it will check at a regular interval if the files are already present. When it finds all the files, it ends in OK and passes them on to the next workflow task.

### Example Workflow

1. The MIS system creates jobs via JDF, and sends the JDF RunList to your Automation Engine workflow.
2. The **Wait for Files (via JDF)** task checks if all the files referenced in the RunList are where they are supposed to be.
3. When the files are ready, the task finds them and passes them on to the next workflow task.
4. The rest of the workflow starts on the files.

### Parameters

- **Look in Folder**

By default, the tasks looks for the files at the location defined in the RunList. However, you can here define a custom location where the task should look for them.



**Tip:** For example, use the SmartName [URL of Folder of Input] if you know the files will be end up in the same folder as the RunList.

- **Stop waiting when time exceeds ...**

Select this if you want the task to finish if the files referenced in the RunList haven't been found after a specified time.

If you don't select this parameter, the task will wait indefinitely (or until it finds the files).

- **Task ends in error when not all files were found**

Select this if you want the task to finish with an **Error** state:

- When the time you set in the '**Stop waiting when time exceeds**' parameter has passed,
- **and** when the task hasn't found the files referenced in the RunList at that specified time.

## 6.238. Wait for Product Status

---

This task allows to hold a workflow until one or more **Products** have reached a certain status.



This task is documented in the chapter on [Products](#) on page 594. Find a direct link [here](#).

## 6.239. Zip

---

This task creates a zip file from the selected input file(s) or folder.

Choose the task's behavior in case the zip file already exists:

- **Generate an error**
- **Replace the zip file.**

Learn more in the page about [the Unzip Task](#).

## 6.240. Outdated and Soon Outdated Tasks in this Version

---

### 6.240.1. Concept of (Soon) Outdated Tasks / Features

#### Concept

Some technology in Automation Engine can become outdated after many years. There are two possible reasons for this:

- the functionality is now available via a new and improved technology. For example a task based on a new trapping engine replaces the old ones.
- the functionality is no longer used in today's prepress environment. For example a task to normalize EPF files, an Esko file format that is not created any more.

Such tasks or features are first declared "**Soon Outdated**" and later become "**Outdated**".



**Note:** Before version 14.1, the term `Deprecated` was used for **Soon Outdated** tasks and the term `Obsolete` was used for **Outdated** tasks.

#### Soon Outdated

A task or feature is named **Soon Outdated** as a warning that it will no longer be available in the next major version of the Automation Engine.

This gives you at least one year.

- to replace this task by an alternative. This could be a newer task equivalent or a slightly different workflow. The alternative is mentioned in this documentation.
- to contact Esko support in case the proposed alternative is not valid for you.

#### Outdated

A **Soon Outdated** task or features becomes **Outdated** in the next major version: it is then no longer available in that software version.

- Customers who never used that task type will not see any tickets.

- Customers who had already created custom tickets of that task type will still see those tickets but notice that they no longer work.

**A Gradual Process with Many Visual Reminders**

This two step process gives you the time to switch from using the old technology to the new version or method.

The Pilot shows you in many places which task types are (to be **Soon**) **Outdated**.

- In the **Tickets** list:

Task Type	Ticket Name
Add Marks to Imposition	Default
Add Parameters for Nesting (Soon outdated)	Default
Add SmartMarks	Default

Also workflow tickets that contain outdated tasks will show a warning:

Workflow	Import Export Test
Workflow ⚠ (contains 1 outdated step)	Jan
Workflow	Load Balanced Workflow

- In the task ticket itself, a colored top bar is added. A Soon Outdated task shows an orange bar and the link for **More Info** brings you to the online help page that describes the proposed alternative:

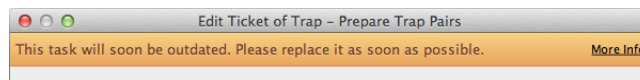

An Outdated task shows a red color bar and also a link with **More Info**:

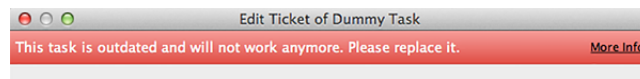

- In the **Workflow Editor**. Colored text indicates (soon) outdated workflow steps:

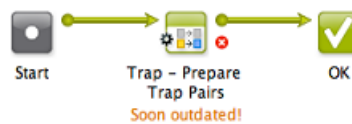

Transitions that depend on an outdated step are shown in grey. That part of the workflow also does not work any more:

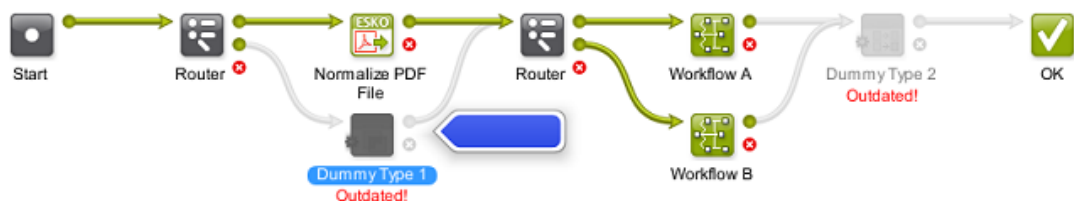

These (soon) outdated steps are also mentioned in the **Validate Workflow** dialog. When you there select such a warning, the corresponding step will also be highlighted in the workflow editor with an arrow.

Validate Workflow			
Warning	Node	Workflow	Description
Outdated Task	Trap - Create Trap Layer	/outdated test	"Trap - Create Trap Layer" is outdated and will not work...
Soon Outdated Task	Trap - Prepare Trap Pa...	/	"Trap - Prepare Trap Pairs" will soon be outdated. Please...



**Note:** Tasks can also be labeled 'Classic'. However this is just information to help avoid mixing classic technologies with recent ones. Learn more in [Which AE task Uses which Technology?](#) on page 66.

### 6.240.2. Expand Variable Data to PPML File (Classic) (Soon Outdated)

The **Expand Variable Data to PPML File** task will soon be outdated. Learn more about outdated and soon outdated tasks in [Concept of \(Soon\) Outdated Tasks / Features](#) on page 531.

This task was used in VDP workflows and used an older technology (the PPML file format).

Find a link below to its old documentation.

#### Alternative

Digital printing is a fast-evolving field, and the industry as whole is moving towards the PDF/VT file standard as a replacement for the older PPML standard. Esko is supporting this trend.

Esko recommends you to migrate to the **Dynamic VDP** workflow.

The **Dynamic VDP** workflow is based on PDF/VT and includes a DeskPack plug-in for authoring as well as an Automation Engine ticket for expansion.

#### Expand Variable Data to PPML File (Soon Outdated) - old documentation page



**Note:** Learn about the alternative for this task in the above page [Expand Variable Data to PPML File \(Classic\) \(Soon Outdated\)](#) on page 533.

The old documentation can still be found in older manuals of Automation Engine. To find it, go to

- <http://help.esko.com/products/Automation%20Engine>
- then, in "**Version**", select a version older than version 14
- click on the link to the **Reference Guide**
- go to **The Tasks: an Overview > Deprecated and Obsolete Tasks > Expand Variable Data to PPML File (Deprecated)**.

### 6.240.3. Expand Variable Data to PPML File (DeskPack Only) (Classic) (Soon Outdated)

The **Expand Variable Data to PPML File (DeskPack Only)** task will soon be outdated. Learn more about outdated and soon outdated tasks in [Concept of \(Soon\) Outdated Tasks / Features](#) on page 531.

This task was used in VDP workflows started from Adobe Illustrator and used an older technology (the PPML file format).

This task was documented in the page describing the non-DeskPack version: Find a link in [Expand Variable Data to PPML File \(Soon Outdated\) - old documentation page](#) on page 533.

**Alternative**

As mentioned in [Expand Variable Data to PPML File \(Soon Outdated\)](#), the alternative here is also to use the **Dynamic** workflow tools. This **Dynamic** workflow is based on PDF/VT and includes a DeskPack plug-in for authoring as well as an Automation Engine ticket for expansion.

**Expand Variable Data to PPML File (DeskPack only) (Soon Outdated) - old documentation page**

This task is the version of [Expand variable Data to PPML file](#) that can be started from DeskPack.

**6.240.4. Print on Digital Press (PPML) (Soon Outdated)**

This task will soon be outdated. Learn more about outdated and soon outdated tasks in [Concept of \(Soon\) Outdated Tasks / Features](#) on page 531.

The **Print on Digital Press (PPML)** task was used to create variable print jobs on the DFE server using the format PPML.

Find a link below to its old documentation.

**Alternative**

Digital printing is a fast-evolving field, and the industry as whole is moving towards the PDF/VT file standard as a replacement for the older PPML standard. Esko is supporting this trend.

Esko recommends you to migrate to the **Dynamic VDP** workflow.

The **Dynamic VDP** workflow is based on PDF/VT and includes a DeskPack plug-in for authoring as well as an Automation Engine ticket for expansion.

**Print on Digital Press (PPML) (Soon Outdated) - old documentation page**



**Note:** Learn about the alternative for this task in the above page [Print on Digital Press \(PPML\) \(Soon Outdated\)](#) on page 534.

The old documentation can still be found in older manuals of Automation Engine. To find it, go to

- <http://help.esko.com/products/Automation%20Engine>
- then, in "**Version**", select a version older than version 14
- click on the link to the **Reference Guide**

- go to **The Tasks: an Overview > Print on Digital Press (PPML)**.

### 6.240.5. Rip to WS4000 Series (Soon Outdated)

The **Rip to WS4000 Series** task will soon be outdated. Learn more about outdated and soon outdated tasks in [Concept of \(Soon\) Outdated Tasks / Features](#) on page 531.

This task was used to generate JLYT output for an HP Indigo WS4000 press.

Find a link below to its old documentation.

#### Alternative

Your alternative is to use the more recent [Print on Digital Press](#) on page 1614 task. This task links to the DFE that you configured in [Digital Press](#) on page 190.

#### Rip to WS4000 Series (Soon Outdated) - old documentation page



**Note:** Learn about the alternative for this task in the above page [Rip to WS4000 Series \(Soon Outdated\)](#) on page 535.

The old documentation can still be found in older manuals of Automation Engine. To find it, go to

- <http://help.esko.com/products/Automation%20Engine>
- then, in **"Version"**, select a version older than version 14
- click on the link to the **Reference Guide**
- In the **search** field, type WS4000. The result will show a link to the task's old documentation.

### 6.240.6. FlexRip tasks (Soon outdated)

These FlexRip tasks were declared 'Soon outdated' in AE 23.07.

- [Proof \(FlexProof\)\(Soon Outdated\)](#) on page 536
- [Proof IMP File \(FlexProof\)\(Soon Outdated\)](#) on page 536
- [RIP IMP File to Screened and Unscreened Tiff File \(Soon Outdated\)](#) on page 536
- [RIP to Screened and Unscreened DCS File \(Soon Outdated\)](#) on page 536
- [RIP to Screened and Unscreened PDF File \(Soon Outdated\)](#) on page 536
- [RIP to Screened and Unscreened PostScript File \(Soon Outdated\)](#) on page 536
- [RIP to Screened and Unscreened Tiff File \(Soon Outdated\)](#) on page 537

#### Alternative for FlexRip tasks

The alternative is to use Imaging Engine, Esko's more recent RIP and Proof application, based on Adobe technology.

The product Imaging Engine has its [own documentation pages](#).

Its user guide is also added to this AE complete manual as a chapter: [RIP'ing with Imaging Engine](#) on page 1178.

### **Calculate Ink Key Settings (InkPlanner) (Soon Outdated)**

In Automation Engine 23.07 this task type was declared to be 'Soon Outdated' . Learn about this concept in [Concept of \(Soon\) Outdated Tasks / Features](#) on page 531.

The old documentation can still be found in older manuals of Automation Engine.

### **Proof (FlexProof) (Soon Outdated)**

In Automation Engine 23.07 this task type was declared to be 'Soon Outdated' . Learn about this concept in [Concept of \(Soon\) Outdated Tasks / Features](#) on page 531.

The old documentation can still be found in older manuals of Automation Engine.

### **Proof IMP File (FlexProof) (Soon Outdated)**

In Automation Engine 23.07 this task type was declared to be 'Soon Outdated' . Learn about this concept in [Concept of \(Soon\) Outdated Tasks / Features](#) on page 531.

The old documentation can still be found in older manuals of Automation Engine.

### **RIP to CDI LEN File (Soon Outdated)**

In Automation Engine 23.07 this task type was declared to be 'Soon Outdated' . Learn about this concept in [Concept of \(Soon\) Outdated Tasks / Features](#) on page 531.

The old documentation can still be found in older manuals of Automation Engine.

### **RIP IMP File to Screened and Unscreened Tiff File (Soon Outdated)**

In Automation Engine 23.07 this task type was declared to be 'Soon Outdated' . Learn about this concept in [Concept of \(Soon\) Outdated Tasks / Features](#) on page 531.

The old documentation can still be found in older manuals of Automation Engine.

### **RIP to Screened and Unscreened DCS File (Soon Outdated)**

In Automation Engine 23.07 this task type was declared to be 'Soon Outdated' . Learn about this concept in [Concept of \(Soon\) Outdated Tasks / Features](#) on page 531.

The old documentation can still be found in older manuals of Automation Engine.

### **RIP to Screened and Unscreened PDF File (Soon Outdated)**

In Automation Engine 23.07 this task type was declared to be 'Soon Outdated' . Learn about this concept in [Concept of \(Soon\) Outdated Tasks / Features](#) on page 531.

The old documentation can still be found in older manuals of Automation Engine.

### **RIP to Screened and Unscreened PostScript File (Soon Outdated)**

In Automation Engine 23.07 this task type was declared to be 'Soon Outdated' . Learn about this concept in [Concept of \(Soon\) Outdated Tasks / Features](#) on page 531.

The old documentation can still be found in older manuals of Automation Engine.

### RIP to Screened and Unscreened Tiff File (Soon Outdated)

In Automation Engine 23.07 this task type was declared to be 'Soon Outdated' . Learn about this concept in [Concept of \(Soon\) Outdated Tasks / Features](#) on page 531.

The old documentation can still be found in older manuals of Automation Engine.

## 6.240.7. Tasks that became Outdated in this Version 23

In this version of Automation Engine, these tasks were removed because they became **Outdated** (they were earlier announced as "**Soon Outdated**"):

- < none >



**Note:** Learn more about how and when tasks become outdated in [Concept of \(Soon\) Outdated Tasks / Features](#) on page 531.

## 7. Jobs

---

### 7.1. Job Basics

---

#### 7.1.1. The Job Concept

##### What is an Automation Engine Job?

An Automation Engine Job represents an amount of work to be done for a certain order in your business system. This can be a classic order management system but it could also come from a web application that needs Automation Engine to execute some prepress tasks.

A Job is an entry in the Automation Engine Jobs database and has a unique name. In the Pilot, Jobs are represented by this blue folder icon .

In Automation Engine, a Job consists of 2 things:

- **Data:** Files and folders, stored under the Job's **Job Folder**, in a Container.
- **Metadata:** The parameters of that job order, usually how the order management system describes this job. They can be general parameters like the job's name, order ID, customer and due date but can also be parameters describing what to do with the input files to get to the targeted result.

Jobs can be created manually by an Automation Engine user or automatically via some integration with an external system.

A Job represents Work In Progress (WIP). This means that you should remove Jobs that are 'done'. Removing a Job from the Automation Engine Jobs database does not mean that you have to delete the related data files.



**Note:** AE SaaS users can inactivate old Jobs by moving them to Esko Cloud. Learn more in the chapter on [AE SaaS](#).

##### Most Automation is based on Jobs

A lot of the automation that Automation Engine brings comes from the fact that tasks can automatically use parameters from their Job context. Job parameters automatically become SmartNames and the (workflow) task tickets can use those SmartNames to pick up their values.



**Note:** Customers that do not use Jobs at all find a similar level of automation by using **Workflow Parameters**. Learn more in [Using Workflow Parameters](#) on page 859.

##### Launching tasks on Jobs

Jobs can be managed manually in the Pilot, but several actions are also possible by launching tasks.



- The [Create Job task](#) task allows to create and modify Jobs.
- The [Check Job Parameters \(Classic\)](#) task allows to check and correct barcode and ink parameters used in designs.
- The [Archive Job](#) task and the [Restore Job](#) task allow to remove Jobs, store their data on a different network place and, if needed later, restore them back, including their metadata.
- The [Relocate Job](#) task allows to move a Job's Job Folder to a different place. For example to another Container that has more disk space.

Learn more about these tasks in [Tasks you can Launch on Jobs](#) on page 583.

Like all tasks, these tasks can also be triggered by an external system. Learn more in [Integrating with External Systems](#) on page 1769.

## 7.1.2. Types of Jobs

Conceptually, we can distinguish several types of Automation Engine Jobs. This categorisation usually depends on these factors:

- What type of site are you? Does your company only do prepress or do you also produce? And if you produce, do you also re-produce items that you produced before?
- Is your Automation Engine closely integrated with your order management system? If it is, then Automation Engine best follows a similar process logic as in that system. Terms like jobs, orders, products, items, milestones etc. will need to have the same meaning.

We distinguish 3 types of Jobs:



**Attention:** The categorization of these job types does not appear in the user interface of Automation Engine. Their names are only used here to illustrate different ways of working with the tools Jobs and Products. Learn more about Products in the chapter [Products](#) on page 594.

### Type 1: A Prepress Job

The goal of a Prepress Job is to make a single one-up design print-ready. Typical steps are preflight, making print-ready and approval. The result is a file that is ready to be produced.

Some variations:

- The production can then be done in-house (in another Job, under another order number) or the print-ready file can be sent out to a company that produces.
- The resulting file can be registered as an Automation Engine Product.
- A Prepress Job can result in multiple files, but only when they belong to the same product item, for example front and back graphics. They probably also share the same approval cycle.
- At (flexo) prepress houses ('trade-shops'), the result could also be a set of plates.

The Job can be removed when the work is done.

### Type 2: A Production Job

A Production Job is a job that uses one or multiple product items for a specific production run. The product items were already approved and print-ready. The goal of this type of job is output.

A Production Job does not contain the one-up's data in its job folder, but links to one or multiple **Products**. The job folder of a Production Job typically only stores the layout files or other data that are unique to this specific production order. The product data stay in their **Product Data Zone**.

The Job can be removed when the work is done. The Products are not removed, they stay 'live' until a next Job links them in for another production run.

### Type 3: An All-In-One Job

Some customers have Jobs in which they handle both the prepress work and the output production. The one-up data is stored inside the job folder, not registered as a Product and the workflow continues within this Job with the production steps (layout, plates, send to press...). Production related data is also kept inside this job folder.

In some cases, when the output is combined with other (already existing) items, this can mean that the one-up data is copied from other (older) jobs into in this job folder.

The Job can be removed when the complete work is done.



**Attention:** In this chapter, we will describe the use of Jobs *without* the use of the Products tool.

## 7.1.3. The Jobs Views



**Note:** The view '**Inactive Jobs**' is only available for AE SaaS setups. Learn more in [AE SaaS: When your AE is in a Data Center](#) on page 1633.

### General Job Views

The Pilot and its Views were introduced in [The Pilot's Main Window](#) on page 79. We here illustrate some job-related specifics:

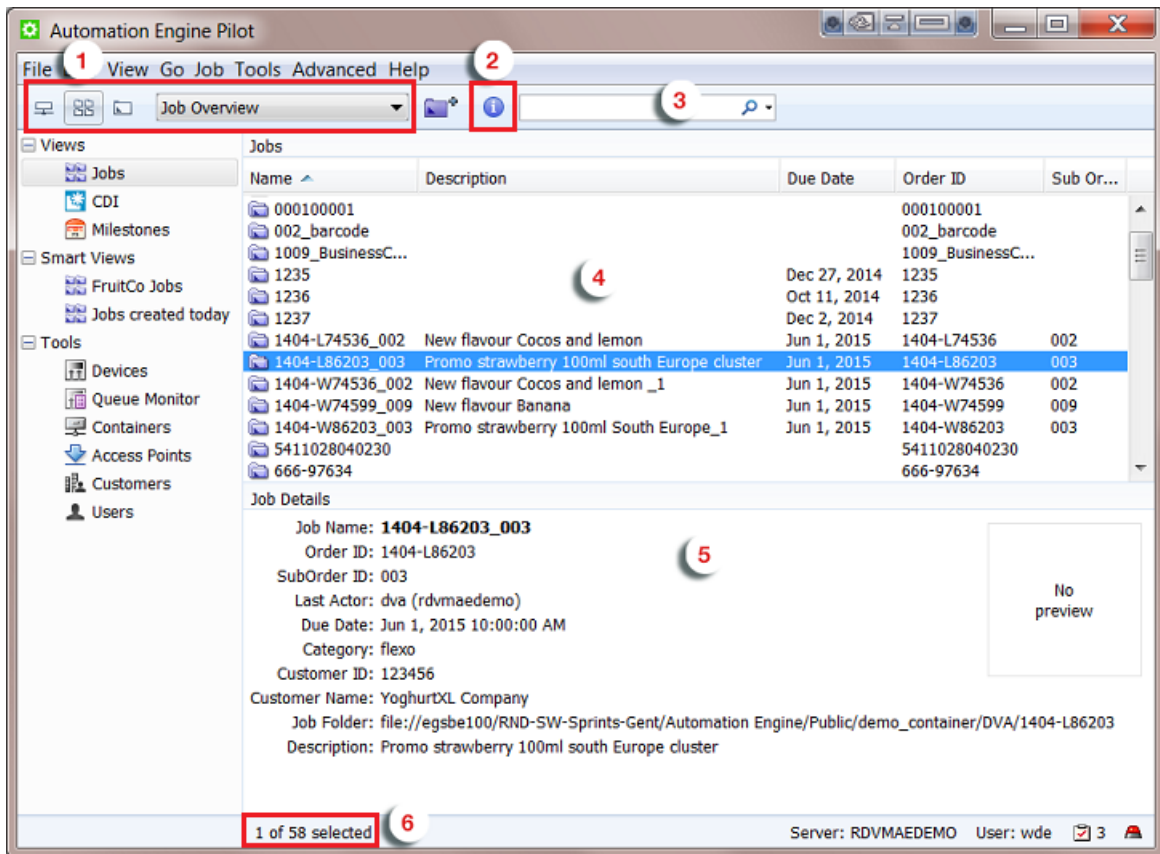

**1. Type of View.**

- The **Containers** view shows the folder structure of your Containers but will show a folder in blue when it is an active Job Folder. Double click any blue folder to select and view that job.
- The **Job Overview** shows all jobs (or a filtered list). You can combine this with *Smart Views*.
- The **Last used Job** view opens the last used job in the *job specific view*.

**2. Info.** This button opens the **Job Setup** of the selected job. Learn more in *Job Setup Parameters* on page 547.

**3. Search** input field. Learn more in *Job View Filters* on page 542.

**4. Job Overview.** Define the columns and their order in **View > Select Columns in 'Jobs'...**

**5. Job Details.** See some of the job's details. Learn more in *Job Setup Parameters* on page 547.

**6. Amount of Jobs (selected).**



**Note:** When you open the drop-down list, you can select another job that you recently used. You can set the amount of remembered jobs in **Edit > Preferences > Pilot**.

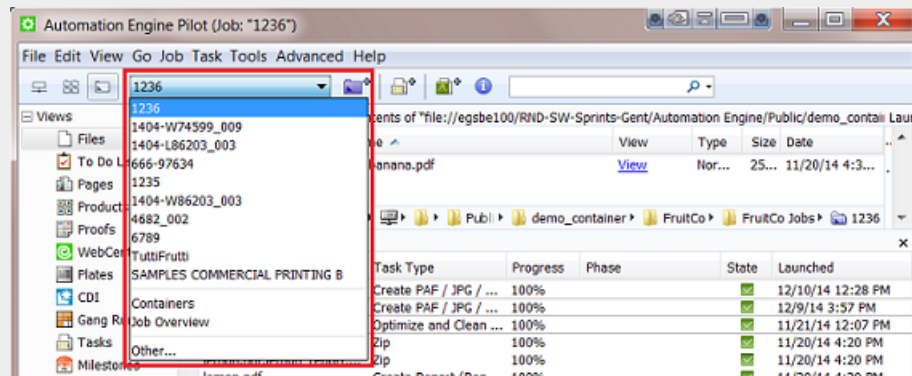

**Tip:** If you regularly switch between same views, consider using multiple view tabs (**File > New Tab**). For example:

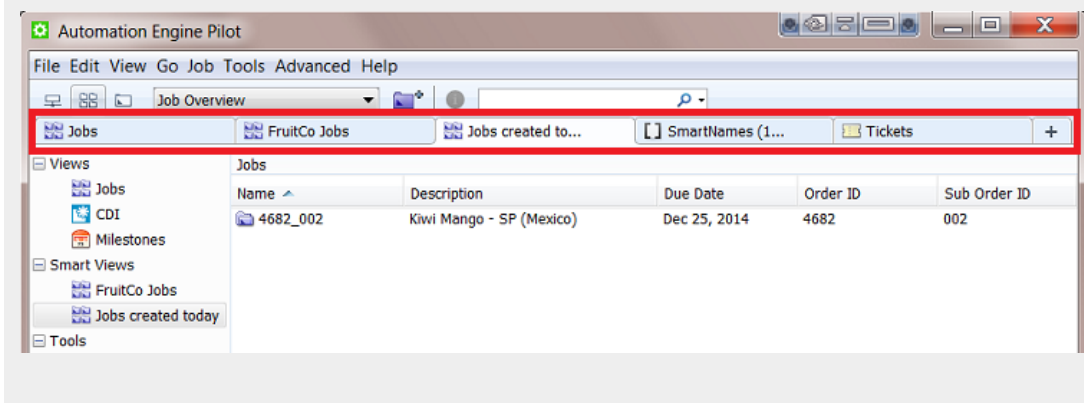

## Job View Filters

### Basic Searching

When you type in a filter in the **Search** input field, the filter will be looked for in **All** of the default attributes Order ID, Name, Project ID, Customer Job Reference.

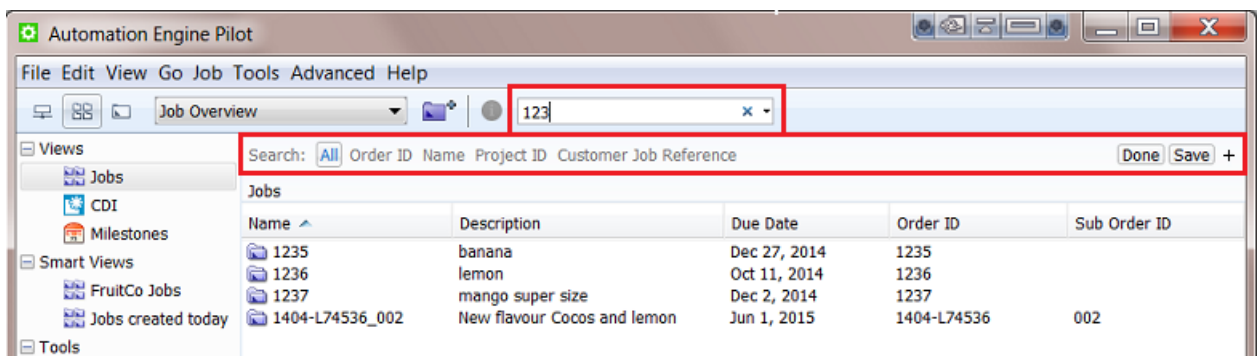



**Tip:** You can use double quotes to restrict the search. For example:

- FL 123 will list jobs that have both FL and 123 in at least one attribute.
- "FL 123" will only list jobs that have this exact string in at least one attribute.

Click **Save** to save this search. Decide if it is for all users or only yourself and if you want to add it to your views bar.

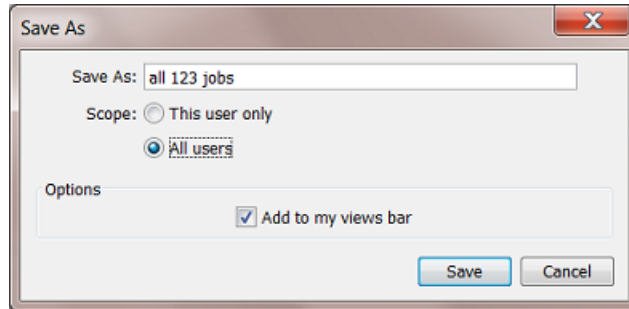

### Advanced Searching

If you want to search in other attributes, or if you want to create advanced search criteria, click on the + button. A new search criterion appears.

See how the attributes drop-down list offers many more attributes:

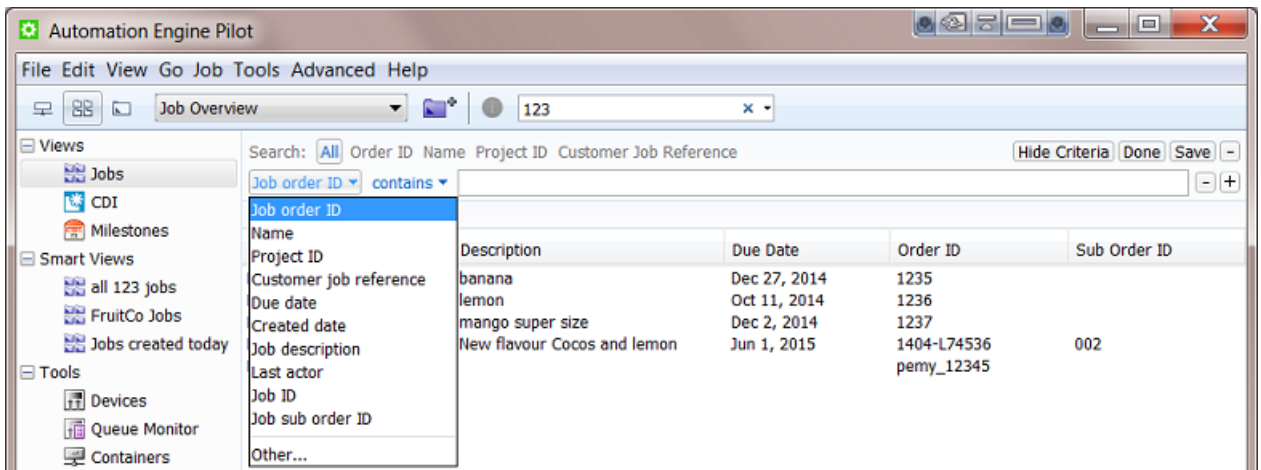

In the drop-down list, select **Other...** to add even more attributes to this list. For example **Customer name** or **Location**.

Use the + button to continue adding search criteria. For example:

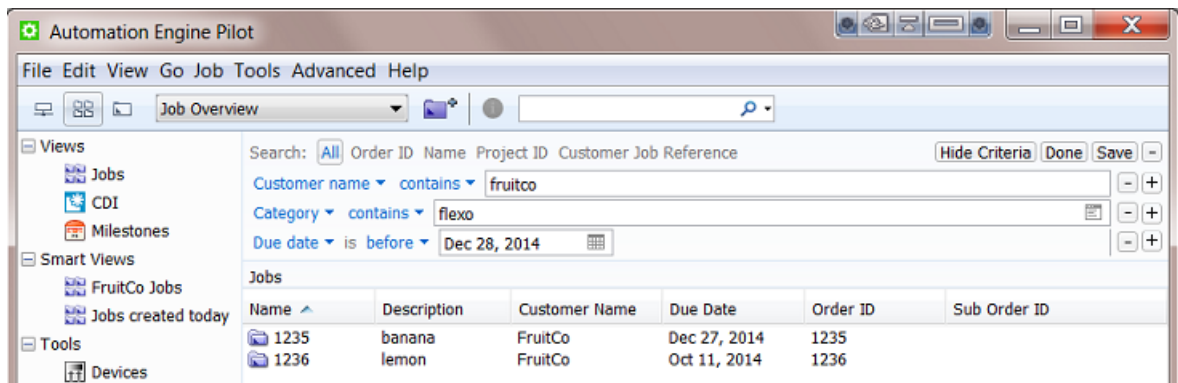

You can even add 'logical operators' to your criterion. Hold **Alt** when clicking on the **+** to start your criterion with **All**, **Any** or **None**. See this example where you are not sure which CSR handles this job order:

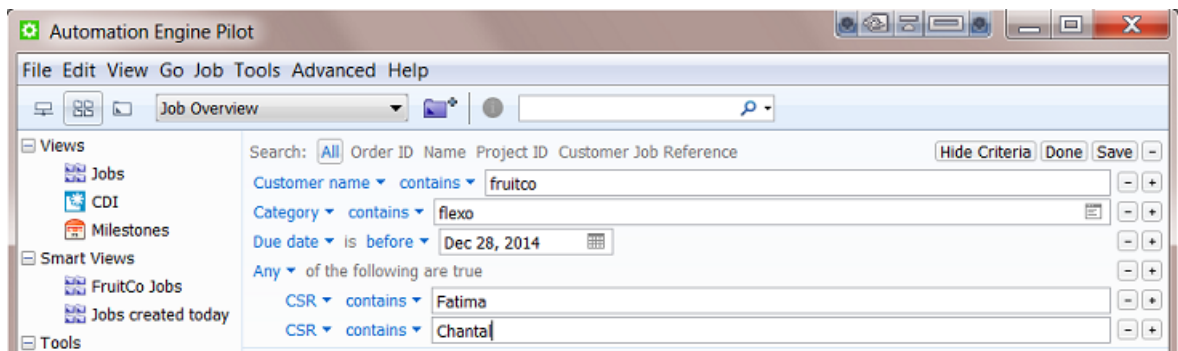

Click **Hide Criteria** to hide the lines with the criteria but still have them active.

As shown above, you can save the (set of) search criteria. You can re-use it later as a Smart View or pick it from the drop-down list in the search field:

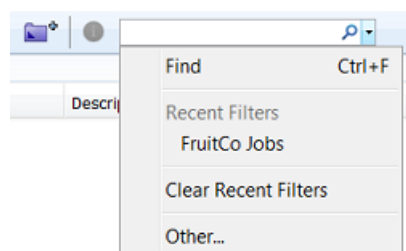

### Job Specific View

When you select a job from the drop-down list of last used jobs, or when you double click a blue job folder, the view adapts and focuses on that job.

- The Pilot top bar mentions the name of the selected job.
- The **Last Used Job** drop-down list mentions the name of the job folder.
- The Folders pane shows the (blue) job folder, its subfolders and their files.
- The Tasks pane shows the tasks that were launched in this job context.

- The list of favorite tickets also shows (blue) job tickets (saved for this job only).

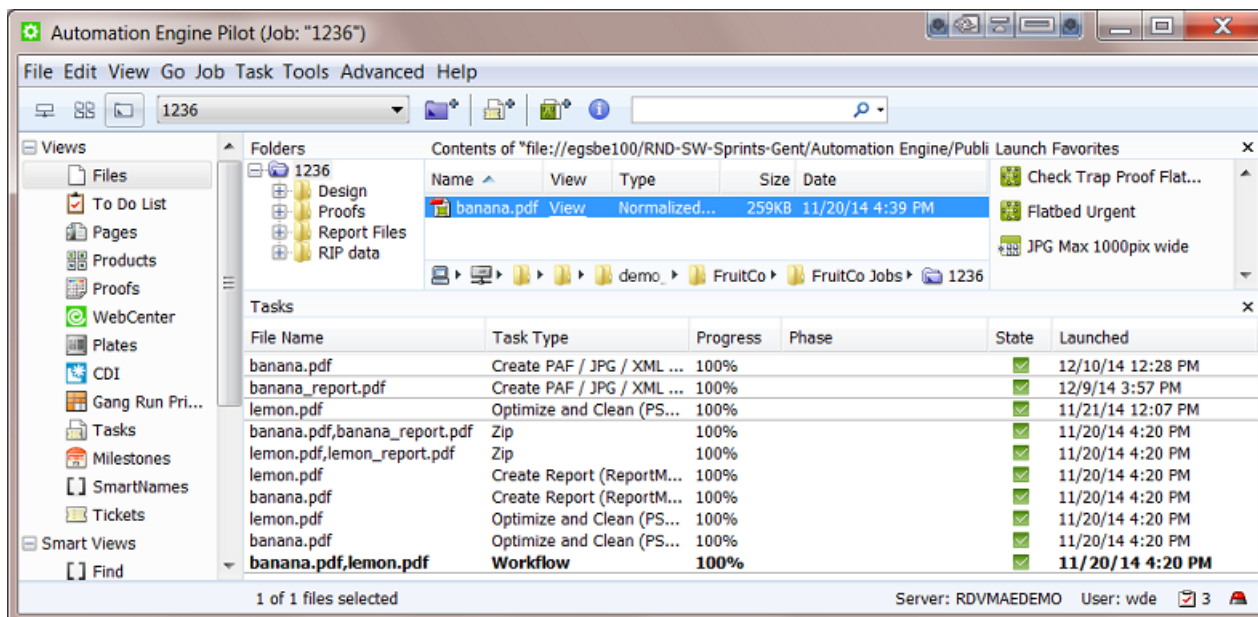

All tasks that are launched in this view will run "in this job". Job based SmartNames will now get their values from this job.

## 7.1.4. The Job Menu



**Note:** When no job is selected, some of the menu options are unavailable.

- **New Job....** Learn more in [Creating a Job](#) on page 546.
- **Go to Job.** When a job is selected in a list, use this to go to that job ('open' the job).
- **Job Setup....** This opens the Job Setup dialog of the selected job.
- **Find Job....** This opens a separate dialog to search for jobs. Learn more in [Job View Filters](#) on page 542.
- **Relocate Job.** This moves the job folder of a (live) job. Select the ticket of the **Relocate Job** task. Learn more in [Tasks you can Launch on Jobs](#) on page 583.
- **Remove Job....** This removes the open or selected job(s) from the jobs database. You will be asked to confirm and you can choose to keep the files and folders. Learn more about removing multiple jobs and re-creating them in [About Removing Jobs](#) on page 581.
- **Sharing.... Synchronize Job , Synchronize All Jobs:** These relate to functionality described in the chapter [Sharing to Collaborate with other AE servers](#) on page 1685.
- **Delete View Data....** This deletes all View Data present in the job folder. View data are stored in hidden subfolders of files that were prepared for viewing in [the Automation Engine Viewer](#). You will



be asked to confirm. You can choose to **Also unmark subfolders that are marked for Speed for Viewing**. Learn more about this feature and View Data in [Prepare for Viewer Task](#) on page 1130.

- **Manage Job Filters....** This opens a dedicated dialog to manage job filters. Learn more in [Job View Filters](#) on page 542.

## 7.2. Creating a Job

---

You can create jobs manually or they can be created automatically.

### Creating a Job Manually

To create a job, you can first select an existing folder that will become the job folder, or you can have a new job folder created while you create the job. Follow these steps:

1. In the Pilot, choose one of these methods to create a new job:
  - Go to **Job > New Job...**
  - Right-click (on an existing folder) and select **New Job...**
  - click the **Create Job** icon 
  - (Select a folder and) use **Ctrl + Alt + N** (Windows) or **Cmd + Alt + N** (Mac).
2. In the **New Job** dialog, decide if you want to **use an existing job as a template**.
  - If you don't use a template, click **OK** and fill in all the parameters in the next dialog.
  - If you want to use an existing job as a template, select it and decide which type of parameters you want to include from that job in your new job. Then click **OK**.

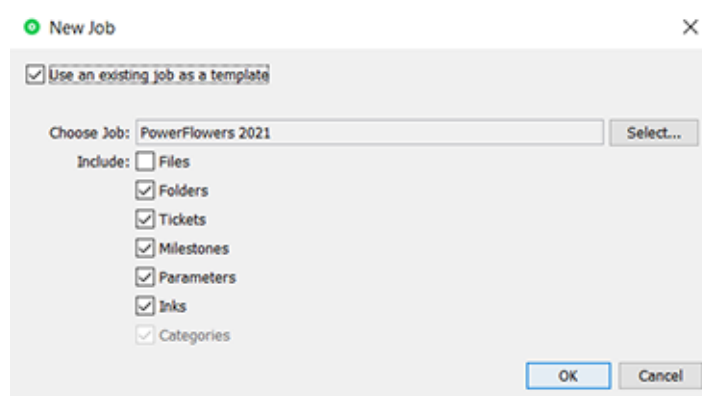

The job you use as a template could be a job that is similar to the new one (for example the 123-1emon job has many same attributes as the 234-banana job). It could also be a job that you specifically created to be used as a template (the typical 'flexibles' job for example).

The status, actions and confirmation dates of the milestones in the template job will not be added to the new job. Their due dates will be relative to the creation date of the new job. For example: you want the new job to also get the milestone 'proof ready' 2 days after it was created.



3. A dialog opens with the job setup. Now you can fill in all the parameters for the job.

If you started from an existing folder or used a template, several parameters will already be filled in.

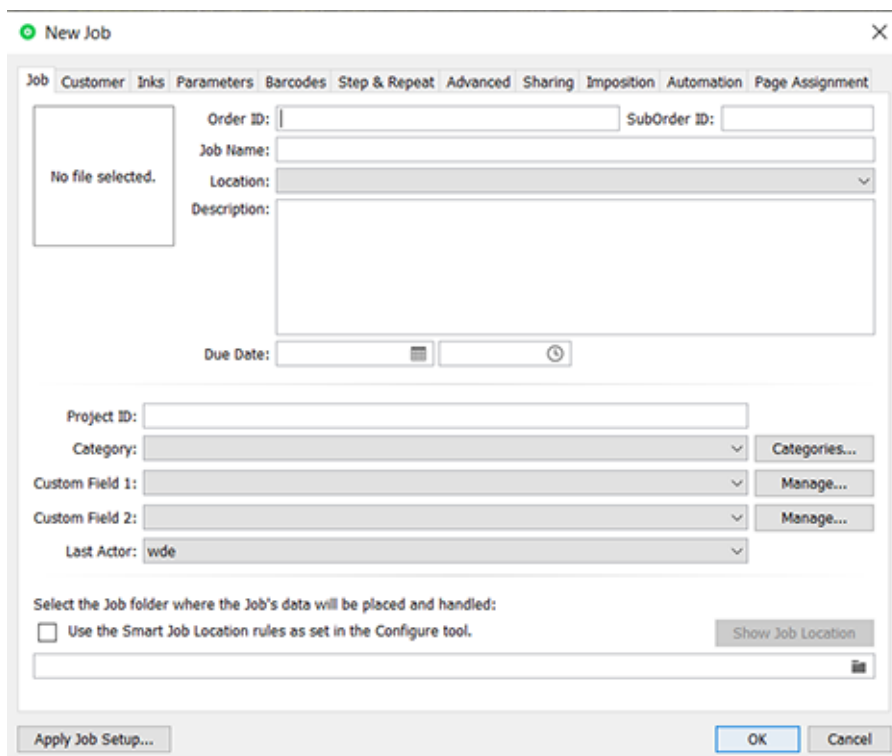

Learn more in [Job Setup Parameters](#) on page 547.

### Creating Jobs Automatically

In most cases, the Automation Engine Job originates in another system. Recreating that job manually in the Pilot is not an efficient way of working. It is strongly advised to integrate Automation Engine with that other system and so have the jobs come in automatically. This will both win you time and reduce errors.

This integration can be based on an incoming file that describes the job or could be a bi-directional link with that external system. In both cases, the [Task 'Create Job'](#) on page 1850 will create the Job in background (probably as part of a workflow task). Such an automated workflow can also update Jobs with new or changed parameters.

Learn more in [Integrating with External Systems](#) on page 1769.

## 7.3. Job Setup Parameters

You can fill in the job setup parameters while [creating a job](#), or, when you are in a job context, by going to **Job > Job Setup...**

In an existing job, you can add or modify parameters at any time, except the **Order ID** and **SubOrder ID**. Learn more in [Job tab](#) on page 548.

The parameters are spread over multiple tab sheets. The tab sheets **Automation**, **Page Assignment** and **Imposition** only appear when you are using the module for page workflows.

Most job parameters are automatically offered as Job SmartNames. Learn more in [SmartNames](#) on page 637.

The button **Apply Job Setup...** allows to copy parameters from other jobs. Select the job and define which type of parameters you want to include from that job.

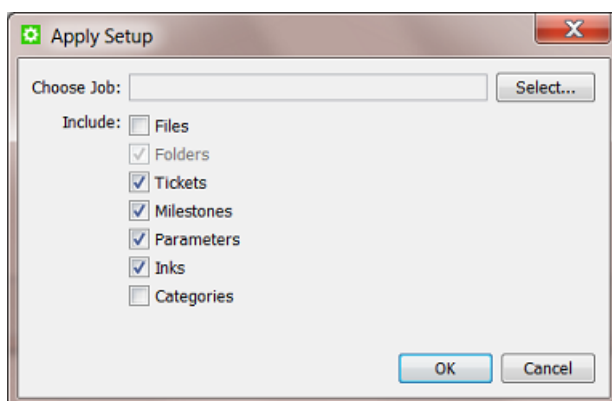

This is similar to how you can use a template job at the moment of job creation. Learn more in [Creating a Job](#) on page 546.

### 7.3.1. Job tab

The **Job** tab contains the main job order information:

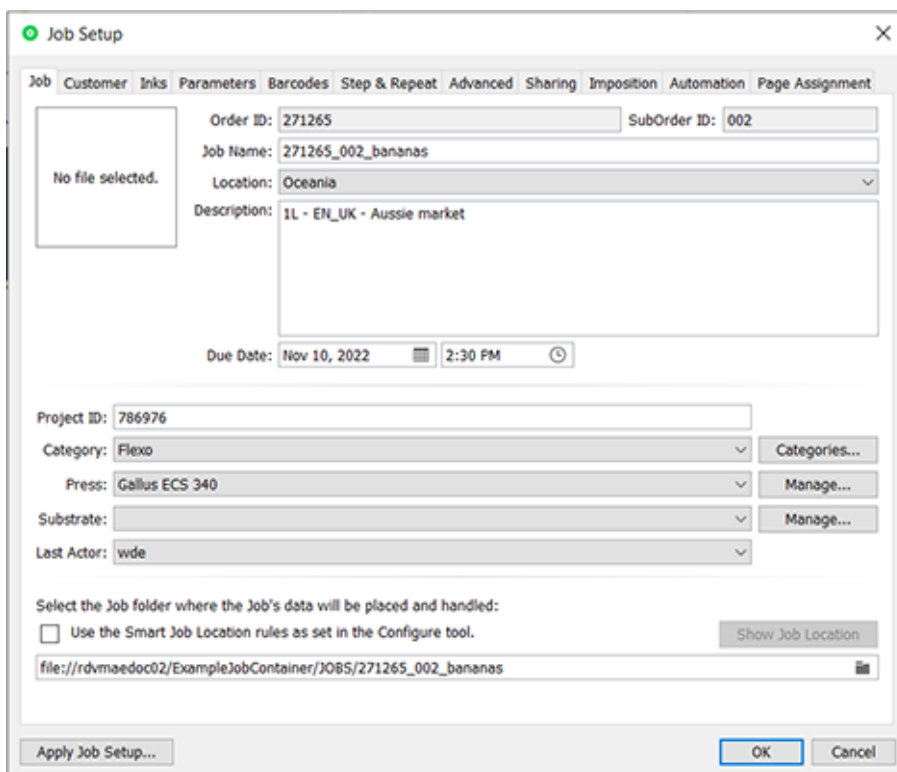

- **Thumbnail:** When there is no thumbnail yet, it will automatically be set when one of these tasks finishes successfully in this job context: [Normalize PDF File \(Classic\)](#), [Normalize PostScript / PDF / Illustrator 8.0 File \(Classic\)](#), or [Export ArtPro to Normalized PDF File \(Classic\)](#).

To set the thumbnail manually, right-click the field and select a file (that has a thumbnail embedded).

- **Order ID:** Order management systems typically define a job order by an identification number. This is a mandatory field.



**Important:** You can not change it once the job is created.

- **SubOrder ID:** A job order often also has a sub number (or text). You can leave this field blank.



**Important:** You can not change it once the job is created.



**Important:** An Automation Engine Job needs to be unique. More specifically, **the combination of Order ID and Suborder ID needs to be unique.**

- **Job Name:** This is the name that you see in the job overview mode. This is a mandatory field. If you do not enter a name here, the name will be "OrderID\_SubOrderID".



**Important:** Also the name of the job needs to be unique.



**Note:** You can change the name of a job after the job was created.



**Note:** The job name will also be proposed as name for the job folder. Learn more below.

- **Location:** A job's 'location' serves as a data filter for users in My Workspace. Learn more in [Locations](#) on page 220.
- **Description:** A short text describing the job order. By using its SmartName version, this text can for example also be picked up in a report PDF.
- **Due Date:** The due date and time for this job order. This date is used in job filtering and also in several tasks that allow choosing the **Job Due Date** as one of the choices for the task due date. For example the [Submit to Gang Run \(Classic\)](#) task and the [Publish on WebCenter](#) task.
- **Project ID:** The identification number of the project that this job order belongs to. Project numbers are typically defined by the order management system or any other external system. This parameter can be useful to find jobs that belong to a same project. This parameter can match to a project on WebCenter.
- **Category:** Choose a category from the list. Categories are often used to help you find jobs or to define the route of a workflow. Click the button **Categories...** to add new categories manually or by loading a list from an XML file.



**Note:** The format of the XML is for this use not specific. Most important to know is that only the values will be loaded to become category names, not the element names. An example:

```

<?xml version="1.0"?>
<List>
  <name1>Flexo</name1>
  <name2>Flexo combo</name2>
  <name3>Digital</name3>
</List>

```

You can add more custom categories. Two are offered in this tab sheet: **Custom Field 1** and **Custom Field 2**. You can set four more in the tab [Categorization](#). You can configure their custom names in **Configure > Jobs > Job Setup**. See an example in the above screenshot.



**Tip:** In the page about the tab [Categorization](#), you can find a table with matching names of categories, custom fields and their SmartName versions.

- **Last Actor:** The last Automation Engine user that worked with this Job (launched a task, opened a file). This is filled in automatically but you can set it manually too.
- **Job Folder:** Define the path of the job folder for this job. You can choose one of these methods:
  - Browse to an existing folder (somewhere in one of your containers).
  - Browse to the root of where you want to create the new job folder and click . By default, the **Job Name** will proposed as name for the job folder. You can change that if you want to.
  - **Use the Smart Job Location** defined in the Configure tool: When selected, the location and name of the job folder will be calculated based on a job parameter or on the default location for that customer. A preview of the folder's location and name can be asked by clicking the **Show Job Location** button. Learn more in [Smart Job Location](#) on page 217.



**Tip:** The **Browse** button can also be used to relocate an existing job folder. When you here change the path of an existing job folder, you will be asked if you want to move or copy the data to the new job folder.

### 7.3.2. Customer tab

**Customer ID:** Click **Select...** to open the **Select Customers** dialog. Choose one or add a new customer. Learn more about creating customers in [Customers](#) on page 151.

**Customer Name** and **Customer Description:** These fields will be filled out automatically after selecting a customer.

**Customer's Job Reference:** This is the term that your customer uses to refer to that job, how they named it (initially). When communicating with your customer, he will appreciate if you mention this name (as well). You can for example add this name as a SmartName to a report PDF or add it to a name of a file that you send him.

**Customer Service Representative (CSR):** Select or type the name of the person in your sales or service department who manages this customer account.

The **E-mail** address of the CSR that you selected is automatically displayed if it was used before. You can also enter the E-mail address manually.

You can click the **Contact...** button to open an E-mail message with that E-mail address in the **To** field (if an E-mail client is configured).



**Tip:** All these parameters

- can be used to filter or search for a job.
- can be entered via XML/JDF/JMF. It is strongly advised not to re-enter these admin data manually. Learn more on how this can be done in [Integrating with External Systems](#) on page 1769.
- exist as **System SmartNames**.

### 7.3.3. Inks tab

This tab allows to store ink specifications for this job.

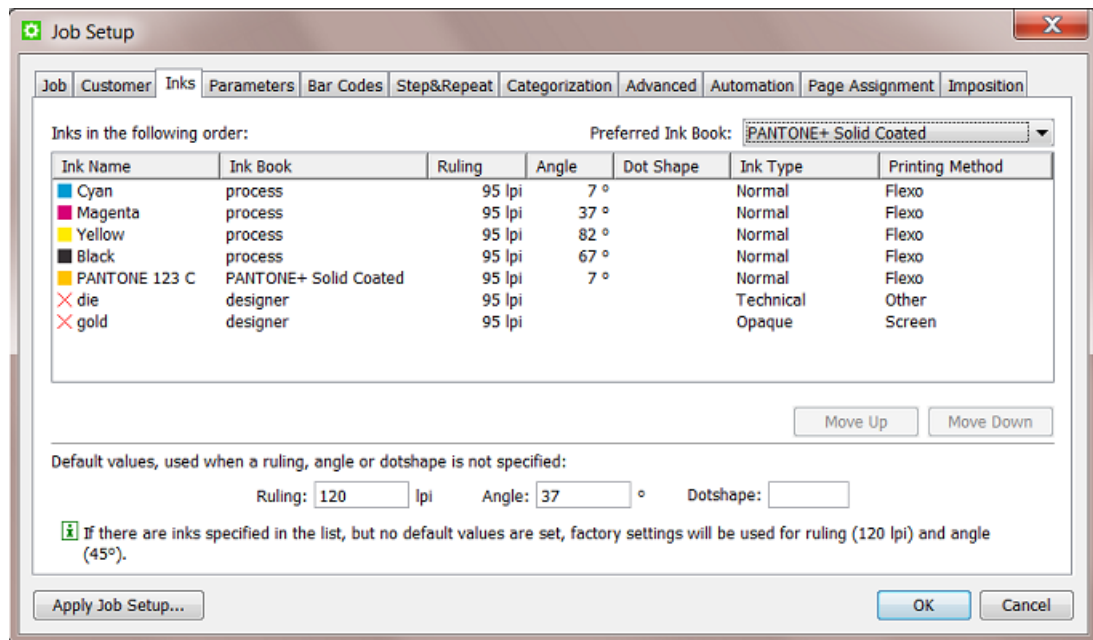

What you enter here serves as a *minimal* requirement for this job. This means that you can for example only enter the angles for a specific set of ink names and leave all other fields or columns blank.

As with most tab sheets, you can enter this data manually, copy these parameters from another job (see the button **Apply Job Setup...**) or, when using the [Task 'Create Job'](#) on page 1850, get them from an XML file.

### Use cases

Job ink parameters can be used in these cases:

- When you import design files, the task [Normalize PostScript / PDF / Illustrator 8.0 File \(Classic\)](#) on page 385 offers to enforce these job ink parameters in the output file.
- In PackEdge or ArtPro, when you open a file that is located in a job folder, the editor will check if the file's inks match the job ink parameters and show a warning when they don't. You can also use the **Load Job Parameters** feature in the editor's **Inks** dialog to enforce the job ink parameters.
- When you use the task [Check Job Parameters \(Classic\)](#), you can check and or modify the attributes of the inks in the file.
- In page workflows, when you use the **Variant Setup** in the [Imposition tab](#), the job's inks will be used.



**Important:** When working with ArtPro+ and PDF+ (PDF native) files (where no normalization is done), there is no equivalent for these features.



**Note:** A job can only have one set of ink parameters.

**Preferred Ink Book:** When you then type an ink name in the table, Automation Engine first searches this ink in your preferred ink book. For example, if you type 154 as ink name, and your preferred ink book is `Pantone Colors Uncoated`, Automation Engine will automatically suggest the ink `PANTONE 154 Uncoated`.

**Printing Method:** You can set a printing method per ink. The list shows those defined in the [Configure tool](#).

These are typical examples of how to make use of a **Printing Method**:

- In your **Imaging Engine** (RIP) task for a flexo device, you select only the inks of printing method 'flexo'.
- You make a special ReportMaker PDF that focusses on the 'ink' used for embossing. In your workflow, you use the [Extract Inks \(Classic\)](#) task to select the wanted ink type before you start the ReportMaker (Classic) task.

#### Some tips on editing the ink list

- To start, click in the empty canvas under the column **Ink Name** and type in an ink name. For example 'C'.
- **Ruling** uses the unit as defined in **Edit > Preferences... > Units**.
- To change all fields in a column with a same value, double click the column header (valid for **Ruling, Angle** or **Dot Shape**).
- You can define specify ruling, angle and dot shape per ink name or you can set **Default values** by using the fields at the bottom of the tab sheet to specify them for *all* such fields (when still empty).

### 7.3.4. Parameters tab

This tab allows to store two types of job parameters:

- **General** custom job parameters, with a name and value that you decide. They will also appear as a SmartName.
- **FlexRip/Proof tasks** parameters. This is an older technology that allows enforcing job parameters into the FlexRip or FlexProof task tickets. Learn more in [FlexRip/Proof Job Parameters](#) on page 555.



**Note:** With Imaging Engine, this concept is replaced by the use of SmartNames.

These job parameters can be created in 3 ways:

- Manually. Learn more in [Creating and Modifying a Custom Job Parameter](#) on page 553.
- By loading values from an XML file. Learn more in [Loading Job Parameters from an XML File](#) on page 554.
- By using the **Create Job** task, where you use the (XML) input from an external system. Learn more in [Task 'Create Job'](#) on page 1850.

#### Creating and Modifying a Custom Job Parameter

Use the buttons **Add...**, **Modify...** and **Remove** to manage your custom parameters manually.

Follow these steps to add a custom job parameter:

1. Click **Add...** to open the **Add Job Parameter** dialog.
2. Choose the **Scope** 'General'. Learn more about the other Scopes in [FlexRip/Proof Job Parameters](#) on page 555.
3. Type in the **Name** and **Value** and click **OK**.

The SmartName version will be created automatically. To easily recognize which SmartNames are job specific, their name starts with [jp. ].

### Loading Job Parameters from an XML File

If you have an XML file that contains the custom job parameters, you can create them automatically by loading them into your job setup:

This XML requires this basic structure ; within a root node, a simple list of pairs of elements and their value:

```
<root>
<parameter1>xxx</parameter1>
<parameter2>yyy</parameter2>
</root>
```

An example:

```
<jobparams>
<profile>CMYK</profile>
<proofing>e-mail</proofing>
<reportcard>yes</reportcard>
</jobparams>
```

1. In the Job Setup tab **Parameters**, click **Load...**
2. In the **Load Job Parameters from XML** dialog, click **Browse** and browse to your XML file.
3. Click **OK**. You now have a custom parameter for all value pairs the XML contains from the root node. All elements and their values will be imported.  
An example result after loading such an XML file:

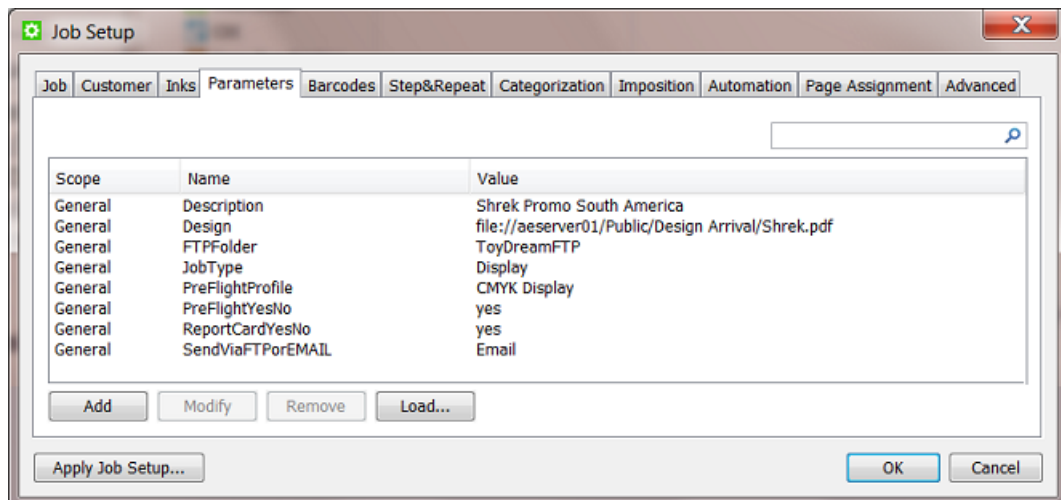

**Tip:** If you have long parameter lists, you can use the search field to help you filter them. The value is checked in Scope, Name and Value.

Job parameters also become SmartNames. See the automatically created SmartNames of these custom job parameters (for this job '1236'):



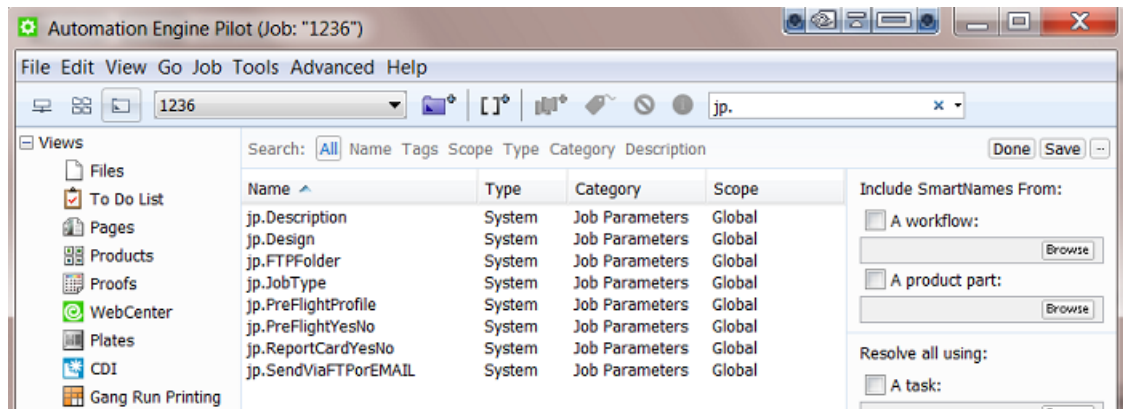

Learn more about using SmartNames in [SmartNames](#) on page 637.

### FlexRip/Proof Job Parameters



**Note:** With Imaging Engine, this concept is replaced by the use of SmartNames.

#### Creating Job Parameters for FlexRip or FlexProof

1. Click **Add...** to open the **Add Job Parameter** dialog.
2. Choose the **Scope** of a specific task type of FlexRip or FlexProof.
3. Check the parameters that you want to enforce during RIP'ing and define their value. For example:

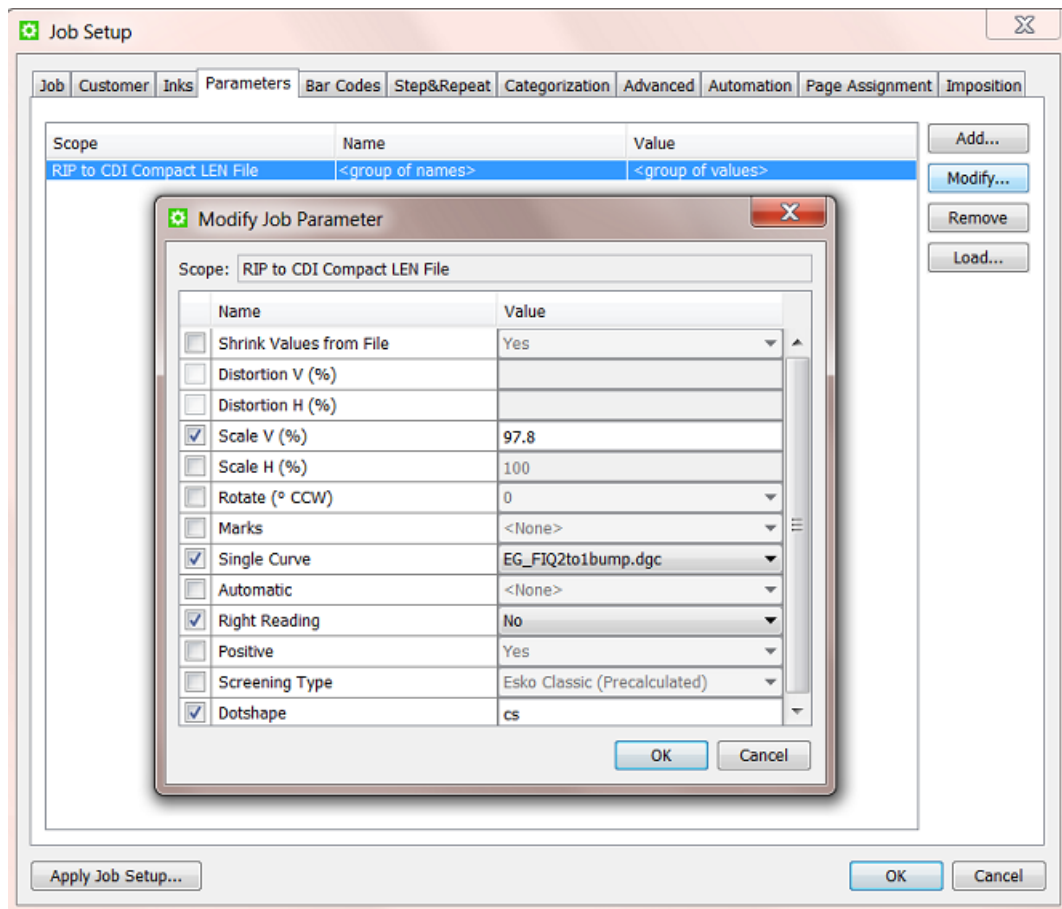

Click **OK**. The job parameters for this type of FlexRip/Proof will be added as one line.

### Using Job Parameters for FlexRip or FlexProof

When you now select a file in that job and open a task ticket for that particular FlexRip/Proof, you will see fields that are marked by an orange icon . These are fields that are overruled by the job parameters.

For example:

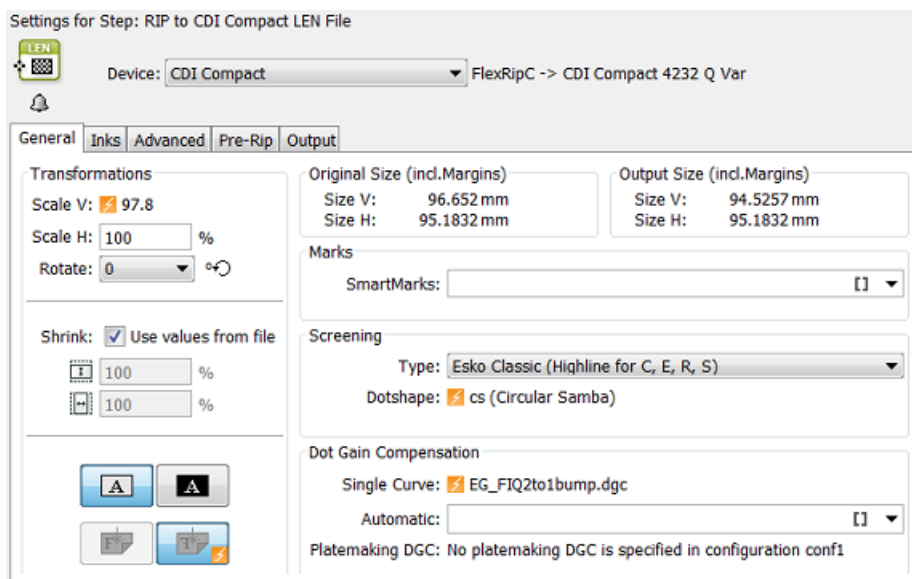

### 7.3.5. Barcodes tab

#### Concept

In the **Barcodes** tab you can create parameters for multiple barcodes of different types.



**Tip:** One file can for example have a retail barcode and also a general purpose barcode that will be used for a filling station.

As with most tab sheets, you can enter this data manually or get them from an XML file when using the [Task 'Create Job'](#) on page 1850.



**Tip:** When selecting a barcode, the specified parameters are shown in the **Details** area.

#### Enforcing barcode parameters

Similar to the [Inks tab](#) on page 551, these parameters can be used to enforce their parameters into the barcodes of the job files that you opened in PackEdge or ArtPro. Also here, the [Check Job Parameter task](#) can be used to check or correct the barcodes in the files versus the parameters you specify here.

See this example where the job parameters are enforced  into the barcode in PackEdge:

In AE Job Setup

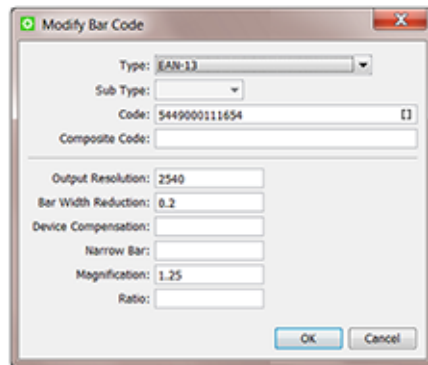

In PackEdge

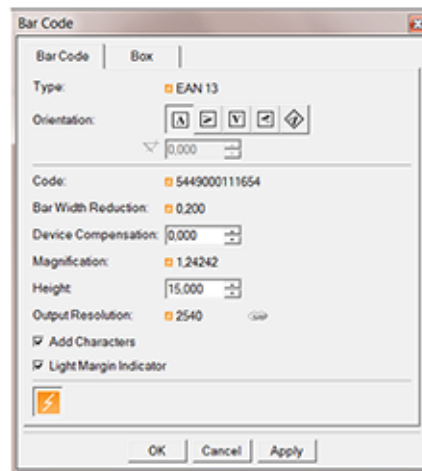

See this example where the job parameters are enforced into the barcode in ArtPro+:

**2. ArtPro+**  
Open file from this AE Job  
Create Barcode

**1. Automation Engine**  
Job Setup

We now briefly describe the available parameters.

Learn more details in the [documentation of your Esko editor](#) (DeskPack, ArtPro+ or classic editor PackEdge).

### Type

Selecting a type of barcode is mandatory. It also defines the other fields and disables those that are not relevant for this type.



**Note:** When you define more than one barcode, the checking mechanism with the editors and the *Check Job Parameter (Classic)* task will recognize the type of barcode and check accordingly.

### Sub Type

Some barcode types offer sub types. For example a **Data matrix** code.

### Symbol Size

Some barcode types allow to define a symbol size. For example **QR** and **Data matrix** codes.

This size defines the amount of cells in a barcode. The symbol size will automatically increase when entering too much data for the current symbol size.

### Code

The validity of the code is not checked here in this dialog. This is done in the editors.

### Composite Code

A composite code is a 2D symbol placed on top of a GS1 barcode, that encodes extra information (batch number, expiration date, ...).

### Output Resolution

Enter the resolution (in ppi) that you will use to RIP this barcode. This parameter helps preventing unwanted levels of rounding in the bar width.

### Bar Width Reduction (BWR)

Use this parameter to adjust the width of the barcode bars, in order to compensate for ink bleeding when printing on your substrate.

Your printer or customer will usually provide you with the value to use. For example if your printer tells you that the line width will increase by 0.01 mm, you should use a **Bar Width Reduction** value of 0.01 mm.



**Important:** This field expects a value in millimeters (mm).



**Important:** If you use a comma as a decimal symbol, it will be replaced by a dot.



**Tip:** You can enter a negative value if you want to print thicker and not thinner bars.

### Device Compensation

Use this if your printer gave you a separate device bleed value. This parameter adjusts the bar's width to compensate for bleed caused by the plate or film making process.



**Important:** This field expects a value in millimeters (mm).



**Note:** If you use both a **Bar Width Reduction** and a **Device Compensation** value, the software will add them together to adjust the bar's width.



**Tip:** You can enter a negative value if you want to print thicker and not thinner bars.

### Narrow Bar

This parameter determines the width of the narrowest bar of your barcode (and affects the width of your barcode proportionally). For GS1 barcodes, this affects the size (height and width) of your barcode proportionally.

### Cell Size

Some barcode types allow to define the size of a single black or white square. size. For example the types **Aztec** and various **QR** and **Data matrix** codes.

### Magnification

Use this parameter to increase or decrease the barcode size proportionally. For example: enter 1.25 for a magnification of 125%.



**Important:** The value needs to be between 80% and 200%.

### Ratio

The **Ratio** is the factor between the width of the narrowest bar and the width of the widest bar in your barcode. For example, enter 3 if you want your widest bar to be three times as wide as your narrowest bar.

## 7.3.6. Step & Repeat tab

### Specific JDF

This tab with Step & Repeat parameters is only useful in a workflow where you receive a JDF from an external system that describes the Step & Repeat via "JDF for Stripping for Packaging". Such a JDF will not only create the job but also store those specific Step & Repeat parameters in this tab.

These parameters also become job parameter SmartNames and can so be picked up by Step & Repeat tasks. They will appear as `[jp.steprepeat. ]`.



**Note:** The task [Import JDF Step & Repeat \(Classic\)](#) on page 360 uses the JDF itself as input. In that case the values shown here are just informational and the task does not use SmartNames.

### Also via XML?

Step & Repeat specifications can also come from external systems via an XML file or database queries or HTTP calls. In such cases, these parameters do **not** end up in this tab sheet and they also become other types of SmartNames. Learn more about this in [Integrating with External Systems](#) on page 1769.

### Manual entry

You can also enter values manually here but that usage is not different than when you would add them in the custom **Parameters** tab sheet.

## 7.3.7. Categorization tab



**Attention:** This tab only appears if you created custom categories in the Configure tool (learn more below).

The **Categorization** tab allows you to manage up to **four extra** custom Job Categories (you already have three category fields in the **Job** tab).

You can use these custom categories as extra ways to search jobs. And you can also use their SmartNames in task tickets.

### Creating and Modifying a Custom Category

Go to **Tools > Configure > Jobs > Job Setup** and type the name of custom category.

### Managing their Values

To manage the list of values you can choose for each category, click the corresponding **Manage...** button, and add or remove items to the list. In this dialog, you can also load lists of items from an XML file by clicking **Load...**

### Overview of Custom Categories and their SmartNames

Because there is already 1 *standard Job Category*, the number of your custom categories will be 1 higher. See this overview:

**Table: Names of custom Categories**

Name of Job setup tab	Name of category in Job setup	Custom field number	Name of SmartName
Job	"Category"	/	Job Category
Job	name you gave	custom field 1	Job Category 2
Job	name you gave	custom field 2	Job Category 3
Categorization	name you gave	custom field 3	Job Category 4
Categorization	name you gave	custom field 4	Job Category 5
Categorization	name you gave	custom field 5	Job Category 6

Name of Job setup tab	Name of category in Job setup	Custom field number	Name of SmartName
Categorization	name you gave	custom field 6	Job Category 7

### 7.3.8. Advanced tab

This tab sheet offers a feature to automatically start a task or workflow when you create or update a job that uses this job as a template.



**Important:** This is an old feature. Learn below about alternative ways to reach the same goal.

If you wish to use this, check the toggle and select the **Task Type** and **Ticket Name**.

#### When is a Job updated?

A job is updated in these cases:

- When the JDF that created the job is sent again to Automation Engine. Learn more about JDF in [Integrating with External Systems](#) on page 1769.
- When a **Create Job** task is launched again on the same job.

#### When is this feature useful?

This feature can be useful when you have jobs that are created automatically via JDF without the automatic launching of tasks at that moment. Your JDF can then specify that a job needs to be used as a template. And that template job can have this parameter active to launch a task.

#### Alternative methods

There are other ways to launch a workflow in a job that was just created or updated.

The task [Task 'Create Job'](#) on page 1850

- can be part of a workflow, so right after this step where the job is created your workflow continues with more steps.
- can be started automatically by an Access Point. Learn more in [Access Points](#) on page 1777.
- also has a tab sheet with this same feature. Learn more in [Task 'Create Job'](#) on page 1850.

### 7.3.9. Sharing tab

This tab shows information about the sharing of files in this job with other Automation Engine servers within your company.



Learn more in the chapter [Sharing to Collaborate with other AE servers](#) on page 1685.

### 7.3.10. Automation tab (Page workflow)



**Note:** This tab is only offered in page workflows. Learn about these classic tools in the dedicated AE Commercial Print manual available for [Automation Engine version 18.1](#) or older.

The **Automation** tab offers tools to automate your page workflow. When a certain job related event happens, a specific task can be launched automatically, which then can lead to a next status in the workflow.

You can do this for **Normalization**, **Proofing** and **Exposing**.

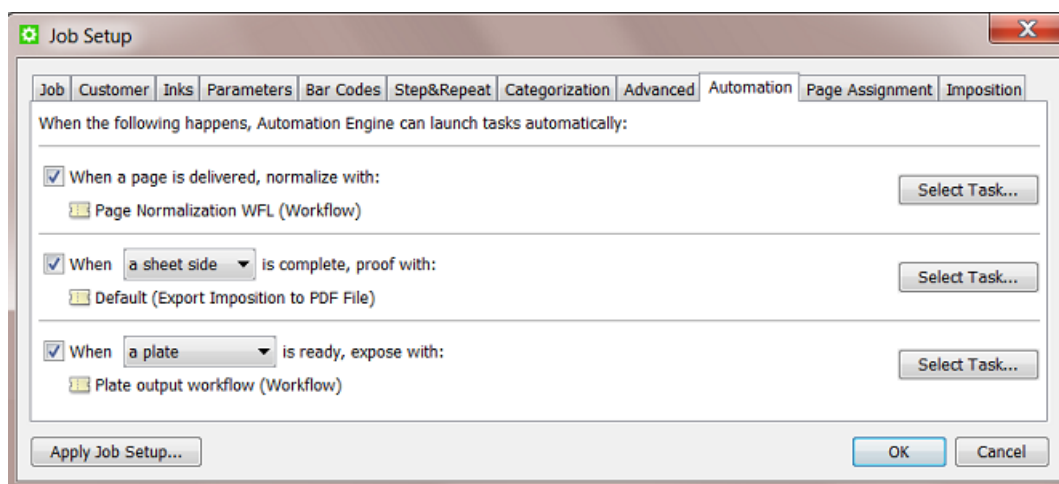

- Choose how you want to normalize the file **when a page is delivered**. Select a single task ticket or a workflow ticket.
- Choose when you want to launch a **proofing** output task: when **a sheet side**, **a variant** or **an imposition** is complete. Select a task ticket.
- Choose when to **expose** your job: when **a plate**, **a separation set** or **an imposition** is ready (complete and approved if required). Select a single task ticket or a workflow ticket.

### 7.3.11. Page Assignment tab (Page workflow)



**Note:** This tab is only offered in page workflows. Learn about these classic tools in the dedicated AE Commercial Print manual available for [Automation Engine version 18.1](#) or older.

This tab offers settings to automate the assigning of incoming PDF files to Page slots.

## 7.3.12. Imposition tab (Page workflow)



**Note:** This tab is only offered in page workflows. Learn about these classic tools in the dedicated AE Commercial Print manual available for [Automation Engine version 18.1](#) or older.

- **Variant Setup**

When working with variants, this allows you to select the correct use case and variant separation from the list. Learn more in the AE Commercial Print manual, in 'Working with Plates' # 'Variant Setup'.

- **Output prerequisites**

These settings allow you to decide when a separation can be considered as being ready.

- **When no page is rejected:** This is called "implicit approval". The plate status in the **Plates View** will indicate 'ready for ripping' if all the pages of the plate are assigned and if no page is rejected. When a page for that plate is unassigned or rejected, the output task on a plate will fail.
- **When all pages are approved:** This is called "explicit approval", it is more strict than "implicit approval". The plate status in the **Plates View** will only indicate 'ready for ripping' if all the pages of the plate are approved. When not all the pages on that plate are approved, the output task on a plate will fail.

Learn more in the page on 'Task status information'.

Learn more about the Plates tool in the section 'Working with Plates' of the above mentioned user manual.

## 7.4. About Job Folder Location

---

### 7.4.1. General Note on Data Structure

#### Automation Engine allows you to choose your own data structure

As mentioned in the page [Containers \(an Introduction\)](#), Automation Engine will work with the data structure you have.



**Note:** In an AE SaaS setup, the AE Containers are not inside your LAN network. Learn more in the chapter [AE SaaS: When your AE is in a Data Center](#) on page 1633.

This freedom also brings requests for advice on what data structure would best serve your specific needs. The more you learn about the available tools (Jobs, Products, SmartNames, Workflow Parameters, etc.) the more you will learn what is (no longer) important in that data structure.

#### Historical View on Data Structure

Before there were workflow automation servers like Automation Engine, prepress managers built up their own logic in the prepress data structure. Prepress operators browsed many folders in the network to open a file in their workstation editor and then saved it again, often with a changed name.

Very typical was the habit to write information about the files into both their name and their location. For example: a final version was named "name\_final.pdf" or written in a folder "Final". Or a file was named "lemon\_c\_m\_y\_k\_pms123.pdf". Or when the job was ready to be archived they moved the whole job folder to a share "For Archive".

Then came workflow automation servers like Automation Engine where the information is (automatically) stored in database fields. And the user can see information via a dedicated interface in an AE client. You can for example list all jobs of the category "NON-FOOD" or you can use the "i" button to see the PDF's inks (XMP metadata).

Does this mean that the data structure and the file naming is less important than before? No, actually the opposite is true.

### Why is it still Advised to have a Logical Data Structure?

There are two main reasons why a logical data structure is more important than ever:

- **For the people that do not use the Pilot or a browser workspace.**

Are there non-prepress users looking directly at your prepress data structure? If those people are not using an AE client, they will still want to get information from the location or from the name (like in the 'old days').



**Note:** We advise to check if those colleagues will not prefer to use an AE client and benefit from that information-rich view. Remember you can use User Access Rights to limit their access. And they could even benefit from using the **Viewer**.

- **For external systems** that look at, use or deliver the data.

What other systems are looking at your data structure or at files that come from there? What systems send you data into that data structure?

The integration of Automation Engine with many other systems is the main reason that your data more than ever needs to be well structured and named. Learn more in [Integrating with External Systems](#) on page 1769.

For these reasons we advise to:

- Investigate thoroughly what data structure will serve your needs and those of the system(s) you (will) integrate with. This includes avoiding copied data.
- Use all the tools that can automate the creation of those folders and file names (templates, SmartNames, Smart Job Location etc.).

## 7.4.2. FAQs on Job Folder Location

### Can I Move a Job Folder?

As explained in [The Job Concept](#) on page 538, a job is a temporary object. But even during its short life time, it can happen that you want to move the physical data to another place in the network.

In this case, it is very important that you use one of the tools in Automation Engine to do this. If you use the OS tools (Windows Explorer, Mac Finder etc.), Automation Engine will not be aware of this move and its database field for the job folder will still refer to the old path.

You can relocate a job folder

- manually, one by one. By using the **browse** button in the *Job tab* on page 548 of the job setup. You will have the choice to move or copy the folder.
- by using the *Relocate Job* task. You can launch this task on multiple jobs (for example on a smart filtered selection).

### Can I Rename a Job Folder?

To rename a job folder you can use the same manual relocation tool as mentioned above.

1. In the **Job** tab of the job setup, in the field with the job folder path, change the name of the folder.
2. Click **OK**. The resulting dialog offers a choice on what to do with the original folder and files.

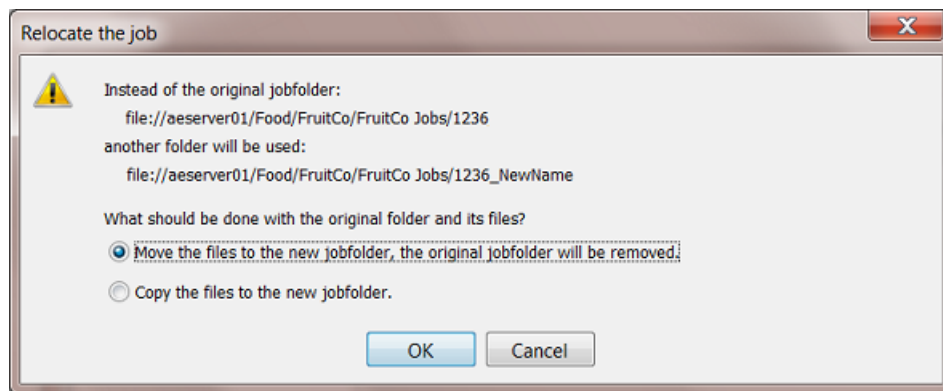

3. Make your choice and click **OK**.

### What happens when I Remove a Job Folder from a live Job ?

When Automation Engine can not access the job folder of a job that you are trying to open or use, a warning dialog will mention "**Could not retrieve the list of files**". The Pilot will show the job folder in yellow.

This is the same warning that you will get when there is network problem and Automation Engine can for example not access a complete **Container**.

When Automation Engine can again access that folder again, with the place and name it was expecting, the job folder will again be shown in blue and ready for use.



**Note:** In the Configure tool, there is a feature that allows to remove all "dangling jobs" (jobs that have no more link to their job folder). Learn more [here](#).

## 7.4.3. Good Practices regarding Job Folder Location

Creating all your job folders under 1 same root folder can result in a slow Automation Engine Pilot and even slow tasks. We advise not to do this.

Here is an example setup that certainly causes too many subfolders in one same folder:

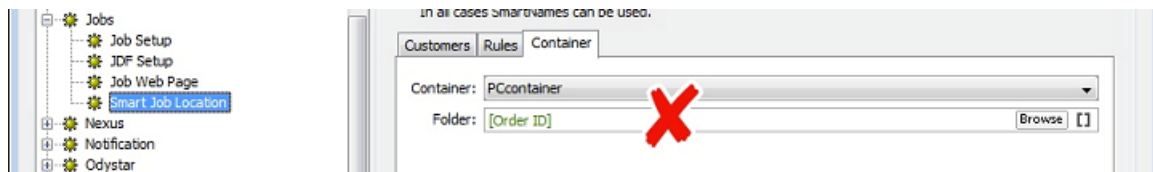

To keep your system healthy, it is good practice to use subfolders in your data structure.

Here is some advise on what logic you could use to decide that data structure:

### About using Subfolders per Customer Name

We do not advise this, mainly because customers tend to change their names. It looks like a good idea at first, but Esko has seen many customers migrating away from this structure.

### About using Subfolders per Customer ID

We do not advise this. It is true that using a customer ID is more stable, but it also has some disadvantages:

- That customer ID number is often meaningless to the Esko users.
- Because legal regulations may require your company to keep track of order history, it is possible that old customers may not be deleted in the business system. That is why, when your customer changes his name, some business systems then change the ID anyway.
- Another reason to not base your folders on customer ID is that customer companies also merge.

These reasons show that we again face the same issues as when we use the customer's name.

### About Using Subfolders per Type of Job Order

We do advise to base a data structure on types of jobs.

If you have prepress orders (creating and getting a one-up print ready) and production orders (outputting existing approved data), then structure them in separate folders or even different **Containers**.

Or you can use the product or production type: labels, carton, digital, flexo, offset etc. A typical way to set this up is by using the SmartName of a Job (custom) Category.

### About Using Subfolders per Order Range

We do advise to create a data structure where you split folders based on the job's Order ID.

For example: all jobs in the 1000 range in one folder, all jobs in the 2000 range in the next folder, etc. This is a straight forward structure that will not allow more than 1000 subfolders in one folder. Use [String Extract SmartNames](#) on page 671 to set this up.

This is considered to be the best practice.

For example:

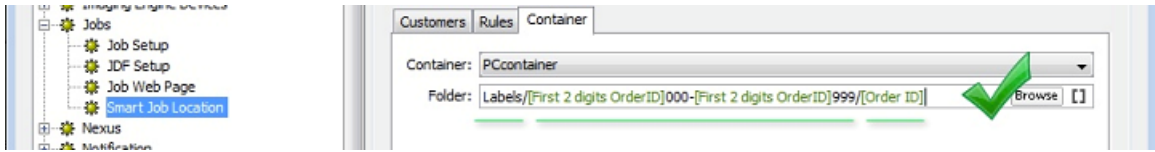

**Note:** All these principles also apply to folders where you store Products (Product Data Zone). Learn more in the dedicated chapter on [Products](#) on page 594.

## 7.5. Uploading Files to Jobs

There are many ways to upload files to a job folder's folder structure:

- Manually:
  - using the Pilot
    - drag and drop files or folders from outside the Pilot onto a job (sub)folder in the Pilot. Or use copy/paste shortcuts.
    - right-click a job (sub)folder and choose **Upload Files....** Learn more [here](#).
    - right-click a job (sub)folder and choose **Upload Files from FTP Site....** Learn more [here](#).
  - using My Workspace (browser client). Learn more in [Workspace 'My Workspace'](#) on page 891.
  - using Shuttle, as start of a workflow in this job. Learn more in [Working with Shuttle](#) on page 875.
- Automatically:
  - from [Access Points](#) on page 1777. Any of the 5 types of Access Points can upload data to a job (sub)folder (and launch a workflow). The Folder Access Point can also be a subfolder of the job folder. Learn more in [Integrating with External Systems](#) on page 1769.
  - using the [Task 'Download WebCenter Document'](#) on page 1756. When your Automation Engine is connected to a WebCenter, this task logs on to WebCenter and downloads documents from a specified WebCenter project. Learn more in [Integrating with WebCenter](#) on page 1741.
  - from WebCenter,
    - by synchronizing the WebCenter project with an Automation Engine job. When a WebCenter project has a **workflow connection** with an Automation Engine job, documents can be copied to that job when synchronizing. Set this up in the **Configure** page of the WebCenter project.
    - by using WebCenter's **Sync Workflow** task in a WebCenter workflow. Learn more in the [WebCenter documentation](#).

## 7.6. Milestones: Tracking Job Status

### 7.6.1. Concept

Milestones represent important moments in the life of an Automation Engine job. Each job has at least one Milestone: the moment it was created. You can add Milestones, predefined ones or custom ones. Each Milestone has a due date and several other attributes (see below). The goal of a Milestone is that it gets confirmed.



**Note:** The **Job Due Date** that you set in the job setup is not automatically created as a Milestone.

A Milestone has these attributes:

- a **Name**. For example "Approved".
- a **Due Date**. This is the time that this Milestone is expected to be confirmed. It could represent when deliverables are expected (plates, print production, shipping, invoicing). Or it could stand for the time an action is expected to be finished, for example "Approved" in 3 days.
- a status. Users can decide on the status **Confirmed** or not (still "pending").
- a set of **Actions**. You can optionally attach Actions that need to be done to get that Milestone confirmed.
- a **Responsible** user.

Milestones can be created and managed

- manually, by a user in the Pilot.
- by copying them from a template job (manually or via the [Task 'Create Job'](#) on page 1850).
- by the [Manage Milestone task](#).
- by an external system, using JDF/JMF. Learn more in [Integrating with External Systems](#) on page 1769.

#### How can you Use Job Milestones?

Milestones can be used

- as the basis for **status feedback to external systems**. This is the main reason to invest in setting up and using Milestones.









Automation Engine focuses on reporting what happens with a job but not on job organization or job distribution: that is the task of the order management system. What is important is that Automation Engine reports back to such systems and that this ideally happens without manual intervention of prepress users (who have other things to focus on). Learn more in [Informing Other Systems of the Milestones Statuses](#) on page 580.

- in the Pilot,
  - when **filtering** jobs. For example you want to remove all jobs that have a milestone "Finished" confirmed more than 2 weeks ago.
  - as **visual help when tracking the status of jobs**.

### 7.6.2. The Milestones View

This view is different when you are using it in the **Job Overview** mode or in the **Last Used Job** mode.

Both these views use these icons for different milestone statuses:

-  indicates the time the job was created.
-  indicates the current time on the time line.
-  indicates a pending milestone (not confirmed).
-  indicates a selected milestone.
-  indicates an overdue milestone: the current time is later than the due date of the (pending) milestone.
-  indicates a milestone that contains one or more **Actions** that are not all **completed**. Learn more in [Working with Milestone Actions](#) on page 575.
-  indicates a pending milestone of which all **Actions** are **completed**.
-  indicates a confirmed milestone. A milestone must be completed before it can be confirmed.

### In Job Overview Mode

When you are in **Job Overview** mode, you can see all milestones of a (filtered) list of jobs.







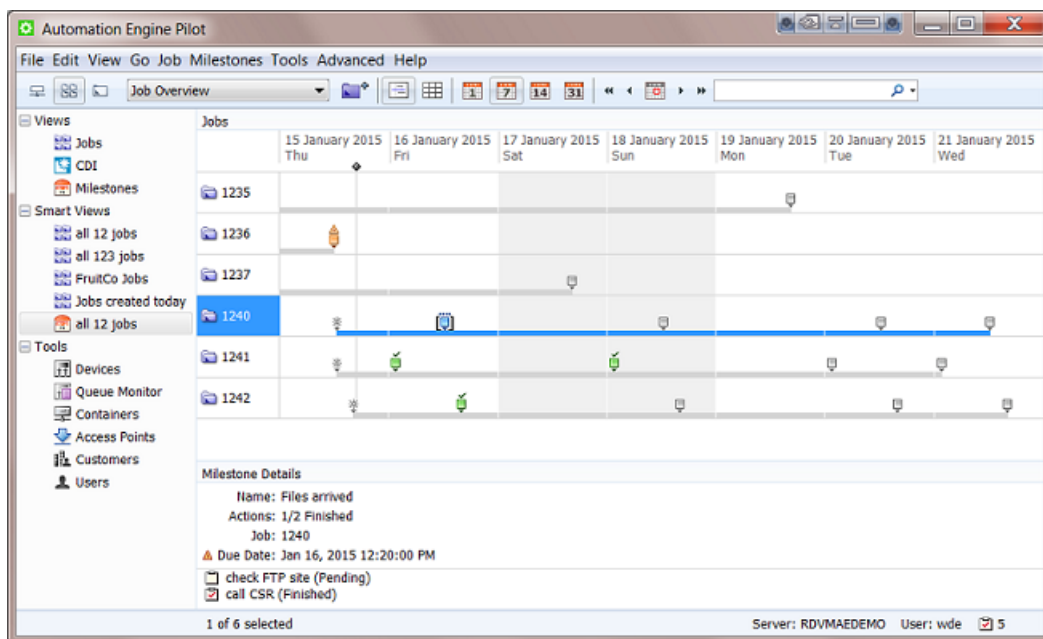

The **Milestones** view offers two types of overview.

#### The Timeline View

The **Timeline View**  shows you the milestones for a defined period.



Use these buttons to define the time period you are viewing:

-     to show 1 day, 7 days, 14 days or 31 days.
-      to show the previous week, previous day, the current day, the next day or the next week.

From the menu **Milestones**, use **Go to Date...** to specify a specific date in the center of your view.



Select a milestone to see **Milestone Details** in the bottom pane.



**Tip:** When hovering over a milestone icon, you will see its name and more details:

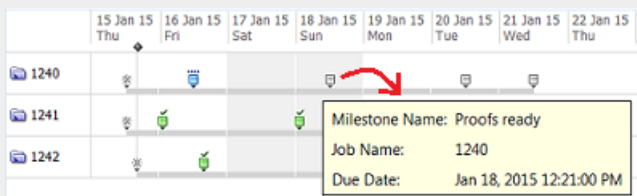

**Tip:** Double click a milestone icon to open the milestone view for that specific job.

### The Status View

The **Status View** shows the milestones and their status in columns.

Jobs	Name	Files arrived	Proofs ready	Approved	Plates ready
	1235				
	1236				
	1237				
	1240				
	1241				
	1242				

Milestones	Milestone Name	Finished Actions	Confirmed	Due Date	Responsible
	Files arrived	1/2	No	Jan 16, 2015 12:20:00 PM	wde
	Proofs ready	0/0	No	Jan 18, 2015 12:21:00 PM	wde
	Approved	0/0	No	Jan 20, 2015 12:21:00 PM	wde
	Plates ready	0/0	No	Jan 21, 2015 12:22:00 PM	wde

Actions	What	State	Due Date
<input type="checkbox"/>	check FTP site	Pending	Jan 16, 2015 1:30:00 AM
<input checked="" type="checkbox"/>	call CSR	Completed	Jan 16, 2015 3:00:00 AM

Go to **View > Select Columns...** to choose which milestones will be shown here and to define the order of these columns.

If no icon appears in a milestone column, this means that this milestone is not defined for that job.

### In Job Mode

In **Last Used Job** mode, the **Milestones** view shows all the milestones for a specific job.

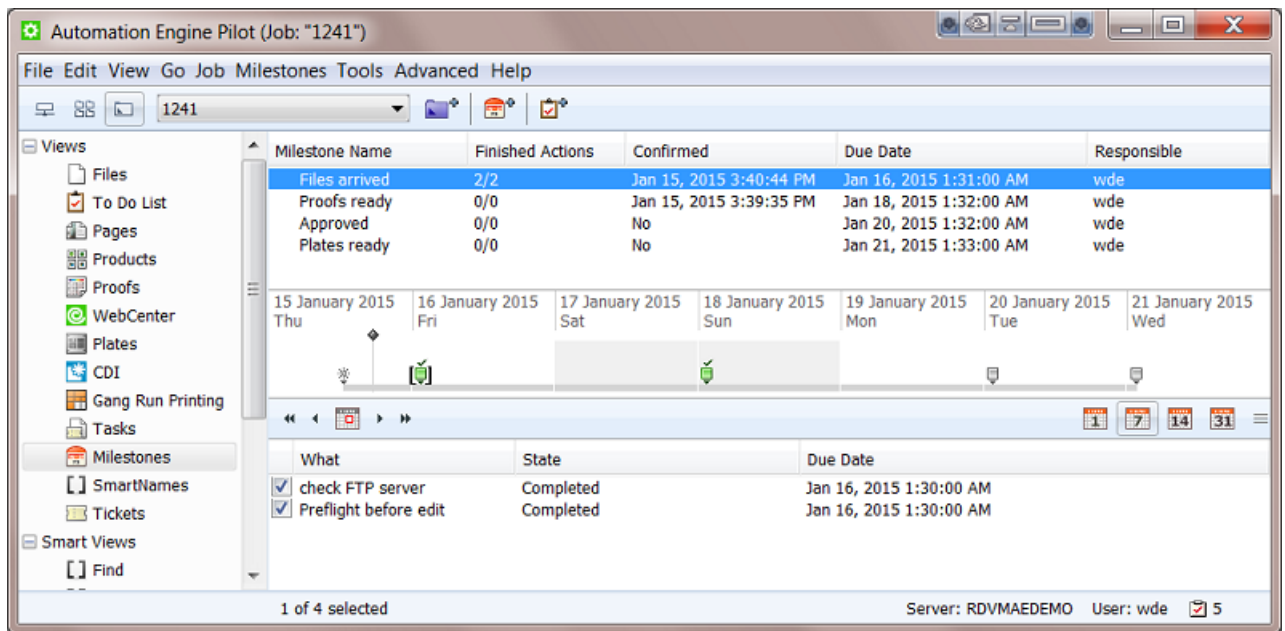

Select a milestone to see it selected in the time line and to see details below about any actions for this milestone.

### Printing out the Job's Milestones

You can use **Milestones > Print Milestones...** to print (or save to PDF) a view of a job's milestones. You can define the printer's page format but the content of the page is fixed. The page shows some major job info and the milestones' timeline and overview.

An example:

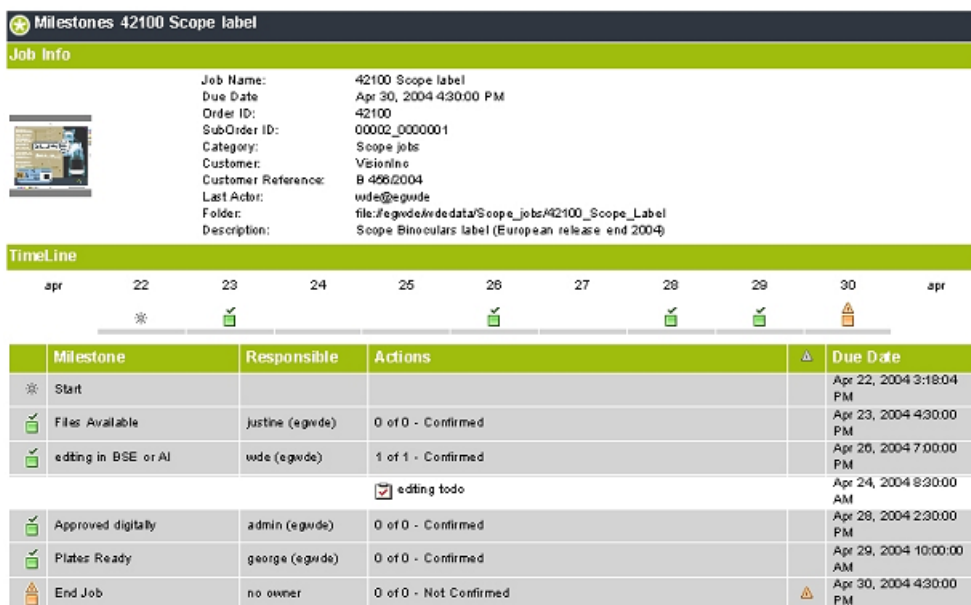



**Note:** The thumbnail of the job shown in this printout is the one you can (manually) add in the **Job** tab sheet of the job setup.

### 7.6.3. Adding Milestones to a Job

#### Adding a Milestone Manually

1. Select your job and open the **Milestones** view.
2. Click , or go to **File > New Milestone**.

3. From the **Milestone Name** list, select the milestone you want to add to this job. If the one you want is not yet in the list, click **Manage...** and create it there. Learn more in [Manage \(Custom\) Milestones](#) on page 574.
4. If you want, add a **Description** for your milestone.
5. Define a **Due Date** and time. This is a mandatory field.
6. If you want, add a **Reminder**. Choose an absolute time or a time relative to the due date. At that time, a reminder will be E-mailed to the **Responsible** user.
7. Select the user that is **Responsible** for this milestone. This is a mandatory field when you set a reminder.
8. Click **OK**.

#### Copying the Milestones from another Job

When you create a new job (manually or via the [Create Job](#) task or via JDF), you can copy the properties of another job (template) to that new job. This can include the milestones of that other job.

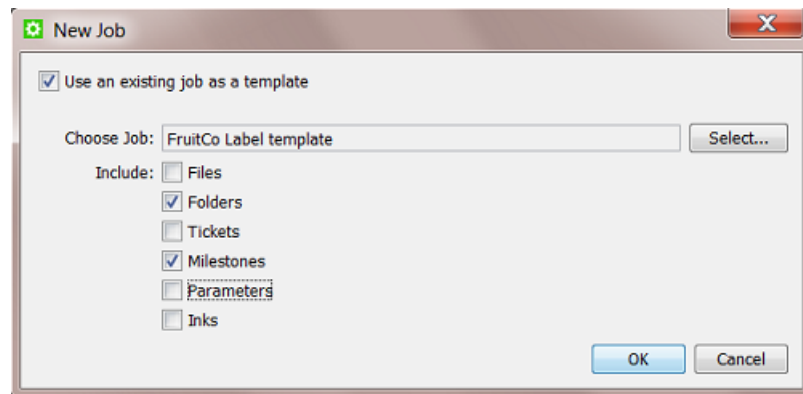

The copied milestones will be set relative to the creation date and time of the new job.

For example, a typical job for your customer 'FruitCo' has a job due date of 9 days after job creation and during that period it includes 3 custom milestones. The due date of the new job that copies those milestones will then be set to 9 days after its creation date. And its milestones will be created relative to the new creation date.

### 7.6.4. Manage (Custom) Milestones

There are many predefined milestones, but you can also create custom milestones.

In the **Milestones** view (in **Last Used Job** mode):

1. Go to **Milestones > Manage Milestones**. This dialog shows you all your milestones and their attributes:

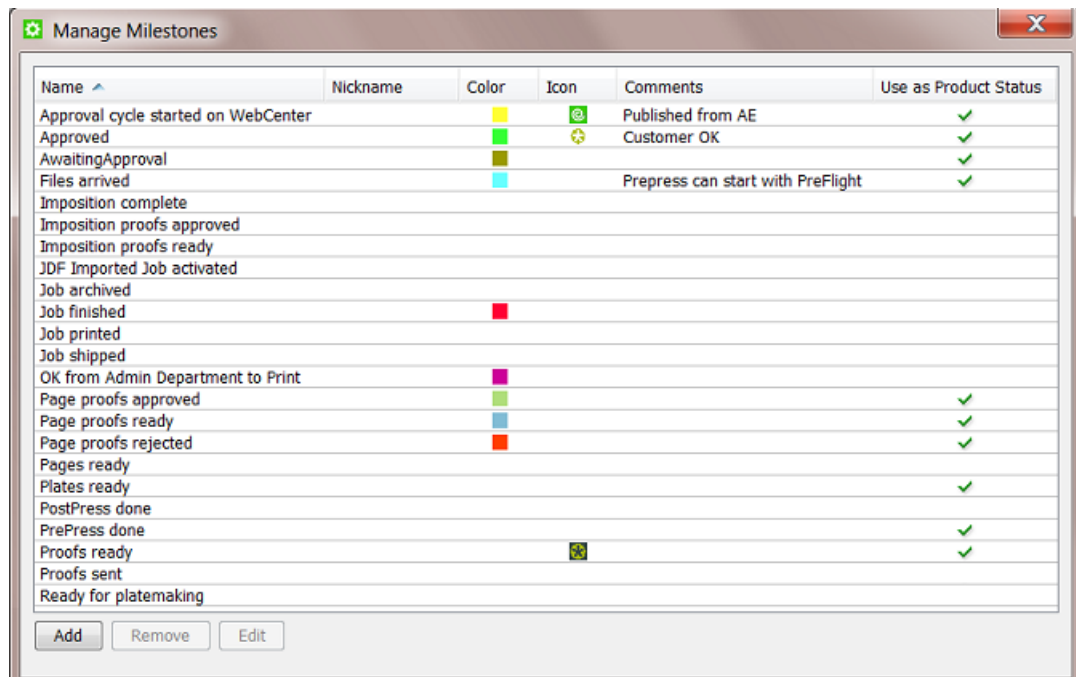

2. Click the **Add** button.

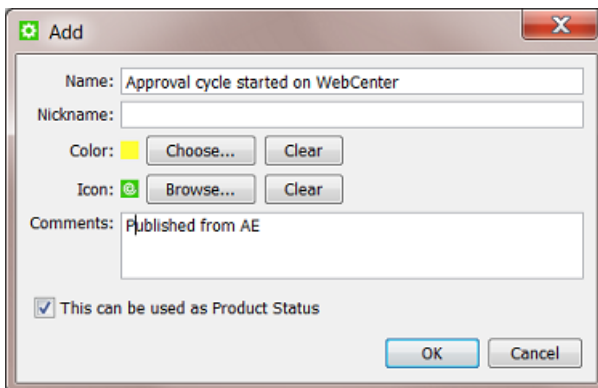

In this dialog:

- Enter a **Name** for your custom milestone.
- You can also enter a **Nickname**, this is the name that will be shown in the Pilot interface. This is also useful when your milestones are managed by JDF/JMF. Learn more in [Integrating with External Systems](#) on page 1769.
- If you want, choose a **Color** and / or browse to an **Icon** to help recognize this milestone. Icons can be based on JPEG/PNG/GIF files and will be automatically scaled to a fitting resolution.
- You can also enter **Comments**. For example to explain all users how this milestone should be used or if an external system is using this milestone information.
- If you use the [Products](#) tool, define if this milestone can also be used as Products status. This option is (since v20) only enabled for custom milestones. Default system milestones have a fixed setting for this.
- Click **OK**. Your custom milestone now appears in the list and is ready to be added to jobs..



**Note:** You can safely remove milestones that you already used in jobs. Those jobs will not loose their (local copy) of the milestone.

## 7.6.5. Working with Milestone Actions

### Concept

A milestone represents a status that you want to reach. A milestone can also list what **Actions** need to be done to reach that state. A milestone can only be **confirmed** when all its actions were set to **completed**.

Some customers use these tools extensively and ask their users to base their daily work on the milestone actions appearing in their [To Do List](#). These users then use custom filters when over-viewing (their) actions. They typically filter their actions based on user, state and urgency.

### Creating Milestone Actions

To add an action to a milestone:

1. Select the milestone in the **Milestones** view.
2. Click  or go to **Milestones > New Action...** or right-click on the canvas in the bottom part of the Pilot.
3. In the **New Action** dialog, enter what needs to be done, who needs to do it and by when.

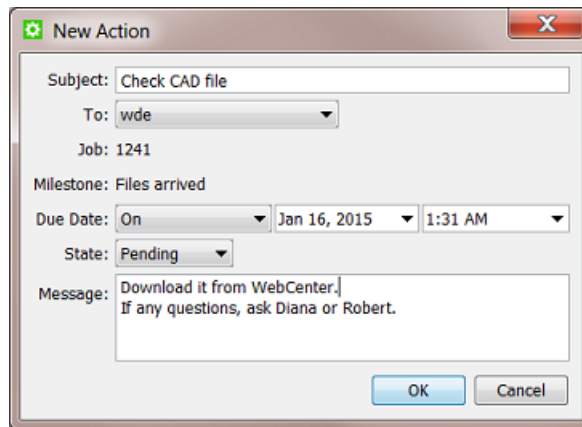

The user that needs to do the action can later change the **State** from **Pending** to **In Progress**, **Completed** or **Aborted**.

### Working with Milestone Actions

Milestone actions appear

- in the **Milestone view**, when in job mode. See a screenshot [here](#).
- in the **To Do List**, as **Milestone Actions**. The To Do list offers some more functionality on these actions:

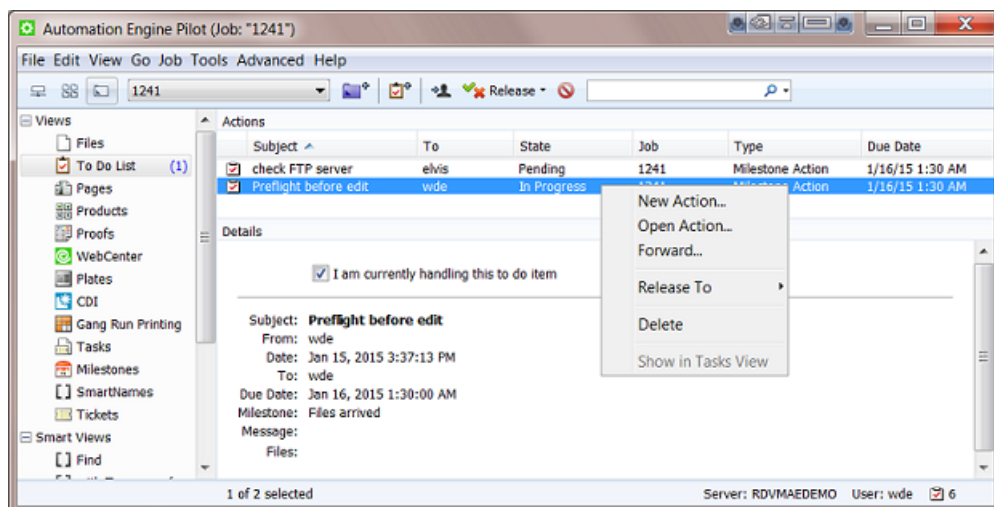

- Right-click to open, delete or create a new action.

- Right-click or click  to **Forward** the action to another user.
- Check **'I am currently handling this item'** to change the state to **In progress**.

Open (double-click) the action to use these extra tools:

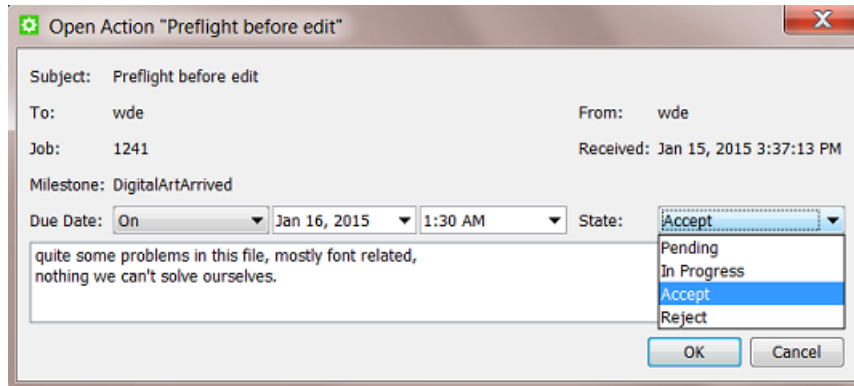

- Change the **State**.



**Note:** Because the names of these states are shared with **Checkpoint Actions**, choosing **Accept** or **Reject** will for a milestone action result in **Done**.

- Change the **Due Date**.
- Add a **Message**.

For example: a user opens his to do list in the morning and uses a filter showing all the actions on his name that have a due date before noon, in the state **Pending** or **In Progress**. He can also use the column **due date** to sort by urgency.

### 7.6.6. Using Milestone Statuses to Filter Jobs

The filters that you make in Job Overview mode can also be based on milestones.

See this example of a filter that was saved as a **Smart View** named "Still Need Plates Today". It only shows jobs with an unconfirmed milestone "Plates Ready" that has a due date today:

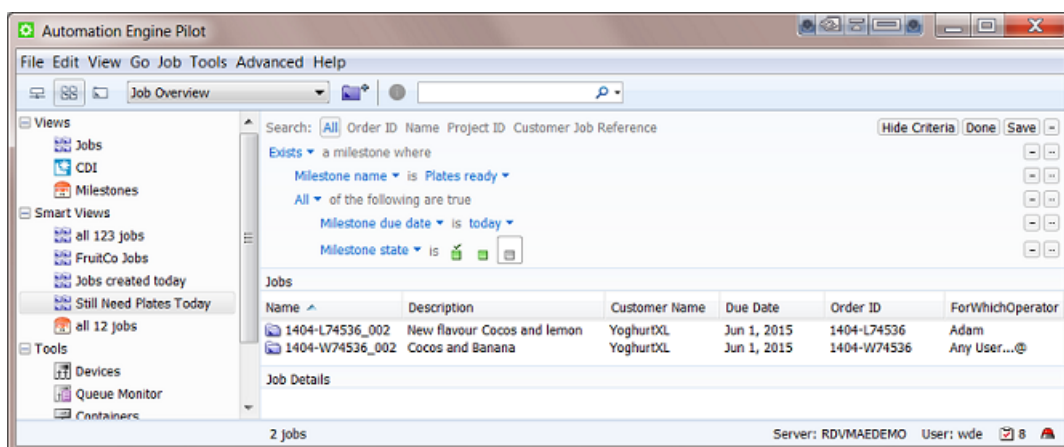

Learn more on creating such filters in [Job View Filters](#) on page 542.

### 7.6.7. Using Milestones in Workflows: the Manage Milestone Task

#### Concept

Using milestones in workflows enables these principles:

- Milestones can help control a workflow. A workflow can check the status of a milestone before continuing (in a specific direction). Use the workflow control **Router** to do this. See an example [here](#). Learn more in [Router](#) on page 811.



**Tip:** When you also work with the Products tool, then check if the dedicated **Wait for Product Status** task is a better alternative.

- The **Manage Milestone** task helps to automate working with milestones. This task serves to create and confirm milestones as a workflow step. This enables a lot of automation when working with milestones. And you can also use it to hold workflows. Learn more below.

See an example of a workflow that automatically confirms four milestones:



#### The Manage Milestone Task

You can use this task to automatically decide one or multiple of these milestone attributes:

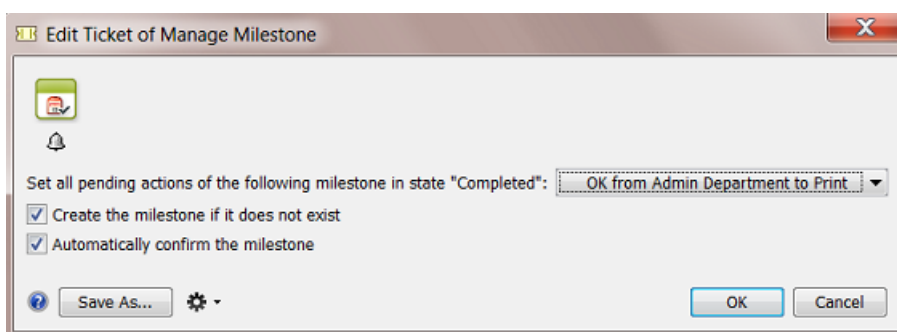

- **Set all pending actions of the following milestone in state "Completed":** Select the milestone you want to set as "Completed". Learn more about **Milestone Actions** in [Working with Milestone Actions](#). This setting is mandatory.
- **Create the milestone if it does not exist:** If the above selected milestone you selected was not yet added to the job, check this option to add it (otherwise the task will fail). The milestone will be created with the status "Completed".
- **Automatically confirm the milestone:**



- Check this option to set the above selected milestone as "Confirmed" and have the workflow continue with its next step(s) or with any task that was waiting for this milestone to be confirmed.
- Do not check this option if you are still waiting for a confirmation. The task will then serve as a hold-point: it will pause the workflow until that milestone is confirmed.
- In the **Workflow Editor**, this step then will jump up and down, as a signal that a user intervention is needed:



Right-click the file-icon and choose to **Open Milestone...** or to **Show in Tasks View**.

- In the **Tasks** view, you will see the phase **User intervention needed**.

File Name	Task Type	Progress	Phase	State
banana.pdf	Manage Milestone	0%	User intervention needed	
banana.pdf	Workflow	100%		
banana.pdf	Workflow	0%	Running	

Click on the red text to open the milestone dialog where you can change any setting.

If you check **Confirm Milestone** (and click **OK**), the workflow will continue. If you can not confirm this milestone yourself but for example need the help of someone else, then type in a description and change the responsible user.

- In the **Milestones** view, right-click to open the milestone or directly click in the column **Confirmed** to change it to **Yes**.

Milestone Name	Finished Actions	Confirmed	Due Date	Responsible
PrePress done	0/0	No	Jan 22, 2015 2:43:00 PM	toto



**Tip:** Some customers make the manual confirmation of a milestone easy by offering the users a favorite ticket that only (creates and) confirms a milestone. This is useful when that user is aware of a status that Automation Engine has no information on.

For example: A plate room operator checks plates that come out of the developer. He reads their job number on the plate and types it in as a job filter in his simplified Pilot. He then launches the appropriate favorite ticket: **Plates OK** or **Plates NOT OK**.

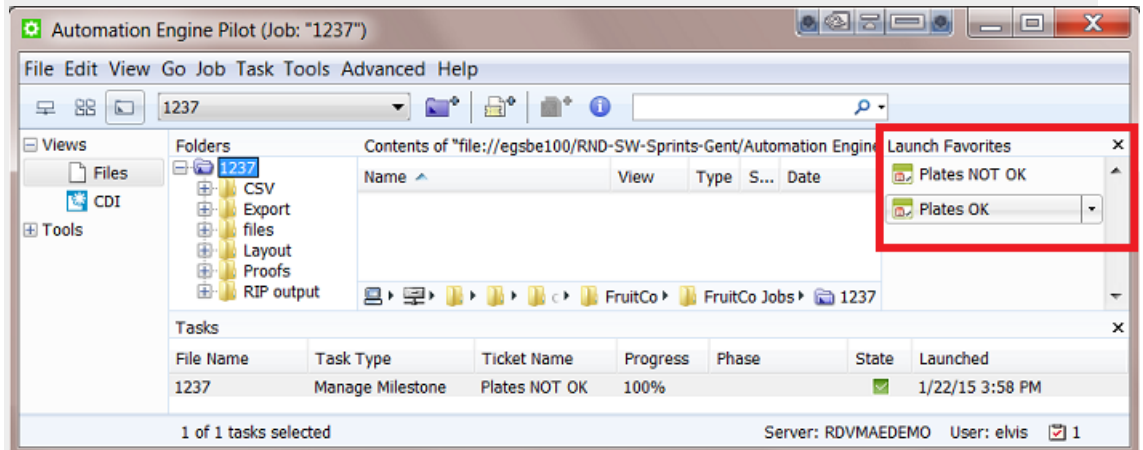

This information can now automatically change a workflow and/or be sent out to the system that does the press planning. Learn more about such feedback in the next section.

### 7.6.8. Informing Other Systems of the Milestones Statuses

The milestone status of an Automation Engine job is often more important to external people than to users of the Pilot. Many parties want to be kept up to date about the latest status in prepress, both colleagues and customers.

External systems are not always interested in all prepress details. You can choose to only inform them on some specific milestones.

These are tools that help inform other systems and their users:

- Add a **notification** to your **Manage Milestone** task. This can be an E-mail notification or the same message can also be written in an XML file for an external system to read. Learn more about the type and content of such messages in [Task Notifications](#) on page 98.
- Or you can use one of many tools dedicated to help integrate Automation Engine with external systems. Typical methods are
  - write out XML files
  - write directly in the database of the external system
  - when the external system is capable of subscribing to JMF signals, you can set up the automatic sending of JMF signals when a milestone is confirmed.

For more information on these feedback tools, see the dedicated chapter [Integrating with External Systems](#) on page 1769.

## 7.7. About Removing Jobs

---

### Concept

An Automation Engine job represents a Work In Progress. It is expected that you remove the job when the work is done.

Removing a job means that it is removed from the Automation Engine jobs database. You have the option to keep the job folder data.

When you remove a job,

- all finished tasks in that job will be deleted. If you wish to keep those tasks, use the [Task Cleanup Rules](#) to move them (earlier) to the [Task History](#) tool.
- if that job still has unfinished tasks, you will be asked before removing the job to confirm that they can be cancelled and deleted.
- all **Actions** for that job in the **To Do List** will be deleted.
- any setup of (the old tool) Hot Folders in that job folder will be removed.
- when you choose to not delete the job folder, all the job's setup parameters will be stored in a subfolder 'config' (this is the information that was inside the database).
- the job will disappear from the Job Overview in the Pilot or workspace.
- in the Containers view, the blue colored folder icon will turn back into a standard yellow folder icon.
  - That is now a folder from where you could re-create that job later (using the data in the hidden 'config' folder).



**Note:** The **Archive Job** task allows to remove the job (from the database) and move the job folder to a different place in the network. Learn more in [Task 'Archive Job'](#) on page 585.

You also have tools to reactivate the job, to recreate it back into the jobs database. Learn more below.

### Manual and Automatic ways to Remove Jobs

You can remove jobs

- manually, using the Pilot. Learn more below.
- by use of a workflow. This is usually a combination of the [Select Job](#) workflow control followed by the [Remove Job task](#). Use the links to learn more.
- fully automatic, by having an external system launch a workflow that removes jobs. Also JDF can remove jobs directly. Learn more in the chapter [Integrating with External Systems](#) on page 1769.



**Note:** In an AE SaaS setup, you can also inactivate Jobs by moving them to Esko Cloud. Learn more in [AE SaaS: When your AE is in a Data Center](#) on page 1633.

### Removing a Single Job

To remove a single job, select the job and press **Delete**. You can also right-click (or go to the menu **Job**) and choose **Remove Job...**

You will be asked to confirm. You can choose to also remove the job folder and its contents.

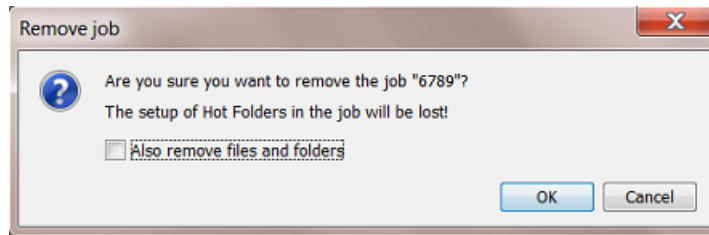

**Attention:** There is no way to **Undo** the removal of the files and folders.

### Removing Multiple Jobs

In the Job Overview mode, you can select multiple jobs and remove them in the same way as described above. You will also get the option to keep or remove (all) their job folder data.



**Note:** It is good practice to use a smart filter when you select multiple jobs to be deleted. For example: all jobs that have their milestone 'finished' confirmed more than a month ago.



**Note:** There is no "Remove Job" task, so you can not remove jobs as a workflow step.

In **Edit > Preferences**, you can decide to avoid getting (many) questions when you remove multiple jobs:

- questions about jobs being in use by other users. A job is 'in use' when a user has this job open in his Pilot.
- questions about jobs containing unfinished tasks.

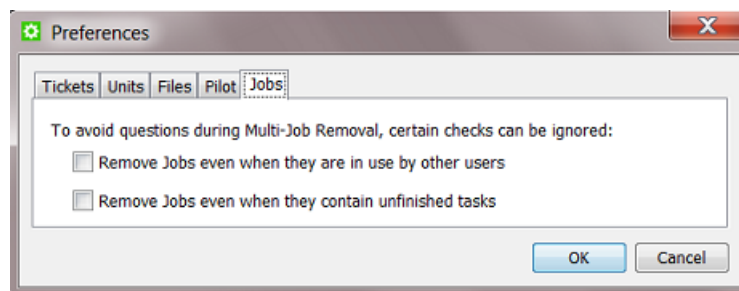

Learn more in [Pilot Preferences on Multi Job Removal](#).

### Recreating a Job that was Removed

When a job was removed but the job folder data is still available, you can recreate that job back into the jobs database.

There are two ways to recreate a job:

- Recreating a job manually. Follow these steps:
  1. In Containers view, select the yellow folder that used to be the job folder of a removed job.

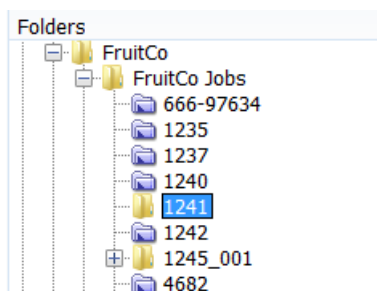

- Right-click (or go to the menu **Job**) and choose **New Job...**. When a previous job setup is detected in that job folder (in the subfolder 'config'), you will be able to recreate that job. Choose to **Reuse the previous setup**.

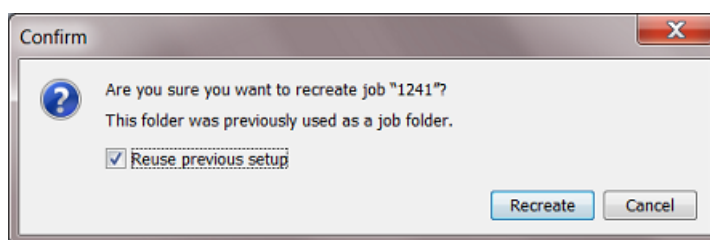

- Click **Recreate**. The renewed job will be opened and will contain the previous job setup parameters, subfolders and local (blue) job tickets.
- Recreating one or multiple jobs with the **Restore Job** task.

Learn more in [Task 'Restore Job'](#) on page 587.

## 7.8. Tasks you can Launch on Jobs

---

These are the tasks that you can launch **only** on Automation Engine jobs:

- The [Relocate Job task](#) moves the job folder of a job to another place (within an AE Container).
- The [Archive Job task](#) removes a job and exports all its data and metadata into a ZIP file.
- The [Restore Job task](#) re-creates a job from a ZIP file that was created by the **Archive Job** task.
- The [Check Job Parameters \(Classic\) task](#) checks or correct the input file's barcode and inks according its job parameters.
- The [Remove Job task](#) is used to remove jobs as a step in a workflow. This task is then preceded by the [Select Job](#) on page 819 workflow control.
- Only in an AE SaaS setup, [several tasks](#) enable to move Jobs to Esko Cloud, where they become inactive jobs. Learn more in the chapter [AE SaaS: When your AE is in a Data Center](#) on page 1633.

Like all tasks, these tasks can also be triggered by an external system. Learn more in [Integrating with External Systems](#) on page 1769.

The [Create Job task](#) is documented in the chapter [Integrating with External Systems](#) on page 1769.

### 7.8.1. Task 'Relocate Job'

#### Concept

This task allows to change the location (the URL) of an Automation Engine job folder. The job itself does not change, only the path of its job folder.



**Attention:** The term 'location' in this task only refers to the place (URL) the job(folder) has in one of the AE Containers. It has no relation to the Location that you can define for a Job or Product to enable filtering of data per group of users (as explained in [Locations](#) on page 220).



**Restriction:** You can not launch this task as part of a workflow.

#### Task Options

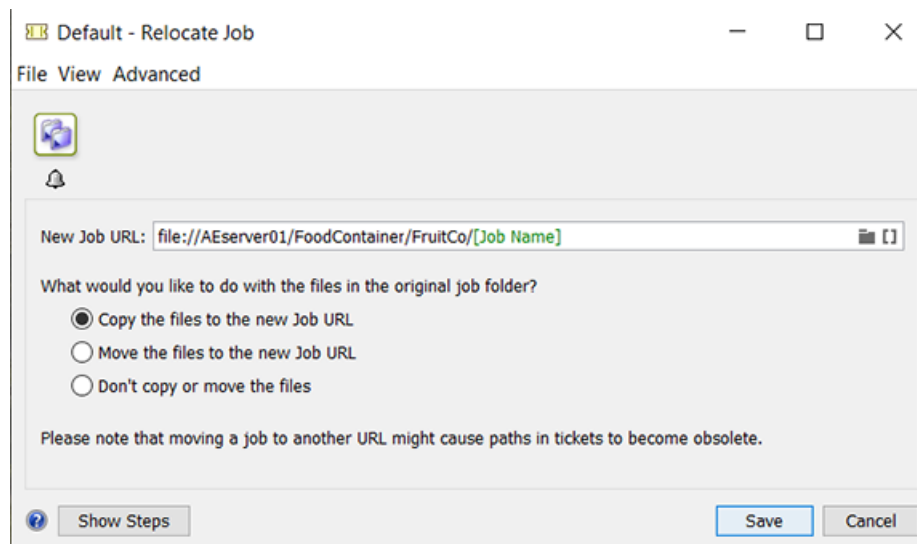

- Enter the **New Job URL**. Keep in mind to end the path with a SmartName that defines the name of the job folder.
- You can choose to:
  - Copy the files to the new Job URL.
  - Move the files from the original job folder to the new one.
  - Not copy or move the files. The relocated job will then have an empty job folder.



**Warning:** If you move a job folder without using a tool from Automation Engine, the job setup field for the job folder will not be updated and the Pilot will show warnings. Automation Engine will keep trying to retrieve your missing files and this can slow down your server.

### Relocating Multiple Jobs

In Job Overview mode, (filter and) select the jobs you want to relocate. Right-click and choose a **Relocate Job** ticket:

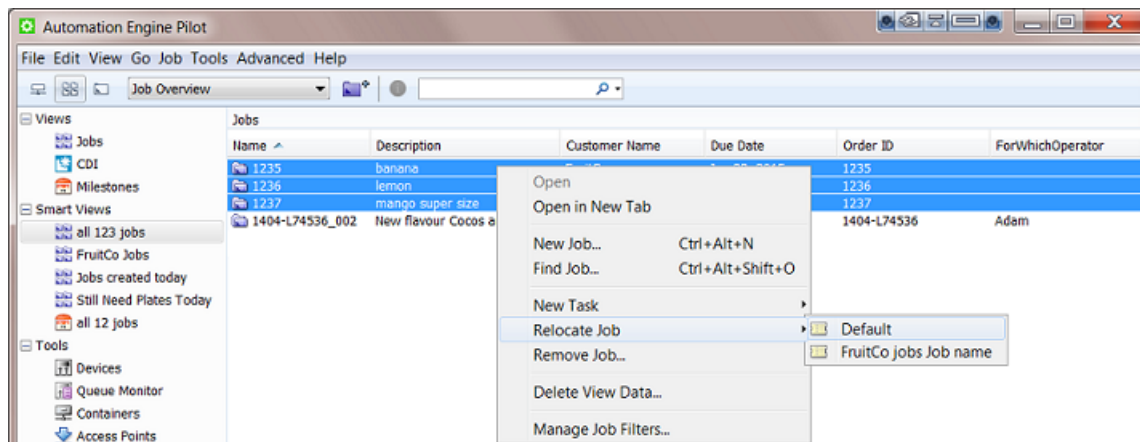

## 7.8.2. Task 'Archive Job'

### Concept

The **Archive Job** task removes a job from the jobs database and exports the data in a form that enables to restore the job later.

Typical for this task is that it exports the job metadata as well, these are the job setup parameters. This metadata makes it possible to restore the job (back) later.



**Note:** The job's metadata is exported in a subfolder named 'config'.



**Note:** When you launch the **Zip task** on a job, the task only ZIP's the data inside the job folder, not the job's metadata.



**Note:** When archiving (removing) a job, the tasks that were launched in that job will be deleted. If you want to keep these tasks, use the [Task History](#) tool. This tool allows setting up rules that automatically move those tasks to a separate database (before archiving the job).

### Task Options

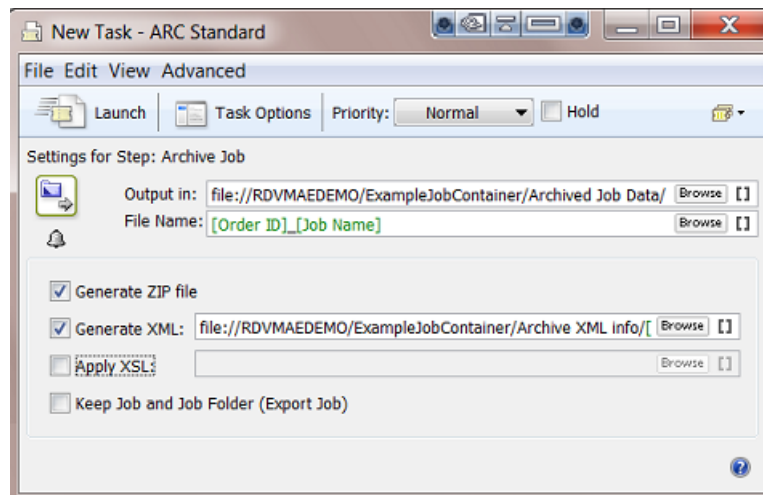

- **Output in:** define where you want to write this archive data. For example some customers use a 3rd party backup/archive solution that scans specific network folders for new incoming data. This system then archives that data online or writes it on a backup medium.
- **File Name:** define the name of the file in which all data will be stored. When you do not choose to generate a ZIP file, this will be a folder with subfolders.
- **Generate ZIP file:** deselect this option if you want to move the job folder to the above location without ZIP'ing all data.
- **Generate XML:** select this option to generate an XML file that describes this job. Such an XML file can be useful for a 3rd party archive solution that for example uses it to build up its search database.
- **Apply XSL:** select this option if you want to format the XML file using an XSL style sheet from a 3rd party archive solution.
- **Keep Job and Job Folder (Export Job):** deselect this option if you want to delete the job folder once it is successfully archived.

Select this option if you still want to keep the job in the job database and also keep the job folder in its original location. Here are some examples when to choose this:

- To use this task as a job backup tool.
- To exchange that job with another Automation Engine. For example to send a job to another plant of your company (that also has Automation Engine) or to share the job with Esko Customer Service.

### Archiving Multiple Jobs

In **Job Overview** mode, right-click the selected jobs and choose your **Archive Job** ticket.

Here is an example of a smart way to archive multiple jobs. The filter lists all jobs that have their milestone "Job Finished" confirmed this week:



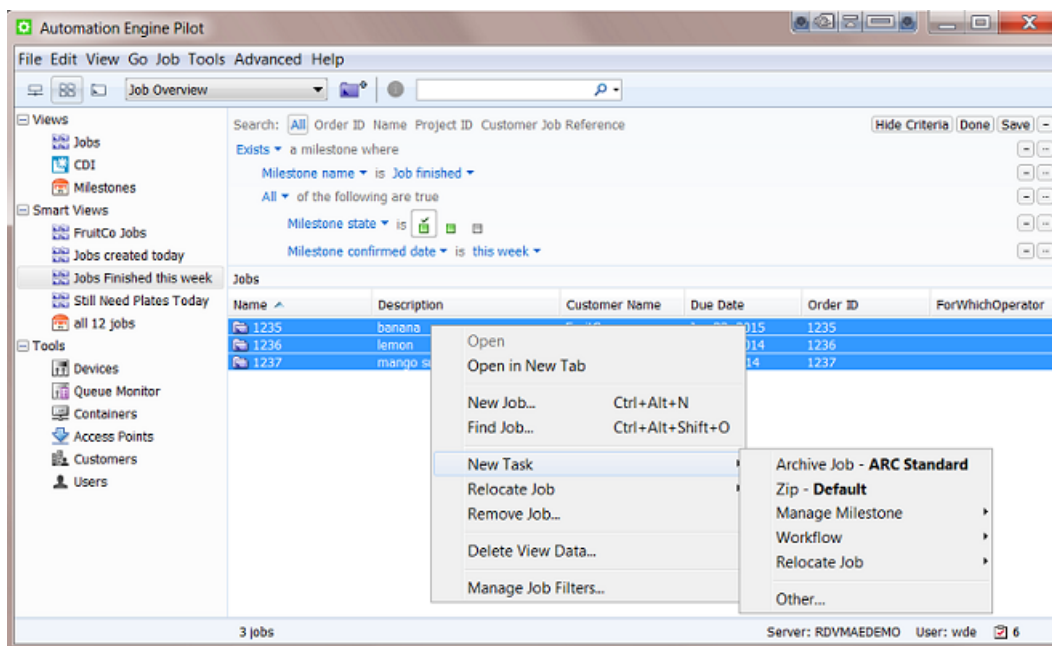

### Using the Archive Job Task in a Workflow

You can end a workflow by archiving the job that the workflow was launched in.

Here is an example:



Notice these steps:

- After the plate making stage, the workflow waits for 2 weeks.
- It then sets the milestone "Ready for Archive" but without the option to confirm it. This triggers a request for a user intervention (learn more about [this option the Manage Milestone task](#)).
- When a user confirms this milestone, the workflow continues and archives the job.

## 7.8.3. Task 'Restore Job'

### Concept

This task allows to restore jobs back to the Automation Engine job database that were previously archived using the [Archive Job](#) task.



**Note:** When the **Restore Job** task is a step in a workflow, it will only have the **error** output pin.

### Possible Input Types

The input file for this task can be

- a ZIP file created by the **Archive Job** task.
- a job folder created by the **Archive Job** task.



**Important:** The ZIP file or the folder need to be created by a version of Automation Engine that is equal or lower than yours.

- an XML file that refers to the location of a ZIP or folder created by the **Archive Job** task.

The root node of the XML needs to have an XML attribute named "Location". The value of this attribute is the URL to the ZIP or archived job folder. Here is an example XML (it looks like the XML generated by the Archive Task):

```
<?xml version="1.0" encoding="UTF-8"?>
<Archive Location="file://aeserver01/Food/Archived Job Data/1237.zip"/>
```

### Task Options

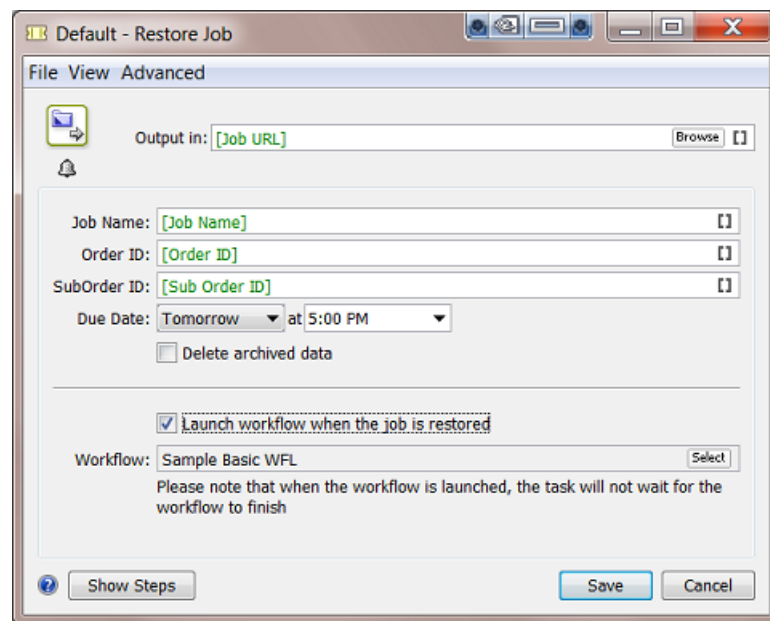

- **Output in:** Define where you want to place the restored job folder. Use [Job URL] when you want to restore the job to its original location and with its original job folder name.



**Note:** When you restore to a server that has a different name (typically a new AE server), then avoid using SmartNames that result in a value that contains that name of the old server. For example, [Job URL] will try to restore to a path containing the name of the old server. Consider defining an output path that also uses [Server], the SmartName for the name of the current server.

- **Job Name:** Define the name of job once it is restored. Use [Job Name] when you want the job's original name.
- **Order ID** and **SubOrder ID:** Similar to the job name, define a new ID or use SmartNames to use the ID's of the original job.

- **Due Date:** Set the job's new due date.
- **Delete archived data:** Select this option if you want to delete the archive data after restoring the job.
- You can choose to **Launch a workflow when the job is restored**. The advantage of this function is that the chosen workflow will be launched *in the context of the restored job*. This means that all the used SmartNames will get their value from *that* job.



**Important:** If the **Restore Job** task itself is part of a workflow, the workflow that is chosen in this task will start immediately, as a separate workflow. It will not wait for the workflow that contains the **Restore Job** task to finish.



**Note:** This functionality is used when using 3rd party (hotfolder based) archiving solutions.

## 7.8.4. Task 'Check Job and Product Parameters'

### Concept

This task checks if the barcode and inks (separations) parameters of the input PDF(+) file match those defined in its Job setup or as parameters of the Product Part it represents. The task can also apply (enforce) those parameters into the PDF file.



**Note:** This task does not support Normalized PDF files (because those use a *different screening model*). For those, use the classic version of this task (split over a *a separate one for Job parameters* and *a separate one for Product parameters*).

### General Behavior

- **Both for inks (separations) and barcodes:**
  - First the Product Part parameters are checked. If none were defined on Product Part level, then the Job parameters are used.
  - If a Job and Product parameter contradict each other, the value from the Product parameter is used.
- **For inks (separations):**
  - If the document contains placed art and the task is asked to apply screening properties, then the task will also adjust screen sets in the placed art. When the placed art was linked to the original document it will be unlinked without any extra message.  
Objects with screen set 'None' will get a screen set matching the Job or Product parameters.
- **For barcodes:**
  - For barcodes the Product Part parameters are merged with Job parameters. Priority is given to the Product part parameters.
  - This task supports barcodes created in ArtPro+ and DeskPack barcodes saved as PDF+. (DeskPack barcodes with a "Stroke Weight" will become protected objects.)
  - When using a SmartName, detect the required value via a right-click on the wanted option and choose '**Copy Parameter Value**'. Then paste this value in any text field or editor to see and read it.

### Task Settings

- **Separations**
  - **Do not check.** Select this if you want the task to only check barcode parameters.

- **Apply properties:** The task applies the separations parameters and printing methods as specified in the job parameters to the input file.  
 If any ink in the object's screen set does not have a defined Ruling or Angle or Shape, then the default values from the bottom part of Job Inks will be merged into the ink.  
 If the input file is a product part for which product part inks are defined, then the job parameters are ignored and the product parameters will be applied.
- **Apply properties and order:** The task applies the separations attributes, printing method and order as specified in the job parameters to the input file.  
 If any ink in the object's screen set does not have a defined Ruling or Angle or Shape, then the default values from the bottom part of Job Inks will be merged into the ink.  
 If the input file is a product part for which product part inks are defined, then the job parameters are ignored and the product parameters will be applied.
- **Check properties and order:** The task ends in error when the separations attributes, printing method and order as specified in the job parameters do not match those in the input file.  
 If the input file is a product part for which product part inks are defined, then the job parameters are ignored and the product parameters will be checked if they match.
- **Barcodes**
  - **Do not check:** Select this if you want the task to only check separations parameters.
  - **Apply properties:** The task applies the barcode parameters in the job parameters to the same type of barcodes in the input file.  
 If the input file is a product part for which barcode parameters are defined, then the job parameters are ignored and the product parameters will be applied.
  - **Check properties (top level only):** The task ends in warning when the barcode parameters in the job setup do not match those in the input file.  
 If the input file is a product part for which product part barcode parameters are defined, then the job parameters are ignored and the product parameters will be checked if they match.
  - **Check properties (include placed art):** Same as above but now also including any placed art inside the input file.



**Note:** Only the checking of barcodes in placed art is possible ; applying barcode parameters is not possible.

### 7.8.5. Task 'Check Job Parameters (Classic)'

This task serves to check if your file matches specific parameters as defined in your job setup. You can also use it to automatically correct the file according those parameters.



**Important:** This task only supports Normalized PDF(PLA) files.



**Note:** For the task to function properly, the input file should be part of an Automation Engine Job.

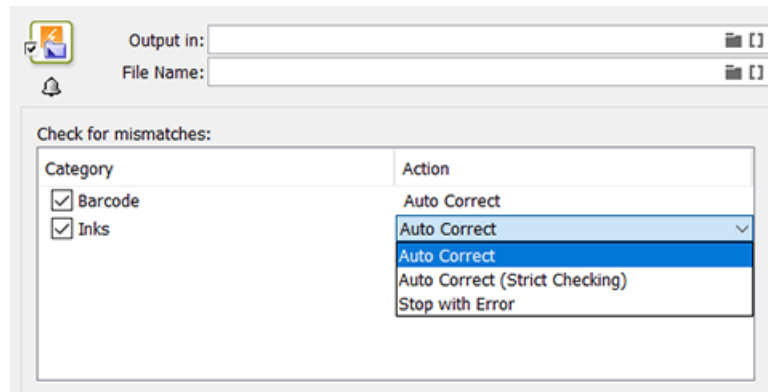

### Category Barcode

For barcode settings, you can select:

- **Auto Correct** when you want to correct the file with what is specified in the job's [Barcodes tab](#) .  
For example, your Normalized PDF includes an Esko barcode of type EAN-13 and code 123456789012, and your job parameters specify an EAN-13 with code 5449000050205, then this task will automatically correct the barcode number in the PDF to 5449000050205.
- **Stop with Error** when you want the task to stop with an error if the barcode in the job's [Barcodes tab](#) does not match the barcode in the file.



**Note:** This task only checks barcodes created in Esko PackEdge or by using Esko's barcode plug-in for Adobe Illustrator (DeskPack). If the task does not find such a barcode, the task will end in a warning.



**Note:** You cannot use this task to check and auto correct barcodes in normalized PDFs generated by **ArtPro**.

### Category Inks

For inks, you can select:

- **Auto Correct** when you want the task to correct attributes of the file's inks according what is specified in the job's [Inks tab](#).
- **Auto Correct (Strict Checking):** Same as 'Auto Correct' but now also the order of the inks is corrected (according the job's ink parameters).  
In this strict setting, the task will finish with an error if it finds unexpected inks (inks that are in the file, but not defined in the job parameters) and with a warning if it finds missing inks (inks that are not in the file but defined in the job parameters).
- **Stop with Error** when you want the task to stop with an error if the job's ink parameters are different than those in the file.

**Table: Some example situations when checking inks**

Missing ink (ink specified in Job Parameters but not in file)	Always results in Warning
---------------------------------------------------------------	---------------------------

Wrong sequence of inks	Results in Error in case of strict checking, otherwise: no message
Unexpected ink (ink in file which is not in Job Parameters)	Results in Error in case of strict checking, otherwise: no message

### 7.8.6. Task 'Remove Job'

The **Remove Job** task serves to remove one or multiple jobs.



**Tip:** Learn more about what happens when jobs are removed in [About Removing Jobs](#) on page 581.

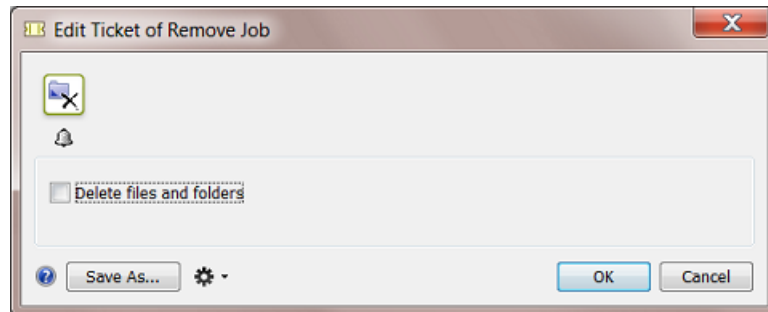

#### Using the Remove Job Task in a Workflow

This task needs a job as input. This is why, in a workflow, you typically use the workflow control [Select Job](#) in front of this task.

#### Having Jobs Removed by an External System

Any task can be launched by an external system. In workflows where jobs are created automatically through integration with an external system, that same system can also decide when to remove jobs. For example a business system triggers the **Remove Job** task right after it invoiced the job. Learn more in [Integrating with External Systems](#) on page 1769.

#### Only Removing the Job from the Database or also Removing the Files?

You can choose to also **Delete the files and folders**. This will delete the whole job folder.



**Note:** In a workflow, when this option is active, the **Remove Job** task step does not have an output pin and so represents an end point for that workflow.



**Note:** When the files and folders were not deleted, you can later still recreate the removed job with the same job settings as before. To do this, select the ex-job folder and choose **New Job** or launch the task **Restore Job**.

### What about the Job's Tasks?

As usual, when a job is removed, the [Task Cleanup Rules](#) are applied. These rules decide which tasks move to [the Task History](#) and which ones are deleted. After applying these task cleanup rules (if any), any remaining tasks of this job are deleted.

## 7.8.7. Task 'Change Location of Jobs'

The term '**Location**' here refers to the concept of data-filtering as explained in [Filtering on Locations after consolidating all data](#) on page 1676.

In a setup where you decided to use this Location attribute for Jobs, you might start with many Jobs that do not have this attribute set yet.

This task enables to set (or update) this location attribute for all Jobs that match the filter defined in the task ticket.

You can not start this task by first selecting a set of Jobs ; this selection is built into the task itself.

1. Make a task ticket with the wanted filtering of jobs.
2. In the Workflow Editor, add this ticket to a workflow and save this workflow.
3. Launch this workflow (from within the editor or later for example as a favorite ticket).

## 7.9. Automated Creation of Jobs

---

Most of the job setup parameters originate in another system, often the order entry part of the business system. It could also be a web portal where job specifications were first entered.

When someone already entered this data manually, we advise to not re-enter that data. We therefore strongly advise to get your jobs created automatically.

The chapter [Integrating with External Systems](#) on page 1769 explains how this can be done. It describes the many available techniques and also offers exercises.

Here is a summary of how jobs can be created automatically:

- by the [Create Job task](#) that, as part of a workflow, picks up the job setup parameters via SmartNames or from an external (XML) file(s).
- by an [Access Point](#) that interacts with the external system and launches a workflow that uses the found information in the **Create Job** task.
- via JDF/JMF commands from an external system, sent directly to Automation Engine's JDF channel.

## 8. Products

---

### 8.1. Products Basics

---

#### 8.1.1. The Products Concept

##### What is an Automation Engine Product?

An Automation Engine Product is a one-up graphics production item stored in the Automation Engine Products database. A Product represents a Stock Keeping Unit (SKU). A Product is what you Step & Repeat on a plate or press, possibly combined with other Products.

As explained in [The Job Concept](#) on page 538, a Job is a to do item for Automation Engine. A Job is not a thing, it is an activity with a specific goal. A Job is temporary, you delete it when the Job is done. A Product does represent a thing and is not temporary, you expect it to come back in other production (output) orders. For example, you could have 200 Jobs, 20.000 Products and 20.000.000 files.

In [Types of Jobs](#) on page 539, we also describe that a Product is the result of a "Prepress Job-Order", in which the goal is to get a design ready for production and customer approved. From that moment on, the Product can be used in many "Production Job-Orders", where the only task is to produce (output) it.

It is easier to integrate Automation Engine with a business system when both use the same concepts. It will be easier to translate the incoming orders into a prepress (data) context. It will also be easier to give feedback to that system about statuses in prepress.

##### The Main Principles when Working with Products

Working with Products typically means following this process:

- You first check your data structure. Working with Products requires that your Job data are split from your Product data. Learn more in [Products Data Structure](#) on page 599.
- Then you build up your Products database. Learn more about how to automate this in [Creating Products](#) on page 616.
- Then you start linking Product(s) into your Jobs. This way, the Product data files are not inside the Job Folder. Product data are independent: today they can be linked to Job 123 and next time to Job 456. They can even be linked to several Jobs at the same time.

In Automation Engine, this temporary relation to a Job is a temporary link between items in the Product database and items in the Jobs database:



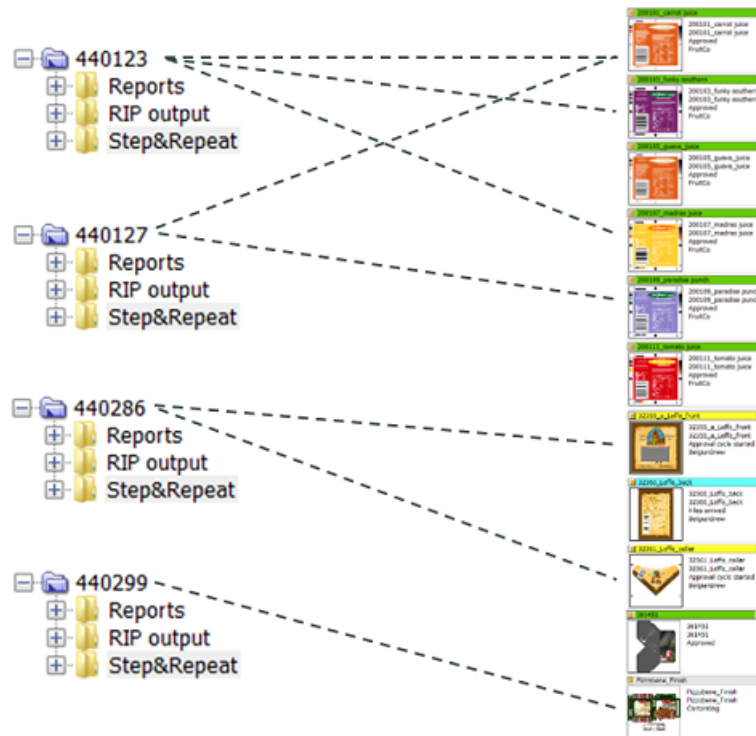

Here is an example how this looks in the Pilot: the Job 440123 links to 3 Products:

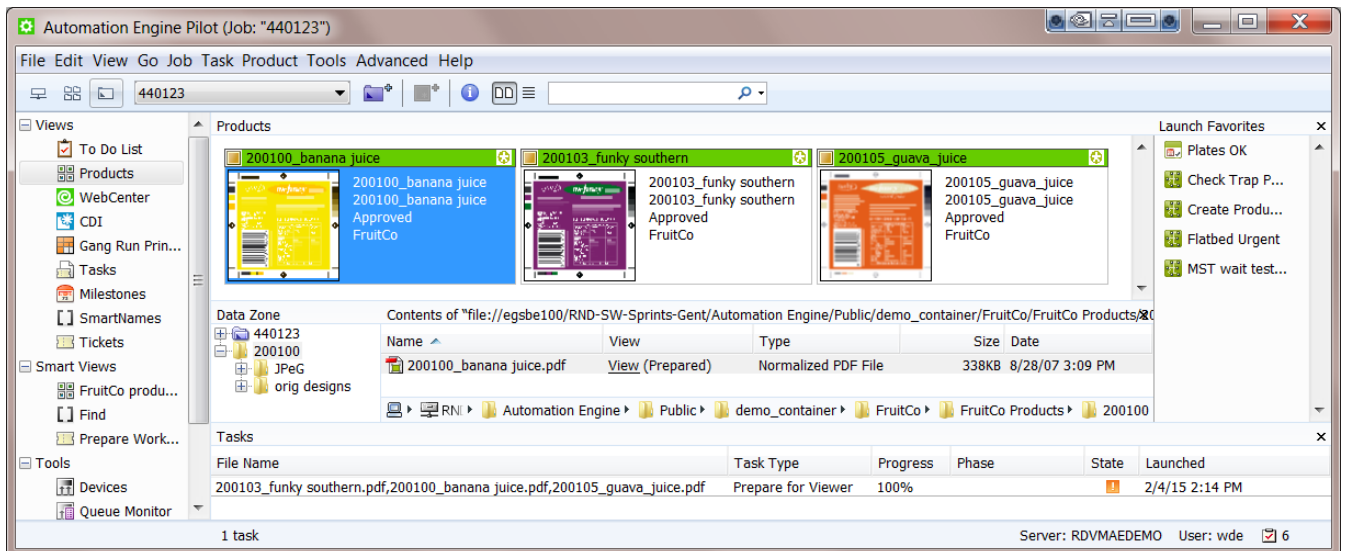

**Note:** You can work with Products without working with Jobs. However, in all classic print production environments Esko advises to use the Jobs concept.

### Product File Formats

These file formats are supported as Automation Engine Products:

- PDF



**Note:** Non-Normalized PDFs cannot be checked for barcode parameters. Learn more in [Task 'Check Product Parameters \(Classic\)'](#) on page 632.

- ArtPro
- Adobe Illustrator (Esko DeskPack workflow).



**Note:** You will only see a product part thumbnail when the AI file was saved as PDF compatible.

It is possible to add other file types to the Products database, but it will become clear that Automation Engine does not offer (m)any valuable features for such files (no thumbnail, few tasks possible, provided parameters are irrelevant, etc.).

### Who typically uses the Products tool?

The Products tool benefits all customers that have product items coming back into production, all environments that do some form of re-runs. These sites usually are printers/converters.

If your business is to produce an item only once, then you may conclude it is not worth to add these files to the Products database. If you produce an item only once, you then probably end by removing the Job and storing its data somewhere as a backup, just in case you need it again for some unexpected reason.

### Benefits of working with Products

- Data efficiency: no more needless copying or searching of data.
- A transparent data structure that supports the process logic of re-runs.
- A more user-friendly interface: thumbnails and colors indicating status.
- Automation Engine now speaks the same language as your business system, this enables a higher form of integration, leading to even more automation.

### What is the Products tool not?

The goal of the Products tool is *not* to make Automation Engine a Digital Asset Management system (DAM).

These are some differences with a DAM:

- The Products database only stores one version. There is no automatic versioning tool.
- Searching for references is limited. You can see which Products are used in a Job and you can see in which Jobs a Product is used.
- File support: the Products tool is designed for one-up graphic production files, not for images or CAD or 3D or admin data.



**Note:** You can use WebCenter as a DAM for your graphics production data. WebCenter offers automatic versioning and supports all file formats. There are also standard available tasks to up- and download data from WebCenter to Automation Engine in case you need it (back) for production. Learn more in [Synchronizing Products with WebCenter](#), a section of the dedicated chapter [Integrating with WebCenter](#) on page 1741.

### Do I have to Install an Extra Database?

No. An installation of Automation Engine already provides the required database.



**Note:** Product attributes are stored in the same database as the one that is configured for Jobs (see **Tools > Configure > Automation Engine Database > Jobs**).

### Automated management of Products (and Jobs) via Integration

The goal of using the Products tool is to work more efficient. It is therefore important that you automate the management of your Products. Creating them manually or changing their status manually would again reduce efficiency.

You can automate managing (Jobs and) Products by integrating Automation Engine with your order management system.

These should be your goals for such automation:



- All new Jobs and Products appear automatically.
- Jobs automatically link in their Products.
- Products statuses change automatically.
- Ideally, the business system makes a difference between Prepress and Production Jobs.
- Production Jobs should be fully automatic, the Product(s) they link to are already approved so the only limitation should lie in how far you can fully automate the Step&Repeat.

See [Tasks on Products](#) to learn about tasks you can use in a Products workflow. As usual, these tasks can also be triggered from an external system. Learn more in [Integrating with External Systems](#) on page 1769.

## 8.1.2. Global Products and Job Products

A **Global Product** is the one we described [earlier](#): its data is not inside a job folder, it is independent. Global Products can be linked into several jobs (even at the same time).

It is however possible to store the data of a product *inside* a job folder. We then call it a **Job Product**, it can only be used in that job. Some Prepress Service Providers (trade shops) or commercial printers, who do not normally produce re-runs, use this concept.

Like Tickets, the global version is visualized with a yellow icon  and the job (local) version with a blue icon . See some examples in [Products Views and Menu](#) on page 605.

See this example of a Job Product, notice how the product file is located inside the job folder:

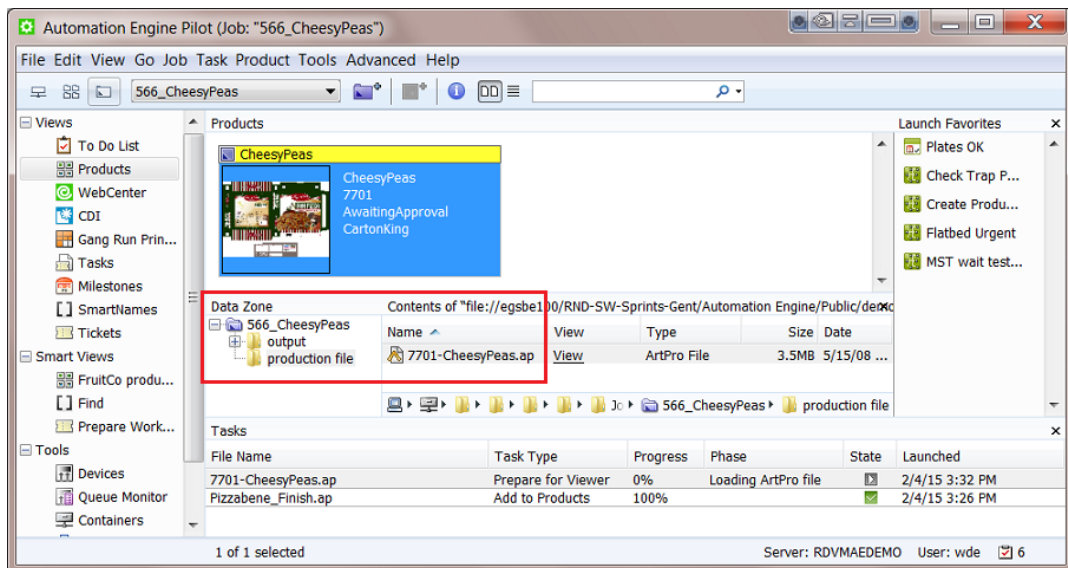

### 8.1.3. Products can have Multiple Parts

A Product can be a combination of multiple Product Parts. These parts then come together on press or later in finishing and so end up as 1 SKU in your warehouse.

Some examples:

- A bicycle helmet is sold in a plastic wrap that also contains a paper sheet with product information. The sheet was printed in 2 print runs: first the front in 2 colors (front.pdf) and then the back in 1 color (back.pdf). This front-back printing made these 2 Product Parts become 1 Product (after cutting). 1 Product is kept in the warehouse (1 SKU), 1 Product is ordered by your customer.



**Note:** There could be other Products that use the same front Part but a different back Part as their (language) variant.

- A booklet is glued to a label. These 2 Product Parts come together in finishing and so become 1 SKU, 1 Product to be ordered.



**These are Not Multiple Parts of one Product:**

At first glance, these 3 labels look like Parts of a same Product. This may look that way to the brewery, for whom the product is the beer bottle.



But, for the label printer, these are **3 different Products**.

- They do not come together in printing or in finishing.
- In the warehouse, they are 3 separate SKUs.
- They can be ordered separately: your customer can for example order 6.000 front labels, 3.000 French back labels and 3.000 Spanish back labels.

## 8.2. Products Data Structure



**Important:** This page illustrates data structures to work with *Global Products* (where the product data is not inside a job folder).

**Splitting Product data from Job data**

When jobs link to product (data) it is important that they do not share any folders. This data separation can be achieved in many ways.

Here are 2 examples:

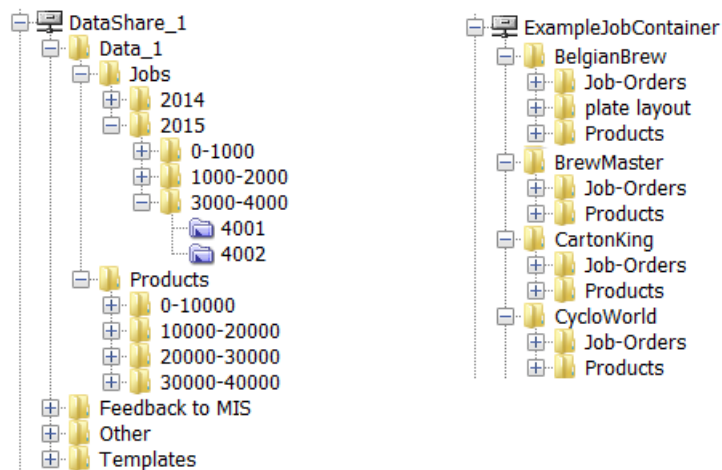

- **On the left**, an example where the data split between jobs and products happens quite high in the container.
- **On the right**, an example where this data split is done per customer.



**Note:** Using customer names for folder has its disadvantages too. Customer tend to changes names for example. Learn more about your options in [Good Practices regarding Job Folder Location](#) on page 566.

### Organization of Product data

Once your product data is split from the job data, you can freely decide how to structure that product data.

See these 2 examples:

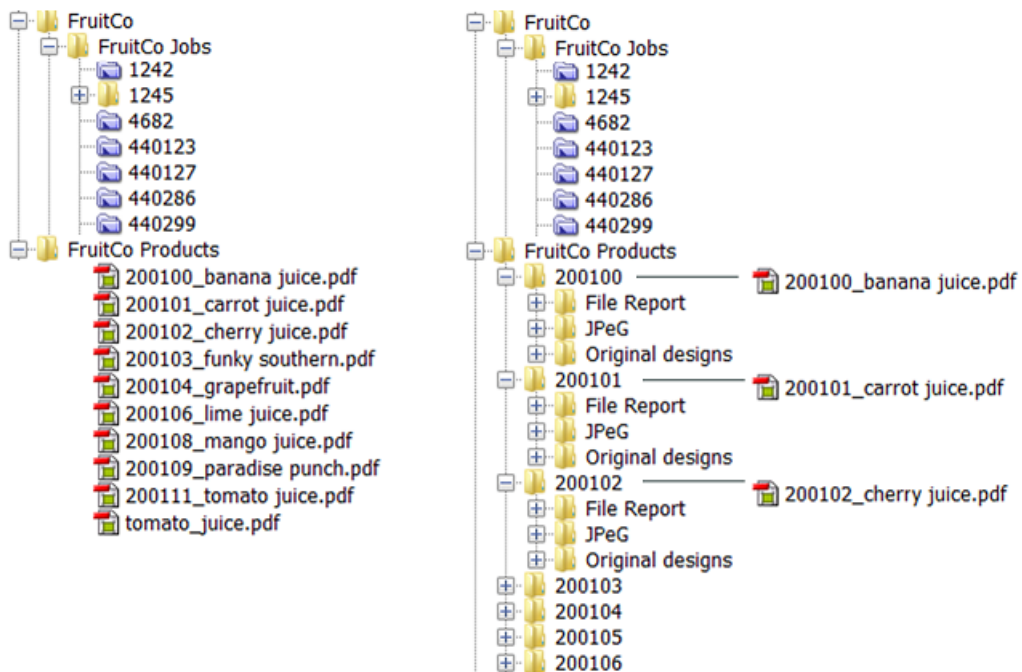

- **On the left** all the product data is in 1 same folder `FruitCo Products`. This is usually not advised because it quickly leads to having too many files in a same folder (slow browsing, general system slowness etc.). And if you want to select a file related to a product file, you will again have to browse, even when they are in subfolders like `Originals` or `Proofs`.

If you create further subfolders that avoid having too many files in one folder, then this is a valid way to organize your data.

- **On the right** each product has its own folder. This is advised. When each product has its own folder, you can
  - use subfolders to store related files.
  - choose whether you store the actual product file in its root folder (as in above example) or in its own dedicated subfolder, for example named `Production file`.



**Attention:** The more structure and consistency you have, the easier it will be for other systems to also benefit from this data structure. They can then rely on finding files in specific places and will also be able to provide you files in specific (sub)folders.



**Note:** When creating Product (Parts) via JDF, see [Products JDF setup](#) to learn about extra possibilities.

### The Product Data Zone (PDZ)

A product has one or more **Product Parts** and each part refers to a specific product part file. So when we talk about the product data we more precisely mean the product part data. Learn more in [Product \(Part\) Properties](#) on page 611.

The place where the product part file and its related files are located is also referred to as the product part **Data Zone**. In the Pilot, when working with products, you sometimes want to launch tasks on files related to that product. For example: selecting its report file and launching the E-mail task. That is why it is advised to see more data in the Pilot than just the product part file.

### The Depth of a Data Zone

The Data Zone is not just the folder where the product part file is located, it can be a larger zone. How large this zone is is decided by its **Depth**.

The reason to set this depth is to control how much data the Pilot users will see and have access to when selecting a product in the Pilot.

The depth of a product part data zone is decided when the product is created. It then takes the value as defined in **Tools > Configure > Products > Product Part Data Zone**. Learn more in [Configuring the Data Zone Depth](#).

Here are some examples:

## 8.2.1. Examples of Data Zone Depth

### Example 1: a Product Part with a Data Zone Depth of 1

The product shown below was created with a data zone depth of 1. See how, when you select the product thumbnail, the **Data Zone** pane not only shows the folder `ESKO` where the product part file is



located in, but also 30001, which is 1 folder higher. If the depth was 0, you would only see the folder Esko and so have no direct access to other product's related files.

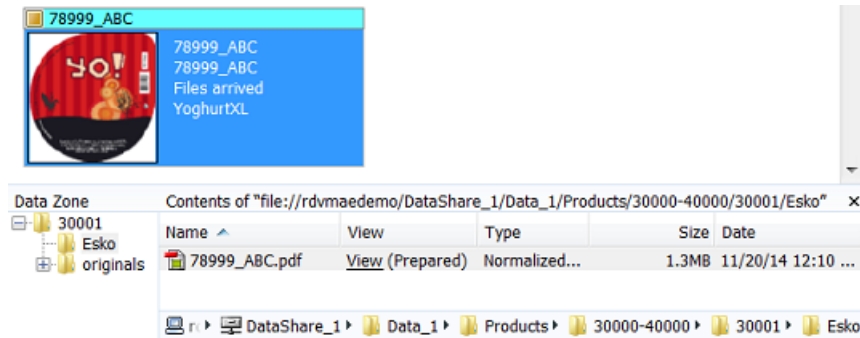

Another place where this depth is visible is in the properties of the product part. Notice how the definition of **File** in this case starts with (1) folder name:

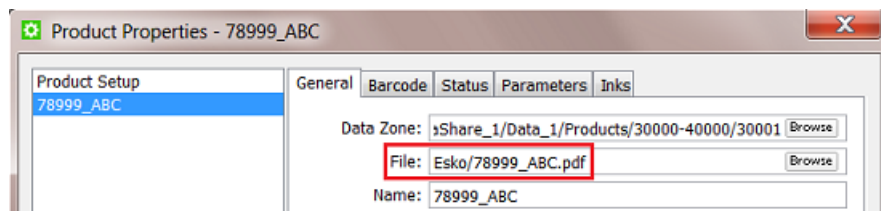

**Note:** In this properties dialog, it is possible to manually change this depth. This might be useful when a wrong depth was used at product creation time. In above case you could for example remove Esko/ from the **File** definition and it to the **Data Zone** path.

### Example 2: a Product Part with a Data Zone Depth of 0

As in the above example, the product has its own folder and subfolders. But here, the actual part file is not stored in a subfolder, but it is located in the root of that product folder. See how the PDF is in the folder 22004 :

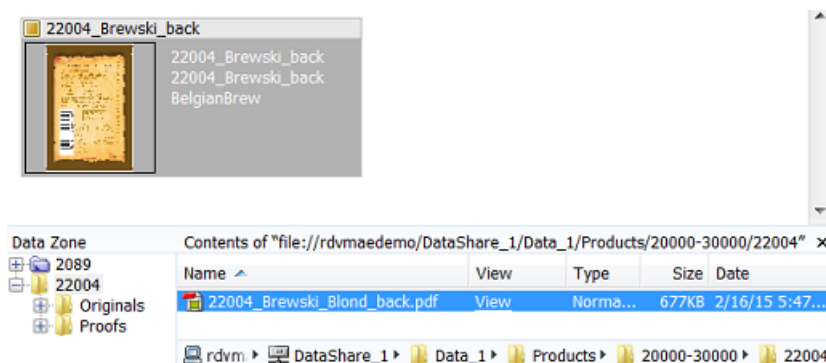

This indicates a Data Zone depth of 0. There is no need to, when you select the product, to see a folder higher than 22004.





**Note:** In the **Data Zone** pane, folders below the selected part are always visible.

In the product part setup, notice how in this case the definition of **File** only contains the name:

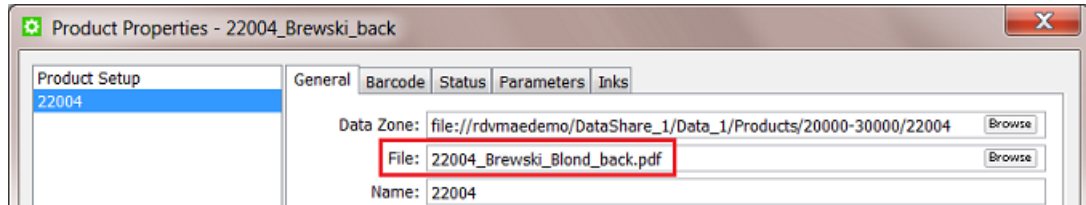

### Example 3: another Product Part with a Data Zone Depth of 0

In this example many product part files share a same folder, they do not each have their own folder and subfolders. Here's how it looks in Container mode:

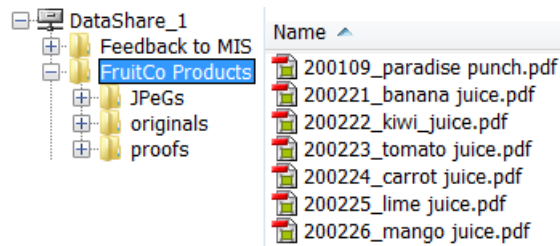

See below how, when the product thumbnail is selected, the **Data Zone** pane only shows the file's parent folder **FruitCo Products**. Also here, there is no need to see 'higher', the related files are in the folders below:

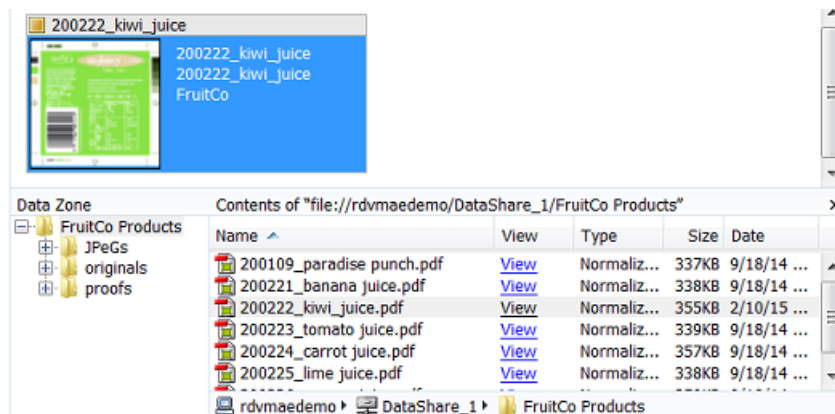

In the product part setup, the definition of **File** does not contain a folder name:

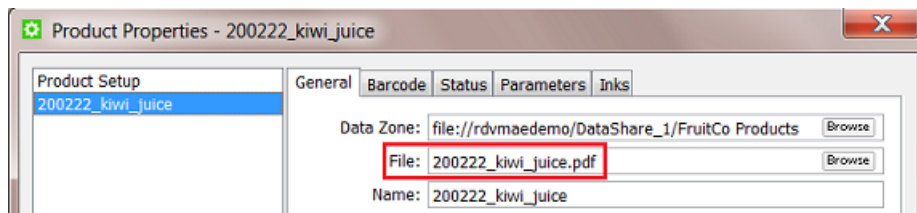

### Example 4: a Product with 2 Parts with a Data Zone Depth of 1



**Note:** Multi-part products were introduced [here](#).

This example shows a product that has 2 parts. Each product part file is stored in its own folder but they share a common root folder.

See below how, when you select a part, the **Data Zone** pane also shows 11106, which is 1 level higher than the folder the part file is located in:

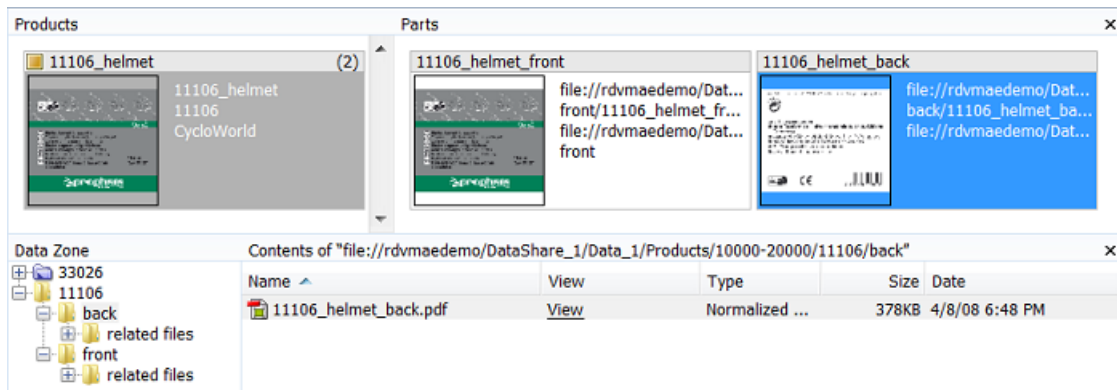

In the product part setup, the definition of **File** contains 1 folder name:

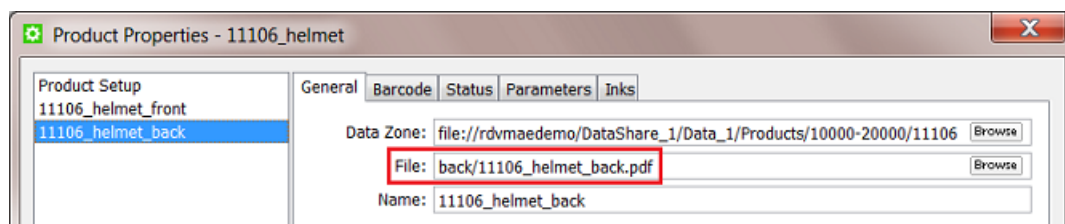

## 8.3. Products Views and Menu



**Note:** In the **Files** view you can not see if a file is a **Product Part**. Use the here described view modes to work with products:

### 8.3.1. The Products Gallery View

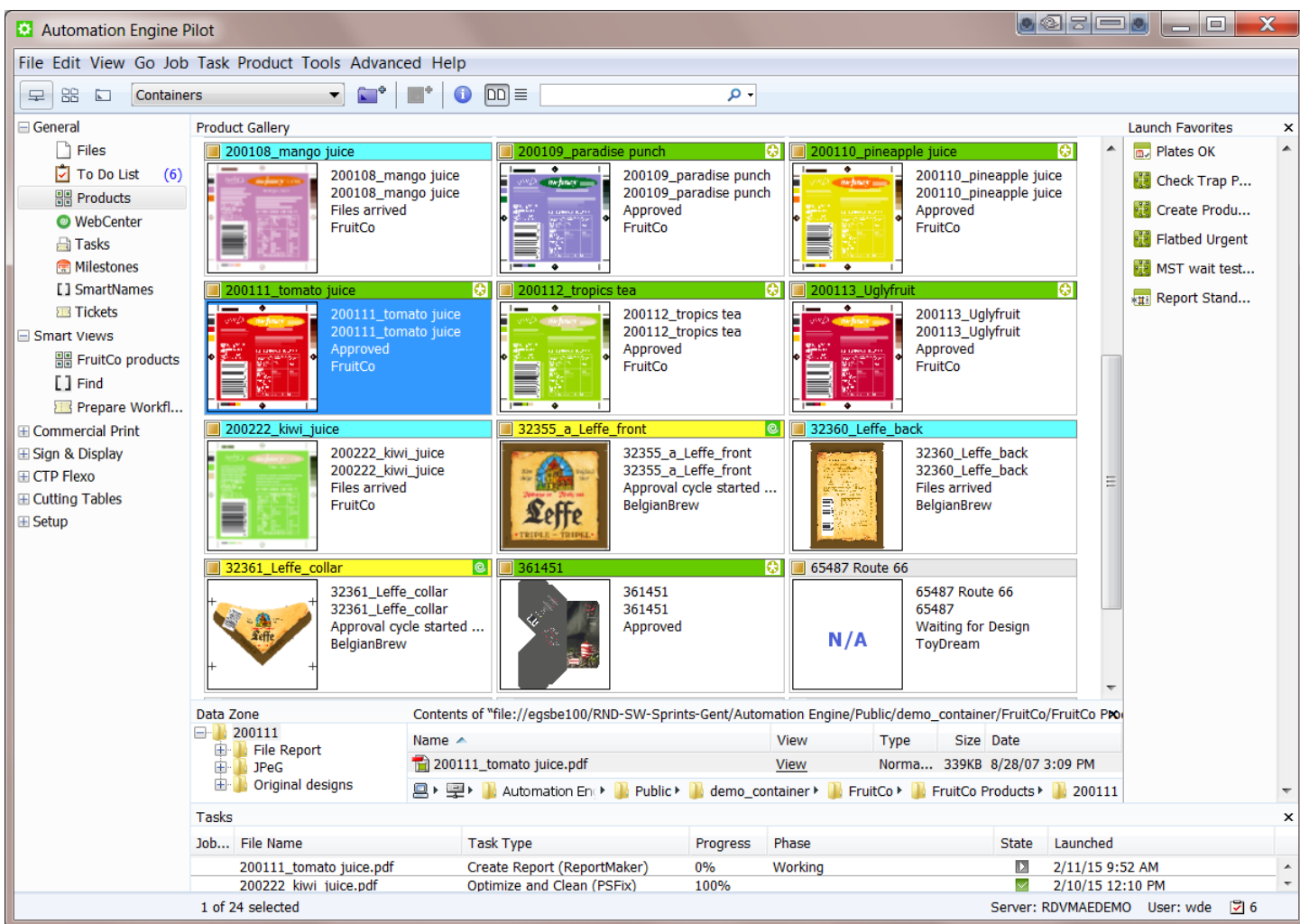

In Container mode, select the **Products** view to see

- the **Product Gallery**: a view on all or a filtered list of your Products. Choose the thumbnail view or the list view .
- the **Data Zone** pane (switch it on or off in the menu **Product**). This shows the data zone of the selected product. Learn more in [Products Data Structure](#) on page 599.

- the **Tasks** pane (switch it on or off in the menu **View**). This shows all tasks launched on any of the viewed products.
- the **Launch Favorites** pane (switch it on or off in the menu **View**). This shows your favorite tasks available for the file type of the selected product(s).



**Note:** A thumbnail mentions **N/A** when the thumbnail is not available. The reason for this can be

- because the product is an "empty" product: in JDF workflows, it is possible to create a product part that has no link to a file yet.
- because the product part file is not a supported graphics file type (as we listed [here](#)).

### The Products List View

The list view  offers the same functionality but shows the **Product Gallery** in columns:

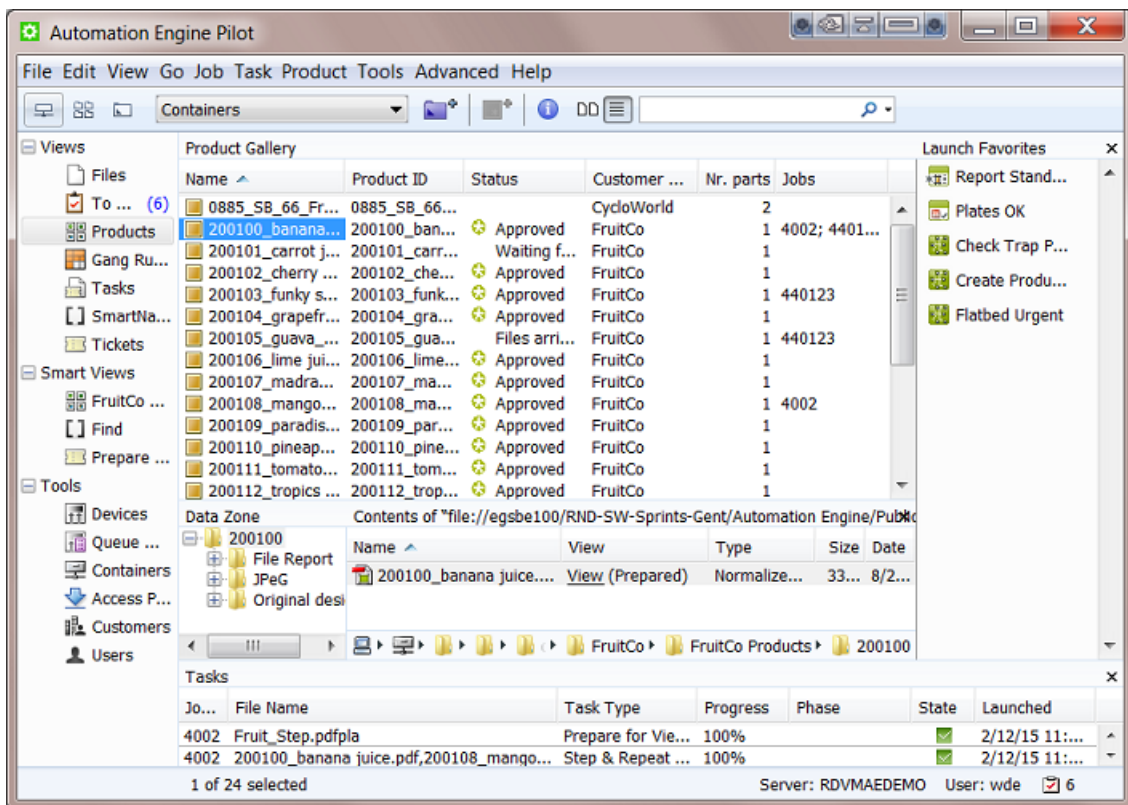

Go to **View > Select Columns in > Product Gallery...** to customize which columns you see.

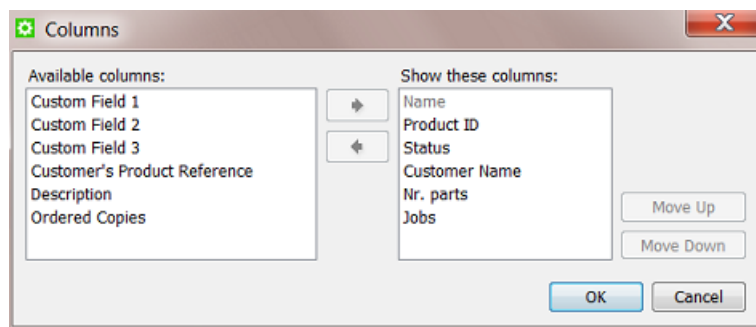

**Tip:** You can also right-click on a column title and deselect that column there.



**Note:** You can choose different columns for product parts (when also viewing the **Parts** pane).

### Working in the Gallery view



**Tip:** You can select multiple products by using Command-click (Mac) or CTRL-click (Windows) or by using SHIFT-click to select a series.

You can use the Products Gallery view to

- create a new product (📄+). Learn more in [Creating Products](#) on page 616.
- get information about products:
  - 📄 indicates a **Global Product**, 📄 a **Job Product**. Learn more [here](#).
  - To see if a product is linked to one or more jobs, you need to open the product's **Properties**. Learn more in [Product \(Part\) Properties](#) on page 611.
  - In thumbnail view, the color of the top bar indicates the status. Learn more about statuses and their colors in [Product Properties](#). When a product has multiple parts that do not have the same status, this bar will be shown in grey. Learn more about multi-part products below.
  - In thumbnail view, a number in the top right corner indicates that the product has more than one product part. Learn more below.
  - In thumbnail view, the text fields describe the main product attributes. Use **View > Select Thumbnail info in > Product Gallery...** to customize the information that is shown there.
- manually change product properties. Press ⓘ or right-click the product(s) and choose **Product Properties...** Learn more in [Product \(Part\) Properties](#) on page 611.
- launch tasks on one or multiple products. Select the product(s), choose a favorite ticket or right-click and choose **New Task** or **Launch with**.



**Note:** A task that you launch on a product part that is linked to a job will run in the context of that job. This is important when you use job related SmartNames in the task's ticket(s).



**Note:** If a product is linked to more than one job, the task will run in the context of the job that this product was most recently linked to. Learn more in [Product Setup](#) on page 612.

### Viewing Multiple Parts

When you select a product that has more than 1 part, an extra pane opens that shows those parts. This happens automatically when you activated the function 'Show Parts' from the menu **Products**.

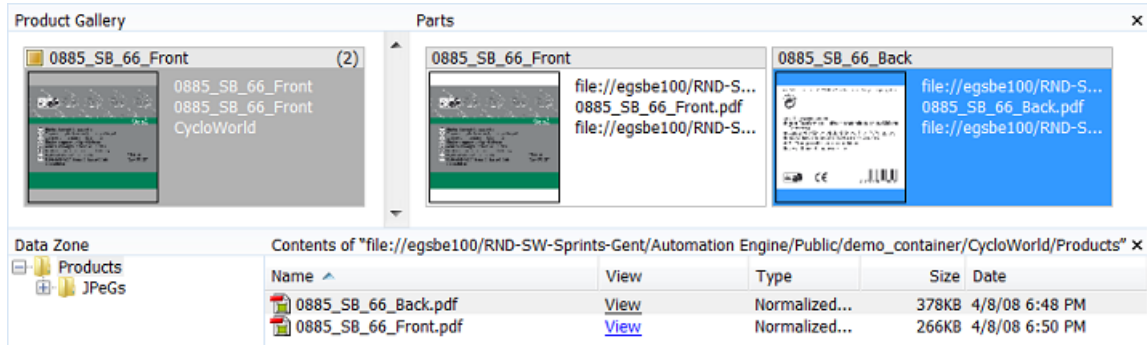

**Tip:** You can re-size this **Parts** pane, the Pilot will remember its size.



**Note:** In the **Data Zone** pane, the file(s) representing the selected product part(s) will be highlighted in grey (and vice versa).



**Note:** The name of the main product thumbnail is the name of the first product part (as defined in its properties). Learn more [here](#).



**Note:** The thumbnail info of a product part can be different than for the main product thumbnail. Set this info in **View > Select Thumbnail info in > Parts...**

By seeing the separate parts, you have all the above mentioned functionality also available on product parts.

If however you want the functionality (a task or managing properties) to happen on all parts, then there is no need to view or select any parts. For example launching a task on the main product thumbnail will automatically launch this task on all parts.

### Filtering and Searching

The filter and search tools enable to quickly make smart product selections. You can also save these filters as a [Smart View](#).

You can search and filter products in the same way as you do with Jobs. Learn more in [Job View Filters](#) on page 542.

### More Functionality in this View

A lot of functionality is offered when you right-click one or multiple products:

- Use **New Task** and **Launch with...** to launch a task or workflow on your selected product(s). Learn more in [Launching a Workflow on a File](#) on page 781.
- Use **Open...**, **Open With** and **View...** to open the product part file in a chosen application or in the Automation Engine Viewer.
- Use **File Info...** to see the metadata of the product part file.



- All other features are described in [The Product Menu](#) on page 610.

### 8.3.2. The Product(s) in a Job View

When in **Last Used Job** mode, the **Products** view shows which products are linked into that job.

When this job is a "prepress job", your goal will be to get that product approved and ready for output. When this job is a "production job", you will probably work on step & repeat (in an editor or via tasks) and/or output tasks. Learn more about these job types in [Types of Jobs](#) on page 539.

See this an example of a production job that needs to output 2 labels:

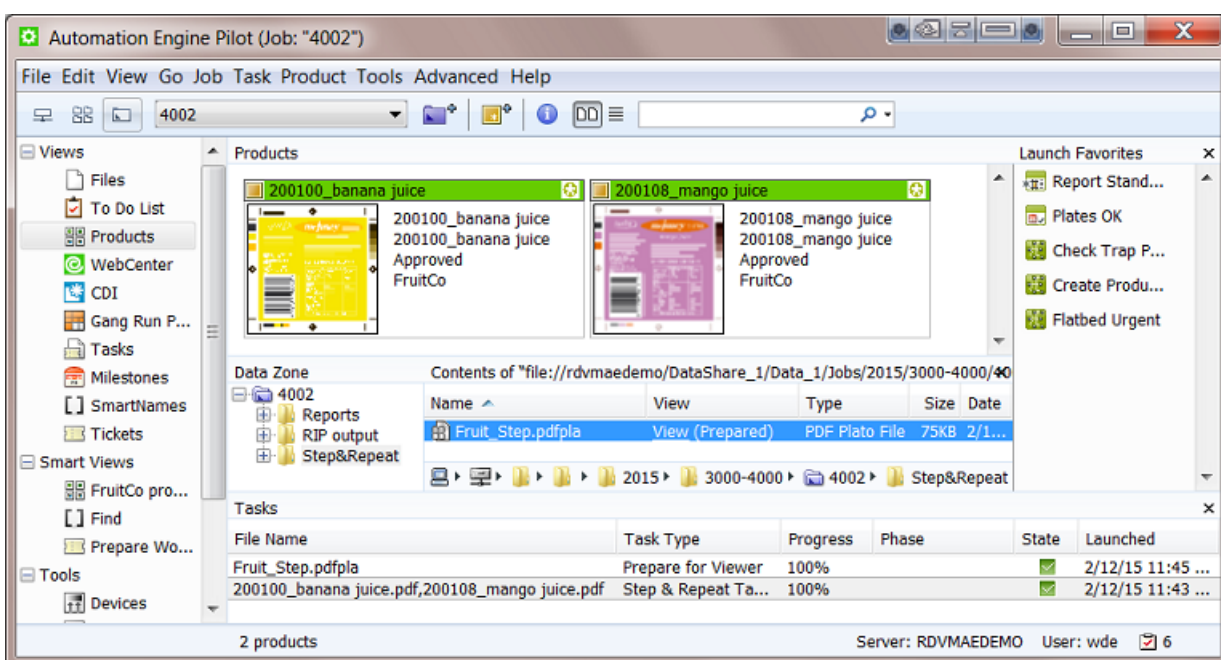

Notice how

- the 2 products have a status 'approved', which is typical when you start outputting them.
- a Step & Repeat task was launched on the 2 products.
- the resulting pdfpla file was output in the job's subfolder "Step&Repeat".
- that pdfpla file was selected to launch the **Prepare for Viewer** task.

#### Using the Data Zone pane to see All Related Data

In job mode, the **Data Zone** pane always shows the job folder. When a product is selected, you will also see the product's data zone.

In this example, selecting the 'mango' product made the **Data Zone** pane also show folder '200108' and its subfolders:

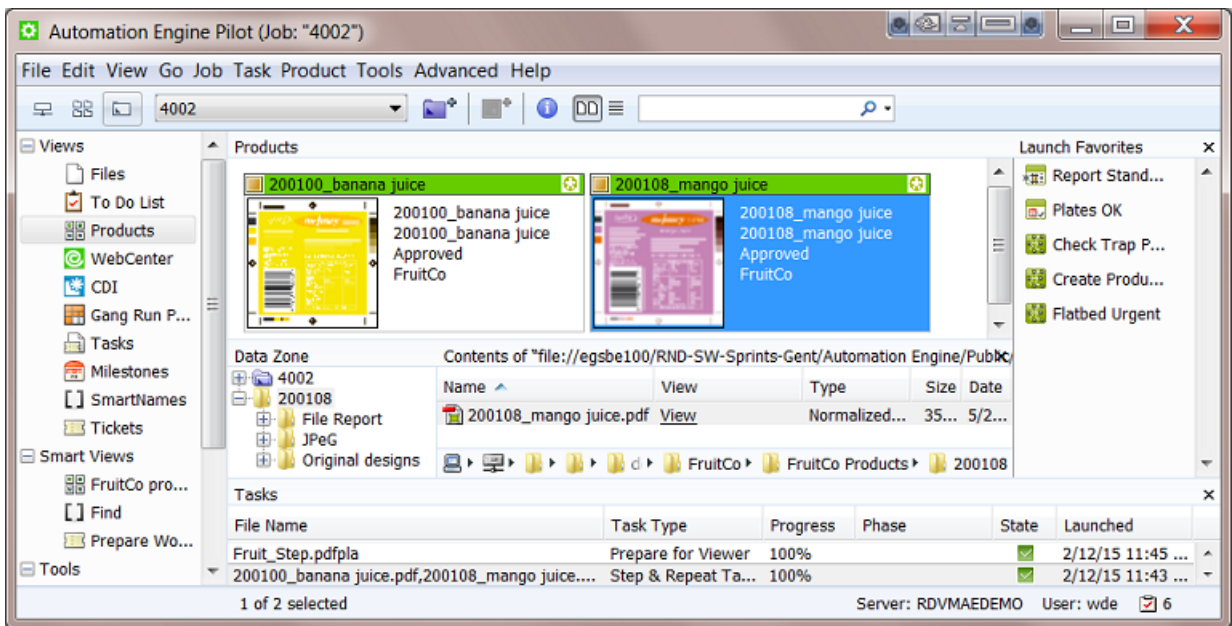

**Note:** The data zone of a product is decided at its creation time. Learn more in [Products Data Structure](#) on page 599.

In job mode, the **Data Zone** pane offers access to all the data relevant for that job:

- When you want to access a file in the job folder, browse to it in the (blue) job folder.
- When you want to access a product part file, click on the product part thumbnail and choose your action from there.
- When you want to access another file in the product's data zone, select the product part thumbnail to visualize its data zone and then browse in those (yellow) product folder(s).

### Hiding the Files View

The fact that you can access all data using the **Data Zone** pane, means that there is no more need to see the **Files** view (when you work with products).

Also, when you use the **Products** view and then switch to another job, the **Files** view will again be shown. To avoid that you need to click on the **Products** view again, you can choose to hide the **Files** View.

To do this, right-click on the **Files** view and choose **Remove from Views Bar**.



**Tip:** To see the **Job Setup** while staying in the **Products** view, select the blue job folder icon and use the shortcut CTRL-ALT-J (Windows) or Command-Alt-J (Mac).

### 8.3.3. The Product Menu



**Tip:** Many of the features offered in the **Product** menu are also offered when you right-click on a selection that you made.



- **New Product...** allows you to browse to a file, create it as a product and link it to the job you are in. Learn more in [Creating Products Manually](#) on page 616.
- **Upload as Product...** does the same as above but also uploads the chosen file to its new product data zone. You can use this for example when the file is still on your local computer, on a CD/DVD drive or already in a Container but not yet in its proper product place. Learn more in [Uploading As a New Product](#) on page 617.



**Note:** These features are also available when you right-click on an empty piece of canvas in the Product Gallery.

- **Link Products....** Use this feature to manually link product(s) to the job you are in.
- **Product Properties...** opens the setup of the product and its parts. Learn more in [Product \(Part\) Properties](#) on page 611.
- **Go To File** shows you the product part file in the **Files** view of the **Container** mode.
- **Explore Folder...** opens a disk explorer view of the folder of the selected product part file.
- **Link to Job...** enables a quick way you to link a product(s) to a job from a list of most recent used jobs (or choose **Select Job...** to select any other). You will get a warning when the product is already linked to that job.
- **Unlink Product.** In **Job** mode, use this to remove the selected product(s) from that job. This does not delete any files.
- **Hide / Show Parts.** Learn more in [the Products Gallery View](#) about working with Products that have **Parts**.
- **Manage Product Filters....** If you saved filters in your **Products** view, manage them here and decide if you want to add them in the **Views** bar (as a **Smart View**).
- **Manage Statuses....** This is where you can add or modify custom product statuses. This list also contains **Milestone** names that were allowed to be used as product status. The way to add or modify them is the same as described in [Manage \(Custom\) Milestones](#) on page 574.

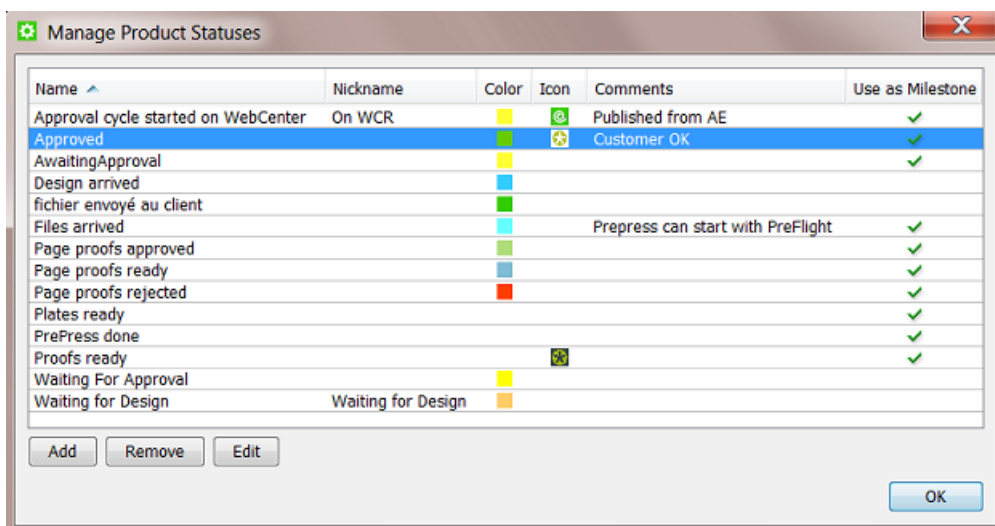

## 8.4. Product (Part) Properties

Product properties are the attributes that are stored in the Automation Engine Products database.

The concept is very similar to the **Job Setup** fields for Jobs. Most of the properties also become available as SmartNames, in a dedicated category **Product Information**. Learn more on how to use SmartNames [here](#).



**Note:** The **SmartNames** view allows to specifically test product part SmartNames. Learn more in [Also Show Product \(Part\) Parameter SmartNames](#) on page 654.

The properties are divided in general product properties ([Product Setup](#)) and properties specific to each product part ([Product Part Setup](#)).



**Note:** The concept of multi-part products was introduced [here](#).

You can also use the **Product Properties** dialog to manually **Add** or **Remove Parts**. You can use the arrow buttons to sort the parts. A product will get its name and thumbnail from the product part that is highest in this list.

### 8.4.1. Product Setup

#### General tab

The screenshot shows a dialog box titled "Product Properties - 600\_banana juice". On the left, there is a "Product Setup" list containing "600\_banana juice". The main area has three tabs: "General", "Jobs", and "Parameters". The "General" tab is selected and contains the following fields:

- Name: 600\_banana juice
- Product ID: 600\_banana juice
- Customer Name: Fruit Co (with a "Select..." button)
- Customer Reference: 2021\_09\_23 ban
- Location: Canada (dropdown menu)
- Custom Field 1: Flexo (dropdown menu, with "Manage..." button)
- Custom Field 2: English-French (dropdown menu, with "Manage..." button)
- Custom Field 3: (empty dropdown menu, with "Manage..." button)
- Description: new design summer 2021 corona edition
- Order Material: Film Medium 03 (with a "Select..." button)
- Status: Approved (dropdown menu)

At the bottom right, there are "OK" and "Cancel" buttons.

- **Name:** For global products, the product name has to be unique. For job products, the name has to be unique within a job. For example there can be multiple job products with the same product name as long as they exist in different jobs. Learn more about global and job products [here](#).
- **Product ID:** This is the product identification code, often (only) a number. The same remark as mentioned above about uniqueness is also valid here. The maximum length of a product ID is 32 characters.
- **Customer Name:** Select the customer that this product belongs to.

- **Customer's Product Reference:** This is the name your customer uses for this product. It can be useful as a search filter or for example to mention on a report file for this customer.
- **Location:** An attribute used for data filtering in My Workspace. Learn more in [Locations](#) on page 220. When you type in this field or use a SmartName, make sure the value matches exactly to the name of an existing location (case-sensitive!). When this is not the case, the task will create a new location.
- **Custom Fields:** You can define up to three custom fields to help you search the products database or to use them as SmartNames.
- **Description:** You can add a description (maximum 128 characters).
- **Order Material:**

An **Order Material** is the material that your customer wants a **Product** to be printed on. It's the name of the material as your customer understands it and probably also the name he used when he was ordering the production job. This name is the name of that material as it is mentioned on the job order.



**Note:** It is possible that you internally use another name for this material, but in Automation Engine (the browser client used in the QuickStart deployment), we refer to that one as the (real) 'Print Material'.

You can select it from the list that shows those you also see in the View [Order Materials](#).



**Note:** When you type in a name of a material that does not exist yet, it will be seen as a new one and created.

- **Status:** Choose the products status from the list. Learn about standard and custom statuses in [The Product Menu](#) on page 610.



**Tip:** You can use the [Wait for Product Status](#) task to hold and continue a workflow based on this status.

### Jobs tab

This is where you see which job(s) that this product is currently linked to, and when that link was made.

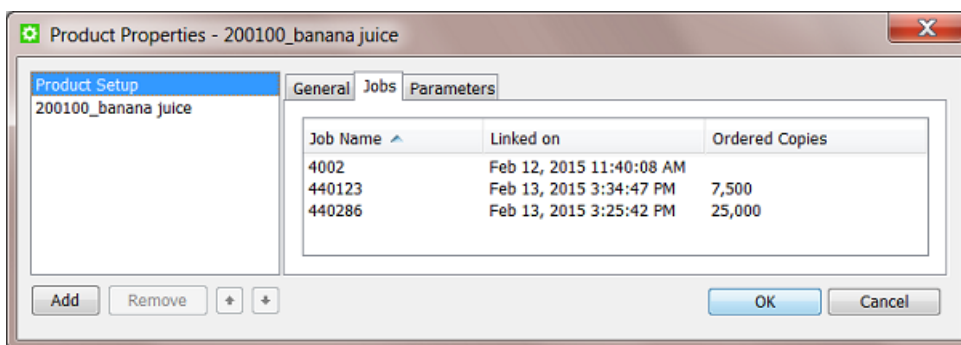

**Attention:** If the product is linked to more than one job, a task that is launched on that product will run in the context of the job that this product part was most recently linked to.

**Ordered Copies** is an attribute that can be set when you use the [Task 'Link Product to Job'](#) on page 628. This number is picked up in the **SmartLayout** function of Esko's Step & Repeat editor **Plato** (learn more in [Working with Products in Editors](#) on page 623). This number also becomes a SmartName that for example can add its value to a report file.

### Parameters tab

You can here add custom parameters that also become available as SmartNames.

When you have long lists of parameters, use the search field to quickly find parameters based on their **Name** or **Value**.



**Attention:** Mind that these parameters need to reflect what is specific for this product (range). Parameters that relate to how you *output* this product (Step&Repeat, press...) are probably more job related parameters and so belong in the job setup.

## 8.4.2. Product Part Setup

You can specify more and different properties for a product part because

- a part refers to a file. Some part properties relate to the file's location and its graphics characteristics.
- a product can have several parts with different properties (for example the front has the barcode and the back only has one ink).

Most properties also become available as SmartNames (in the category **Product Information**).

See this example of a product with 2 parts:

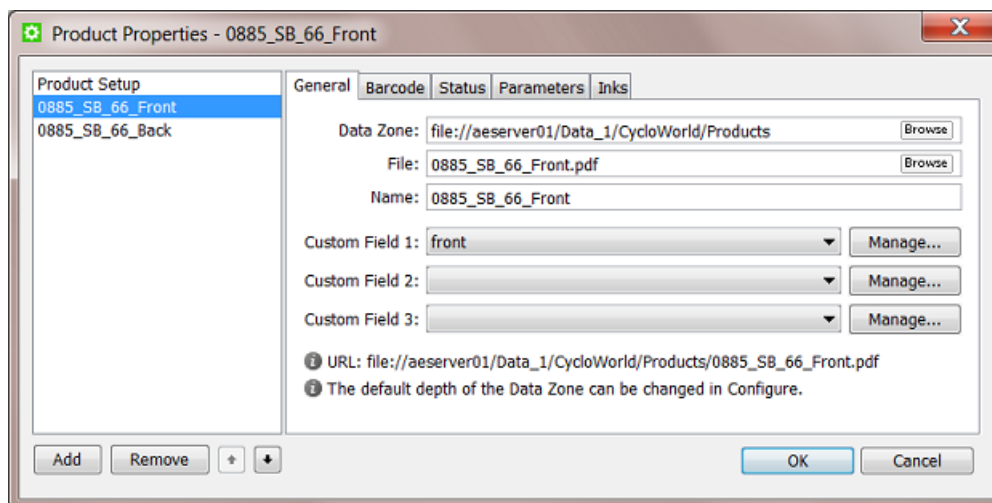

### General tab

- **Data Zone:** This is the path to the folder containing the product part. This could also be a folder one or more levels higher. Learn more about the important concept **Data Zone** in [Products Data Structure](#) on page 599.
- **File:** This is the name of the file for that product part.



**Note:** If the parts file is in a subfolder within the parts data zone, you can include a folder name in this field: `subfoldername/file`. Learn more in [Products Data Structure](#) on page 599.

- **Name:** This is the name of the product part. This can be different than the file name.
- **Custom Fields:** You can add up to 3 custom fields.

### Barcode tab

If the product part file has an (Esko) barcode, you can specify its properties here. The barcode can be checked and corrected using the [interaction with Esko editors](#) or by using the task [Check Product Parameters \(Classic\)](#). The details and usage is identical as with jobs: learn more in [the Job Setup Barcodes tab](#).

### Status tab

Each product part can have its own status. This is relevant when a product has multiple parts.



**Note:** A product will automatically get the status of its parts when there is only one part or when the status of all its parts is the same.

The set a status, pick it from the list or use the task [Manage Product Status](#). If the status you choose has a **Nickname**, than that is the name you will see. Learn more about creating statuses in [The Product Menu](#) on page 610.

You see when and by whom the status of this product part was last changed. An extra note can also help clarify why the status was changed.



**Tip:** When the change was done by the task [Manage Product Status](#), the user name includes the name of the server.

### Parameters tab

You can set custom parameters per product part. Their SmartName version shows up in the category **Product Part Parameters** and their name starts with `[ppp. ]`.

When you have long lists of parameters, use the search field to quickly find parameters based on their **Name** or **Value**.

### Inks tab

The inks in the product part file can be checked and corrected by the [interaction with Esko editors](#) or by using the [Check Product Parameters \(Classic\)](#) task. Details and usage is identical as with jobs, learn more in [the Job Setup Inks tab](#).



**Note:** JDF workflows that create product (parts) can also specify such ink properties.

## 8.5. Creating Products

---

Products can be created

- manually, using the Pilot
  - by making a file a product part file
  - by uploading a file to a new place and then making that file a product part file.
- automatically
  - by using the task [Add to Products](#). The task then defines the product properties based on the file's URL or metadata or out of some XML file(s) etc.
  - by direct JDF/JMF commands. This technique communicates directly to the server software. For more information on JDF contact Esko Solution Services or find some basic answers in the chapter [Integrating with External Systems](#) on page 1769.



**Note:** You can also use above tools to modify products (except the upload method).



**Note:** Removing products is described [in this separate page](#).

### 8.5.1. Creating Products Manually



**Note:** Learn about the difference between global and job products [here](#).

#### Creating a Global Product

Follow these steps to manually create a new product:

1. In the Pilot, go to **Container** mode and **Products** view and click on . Alternatively, go to **Product** > **New Product...** or right-click on an empty part of the canvas in the **Product Gallery** pane and choose **New Product...**
2. The dialog first asks you to select the file that you want to add as product part file. Make your selection and click **OK** to continue.



**Important:** When you select multiple files, the next steps will create them as parts of a same product.



**Important:** If you select a file that is located in an (active) job folder, you will automatically create a job product.

3. Now define the product's properties, both of the product and of the product part(s). Learn more in [Product \(Part\) Properties](#) on page 611.



**Tip:** At this point, you can use the **Add** button to add extra product parts.

4. Click **OK** to confirm and create the product. The new product appears in the product gallery.



**Note:** You will get a warning when a product part with the same name or ID already exists.

### Creating a Job Product

To create a job product, you can use the same steps as above but you start in **Last Used Job** mode (you are in a job and you select a file located somewhere in that job folder).

## 8.5.2. Uploading As a New Product

**Upload as Product...** does the same as creating a new product but also uploads the selected file to its new product data zone.

You can use this for example when the file is still on your local computer, on a CD/DVD drive or already in a Container but not yet in its correct product place.

Much like [Creating Products Manually](#), follow these steps to upload one or multiple file(s) as a new product (parts):

1. In **Container** or **Last used Job** mode, go to the menu **Product > Upload as Product...** or right-click on an empty part of the canvas in the **Product Gallery** pane and choose **Upload as Product...**
2. Select the file(s) and fill in their properties (same steps as when [Creating Products Manually](#) on page 616).
3. In the product part setup, there is now one extra field where you have to define the **Destination** of the file. Choose the **Use the Smart Product Location as set in Configure** or browse to where you want to store the product part.

The **Smart Product Location** is a tool that can define the location and name of the product part based on a product parameter or on the default location for that customer. Learn more in [Smart Product Location](#) on page 238.



**Note:** The **Smart Product Location** can be checked by clicking on **Show Product Location**.

4. Confirm with **OK**.

## 8.5.3. Creating Products Automatically

You can create products automatically by using the [Task 'Add to Products'](#) on page 626.

You can launch this task

- as a user in the Pilot, after selecting an input file. This is advised when you use a task ticket in which SmartNames already fill in many properties automatically.
- or this task can be part of a workflow that selects the input file(s) and also provides the values for the required product properties.

To automate the creation of products, you typically create workflows that combine the task [Add to Products](#) with some of these tools:

- the [Select File](#) and the [Select Referenced File](#) workflow control (when the file path is mentioned in an XML or CSV).
- [Using Regular Expressions](#).
- the [Data SPlitter](#) workflow control.
- **System Value SmartNames**. Learn more in [Creating System Value SmartNames](#) on page 667 and see an [Example of Looking for the Product Part URL](#) on page 669.

Some of these are used in these examples of the two main types of product creating workflows:

### Example Workflow 1: Building your Products Database from your Existing Data

When you start to work with the products tool, you may already have a lot of data that you want to add to your products database. With this existing data, your goal is to launch workflows that create many dozens or hundreds of products in one go.



**Attention:** Based on what you learned in [Products Data Structure](#), you can decide to first re-arrange your data structure or to keep the data in their existing folders before you start creating your products.



**Tip:** It is good practise to first test this import on a part of your data, for example limited to one of your customers. We advise to also test your output workflows with some of that first set of products. You might learn details that you want to change before importing all your other products.

See this example where all the 200\* folders contain one product part file in their root folder:

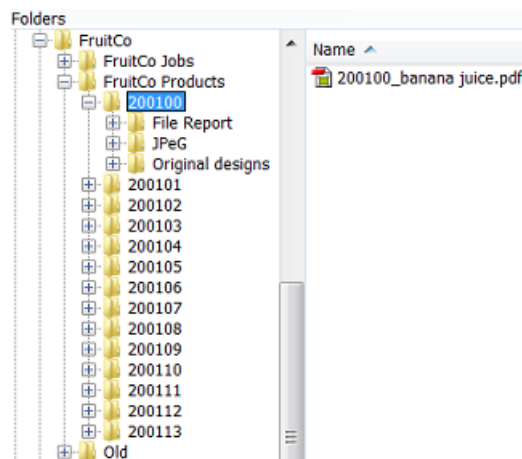

This is the workflow we will use to automate creating these products:



We first use a smart way to select only the part file we need. We then add it as a product. We then set the status.



These are important steps and settings in this workflow:

1. First manually select all the 200\* folders and then launch or open your workflow.
2. The **Data splitter** (default settings) will split that group of folders and will so launch the **Select File** step on every separate folder.
3. In **Select File**, use these settings:

- **File Type:** in this example the type we want is a normalized PDF.
  - In **Select other Files**, we select all those that are in the URL of what this step received as input: that (single) 200 . . . - folder.
  - Do not **Look in subfolders** to avoid selecting the other PDFs or any report files.
4. In the **Add to Products** task, make sure to indicate the customer. We know the customer because we make a manual selection under the product folders of a specific customer.



**Tip:** When you do not set the customer via a SmartName, this workflow ticket becomes customer specific. In such cases we advise to add that customer name to the name of your workflow ticket.

5. We propose to already set a status. When these data were produced earlier, you can for example set their status to 'Approved'.



**Tip:** When you are testing these workflows, make sure to check the **Updating** options in the **Add to Products** task.

## Example Workflow 2: Adding New Incoming Designs as Products

### When Should a New Design become a Product?

The concept of products allows to add them to the database very early. As soon as you have a representation, a new design, you can add this file as a product part.

You can use the product status to indicate what stage this product is in, for example `New` or `Preflight OK` or `Waiting for Approval` etc.

### Changing the Product Part File During Prepress Stages

You can also change the product part file during a workflow. For example you first use the design file as the product part file but once you import or normalize or start editing you then move that original design file to a subfolder `original` and update the product part with the more recent (normalized) PDF file.



**Note:** To update a product you use the same **Add to Products** task but use specific settings in its **Updating** tab.

### Creating a Product in a Job Context or Not

It is your choice to add the product while you are in a job context (in Last Used Job mode) or not (in Container mode).

As mentioned in the page on [Types of Jobs](#), when you do not work in a job context, it will be difficult to give feedback to your business system. However, many such systems do not give you a job-order number to do prepress work on new designs. Many of them only send you job numbers for 'production jobs' in which you output already approved products.

In that case, you still have a choice to create your own 'prepress jobs'. A reason to do that is consistency, because then everything that your users do in prepress (with Automation Engine) happens in a job context.



**Tip:** But how do you name those self-created prepress jobs? You could base their name on the name of the product they are supposed to create. For example if you know you are preparing a new product that should be named `7890`, then you could do this work in a job named `Preparing_7890`.

### Avoid Changing a Product Name or ID: Get it Right from the Start

It is very important to get the product name and ID as soon as possible. You do not want to create a product and later change its name or ID. If this name is not sync with what the business system expects then there will be no or little integration possible. For example if you send the business system an early JPEG of the new design, it will need to have the correct name: the name of the item that this system expects.

In an ideal situation, your business system sends you a [prepress job](#) and in there mentions the name and ID of the product that it expects you to create.

In all other cases, to get this correct product name or ID, you will probably need to get this information from people working with the business system. It is in that admin department that this number was created. In the business process, those colleagues made the decision that you should prepare and output a new design or variant, so they will have a record of that item number (and name).

### Example Workflow

Your new designs can come in via many different ways. An important tool to help automate creating them as a product are [Access Points](#). An Access Point can detect a new incoming design and immediately launch a workflow that moves the file to the right folder for the product part and then adds it to the product database.

See this example:

- A **Folder Access Point** detects new designs coming in from the customer `FruitCo`.

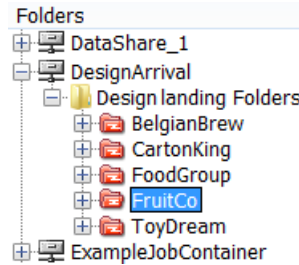

- This access point launches this workflow:



1. The found data is moved away from the access point folder to an 'arrival hall' for new designs for this customer:

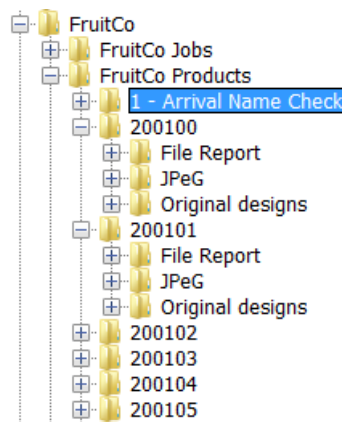

**Important:** We use this intermediate place because we first want to check what the correct name and ID for this product will be.

2. The **CheckPoint** task asks a user to check with the admin department what the correct name and ID needs to be. When needed, the user manually changes the name of that design file.
3. The next **Move** task is now able to move the design to a new own product folder. The folder is decided by using SmartNames, based on the customer name and on the first 6 characters of the designs name.
4. Now that we have the file in the right place and with the right name, we create the product.
5. A preflight is executed on the file.
6. The status we set depends on the preflight result.



**Note:** You can of course extend this workflow with steps like editing and proofing. The goal of this 'prepress job' is to have an approved product item. An other job should then serve to output this product, possibly together with others.



**Note:** There are countless variations of how new designs can be processed. To create smart ways of automating their import to the products database, we advise to study all the possible tools mentioned in [Creating Products Automatically](#) on page 617.

### 8.5.4. Creating Products via JDF/JMF

Products can also be created via XML or JDF/JMF.

Learn more in the chapter [Integrating with External Systems](#) on page 1769.

## 8.6. Linking Products to a Job

---

A global product can be linked to one or multiple jobs. A job product can only be linked to one job.

You can link a product to a job

- manually, using the Pilot, in **Products** view,
  - in **Container** mode, by right-clicking one or multiple products, choosing **Link to Job** and selecting the job from the list of recently used jobs (or by using the dedicated menu item).
  - in **Last used Job** mode, by right-clicking in the **Products** panel, choosing **Link Products...** and selecting the one(s) you want (or by using the dedicated menu item).
  - in **Last used Job** mode, in the **Data Zone** panel, by selecting a file in the job (sub)folder and choosing the menu item **Product > New Product....** This will create a job product and automatically link it to this job.
- automatically,
  - by using the task [Link Product to Job](#).
  - by using JDF/JMF commands. This technique communicates directly to the server software. For more information on JDF contact Esko Solution Services or find some basic answers in the chapter [Integrating with External Systems](#) on page 1769.

#### Which Job(s) is this Product Linked To?

You can see the job(s) that a product is linked to

- in the product's properties. Learn more in [Product Setup](#).
- in ☰ the list view. Learn more in [Products Views and Menu](#) on page 605.

#### Which Product(s) does this Job Link to?

You can only see which products a job links to by opening the job in **Last Used Job** mode.

## 8.7. Launching Tasks on Products

Launching tasks on products is very similar to launching tasks on files.

Here is some information specific to launching tasks on products:

- As with files, you can right-click on products and launch tasks from there. You can also launch **Favorites**.
- Launching a task on a product will launch it on all its product parts. If you want to launch a task on a specific part, use [Show Parts](#) to see the **Parts** panel and make your specific selection there.
- In **Last used Job** mode, in **Products** view, when you select one or more products and launch a task, it will run in the context of that job. The SmartNames will relate to that job.
- In **Container** mode,
  - tasks launched on products check if those products are linked to a job and will run in the context of that job. See an example where two products were selected and the ReportMaker task was launched:

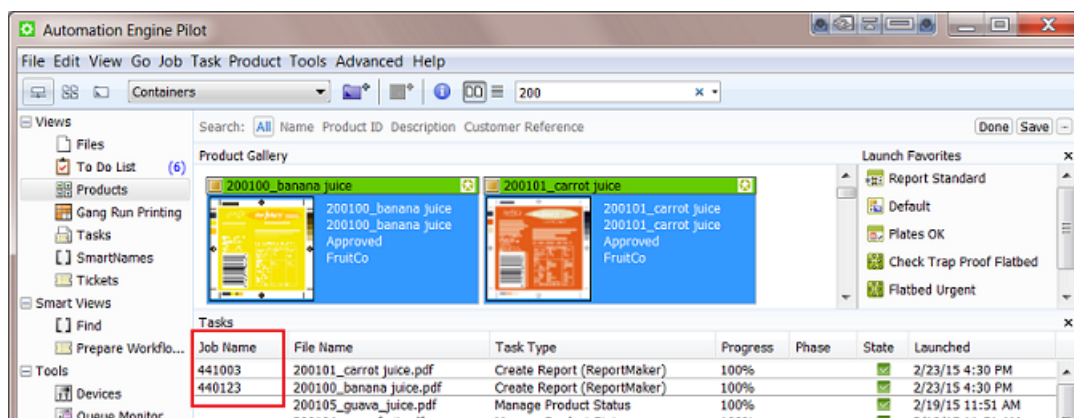

- when a product is linked to multiple jobs, the task will run in the context of the job that the product was last linked to. Learn more in the [Product Setup](#) on page 612.
- In a workflow, you can use the [Select File](#) step to select all the product parts of the job (context) that that workflow is running in. The next workflow step is then launched on those product parts.

## 8.8. Working with Products in Editors

Editors that have been configured to be a client of your Automation Engine server, will show extra tools that help you work with products.

### Easy Access to Open Products in Editors

Esko editors like ArtPro+ and the classic editors ArtPro, PackEdge and Plato can communicate with an Automation Engine server. This also enables an easy way to open product part files.

In their **Open** dialog, extra **Job** and **Product** lists help avoid a lot of browsing:

- You can select a job first and then the products linked in that job appear in the list of products:

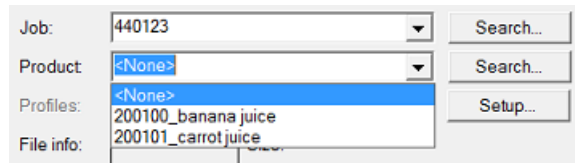

- You can press **Search...** to open a dedicated **Select Job** or **Select Product** dialog.
- You can click on the drop-down arrow to pick one from the memory of last used jobs or products.
- When you open a product that has multiple parts, an extra dialog will open to let you choose which part you want to open.



**Tip:** When you are editing a product and you want to update it with your changes, then you best use **Save** and not **Save as**. Saving as another name and/or in another folder will not change the product part's URL.

### Editors Checking a Product's Barcode and Ink Parameters

As mentioned in the chapter on [Jobs](#), Esko editors check if the file's barcode and ink settings match those that were defined in the file's job setup (in [Job Ink parameters](#) and [Job Barcode parameters](#)).

The same principle and tools are valid when your editor opens a product part file that has properties for barcode and/or inks.



**Note:** When both the file's product part and the file's job have such parameters defined, then the product part parameters are checked.



**Note:** When an editor is checking product parameters, the dialogs use the same wording: they also mention "Check *Job* Parameters" when they check *product* parameters.

And, as with job parameters, there is also a dedicated task to check or correct such product parameters. Learn more in the [Check Product Parameters \(Classic\)](#) task.

### In Esko Plato: Fast Ways to Load Products onto a Layout

Esko's Step & Repeat editor Plato offers extra tools that also avoid searching and browsing when you put **stations** on the layout.

For this to work, Plato first needs to be aware in which job you are working. This is done in the **Layout Setup** dialog:

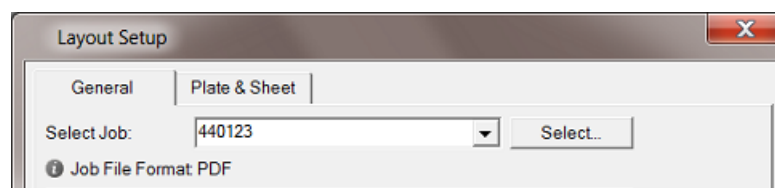

- When you create a **Manual Layout**, the dialog **Place Station** offers the same job and products lists as in the **Open** dialog, as shown above.
- When you create a new grid based layout, your right-click to add a station now also offers to add the product parts (that are linked in that job):

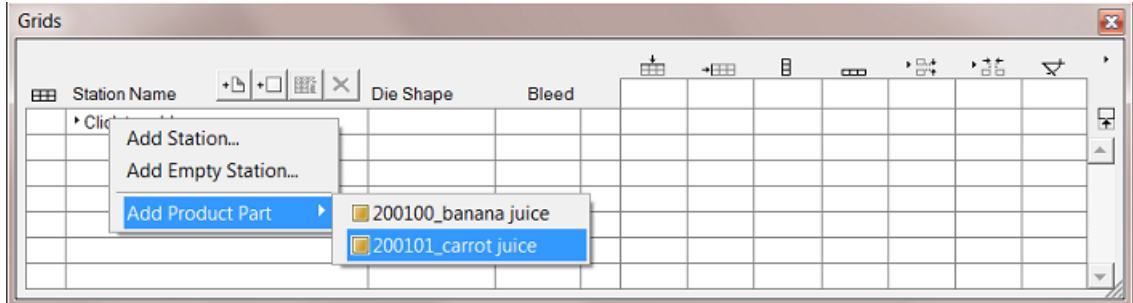

- When you create a **SmartLayout**, you can choose to **Load All Products...** that are linked into that job. Customers who often make layouts with many different files will quickly see the benefit of this function:

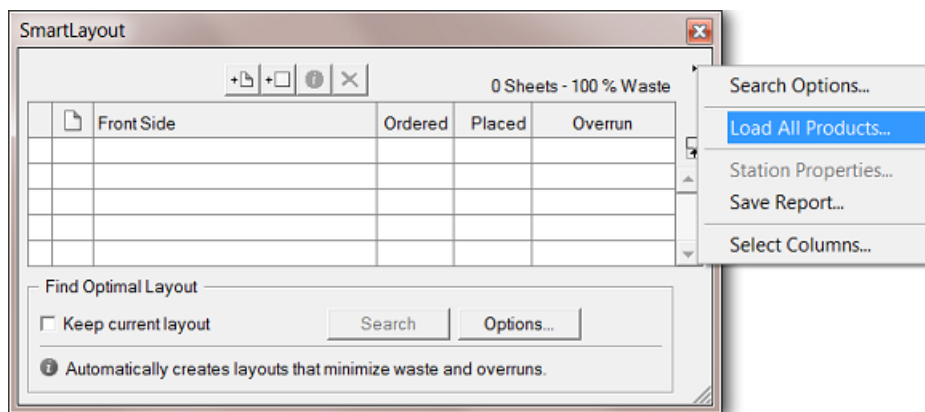

### In Esko Plato: Using the Product Parameter "Ordered Copies"

When you load a product part in **SmartLayout**, Plato also checks the *Product Setup* parameter **Ordered Copies** and automatically fills it in the **SmartLayout** dialog.

An example: This product is linked into 3 jobs but for job 440123 there are 7.500 **Ordered Copies**:

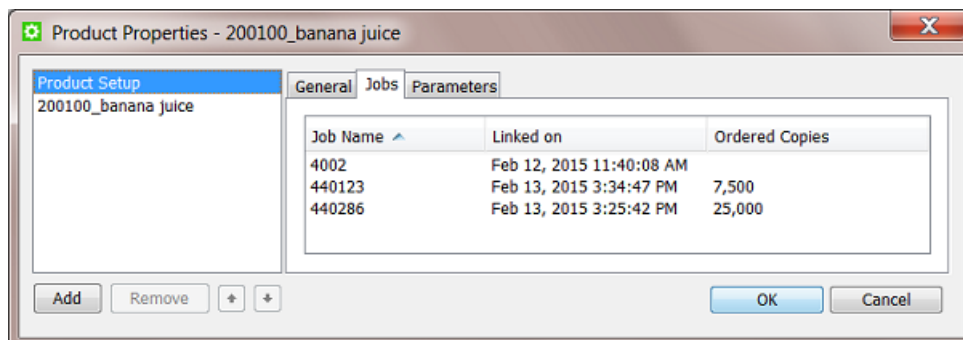

When Plato works in the context of job 440123, and when you use that product in your SmartLayout, that number of ordered copies will be filled in automatically:

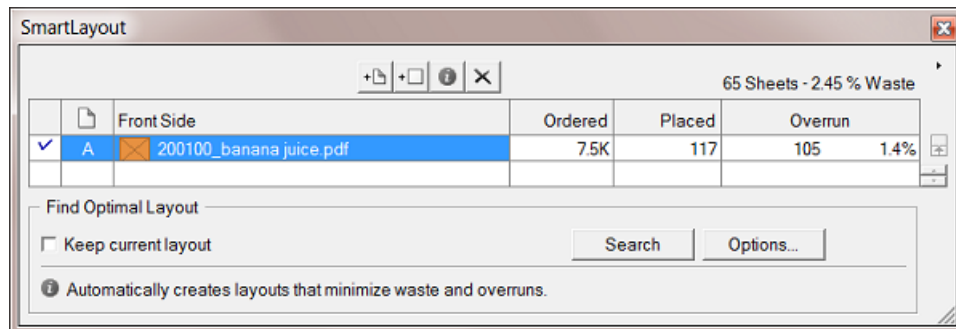

Learn more about Plato [here](#).

## 8.9. Tasks specific for Products



**Note:** We here list the tasks. There are also workflow controls that are specific to **Products**. Those are documented [here](#), in the chapter [Workflows](#) on page 733.

### 8.9.1. Task 'Add to Products'



**Attention:** This task requires you to be familiar with the manual setup of [Products](#) on page 594.

You can use this task to create a product (part) or to add or modify parameters of a product (part). You can not delete product (part) parameters using this task. Learn more below on how to update fields.

The setup fields can be filled with SmartNames, typed in values or values chosen from a list.

**Select item to set up:** There are different tab sheets for product and for product part setup. Every product has at least one product part, so both are important.

#### Setting Up the Product

- **General:** You here define the main product properties. This tab is similar to the **General** tab when you manually define a **Product Setup**. Learn more about each field in [Product Setup](#) on page 612.



- **Parameters:** You can here define custom product parameters. This tab is identical to the **Parameters** tab in the **Product Setup**. Learn more about each field in [Product Setup](#) on page 612.
- **Updating:** When a product with the same **Product ID** or **Product Name** already exists, this task will update that product. Define the rules here.

- **Update:** If you want the existing product to be updated with the info from the task.
- **Do not update:** If you do not want the existing parameters to be updated.
- **Update and provide a warning.**
- **Do not update and provide an error.**

**Link Global Product to the current Job:** If you enable this the product in the task will be linked to the current job context.

- **Create Customer automatically when it does not exist yet.** Indicate if you want this.



**Note:** Mind that a customer exists when the **Customer ID** already exists.

### Setting Up the Product Part

The settings for the product part as very similar to the ones for the product, that we explained here above.

For the part, there are extra settings for the part's **File**:

- **Update:** If you want to update the product part with your task input file.
- **Do not update:** When the product part should not be updated with your task input file.
- **Update and provide a warning.**

### 8.9.2. Task 'Link Product to Job'

The **Link Product to Job** task allows to link one or multiple products to a job.

It also allows to specify the **Ordered Copies**. This is the *amount* of product items that need to be produced in that job order.

#### Select Job

The job to link to can be indicated via its **Name** or via the combination of **OrderID** and **SubOrderID**. You can select a specific job from the list but typically you will enter a SmartName here.



**Note:** When the job does not exist, the task generates an error.

#### Ordered Copies

Enter the amount manually or use a SmartName. Learn more in [Product Setup](#) and in [using the ordered copies parameter in Esko Plato](#).



**Attention:** When the input file belongs to a product that was already linked to that job, you can still use this task to (only) update the amount of ordered copies.

#### About the Task Input File

- When the input file is a product part of an existing **Global Product**, the product is linked to the specified job and the ordered copies is set for that job (if the product was not yet linked to the specified job).
- When the input file is a product part of an existing **Job Product**, the task generates an error.
- When the input file is not yet a product part, the task generates an error.

### 8.9.3. Task 'Remove Product'

#### Concept

This task removes a product from the products database. It is typically used in a workflow where it is preceded by the [Select Product](#) workflow control.



As described in [the Products Concept](#), products should be removed from the database when they are no longer relevant to your production. This decision is often taken by the business system. You can set up an automated workflow where that business system triggers a workflow that removes the product(s) that the business system described in an XML file. Learn more about triggering tasks from a business system in [Integrating with External Systems](#) on page 1769.



**Attention:** This task does not remove only parts from a product. This means that also when the input of this task is a product part, it will be the product that this part belongs to that will be removed. This means that this task cannot be used to only remove part(s) of a product.

#### General Behavior

- When the input file is a product with multiple parts, then that product and all its parts are removed from the database (and optionally from the file system, learn more below).
- When the input file is a product part, the product that that part belongs to is removed.
- When the input file is a product part which is shared by multiple products, then all those products and their parts are removed. There will be no warning if that is the case.
- When multiple inputs are specified, the task removes all corresponding products and all of their parts.
- When an input product name or ID matches both with (one or more) **Job Products** and also with (one or more) **Global Products**, then
  - when this task runs in the context of a job, then only the matching job product of that job will be removed.
  - when this task does not run in a that job context, all the matching global product(s) will be removed.
- When the input file is not a product (part), then, in a workflow context, the output of the task is the input file and is put on the **Error** pin.

#### Task Settings

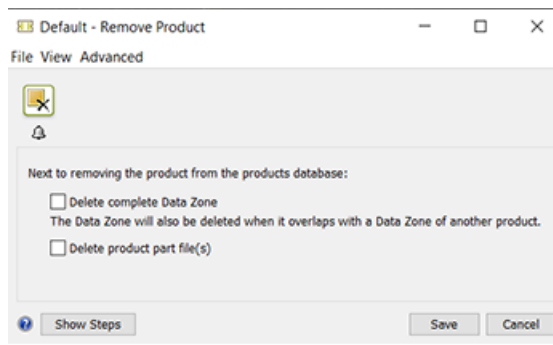

- **Remove file.** This will also remove the file of that product part.
- **Remove complete data zone.** This will also remove the complete data zone of the selected product. Learn more about data zones in [Products Data Structure](#) on page 599.



**Warning:** A data zone can overlap with the data zone of other products! There will not be a warning or error in such a case!



**Attention:** We advise to only choose to remove the complete data zone when you are sure you have a backup of those data.

Learn more about removing products in [Removing Products](#) on page 635.

### 8.9.4. Task 'Manage Product Status'

The **Manage Product Status** task allows to set the status of a product.

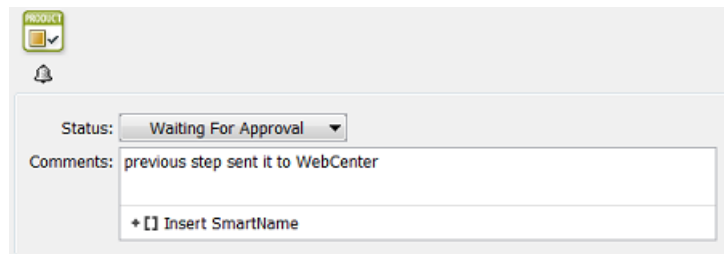

You can add an extra comment.



**Tip:** Adding a comment is most useful when the status change was a user's decision. For example a comment that mentions that the customer couldn't approve via E-mail or web due to network problems and so exceptionally called you to confirm that he approves the file.

This task is often used to automatically set the product status during a workflow. See some examples in [Creating Products Automatically](#) on page 617.

### 8.9.5. Task 'Wait for Product Status'

The **Wait for Product Status** task allows to hold a workflow until (all) the input product part(s) reach the status specified in the ticket.

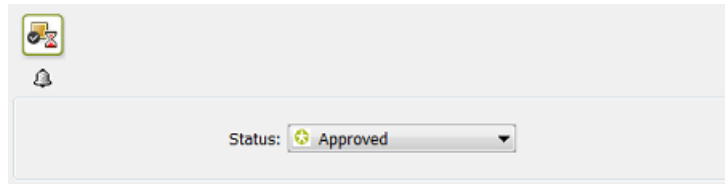

This task will wait until **all** Product Parts reach that status.

Learn more about product (part) status in [The Product Menu](#) on page 610 and in [Product \(Part\) Properties](#) on page 611.



**Note:** This task ends in error

- when none of the input files are product parts.
- when one of the input product parts is deleted from the products database while the task is waiting.

This task is typically used to prevent output before the product part(s) are approved. See this example workflow:



Notice how the input of the **Wait for Product Status** task is defined by the [Select File](#) step that has a specific option to select all the product parts in the job:

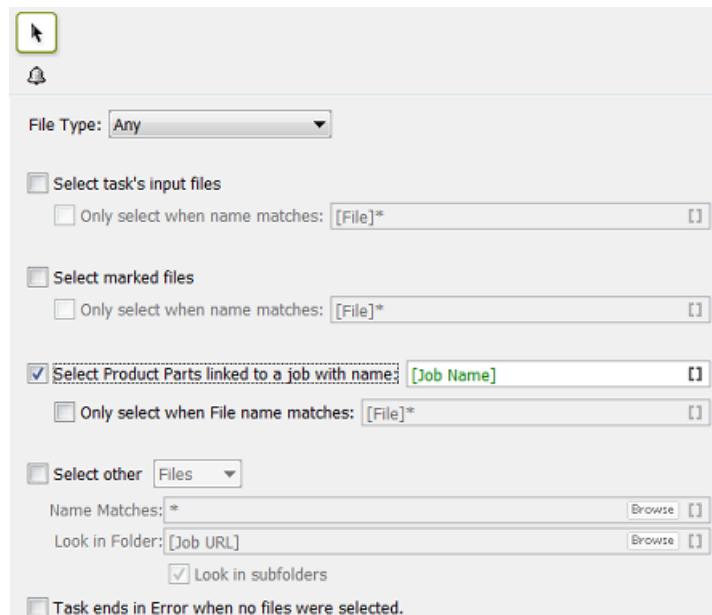

### 8.9.6. Task 'Check Job and Product Parameters'

This task is documented in the chapter on [Jobs](#).

Find a direct link [here](#).

### 8.9.7. Task 'Check Product Parameters (Classic)'



**Note:** The concept and tools explained here are very similar to those in the [Task 'Check Job Parameters \(Classic\)'](#) on page 590.

The **Check Product Parameters** task allows to make sure that the barcode and/or inks of the task's input file match the properties specified in its [Product Part Setup](#). You can use the task just to check the file or you can use it to automatically correct the file.

Category	Action
<input checked="" type="checkbox"/> Barcode	Auto Correct
<input checked="" type="checkbox"/> Inks	Auto Correct
	Auto Correct (Strict Checking)
	Stop with Error



**Note:** The input file must be a **Product Part** file.



**Important:** When no output file name or folder were specified in the ticket, the **Auto Correct** actions will overwrite the input file.

For **Barcode** settings, you can select:

- **Auto Correct** when you want to correct the file according to what is specified in its [Product Part Setup](#).

For example, your normalized PDF includes an Esko barcode of type EAN-13 and code 123456789012, and your product part specifies EAN-13 and code 5449000050205, then this task will automatically correct the barcode number in the PDF to 5449000050205.

- **Stop with Error** when you want the task to stop with an error if the barcode in the [Product Part Setup](#) does not fully match the barcode in the file.



**Note:** This task only checks barcodes created in Esko PackEdge or by using Esko's barcode plug-in for Adobe Illustrator (DeskPack). If the task does not find such a barcode, the task will end in a warning.



**Note:** You cannot use this task to check and auto correct barcodes in normalized PDFs generated by **ArtPro**.

For **Inks**, you can select:

- **Auto Correct:** For each ink in the input file, the task checks if the characteristics of the ink match the settings in product part parameters. If they don't match the file is corrected.
- **Auto Correct (Strict Checking):** Same as above but also generates an error if the file's list of inks and the order of inks is not exactly as defined in the product part parameters.
- **Stop with Error:** This is a strict check on the list of inks, their order and their characteristics.

### 8.9.8. Task 'Change Location of Products'

The term '**Location**' here refers to the concept of data-filtering as explained in [Filtering on Locations after consolidating all data](#) on page 1676.

In a setup where you decided to use this Location attribute for Products, you might start with many Products that do not have this attribute set yet.

This task enables to set (or update) this location attribute for all Products that match the filter defined in the task ticket.

You can not start this task by first selecting a set of Products ; this selection is built into the task itself.

1. Make a task ticket with the wanted filtering of Products.
2. In the Workflow Editor, add this ticket to a workflow and save this workflow.
3. Launch this workflow (from within the editor or later for example as a favorite ticket).

## 8.10. Publishing Products to WebCenter

---

You can use the task [Publish On WebCenter](#) to publish files from within an Automation Engine Container to a WebCenter project.

When you launch that task on an Automation Engine product,

- the product part file will be stored as a project document
- the product part file will also be stored as a document in the **Bill Of Material** of that WebCenter project. The product (part) properties can be stored as WebCenter document attributes.



**Note:** The reverse is not possible: it is not possible to push WebCenter document attributes to Automation Engine product parameters.

Learn more about this in [Publishing Products to WebCenter](#), a page in the dedicated chapter on [Integrating with WebCenter](#) on page 1741.

## 8.11. Backing Up and Archiving Products



**Important:** Users of an Automation Engine SaaS setup can also use Esko Cloud to store inactive Products data. This is not described here but in the [dedicated chapter on AE SaaS](#).

### Backing Up Product Data

As explained in [The Products Concept](#) on page 594, data belonging to products are important data that you want to keep online for a long time. This is why we advise to schedule a regular backup of your product data. This can be done with many specialized (non-Esko) backup applications.

Additionally, we advise to use the [Backup](#) tool to also back up your databases. The products database contains the properties of all your products. Remember that you can not restore selections of this database, restoring is done on the complete database. And remember that the products database is not a separate database but a database table in the jobs database.



**Note:** Some customers also use the Pilot to back up the product part files. You can select all or groups of products in your products gallery and launch tasks that can copy that data to a near-line disk or off-line to some device (CD/DVD). You can launch the [Create PAF / JPG / XML \(LinkEdge\)\(Classic\)](#) on page 277 task (on normalized PDFs) or the [Copy](#) task or you can create workflows that copy the whole product part data zone. If you accidentally lost product data, it will then be easy to recuperate a selection of that copied data.

### Archiving Product Data

As explained in [The Products Concept](#) on page 594, a product should stay in your database as long as a job-order can come in that needs (to output) it. Ideally, the business system informs you when its users have decided that a product item is 'end-of-life'.

Some customers keep some outdated products in the database to use them as basis for new designs. When you do this, mind that exceptionally large databases may cause your system to slow down.



**Tip:** When you do keep outdated products in the database, make sure to give them a status that is easy to recognize, for example `end-of-life` or `do not output`.

Another reason to remove old products is to avoid the risk of using them again in production.



**Tip:** You can reduce that risk by using a workflow that checks the status before outputting. See an example in [Task 'Wait for Product Status'](#) on page 630.



**Important:** The task [Archive Job](#) archives and restores job folders and job products. Global product files are not stored inside job folders and will not be archived by this task.

In summary, there is no specific task or procedure to archive products. We advise to stick to these general rules:

- Make regular backups of all your product data and database.
- Remove products from the database when you can.
- Use the product status to help indicate if a product can still be used for output.



## 8.12. Removing Products

---

### What Happens when you Remove a Product?

When you remove a product, the product and all its parts are removed from the product database. The product part files on disk are not removed.

Removing a **Global Product** does not leave a memory of the product (part) parameters. When you make the file a product (part) again, it will not propose you any previous settings.

This is different when the product was a **Job Product** that was removed together with the job. When you remove a job it always stores a memory of all its settings in a subfolder and this is also done for settings of any job products. When you then use that ex-jobfolder to (re-)create a job, the old product(s) are re-created in this job as job products and will have all their product (part) settings again.

### When do you Remove a Product?

As mentioned in [The Products Concept](#) and in [Backing Up and Archiving Products](#), (global) products are created to be used for a long term.

It makes sense to remove a product when you are sure it will never need to be produced (output) again. In other words, when there are no more benefits of having it in a database: when you don't link it into jobs anymore or you don't use its SmartNames any more.

### Removing a Product when in Container mode

In the Product Gallery, select the product(s) and press `Delete` or use the right-click or menu function **Product > Remove Product**. A dialog will ask you to confirm.

By default, you can not remove products when they are still linked to a job. However, you can force this removal by using the option to also remove those job-links at the moment you remove the product(s). This is the option **Also remove from linked jobs** or **Also remove linked products from all linked jobs**.

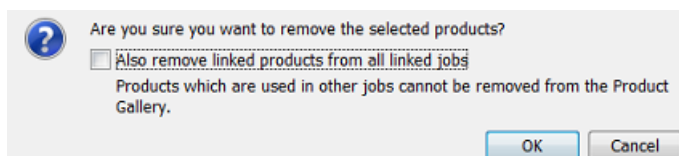

### Removing a Product when in Job mode

When you are in a job's **Products** view and you select a linked product, pressing `Delete` serves to **Unlink** the product from that job. However, the resulting dialog offers an option to **Also remove** the product from the products database:

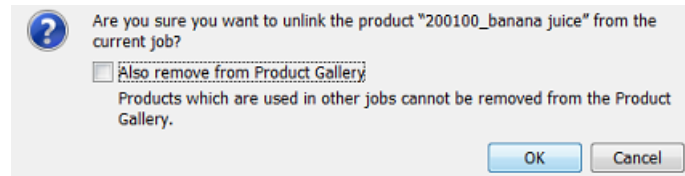

When you are asking to remove a product that is still linked to other jobs, you will see this warning:

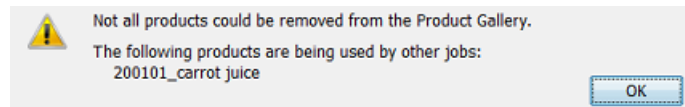

If you want to remove products that are linked to multiple jobs, you need to do this in Container mode (in the Product Gallery).

# 9. SmartNames

## 9.1. Concept

### What is a SmartName?

A SmartName is a variable that refers to a value. You use them by inserting them in input fields all across Automation Engine. For example the SmartName [File] refers to the name of the task's input file, and the SmartName [Date] refers to the date the task is launched.

SmartNames are shown in green and between square brackets. For example [File] .

### Where can SmartNames be used?



**Note:** Not all SmartNames can be used everywhere. Learn about limiting the places where they can be used in [SmartName Scopes](#) on page 648.

- **In Task Tickets, Workflow Steps and Access Points**

See an example of a **ReportMaker** ticket:

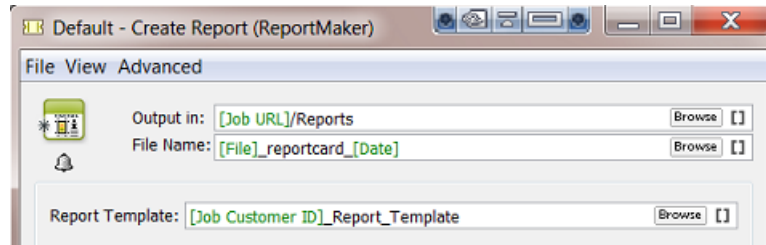

The output file will be written in the Job Folder, in a subfolder 'Reports'. The output file name will start with the name of the input file name plus the suffix '\_reportcard\_' and ending with the date when this task is launched.



**Tip:** You here also see how you can make combinations of SmartNames and regular (static) text.

The report template that will be used starts with the customer's ID number and ends with '\_Report\_Template'. This makes the ticket smart enough to select the template that this customer prefers.

- **In some fields of the Job Setup**

In this example a SmartName defines the code of the barcode in the Job Setup (the code is a variable that will be coming in from an XML file):

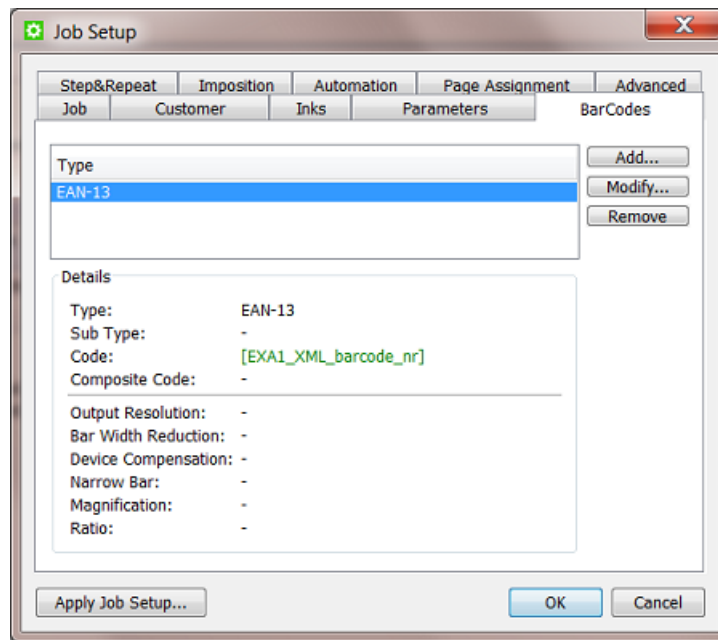

- **As Workflow Parameters in Workflow Steps**

When your workflow contains **Workflow Parameters**, you can pick them up as **Workflow Parameters SmartNames** in task tickets of tasks used in that workflow. Learn more about Workflow Parameters in [Workflow Parameters](#).

- **Inside SmartMarks**

See this example of how a **SmartMark** (here in **PackEdge**) uses a **Smart Text** that also picks up 2 SmartNames:

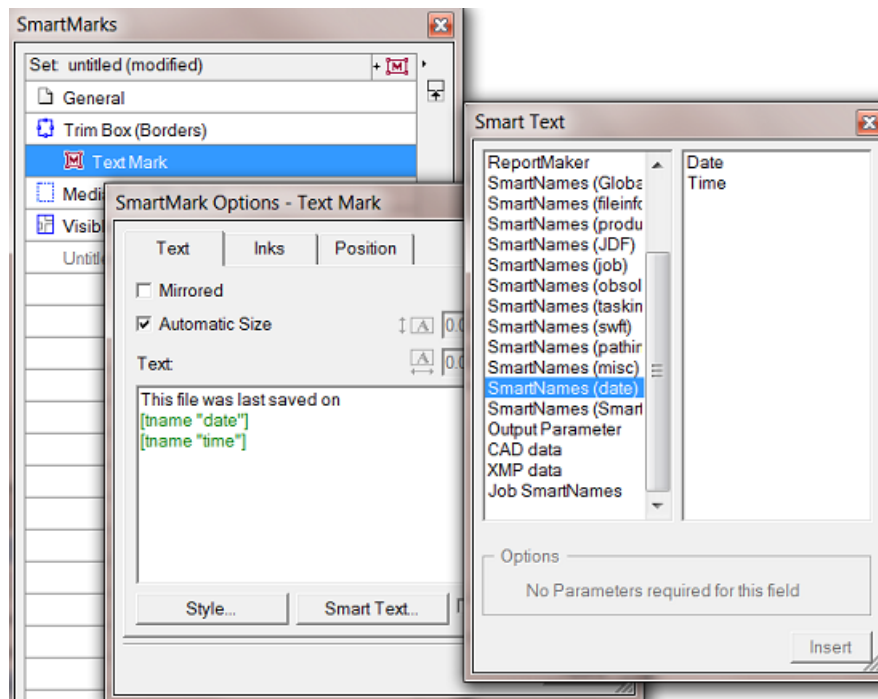

- **Inside the setup of other SmartNames**

Some examples:

- You can create a custom SmartName that extracts the first 5 characters from the [Job Name]
- In below example, a conditional SmartName 'EXA\_Which\_Site\_Is\_Closest' compares the value of two other SmartNames

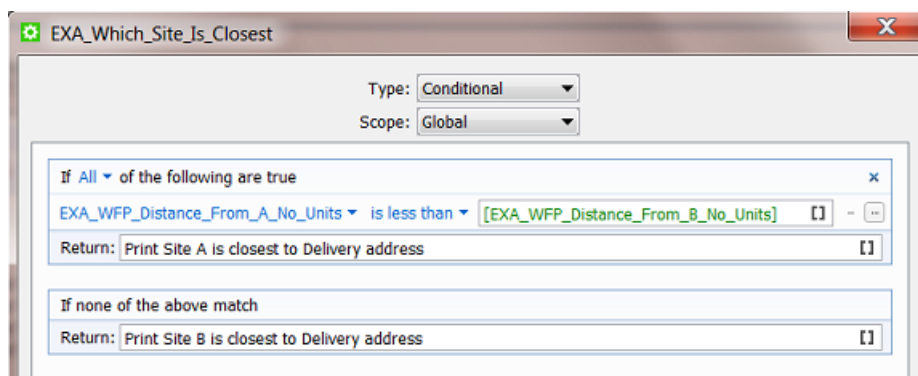

- **Inside some fields in the Customer setup**
- **In Configure, in some setup fields of Jobs and Products**

### Advantages

SmartNames are a crucial part of Automation Engine's power. They bring speed and error reduction to your workflow through these effects:

- **Consistency.** Folders and file names will be consistent, no typing errors.
- **Automation.** You will rarely need operator intervention to edit workflows.
- **Integration.** SmartNames can pick up their value from other systems without human intervention.
- **Organisation.** Making workflows smart means you need to prepare less workflows. Smart workflows adapt to the input files and the variable job instructions.

When you first install or update Automation Engine, you already get many **Default SmartNames**. You can also make your own.

In the next chapters, we first give an overview of the general principles. Then we describe the different types of SmartNames in more detail. We both explain the default ones and then show you how to create your own.

## 9.2. General Principles

---

### 9.2.1. Using a SmartName

There are 2 ways to use an existing SmartName:

- click on **[ ]** to open the **SmartName Browser**. Choose a category, select the SmartName and click **Insert**.

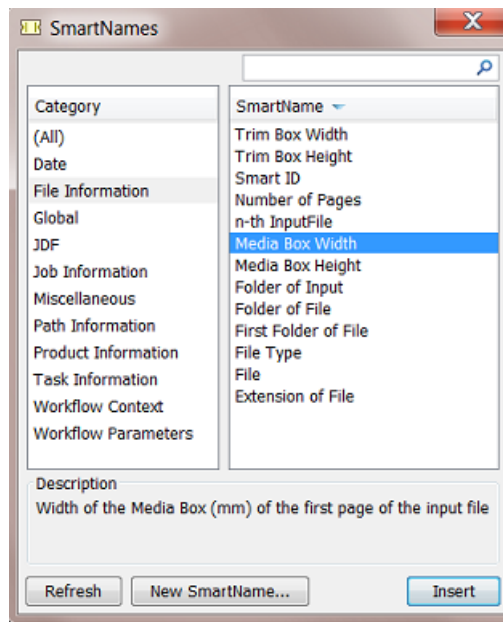

- When you want to insert multiple SmartNames, press ALT while clicking **Insert**. Then, the **SmartName Browser** will not close.
- You can filter the shown SmartNames by entering text in the search filter top-right. Use double quotes (") when an exact match is required.
- You can even combine search filters. For example when you type '123 exa', you ask to see SmartNames that contain both 123 **and** exa in their name or **Tag** (learn about tags [here](#)). Add a semicolon '123 ; exa' to see SmartNames that contain 123 **or** exa.

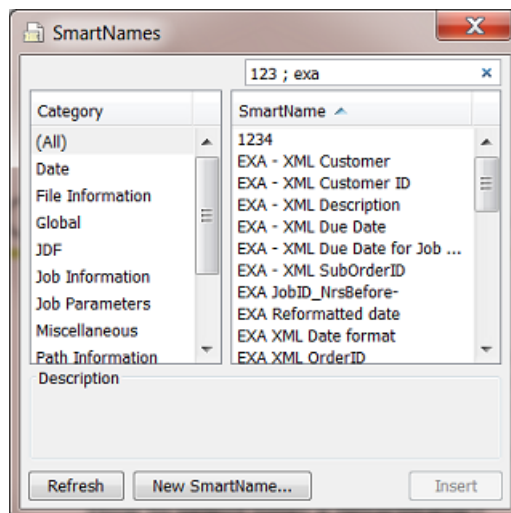

- Click **Refresh** to make sure that the most recent created SmartNames are also shown (or press CTRL-R or CMD-R).
- Click **New SmartName** if you want to create a new one from here, while keeping this dialog open.

- right-click in the field, choose **Insert SmartName...** and choose a SmartName from the offered categories.

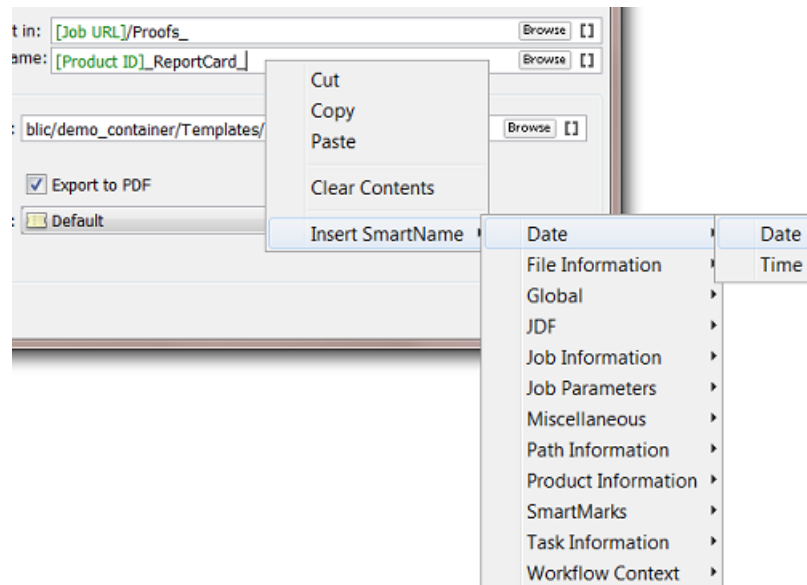

**Important:** In both ways, make sure you first position your cursor in the exact place where you want to insert the SmartName.



**Tip:** It is possible to select and cut, copy and paste SmartNames.

## 9.2.2. The SmartNames View

The **SmartNames View** in your **Pilot** is where you

- see all your SmartNames, both the default ones that came with Automation Engine and the ones your users created
- add filters to help find and organize them
- create, modify or delete SmartNames (if you have the **User Access Right**. Learn more in [Access Rights](#) on page 157).
- test your SmartNames ("resolve").

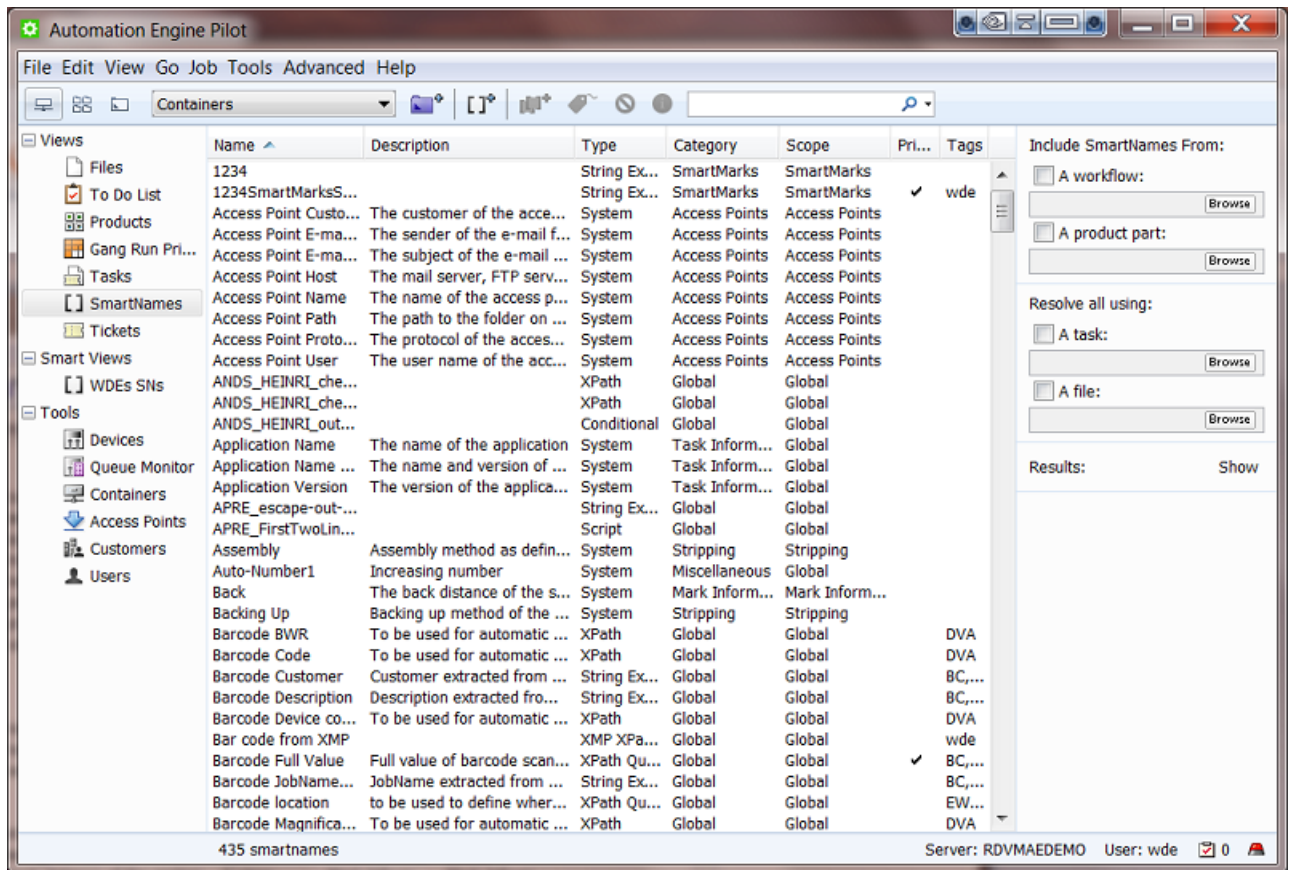

As usual, you can control the columns in this view. To do this, go to the menu **View > Select Columns in 'SmartNames'...** (by default they are all shown).

You can add a **Description** to your custom SmartNames. This quickly reminds you what they are for, without the need to open and analyse them.



**Tip:** The **SmartNames View** is not available when your Pilot is in **Jobs Overview** mode.



**Tip:** When you choose **Tools > SmartNames**, the **SmartName View** opens as a separate window.

### Columns Overview

We here briefly describe what these columns mean. Find more detailed descriptions on some of them in the next pages.

- **Type.** The type is an important distinction. It defines what kind of technique the SmartName will use to get (resolve) its value. Will it get the value from a database inside Automation Engine? Or by asking the database of an external system? Or from an XML file or from another SmartName? All types are documented in [SmartName Types \(Overview\)](#) on page 644 and later in even more detail.
- **Category.** Categories are an old way of helping you filter and group SmartNames. We recommend using **Tags** instead (see further).



- **Scope.** By default the **Scope** of a SmartName is **global**. This means you can use it everywhere. Defining a different (smaller) **Scope** for a SmartName means that you want to limit the zone where it can be used. For example: if you define the **Scope** 'Step & Repeat' then you indicate that this SmartName makes no sense to be used outside that concept of Step & Repeat. More on this in [SmartName Scopes](#) on page 648.
- **Private.** You can save a SmartName as **Private**. Private SmartNames are not visible when applying SmartNames in a ticket. They do not appear in the list or the **SmartName Browser**. Two examples why you would hide them in this way:
  - the SmartName is only used as a sub-component of one or more other SmartNames (that users *will* see and use)
  - you are still testing a new SmartName in the **SmartName View** and you do not want other users to already use it.
- **Tags.** Adding custom tags to a SmartName helps you filter and group them. Learn more in [SmartName Tags](#) on page 649.
- **Modification Date** and **Modified By:** These fields are updated when changes are done to the **content** of the SmartName (so not when adding tags or description or making private or duplicating it). An imported SmartName initially keeps the modification date from its origin SmartName.

### The right panel

On the right side of the **SmartNames View**, you can add more SmartNames to the list and you can test them extensively. Learn more in [Testing SmartNames](#) on page 652.

### Search on Content

The search criteria in this view also offer to base a search on the **Content** of a SmartName.

This can for example be useful when searching for SmartNames that contain the actual computer name of a server.

When searching on content, the following data is taken into account (per type of SmartName):

- Database Query: The SQL Command
- String Extract SmartName: What is mentioned in "Extract Part of"
- Script SmartName: The script
- XMP XPath Query SmartName: The XPath Expression
- XPath Query SmartName: The XPath Expression
- Conditional SmartName: All text criteria / All return values
- 32-bit ODBC Query SmartName: The SQL Command

### Advanced Search Criteria for SmartNames

As in many other **Views** in the **Pilot**, you can use **Advanced Search Criteria**. To activate this, type in the **Find** field or press CMD-F (Mac) or CTRL-F (Windows). You see the criteria of the current filter. Click the + or - to add or remove extra lines of criteria.

This screenshot is an example of a filter that shows all SmartNames with `exam` in their **Tag**.

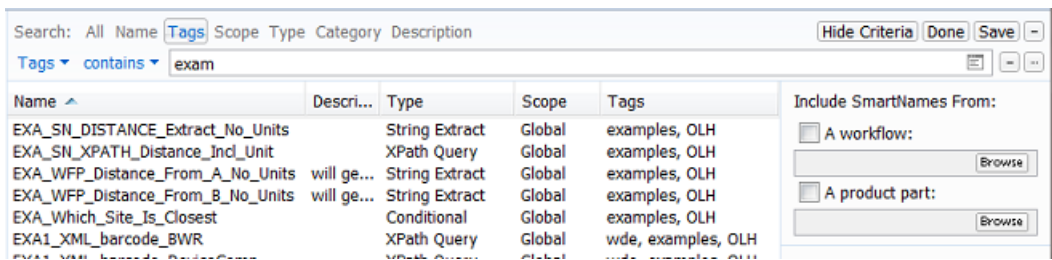

Click **Save** to save this filter. Define if this filter is for yourself or for all users. Decide if you want to **Add to my views bar**.

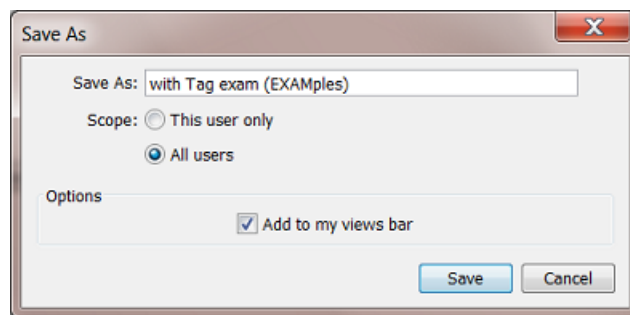

See an example of custom **Smart Views**:

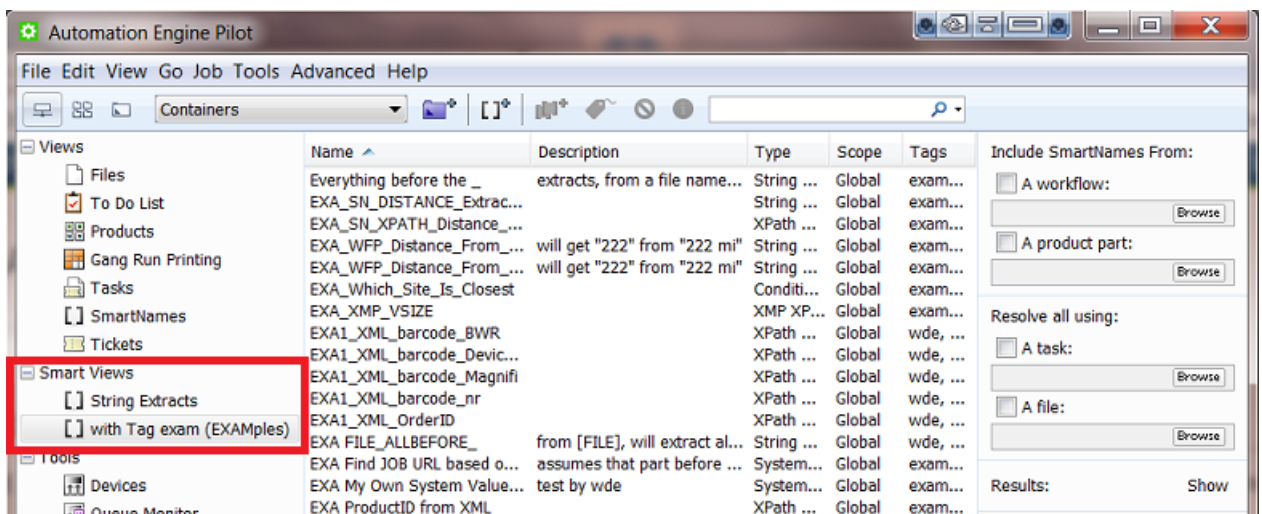

### 9.2.3. SmartName Types (Overview)

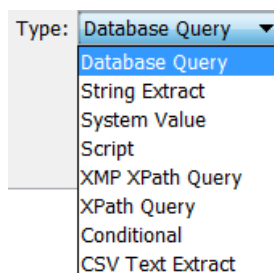

Later in this document we describe each type in detail. Here is an introduction:

### Database Query SmartNames

These retrieve a value from an external database. This is useful when there is no other way that the external system can send the information to Automation Engine (via XML or CSV or E-mail ....)

Learn more on in [Database Query SmartNames](#) on page 692.

### String Extract SmartNames

These SmartNames extract a part of a string of characters (text or numbers). For example: when the input is '123-abc', then extracting all characters before the '-' will result in '123'.



**Note:** The string from which the value of the SmartName is extracted can contain other SmartNames. For example: extracting the first 5 characters of the [JOB ID].

Learn more on in [String Extract SmartNames](#) on page 671.

### System Value SmartNames

These retrieve a value from one of Automation Engine's own databases. You get these when you install or update your Automation Engine server software. For example [Access Point E-mail Sender] (only valid in the context of an **Access Point**)

Learn more on in [System \(Value\) SmartNames](#) on page 661.

### Script SmartNames

These use **JavaScript** to define a value.

Learn more on in [Script SmartNames](#) on page 694.

### XMP XPath Query SmartNames

These retrieve a value from the XMP (metadata) section of a PDF. For example when it was last modified or the PDF version number.



**Note:** This obviously only works for PDFs that have XMP metadata. This excludes PDF+ files. Learn about this different type of metadata in PDF+ files in [Metadata in PDF+ \(vs. XMP in Normalized PDF\)](#) on page 55.

Learn more on in [XMP XPath Query SmartNames](#) on page 682.

### XPath Query SmartNames

These use XPath Queries to retrieve a value from an XML. The **XPath Builder** is a great help to construct these **Xpath expressions**.

Learn more on in [XPath Query SmartNames](#) on page 676 .

### Conditional SmartNames

These return a value based on a condition. For example a SmartName 'Trapping size' has these conditions: if the workflow parameter 'Printprocess' is 'flexo', then return '0,2' and if the workflow parameter is 'digital' then return '0'.

These SmartNames are also often used to route workflows in one or the other direction.

Learn more on in [Conditional SmartNames](#) on page 686.

### CSV Text Extract SmartNames

These extract a value from a CSV file. For example take the value from field 5 on line 2.

Learn more on in [CSV Text Extract SmartNames](#) on page 674.

## 9.2.4. SmartName Categories

SmartNames are sorted into categories, so you can find them more easily. The **SmartName View** and the **SmartName Browser** show you these categories and their members:

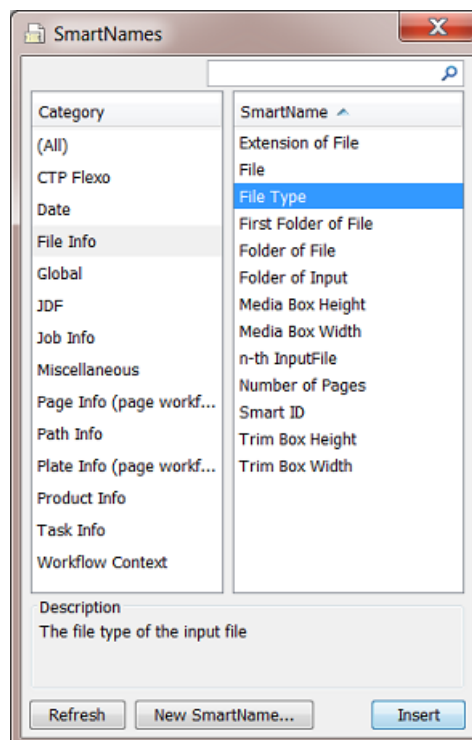

### Flexo

These SmartNames are useful when working with the View modes of the category [Flexo](#).

### Date

Use SmartNames of this category to insert the [Date] or [Time] of their execution.

### File Information

These SmartNames return file-related information from within the file itself (for example [Media Box Width] ) or from within the Automation Engine database ([File Type], [Folder of File], [SmartID] ...). The most popular one is [File], representing the name of the ticket's input file.

### Global

This is a full list of all the SmartNames that can be used anywhere throughout Automation Engine. The ones with a limited **Scope** will not be listed here.

### JDF

These SmartNames are only used in tasks where JDF constructs are used. Learn more about JDF in [What about JDF?](#) on page 1771.

### Job Information

These SmartNames refer to most of the fields in a **Job** setup, including the details of **Customer** and **CSR** for that **Job**. Information on the location of the **Job** is part of the category **Path Information**. Any custom **Job Parameters** are also a separate category.

### Job Parameters

When you are in a Job context of a Job that has custom **Job Parameters**, you will see them here. Their name automatically starts with 'jp. '

### Miscellaneous

- Some SmartNames return the name of the Automation Engine server(s). They are useful when you use **Assistant** servers.
- [Auto-Number1] will add a sort-number to a group of output files. This helps sorting files. Learn more [here](#).

### Page Information

These SmartNames offer information on the (PDF) page attributes, typically height and width. You typically use these in the (page) imposition related tasks like the **Export Imposition to PDF File**.

### Path Information

These SmartNames correspond to the Job's location. Learn more in [System \(Value\) SmartNames](#) on page 661.



**Tip:** If these SmartNames are greyed out (unavailable), it means that the field you want to insert them into is not a path field.

### Plate Information

These SmartNames offer information on the plate attribute of a (page) imposition. You typically use these in the task **Export Imposition to PDF File**.

### Product Information

These SmartNames are only useful when you use the [Products](#) tool in Automation Engine. Much like the category **Job Information**, this category relates to the many fields in the **Products** database of Automation Engine.

Learn more about setting them up in [Product \(Part\) Properties](#) on page 611.

### Task Information

This category of SmartNames allows to insert task related information (Task Name, Operator, Application Version...). Learn more in [System \(Value\) SmartNames](#) on page 661.

### Workflow Context

These SmartNames pick up specific names or paths of folder or files in a workflow context. They help avoiding that you have to make complex workflows or create complex custom SmartNames to achieve the same result.

Learn more in [System \(Value\) SmartNames](#) on page 661.

## 9.2.5. SmartName Scopes

Depending on where you are in Automation Engine, different SmartNames may be available for use.

### Global SmartNames

These SmartNames are available everywhere where SmartNames are offered.

### SmartMarks SmartNames

These SmartNames are only available when using SmartMarks. In the page [Concept](#) on page 637, find an example where a SmartName was used to decide the Smart Text in a SmartMark.

### Step & Repeat SmartNames

These SmartNames are **only** available in **Step & Repeat - Classic** tasks.

### Mark Information

These default SmartNames are only available in the task **Add Marks to Imposition** (page workflows only).

### Stripping SmartNames

These default SmartNames are only available when retrieving values from JDF files (with the **Import JDF Stripping** task).

### Imposition SmartNames

These default SmartNames are only available when working with impositions (for example, in the **Export Imposition to PDF File** ticket).

### Unit Text Field SmartNames

SmartName enabled unit text fields are available in tasks where units have to be entered. You can do unit conversions and simple arithmetic using the operators +, -, \* and /. You can also use parenthesis ( ) if necessary while calculating. **PowerTrapper**, **Change Imposition Layout** and **Create CAD sheet** and a few examples of tasks that offer such unit text fields.

Some examples:

[Width] inch

9 inch + 3mm

## 9.2.6. SmartName Tags

### Creating a Tag

The **Scope** of a SmartName defines *where* it can be used. The **Category** of a SmartName helps *filtering*. Adding **Tags** to a SmartName is an extra tool that enables you to *organize them via custom filters*.



**Note:** Tags are also shown in a separate column in the **SmartNames View**.

You can add one or more Tags when you save a new SmartName. When the Tag already exists, it will appear in light blue:

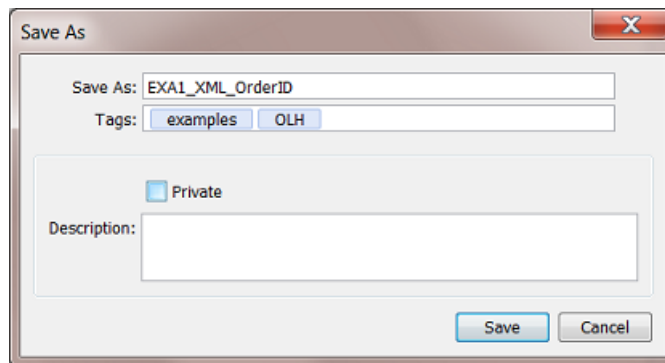

**Tip:** In the Tags field, press the space bar to get a drop-down list of all the Tags that were already created on your Automation Engine.

To add a Tag to an existing SmartName, select it, right-click and choose **Info** to edit and add one or more Tags.

To remove a Tag from a SmartName, select it and press the **Delete** button.

### Tagging multiple SmartNames

1. In the **SmartNames View**, (filter and) select the SmartNames you want to tag.

2. Right-click and choose **Tags...**. A dialog will show what Tags they already have in common: Tags that are not assigned to *all* selected SmartNames are shown in grey.

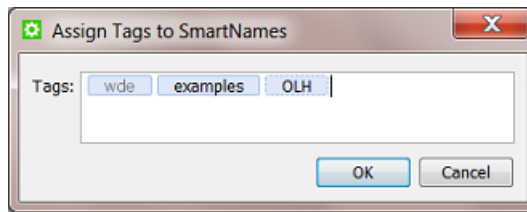

3. To add a Tag to all selected SmartNames, add the Tag and click **OK**.
4. To remove a Tag from all selected SmartNames, delete the Tag and click **OK**.

### Filtering SmartNames on Tags

To filter SmartNames on Tags,

- in the **SmartNames View**, select the search field and type the name of a Tag.



**Tip:** It is also possible to add a search row by pressing the **Add "+"** button in the **Scope** bar, and choosing **Tags** from the attributes list (that pops up on the left).

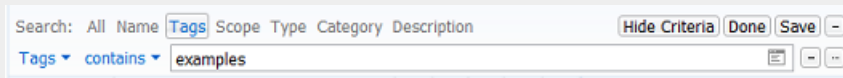

- when selecting a SmartName from the SmartNames browser, enter the Tag in the search field.

To filter on *multiple* Tags, separate the names by a space. For example to filter on SmartNames that have *both* examples and OLH as Tag, type "examples OLH" into the search field.

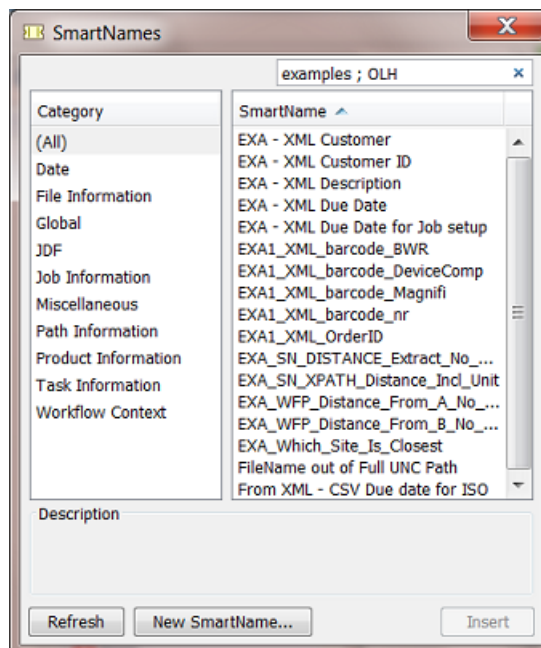



To filter on SmartNames that have *either* examples or OLH as a Tag, then separate the Tags by a semicolon ";" (see screen shot).

### Renaming a Tag

To rename a Tag, follow these steps:

1. Go to the **SmartNames View**, filter on the **Tag**.
2. Select all SmartNames that contain that Tag.
3. Right-click and choose **Tags...**
4. Double click the Tag to edit it and type the new name.
5. Click **OK**.

## 9.2.7. Creating a SmartName (General)

These are the general steps to create a new SmartName. Find more detailed instructions per SmartName type further in this document.

1. In your Pilot, select **Views > SmartNames**.
2. Click on the **Create a new SmartName** icon  in the toolbar. Alternately, choose **File > New SmartName**.

This opens the SmartName setup dialog:

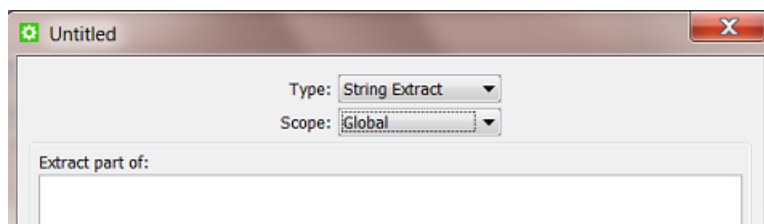

**Note:** Click  to select the attribute from a drop-down list.

3. Select the **Type**. We introduced the available types in [SmartName Types \(Overview\)](#) on page 644. See further in this document for a detailed setup instruction per type. Depending on which **Type** you choose, the dialog adapts to offer different options.
4. Select the **Scope**. We introduced the available scopes in [SmartName Scopes](#) on page 648.



**Note:** You can easily change the **Scope** later ; this does not affect the setup options.

5. Set all the required attributes. This is a general introduction ; see the specific settings per type further in this document.
6. Check the **Result** value (bottom left in the dialog).

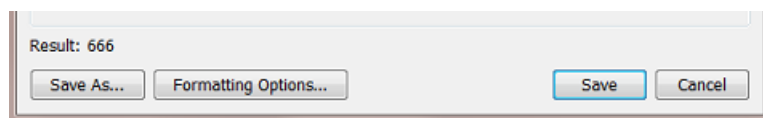

Depending on the example input data (file), you can already here see the example result with the already chosen settings.

- 7. Formatting Options...** . You can still change the formatting of that result (text, number, data and time). Learn more details in [Formatting SmartNames](#) on page 696.

For example your SmartName already extracts a date out of an XML, but you also want to change the format of that date from 25-Aug-14 to 25-08-14.

- 8. Click Save** and enter a logical **Name** and a suitable **Description**.

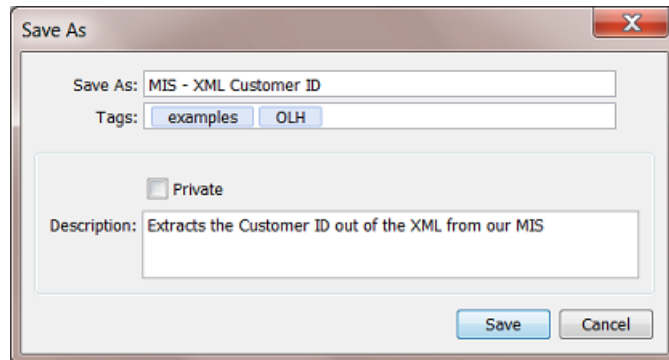

When you use **Save As...**, the dialog stays open. This is very useful when creating multiple variations of a SmartName one after the other.

[SmartName Tags](#) on page 649 explains all about adding **Tags**.

Decide if your SmartName should stay **Private**. Learn more about Private SmartNames in [The SmartNames View](#) on page 641.

- 9. Click OK.**

You can use **Save As...** in the **Add SmartNames** dialog to enter a new name for the SmartName. This is useful when creating multiple variations of a SmartName one after the other from the same dialog.

- 10. Check the result of your new SmartName** in more situations or tasks. Learn more in [SmartName Relations and Dependencies](#) on page 657.

## 9.2.8. Testing SmartNames

While creating new SmartNames you will want to test them. Instead of having to test them in a often complex workflow, you can use tools available in the **SmartNames View**.

This part of the View contains 2 main sections:

- **Include SmartNames From:** This part serves to show extra SmartNames that were not appearing in your list yet. Choose if you also want to show **Workflow Parameters** and/or **Product (Part) Parameters**. Learn more in [Also Show Workflow Parameter SmartNames](#) on page 653 and [Also Show Product \(Part\) Parameter SmartNames](#) on page 654. The reason that you also want to see them here is to test them as well. The next feature enables that:
- **Resolve all using:** This part allows you to test your SmartNames. You can test them on a task or on a file. Learn more in [Test your SmartNames with 'Resolve All Using'](#) on page 655.

### Also Show Workflow Parameter SmartNames

Follow these steps to show extra **Workflow Parameters** in your list of SmartNames:

1. In **Include SmartNames From**, check **A workflow** and browse to the workflow that has the **Workflow Parameters** you want to see here. They will immediately appear in your list of SmartNames (unless you have a filter setting that prevents that).
2. Tip: When your list shows many SmartNames already, it is possible you do not easily see them appear. Because they are here all shown starting with the prefix **wfp**, you can easily check their presence by typing a name filter 'wfp'. Alternatively, you could also use the **Category** filter **Workflow Parameters**.

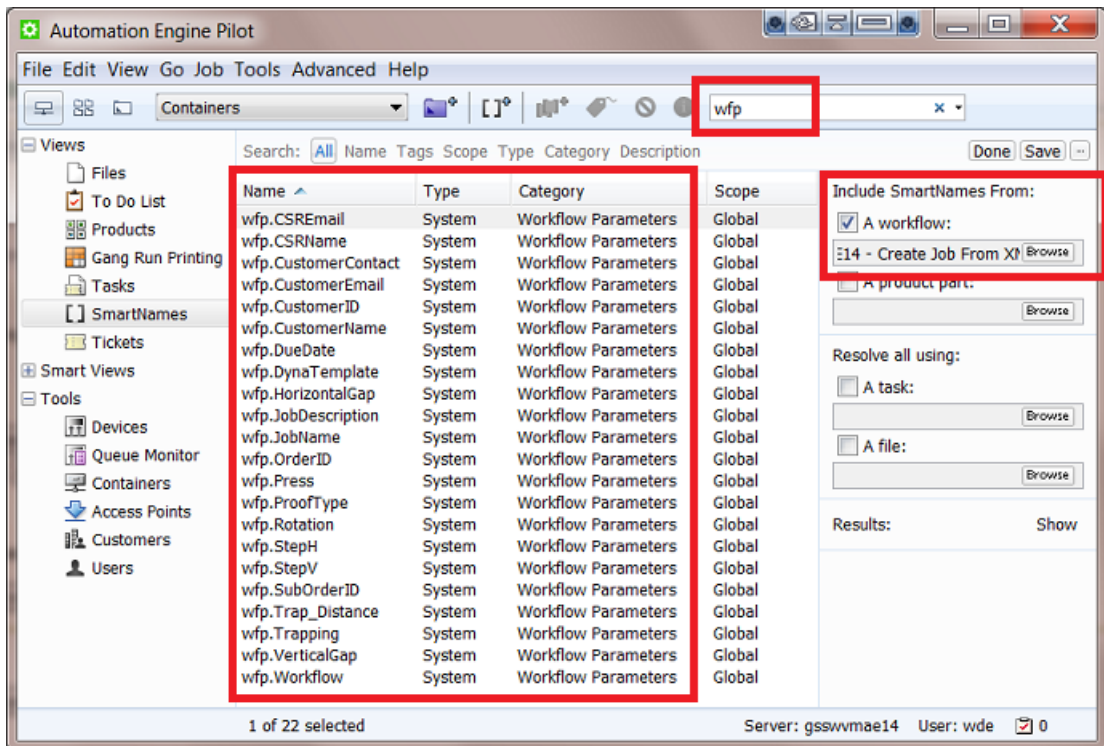

### Also Show Product (Part) Parameter SmartNames



**Note:** This feature is only useful when you are using Automation Engine's [Products](#) tool.

Follow these steps to show extra **Product (Part) Parameters** in your list of SmartNames:

1. In **Include SmartNames From**, check **A product part:** and browse to the product file that has the Product (Part) Parameters that you want to see here. They will immediately appear in your list of SmartNames (unless you have a filter setting that prevents that).
2. Tip: When your list shows many SmartNames already, it can be hard to find them back in the list. Because they are here all shown starting with the prefix **pp**, you can easily see them appear by typing a Name filter 'pp' or 'ppp'. Alternatively, you could also use the Category filter **Product (Part) Parameters**.

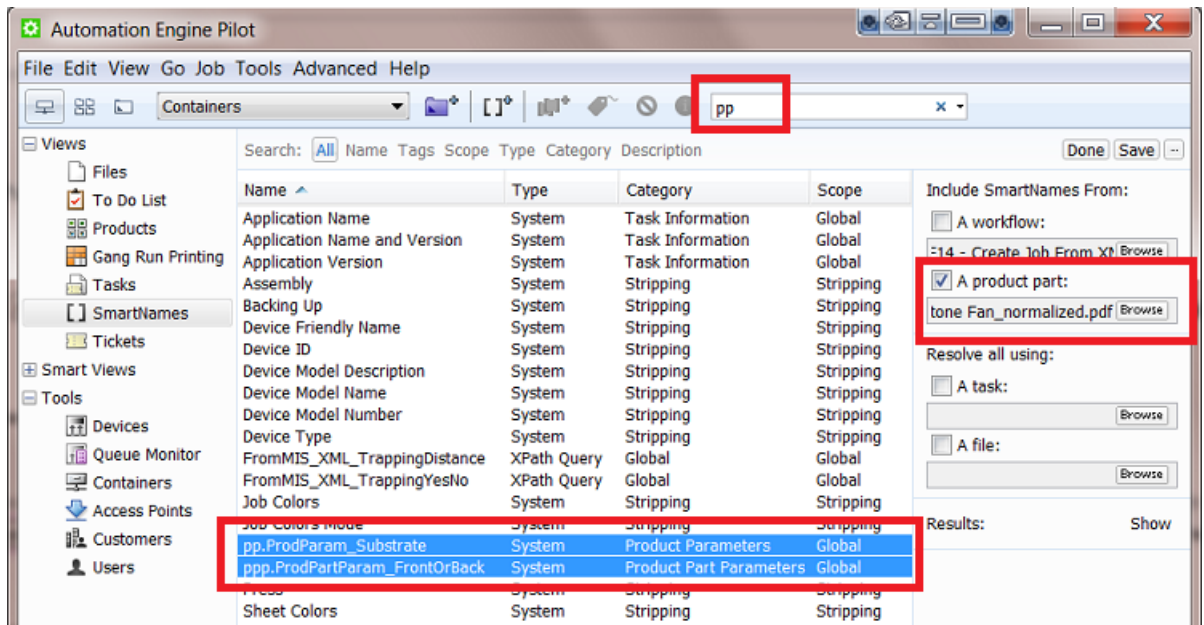

### Test your SmartNames with 'Resolve All Using'

The **Resolve All Using** tool in the **SmartNames View** enables testing your SmartNames. The basic principle is that you give an example input which is then tested on *all* SmartNames.

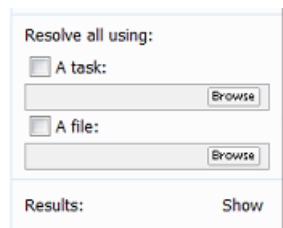

**Tip:** If the SmartName you want to test is a **Workflow** or **Product (Part) Parameter**, then first make it appear in the list by using the feature **Include SmartNames from**. Learn more on in [Also Show Workflow Parameter SmartNames](#) on page 653 and [Also Show Product \(Part\) Parameter SmartNames](#) on page 654.

#### "Resolve all using:" - An example:

1. Make sure the SmartName you want to test is visible in the list.
2. If you want to test the SmartName by using it in a task, then first make sure you have a finished task given a certain input. Then check **A task** and browse to the task in your task monitor dialog. If you want to test the SmartName by using it on a file, check **A file** and browse to that file.
3. Click **Show** to start resolving all your SmartNames with the selected file or task. This also adds an extra column to your **SmartNames View**. The example in this screenshot shows how the selected file `666-2712_ReportCard.pdf` made the SmartName `[Everything before the _ ]` resolved (resulted) in the `666-2712`.

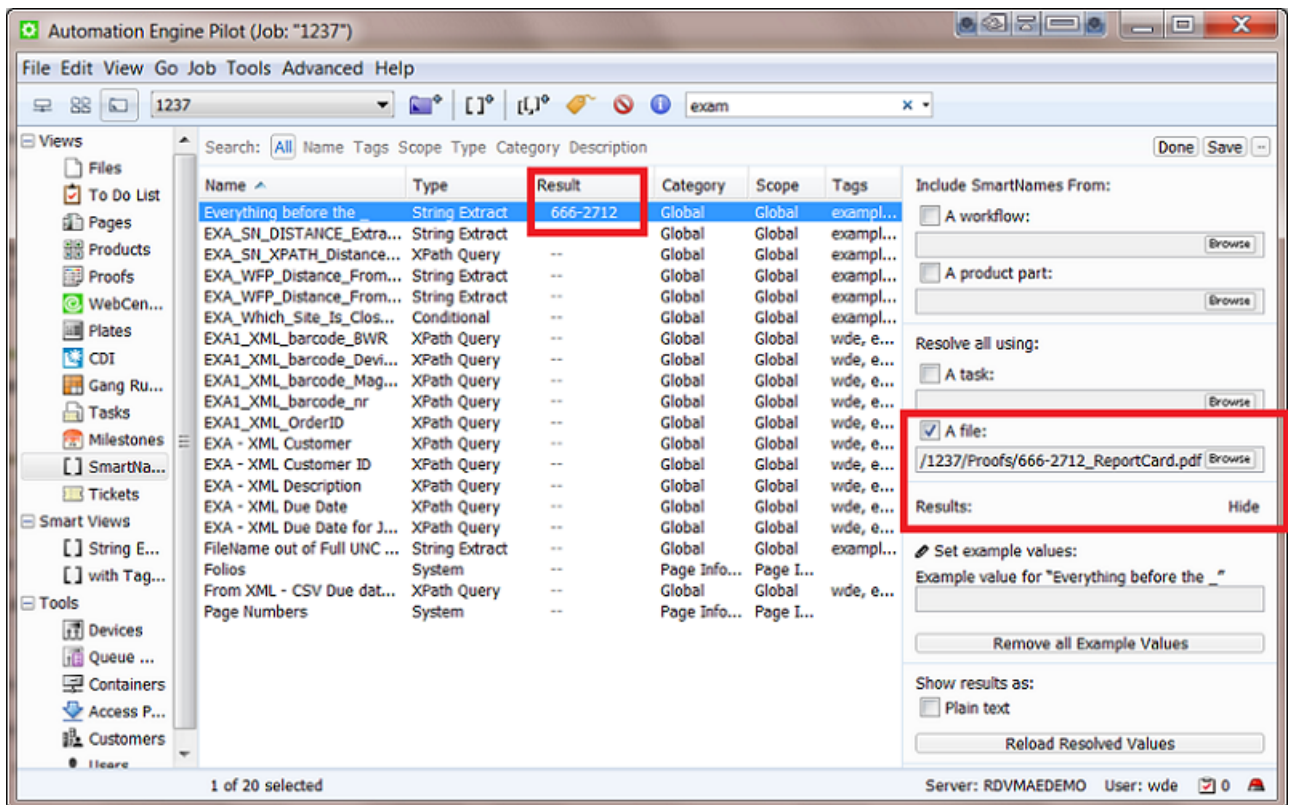

### Set example values

This is useful for SmartNames that have dependencies. For the selected SmartName, you can type in a manual value instead of needing to select a file or a task as input example.



**Tip:** Not all SmartNames allow you to enter an example value. This will for example work for most **System** type SmartNames and for the **CSV Text Extract** type SmartNames. This is because the value of these SmartNames is a "given" and can be overruled by your new example value. The value of SmartNames that are "calculated" can not be overruled ; the resolving mechanism will simply calculate them when needed.

See an example in the below screen shot.

- You made a custom SmartName [File - only part before \_], which is a string extract with the \_ (underscore) as separating character.
- This SmartName of course depends on the system SmartName [File]. If you then select the main SmartName [File], you will be able to set an example value.
- In our example, we enter the value "coco\_765869".
  - See how this value is shown as a manually entered example value: the  icon indicates this.
  - See how the SmartNames (that depend on the SmartName [File]), also react and resolve a value: the SmartName [File - only part before \_] results in 'coco'.

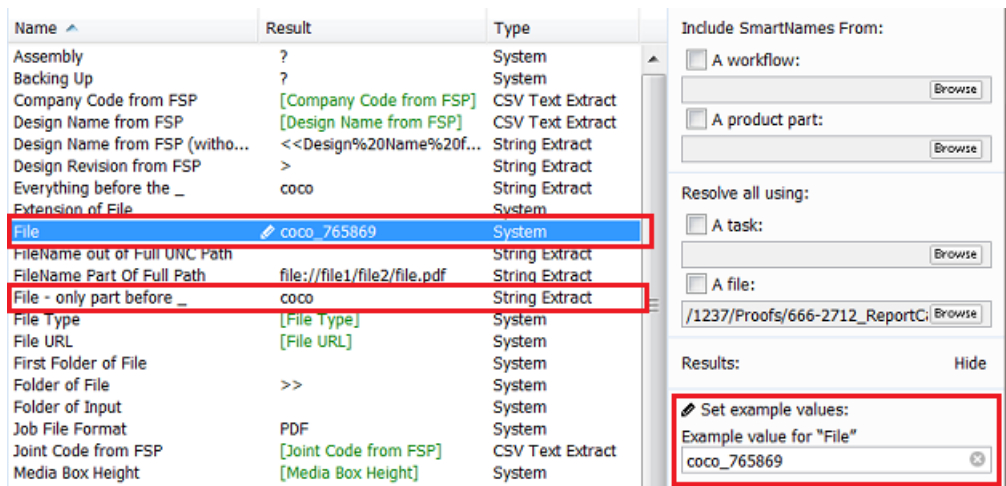

### Remove all Examples Values

Click this to remove all the example values from your SmartNames View.

### Show results as Plain text

In some exceptional cases it can be necessary to insert a SmartName although the user interface does not offer to insert this SmartName in this place. Use this function to see the SmartName as plain text so you can then select, copy and paste it anyway in the dialog or ticket where you really want it. Test carefully, because these cases are really exceptional.

A '**plain text**' version of a SmartName looks a bit like XML code. For example [Folder of File] is in plain text written as <<filefolder/>> and [Product Name] as <<bstpr:productname/>>.

### Reload Resolved Values

This 'refresh' function is useful when the input for you test has changed in the meantime.

For example you are setting up SmartNames that are reading parts of an XML file and you already did a test here. You typically want to test again after you know that the content of the XML file changed (your test will show new values).

## 9.2.9. SmartName Relations and Dependencies

In **SmartNames View**, when you right-click on one or on a selection of multiple SmartNames, you get these extra functions:



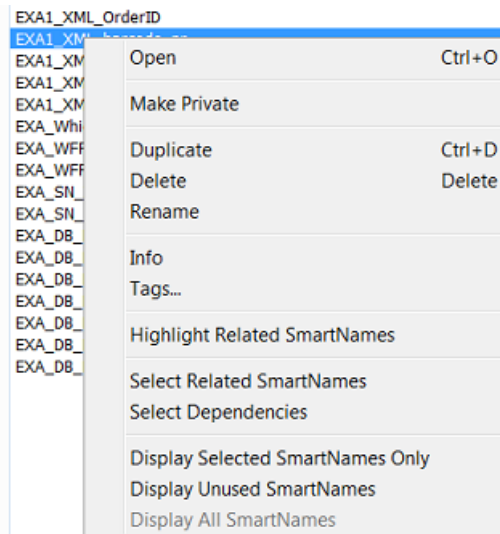

**Tip:** Most of those are also available from the **View** menu.



**Attention:** How SmartNames relate to each other is very important when you need to manage many of them. Such checks are very important especially when you plan to rename or delete a SmartName!

### Highlight Related SmartNames

Choose this function to **highlight** all SmartNames **that need one or more** of the currently selected SmartNames: 'Need' can mean that the one you selected is based on the other(s) or it can mean that the other(s) are based on the one you selected. This highlighting is a feature that stays active until you switch it off again.

For example: see this screen shot of the ones related to the SmartName [File]:



Name ^	Result	Type
Design Name from FSP	[Design Name from FSP]	CSV Text Extract
Design Name from FSP (without Revision)	<<Design%20Name%20from%20...	String Extract
Design Revision from FSP	>	String Extract
Everything before the _	[File]	String Extract
Extension of File		System
File	[File]	System
FileName out of Full UNC Path		String Extract
FileName Part Of Full Path	file://file1/file2/file.pdf	String Extract
File - only part before _	[File]	String Extract
File Type	[File Type]	System
File URL	[File URL]	System
First Folder of File		System
Folder of File	>>	System
Folder of Input		System
Job File Format	PDF	System
Joint Code from FSP	[Joint Code from FSP]	CSV Text Extract
Media Box Height	[Media Box Height]	System
Media Box Width	[Media Box Width]	System
n-th InputFile	0	System
Number of Pages	[Number of Pages]	System
Page Range	?	System
partOfFileNameBefore-	[File]	String Extract
pemy_BOX_DFile-id	[pemy_BOX_DFile-id]	Script
pemy_BOX_DFile-name	[pemy_BOX_DFile-name]	Script
pemy_BOX_File-etag	[pemy_BOX_File-etag]	Script
pemy_BOX_File-id	[pemy_BOX_File-id]	Script
pemy_BOX_FolderInfo-json	[pemy_BOX_FolderInfo-json]	CSV Text Extract

### Select Related SmartNames

Choose this function to select all SmartNames **that need one or more** of the currently selected SmartName. In this example [Fuel Cost] also gets selected because it [Fuel Cost no km] needs it (to extract the unit 'km').

Fuel Cost	--	Script
Fuel Cost no km	--	String Extract

### Select Dependencies

Choose this function to select all SmartNames **that are used in** the currently selected SmartNames. If you select the SmartName [Fuel Cost no km] in the example below and then activate **Select Dependencies**, the SmartName [Distance] will also get selected. This is because [Distance] is used in the definition of [Fuel Cost no km].

Name ^	Result	Type
Back	--	System
Distance	--	XPath
EXA_SN_DISTANCE_Extract_No_Units	--	String Extract
EXA_SN_XPATH_Distance_Incl_Unit	--	XPath Query
EXA_WFP_Distance_From_A_No_Units	--	String Extract
EXA_WFP_Distance_From_B_No_Units	--	String Extract
Fuel Cost	--	Script
Fuel Cost no km	--	String Extract
IWW distance to france	--	XPath

### Display Selected SmartNames Only

This function is no longer about selecting but about limiting the SmartNames that are displayed. This function helps when the selected ones are spread far out over your long list of SmartNames. See how the limited focus is also shown at the top.

Focused on 7 SmartNames   Search: All		
Name	Result	Type
EXA_DB_Myorders_CustomerID	--	XPath Query
EXA_DB_Myorders_CustomerName	--	XPath Query
EXA_DB_Myorders_DueDate	--	XPath Query
EXA_DB_Myorders_OrderNr	--	XPath Query
EXA_DB_Myorders_Process	--	XPath Query
EXA_DB_Myorders_ProofType	--	XPath Query
EXA_DB_Myorders_Status	--	XPath Query

When you want to see all your SmartNames again, then simply choose the function `Display All SmartNames`.

### Display Unused SmartNames

When it's time to cleanup your SmartNames you will want to know which ones are not being used (any more). Choose this function to display only the unused SmartNames. You will first get this warning dialog:

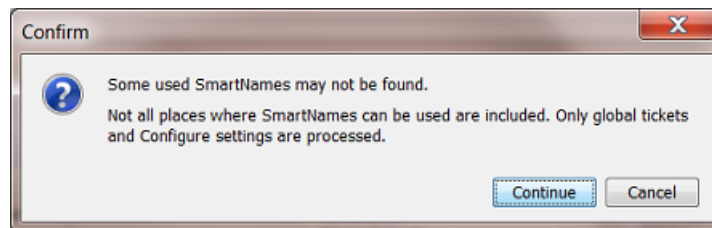

Press continue to start the search. When done, decide what to do with them (delete? tag as 'unused'?).

## 9.2.10. Exporting and Importing SmartNames

SmartNames can be exchanged by exporting and importing (workflow) tickets that use those SmartNames.

Learn more about exporting and importing (workflow) tickets in [Exchanging Workflows](#) on page 772.



**Attention:** SmartNames of *custom Job Parameters* ( [j.p. ] ) will not be imported. When you import a workflow that uses them, they will not be added into the job setup tab 'Parameters'.

### Why Exchange SmartNames?

Exchanging SmartNames is typically done

- with other people (during an Esko training or to send to Esko Customer Service).

- with other servers (colleagues that use another Automation Engine server in another plant of your company).

### How to Recover a SmartName that was Deleted?

Your SmartNames are a standard part of the Automation Engine backup data. When you want to restore SmartNames that were (accidentally) deleted, you can get them back by restoring a backup of that configuration. The deleted SmartName of course has to be part of that backup.

Learn more about backups and how to restore them in [The AE Server ADMIN web page](#) on page 2009.

## 9.3. System (Value) SmartNames

We will first list the default SmartNames of this type (**System SmartNames**), then show you how to create your own (**System Value SmartNames**) and end with some examples.

### 9.3.1. Default System SmartNames

We here describe the **System** type SmartNames that come with an install or update of your Automation Engine server.



**Remember:** In **SmartNames View**, the column **Description** already describes the SmartName briefly.



**Note:** Default System type SmartNames can not be changed. You can not double click and open them. You can not copy them. In some cases, it may help to create a new SmartName that uses a system SmartName and formats or extracts parts of the value it resolves to.

- **Access Point Customer, Access Point E-mail Sender, Access Point E-mail Subject, Access Point Host, Access Point Name, Access Point User:** These can all be used when using Access Points.
- **Access Point Path:** The path to the folder on the (S)FTP server that will be scanned.
- **Access Point Protocol:** Describes the used file transfer protocol. For example 'FTP' or 'GDRIVE' (for a Google Drive Access Point).
- **Application Name** and **Application Version:** Mentions the name and or the version of your Automation Engine software.
- **Assembly:** Assembly method as defined in the JDF file (`Assembly/@order`), only used in page imposition tasks.
- **Auto-Number1:** The main reason to use this SmartName is to add control over sorting the files in the workflow. If you choose as output file name `[File]_[Auto-Number1]` then each output file will get an (increasing) number. For example: your task input files are `banana, lemon` and `mango.pdf`. Then the output file names will be `banana_1.pdf, lemon_2.pdf` and `mango_3.pdf`.



**Attention:** This SmartName is only valid when the task has multiple input files and if those are grouped as one 'token'. This is often the case in page workflows. Learn more about tokens in [Understanding Tokens \(Grouping of Output Files\)](#). That page explains how you can group input files into one 'token' by using the [Data Collector](#).



**Note:** Notice that this SmartName is not related to version numbering!

- **Back:** The distance between the center of the back of the section and the trim box of the page (typically used to add collating marks to a page imposition).
- **Backing up:** The "backing up" method of the press (turn or tumble) as defined in the JDF file.
- **Book Name** and **Book Number:** Name and number of the book (**ImposeProof** only).
- **CDI Device Name:** Name of CDI device (used in the *Flexo views*).
- **CSR for the Job:** Name of the customer service representative handling the Job.
- **Customer's Product Reference:** Name that your customer gives to the Product item.
- **Customer's Job Reference:** Name that your customer gives to "his" job order.
- **Date:** The current date, formatted YYYYMMDD .
- **Device ID, Device Model Description, Device Model name, Device Model Number, Device Type:** As defined in the JDF file, used for page imposition "Stripping" tasks.
- **Distortion:** Horizontal or vertical distortion of the input file. This type of information can be found in PDF+ and normalized PDF files, incl. PDFPLA and SRT files.
- **E-mail Address of the CSR for the Job:** The e-mail address of the customer service representative for the Job.
- **Extension of File:** The extension of the input file.
- **File:** The name of the input file without extension.
- **File Type:** The file type of the input file, for example PDF or PDFSC (= Esko Normalized PDF).
- **Folder URL:** The URL of the folder of the input file, the full path. Formerly known as [File URL] .
- **First Folder of File:** The name of the first folder of the input file. For example: When the Folder URL is `file://aeserver01/ShareThatYouMadeContainer/FirstFolder/SecondFolder/banana.pdf` here, the **First Folder of File** is 'FirstFolder'.
- **Folder of File:** The name of the folder of the input file. In above example this is 'SecondFolder'.
- **Folder of First Input of Master Workflow:** Name of the folder of the input file of the most outer workflow.
- **Folder of Input:** The name of the folder of the input file (same as **Folder of File**).
- **Folio:** The page name of the current page (relates to **Mark Information**).
- **Folios:** A range of page names (folios) containing prefixes and suffixes (for example ~A~,~C~--~E~,~G~).
- **Imposition Name:** The name of the imposition (page workflows).
- **IMP Layer Names:** The names of the layers used in this sheet (used in page imposition workflows).

- **Ink Name:** The name of the ink(s)(relates to **Plate Information**).
- **JDF Device ID** and **JDF Device Name:** The ID and name of the machine or software (RIP or workflow) that interprets JDF.
- **JDF Sheet Name** and **JDF Signature name:** The sheet and signature name in the JDF file.
- **Job Category ...:** The category of the Job as defined in the Job setup, maximum 7 categories.
- **Job Colors:** The numbers of colors in the job (file) as found in the JDF file.
- **Job Colors Mode:** The Job color mode ('Black&White' or 'Full') as found in the JDF file.
- **Job Container Name:** The name of the **Container** where the Job has its **Job Folder**.
- **Job Container URL:** The URL of the **Container** where the Job has its **Job Folder**.
- **Job CT URL:** The URL of the "ct" folder of the Job (= where image files can be created during normalization).
- **Job Customer Contact 1, 2, 3:** The name of the 1st, 2nd and 3rd contact of the **Customer** of the Job.
- **Job Customer Description:** The description of the **Customer** of the Job.
- **Job Customer E-mail 1, 2, 3:** The e-mail address of the 1st, 2nd and 3rd contact of the **Customer** of the Job.
- **Job Customer ID** and **Job Customer Name:** The ID and name of the customer of the Job.
- **Job Customer Info 1, 2, 3, 4, 5:** The 1st etc.. info of the customer of the Job.
- **Job Description:** The description of the Job.
- **Job Due Date:** The due date of the Job (YYYYMMDD).
- **Job Due Time:** The due time of the Job (HHMMSS).
- **Job File Format:** The file format of the Job (standard format is Esko normalized PDF).
- **Job ID (internal)** and **Job Name:** The internal ID and the name of the Job.
- **Job Location:** The *location attribute* of the Job, used for pre-filtering data per user group.
- **Job Shared From:** Name of the location (the Esko Cloud Connection) that *shared* the job.
- **Job Temp URL:** The URL of the "temp" subfolder of the Job Folder.
- **Job URL:** The URL of the Job's **Job Folder**.
- **Layer Name:** The name(s) of the layer(s). Category 'Page Info'(used in page imposition workflows)
- **Layer Names:** The names of all layers in the input PDF or ArtPro file, separated by a pipe symbol (|). This information is the same as the one shown in a file's Info dialog.
- **Layer Number:** The number(s) of the layer(s).
- **Local Server:** The name of the server where the task runs.

- **Margin:** Left, right, bottom and top margin of the first page of the input file. Many file types contain such 'box' type information: PDF files, ArtPro files, and several image file types. This information is the same as the one shown in a file's Info dialog.
- **Mark Height** and **Mark Width:** Height and width of the current mark.
- **Master Server:** Name of the Automation Engine master server. This is the one that runs the "task manager".
- **Media Box Height** and **Media Box Width:** The height and width (mm) of the Media Box of the first page of the input file.
- **Merged Plate Name:** The name of the same as the CDI Job name, ending with an extension ".par". This is also the name as it appears in the queue of the CDI's "Expose" application. This name is defined in the [Create Merged Plate task](#).
- **Name (without extension) of originating Input of (enclosing) Workflow:** The name of the first input of the (enclosing) workflow.



**Note:** The "enclosing workflow" is the workflow that the task, in which the SmartName is used, is part of.

- **Name of first Input of Master Workflow:** The name of the first input of the (most outer) workflow.
- **Name of Folder of Job:** The name of the **Job Folder**.
- **Name of Folder of originating Input of (enclosing) Workflow:** The name of the *folder* of the first input of the (enclosing) Workflow.
- **Name of originating Input of (enclosing) Workflow:** The name of the first input of the (enclosing) Workflow.
- **n-th Input File:** The index number of the input file (the how many'th it is).
- **Number of Pages:** The number of pages of the input file.
- **Number of Pages (RunList):** The number of pages in the **RunList**.
- **Operator:** The Automation Engine user that launched the task.
- **Order ID:** The Order ID of the Job.
- **Output Intent:** The output intent of the input PDF file. This type of information can be found in PDF+ and normalized PDF files (including PDFPLA and SRT files). This info is the same as the one shown in the file's Info dialog, there named 'document color profile'.
- **Padded Page Label:** The page label padded with zeros (extra zeros in front).
- **Padded Page Number:** The page number padded with zeros (extra zeros in front). Only used in the **Split Pages** task.
- **Page Label:** The label of the page. Only used in the **Split Pages** task.
- **Page Height:** and **Page Width:** The vertical and horizontal trim size of the page.
- **Page Number:** The page number (starting from 1) or page range if the 'One Ups' contain more than one page.

- **Page Numbers:** A range of page numbers. For example: 1–5, 7, 9–11 .
- **Page Range:** The range of imposed pages available in the output file (**ImposeProof** only).
- **Paper Height** and **Paper Width:** The vertical and horizontal size of the paper (page workflows).
- **Plate Height** and **Plate Width:** The vertical and horizontal size of the plate (page workflows).
- **Plate Template Name:** The name of the plate template (page workflows).
- **Press:** The name of the press as defined in the JDF file (Device/@FriendlyName or Device/@DeviceID).
- **Print Group Name:** The name of the print group (collection of sheets) or sheet. This is used in (Black & White) page workflows.
- **Print Order:** Print order of the separations of the input file, i.e. If and how Printing Units were defined in the file. Values can be **Undefined** (default), **Normal** (= as the order of the separations), **Reverse** or **Invalid**. This SmartName makes it possible to check in a workflow if the file has printing units defined and if they imply a normal or reverse printing order. Learn about Printing Units in the [ArtPro+ user guide](#) (in **Documents** > **Separations** > **Working with Printing Units**).
- **Product Customer Description, Product Customer ID** and **Product Customer Name:** The description, ID and name of the customer for that **Product**.
- **Product Custom Field 1, 2, 3:** The custom field 1, 2 and 3 of the **Product**.
- **Product Description, Product ID** and **Product Name:** The description, ID and name of the **Product**.
- **Product Ordered Copies:** The amount of ordered copies that were ordered of this **Product Part** in this Job.
- **Product Part Custom Field 1, 2, 3:** The custom field 1, 2 and 3 for the **Product Part**.
- **Product Part Data Zone:** The URL of the **Data Zone** of the **Product Part**.
- **Product Part Name:** The name of the **Product Part**.
- **Product Part Status:** The status of the **Product Part** (the Esko system name).
- **Project ID:** The Project ID of the Job.
- **Right Margin:** Right margin of the first input file.
- **RunList Name** and **RunList Number:** The name of the RunList and its number in the imposition.
- **Section Number:** The number of the section, starting from 1 (this is related to **Marks**).
- **Separation Names:** Names of the separations in the input file, in one string separated by a pipe symbol (|).



**Note: Artwork Separations** are the regular printing separations, i.e. those with type 'normal' or 'opaque'. In a file's Info dialog, artwork separations are shown with a square color patch. Those shown with a round color patch are colorants of processing step layers. Learn more [in the ArtPro+ user guide](#).

- **Artwork Separation Names:** Names of the artwork separations in the input file.
- **Long Artwork Separation Names:** Long names of the artwork separations in the input file.
- **Long Separation Names:** For example B1ack i.s.o. K, or PANTONE 803 C i.s.o 803.
- **Number of Artwork Separations:** Number of artwork separations.
- **Number of Separations:** Number of separations (or inks) in a PDF file, ArtPro, GR\* file or various image file formats.
- **Server:** The name of Automation Engine's (**Master**) Server.
- **Sheet Colors** and **Sheet Colors Mode:** The number of colors in the sheet and their color mode ('Black&White' or 'Full'), as found in the JDF file (page workflows).
- **Sheet Descriptive Name:** A short description of the sheet as defined in the JDF file (StrippingParams/@DescriptiveName), used in page workflows.
- **Sheet Index:** The index of the sheet (starting from 0), used in page workflows.
- **Sheet Name** (scope 'Stripping'): The name of the sheet as defined in the JDF file (StrippingParams/@SheetName), used in page workflows.
- **Sheet Name** (scope 'Plate Information'): The name of the sheet, used in page workflows.
- **Sheet Number:** The number of the sheet (starting from 1), used in page workflows.
- **Sheet Side:** The side of the sheet: Front or Back (used in page workflows).
- **Sheet Side SmartID:** The **SmartID** of the sheet side (a calculated identification number).
- **Short Task ID** and **Short Workflow Task ID:** The short version of the task ID number and the (most outer) workflow task ID number. For example: '5439'.
- **Signature Name:** The name of the signature as defined in the JDF file (StrippingParams/@SignatureName), used in page workflows.
- **SmartID:** The **SmartID** of this file's version (identification number calculated from a combination of an identifier of the file itself and of its external references).
- **Stripping Part Number:** Stripping part number as defined in the JDF file, used in page workflows.
- **Sub Order ID:** The sub order ID of the Job.
- **System Defined:** The is used when outputting .imp files (page impositions). It is a combination of the imp name, sheet number, sheet side and layer name.
- **Task ID (internal):** The ID of the task in Automation Engine, the long version. For example: 'afbdf6ac-8d82-4eee-af4d-b2408041640f'.
- **Task Name:** The Esko system name of the task (workflow) ticket. For example the **Add SmartMarks** task is called "batchbrix.smartmarks".



- **Task Owner E-mail:** The e-mail address of the owner of the task.
- **Technical Inks in Browser Client:** A comma separated list of the technical inks as defined in the Automation Engine browser client. This SmartName is used internally.
- **Ticket Name:** The name of the ticket of the task (the name you gave the ticket).
- **Time:** The current time (when the SmartName is calculated), formatted HHMMSS.
- **Trim Box Height** and **Trim Box Width:** Height and width of the Trim Box (mm) of the first page of the input file.
- **URL of first Input of Master Workflow:** The URL of the first input file of the (most outer) workflow.
- **URL of Folder of Input:** The URL of the *folder* of the input file.
- **URL of Folder of originating Input of (enclosing) workflow:** The URL of the folder of the first input of the (enclosing) workflow.
- **URL of Input:** The URL of the input file.
- **URL of originating input of (enclosing) workflow:** The URL of the first input of the (enclosing) workflow.
- **Variant Name** and **Variant Number:** The name(s) and number(s) of the variant(s) (used in page imposition workflows).
- **Web** (scope 'Imposition'): The index of the web in the print group (used in page workflows).
- **Web** (scope 'Plate Information'): The number of the web (for multi-web printing in page workflows).
- **Workflow Task ID (internal):** The ID of the (most outer) workflow task.
- **Work Method:** The working method for 'backing up' Back to Front (page workflows).
- **Work Style:** The name of the work style defined in the JDF file (StrippingParams/@WorkStyle).

### 9.3.2. Creating System Value SmartNames

As we introduced in [SmartName Types \(Overview\)](#) on page 644, a **System SmartName** is a query to one of Automation Engine's own databases. Think of it as a question to Automation Engine.

As you can see in [Default System SmartNames](#) on page 661, there are already a lot **Default System SmartNames**. Still, there are still some cases where it makes sense to create your own extra **System Value SmartNames**.

#### Concept

When creating your own **System Value SmartName**, your question can be one of these 3:

- "Give me the Job URL, the full network path to the Job's Job Folder"
- "Give me the Product Part URL, the full network path to the Product Part file"
- "Give me the Product Part Data Zone URL, the full network path to the Product Part Data Zone"

These questions usually come up in these 2 cases:

- when you receive a file and you want to store it in a Job or Product related folder
- when you want to get a file from (under) those places.

In both cases, you need to add 1 or more parameters in your question that you do know. For example: "Where is the Job Folder if I tell you that the Order ID is 12345 and the Customer ID is 67888 ?"



**Note:** In a perfect world, you have a perfect data structure that is very logic and it never changes. Then you would maybe not have these questions. However, it can for example happen that your data **Containers** fill up and you may not be sure on which one the Job Folder was created. Or the files that you receive need more analysis to interpret where they belong to.

### Creating a System Value SmartName - Generic Steps

We here only show the basic generic steps to create such a SmartName. See further for 3 specific examples.

1. In the **SmartNames View**, click on 
2. Choose the **Type 'System Value'**.
3. Choose a **Scope**. If you are not sure, choose **Global**. Learn more about [SmartName Scopes](#) on page 648.
4. **Which System Value:** choose the type you are you are looking for.  
A list of attributes will appear. These will help to find what you want.
5. Check the attribute(s) **that you do know**, one could be enough.
6. Enter the value of each checked attribute. This will probably also be a SmartName.  
You obviously need to prepare these SmartName(s) first.
7. Check the **Result** value already shown below left. This will only be possible when you are in **SmartNames View** and are using the **Resolve all using** tool. Learn more in [Test your SmartNames with 'Resolve All Using'](#) on page 655.
8. Click **Save as...** to save your SmartName.

### Example of Looking for the Job URL

#### Example: Finding the Job URL by using the name of an incoming design file

- You have created a Job '1237' and you are waiting for the customers design file.
- You receive a design file via E-mail or FTP. Your customer does not know what Job name you already created. The name of the design file is '78999\_Banana.pdf'. This name starts with how the *customer* names this job/design: the **Customer's Job Reference**, followed by a free name reflecting the design variant (here the *banana* flavor).
- The setup of your Job '1237' also includes this **Customer's Job reference** '78999' (this information came in earlier via your business system).
- You created a SmartName 'EXA FILE\_ALLBEFORE\_', a **String Extract SmartName** that extracts from a file name all characters before the '\_'. Learn more in [String Extract SmartNames](#) on page 671.
- Your **System Value SmartName** SmartName now needs the settings as in this screen shot:

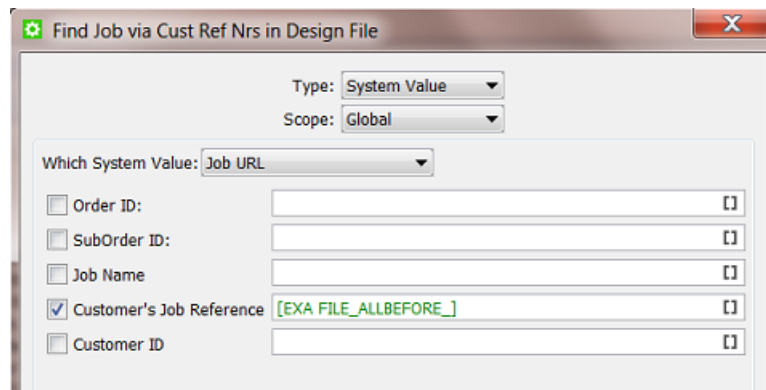

- Save your SmartName with a logical name. For example 'Find Job via Cust Ref Nrs in Design File'.

### Example of Looking for the Product Part URL

#### Example: Finding the full Product Part URL by asking the Product ID

- Your business system sends you an XML with a list of product items on which you need to launch a workflow.
- Business systems often do not know how your prepress data is structured. The XML mentions the **Product ID** but does not know the exact path to that **Product Part**. So you need to find out that URL.
- For example, we look for the full URL of the Product ID '12345'. What the business system does not know is the folder and the name of the PDF. The PDF name is 'tomato\_juice.pdf', it has no reference to the **Product ID**.

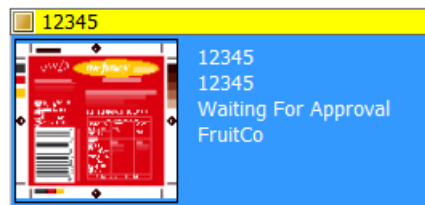

- You first need to create a SmartName that extracts the **Product ID** from the XML. See this example:

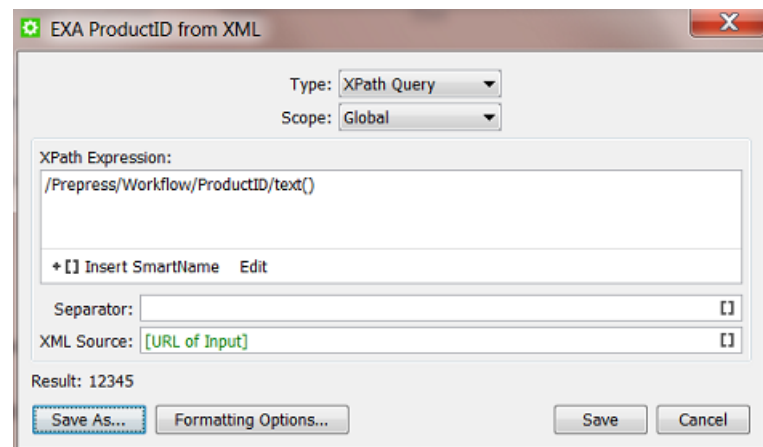

Learn more about extracting values from an XML file in [XPath Query SmartNames](#) on page 676.

- Your **System Value SmartName** then uses that **Xpath Query SmartName**:

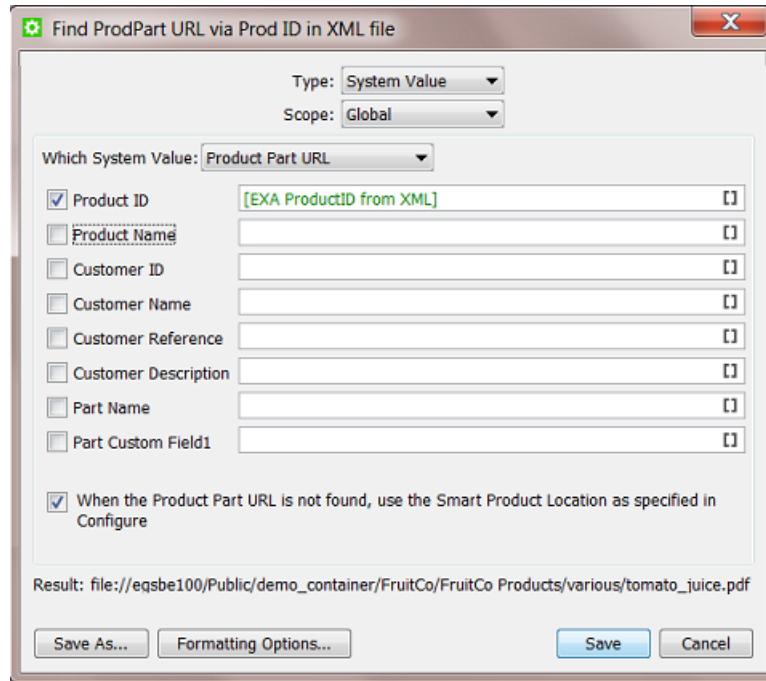

See (below left) how the **Result** shows the complete URL to the PDF. This is what we were looking for.

- Save your SmartName with a logical name. For example 'Find ProdPart URL via Prod ID in XML file'.

### Example of Looking for the Product Part Data Zone URL

#### Example: Finding the Product Part Data Zone URL by using the name of an incoming design file

- You have a workflow where you business system creates new **Products** on your Automation Engine, even *before* the design file has arrived.
- One of those is the **Product** '6662712\_Yolo\_Juice' that is waiting for its design (and has no thumbnail display yet). The number before the underscore is the product ID.

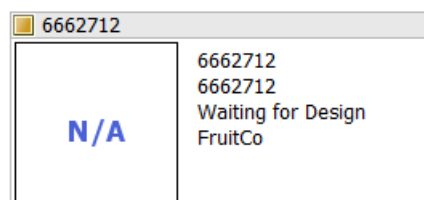

- You have a **Folder Access Point** (or E-mail or FTP or WebCenter) that you scan for incoming designs.
- When a design comes in, you first want to copy it to the right destination: to its **Product Part Data Zone**.

- You need a **System Value SmartName** as in this screen shot:

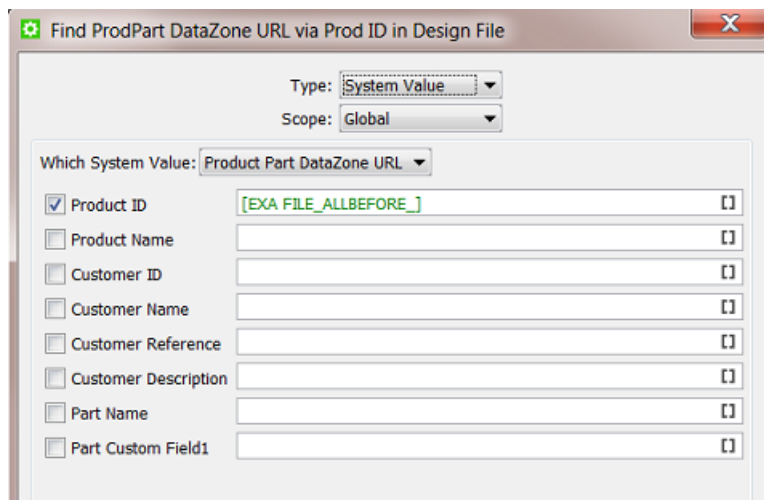

- Save your SmartName with a logical name. For example 'Find ProdPart DataZone URL via ProdID in Design File'.
- Your **Copy or Move File** ticket now uses this SmartName:

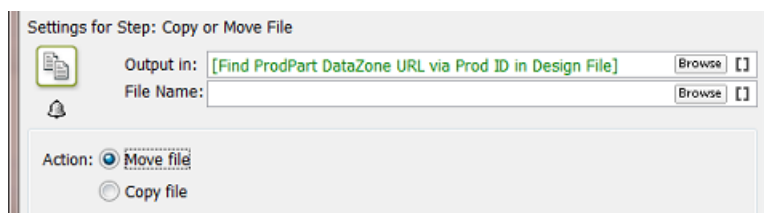

- You probably want to continue your workflow with the **Manage Product Status** task to change the status of this **Product Part** to 'Design File Arrived'.

## 9.4. String Extract SmartNames

When automating your workflow, you will quickly feel the need to extract a part of a file name or a network path. **String Extract SmartNames** offer to do just this.



**Note:** A **String** is a series of characters. These can be numbers, text or even symbols.

### 9.4.1. Creating a String Extract SmartName

To create a **String Extract SmartName**, follow these steps:

- In **SmartNames View**, click on .
- Choose the **Type 'String Extract'**.
- Choose a **Scope**. If you are not sure, choose **Global**. Learn more about [SmartName Scopes](#) on page 648.

4. In **Extract part of...**, decide *from what* you will extract something. In the canvas, you can
- type. This is mostly done to test your SmartName while creating it (you see the result below left)
  - insert **SmartNames**. This is the most typical use, for example to extract parts of a [File] or a [Folder URL].
  - right-click and choose an option: **Cut, Copy, Paste, Clear Contents** or **Insert SmartName**.

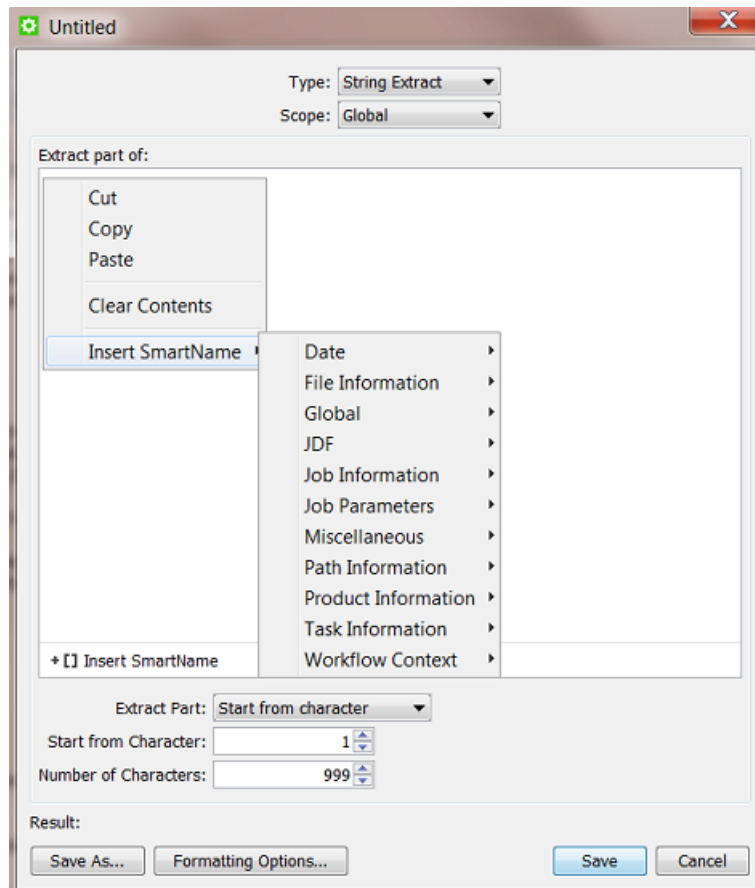

5. Define *what* you want to extract. Choose from these 3 methods:
- **Start from character**. Learn more in [Start From Character](#) on page 673.
  - **Use separation character**. Learn more in [Use Separation Character](#) on page 673.
  - **Use regular expression**. A "Regular Expression" is a standard language in computer science. It enables very specific ways to extract parts of a string. Learn more in [Using Regular Expressions](#) on page 702.



**Attention:** Results can vary if your input string is considered as a text or as a number! This is decided in the **Formatting Options**. The default is that your string is assumed to be text. Learn more about this in [Formatting SmartNames](#) on page 696.



**Note:** The **Result** will update itself only after you changed a setting or clicked somewhere in a different field. Tip: press the 'Tab' button to make sure that the **Result** is re-calculated.

- Click **Save** to save your SmartName and close the dialog. Click **Save As...** to save your SmartName but keep the dialog open (to create more SmartNames).

### Start From Character

This method allows to decide the start and end character that you extract. Some examples:

#### Example 1: "First 5"

Your input string is '874095620banana' and you want to extract the first 5 characters.

Choose **Start from character**. For **Start from Character** choose '1' and for **Number of Characters** choose '5'. This will result in '87409'.



**Note:** This method is mostly used to extract the *first* characters of a file name. To extract the *last* part of a file name, you need to use **Regular Expressions**. Learn more in [Using Regular Expressions](#) on page 702.

#### Example 2: "All except the first 3"

Your input string is '8740956202537435'. You want to extract all of the characters except the first 3.

Choose **Start from character**. For **Start from Character** choose '4' and for **Number of Characters** leave the default setting to '999'. This will result in '0956202537435'.

### Use Separation Character

This method allows to separate the string into parts every time a certain **Separation Character** occurs, and extract one of the parts.

You can choose a **Separation Character** from the list but you **can also type in a different one**.

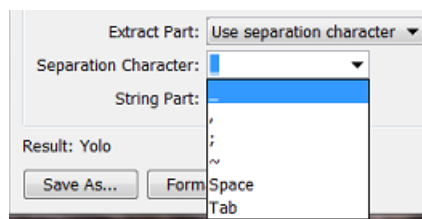

The **String Part** is where you choose which part of the string you want to extract.

#### Example 1: "Everything before the (first) underscore"

Your input string is '12345\_678901' and you want to extract everything before the underscore '\_'.

Choose **Separation Character** '\_' and set the **String Part** to '1'.

This will result in '12345'.

**Example 2: "The 3rd part"**

Your input string is '87409\_5620\_27\_923' and you want to extract the number '27' which is the 3rd part of the string (if you separate it with the '\_').

Choose **Separation Character** '\_' and set the **String Part** to '3'.

This will result in '27'.



**Note:** If you want the part after the **last** '\_', then this is not possible using the **Use separation character**. To do that, you need to use the method **'Use regular expression'**. Learn more in [Using Regular Expressions](#) on page 702 .

**Example 3: "Everything after the '@'"**

Your input string is 'Franky.Fruit@FruitCo.com' and you want to extract everything after the '@'.

In **Separation Character**, type in '@' and set the **String Part** to '2'.

This will result in 'FruitCo.com'.

**Use Regular Expression (link)**

Learn all about **Regular Expressions** in a separate section of this chapter, in [Using Regular Expressions](#) on page 702.

## 9.5. CSV Text Extract SmartNames

---

A **CSV Text Extract SmartName** allows you to create a SmartName that finds a value in a specific field of a CSV file. We will first illustrate the generic steps to create such a SmartName and then show a concrete example.



**Note:** Although the name of this SmartName type contains the word 'text', the value that is extracted can also be a number or any other character type.

### 9.5.1. Creating a CSV Text Extract SmartName

To create a **CSV Text Extract SmartName**, follow these steps:

1. In **SmartNames View**, click on .
2. Choose the **Type 'CSV Text Extract'**.
3. Choose a **Scope**. If you are not sure, choose **Global**. Learn more about [SmartName Scopes](#) on page 648.
4. Define where your CSV can be found and set some options:
  - **CSV Source:** Define the path and name of the CSV file. You typically use SmartNames here.



- **Text Encoding:** Indicate the **Text Encoding** of the CSV file. The default encoding is Unicode UTF-8.
  - **Field Separator:** Indicate which character is used to separate the fields in the CSV. If you're not sure, open your CSV in a simple text editor.
  - **Quote Character:** Indicate if the value in the CSV contains quotes that you do not want to keep. For example: in the CSV a value is written as "25000" but you want to extract only the 25000.
  - **Ignore line breaks:** Check this option if the CSV only contains one record (column).
  - **Ignore first line:** Check this option if the first line of the CSV contains the names of the columns. Use **Select Field...** to preview the effect of this.
5. Define which specific field in the CSV you want to extract.
- Type the number of the field and line in **Extract text from field ... on line ....**
  - or click on **Select Field...** to get a preview of your CSV file and there click the field you want to extract. The field and line number will then be entered automatically.



**Note:** A preview of your CSV file will only appear if the field **CSV Source** can already find your CSV input file.

6. Check the result in **Result**.
7. If needed, set any **Formatting Options**. Learn more in [Formatting SmartNames](#) on page 696.
8. Click **Save** to save your SmartName and close the dialog. Click **Save As...** to save your SmartName but keep the dialog open (to create more SmartNames).

## 9.5.2. Example

- You are working with the **Products** tool and have set up some integration with your business system. You have set up a workflow where your **Jobs** are created automatically.
- You also get (from another system) a CSV file with the ordered copies (amount) that a **Product** is to be produced in that Job context. The CSV is written in the **Job Folder**, in a subfolder **CSV** and with a specific name. The screen shot shows how the **CSV Text Extract SmartName** can be set up:

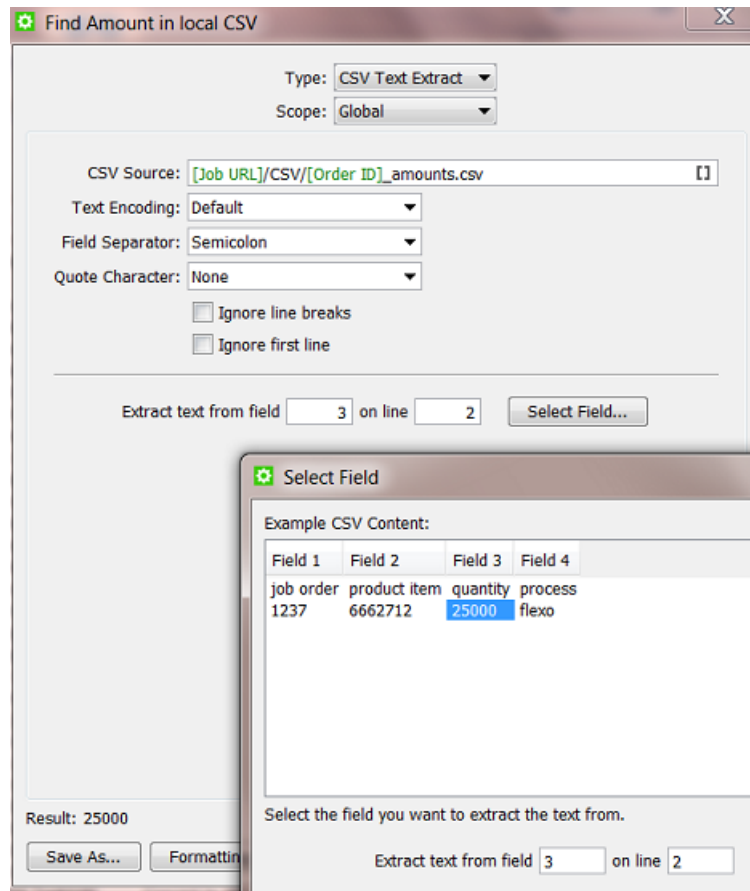

- This SmartName [Find Amount in local CSV] can now be used in your automated workflow where you use the **Link Product to Job** task.

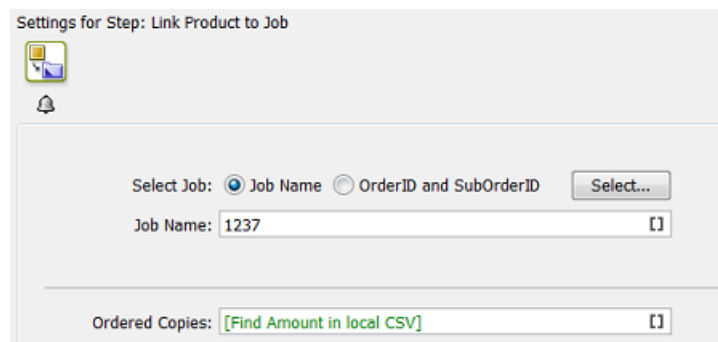

## 9.6. XPath Query SmartNames

As mentioned in [SmartName Types \(Overview\)](#) on page 644, **XPath Query SmartNames** use "XPath queries" to extract a value from an XML file. XPath, the XML Path Language, is a standard query language for selecting nodes from an XML.

In Automation Engine, there are many tasks that can read parts of an XML, often without the need to create a SmartName first. You can there directly enter an 'inline' XPath expression in the ticket's input field. See for example the [Create Job task](#).



**Tip:** Many of such tasks and tools are described in the chapter [Integrating with External Systems](#) on page 1769.

To help you build such XPath queries, **Esko** offers the [The XPath Builder](#) on page 678. This tool is available throughout Automation Engine, wherever you can create XPath queries.

### 9.6.1. Creating an XPath Query SmartName

To create an **XPath Query SmartName**, follow these steps:

1. In **SmartNames View**, click on .
2. Choose the **Type 'XPath Query'**.
3. Choose a **Scope**. If you are not sure, choose **Global**. Learn more about [SmartName Scopes](#) on page 648.
4. The large canvas is where you define your **XPath Expression**. Initially, there is an example expression about `'vsize'`. It will be removed automatically when you have used the **Edit** button and created your own. In this canvas, you can:
  - Type an XPath expression (if you know how to do this).
  - Click on **Edit** to open the **XPath Builder**. This tool helps you create an Xpath expression. Learn more in [The XPath Builder](#) on page 678.
  - Click on **Insert SmartName** to insert SmartName(s) into your XPath expression. This is in most cases not needed.
  - Right-click and choose an option: **Cut**, **Copy**, **Paste**, **Clear Contents** or **Insert SmartName**.

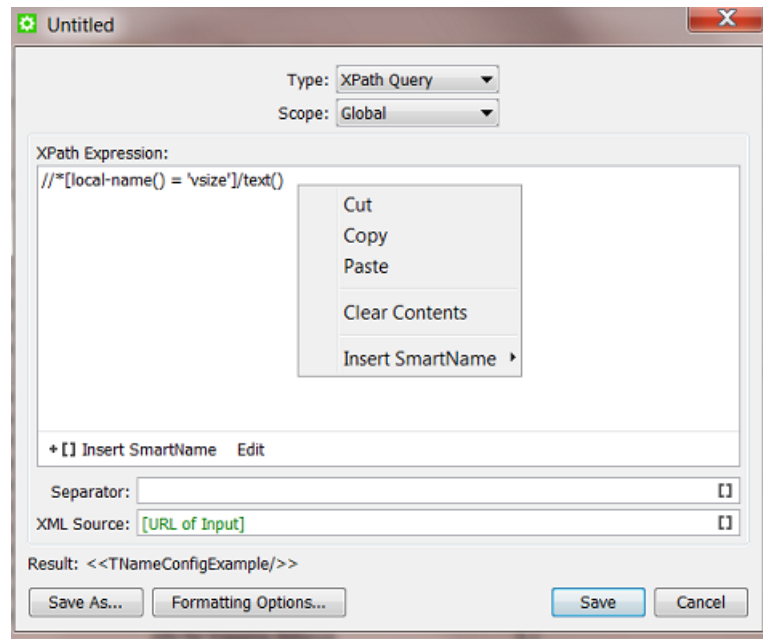

5. **Separator:** If the **XPath Expression** returns multiple elements, decide what character you want to use as separator.
6. **XML Source:** Define the path and name of the XML. Or keep the default SmartName [URL of Input].
7. **Result:** See the result of your **XPath Expression**. This is possible when the **XML Source** can be found. The **Result** is also visible when you are in **SmartNames View** and are using the tool **Resolve all using** and have manually selected an example XML. Learn more in [Test your SmartNames with 'Resolve All Using'](#) on page 655.
8. **Formatting Options:** Learn more in [Formatting SmartNames](#) on page 696.
9. Click **Save** to save your SmartName and close the dialog. Click **Save As...** to save your SmartName but keep the dialog open (to create more SmartNames).

## 9.6.2. The XPath Builder

### Introduction

**XPath** is a language that describes how to locate elements and attributes in XML (Extensible Markup Language) files. You can find a full specification on <http://www.w3.org/TR/xpath/> and a tutorial on <http://www.w3schools.com/xpath/>.

Think of an **XPath Query SmartName** as a **String Extract SmartName** but then to get a string from an XML file.

The **XPath Builder** is an XML editor available in the Pilot. Anywhere in the Automation Engine where there is a field that allows an **XPath Expression**, you can access the **XPath Builder** by clicking on its icon .



**Note:** If you are an expert in building XPath expressions, you can also directly type XPath expressions in this field. The syntax for doing this is "XPath:" followed by a valid XPath expression for the input file. Example: `xpath:/Orders/Job/Longname`

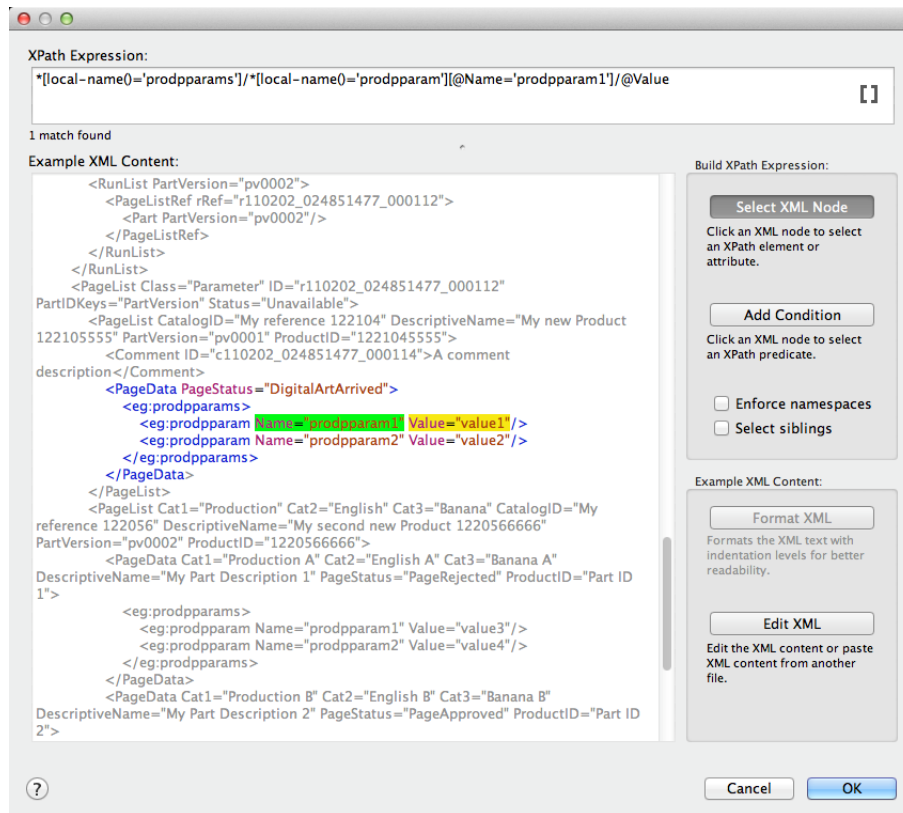

### The XPath Builder panel



- On top of the panel, you see the resulting **XPath Expression** that is probably a result of what you have clicked below.



**Attention:** This top field also offers to add SmartNames to this expression (see the icon on the right).

- Adding SmartNames to your XPath expression is only supported when you use this tool while you are creating a SmartName (see [Creating an XPath Query SmartName](#) on page 677).
- Adding SmartNames to your XPath expression is not supported when you are creating an 'inline' XPath expression. Several tasks allows this and show this by offering an  icon in that field. For example the [Create Job task](#). It does not matter if you type that SmartName in yourself or click  to use this Builder tool to add it to your XPath expression.

- The large canvas shows the **Example XML Content**.
  - When possible, the example XML is automatically taken from the context. For example when you open the **XPath builder** from the **XPath Query SmartName** dialog, then the input file is used as an example XML.
  - When no example XML is available automatically, right-click in the canvas to see these extra ways to get and manage XML content: **Cut**, **Copy**, **Paste**, **Clear** and **Paste from File...**

- Use CTRL-F (Windows) or CMD-F (Mac) to open a **Find** tool. This is very handy when your XML is a large file and you quickly want to find the string you want to select.



**Note:** This area has XML syntax highlighting: specific colors indicate a specific kind of node.

- On the right you have tools that help you create the **XPath Expression** by offering smart selections and even help you edit the XML content.

## Building XPath Expressions

### Select XML node

To build an **XPath Expression**, make sure that the **Select XML Node** button is clicked.

Simply click on an XML node to automatically create an XPath to that node. The resulting XPath is shown in the **XPath Expression** field at the top.



**Note:**

- The created XPath will be an "absolute XPath" from the root node to the selected node.
- The selected node will be highlighted in yellow.
- When the selected node is used in a list, an index number will be used in the XPath. For example: `/PurchaseOrders/PurchaseOrder[1]/Address[2]/Street/text()`.
- The generated XPath takes **namespaces** into account by using the **local-name** function. For example: `/*[local-name()='PurchaseOrder'][@*[local-name()='PurchaseOrderNumber']='99503']/*[local-name()='Address'][@*[local-name()='Type']='Billing']/*[local-name()='Street']/text()`



**Note:** By selecting **Enforce namespaces**, the XPath Builder will verify any used namespace.

### Add Condition

To add certain conditions to the XPath, click **Add Condition**. Then click on the desired XML node to add it as a 'predicate' to the **XPath Expression**.



**Note:**

- You can also add a condition by clicking on the desired XML node while holding the Alt key.
- The predicate nodes are highlighted in green.
- When using predicate nodes, the indices in the XPath are replaced with predicates. For example: `/PurchaseOrders/PurchaseOrder[@PurchaseOrderNumber='99503']/Address[@Type='Billing']/Street/text()`.
- When using predicates, it is possible that the **XPath Expression** selects multiple XML nodes. The number of matches is displayed beneath the **XPath Expression**.

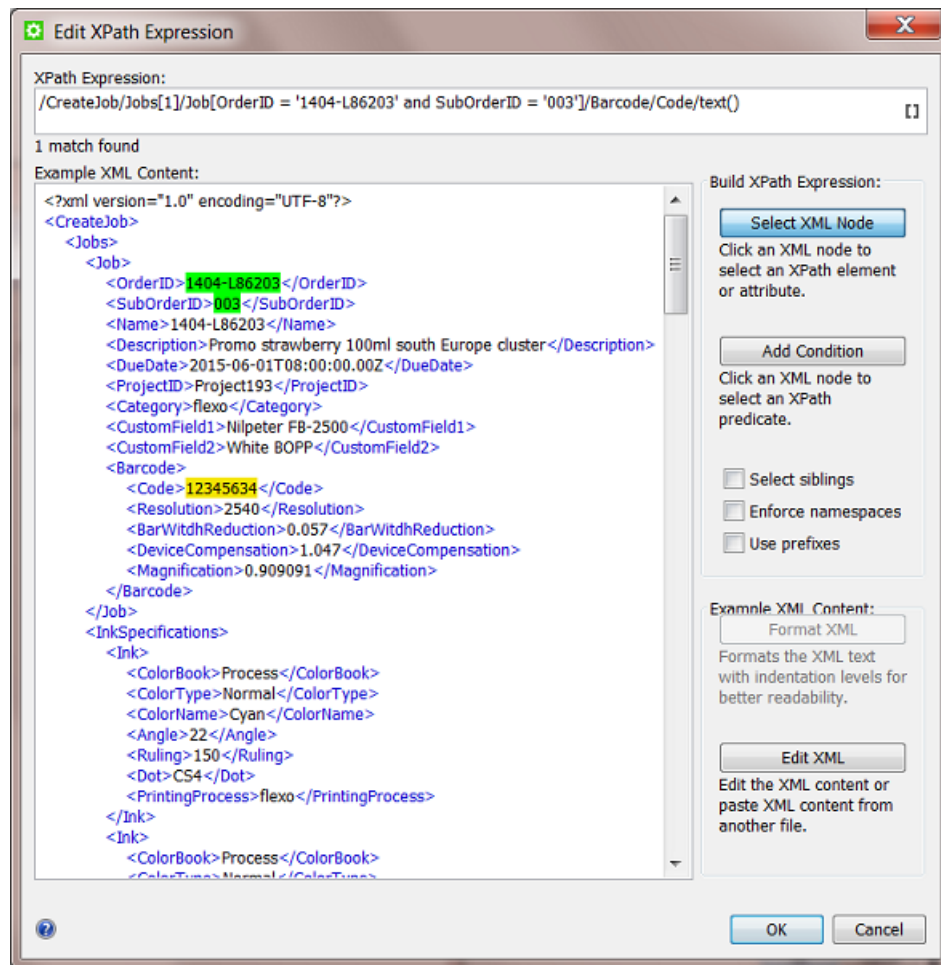

**Options**

- **Select siblings.** Select this option to select all occurrences of the selected element at this level.



**Tip:** This option is especially relevant when working with 'repeating content' in the *Map data task*. You there need to **Select siblings** to avoid that only the first element would be repeated (you would so get a list of only 1).

- **Enforce namespaces.** Select this option to enforce **XML namespaces** ('xml:ns').



**Tip:** **XML namespaces** provide a method to avoid element name conflicts. In XML, element names are defined by the developer. This often results in a conflict when trying to mix XML files from different XML applications.

- **Use prefixes.** Check this option if you want to use **XML namespaces** in your **Xpath Expression** in a shorter way.



**Note:** This option overrules the option **Enforce namespaces**.



**Tip:** This option is especially useful when querying XMP.

## Editing Example XML Content

### Format XML

Under **Example XML Content**, click on **Format XML** to format the example XML. This can be used to make the XML more readable. It will typically remove unnecessary spaces and lines.

### Edit XML

To edit the example XML, follow these steps:

1. Under **Example XML Content**, click on **Edit XML**.



**Note:** This will make the XML content editable. Also, the buttons **Revert** and **Apply** will become visible.

2. Edit the XML in any way you want.
3. When finished making changes, click **Apply**.



**Note:** The changes will be automatically validated. If the XML is not valid, an error message will appear and the location where the parse error occurred will be visible and highlighted in a red color.

4. Before you click **Apply**, you can click on **Revert** to undo *all* changes made to the XML content.



**Note:** You can undo/redo the last edits using (on Windows) Ctrl-Z and Ctrl-shift-Z or (on Mac) Command-Z and Command-Shift-Z.



**Note:** If you clicked **Apply** but did this in error, you can still click **Cancel**.



**Note:** It is also possible to edit the **XPath Expression itself** manually. When you do this, take the following into account:

- After editing the XPath, press **Enter** to validate the updated **XPath Expression**.
- If the updated **XPath Expression** is not valid, an error message will be displayed beneath the **XPath Expression**.
- The corresponding XML nodes will be highlighted in grey.

## 9.7. XMP XPath Query SmartNames

XMP stands for 'eXtensible Metadata Platform'. It allows embedding data *about* a file, known as metadata, *into* the file itself. It is a standard defined by Adobe.

Esko also uses XMP as format for metadata in many of its processed files (Normalized PDF, View data, LEN and other RIP output).





**Important:** When Automation Engine processes native PDF files (so including **PDF+** files), without normalizing them, then there is **no XMP metadata** added to the PDF file. You can then use the task [Export PDF Info](#) to export the PDFs metadata to an XML file.



**Note:** A full specification of how Esko uses XMP is available as part of the [Automation Engine Online Help](#), Find this document in the section below named "Related Documentation".

Because XMP is actually XML embedded in a file, you can also use SmartNames to query that metadata. **XMP path Query** SmartNames are very similar to **XPath Query** SmartNames. The main difference is that the source file is not a XML but a file with embedded XMP. The way to that metadata is also an **XPath Expression**.



**Tip:** When using an XMP XPath SmartName in the **Output** field of a this task ticket, and the XMP XPath cannot be resolved (because there is an error in the SmartName or the queried data cannot be found), the output file is saved in a `/xmp_unresolved` subfolder.

### 9.7.1. Creating an XMP XPath Query SmartName

When creating an **XMP XPath Query SmartName**, it is typical is that we first need to indicate our example input file, the one that contains the example XMP.

To create an **XMP XPath Query SmartName**, follow these steps:

1. In **SmartNames View**, in **Resolve all using**, check **A file** and browse to your (example) file that has the XMP metadata.
2. In **SmartNames View**, click on **[ ]\***.
3. Choose the **Type 'XMP XPath Query'**.
4. Choose a **Scope**. If you are not sure, choose **Global**. Learn more about [SmartName Scopes](#) on page 648.
5. The large canvas is where you define your **XPath Expression**. Initially, there is an example expression about `'vsize'`. If `'vsize'` is mentioned in the XMP of the input file you selected, it will already return a **Result** value (below left). This example expression will be removed automatically when you have used the **Edit** button and created your own. In this canvas, you can
  - type an XPath Expression (if you know how to do this).
  - click on **Edit** to open the **XPath Builder** and create your expression there. Learn more in [The XPath Builder](#) on page 678.
  - click on **Insert SmartName** to insert SmartName(s) into your **XPath Expression**. This is in most cases not needed.
  - right-click and choose an option: **Cut**, **Copy**, **Paste**, **Clear Contents** or **Insert SmartName**.
6. **Separator:** If the **XPath Expression** returns multiple elements, decide what character you want to use as separator.
7. **Result:** See the result of your **XPath Expression**.
8. **Formatting Options:** Learn more in [Formatting SmartNames](#) on page 696.

9. Click **Save** to save your SmartName and close the dialog. Click **Save As...** to save your SmartName but keep the dialog open (to create more SmartNames).

## 9.7.2. Examples

### Remember the many System SmartNames on 'Size'

There are many SmartNames that you no longer need to create yourself via XMP queries. Remember these default (system type) SmartNames with **Scope Page Information** that may already deliver exactly what you were looking for:

Name	Description	Type	Scope ^
Folios	A range of page names (folios) containing prefixes and suff...	System	Page Information
Layer Name	The name(s) of the layer(s)	System	Page Information
Layer Number	The number(s) of the layer(s)	System	Page Information
Number of Pages (RunList)	Number of pages in the RunList	System	Page Information
Page Height	Vertical trim size of the page	System	Page Information
Page Numbers	A range of page numbers (numbers are going from 1, for e...	System	Page Information
Page Width	Horizontal trim size of the page	System	Page Information
RunList Name	Name of the RunList	System	Page Information
RunList Number	Number of the RunList in the imposition	System	Page Information
Variant Name	The name(s) of the variant(s)	System	Page Information
Variant Number	The number(s) of the variant(s)	System	Page Information

Learn more about them in [Default System SmartNames](#) on page 661.

### What if my file does not have the XMP information I'm looking for?

For example: you want to get the 'size' of a native PDF. Your workflow does not create a normalized PDF version of it (where you would automatically get that extra XMP). In that case, you can use the **LinkEdge** task to create an XML containing the same XMP as you would find inside a normalized file.

The next step is then to use an **XPath Query SmartName** to get that specific XMP information from inside that XML file. Learn more on how to do this in [XPath Query SmartNames](#) on page 676.

### Which application created this file?

Most files with metadata will have a note about which application created the file. Follow these steps:

1. Follow the generic steps as explained in [Creating an XMP XPath Query SmartName](#) on page 683.
2. In the example XML, use CTRL-F or CMD-F to find for the string 'CreatorTool'.
3. Select the node. For example: see how the 'CreatorTool' is selected in the example below:

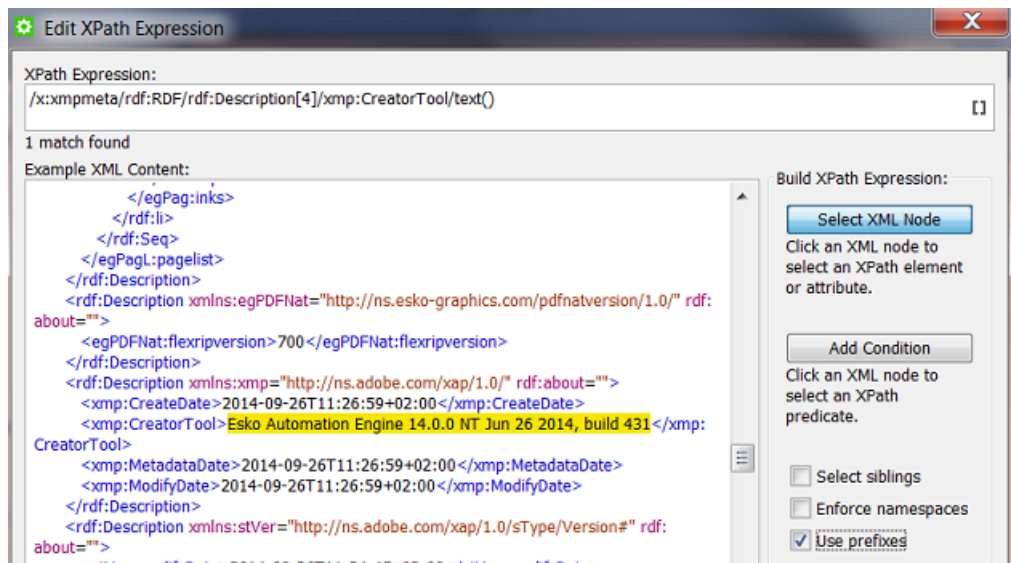

4. Click **OK**.
5. Check the **Result** and **Save** your SmartName.
6. Tip: to shorten this name, create another *String Extract SmartName* or a *Regular Expression*.

**Which options were used when RIP'ing this file?**

It can be useful to see with what resolution or distortion your RIP file was made. There are tools to quickly detect that in Automation Engine, but your remote print site may not have those tools. It can therefore be useful to extract that value and use it in a file name or (FTP) folder name.

Follow the similar steps as in above example. See the screen shot to detect even more RIP options in the XMP of a LEN file (made with **FlexRip** or **Imaging Engine**).

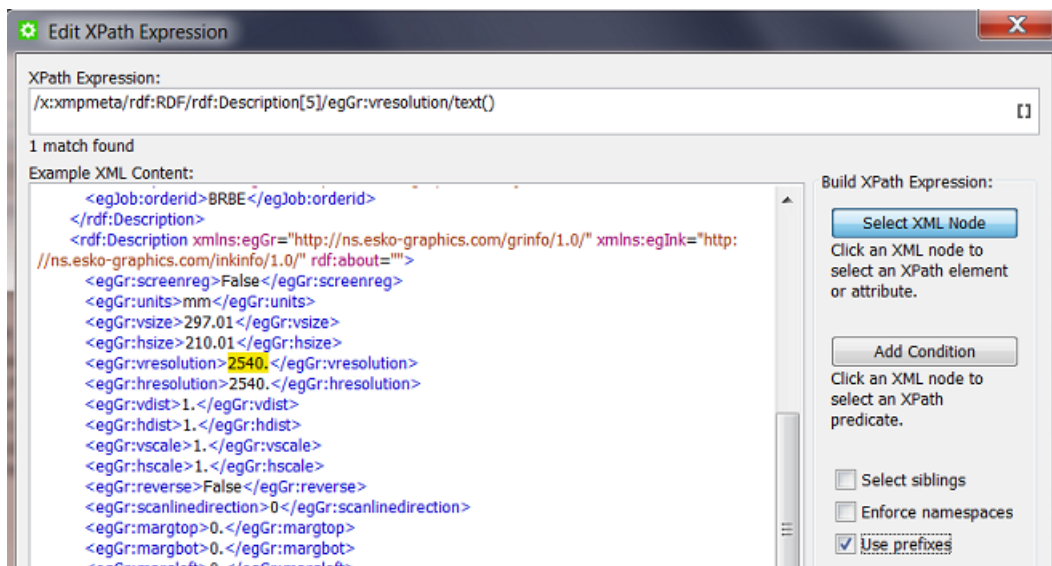

## 9.8. Conditional SmartNames

---

**Conditional SmartNames** base their value on one or more conditions. The condition can be very basic or can be built up of several criteria and sub criteria. You can also define the **order** in which the conditions need to be met.

After documenting how to create a **Conditional SmartName**, we illustrate their power with some examples.

### 9.8.1. Creating a Conditional SmartName (generic)

To create a **Conditional SmartName**, follow these steps:

1. In **SmartNames View**, click on .
2. Choose the **Type 'Conditional'**.
3. Choose a **Scope**. If you are not sure, choose **Global**. Learn more in [SmartName Scopes](#) on page 648.
4. The dialog initially contains 2 blocks.
  - A "**conditional block**". Each conditional block has one or more criteria and ends with the **Return** value for that block.
    - You can create extra conditional blocks using the buttons **Add / Remove** (Windows) or **+ -** (Mac).
    - You can also right-click in the line **If xxx of the following are true:** and **Duplicate** that block. Use the functions **Move Up / Down** or **drag and drop** the blocks to define their order.
    - The order of the blocks is the order that they will be checked, **from top to bottom**.

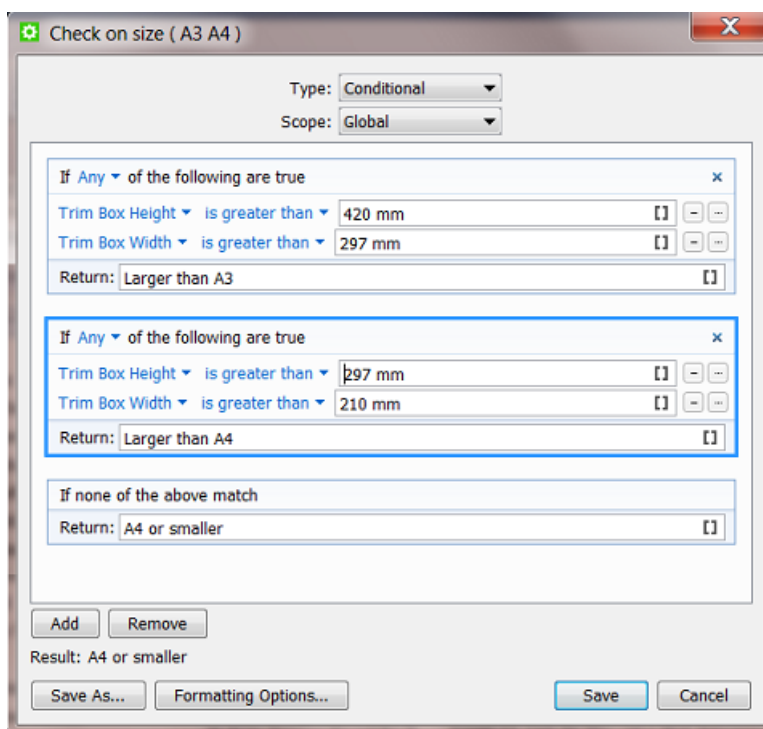

- Learn more details in [Setting up a Conditional Block](#) on page 687.
  - An "**alternative block**". When none of the above conditions match, this is what the SmartName's return value will be. Type in the value (or use another SmartName).
5. Check the result in **Result**.
  6. If needed, set any **Formatting Options**. Learn more in [Formatting SmartNames](#) on page 696.
  7. Click **Save** to save your SmartName and close the dialog. Click **Save As...** to save your SmartName but keep the dialog open (to create more SmartNames).

## 9.8.2. Setting up a Conditional Block

To set up a conditional block, follow these steps:

- **If All - Any - None of the following are true.** Choose the relation between the condition and your (one or more) criteria.
- Per criterion, you need to
  - select the attribute from the drop-down. Choose between the SmartName **File** or any **Other** SmartName.
  - select the text or number expression from the drop-down list. You can choose any of the following expressions from the drop-down, depending on whether it is a text or numeric condition:

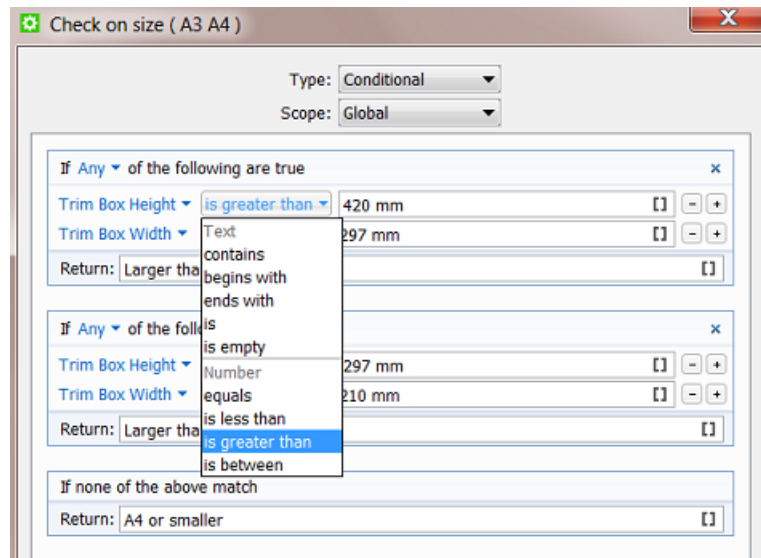

- For a **text** criterion, choose from the following expressions:
  - **Contains, begins with, ends with, is** and **is empty**.

Use ' ' (space) for 'AND' and ';' for 'OR'. For example, a text criterion specifying:

  - "'Inkname' **contains** 'Pantone C'": this will resolve all ink names that contain 'Pantone' *and* all that contain 'C'.
  - "'Inkname' **is** 'C; M; Y; K; '": this will resolve the ink names that are specifically *any of these*.
  - Use double quotes to specify the exact text corresponding to the attribute. For example: "Inkname **contains** "reflex blue" ": this will *only* resolve for "reflex blue".
- For a **number** criterion, choose from the following expressions: **equals, is greater than, is less than**, and **is between**. Some important notes:
  - If the attribute does not correspond to a number, it will be ignored.
  - You can use standard unit symbols and unit conversions are done in background. For example: if you specify "**equals** 5 mm" then this is not a problem when the file's XMP is defined in in (inches).

 **Note:** Unit conversions only work with units of the same kind. For example if the specification is "**equals** 5 mm" then this will fail to resolve when the XMP mentions "6 ppi" or just "6".

 **Note:** Number expressions will not resolve to text strings. For example: "**Job Name equals** MyJobName " will be ignored because **equals** is used for numbers, not text.



**Note:** Quotes ( " ) and semicolons ( ; ) are not accepted as values in the text and number conditions.

- Adding criteria: You can add a criterion to a condition by clicking the +.
- Adding **sub criteria**. When you hold **Alt** while clicking the +, your new criterion will be a sub-criteria of the one above. See [Examples](#) on page 689 where we use it to exclude some attributes that were selected in the one above.

### 9.8.3. Examples

#### Plate distortion depending on cylinder size

A **Job Category** is used to define size of the cylinder on which the product will be printed. This circumference has an effect on the distortion that is required for the plate. A **Conditional SmartName** defines the distortion setting for the RIP.

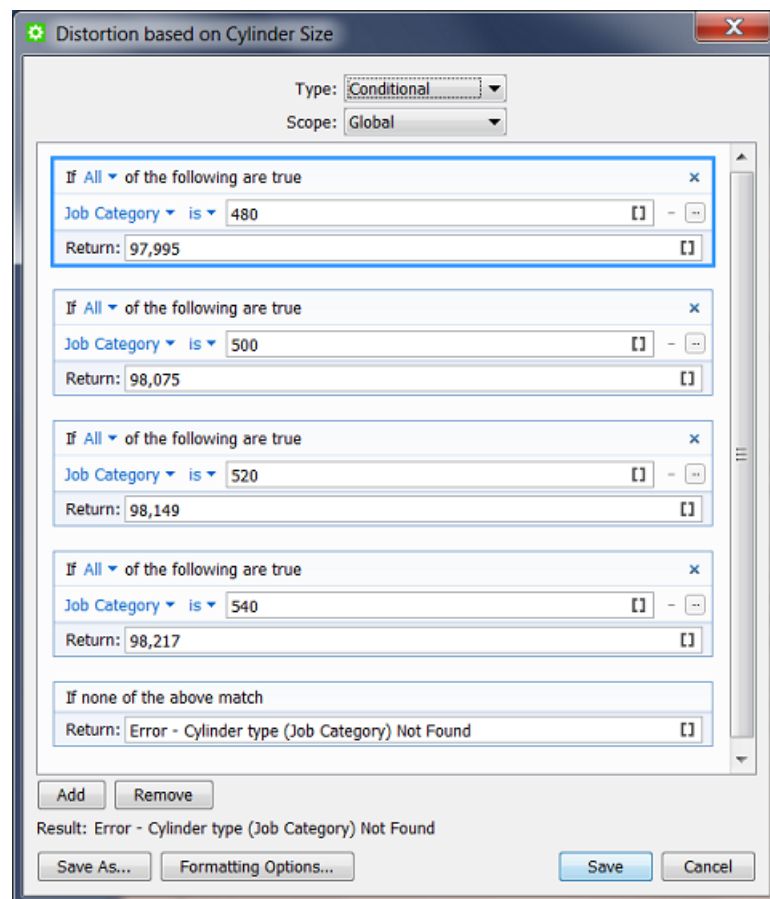

#### ReportMaker Template depends on the Customer

The ReportMaker ticket uses a SmartName to select its template. A conditional SmartName checks who the customer is.

- First we check if it is our biggest customer 'FruitCo' (ID 777).
- Then we check if it is any customer of the group 'SuperToy' (any of those 3 IDs).
- If it is none of the above, we use a generic template for all other customers:

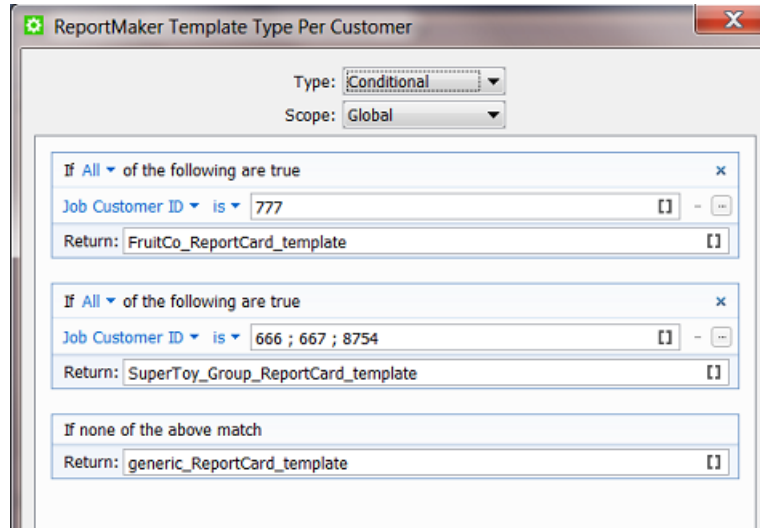

**Dot Gain Compensation depending on the Press and type of flexo plates**

If the press chosen for the Job is the flexo press Nilpeter, then the DGC file depends on the category where the type of plates is defined: conventional flexo plates or digital flexo plates (CDI):

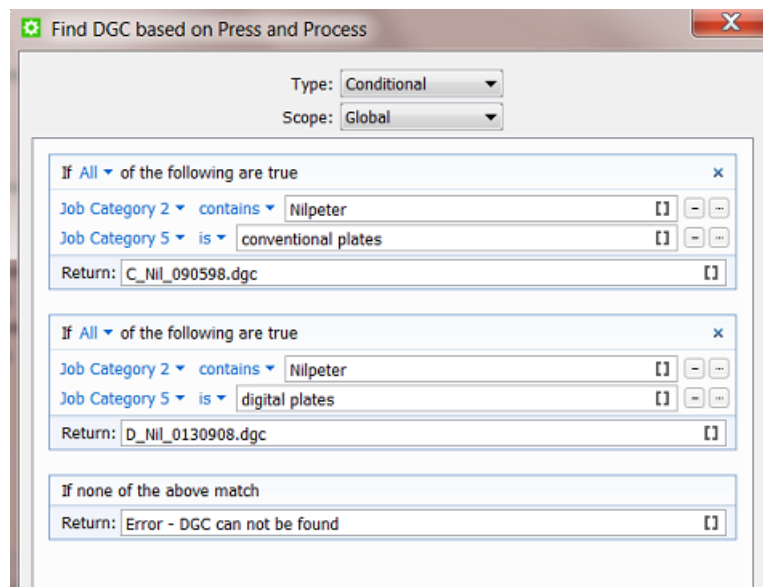

**Find the French only version (using a sub criterion to exclude some attributes)**

Our SmartName is looking for Jobs that are in the French language, but not in combined language versions. See how the extra sub criterion (ALT-+) excludes the categories that contain the Canadian and Belgian version Jobs that combine French with another language:



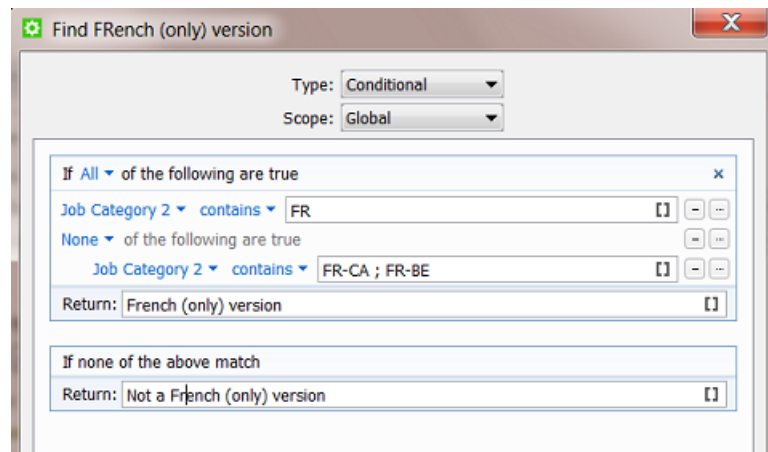

**Smart preflight checking a workflow parameter 'Print Process' to check allowed line width**

Our workflow includes **PitStop** preflight. It is **Smart Preflight** because it uses SmartNames. Our example shows how the **preflight profile** will check line width but have it depend on the print process that the file will be printed in. The print process is defined as a workflow parameter.

- This is our workflow parameter: [wfp.Print Process]

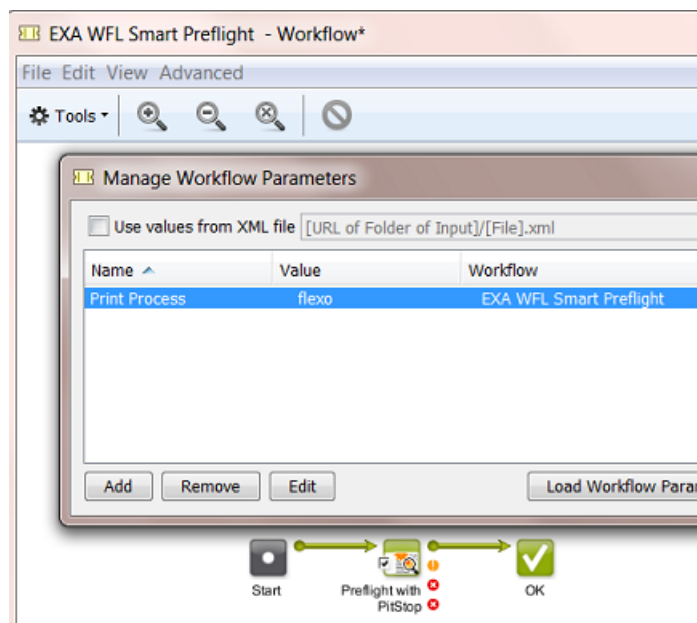

- This is how we set up our conditional SmartName (3 print processes each get a condition on line width (mm)):

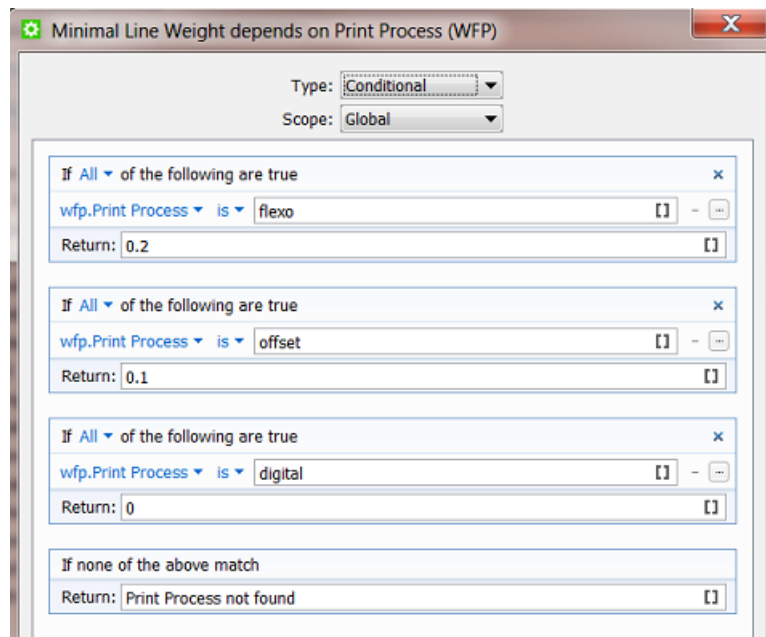

- This is how our SmartName is used inside the PitStop Profile (there named 'variable'):

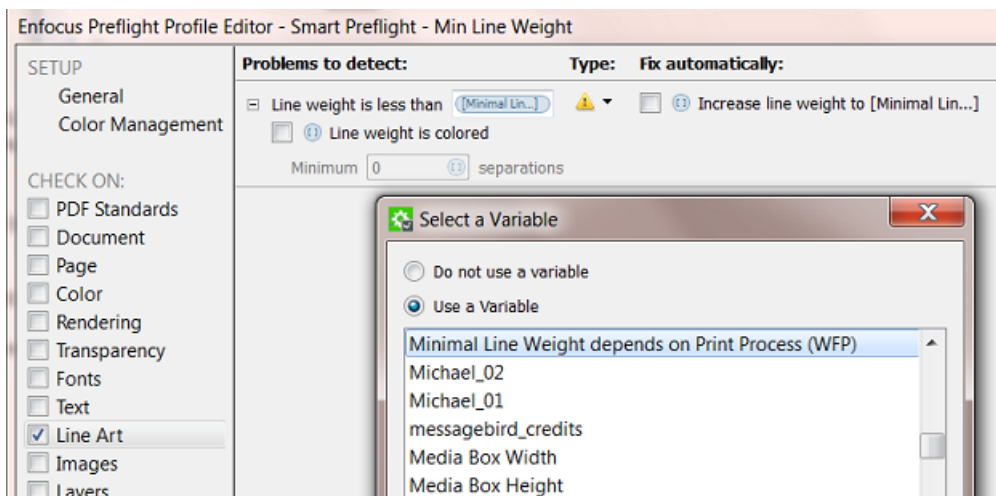

## 9.9. Database Query SmartNames

### 9.9.1. Concept

**Database Query SmartNames** ask a question to an external database (a DB outside of AE). They pick up information from other systems, typically business systems (planning, production ...). They only ask information, they do not write information into that external system.



**Note: Database Query SmartNames** may not be used to pick up information from a database from Automation Engine itself. For such use cases, you use the **System (Value) SmartNames**. Learn more in [System \(Value\) SmartNames](#) on page 661.



**Restriction:** In an [AE SaaS](#) setup, you can not use Database Query SmartNames.

**Some typical examples when you use Database Query SmartNames:**

- In the **Tabular Step & Repeat** task. You can fill its many fields with **Database Query SmartNames** and so pick up all the required values. Narrow-web label printers often use this and base their queries on press type and die-shape.
- As a RIP option that you pick up from an external system. For example your business system that created your Job may have informed you about main production decisions like the press, the amount of plates and their size. But the distortion factor may need to be picked up from another external system closer to the press room. In that case, you use a **Database Query SmartName** in your RIP's setting for distortion.

**How do Database Query SmartNames compare to the other tools that access databases?**

- A **Database Access Point** also does a database query but its other main feature is that it triggers a workflow, and maybe you do not want that to happen at the moment you pick the information.
- The **Interact with Database** task can read *and* write into external databases and can be used as any step of a workflow. But it does not return you the values immediately, you get them in a separate XML file from where you need to pick them up again (then via **Xpath Query SmartNames**).



**Note:** In cases where that XML is *already* available, it is advised to use the information from the XML. For example: the XML that was used to create the Job, is stored in the Job Folder and it also contains all the Step & Repeat information. In that case it is advised to pick up that Step & Repeat info locally instead of asking it again to an external system (which always means network traffic and small delays).

Basically, **Database Query SmartNames** is the preferred tool when you *only* want to pick up a value and when an extra return-XML has no added value.

## 9.9.2. Creating a Database Query SmartName

**First set up the link to that external database**

Setting up a link to an external database is done in **Tools > Configure > External Databases**. Learn more on this in [Configuring links to External Databases](#).

**Now create the Database Query SmartName**

To create a **Database Query SmartName**, follow these steps:

1. In **SmartNames View**, click on .
2. Choose the **Type 'Database Query'**.



**Warning:** From AE 22.07 on, (32-bit) ODBC query SmartNames are set to be **'Soon Outdated'**. Learn more in [Concept of \(Soon\) Outdated Tasks / Features](#) on page 531.

3. Choose a **Scope**. If you are not sure, choose **Global**. Learn more in [SmartName Scopes](#) on page 648.
4. Choose the **External Database** from the drop-down list. If you need to create, change or test the link to an external database, click **Configure**.
5. Write your **SQL Command** in the canvas. You can **Insert SmartNames** into your command.



**Note:** Esko does not provide training in SQL commands. Contact your own IT database specialist to help set these up.

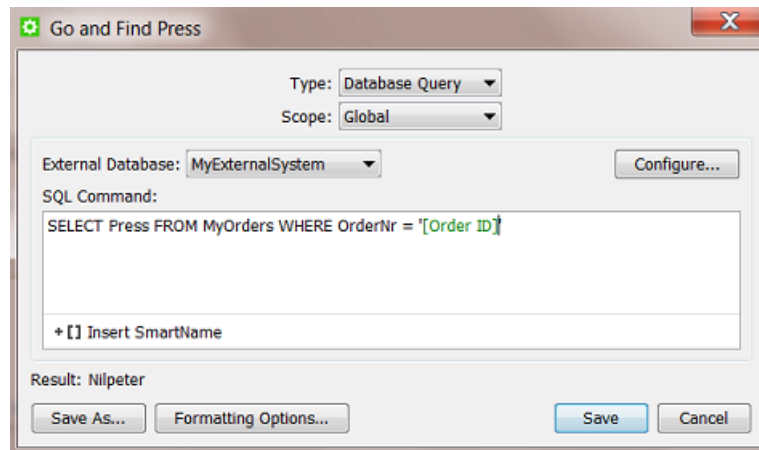

6. Check the **Result**. The result will be (re-)calculated when you click any option outside the canvas.
7. If needed, set any **Formatting Options**. Learn more in [Formatting SmartNames](#) on page 696.
8. Click **Save** to save your SmartName and close the dialog. Click **Save As...** to save your SmartName but keep the dialog open (to create more SmartNames).

### Learn more about integrating with external databases

Learn more about using SQL commands in the chapter [Integrating with External Systems](#) on page 1769, in the sections

- [Database Access Point](#) on page 1791
- [Task 'Interact with Database'](#) on page 1843
- [An elaborate example](#).

## 9.10. Script SmartNames

**Script SmartNames** use **JavaScript** to get a value. Typically, other SmartNames are inserted into the script.

**JavaScript** is a standard scripting language. Learn more on [http://en.wikipedia.org/wiki/JavaScript\\_syntax](http://en.wikipedia.org/wiki/JavaScript_syntax) or on [http://www.w3schools.com/js/js\\_syntax.asp](http://www.w3schools.com/js/js_syntax.asp).



**Attention:** Before you create a **Script SmartName**, check if it can be built using standard tools as

- a **Conditional SmartName**
- a **Regular Expression** (in a **String Extract SmartName**).

### 9.10.1. Creating a Script SmartName

To create a **Script SmartName**, follow these steps:

1. In **SmartNames View**, click on **[ ]<sup>+</sup>**.
2. Choose the **Type 'Script'**.
3. Choose a **Scope**. If you are not sure, choose **Global**. Learn more in [SmartName Scopes](#) on page 648.
4. The canvas initially shows a JavaScript template that returns the value "hello".



**Attention:** This template is important. The script needs to be a function returning a value that is called from the body of the script. Learn more in this [Esko KB article](#).

Replace it with your own JavaScript. You will probably **Insert SmartNames** into your script. See some examples in [Examples](#) on page 695.

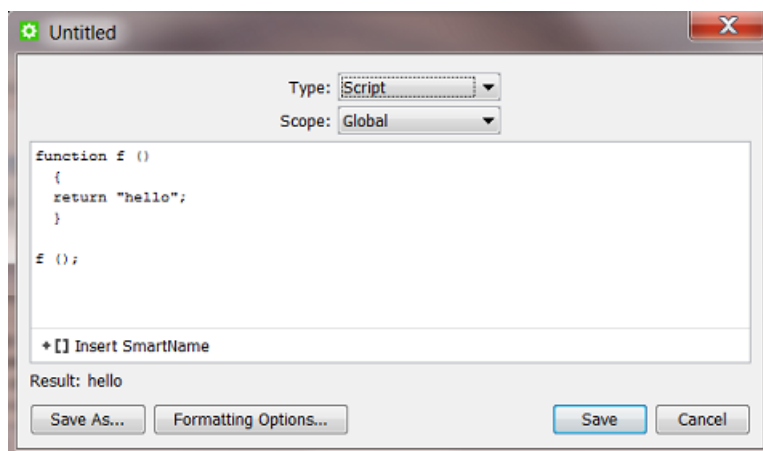

5. Check the result in **Result**. The result will be (re-)calculated when you click any option outside the canvas.
6. If needed, set any **Formatting Options**. Learn more in [Formatting SmartNames](#) on page 696.
7. Click **Save** to save your SmartName and close the dialog. Click **Save As...** to save your SmartName but keep the dialog open (to create more SmartNames).

### 9.10.2. Examples

The following examples are just a few basic samples of what a JavaScript can do. If you need help, Esko has specialists available through [Esko Solution Services](#) (Not the regular Esko Support).

### Calculating: Multiply

This JavaScript multiplies the values of 3 **Job Parameters** (number SmartNames):

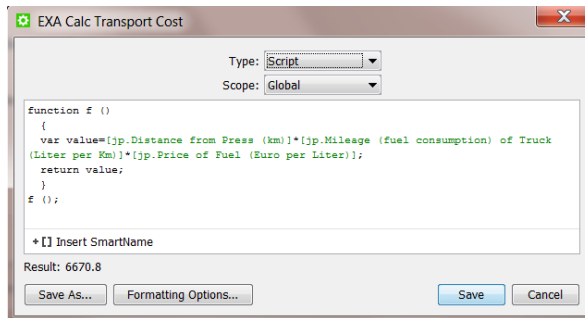

### Extracting a few lines from a text:

This JavaScript returns the first 2 lines of a SmartName, in this case the **Job Description**:

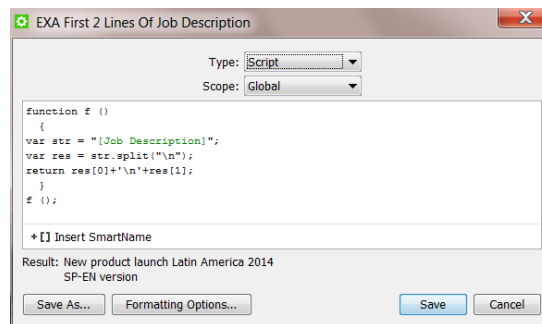

## 9.11. Formatting SmartNames

A lot of data that end up in SmartNames can come from external systems. And a lot of information that you send back out to external systems may also be decided by SmartNames. These systems can store their information in a different language, in a different regional format or even a specific custom format. That is why it may be needed to change the format of a SmartName.

The formatting options are different whether your data is a **Text**, a **Number** or a **Date or Time**.



**Note:** A data string that contains both numbers *and* text characters is seen as **Text**. For example: 789\_87\_banana is **Text**.

The option **Formatting Options...** is available when you create any SmartName.

### 9.11.1. Text Formatting

When, in **Formatting Options...**, you select the **Data Format 'Text'**, you get the following options:

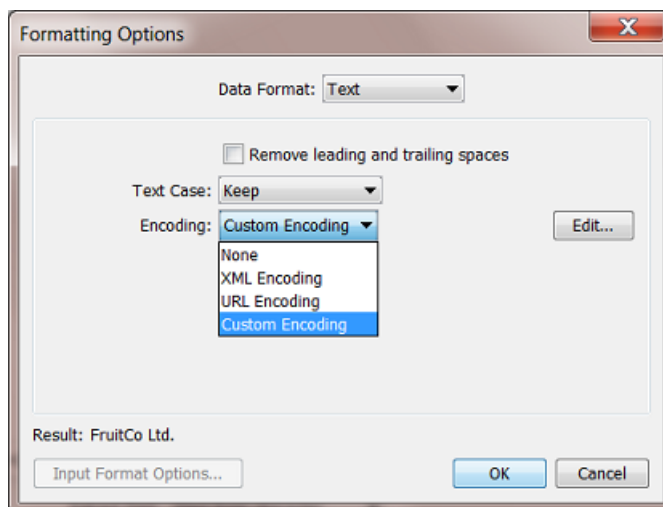

- **Remove leading and trailing spaces:** If your SmartName value includes space characters at the beginning or end, use this option to remove those spaces.
- **Text Case:**
  - **Keep** the original case of the SmartName value.
  - change the text case using **Make Upper Case** or **Make Lower Case**.
- Specify any special **Encoding** of the SmartName value. Choose
  - **None** to leave it like it is.
  - **XML Encoding.** If your SmartName output will be used inside an XML file, your value can contain a character that has a special meaning in XML (a 'reserved character'), then this encoding will replace that character by a by an XML entity reference. For example '10<20' will be formatted to '10&lt;20'.
  - **URL Encoding.** Similar to the above, this will replace the reserved characters for URLs with the typical 'percent encoding'. For example 'Digital Flexo' will be formatted to 'Digital%20Flexo'.
  - **Custom Encoding:** Use it to define custom replacements of characters or strings. Click **Edit** and add one or more lines of rules. The rules will be executed from top to bottom. For example:

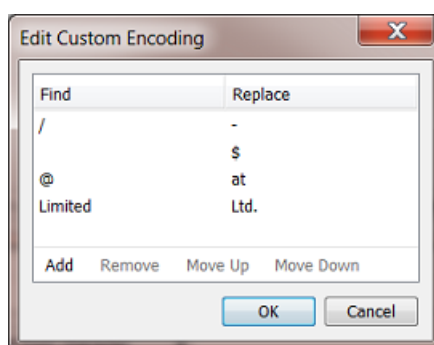

- First all '/' will be replaced by a '-' (needed when you use this text to become a Windows-supported path)
- then all ' ' (spaces) will be replaced by a Dollar sign
- then all '@' will be replaced by 'at'
- then all words 'Limited' will be replaced by 'Ltd.'

The **Result** will update after a new setting as soon as you click in a different field.

### 9.11.2. Number Formatting

When, in **Formatting Options...**, you select the **Data Format 'Number'**, you get the following options:

#### First check or define the Input Format Options.

Why first? Because this might already have an effect on the **Result** that you will be checking when you start the actual (output) formatting options.

The **Input Format Options** allow you to inform Automation Engine how your input is constructed, how it should be interpreted.

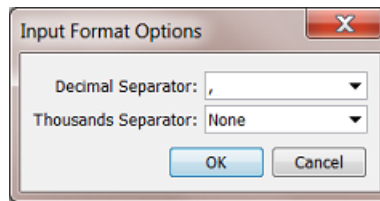

For example: Your input is '123456,789' and you want to indicate now that your **Decimal Separator** is the ',' (comma) and that there is no **Thousands Separator (None)**. You will already see a change in the **Result**.

#### (Output) Formatting Options

Now define how you want this **Result** formatted.



**Note:** If the **Result** is *already* what you want, this means that the default settings in the **Formatting Options** panel may already be the ones you want.



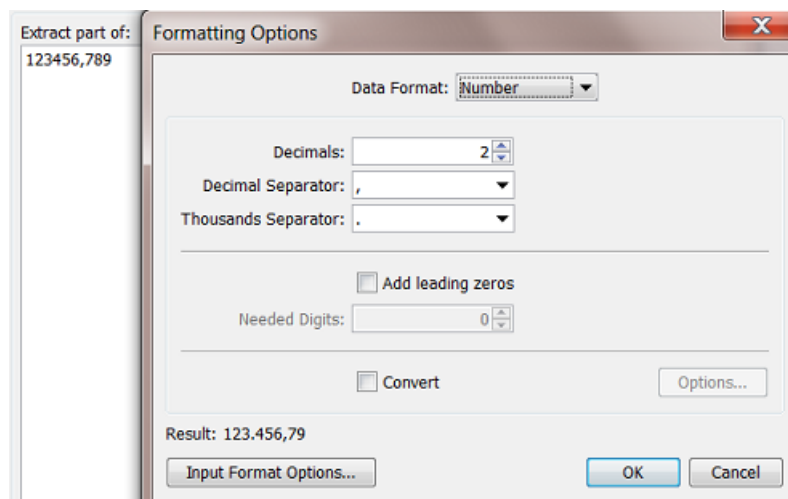

- **Decimals:** Indicate how many decimals you want. Select **Auto** to keep the number of decimals like it was in the original value of the SmartName. See in above screen shot how the setting 'decimals: 2' takes one decimal away and rounds the number to '79'. Another example is to round values with too detailed numbers like '67,5000000000' to shorter ones like '67,5' (one decimal left).
- **Decimal Separator:** Select the type you want. In above screen shot we confirm that the comma is the one we want (to keep).
- **Thousands Separator:** Select the type you want. See in above screen shot how it adds the point in between '3' and '4'.



**Note:** The decimal and thousands separators cannot be identical.

- You can choose to **Add leading zeros** to the value of the SmartName to get a certain number of **Needed Digits**. If the value of the SmartName has less digits in the integer part than the specified number of needed digits, leading zeros will be added until the number of needed digits is reached. For example, if the number of needed digits is 5, "123" becomes "00123".
- You can choose to **Convert** the value of the SmartName to another unit.
  - **Length.** Choose, in both directions, from **Millimeters, Centimeters, Decimeters, Meters, Inches, Mils** and **Points**
  - **Angle.** Choose, in both directions, from **Radians** and **Degrees**.
  - **File Size.** Choose, in both directions, from **Bytes, Kilobytes, Megabytes, Gigabytes** and **Terabytes**.
  - **Resolution.** Choose, in both directions, from **Pixels per Inch, Pixels per Millimeter, Pixels per Centimeter, Lines per Inch, Lines per Millimeter** and **Lines per Centimeter**.
  - **Time.** Choose, in both directions, from **Milliseconds, Seconds, Minutes, Hours, Days** and **Weeks**.

### 9.11.3. Date and Time Formatting

When, in **Formatting Options...**, you select the **Data Format 'Date and Time'**.

It is very important that you **first** check or define the **Input Format Options...**

## Input Format Options

**Date and Time** descriptions appear in many different formats. Before a SmartName value can be reformatted, it will be required to first explain Automation Engine how your input value is constructed. This is what you do in **Input Format Options**.

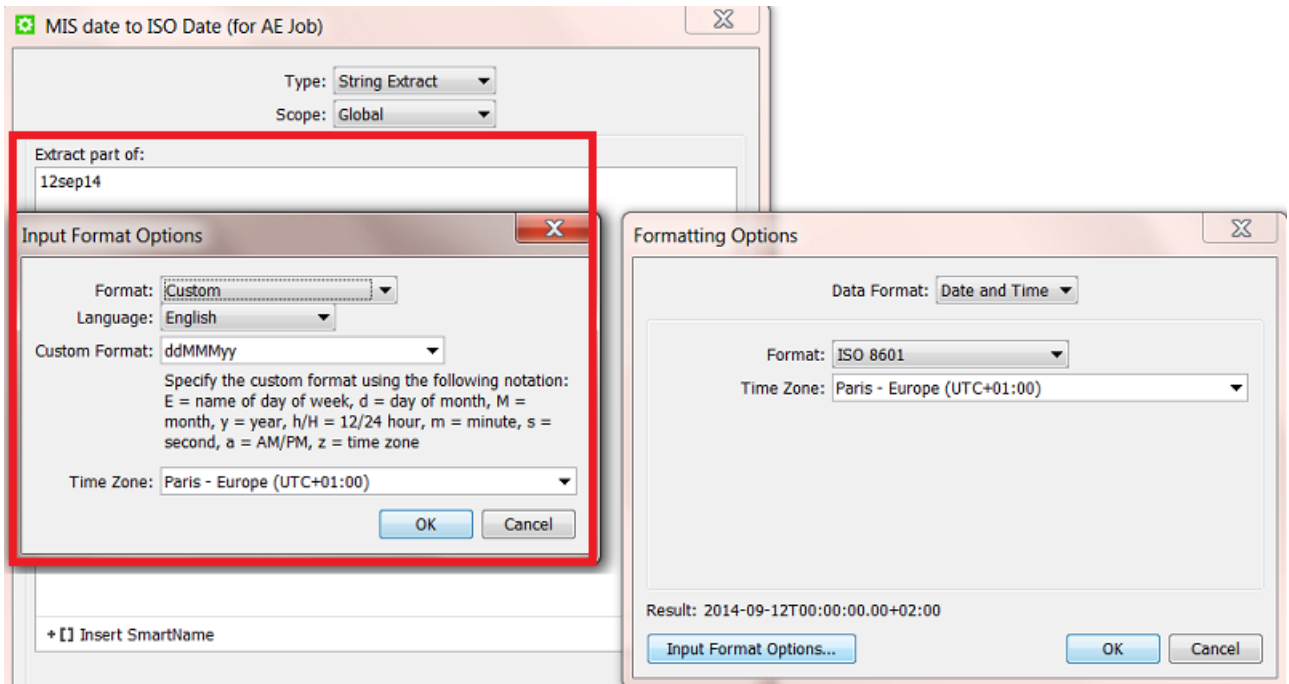

### Format: ISO 8601

Select this when your input date and time is in this standard format. This will be the case when the date was constructed by Automation Engine. For example: your input data is '2014-09-27T16:30:00.00+02:00' (September 27 2014, 4:30 PM in the time zone UTC+2).

### Format: Unix Time (in milliseconds)

Select this when your input date and time is in this standard format. Unix time is used widely between computers, it is the amount of seconds that have passed since 1 January 1970. For example: '1410532200000' (milliseconds).

### Format: Custom

Select this when your input date and time is in any other format than the 2 above mentioned standards.

- **Language:** the language that you select here affects the list of default custom date and time formats in the **Custom Format** drop-down list.
- **Custom Format:** indicate here how your custom input is constructed. You can specify the custom format using the following notation: E = name of day of week, d = day of month, M = month, y = year, h/H = 12/24 hour, m = minute, s = second, a = AM/PM, z = time zone. Learn more in this [Example](#) on page 701.

- **Time Zone:** If you want, you can select the **Time Zone** of the original value of the SmartName.

### Output Formatting Options

Once your input format is well understood by Automation Engine, you define the output **Formatting Options**.

You here have the same options as in [Input Format Options](#) on page 700.



**Note:** If your **Date and Time** serves a field in any Automation Engine database, it needs to be formatted according **ISO 8601**.

### Example

You have a workflow where your MIS sends you an XML every time a new Job has to be created on Automation Engine (see an example of such workflows in [Examples of integrating with an external system](#)).

The XML from the MIS mentions the Job's **Due Date** but has its own particular way of mentioning the date and time. We will need to reformat it to the standard **ISO 8601** (that Automation Engine requires in this example).

Follow these steps to get the result as shown in the screen shot:

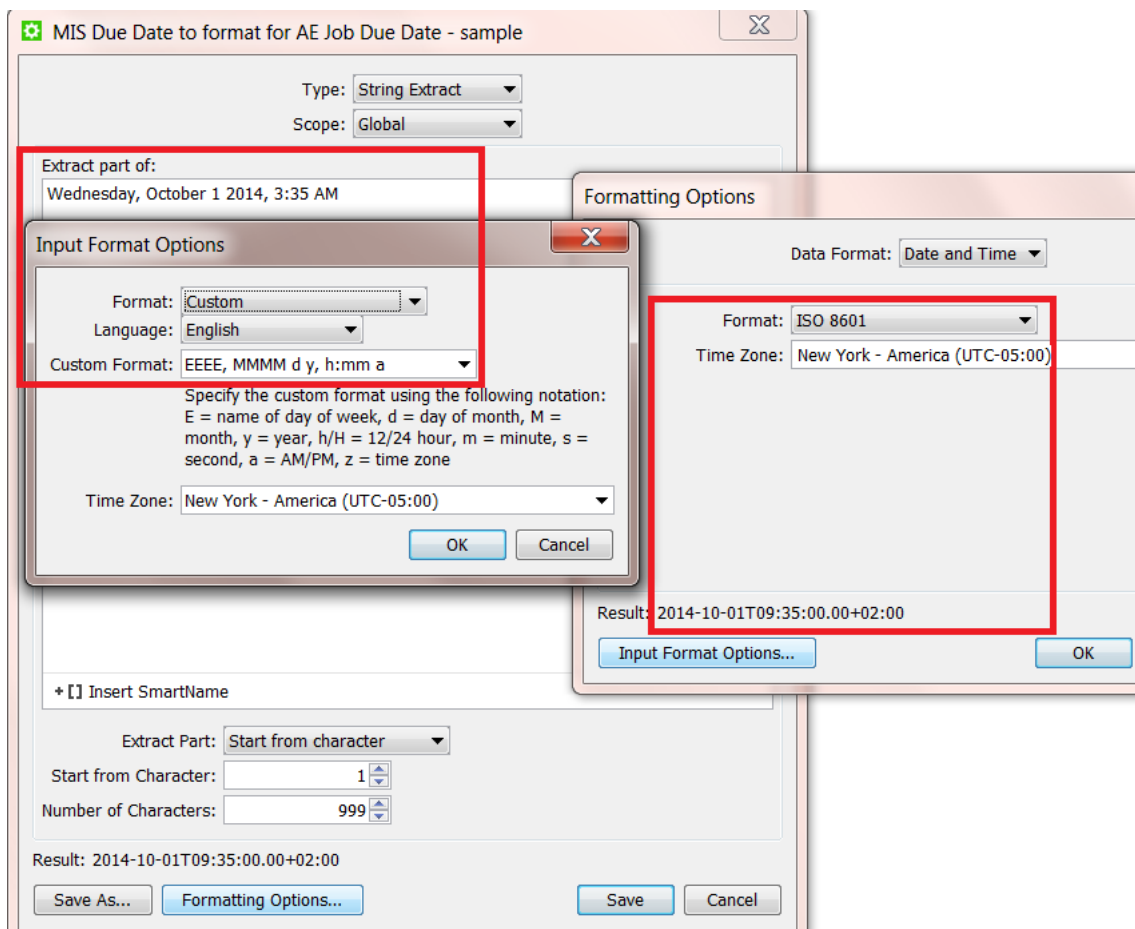

- In the setup of the SmartName, you see our input value 'Wednesday, October 1 2014, 3:35 AM'. Normally this date would in this canvas not be written out like this but it would show up as another SmartName, one that picks up that date from the XML that we mentioned earlier.
- Click **Formatting Options...**, do not check or change any settings there yet.
- Click **Input Format Options...**, Choose **Custom** and **English**.
- In **Custom Format**, type the string that you see in the screen shot. This is what those codes mean:
  - 'EEEE': 'E' means 'day of the week'. 4 times 'E' means the day is written out in full text.
  - then there is a comma and a space
  - 'MMMM': 'M' means 'month'. 4 times 'M' means the month written out in full (text).
  - then a space followed by 'd', meaning the day of the month (number)
  - then a space followed by 'y', meaning the year, in (full) number
  - then again a comma and a space
  - then 'h:mm', meaning the hour (in 12 hour system), followed by a colon, followed by the minutes
  - then a space and 'a', meaning 'AM'.
- Indicate that this time is one from the `New York` time zone.
- Click **OK** to confirm and close the **Input Format Options** dialog.
- Now set the (output) **Formatting Options**: Choose the **ISO 8601 format** and choose the same `New York` time zone
- Check the **Result**: you should see a ISO 8601 format of the custom description that we received.
- **Save** the SmartName with a logical name.
- This SmartName (date) is one that we can now use in the **Create Job** task, for the **Job Due date**.

## 9.12. Using Regular Expressions

---

**Regular Expressions** are text patterns that are used to match strings. They can contain a mix of plain text and special characters to indicate what to match. Find more information about this standard tool on [Wikipedia](#).

In Automation Engine, they are used for special cases where SmartNames do not offer a solution. You can use **Regular Expressions** in

- **String Extract SmartNames**
- Some tasks: **Select File**, **Select Marked File**, **Wait for Files**, **Download from EskoCloud ...**
- Some **Workflow Controls**: **Data Splitter**, **Sort** and **Router** (when using 'matches' or 'does not match').
- In **Configure > Smart Job Location** (when setting up a rule, in the field 'Matches'. )



**Note:** Above tools also offer the [RegEx Builder](#), a tool that helps you build the expression.

### 9.12.1. A Selection of Useful Characters in Regular Expressions

Character	Description	Example
^	Beginning of the string. ^abc will only lead to a match if the string begins with abc.	^C matches "Cyan" but doesn't match "PANTONE 120 C".
	OR	cat   dog matches "cat" or "dog"
\$	End of the string. xyz\$ will only lead to a match if the string ends with xyz.	120\$ matches "PANTONE 120" but doesn't match "PANTONE 120 C".
.	The . matches any single character.	ab . d matches "abcd" as well as "ab9d" or "ab-d".
[abc]	Brackets enclosing a set of characters indicates that any of the enclosed characters may match the target character.	[abc] matches "a", "b" or "c" but doesn't match "x" or "y".
[^abc]	The ^ inside the brackets means that none of the enclosed characters may match the target character.	[^abc] matches "x" or "y" but doesn't match "a", "b" or "c".
[a-zA-Z]	The - inside the brackets is used to show a range of characters.	[a-zA-Z] matches all upper and lowercase characters, [0-9] matches all digits.
\d	matches a numeric character (digit) (exactly the same as [0-9]).	\d\d matches "96" but doesn't match "5a".
\D	matches any non-numeric character (exactly the same as [^0-9]).	\D\D matches "A+" but doesn't match "A4".
\s	matches a whitespace.	\d\s matches "5 " but doesn't match "5a".
\S	matches any non-whitespace character.	\s\S matches " 6" but doesn't match "".
\w	matches an alphabetic (word) character (exactly the same as [a-zA-Z0-9]).	\w\w matches "9d" but doesn't match "5+".
\W	matches any non-alphabetic character (exactly the same as [^a-zA-Z0-9] or [^\w]).	\W\W matches "+" but doesn't match "5+".
?	The ? matches the character to its left 0 or 1 times.	esk\w? matches "esk" as well as "esko" but doesn't match "eskonv".
*	The * matches the character to its left 0 or more times.	c* matches "", "c", "cccc" etcetera. esk \w* matches "esk" as well as "Esko".

Character	Description	Example
+	The + matches the character to its left 1 or more times.	c+ matches "c", "cccc" but not "". esk\w+ matches "esko" as well as "Esko" but doesn't match "esk".
{n}	The {n} matches the character to its left exactly n times.	a{3} matches "aaa" but doesn't match "aa" or "abc". ab{3}c matches only "abbbc".
{n,}	The {n,} matches the character to its left at least n times.	a{3,} matches "aaa" or "aaaaa" but doesn't match "aa" or "abc".
{n,m}	The {n,m} matches the character to its left at least n times, but no more than m times.	a{3,5} matches "aaa", "aaaa" or "aaaaa" but doesn't match "aa" or "aaaaaa".
\	Escapes characters with a special meaning. The \ can precede a special character (like * or [ ) if you want to search for it literally.	esko\\artwork\\*nv matches "esko \artwork*nv". \?\$ matches "?" at the end of a line.

**Some examples based on the above list**

Regular Expression	Matches	Doesn't Match
\d{6}-\w{5}-\d{1,3}\.pdf	312454-ESK04-1.pdf 235682-USA12-23.pdf	31245 <b>A</b> -ESK04-1.pdf 312456- <b>USA</b> -23.pdf
PANTONE \d+ C\$	PANTONE 120 C PANTONE 15 C	PANTONE 120 <b>U</b> PANTONE 15 <b>CU</b>
[Yy].*	Yes y	N no
(Cyan) (Magenta) (Yellow)	Cyan Yellow	Black Cyan SpotColor

### 9.12.2. Using Parentheses to Extract

**Use ( ) in the regular expression to define what to extract**

Parentheses are used to define what you want to extract (to "capture a group").

Example:

- Input string: lemon
- Regular expression: le (mo) n
- Output: mo

**What if I want to extract multiple groups?**

Automation Engine does not support this. Only the first group in the string between ( ) will be extracted.

Example:

- Input string: lemonandmango
- Regular expression: le (mo) na (nd) man (go)
- Output: mo

### What if the input string already contains ( ) ?

When the input string already contains a set of parentheses, you have to "escape" those characters, by adding a \ in front of them.

Example:

- Input string: ab (cd) e We want to extract the group between the ( ).
- Regular expression: .\* \ ( ( .\* ) \) .\*

In human language: *something, then an open parentheses, then the group we want to extract, until there's a closing parentheses, followed by something.*

- Output: cd

## 9.12.3. Examples from Users

These examples came from some customers. You may find more on [Esko's Knowledge Base](#).



**Note:** These examples were documented here before the [RegEx Builder](#) was introduced in v18.

### Extracting the last character of a string

The SmartNames function [Start From Character](#) on page 673 makes it easy to extract the *first* x characters of a string. With **Regular Expressions**, you can extract the *last* character(s). See this example (you can change the number to extract more (last) characters):

Example input string: banana

Regular expression: .\* (. {1})

Output: a

### Extracting the server name from the SmartName 'Operator'

Example input string: Chantal@AESERVER01

Regular expression: (.+)@.+

Output: Chantal

### Extracting the domain from an E-mail address

Example input string: michael.jackson@esko.com

Regular expression: `.+@(.+)\.[a-z]+`

Output: `esko`

### Extracting the part of a file name after the last underscore

Example input string: `Banana_v03_271265_p003.pdf`

- with the file extension
  - Regular expression: `.*_(.*)`
  - Output: `p003.pdf`
- without the file extension
  - Regular expression: `.*_(.*)\..*`
  - Output: `p003`

### Extracting the part of a file name between the 2nd and 3rd underscore

Example input string: `Banana_v03_271265_p003.pdf`

Regular expression: `[^_]*_[^_]*_(.*?)_.*`

Output: `271265`

### Extracting a number from a file name

Example input string: `Cosmo453_Advertisement_4.pdf`

Convention in human language: *something\_something\_number.pdf*

Regular expression: `.+_._+([0-9]+).pdf`

Output: `4`

### Defining a specific file selection - containing an 'exclude'

Some typical examples for use in the **Select File** task:

- To select all files except files where the name contains `_report` :

```
(?!.*_report).
```

- To select all files but exclude MAC files (starting with `.`) :

```
(?!\.).*
```

- To select all ArtPro files, but exclude the automatically generated backup file:

```
(?!.* BU).*\.ap
```

### Defining a specific file selection



- To select the file and the report of the file:

```
<file/>.pdf|<file/>_report.pdf
```

- To select only files with specific extensions. For example only the ARD and MFG files:

```
.*\.ard|.*\.mfg
```

### 9.12.4. The RegEx Builder

Much like the *XPath Builder* helps to build XPath commands, the **RegEx Builder** will help you create Regular Expressions.

To open the RegEx Builder:

- In an input field that allows many types of input data, click on **RegEx**.
- In an input field that only allows regular expressions only, click on **Edit**.
  - For example: When you create a SmartName of the type 'String Extract':

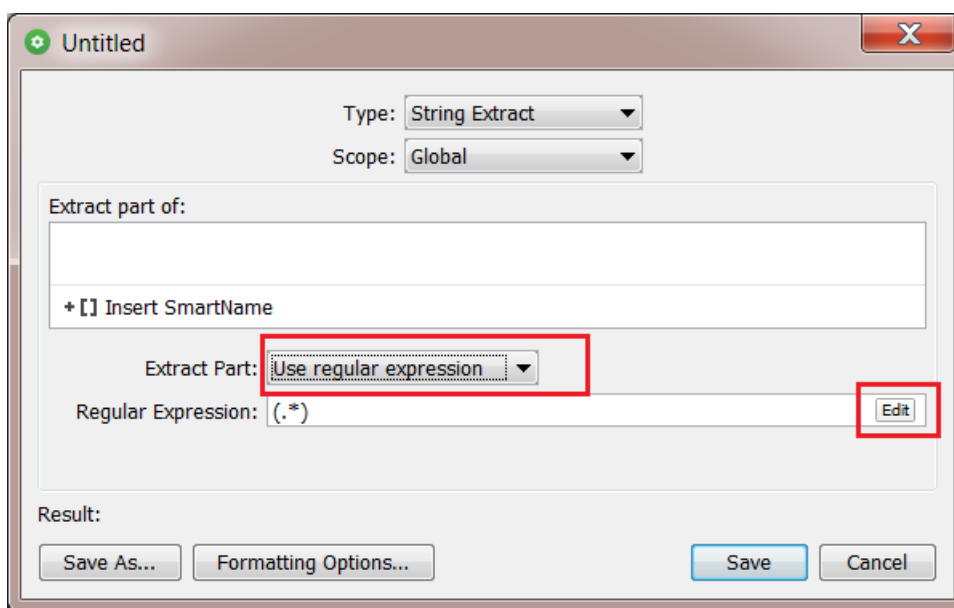

We will use examples to explain the functionality in this tool.



**Important:** Do check these examples in the below order. They explain different features, from basic to more advanced ones.

#### RegEx Example 1 - Extracting the Domain Name from an E-mail Address

1. Open the RegEx Builder. The top part shows a **'Pattern Editor'**.  
You can choose to hide it. However we will use it in these examples.

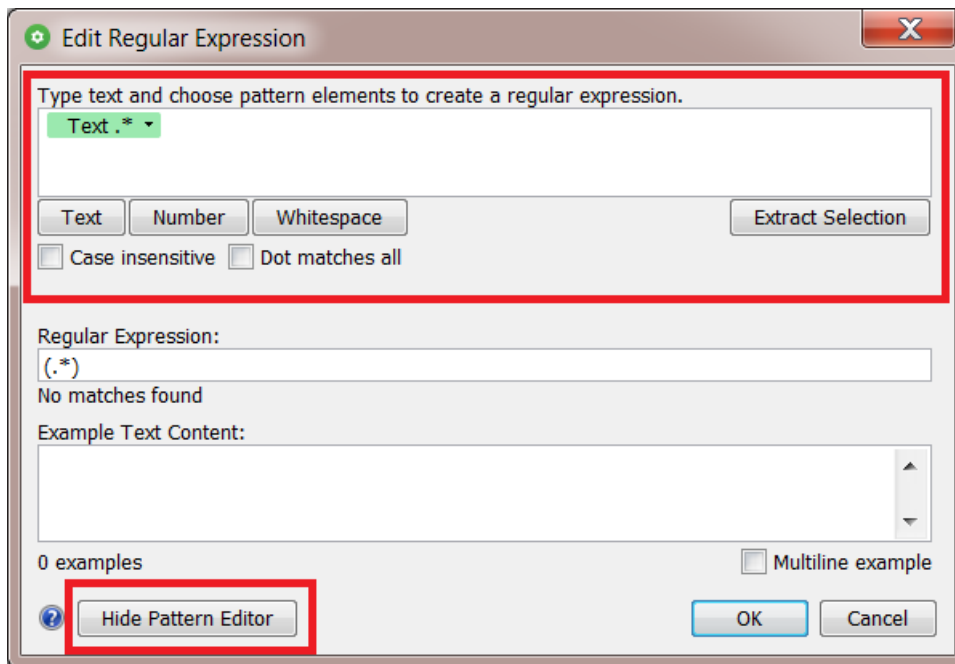

2. Add a text example in the field below. In our example, a typical E-mail address:

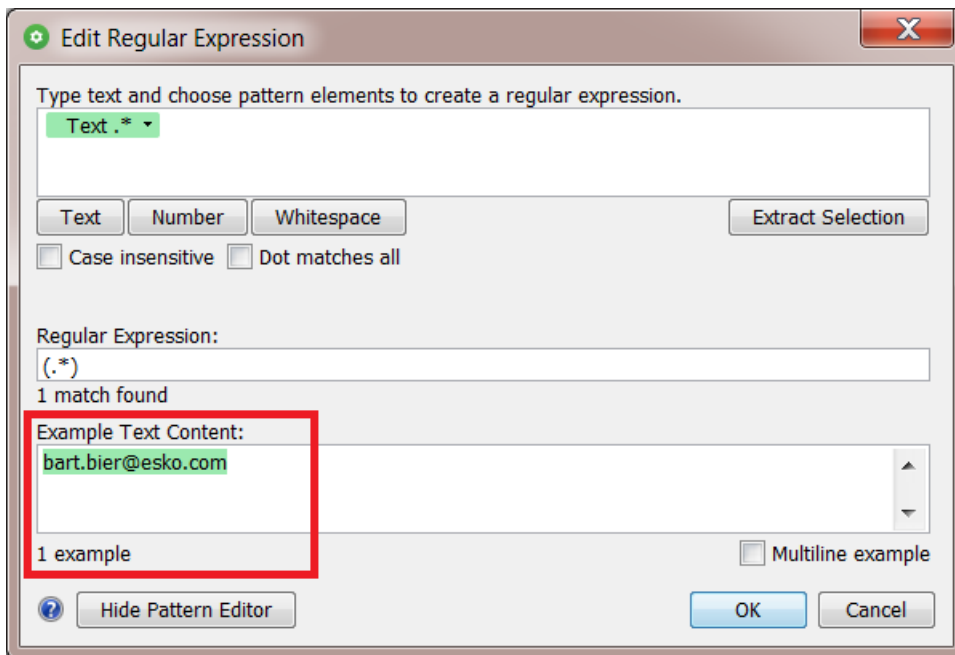

3. Analyse the pattern in your example text and re-create that pattern in the top field. To get the domain name from this E-mail address ( ' esko ' ), we need everything after the '@' and before the last '.' .

Follow these steps:

- After the text pattern (by default present and highlighted in green), type an '@'
- then click the **Text** button to add another text pattern

- then add a '.'
- then click **Text** to add another text pattern.

Notice how the Regular Expression has started building itself.

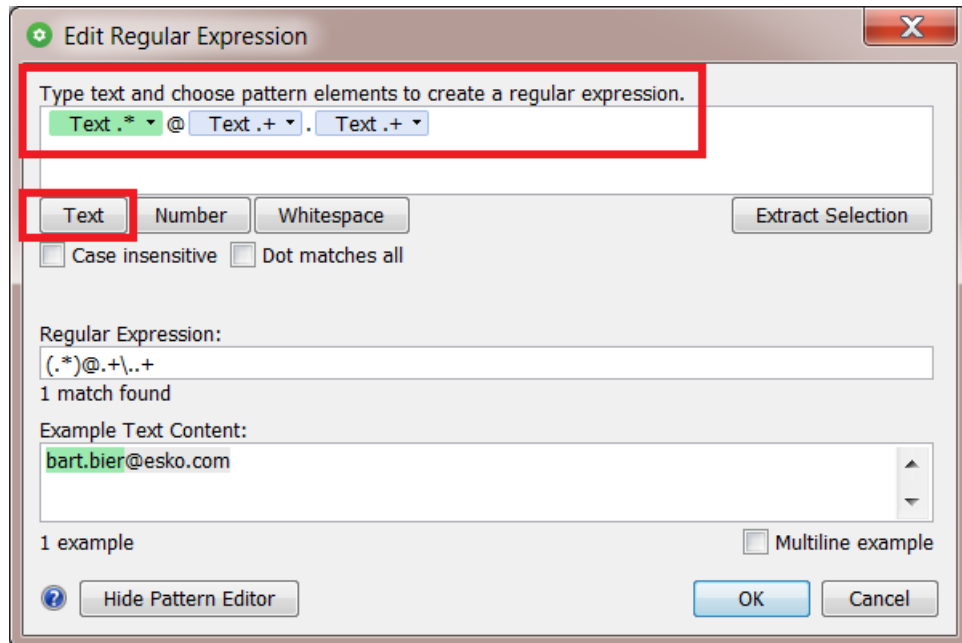

4. We need the text right after the '@', so we select the 2nd text pattern. This highlights it in blue. We then click on **Extract Selection**.

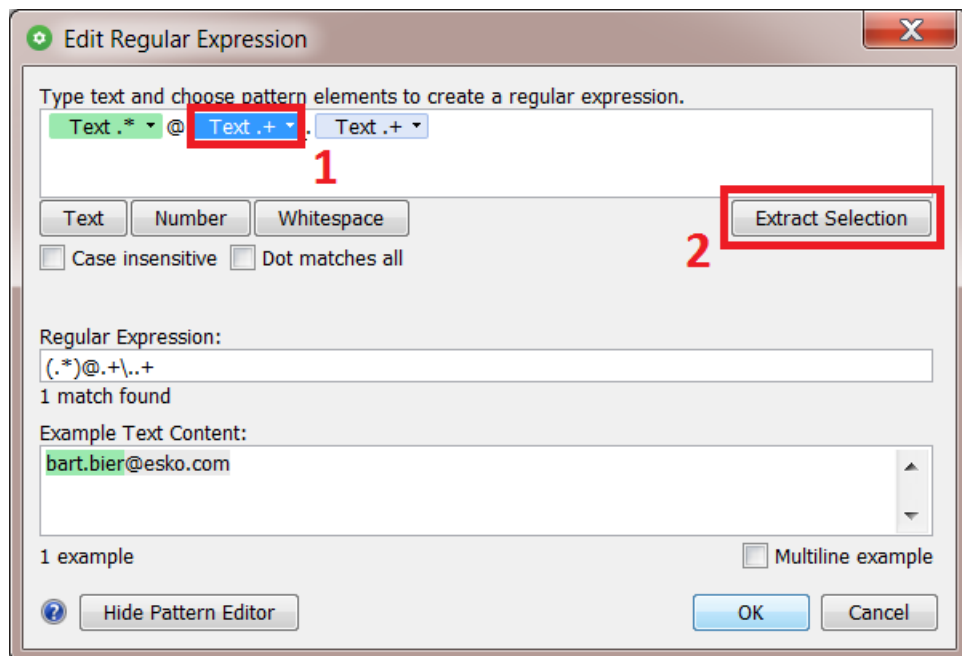



**Note:** You can also right-click the selected pattern and choose **Extract Selection** from there.

- The regular expression was updated. The part of the example text that this expression matches is highlighted in green.

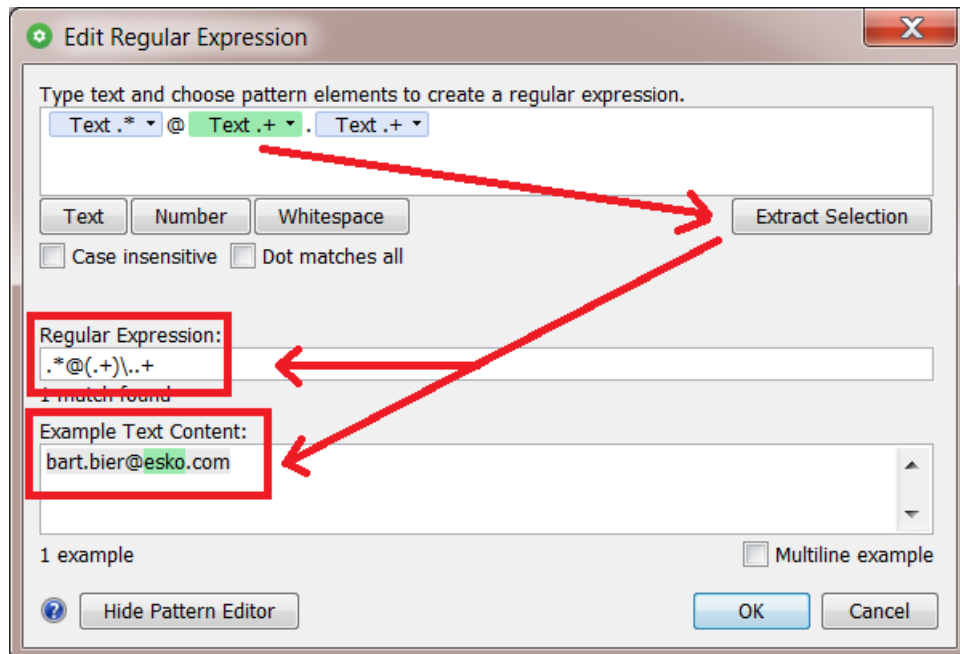

- When you see that the correct part of your example will be extracted, this means that the regular expression - that was automatically built - is correct. This expression will indeed extract the domain name from an E-mail address.



**Tip:** In this case, the pattern editor helped us create the regular expression. This also works vice versa: You can write or paste an expression in its field and when you then press 'Enter', the matching pattern will appear in the pattern editor above.

- Optionally, to further test that expression, you can add more examples. In every example, you want to see the part that will be extracted highlighted in green:

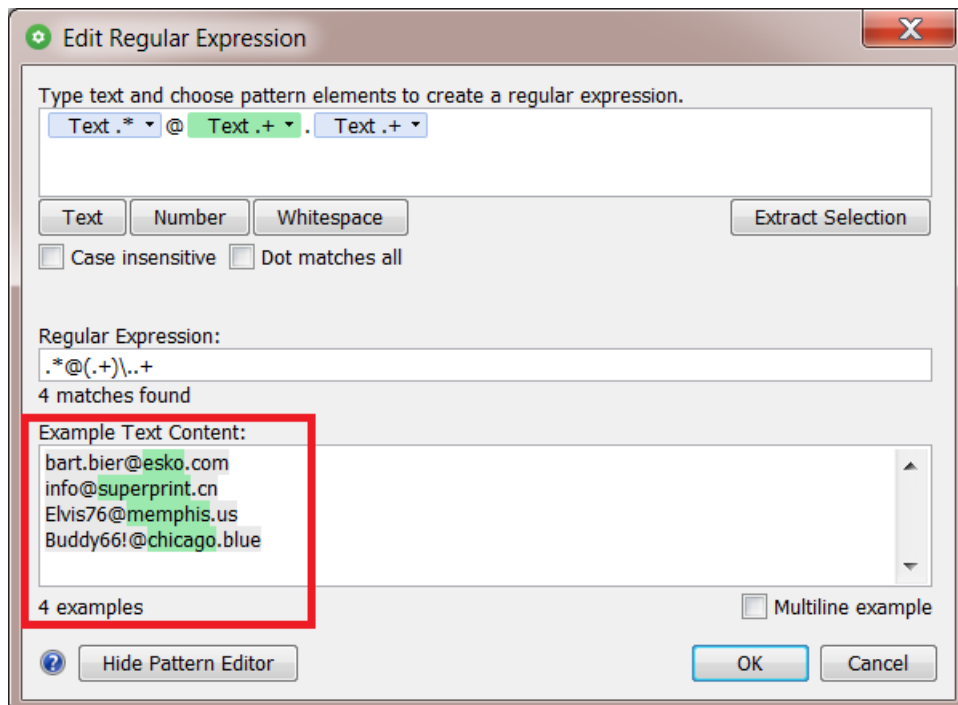

8. Click **OK** to close this panel and have the regular expression copied to the field from where you opened this tool.

### RegEx Example 2 - Extracting a Number at the End of a File Name



**Attention:** We here describe the case where the number always appears **after a known separator** character. This number could be a page number for example. [Example 4](#) shows what you could do when there is no character that you can use as a separator.

Follow these steps:

1. Add one or multiple examples of such file names in the below field (one per line). We here add 3 examples.
2. Then construct the pattern that re-occurs in these names:
  - Anything (**Text**)
  - followed by a '\_'
  - followed by a **Number**
  - followed by a '.'
  - followed by another **Text** for the file extension.

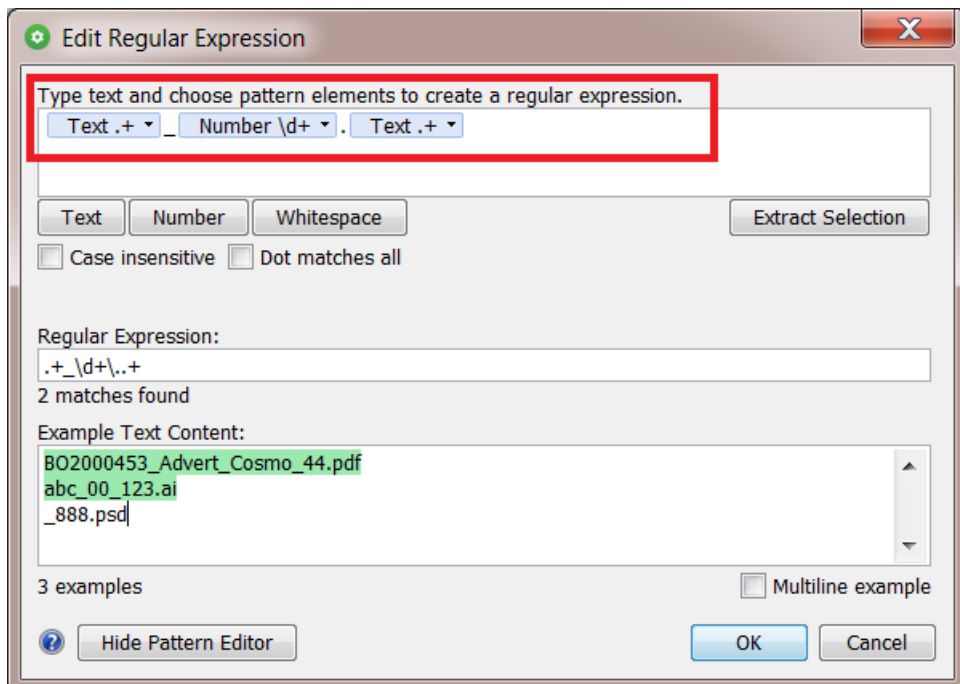

**Important:** In above image, you can notice that a text pattern can contain both letters and digits.

3. In the pattern field, select what you want to extract (the number pattern) and click on **Extract Selection**.

The examples highlight that result in green:

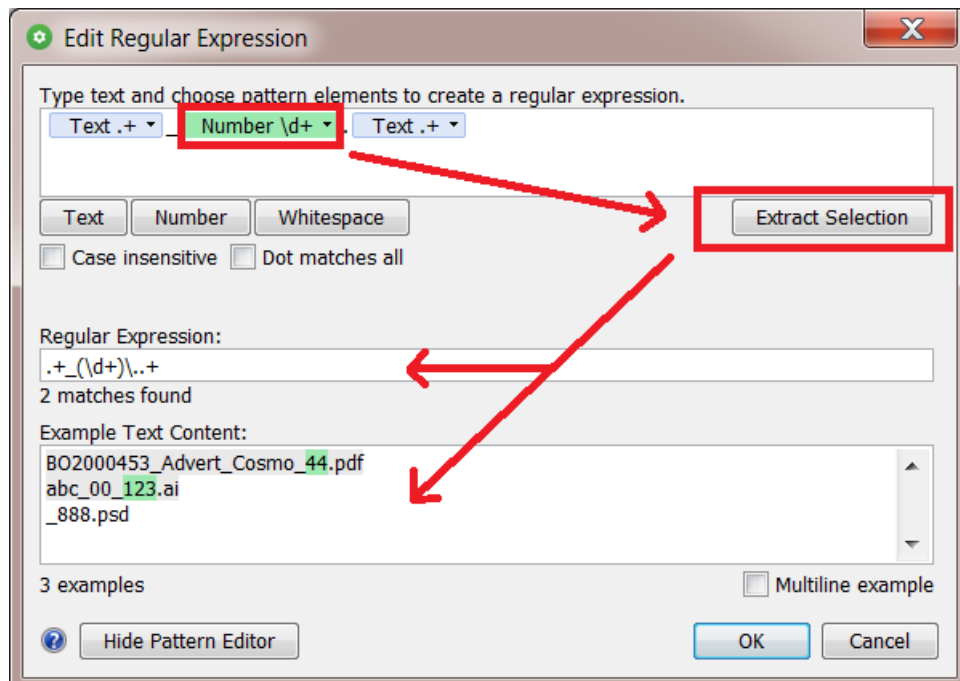

Notice how the 3rd example does not match the definition of the patterns. This is because it has no characters in front of its '\_'.

4. Click **OK** to close this panel and have the regular expression copied to the field from where you opened this tool.

### RegEx Example 3 - Extracting everything after the first underscore



**Note:** This example explains the option **Match as few characters as possible**.

Follow these steps:

1. Add one or multiple examples of file names containing multiple underscores (one per line).
2. Construct the pattern. We want to extract everything after the first '\_', **no matter how many '\_' there are in that name!**
  - We start by adding a text pattern,
  - then type an '\_'
  - and then add another text pattern.

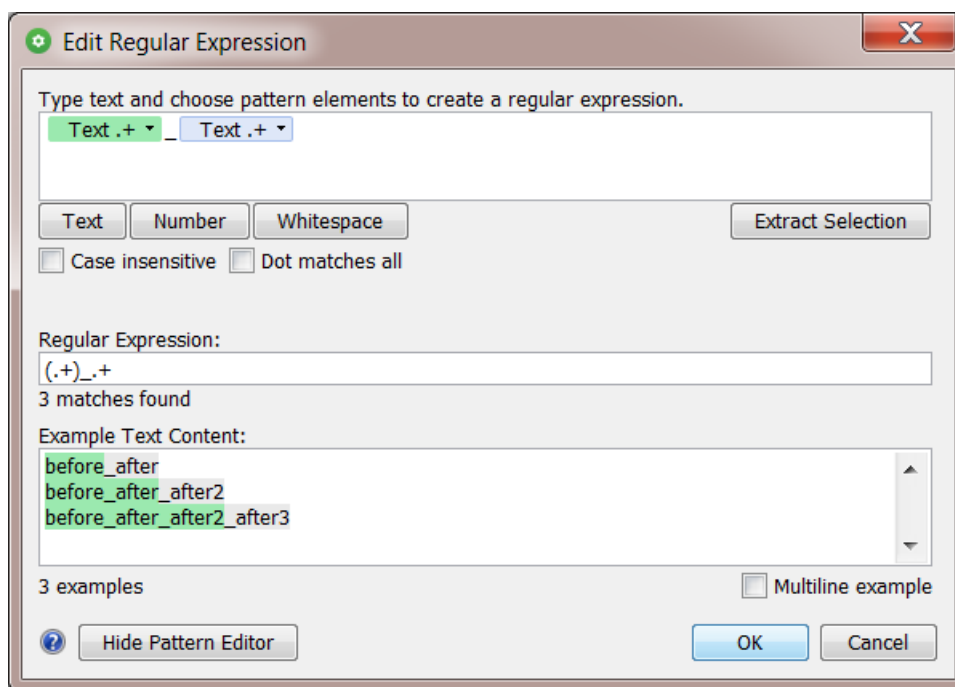

3. See above how the 3 examples show a different result. They seem to use the last underscore to decide the split of the name.
4. We need to specify that it is the **first** underscore that will decide the extraction. To do this, click on the small arrow on the right of the first text pattern. There, activate the option **Match as few characters as possible**. Click **OK**.

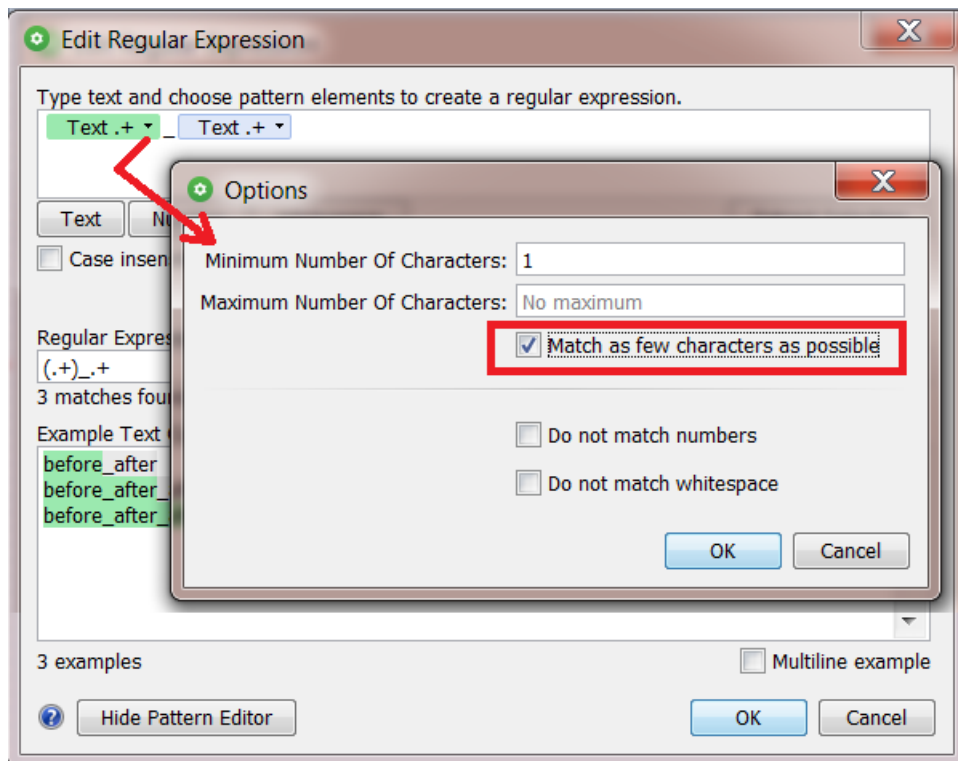

**Note:** See below how this option inserts a '?' in the regular expression and in that one text pattern. In [RegEx terms](#), this is also known as "non greedy".

5. Select the first text pattern and click **Extract Selection**.

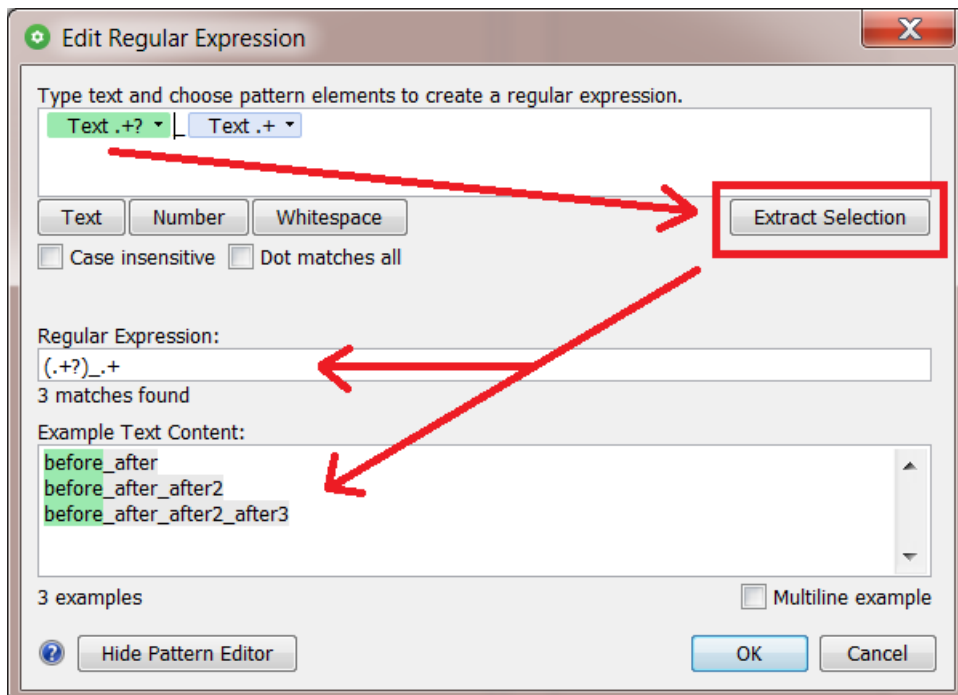



- We now see the result we want. In each example, only everything before the first '\_' is highlighted.

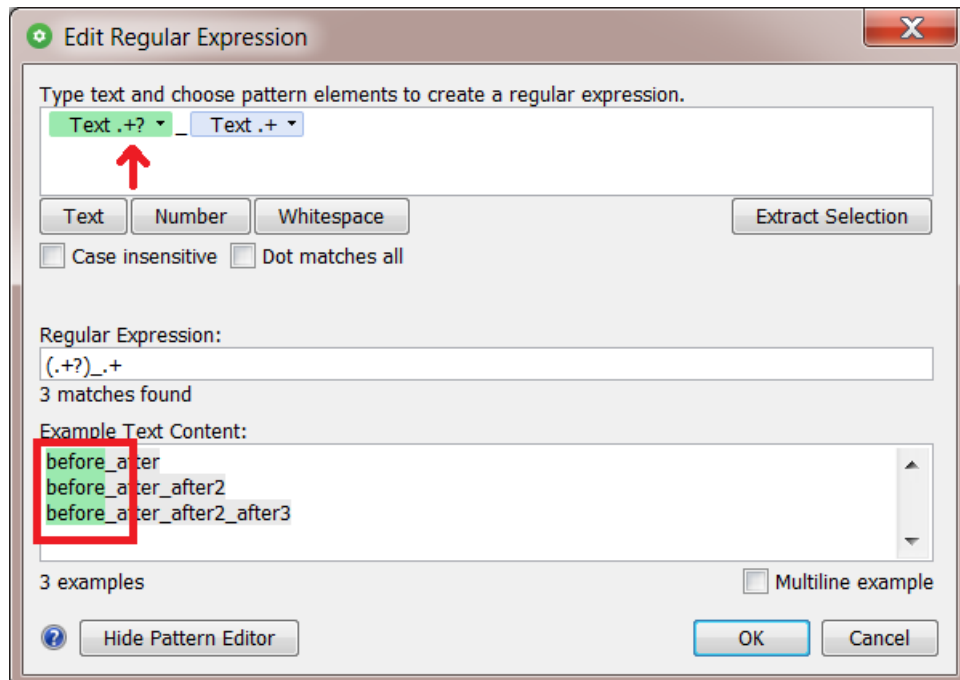

- Click **OK** to close this panel and have the regular expression copied to the field from where you opened this tool.

### RegEx Example 4 - Extracting a number without a separator character



**Note:** This one is very similar to [example 2](#), but here we also need the option **Match as few characters as possible** that we introduced in [example 3](#).

- We now have names of which we only want the numbers at the end of the file. We enter some examples and create the pattern:
  - Some text pattern,
  - followed by some number
  - and then a '.'
  - followed by some text (the file extension).

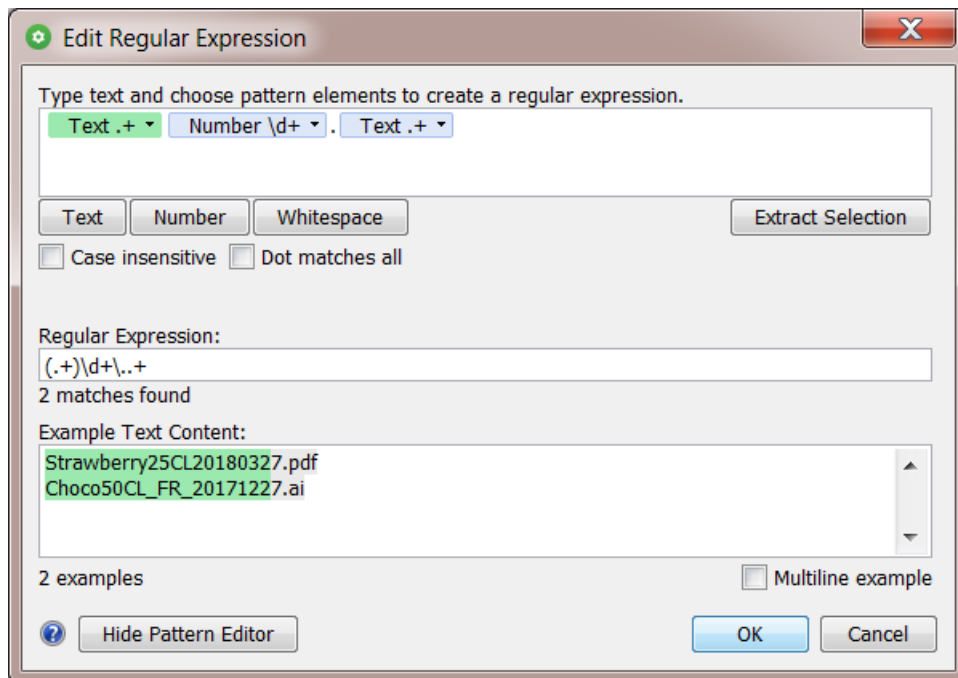

2. Notice in the above image how the text pattern tries to grasp all the characters possible (see the green part in the examples). It has to leave one number at least because there is still a number pattern before the '.'.



**Note:** This is a good example of the RegEx term "greedy".



**Note:** We mentioned earlier that a text pattern can contain both letters and digits.

3. By forcing the initial text pattern to match as few characters as possible (= the opposite of "greedy"), the numbers pattern now contains all numbers at the end of the file name. This is what we were looking for:

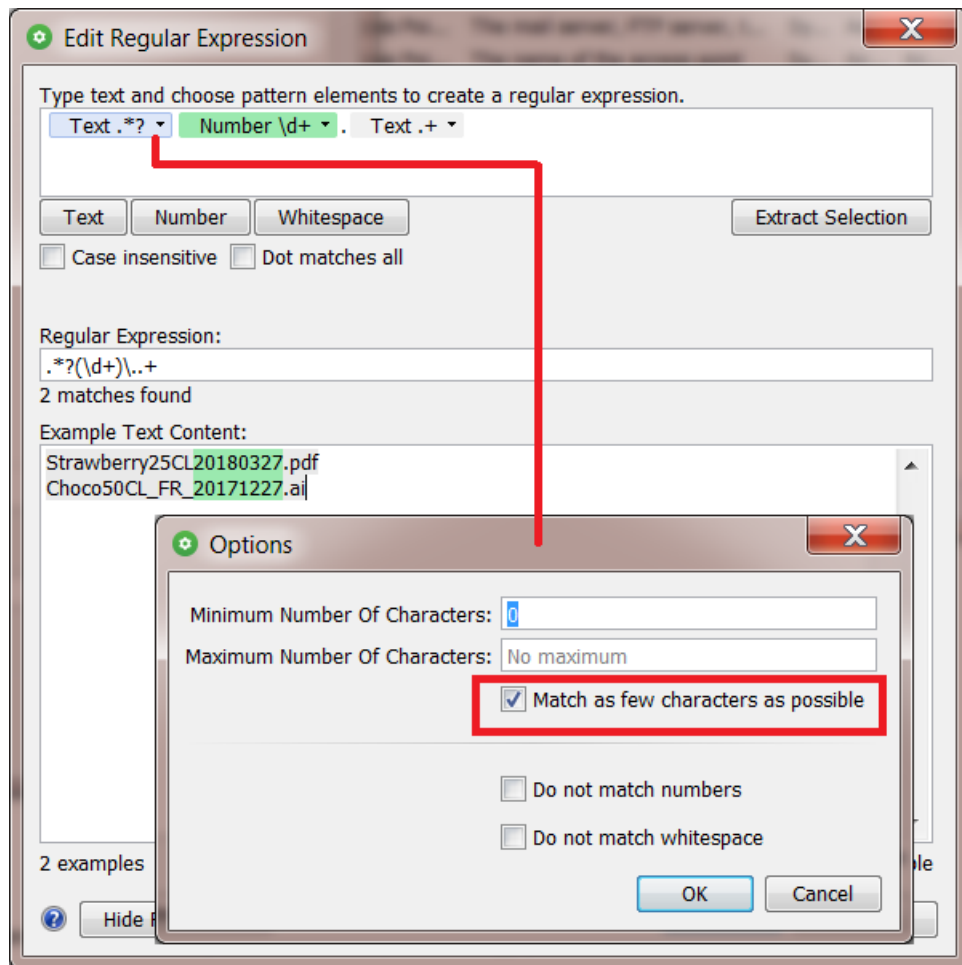

**Note:** The effect of this option is only visible after clicking **OK** in that '**Options**' dialog. What you see above is when you re-open that 'Options' dialog.

4. Click **OK** to close this panel and have the regular expression copied to the field from where you opened this tool.

### RegEx Example 5 - Extracting the last 6 characters or less, when another pattern allows it

We want to extract the last 6 characters, also when the input string has less than 6 (then we extract as many as there are). We also show how another pattern influences the result, depending if it's "greedy" or not.

Follow these steps:

1. After opening this editor, we enter these 6 example lines:

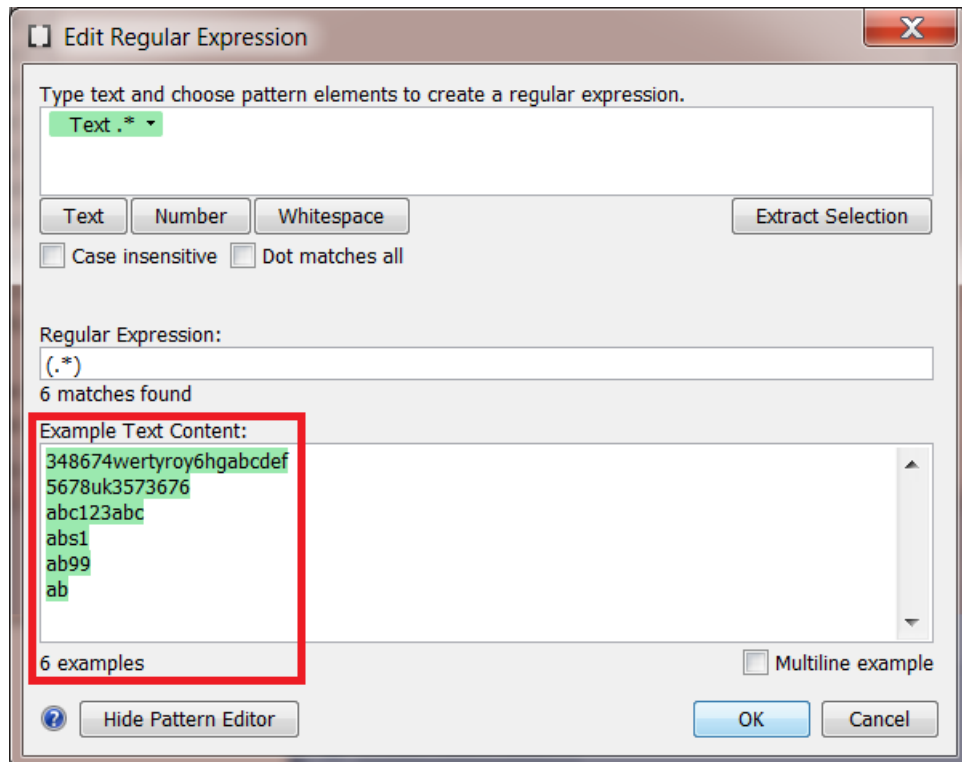

2. Click on **Text** to add a second text pattern. In that one, set the **Minimum Number Of Characters** to '1' and the **Maximum** to '6'.

This is what you see before you click **OK**:

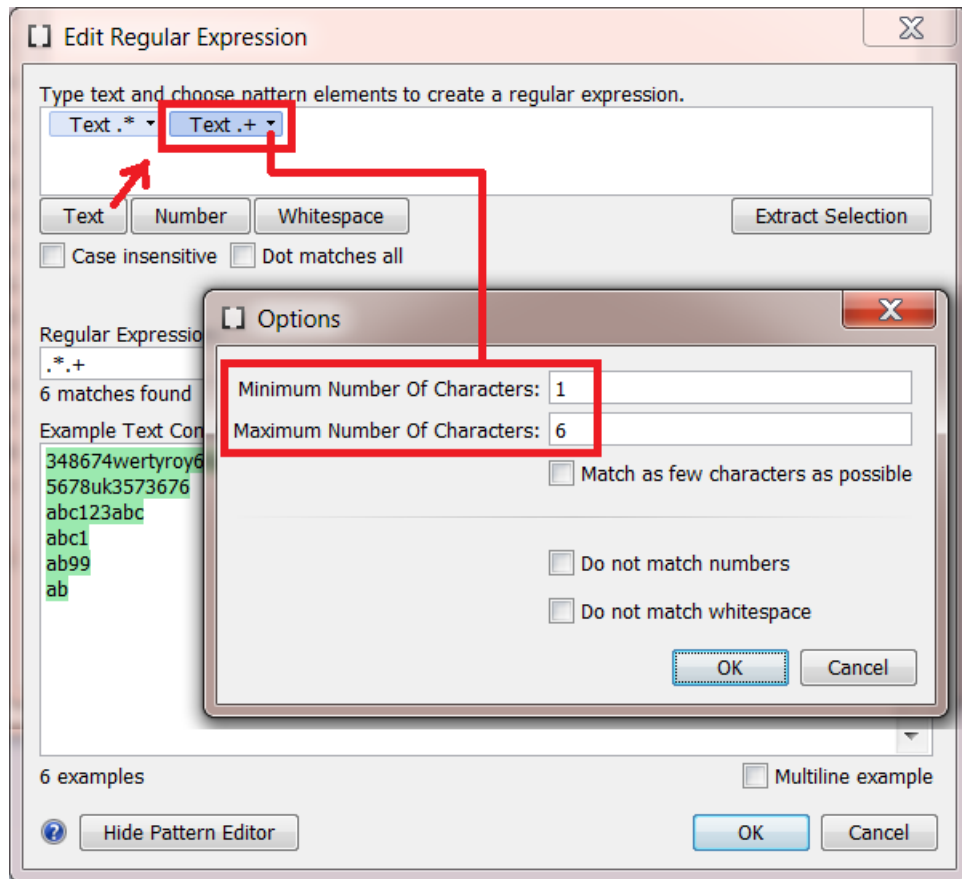

3. Click **OK** to confirm these options. Then, select the second pattern (darker blue) and then click **Extract Selection** to see what this pattern currently extracts.

See how, in all example lines, the resulting expression still only extracts the *last* character (green highlight):

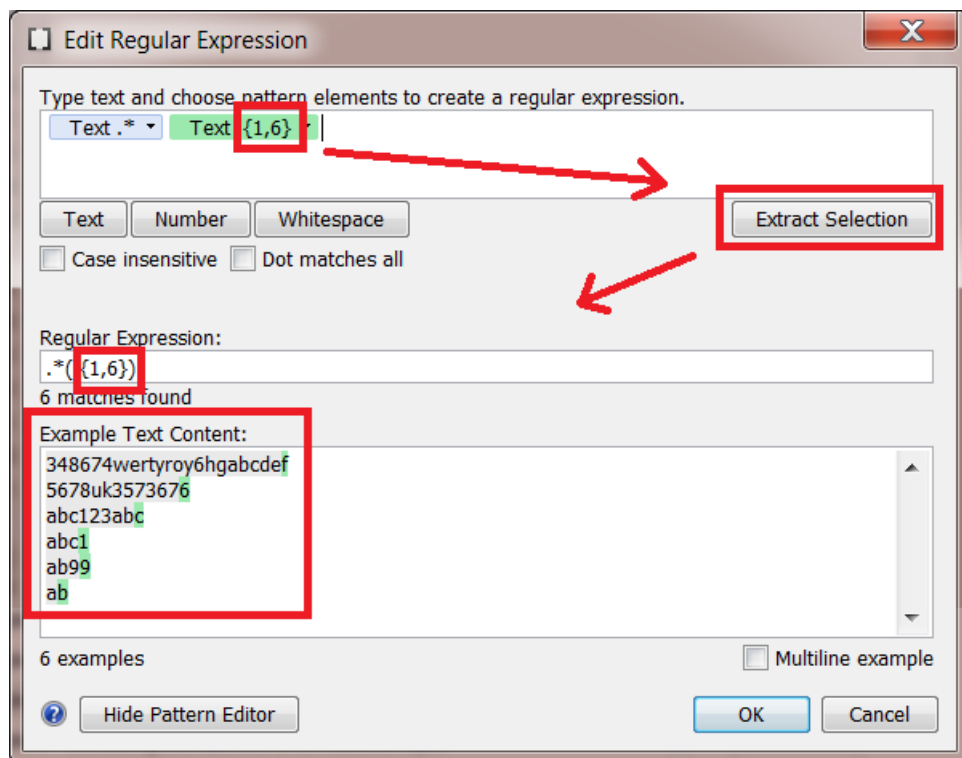

The reason that we don't see the last 6 characters in green is because of the other text pattern. That first pattern is also still "greedy": it tries to match as many characters as possible, which only leaves the minimum of 1 character for the second text pattern.

4. In the first text pattern, we now select the option **Match as few characters as possible**. This is how we tell it to "not be so greedy". We also set its **Minimum Number Of Characters** to '1'.

The combination of these 2 options means that this pattern will always take 1 character, possibly more, but leave the priority to the other patterns.

This is what you see before you click **OK**:

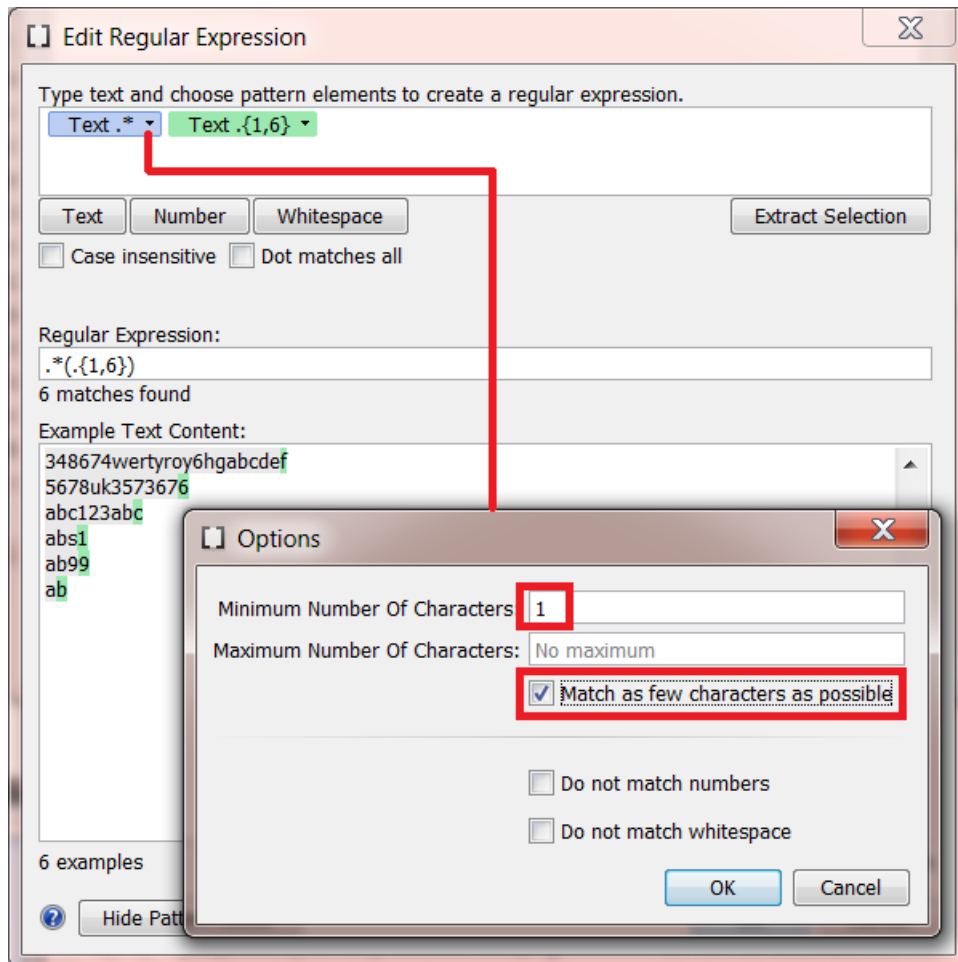

5. Click **OK** to confirm those options.

Now again select the 2nd pattern (darker blue) and click **Extract Selection**.

Our example lines now show that this expression extracts what we wanted:

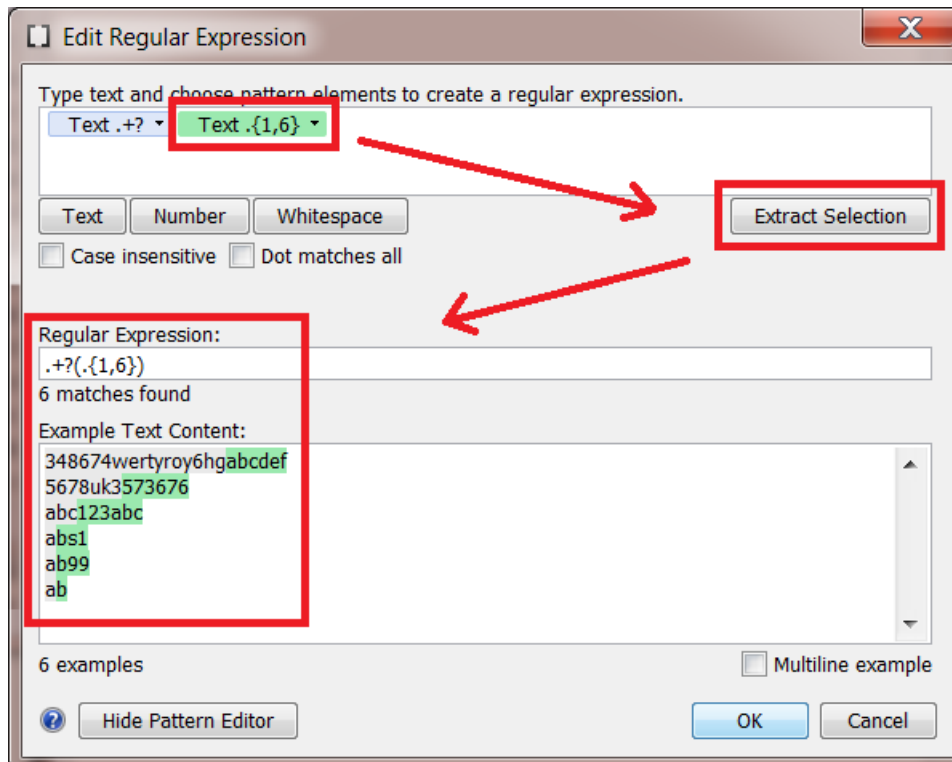

6. You saw above that patterns can influence each other. To also understand what the 1st pattern really does in our example, select it and click **Extract Selection**.

Our example lines now show that it minimally takes one character and then takes as many extra characters as the second pattern allows to take (which wants 6 maximum).



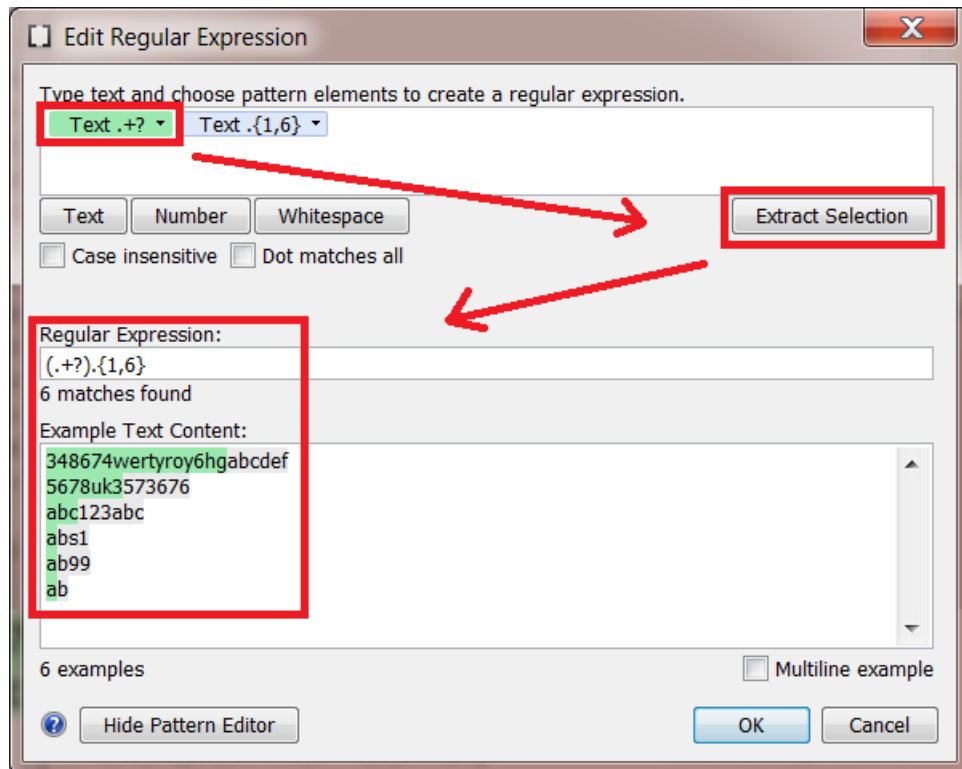

7. Before you click **OK** to close this editor and transfer the expression, make sure that the field **Regular Expression:** contains the expression you wanted ; in this case you want the one from the second pattern.

So, as you did in step 4, select the second pattern again and click **Extract Selection** to make sure the expression is `.+? (. {1, 6})`.

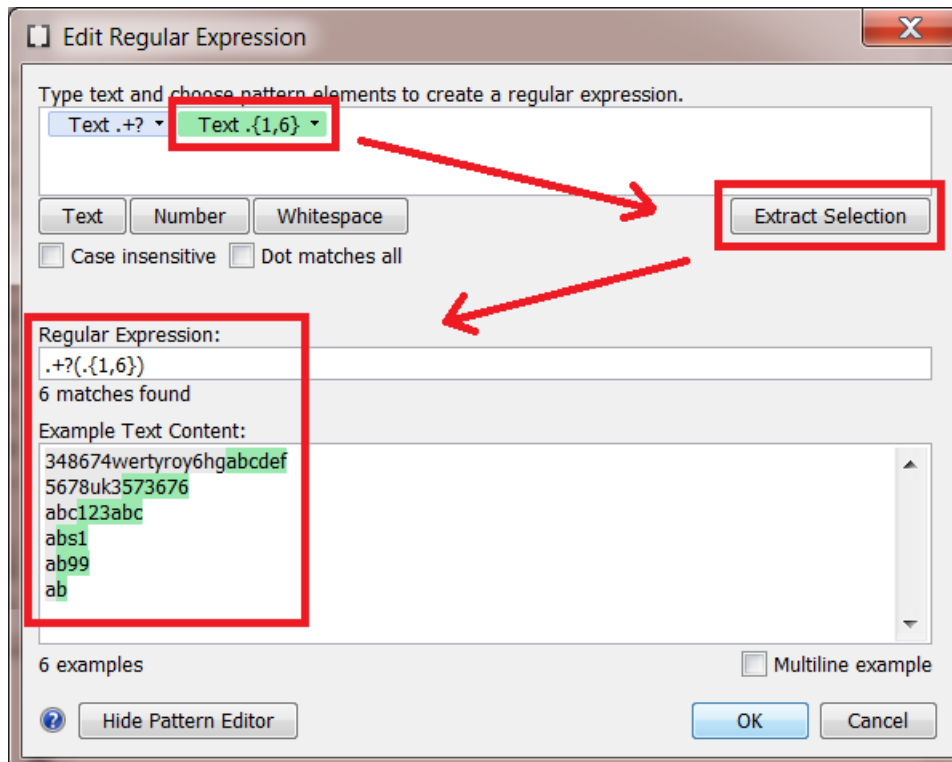

Then click **OK** to close this editor and have that regular expression copied to the field from where you opened this tool.

### RegEx Example 6 - Extracting the last line of a multiline input



**Note:** This example uses the option **Dot matches all**.

Our input (file) is a multiline document and we want to extract only the last line.

1. Our example text has 5 lines. When we set the option **Multiline example**, it is now seen as only 1 example.

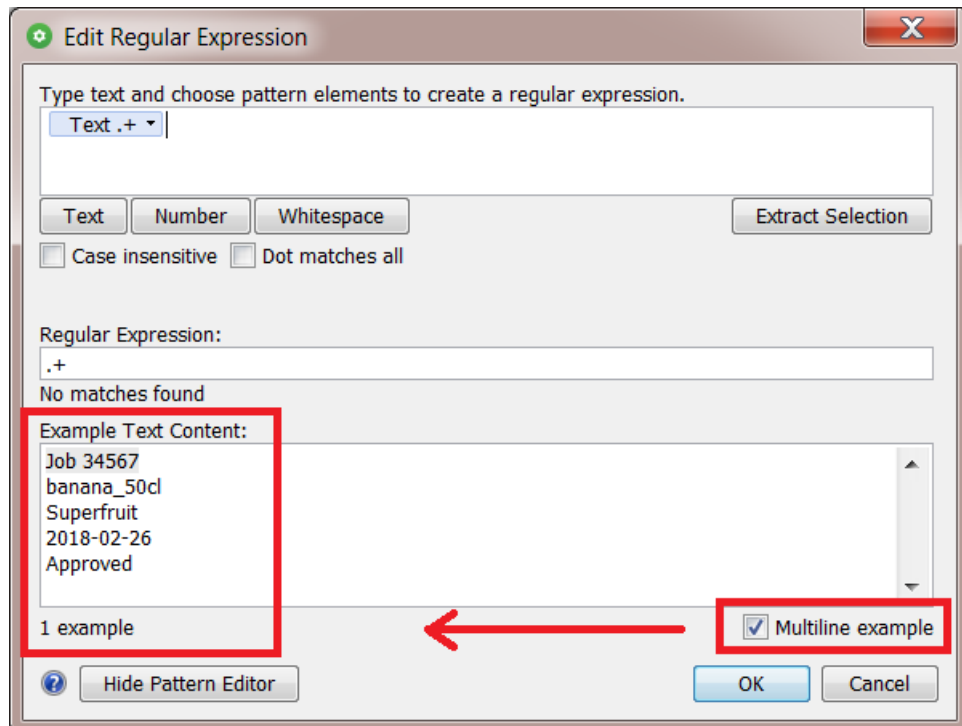

2. Add a text pattern \*below\* the first one. Set the option **Dot matches all**. In Regular Expressions, the regex dot character matches by default all characters *excluding* line break characters.

Activating this option makes it also see the line breaks. The below text pattern is now seen as the last line of text:

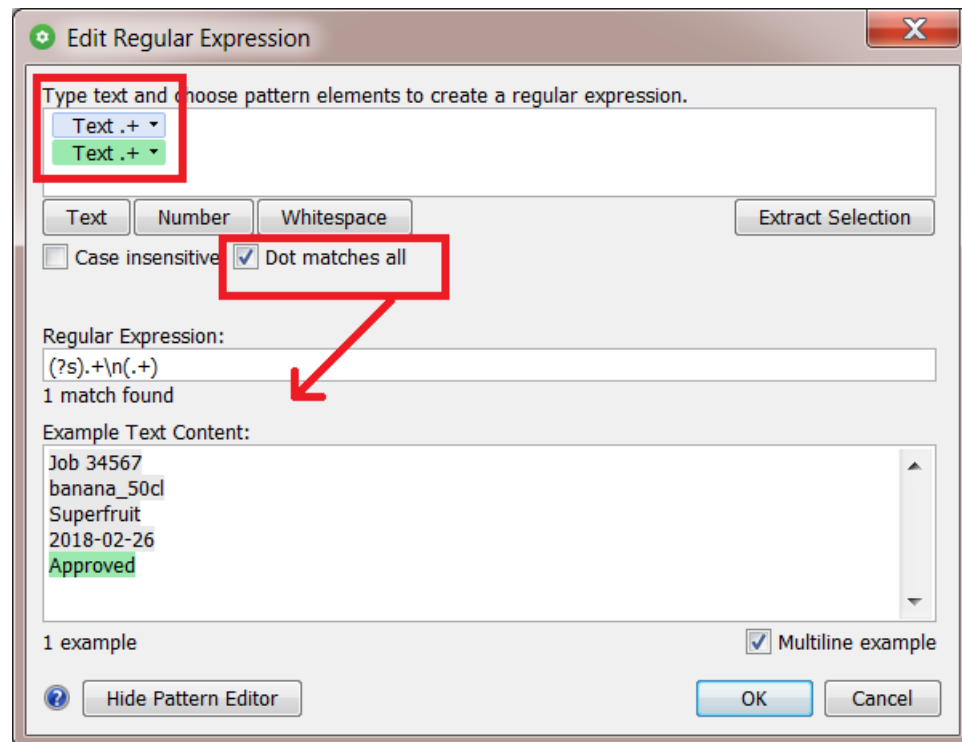

3. Click **OK** to close this panel and have the regular expression copied to the field from where you opened this tool.

### RegEx Example 7 – Selecting a specific range of files

This is an example that can be used in the **Select File** task.

In our example, we want to select *all* files *except* files starting with a '.' (the hidden MacOS files) and files of which the name ends with '\_report'.

1. In this task, the RegEx Builder is slightly different. You can add several rows of patterns. See the word **'or'** on its left side:

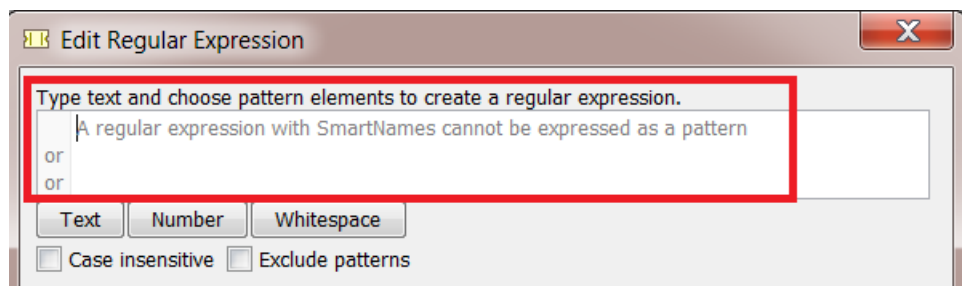

2. Construct this pattern:
  - We add the first text pattern to define all files starting with a '.'
  - Below that first pattern, we add a second one
    - that specifies a text ending with '\_report',
    - followed by a '.'
    - and then a pattern representing the file extension.

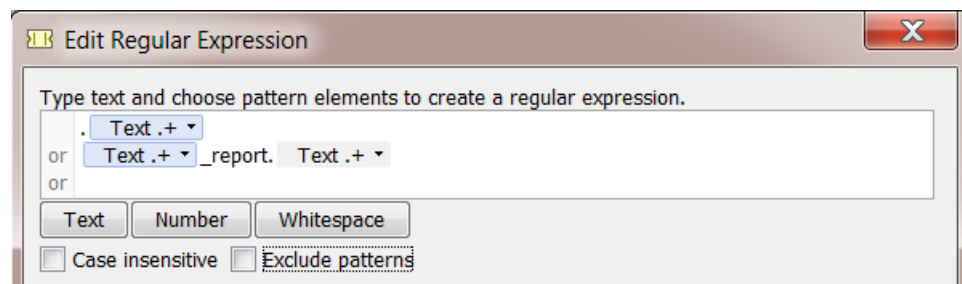

3. We add a few examples below. We see the first effect of our regular expression:

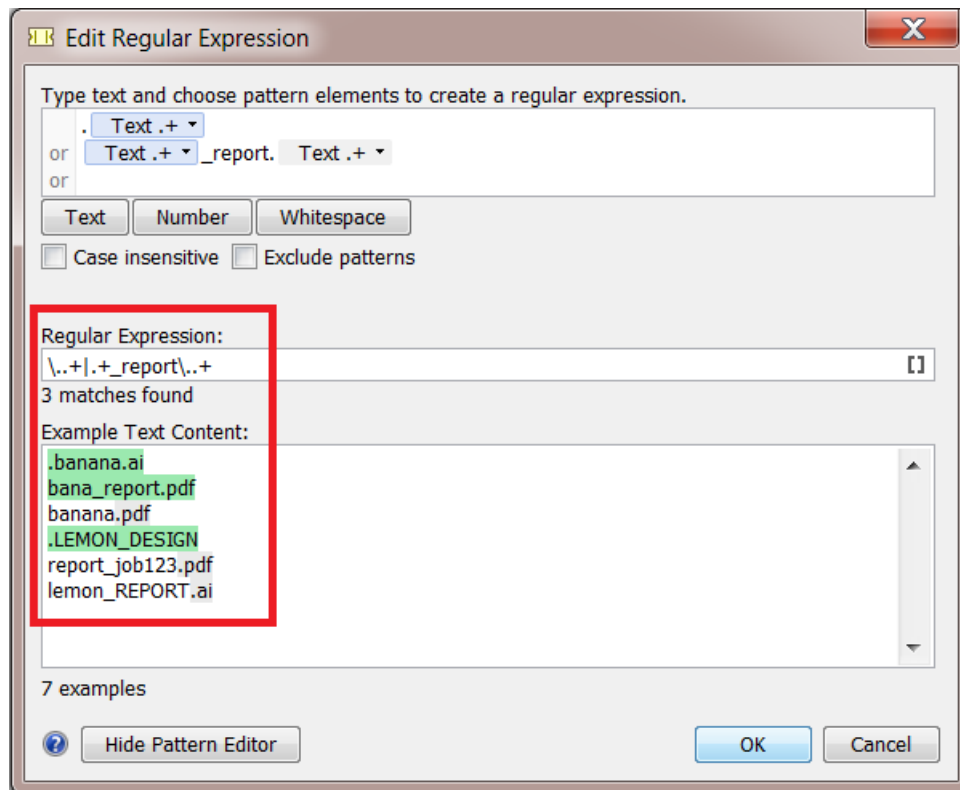

4. The result is not yet what we want. The file `lemon_REPORT.ai` was not matched. We correct this by indicating that this expression needs to be **Case insensitive**:

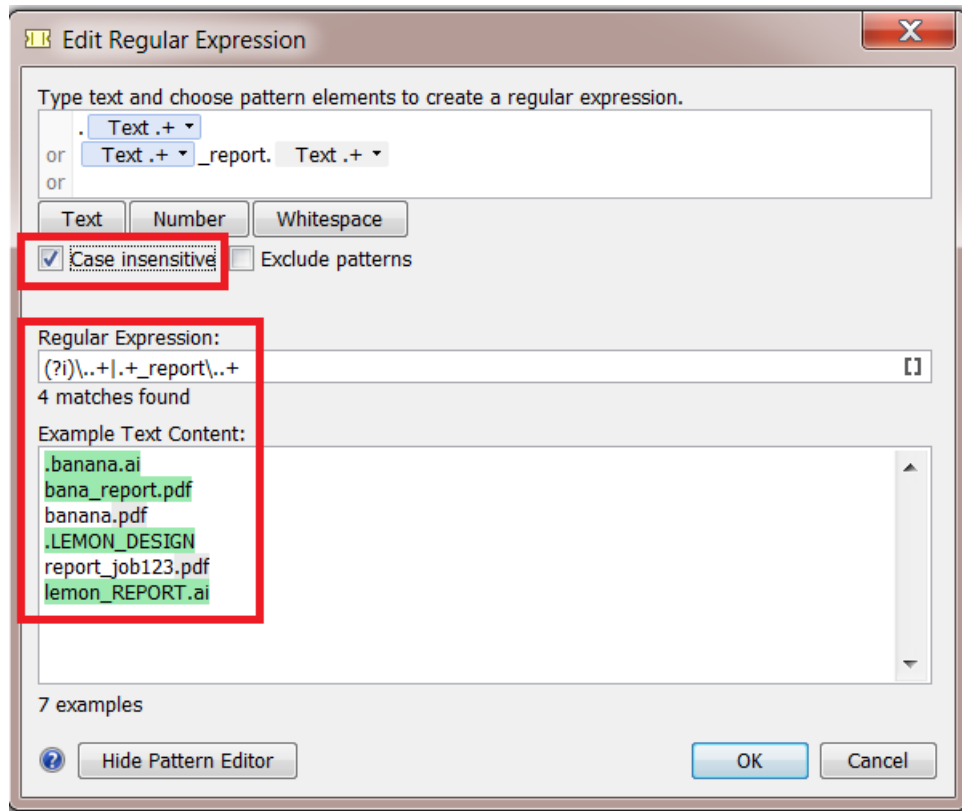

5. Now the regular expression matches all the files that we do not want:

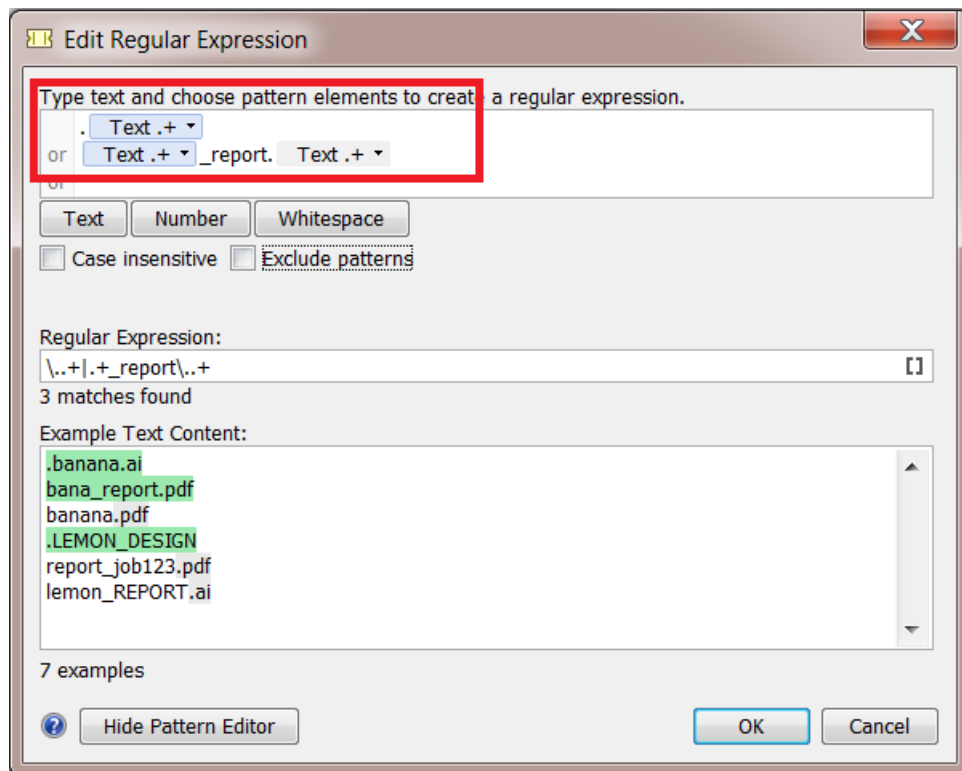

- By setting the option **Exclude patterns**, we reverse the logic. The patterns that we described are now used to exclude files from our selection. We now get the result we wanted:

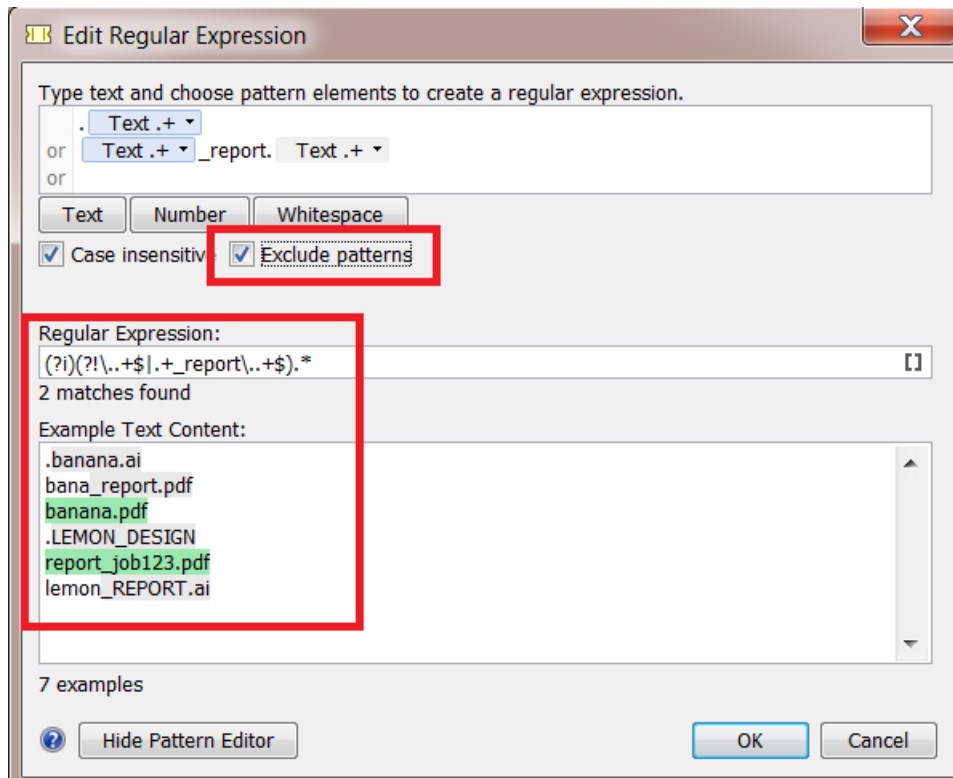

- Click **OK** to close this panel and have the regular expression copied to the field from where you opened this tool.

## 9.13. SmartNames of Parameter Values

The chapter "SmartNames" describes the many ways how to create a SmartName that will resolve in a string like "flexo" or "123". But how do you create a SmartName that resolves in **Parameter Values** that are not a text string?

For example you want a SmartName to decide a button in the interface that indicates to rotate 90 degrees. Or you want a SmartName to decide an internal value that is shown in a drop-down list, for example "any user".

We illustrate both cases with an example:

### Creating a SmartName that selects a Button in the user interface

Some buttons in task tickets can be transformed into SmartNames. For example step & repeat tasks have many buttons that you can also set via a SmartName.

Follow these steps to create such a SmartName:

- Select the button and then right-click the button to see if the option **Copy Parameter Value** appears. If so, select that option.

Below an example of the **Orientation** buttons for the marks that you can set in the task **Add Marks to Imposition**. See below how you can **Copy** their Parameter Value and how the list of buttons also offers to be decided by a SmartName.

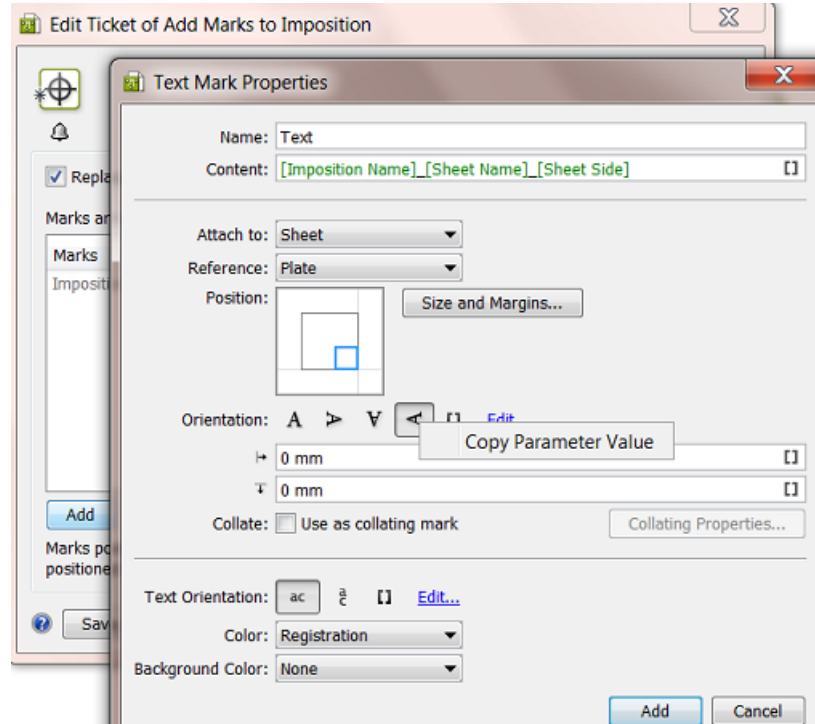

2. Go to the dialog where you create the SmartName, right-click and **Paste** the Parameter Value.

An example: Let's create a Job Parameter (which always becomes available as a SmartName). We here show the manual creation but it would normally be created automatically based on input from an external system. In the Job Setup, we create the Job Parameter **Text Mark Rotation** and for its **Value** we paste (**Ctrl-V**) the Parameter Value of the button. The screen shot shows that the resulting value is "270".

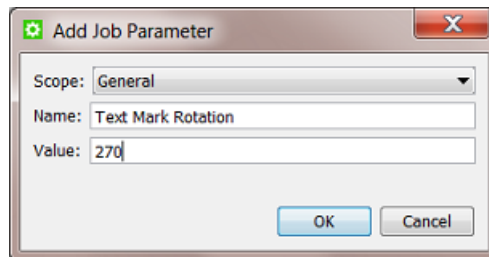

3. Now use that SmartName in the Ticket instead of the button. Click on the SmartName icon and select it.

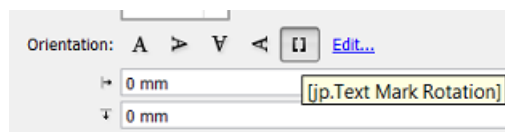



### Creating a SmartName of an Automation Engine internal value

This example shows how to create a SmartName that will return the value of "Any user" (a choice from a drop-down list):

1. Right-click the interface value and see if the option **Copy Parameter Value** appears. If so, click the option.

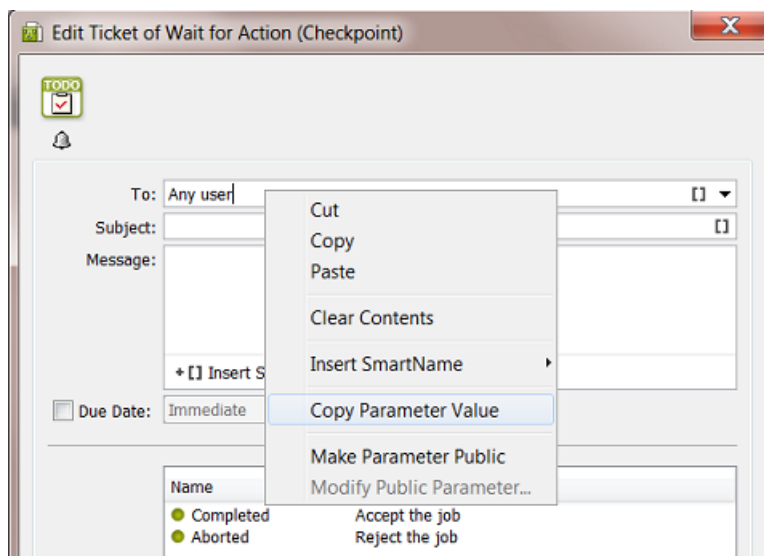

2. Go to the dialog where you are creating the SmartName and **Paste** the value there. You will see it appear as "Any User...@".

An example workflow: Your Jobs are created via XML files that you receive from your business system. The XML contains the name of the Esko user that should handle this Job and therefore should receive an item in his **To Do list** (from the **Wait for Action (Checkpoint)** task that is automatically started when the Job is created). The **Create Job** task maps that user to the custom **Job Category 5**. The **Wait for Action (Checkpoint)** task then picks it up as the SmartName **Job Category 5**.

For this to work, the business system needs to know exactly how to write the Automation Engine User names. In our example, the business system also needs to learn how to tell Automation Engine that the To Do of a Job is for **Any User**. In that case, the business system needs to mention in the XML that the Job is for "Any User...@", because only that value will match the drop-down choice **Any user**.

This screen shot shows how the **Create Job** task created the correct string in the custom Job Category named **ForWhichOperator**:

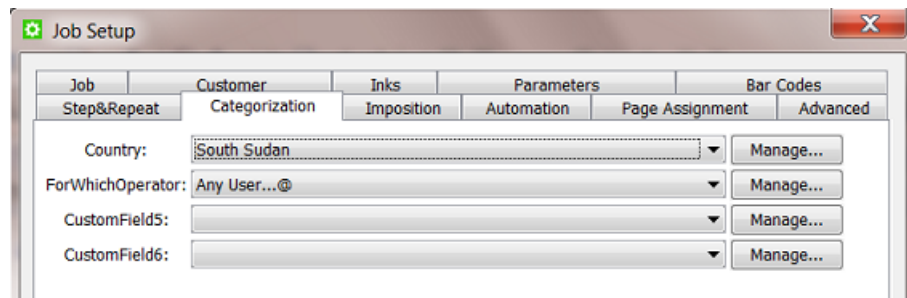

And the SmartName of this Job Category is then used in the **To:** field of the Checkpoint task:

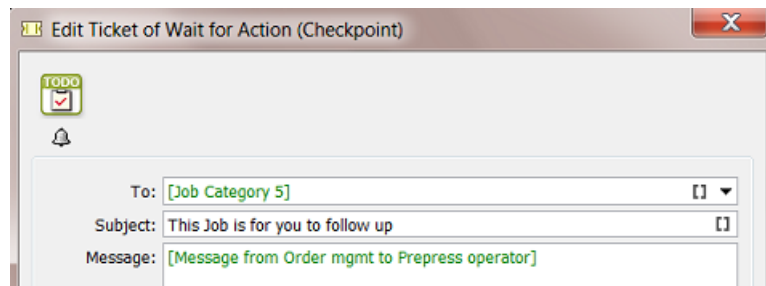

# 10. Workflows



**Note:** All screenshots in this chapter were made before version 22.03, which is when classic tasks were renamed to have a suffix 'Classic' and before the 'Dynamic' tasks suffix was removed from those working with the ArtPro+ (NDL) graphics engine. Learn about the different graphics engines in [Which AE task Uses which Technology?](#) on page 66 .

## 10.1. Workflow Basics

Automation Engine enables you to create very powerful and automated workflows. You can customize them to do exactly what makes sense in your environment. You can make them extra smart by using SmartNames, subworkflows, routing, integration points with external systems and much more.

A step in a workflow is an Automation Engine **Task** performing an action on an input file to produce an output file. It can be also be a **Workflow Control**. Workflow controls can be about deciding which route the workflow will take or about file management (selecting, sorting etc.) or about other administrative decisions in the workflow.

Here is an example introducing some main tools:



1. A **Transition** is the green line that connects each step in the workflow. It is a graphical representation of an output file of a step being used as the input for the next step.
2. By default each step has an OK and Error **Output Pin**. When a step ends in the OK state, the output file will be sent to the step connected to the OK output pin. When a step errors out the workflow will continue with the step connected with the Error output pin. In the example workflow above the **Preflight with PitStop** task has 2 extra pins, matching the possible Preflight statuses.
3. This **subworkflow** handles the approval process. This subworkflow opens when you double click it.
4. Here we used the workflow control **Router**.
5. See how this Router shows 3 output pins. When hovering over them with your mouse you see their name, in this case the route to 'Off site printing'.

Workflows can be started

- manually, by an Automation Engine user,

- using the Pilot or the [browser client](#)
- using the Shuttle client tool or the Shuttle plug-in on board Esko editors or Adobe Illustrator.
- automatically
  - by an Access Point
  - by an external system that was integrated with Automation Engine. This could be WebCenter or any non-Esko system.



**Note:** Learn more about Access Points and integrations in [Integrating with External Systems](#) on page 1769.

## 10.2. Building Workflows using the Workflow Editor

You can open the workflow editor from the Pilot using (from the **Tickets** view) or (from the **Files** view).

### 10.2.1. The Workflow Editor Window

The workflow editor window consists of these main areas:

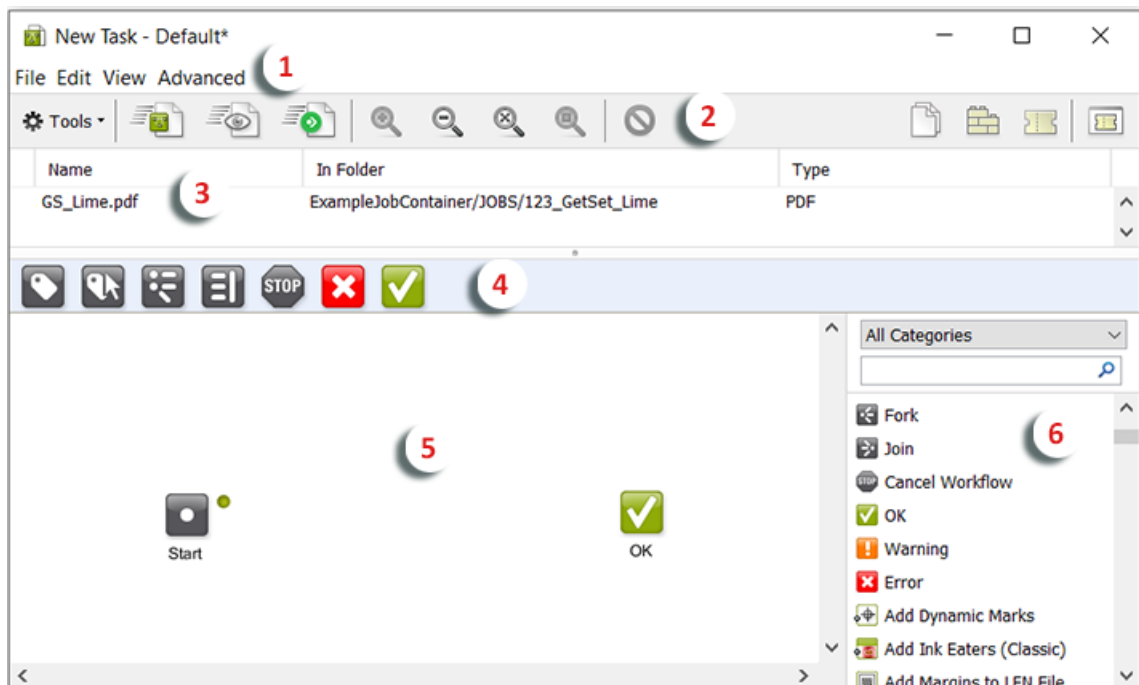

1. The workflow editor menus. Learn more in [The Workflow Editor Menus](#) on page 735.
2. The workflow editor tool bar. Learn more in [The Workflow Editor Tool Bar](#) on page 737.

3. The **Files** pane shows the files that you selected before opening this workflow (only when opened from the **Files** view) or it shows the files that you launched this workflow on. Enable or disable it via the menu **View > Hide / Show Files**.
4. The **Favorites** bar shows workflow steps that you often use when building workflows. You can then drag them from this bar down onto the canvas. Enable or disable this bar via the menu **View > Hide / Show Favorites**.

Add new favorites by drag and dropping new steps or custom tickets into this bar. Remove them via a right-click and click 'remove'.

5. The **canvas** shows your workflow. This is where you build it. You can monitor your workflow while it is processing files and you can diagnose a finished workflow. You can also print it (see [menu options](#)).
6. The **Tasks** pane lists all the types of steps that you can add to this workflow (steps can be task tickets and workflow controls). Enable or disable it via the menu **View > Hide / Show Tasks**.

To add a step to the workflow, simply drag and drop it onto the canvas.

You can easily find types of tasks by selecting a category and or using the filter and search field.

## 10.2.2. The Workflow Editor Menus

Some menu options are only available while creating a workflow, others are only available for a saved workflow ticket.



**Note:** Check the available menu shortcuts.







Use this menu...	to ...
<b>File</b>	<ul style="list-style-type: none"> <li>• <b>Launch:</b> To launch this workflow on the selected input file(s) (available when you selected a file before building the workflow). The workflow editor window will close.</li> <li>• <b>Launch And Monitor:</b> To launch this workflow on the selected input file(s) and keep the workflow editor window open so you can monitor its progress.</li> <li>• <b>Launch with Public Parameters...:</b> Select this when you prefer to use a launch dialog that only shows the public parameters of this workflow (in stead of all steps and all their parameters). When working with public parameters, an administrator that set them up and created the custom dialog can so get a preview of how other users will see this simpler interface. Learn about public parameters in <a href="#">Using Public Parameters in Workflows</a> on page 838.</li> <li>• <b>Select File...:</b> Select one or multiple files to launch in the workflow.</li> <li>• <b>Open:</b> Opens the selected step (alternative to double-clicking it).</li> <li>• <b>Save Ticket:</b> Saves your workflow and all its parameters in a (workflow) ticket.</li> <li>• <b>Save Ticket as...:</b> Saves your workflow under a different (ticket) name.</li> <li>• <b>Export Ticket...:</b> Saves your workflow on your client computer. Learn more about exporting workflows in <a href="#">Exchanging Workflows</a> on page 772.</li> </ul>

Use this menu...	to ...
	<ul style="list-style-type: none"> <li>• <b>Show Info:</b> Shows information about the workflow ticket: its <b>Name</b>, the <b>Task Type</b>, the <b>Tags</b>, whether or not the ticket is <b>Public</b>, a <b>Description</b> of the ticket.</li> <li>• <b>Show Parameter Inspector:</b> Use this tool to easily manage the ticket parameters of all the used tasks. Learn more in <a href="#">The Parameter Inspector</a> on page 780.</li> <li>• <b>Find:</b> Puts your cursor in the search field of the tasks pane and clears any previously entered text string.</li> <li>• <b>Search:</b> Puts your cursor in the search field of the tasks pane or highlights any previously entered text string.</li> <li>• <b>Close:</b> Closes this workflow editor window.</li> <li>• <b>Print:</b> Print your workflow canvas on a network printer. This function is only available when opening a saved workflow ticket from the Tickets view.</li> </ul>
<b>Edit</b>	<ul style="list-style-type: none"> <li>• <b>Undo</b> or <b>Redo</b> your latest changes. The menu option also mentions which type of change it can undo. For example: '<b>Undo Change Parameters</b>' or '<b>Undo move</b>' etc.</li> <li>• <b>Cut</b>, <b>Copy</b> or <b>Paste</b> the selected step(s). You can also copy-paste between multiple workflow editor windows. You can define where the copy will be placed by using the right-click function.</li> <li>• <b>Select All</b> workflow steps.</li> <li>• <b>Delete</b> the selected step.</li> </ul>
<b>View</b>	<ul style="list-style-type: none"> <li>• Change the zoom of the workflow to its <b>Actual Size</b>. Alternatively, you can also <b>Zoom In</b>, <b>Zoom Out</b>, or <b>Zoom to Fit</b> in the window. Check the available shortcuts.</li> <li>• <b>Show / Hide Favorites, Files, Tasks</b> and <b>Sticky Notes</b>. Learn more about sticky notes <a href="#">here</a>.</li> <li>• <b>Show / Hide Grid</b> shows or hides the canvas grid. Activate <b>Snap to Grid</b> to more easily align your workflow steps on the canvas.</li> <li>• <b>Expand</b> or <b>Collapse</b> the <b>Queue</b>. When a workflow is running, a Queue is the vertical list of icons of workflow items that are being processed by a same step. These items represent (grouped) files or concepts like Job, Plate etc. If the amount of these icons is disturbing, choose to collapse that queue.</li> </ul>
<b>Advanced</b>	<ul style="list-style-type: none"> <li>• <b>Add / Remove</b> this workflow ticket to / from your <b>Favorites</b> bar.</li> <li>• See a processing <b>Log</b> (when the workflow is running). You can also send the Log contents as an E-mail.</li> <li>• Set up <b>Task Options: Priority, Hold / Release, Launching a separate task per input file</b> and <b>Annotations</b>.</li> </ul>

Use this menu...	to ...
	<ul style="list-style-type: none"> <li>• Set up <b>Notification Rules</b>. Learn more in <a href="#">Creating a Notification Rule</a> on page 227. Tip: check if using the separate <b>Send E-mail</b> task is a better alternative.</li> <li>• <b>Manage Workflow Parameters...</b> and <b>Workflow Parameter Values....</b> Learn more about these in <a href="#">Using Workflow Parameters</a> on page 859.</li> <li>• <b>Manage Public Parameters</b> for the selected step or check and <b>Modify Public Parameter Values</b> for the whole workflow. Learn more in <a href="#">Using Public Parameters in Workflows</a> on page 838.</li> <li>• <b>Validate</b> the current workflow (including all subworkflows). Any problems will be shown and explained in a separate dialog.</li> </ul>

### 10.2.3. The Workflow Editor Tool Bar



The tool bar offers buttons to:





- Perform specific actions on the workflow ticket:  **Tools**. All available actions are explained in [The Workflow Editor Menus](#) on page 735.
-  **Launch** the workflow on the selected files and close the workflow editor (only available when you opened the workflow editor from the **Files** view).
-  **Launch and Monitor** the workflow (without closing the workflow editor).
-  **Launch using Public Parameters**: Select this when you prefer to use a launch dialog that only shows the public parameters of this workflow (in stead of all steps and all their parameters). When working with public parameters, an administrator that set them up and created the custom dialog can so get a preview of how other users will see this simpler interface. Learn about public parameters in [Using Public Parameters in Workflows](#) on page 838.
- Change the zoom in the workflow canvas (zoom in , zoom out , zoom to fit )



**Tip:**

You can also use these shortcuts:

- **Ctrl + Space** (on Windows) or **Space + Cmd** (on Mac) to activate the zoom in tool, then click or drag in the window.
- **Ctrl + Alt + Space** (on Windows) or **Cmd + Option + Space** (on Mac) to activate the zoom out tool, then click in the window.
- Scroll your mouse up or down to move the whole workflow up / down in the window. Add **Shift** to move left-right.
-  **Delete** the selected step(s) from the open workflow.
- Show / hide panes (areas within the window):
  - : The input **Files** (when opened from the **Files** or **Tasks** view).

- : **Search:** Search your workflow for names of tasks or any of their parameter names or values. Learn more in [Searching Parameters in a Workflow](#) on page 799.
- : **Warnings:** A list to help you validate this workflow. Learn more in [Checking a Workflow's Warnings](#) on page 800.
- : **Tasks:** The types of tasks and workflow controls (their default tickets).
- : The **Resources** this workflow contains. Learn more in [Checking the Resources your Workflow contains](#) on page 803.
- : **Ticket Browser** shows available tickets in a separate dialog.



**Tip:** Use **Ctrl + click** or click and drag to select multiple steps.

### 10.2.4. Building a Workflow from Scratch

1. In the **Tickets** view, click  to open the workflow editor.



The canvas shows these two workflow controls by default: Start and OK .

2. Drag and drop the desired steps from the tasks pane onto the canvas.



**Note:** If the tasks pane is not visible, click **View > Show Tasks**.



**Note:** To find a task quickly, you can use the filter-by-category and/or the search field.

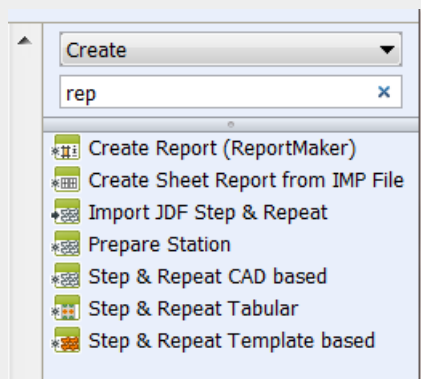





**Note:** On a workflow canvas, task types that use *classic technologies* are indicated by an extra suffix 'classic'.



This way, you can see it is a classic task even when you renamed the workflow step. The ticket dialog also shows a blue top bar with some information. An example:

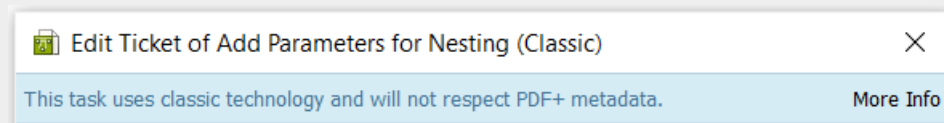

3. If you want to give one or more steps a more descriptive name to make the workflow self documenting, double-click the name underneath the icon and change it. You can still see the original name of the step by hovering over the step.

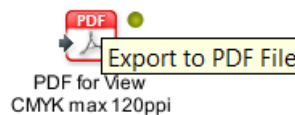

4. Connect your steps with one another. To do this, click on a step's green output **Pin** and drag it onto the next step.

This will link the two steps with a green arrow, called a **Transition**.



**Note:** Remove the transition by selecting the end part (arrow point) and dragging it away from the step that it was connected to.

**Note:** You can connect a step's output to multiple other steps. These steps will receive the same input file and will execute in parallel. An example:



**Note:** When you move your mouse to a point where multiple transitions come together, they will split up to make it easier for you to pick one of them (see below). When you want to move them together, hold the **Alt** button to select and move them together.

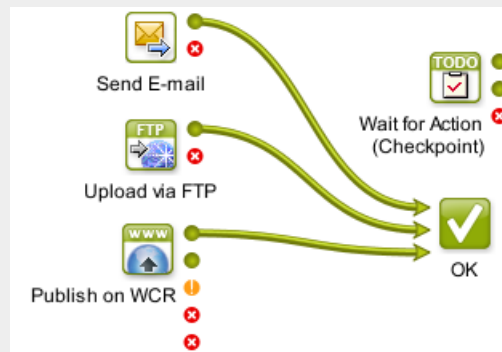

**Tip:** Learn more about keeping your workflow clean in [Visual Optimizations of a Workflow](#) on page 744.

5. Double-click each step and fill in its ticket parameters. Click **OK** to close the ticket. There is no need to save changes to each step ; their settings will be saved inside the workflow ticket.
6. Save your workflow using either:
  - **File > Save** or **Ctrl + S**,
  - **File > Save As...** or **Ctrl + Shift + S**.

**Note:** Until your workflow is saved, you can undo your changes. In **Edit > Undo** you can read which change can be undone.

**Note:** Until you save your changes, the name of the workflow will show an \* behind it's name.





**Tip:** Before saving your workflow, it is good practice to check its validity. Use **Advanced > Validate Workflow** or **Ctrl + Alt + V**.

## 10.2.5. Building a Workflow using Custom Tickets

Compared to *building a workflow from zero*, using already made custom tickets as workflow steps adds these extra possibilities:

### Using the Ticket Browser

In the tool bar of the workflow editor, click  to open the **Ticket Browser**, a pop-up dialog.

 Shows the complete list of tickets, sorted per task type.  Shows only the tickets of the selected task type.

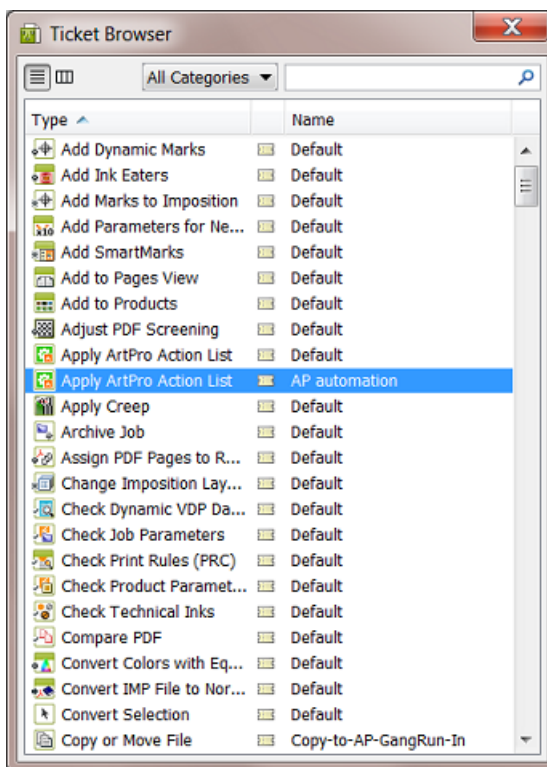

1. Use the **Categories** filter and /or the search field to quickly find your custom ticket.
2. Select and drag the ticket onto your workflow canvas.



**Note:** Alternatively, you can choose to not use this **Ticket Browser**, but use the **Tasks** pane, right-click in the list and select **Show Custom Tickets**.

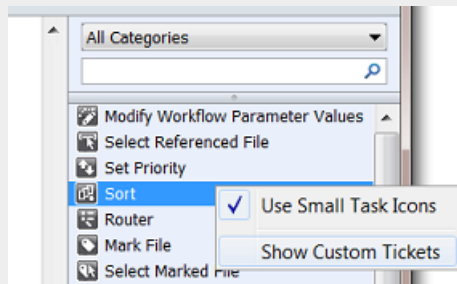

### Custom Tickets in your Workflow can be Copies or References

- **Copy:** When you add a custom ticket onto your workflow canvas, it is by default a *copy* of that ticket. This means that any changes you make to that ticket will *not* be reflected in the original ticket and vice versa.
- **Reference:** When you hold **Ctrl + Shift** or **Cmd + Alt** (Mac only) *while* you drag a custom ticket onto your workflow canvas, you add *reference* to that ticket to your workflow. This means that any changes you make to the ticket will also be done in the original ticket and vice versa.



**Note:** This is equally valid when your ticket is a workflow ticket.

Referenced tickets also show their original name, with a small arrow in front. Below example shows 3 workflow steps: a copied ticket on the left, a referenced one in the middle and on the right a referenced one that was renamed in this workflow but whose original name is still shown in grey below, next to the small arrow.



**Note:** If the ticket that you refer to in your workflow uses any SmartName containing [ ... originating Input ... ], be aware that this will reflect to the input of the ticket that you refer to, not of the workflow that refers to it.

### Adding a Part of another Workflow to your Workflow

If you want to add parts of a workflow to another workflow, follow these steps:

1. Open both workflows in a workflow editor.
2. Select a part of one workflow and choose **Copy**.
3. Click on the canvas of the other workflow and choose **Paste**.
4. Add the desired transitions and save your new workflow.



**Note:** If you plan to reuse workflows or parts of a workflow several times, we advise to create subworkflows. Learn more in [Subworkflows](#) on page 747.

### 10.2.6. Configuring Output Statuses

For each workflow task step, you can customize what to do when the task results in warnings or errors. You can also choose to add extra output pins.

Right-click the workflow step and select **Configure Outputs...**



**Note:** The offered options and the precise words are different per type of task.

- **Warning handling**
  - Select **OK on Warning** to send the files to the **(Finished) OK** output pin.
  - Select **Error on Warning** to send them to the **(Finished with) Error(s)** output pin.
  - Select **Dedicated handling of Warning** to send them to the **(Finished with) Warning(s)** output pin.
- **Add an extra output pin where the task's inputs will be (when no errors occur).** This is useful when the output file of your task is different from the input file and when you (also) want to continue working on the input file. Typical examples are when you create a report PDF or a Step & Repeat and you (also) want to continue launching steps on the one-up.

See this example, where the 2nd green output pin 'Inputs' allows further steps on the one-up:

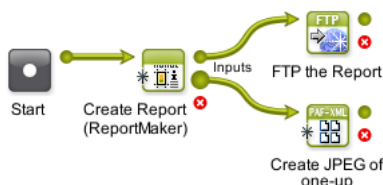

- **Add an extra output pin where the task's reports will be put.** Tasks that also output a separate report file (like the Preflight tasks) offer this extra choice. You can then connect that extra 'Reports' pin to the workflow step that will handle that report file.

See this example where the Preflight report goes to its own output pin 'Reports':



- **Cancel automatically.** In some special cases, a task can remain in a running state for an abnormally long period, and possibly even create a queue problem. For example a 'Run Script' task that ran into a problem or waits for something in vain.

Use this option define the time after which this task should be canceled automatically. The time you set here is counted from the moment this specific workflow step starts executing.

### 10.2.7. Visual Optimizations of a Workflow

Workflows can become very complex. The following tools help to visually optimize them, which will make it easier to understand them.

#### Aligning Workflow Steps on a Grid

You can align your workflow steps on a grid. To do this, hold the **Shift** key while dragging a step to the desired position. It will snap to a place on the grid.

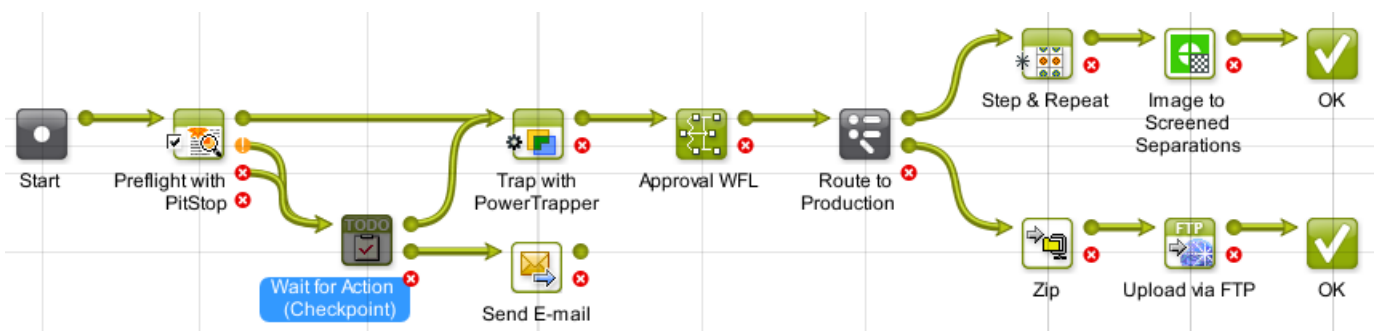

#### Hiding and Showing Transitions

To optimize the overall look and readability of a workflow, you can hide specific transitions. See this example where the transitions to one **Send E-mail** step make the workflow look more complicated than it is:

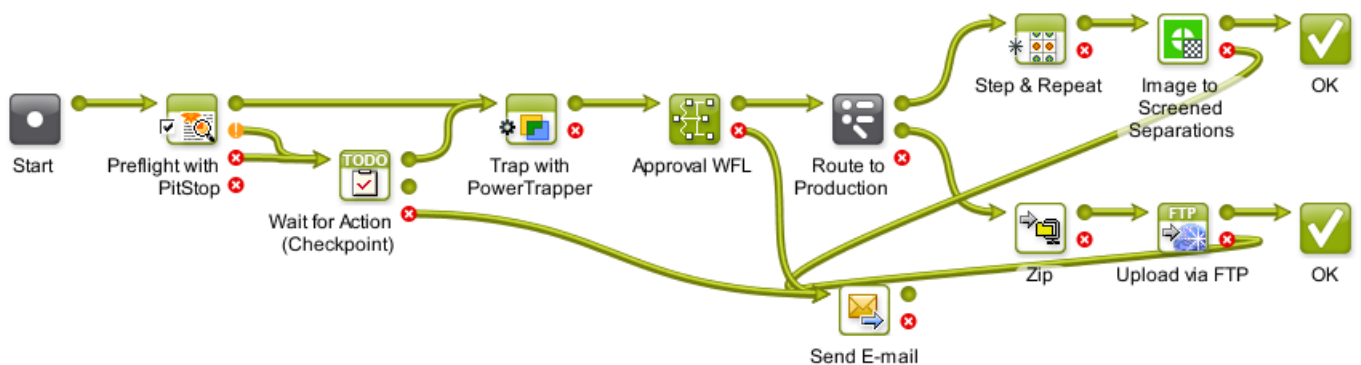

To hide the transitions to a (less important) step:

1. Right-click on the desired workflow step.
2. Click **Hide Transitions**. All transitions going to this workflow step will now be hidden. All other new transitions made to this step will automatically be hidden as well.

See this example where all transitions to the **Send E-mail** step are hidden:

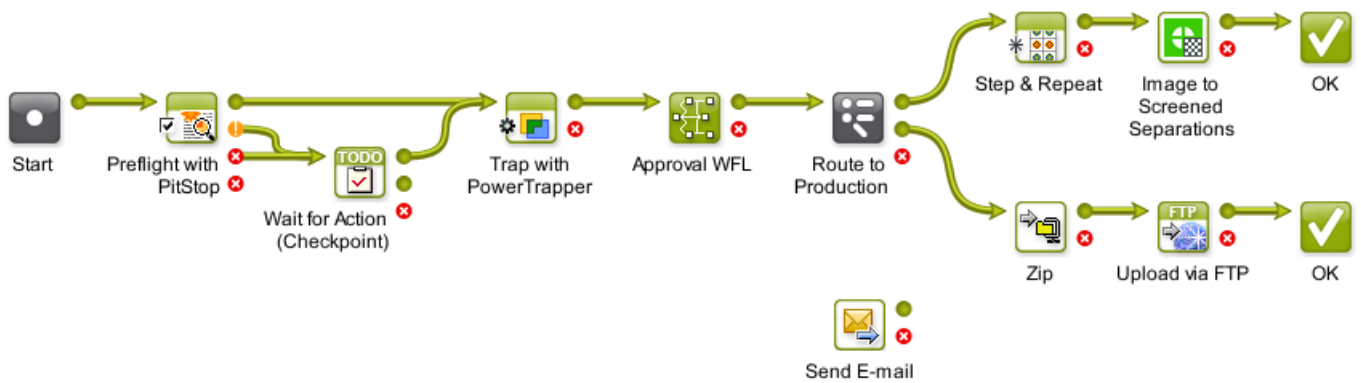

If you want to see which transitions were hidden, click on the step (start or end). The hidden transitions will be revealed in a grey color:

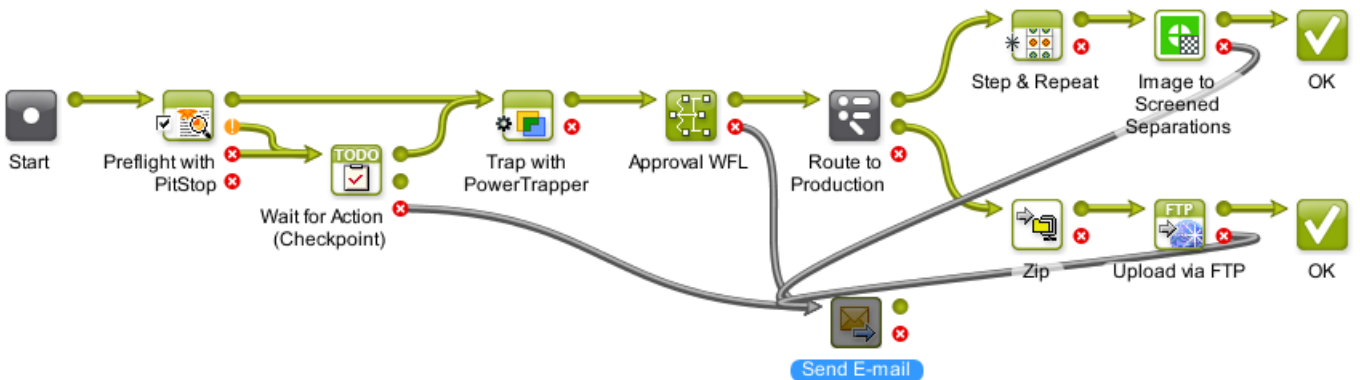

To reveal the transitions again, right-click the step and choose **Show Transitions**.

### Distributing the Space between Workflow Steps

To distribute the space between all (or selected) steps evenly and also to align them on a grid, proceed as follows:

1. Right-click anywhere in the workflow canvas.
2. To align the steps horizontally, click **Horizontal Distribute Space** or use **Ctrl + Shift + H**.
3. To align the steps vertically, click **Vertical Distribute Space** or use **Ctrl + Shift + V**.

For example, this workflow needs some realignment:

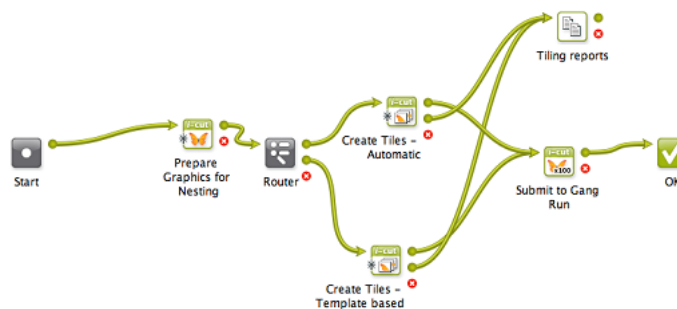

This is the result after distributing the space:

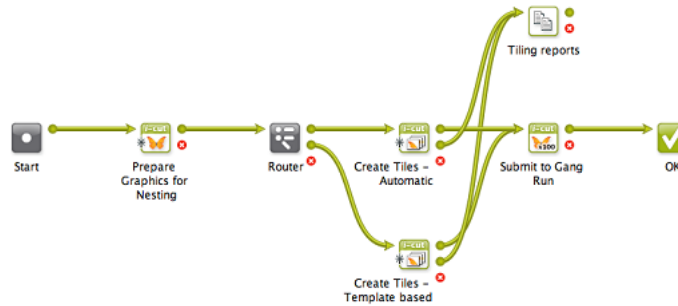

### Adding Sticky Notes

Right-click anywhere on your canvas to add a **Sticky Note** to your workflow. Use these notes to add background information and so help users understand the workflow. They can serve as warnings or to remind users why some parts are constructed that way.

An example:

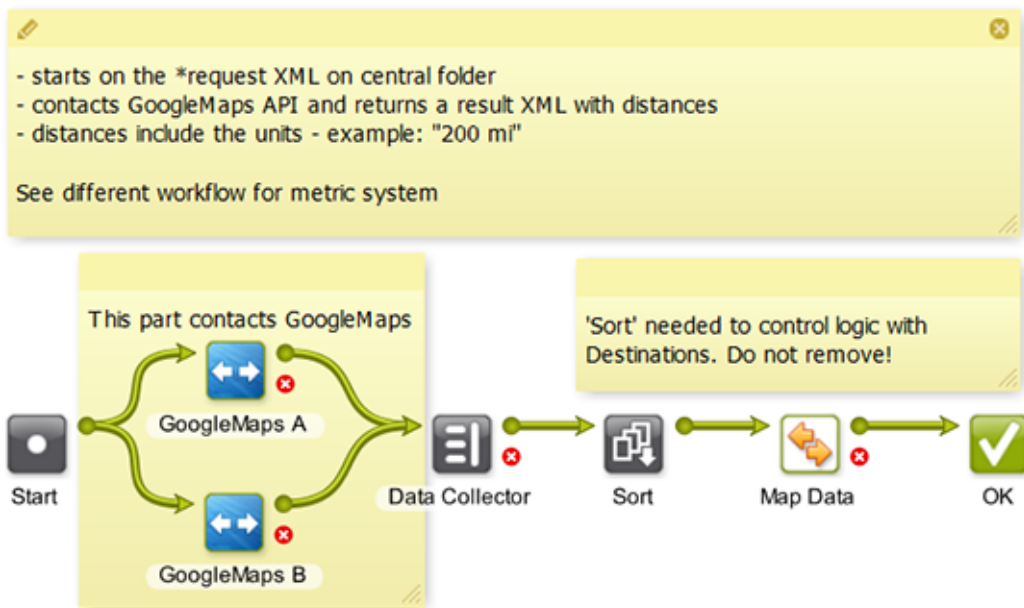

Click the icon on the top bar to choose a color:

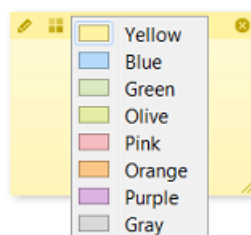





**Tip:** To move the note, click the top bar and drag it to the new location.

### Customizing the Canvas Background

You can choose a custom canvas background for all your workflows. Right-click on the canvas, choose **Change Canvas Background...** and browse to an image on your local computer.

Choose **Clear Canvas Background** to remove it again.

## 10.2.8. Subworkflows

A subworkflow is a workflow that is part of its master workflow. It is included in the workflow ticket of the master workflow. A subworkflow can also include another subworkflow. You can create workflows several levels deep.

These are two main reasons to create a subworkflow:

- The master workflow will *look less complex* when a part of its flow is represented by only 1 workflow step.
- To stop creating the same (parts of) workflows again. If you notice that you keep creating the same or similar (parts of) workflows, then consider building that recurring part once and then copying it as a subworkflow into the other workflows.

In this example we see that the complete approval workflow is represented by a subworkflow named "SUBWFL Approval":

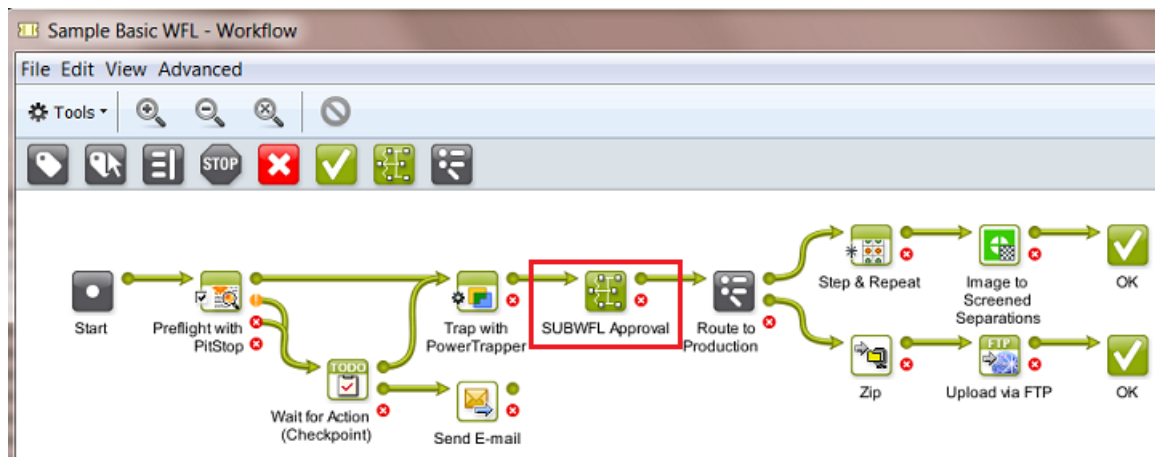

Double clicking the subworkflow step opens it in the same workflow window. Notice the indication of the path:

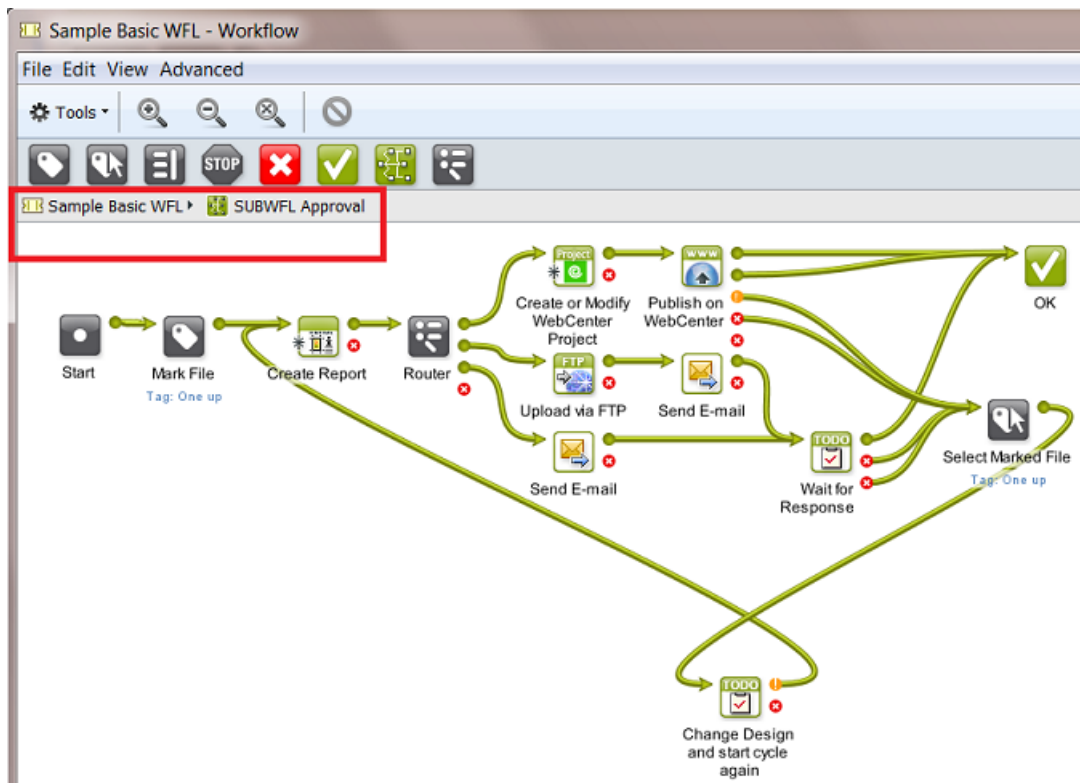

### The Difference between a Subworkflow and a Referenced Workflow

A referenced workflow is not included in the master workflow, it is not copied on board. It is a link to a separate (workflow) ticket.



**Note:** Learn about adding referenced tickets or workflows in [Building a Workflow using Custom Tickets](#) on page 741.

The advantage of a referenced workflow is that by updating your referenced workflow you so automatically update all the master workflows that refer to it. See some examples in [Good Practices for Building Workflows](#) on page 773.

See this example where the approval part of the workflow is added as a reference. Notice the small arrow and extra name of the original workflow ticket:



When you double-click a referenced workflow step, it will open in a separate window.

### Building a Subworkflow

To add a subworkflow into your workflow:

1. In the workflow editor, drag a **Workflow**  step into your workflow. Or use an existing workflow ticket ; in that case skip step 3.





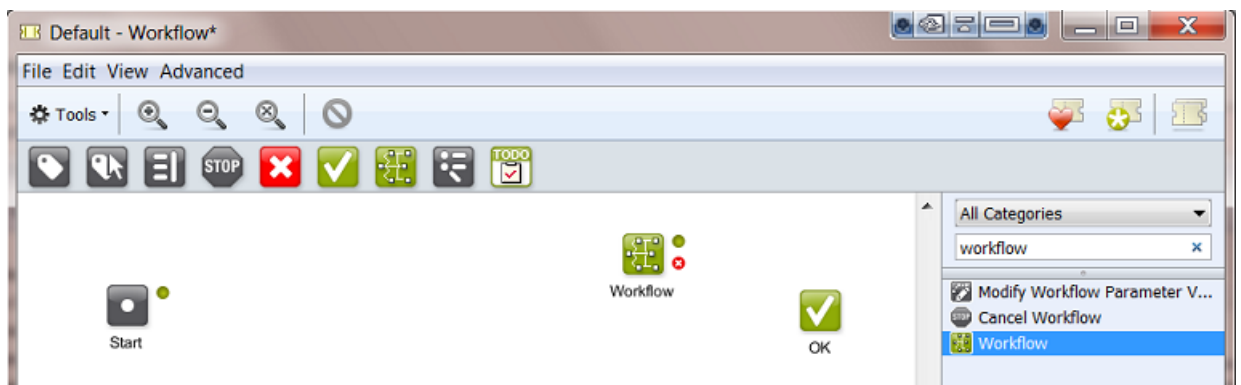

**Tip:** To find it quickly, select the category **Workflow** in the tasks pane or type 'workflow' in the search field.

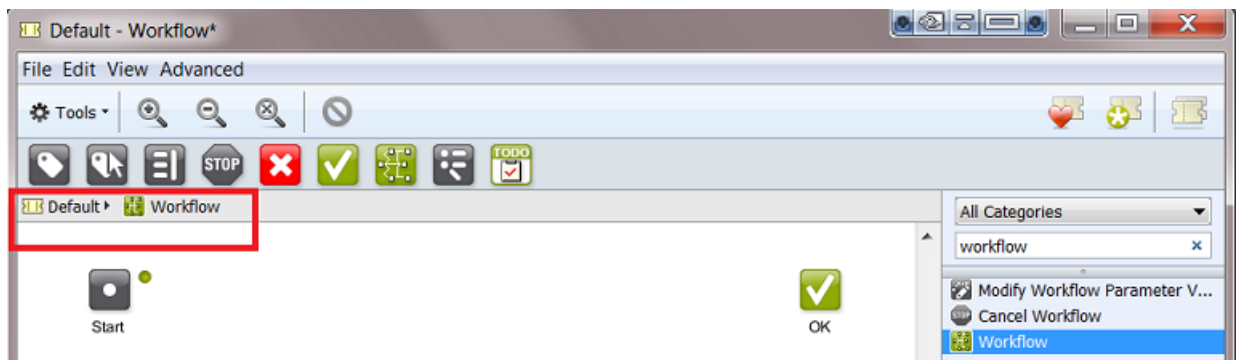

2. Double-click the workflow step.

The workflow step opens in a new canvas, where you can build your subworkflow. The extra level in the path indicates that this is a subworkflow:



**Note:** This is an example of a path indication of a workflow with 2 levels of subworkflows:  Flat Display WFL  One Up Approval  WebCenter approval

3. Build your subworkflow: Drag and drop steps into its canvas, add transitions, open each step to change its parameters. There is no need to save at this point.
4. In the workflow path, click on your master workflow to go back to it (in above example: click on  Default ▶).

- 5. Save your master workflow. Your subworkflow(s) will be saved as a part of it.

### 10.2.9. Inserting Wait Points

Sometimes you want the workflow to wait a while before continuing with the next task. There are several ways to do this:

#### The Wait Task

Use the **Wait** task in a workflow to postpone the next task to a relative or absolute time.

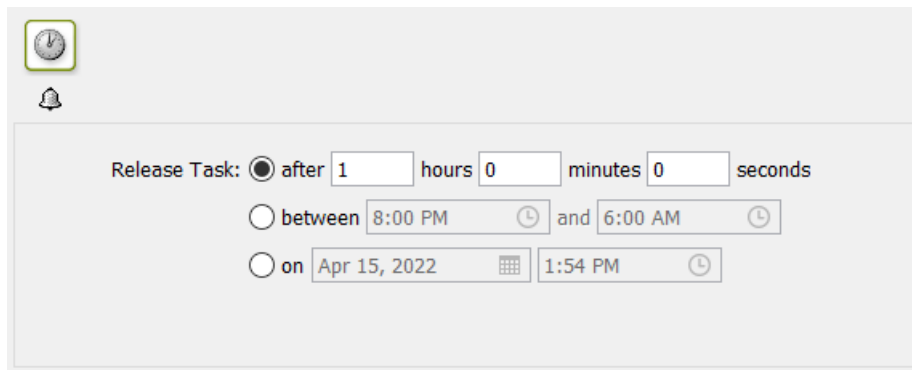

A few examples of workflows where this task is useful:

- Your workflow sends a proof to a proofing device. You want to wait 30 minutes and then send the user a *To-Do* to go and pick up the proof.



- A **Folder Access Point** launches a workflow on incoming design files. These design files have been backed up already somewhere else. That is why you can delete them from the Automation Engine Container when you are sure that the workflow no longer needs them (for example after 4 hours).



- Every night you want to clean up a specific type of files that you consider temporary. You have built this into your workflows, where a **Wait** task is set to release between 3 and 5 AM, and is followed by a **Delete** task.

#### The Wait for Files Task

Use this task when you want to process files that are not present yet.



**Note:** Instead of using this task as a step in a workflow, consider if using an *Access Point* is not a better way to wait for files (and then start a workflow on those files).

This task looks for files at a regular interval, and when it detects them, it passes them to the next workflow step.

You can define which files it should look for, how long the task should wait for them to appear and what to do if the files are not found after that time period.



**Warning:** In a workflow, this kind of type of task can put some strain on the workflow engine, especially when used a lot. So if your case can be solved by using an [Access Point](#), than we strongly advise to do so.

In any case, do not create workflows that use this task in a loop! For example: A Wait for Files task that waits for any specified period and, when it doesn't detect the files by then, the workflow then loops back to that same Wait for Files step, which then waits some more etc. Such constructions create a massive amount of [tokens](#) and this blows up the memory consumed by the workflow engine.

An example of what not to do: When the Wait for Files step was unsuccessful, a Router step does a check of the number of files in that output pin and if (for example) it is 0 or less, the workflow goes back to the same Wait for Files step. Such a setup is a guarantee for major problems with the workflow engine of your Automation Engine!

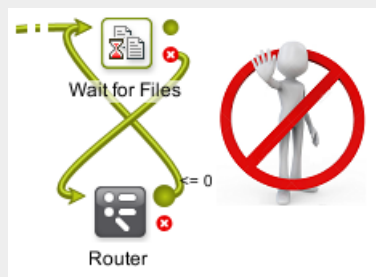

**Important:** In many cases, a better solution is to let the workflow fail and use other workflow steps or tools to continue your logic (To-Do action, notification, etc.).

1. Select the **File Type** of the file(s) you want to wait for.

You can either:

- choose to wait for **Any** file type,
- select a specific file type from the list,
- select several file types (see below).

To select one or more file types:

- a) Choose **Select File Types...** in the **File Type** list.  
This opens the **Select File Types** dialog.
- b) In this dialog, select the files types you want from the **Available File Types** column.
- c) Click  to send them to the **Selected File Types** column.
- d) Click **OK** when you are done. You will see the selected file types listed in parentheses.

2. Use the **File Name Matches** parameter to search on file names.

You can use wildcards, SmartNames or a [Regular Expression](#). You can also browse to a file with a name close to what you need, and add wildcards and/or SmartNames to that example name.

**3. Define where to look for the files in **Look in Folder**.**

Choose to **Look in subfolders** or not.

**4. Define when the task may **Stop waiting** for the specified files:**

- 1.** When a certain number of **Files** or **Pages** are collected,
- 2.** After a certain time if the files haven't been found (when **time exceeds ...**). To set a custom time, select **other...** from the dropdown list and define a custom date and time.

When you selected this option, this extra option becomes available:

- **Task ends in error when not all files were found.** Select it if you want the task to finish with an **Error** state when it has not yet detected all files at the time that you set in **Stop waiting when time exceeds ....**

Depending on what you choose, the task will finish either after it has found all the files/pages, or after a specified time if it can not detect all the files/pages.



**Note:** If you do not give the task a time limit, and it can not detect all the files, it will run indefinitely.

### The Wait for Product Status Task

This task allows to hold a workflow until one or more **Products** have reached a certain status.

This task is documented in the chapter on [Products](#) on page 594. Find a direct link [here](#).

### The Wait for Action (Checkpoint) Task

#### Concept

Use this task to hold your automated workflow for any form of user intervention.

This task adds a **'Wait for Action'** item in the [To Do List](#).

When a user checks and completes that required action, he 'releases' that item back to the workflow. He can choose to let the workflow continue, to abort it or to have it take another route in the rest of the workflow.

#### Tab 'Message'

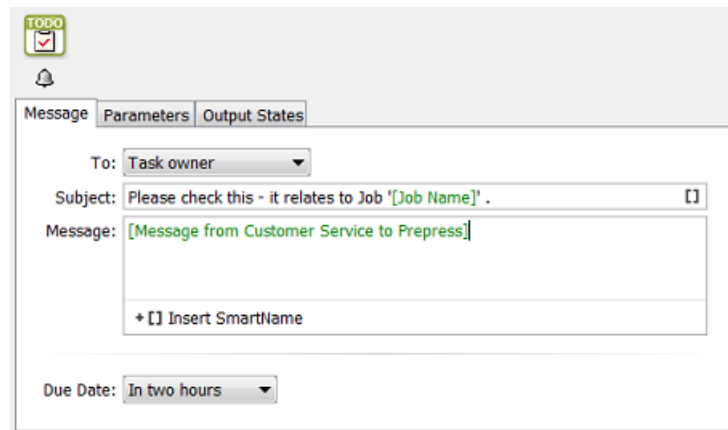

You here define what you want to communicate to which user.

- **To:** From the drop-down list, choose a specific user or the **Task owner** (the user who launched the task) or choose **any user** (all users then get the to-do item in their list).

If you use a SmartName to specify the user, make sure it resolves to the method "name@domain" (for example "franky@aeserver01" or "franky@fruitco-domain").



**Note:** Also the choices **any user** and **Task owner** can also be accessed through a SmartName. This SmartName needs to resolve to their internal **Parameter Value** "Task Owner...@" and "Any User...@". Learn more about this in [SmartNames of Parameter Values](#) on page 729.

- **Subject:** This subject line is shown in the To Do List overview.
- **Message:** Optionally, add extra information.
- **Due Date:** Setting a due date becomes useful when you want to sort of create filters in the To Do List overview (learn more in [The To Do List View](#) on page 118). Choose from the drop-down list to set a relative or an absolute time ('On').

## Tab 'Parameters'

### Concept

A to-do item that was created by the **Wait for Action** task can be extended with additional parameters. There are 3 types of parameters that you can add:

- **Workflow Parameters** make it possible to change the value of a workflow parameter in a to-do item. Learn more [here](#).
- **Info** parameters make it possible to show extra information in a structured way (name, value). Learn more [here](#).
- **Link** parameters allow to add hyperlinks to the to-do item. These can be links to an external web site, an E-mail address or even a task in the Tasks view. Learn more [here](#).

You can add several parameters of several types.

The order in which you add them in this tab is the order in which they will appear in the to-do item. To change this order, simply 'drag-and-drop' the parameter up or down.

**Adding a Workflow Parameter to a To-Do**

**Settings**



**Note:** Find some examples below.

- Click **Add**. The **Edit Parameter** dialog opens.
- **Type:** Select **Workflow Parameter**. Learn all about workflow parameters [here](#).
- **Workflow Parameter:** The name of the existing workflow parameter that you allow to be changed in this to-do.

Type in the name or click to pick it from a list.

If the workflow parameter does not exist yet, you will be informed about this when closing this 'Edit Parameter' dialog. That message will allow you to create it or not (yet).

- **Style:** How should this workflow parameter be presented in the to-do item?
  - As a **Text Field:** Fill in any text as the value for this workflow parameter.
    - **Placeholder Text:** This text is shown in the text field when the value of the workflow parameter is still empty.
  - As a **Combo Box:** The parameter is presented in the to-do as a combo box. The user, after clicking Edit, can pick a value from a list of predefined values.
    - **Placeholder Text:** This text is shown and selected in the combo box when the value of the workflow parameter is still empty.
    - **Values:** A comma separated list of values. Do not use spaces. These are the values from which the user can choose.



**Note:** A running workflow can decide another value than those in this list. When the value of the workflow parameter is not present in the list of values, and the value is not empty, the value will be added to the combo box and will be shown and selected in the to-do item.

- As a **Checkbox:** The parameter is presented in the to-do item as a checkbox. The user, after clicking Edit, can either select or deselect the checkbox.
  - **Checkbox Text:** The text that will be displayed to the right of the checkbox.
  - **Unselected Value:** The value that will be given to the workflow parameter when the checkbox is not selected.
  - **Selected Value:** The value that will be given to the workflow parameter when the checkbox is selected.



**Note:** In case the value of the workflow parameter is not equal to the unselected value nor to the selected value, then the value will be set to the unselected value.

- **Label:** In the to-do item, this text will appear in front of the parameter.
- **Info Text:** In the dialog **Edit Workflow Parameter**, this extra text can help to clarify this parameter or its effect.



**Some Examples**

- Using a **Text Field**:

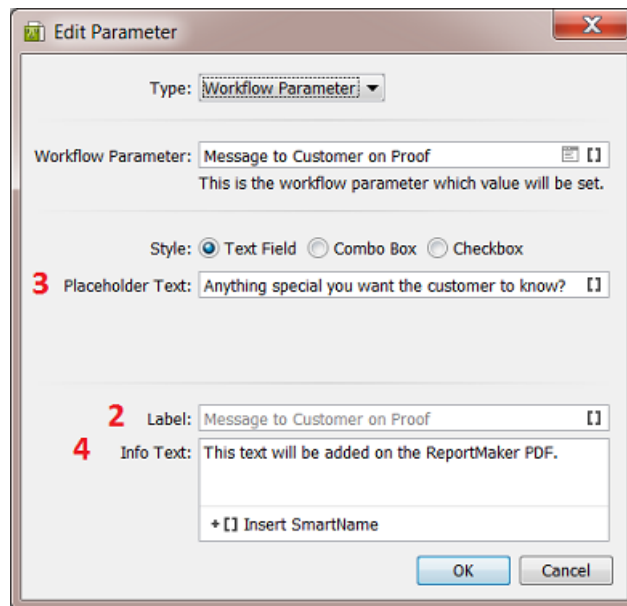

Resulting to-do item:

1. = **Info and Workflow Parameters**: An extra area in the to-do dialog where these extra parameters appear.
2. = **Label**
3. = **Placeholder Text**
4. = **Info Text**

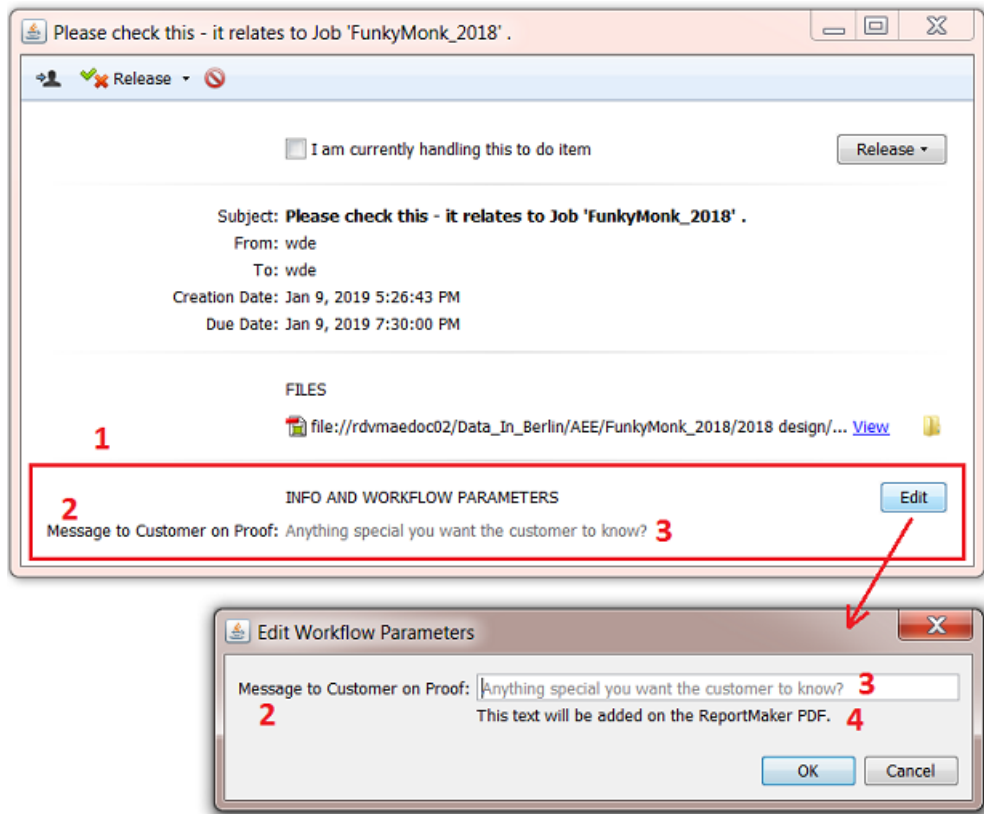

**Attention:** Notice how the user needs to click **Edit** to change a value.

- Using a **Combo Box**:

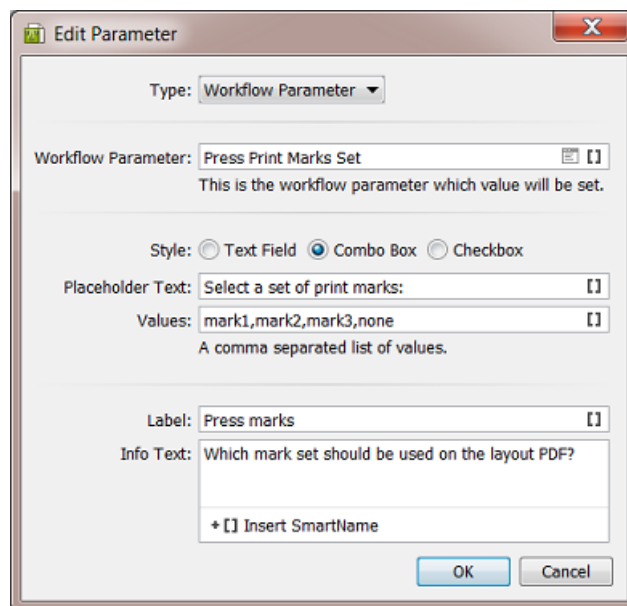

Resulting to-do:

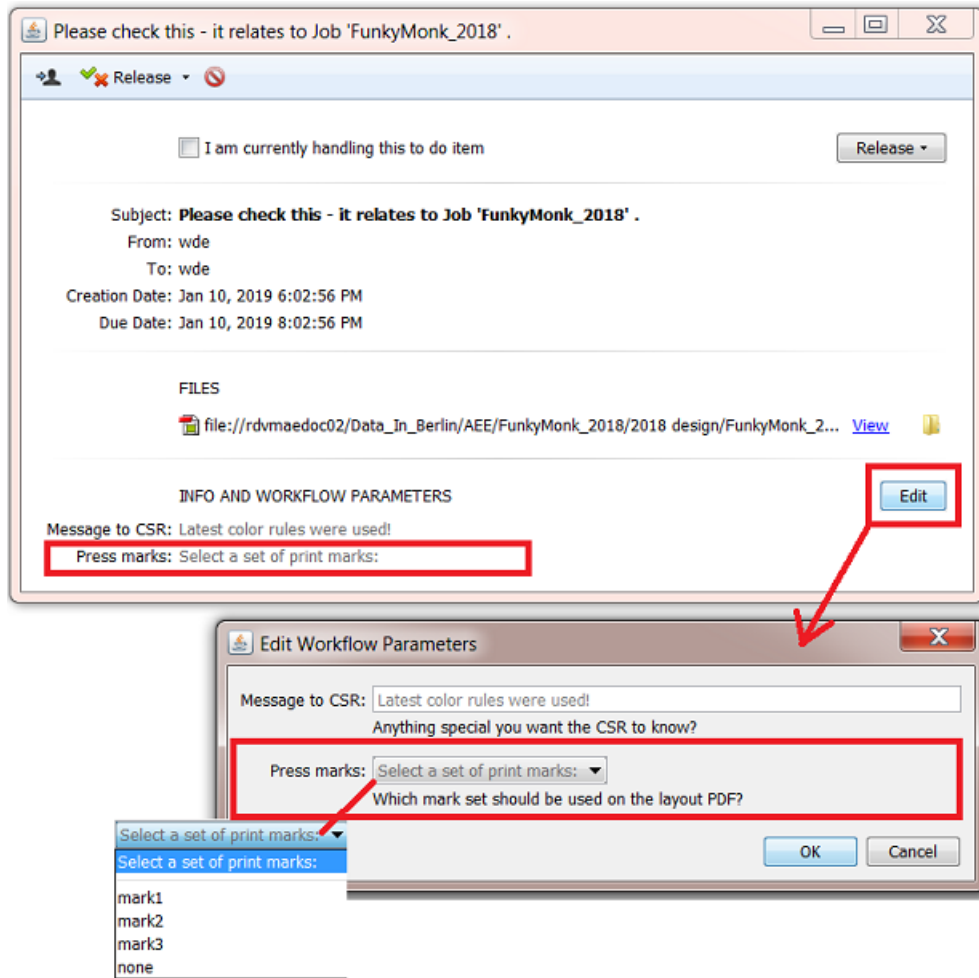

- Using a **Checkbox**:

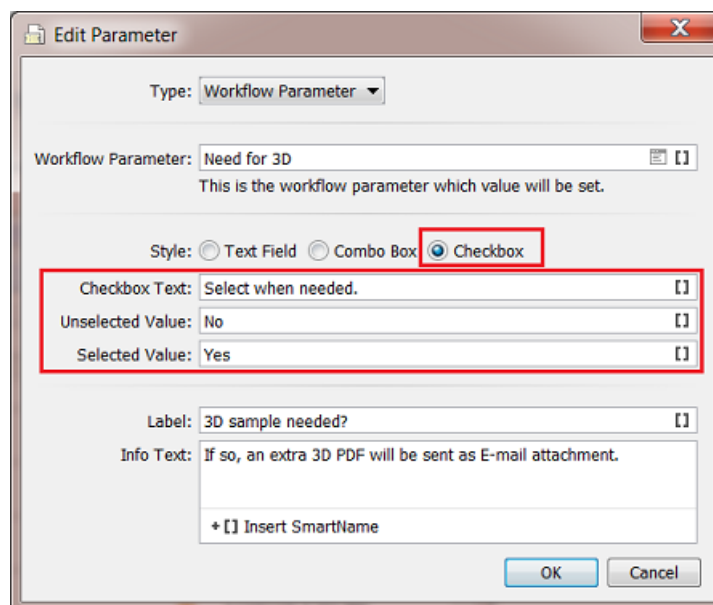

Resulting to-do:

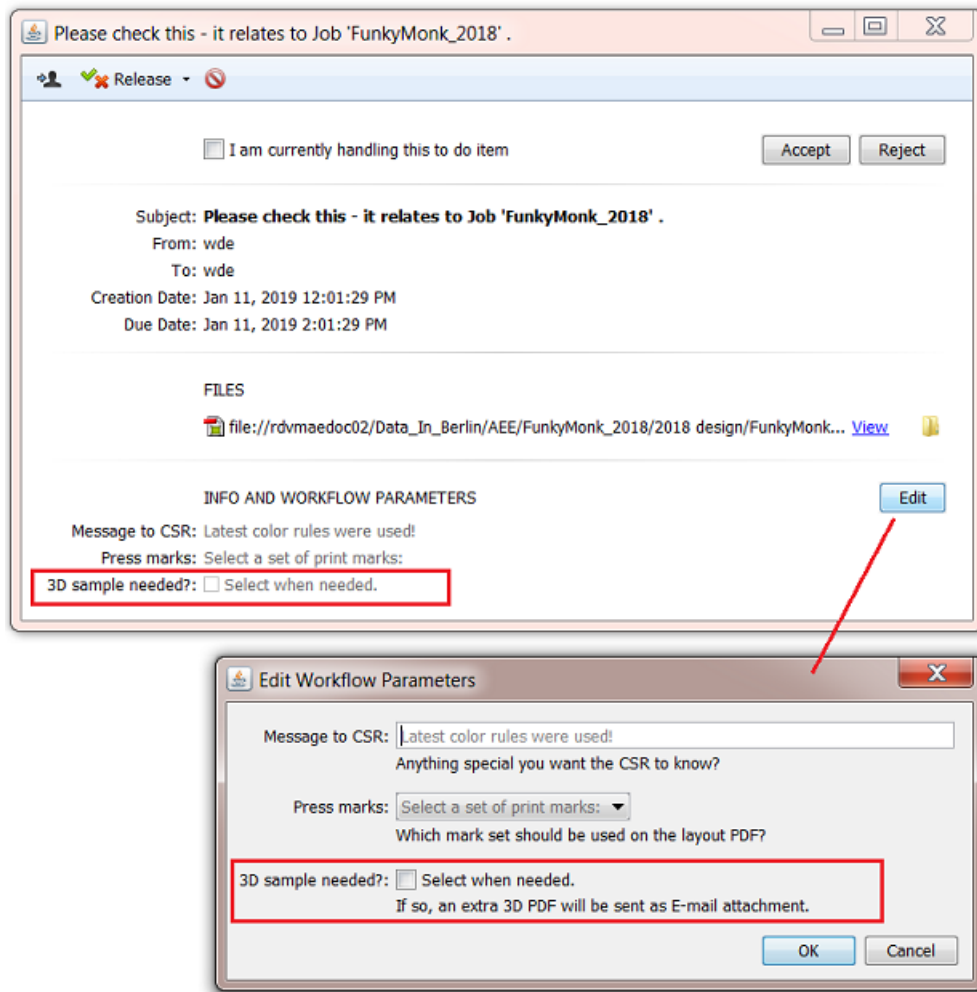

**Adding extra Info to a To-Do**

**Settings**

- **Info:** The value of the to-do parameter.
- **Label:** The text that will appear in front of the to-do parameter.



**Note:** Contrary to workflow parameters, this information is read-only ; the value can not be edited in the to-do item.

**Example**

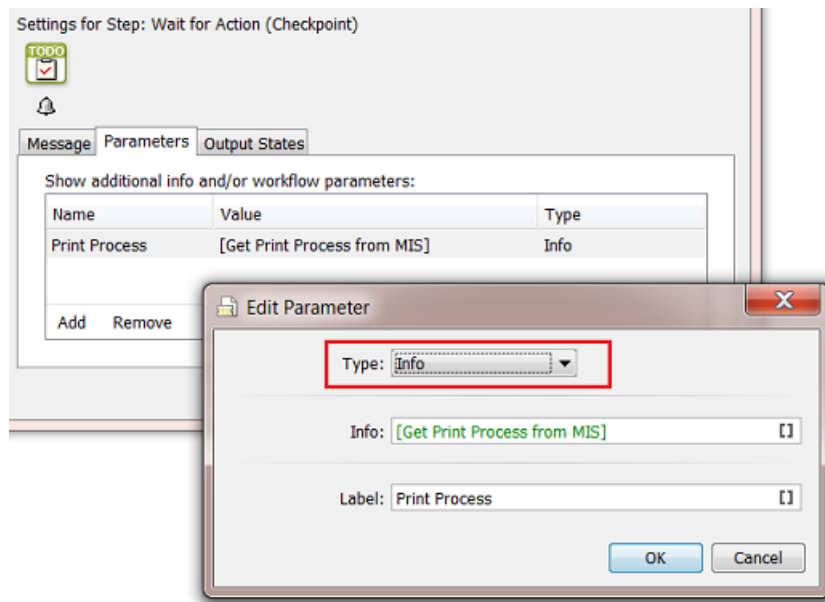

Resulting to-do:

When the value that the SmartName retrieved from the MIS is 'Flexo 6col':

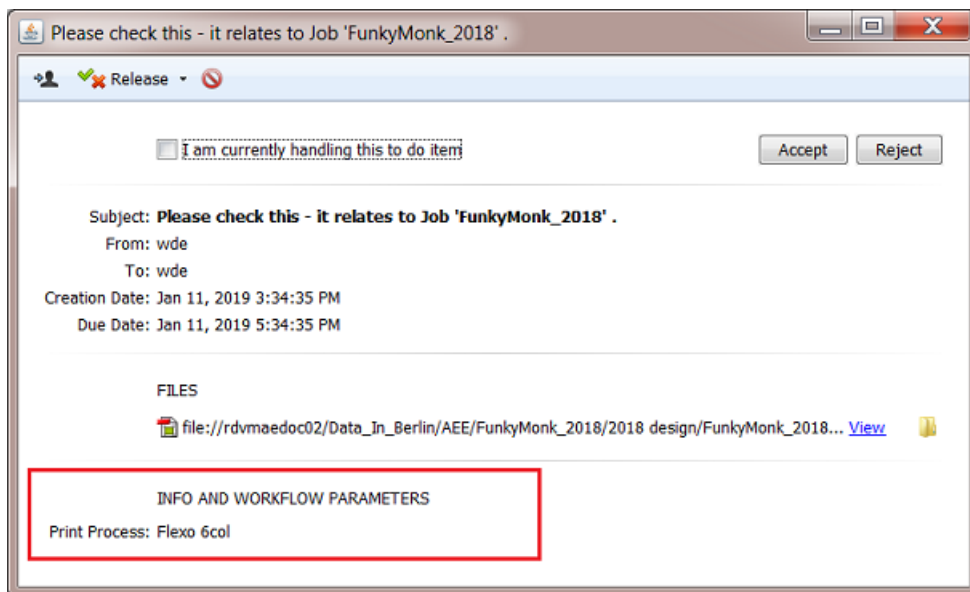

### Adding a Link to a To-Do

#### Settings

- Click **Add**. The **Edit Parameter** dialog opens.
- **Link Type**: The type of hyperlink.
  - **External Link**: Fill in the URL in the **URL** field. This can be a hyperlink to an external website (example: <https://www.esko.com>) or to an *E-mail link* (example: <mailto:someone@example.com>).



**Note:** The scheme `http://` or `https://` is mandatory for the URL to be correct. `www.esko.com` is not a valid URL. The URL also needs to be *URL encoded*.

- **Task Link:** This is a link to a (finished) Automation Engine task. The value needs to be the **Task ID (internal)** of that task (learn below how to retrieve that value). In the to-do item, when you then click on such a link, the task with that internal ID will be selected in the Tasks view. See an example below.
- **Link Text:** It is possible to specify a text that will be shown in stead of the actual hyperlink. When you leave this empty, the URL will be shown in the hyperlink.
- **Label:** This is the text that, in the to-do item, will appear in front of the link.

### Example of a Task Link

Some automated tasks are not monitored by users, and nobody notices when they go wrong. To alert the users and make them analyse why this specific task had a problem, you can add the following settings to that automated workflow:

In this example, we want to make sure we are aware when something goes wrong with the 'Create Job' step in our workflow. This workflow could for example be triggered by a business system or be started by Esko Cloud.

1. When that step ends in error (or warning), redirect the workflow to these 2 extra steps:

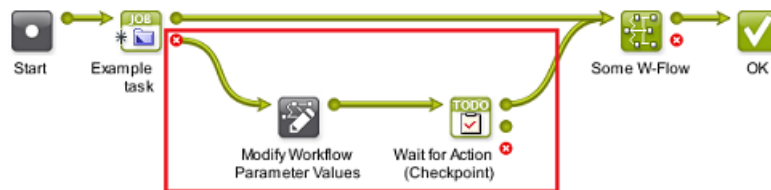

2. In the workflow editor, go to **Advanced > Manage Workflow Parameter**, **Add** a workflow parameter and **Name** it "Task ID from Previous task". Leave the **Value** empty and click **OK** and close the dialog.

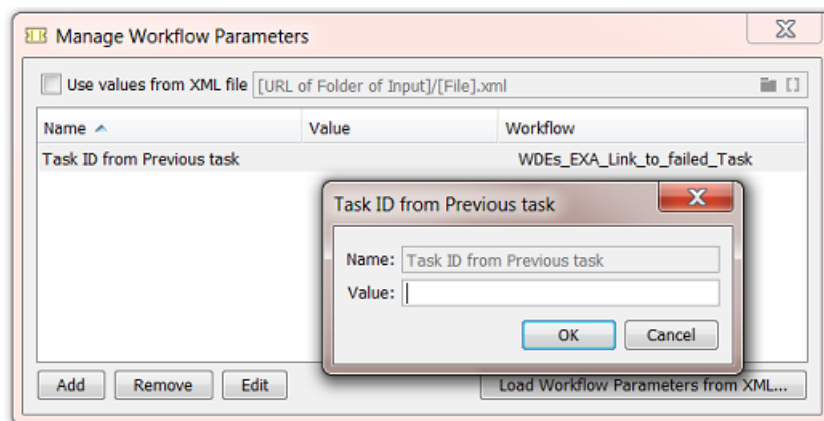

3. Open the ticket of the step **Manage Workflow Parameter Values**. Click **Add** and click to select the workflow parameter you just created. Set the **New Value** of this parameter to the SmartName **Task ID (Internal)**. This will pick up the internal ID of the previous task in the workflow, in our example the 'Create Job' task. Click **Add** and **OK**.

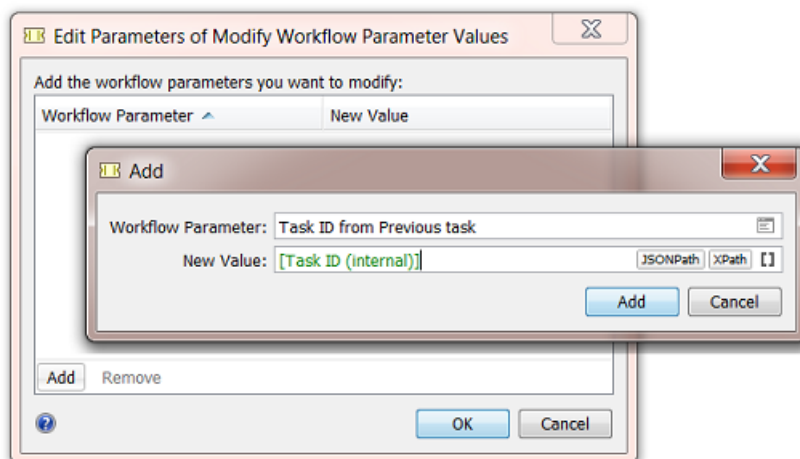
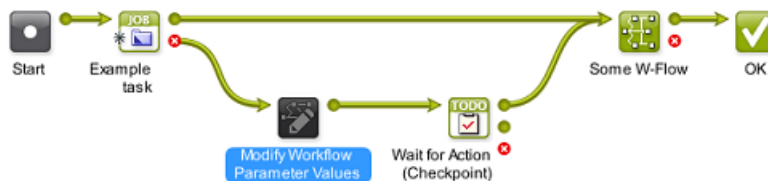

4. Open the ticket of the step **Wait for Action (Checkpoint)**.

- In the tab **Message**, add the **subject** "Check why the previous task failed".
- In the tab **Parameters**, click **Add** and select
  - **Type: Link** and **Link Type: Task Link**.
  - **Task ID (internal)**: Open the list of SmartNames. Select the category 'workflow parameters', select the one you made earlier and click **Insert**:

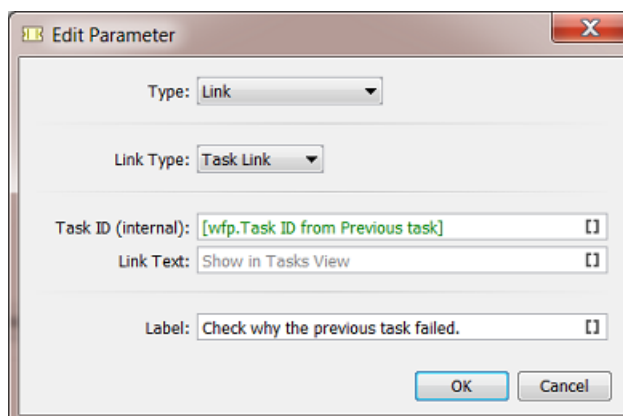

- **Link Text**: In our example, we leave the default text that will appear as the text that the user will need to click on ("**Show in Tasks View**").
- **Label**: Type 'Check why the previous task failed'.

- Click **OK**, **OK** and select **File > Save** to save the workflow ticket (or choose **Save As...** and save it as **Favorite**).



**Note:** In this workflow, we did not edit the step **'Create Job'**. This is fine because we want to have that step end with an error anyway.

- In the Pilot, in **Files** view, choose the **Containers** mode, select any input file or folder and launch this workflow.
- You should quickly see that the step 'Create Job' failed and that a to-do item was created.
- Go to the **To Do List** view, select or open the item that was just created:

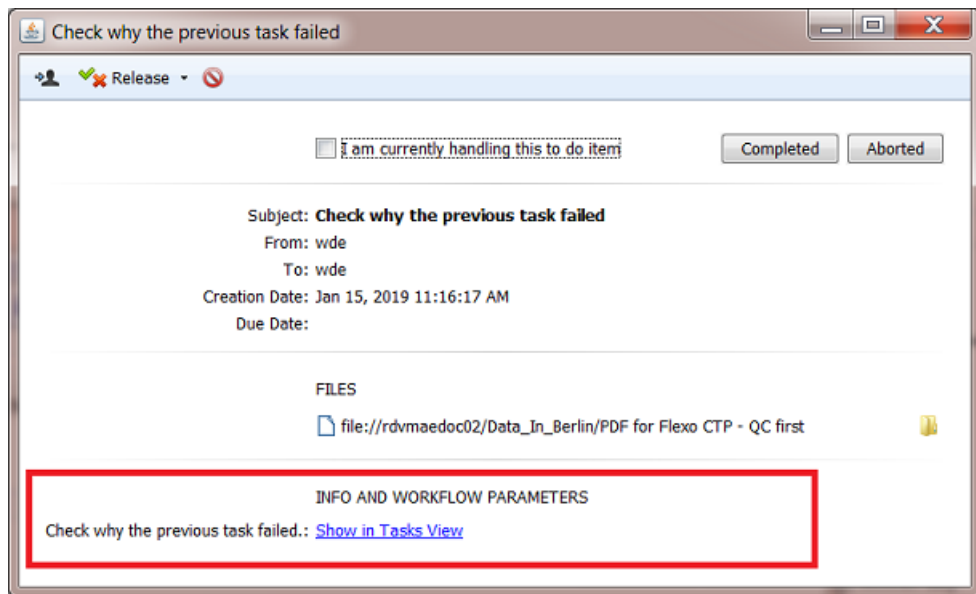

- Click on the blue hyperlink. It should open the **Tasks view** and have the task selected that failed. The task's **Details** or **Log** file will mention what the problem was.

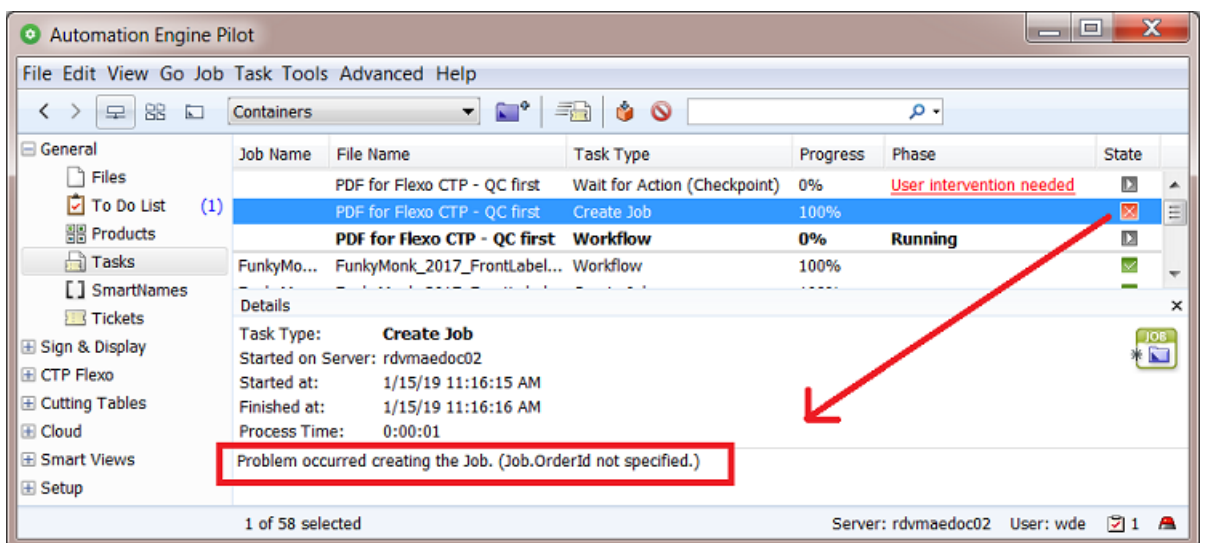





**Tip:** When you right-click a [token](#), you can ask to see the value of the workflow parameters at that point in the workflow. In our example, this visualises the internal ID that we used to find that task.

The screenshot shows a workflow diagram with several tasks: Start, Example task, Modify Workflow Parameter Values, Wait for Action (Checkpoint), User intervention needed, Some W-Flow, and OK. A context menu is open over the 'Wait for Action (Checkpoint)' task. The menu items are: Open..., Open With, View..., Relaunch, Show in Files View, Show in Tasks View, Open Task..., Open Log..., Open Details..., and Workflow Parameter Values... (highlighted with a red box and a red arrow). Below the menu, a 'Workflow Parameter Values' window is visible, containing a table with the following data:

Name	Value
Task ID from Previous task	15c3ff1d-b11e-4e35-821e-287c436



**Tip:** In the to-do item, hover your mouse over the hyperlink to see what it resolves to:

The screenshot shows a dialog box titled 'INFO AND WORKFLOW PARAMETERS'. It contains the text 'Check why the previous task failed.: [Show in Tasks View](#)'. A tooltip is visible over the hyperlink, showing the URL 'ae:task?id=15c3ff1d-b11e-4e35-821e-287c436a109d'.

**Tab 'Output States'**

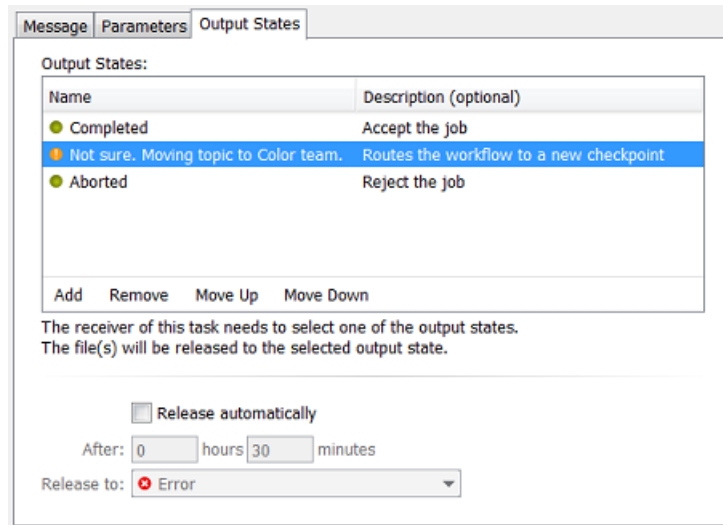

- **Output States:** You here define in what state this to-do item can be released. In a workflow, these output states are shown as output 'pins' with that (custom) name.
- Click **Add** to add a new output state. Enter a **Name** and **Description** (optional) for the output state.
- Choose the **Type** from the list of symbols.



**Note:** When this task is used as a step in a workflow, the **Type** only defines the small icon that will be used for the output pin. The state of the workflow only depends on which next step in the workflow that that output pin links to.

For example: When choosing a (red) 'Error' symbol for a state that you named 'Not OK', then this does not yet mean that the workflow ends in error.

- Whatever the type of output pin (green, orange, red), it can be linked to any next step in the workflow, possibly a specific branch for that state.
  - When there is no next step, then indeed the workflow will end with the same state as the one you choose here.
- **Show workflow parameters dialog.** When selected, clicking the button of an output status in the to-do message will first open this dialog. This allows you to add comments or make changes to these parameters before that chosen output state is confirmed. See an example below.
  - **Release automatically:** Select this if you want the task to end after a specific time to a specific state.

### Example of Output States that first Ask for More Info

1. Add the workflow parameters to the workflow ticket that contains the 'Wait for Action' step.

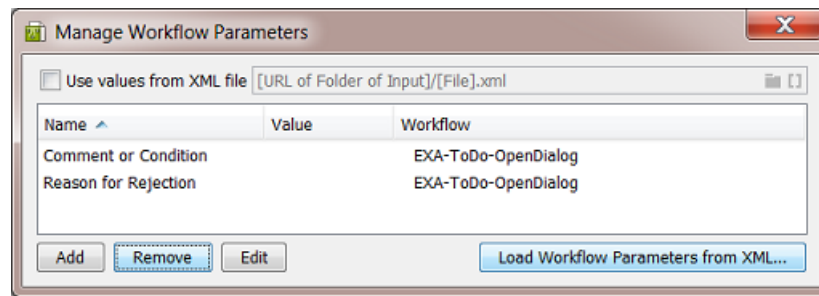

2. In the **Wait for Action (Checkpoint)** step, they appear in the tab **Parameters**:

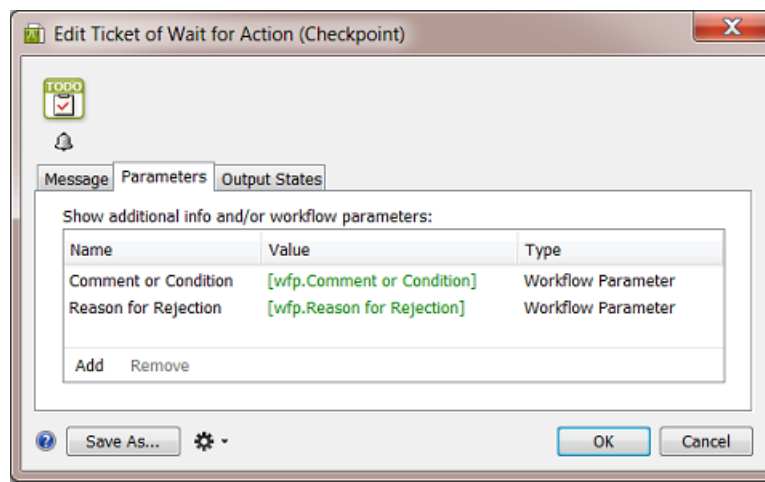

3. The next tab **Output States** is where we define how a user can decide how to end the resulting to-do action. Here are the 3 states we added and their settings:

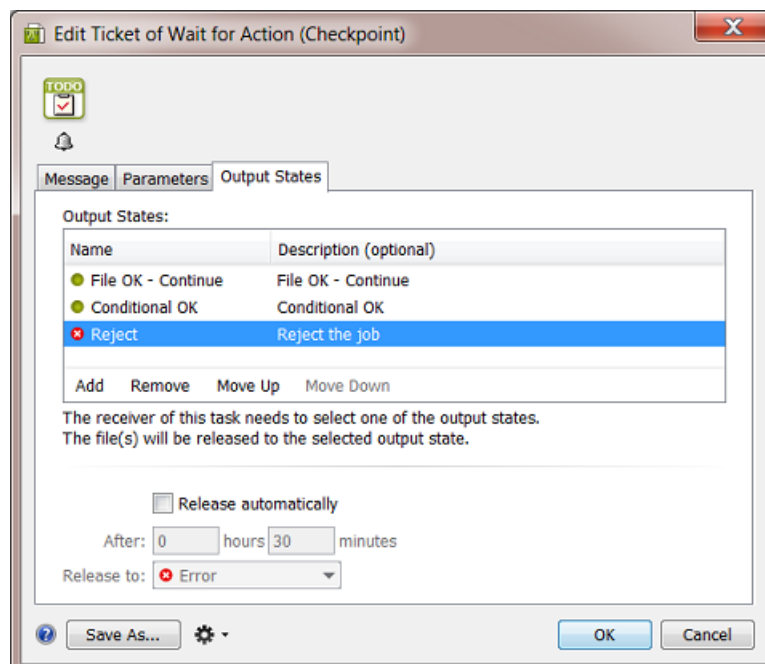

- a. The output state 'File OK - Continue':

When a user clicks this button, the to-do action will end and close.

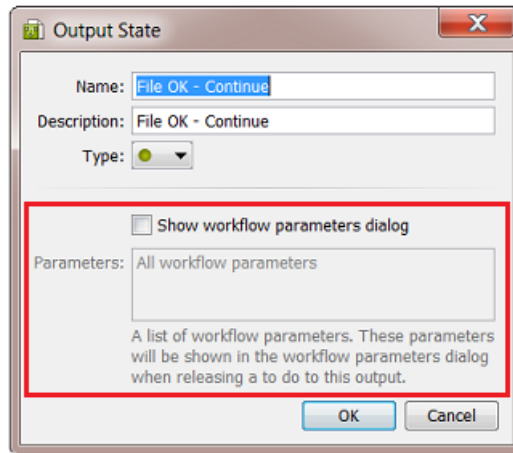

- b. The output state 'Conditional OK':

- **Show workflow parameters dialog** is selected.
- When the field **Parameters** is left empty, all workflow parameters will be presented. When you select one, as was done here, only that one will be shown.

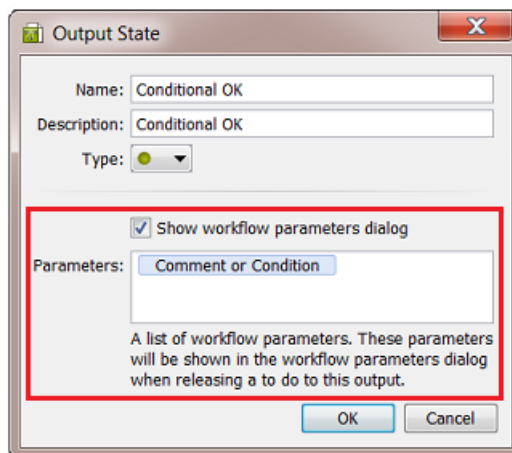

- c. The output state 'Reject':

- **Show workflow parameters dialog** is selected.
- Again, only one parameter was selected: again only the one that is relevant to the choice of rejecting the file.

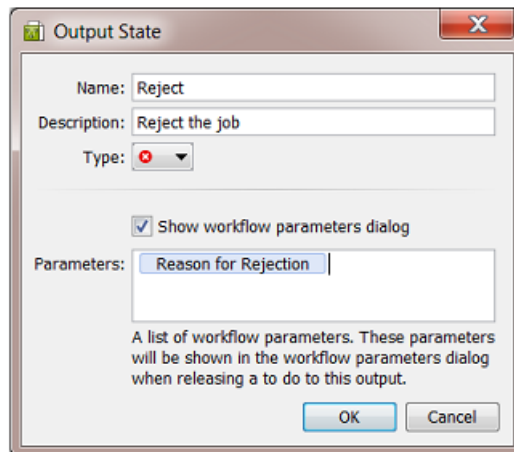

4. As a result, when the workflow runs the step 'Wait for Action', this is how the to-do action will present itself:

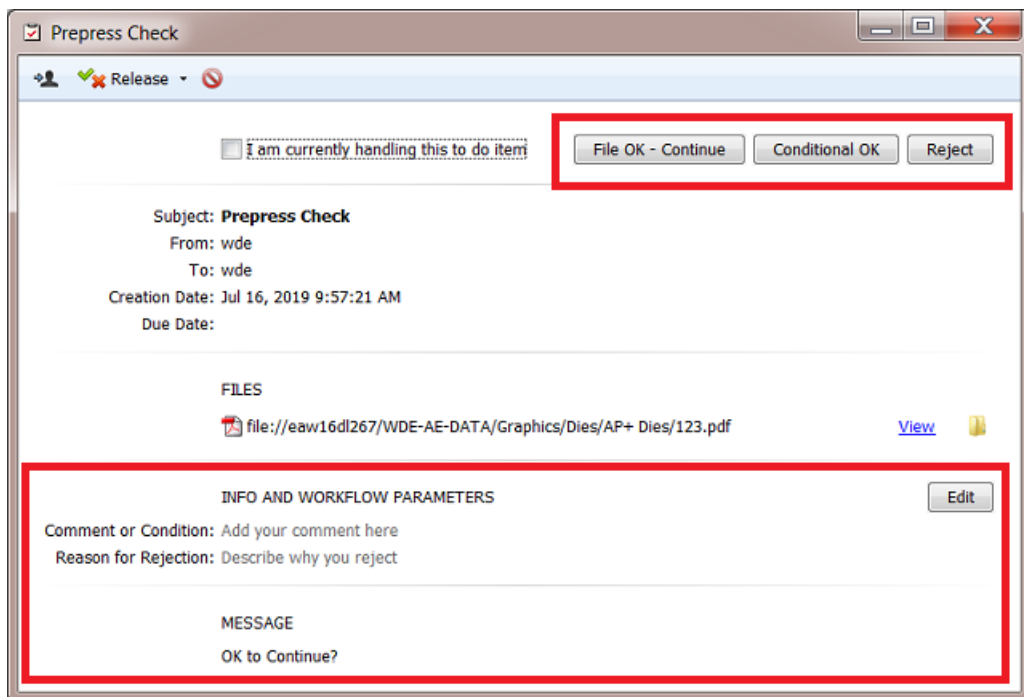

5. You can at any point click the button **Edit** and see or edit the provided parameters. But in this case we configured the decision buttons on top so that we don't need to click **Edit** any more.
6. When the user clicks ...
  - 'File OK - Continue', the to-do action is released with this state and the dialog closes.
  - 'Conditional OK', the dialog opens that allows us to edit the workflow parameters. We only see the parameter that was chosen. Add a comment and click **Release** this to-do action to this output state.

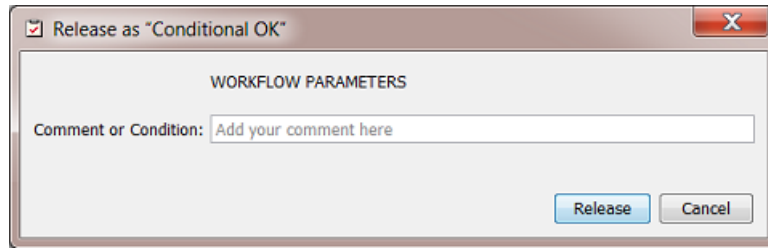

- 'Reject', the same dialog opens, now with the other parameter that is relevant to this output state.

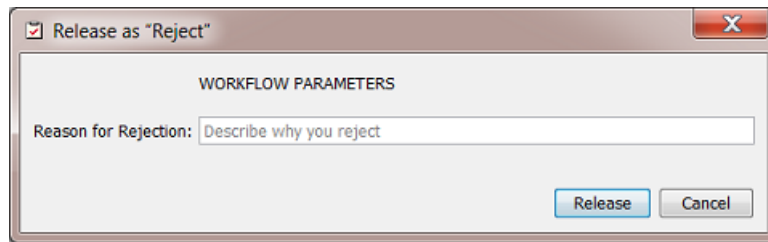

### Using the To Do List to Distribute Work

#### Example of a Workflow combining a To-Do for "Any user" with one for "Task Owner"

It is possible to use the To Do List to distribute tasks. The first user who picks up a to-do action can become the owner of the rest of the workflow.

See this example of a workflow that is launched by a **Folder Access Point**: the first Checkpoint task sends the to-do to **Any User**. The second Checkpoint task sends it to the **Task Owner**:



The Folder Access Point launches this workflow with a non-specified user:

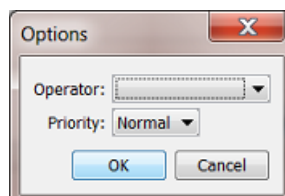

Learn more about Access Points in [Access Points](#) on page 1777.

This is how the result looks like in the Tasks view:



Tasks						
File Name	Task Type	Progress	Phase	State	Launched	Operator
banana.pdf	Wait for Action (Checkpoint)	0%	User intervention needed	⚠	10/30/14 4:24 PM	wde@rdvmaedemo
banana.pdf	Wait	100%		✓	10/30/14 4:23 PM	wde@rdvmaedemo
banana.pdf	Wait for Action (Checkpoint)	100%		✓	10/30/14 4:20 PM	UPLC@RDVMAEDEMO
<b>banana.pdf</b>	<b>Workflow</b>	<b>0%</b>	<b>Running</b>	⚠	<b>10/30/14 4:20 PM</b>	<b>UPLC@RDVMAEDEMO</b>

- At first, the user was "UPLC" (the system user when no user is specified in an Access Point).
- The first to-do became visible in the list of All users.
- This first to-do was handled by the user "wde", which made him/her the Task Owner from that point on in the workflow.
- The second to-do goes to the Task Owner, which is still "wde".

## 10.2.10. Routing in Workflows

### Simple Processing Routing

As mentioned in *Building a Workflow from Scratch*, transitions can route your files to different workflow steps. Automation Engine will automatically check the format of the files going through this step, and send them to the appropriate step(s) for that file format.

See this example where the PDF will go to the trapping step:

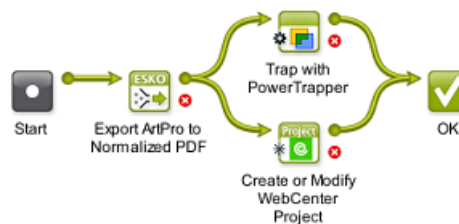

However, to keep an easier visual overview of your workflow, we advise to use a Router workflow control instead (learn more in *Automatic Routing* on page 772).

### Routing in Subworkflows

When a subworkflow has multiple end steps, an extra type of routing becomes possible. The end steps of your subworkflow correspond with the outputs of their workflow step in your master workflow.

For example, this subworkflow ends with two 'OK' end steps that were renamed to "Small Press" and "Big Press".

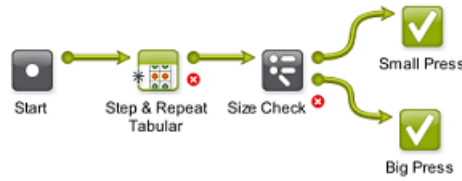

In the master workflow, you can see that they correspond to the two green output pins of the subworkflow step "Layout".

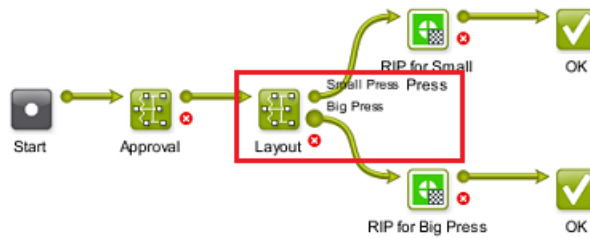

This means that:

- files sent to the "Small Press" end of your subworkflow will go through the "Small Press" output pin in your master workflow,
- files sent to the "Big Press" end of your subworkflow will go through the "Big Press" output pin in your master workflow.





### Routing via To Do List Action Items

Users can decide the route of the workflow (files) through **Action** items in their **To Do List**. They can also choose to forward the to-do action item to another Automation Engine user.

Learn more about Workflows creating Actions in a user's To Do List in [The Wait for Action \(Checkpoint\) Task](#) on page 752. Learn more about using the To Do List in [The To Do List View](#) on page 118.

### In the Pilot Tasks View

In the Tasks view, the **Wait for Action (Checkpoint)** task shows the **Phase "User intervention needed"**. Below right, the icon  shows that one (extra) item is added to this user's To Do List.

Job Name	File Name	Task Type	Progress	Phase	State	Launched
ta_shu_Plugin_Set...		Wait for Action (Checkp...	0%	User intervention needed		11/02/10 10:43
ta_shu_Plugin_Set...		Trap - Prepare and Cre...	100%			11/02/10 10:43
ta_shu_Plugin_Set...		Normalize PostScript / P...	100%			11/02/10 10:42
ta_shu_Plugin_S...		Workflow	0%	Running		11/02/10 10:42

You can click either of these elements to **Release** the item to one of the outputs that were defined in the **Wait for Action (Checkpoint)** task. This will close the To Do item.



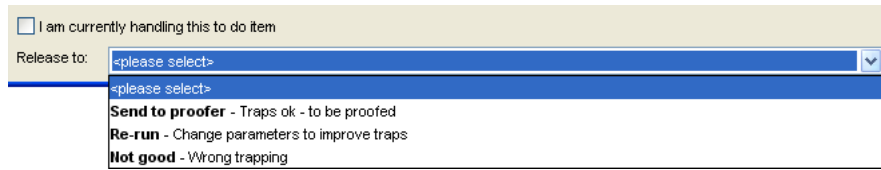

**In the Workflow Editor**

In the workflow editor, the user will see **User intervention needed** as the file status and the **Checkpoint** task step will jump up and down:



The workflow editor will also show one to-do  (for this workflow).

To route (and close) the to-do item, you can

- right-click the file icon and select one of the outputs defined in the **Checkpoint** task.

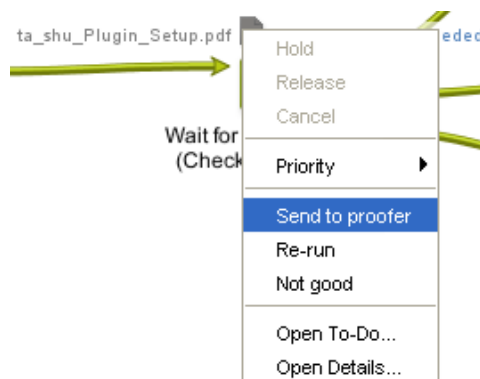

- right-click the file icon and select **Open To-Do...** and there select one of the outputs offered in the **Release** button
- click the To Do List icon  to open the item in the To Do List and there select one of the outputs.



**Note:** In the To Do List, make sure the **Actions Filter** shows the **Wait for Action** items.

**In Shuttle**

In the client application **Shuttle**, Checkpoint tasks and To Dos can be handled in the same way as you do [in the Pilot Tasks View](#).



**Attention:** The user name you used in the **Checkpoint** task and the user name used in Shuttle to connect to Automation Engine must match.



**Note:** Learn more about Shuttle in [Working with Shuttle](#) on page 875.

### Automatic Routing



The **Router** workflow control enables a workflow to automatically decide the route that your workflow (files) should follow.

The criteria that you define to route to a specific output Pin can be based on many different types: the file type, the number of separations, the value of a Job Parameter, etc.

For example: routing files based on their **File Type**:

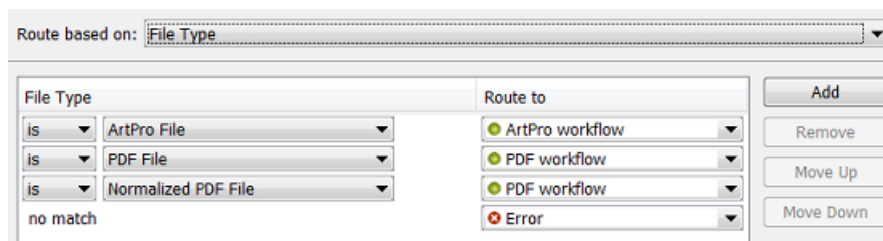

... and so send each file type to an appropriate next task in the workflow:



In the above example, ArtPro files are routed to their own normalization task, while Native or Normalized PDF files are sent directly to the Trap task.

Learn more about the Router in [Router](#) on page 811.

## 10.2.11. Exchanging Workflows

The two main reasons to export and import workflows are

- to exchange them with other plants of your company that also use Automation Engine.
- to exchange them with Esko Customer Service.

Exchanging workflow tickets is done *in the same way as for single tickets*:

1. **Export** the workflow to a ZIP file (in Tickets view or in the Workflow Editor).
2. Send the ZIP file to the other Automation Engine (onto a client computer of that server).

- At the receiving site, in Pilot Tickets View, select **Import**, browse to the ZIP file, and click **OK**.



**Attention:** The Automation Engine software version on the server that imports the ZIP may not be on an older version than the Automation Engine server that created the ZIP.

### What about references?

As mentioned in [Functionality in the Tickets view](#), references will also be copied into the ZIP file. These references are not just files like templates but also SmartNames, profiles, scripts, referenced workflow tickets, marks etc.



**Attention:** Workflows that include referenced (blue) Job Tickets can not be exported. An error message will appear.



**Note:** Exchanging workflows is often done just to exchange the SmartNames used in those workflows. Learn more in [Exporting and Importing SmartNames](#) on page 660.

## 10.2.12. Good Practices for Building Workflows

Below tips help you build a workflow that is sustainable and easy to maintain. They also avoid extra work and cost when you upgrade or migrate server computers.



**Note:** Some of these tips are also present as an Esko Knowledge Base article. Find these and more on <http://help.esko.com/knowledgebase>.

### Avoid Absolute Paths and Server Names

Do you know the name of your file server in five years from now? Probably not. That is why we recommend to avoid using that computer name in your Tickets and Workflows.

For example when you define a template for the ReportMaker task. See below example of a Ticket with an absolute path to one specific template. If you have many such tickets, and the location of the templates changes, you then have to adjust all your ReportMaker tickets.

Report Template:  

This can be avoided by using a SmartName in the path. When the path changes, you then only have to update the SmartName.

Report Template:  

The SmartName can be a **String Extract SmartName** that contains the path or even just the server name:

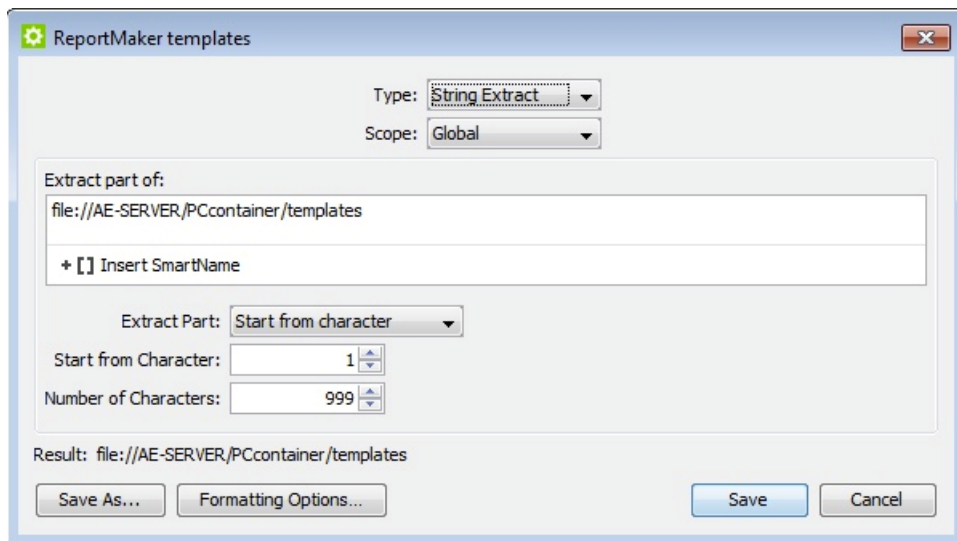

The same principle applies to other tasks with references to files or folders like **Compare PDF**, **Create CAD Sheet** and **Select File**. If you copy a PDF file to an external system, a CIP3 file to a press, a TIFF file to an imaging device, a JPEG preview to an MIS, a ZIP file to an archiving system etc., always avoid using server names and fixed locations.



**Note:** You can keep it even more generic. For example if your templates are saved on the Automation Engine server, you can use the system SmartName [Server] to make your path smart. No need to create an extra SmartName in this case, but you will have to keep the templates on the Automation Engine server when you migrate to new hardware.

Some typical situations where you better use SmartNames in paths:

- ReportMaker templates
- CAD files repository
- Image Mark files in SmartMark sets
- Files loaded in ArtPro Action Lists
- PDF, XML, JPEG communication with MIS/ERP
- TIFF, LEN, PS data sent to output devices
- Defining the file location of a Product.

For some situations, there is a default solution:

- In the Create Job ticket, use the Smart Job Location instead.
- Save PitStop Profiles in the default "PitStop Root" container (only visible in the PitStop ticket).
- FastImpose templates have a default location on the Automation Engine server.

## Annotate

If you are implementing a temporary workaround or even misusing a task to achieve your goals, make sure that you later remember why you did this. There might be a better solution or less strict requirements in a next version of Automation Engine. An exotic part of the workflow for which you don't remember why or how you did it, is a part that nobody later dares to change or remove. It will cause problems sooner or later.

The best way to manage this is to document on the spot. Automation Engine provides plenty of possibilities to do so:

- Description field for tickets and workflows
- Tags for tickets and workflows (also helps filtering)
- Renaming the workflow steps
- Description field for SmartNames
- Tags for SmartNames
- Sticky Notes in workflows

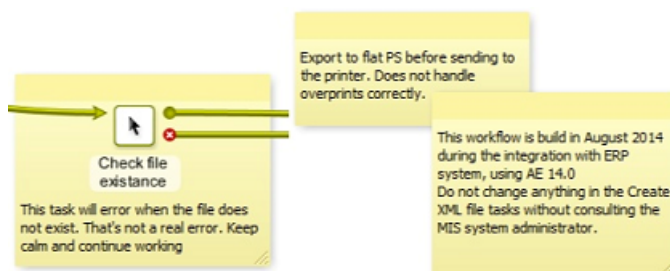
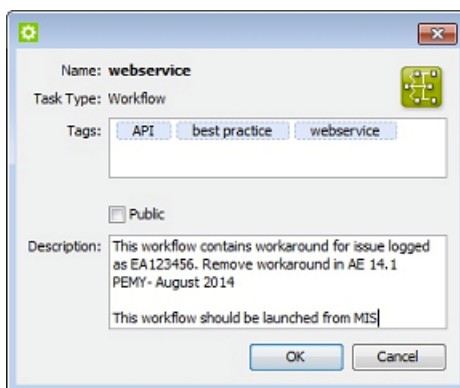

**Note:** Documenting your experiences while building a workflow is not only a great help for yourself and your colleagues but also for anybody at Esko Customer Service.

## Use Referenced Tickets and Workflows

### Referenced Tickets

You probably use several Export to PDF tickets. We advise to not copy-paste such a ticket in your workflows but to add a reference to this ticket. Then, when you decide to change a setting (for example "outline fonts"), you only have to change this single ticket and all the workflows that use it will so adapt and use these latest settings.

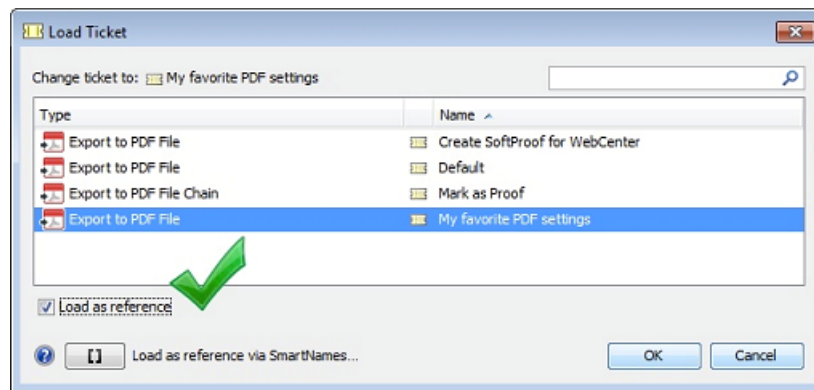

Learn more about referenced tickets in [Building a Workflow using Custom Tickets](#) on page 741.

### Reoccurring Workflows Parts

When part of a workflow is identical in other workflows, we advise to create it as a separate workflow and then refer to it from the master workflow(s).

For example, a part of your workflow sends feedback about a file to the business system. You probably use this part in several workflows. We advise to create it once and use it many times as a workflow step in various master workflows. We again advise to not copy it but to add it to the master workflow as a reference. This way, when settings change, you will only have to adapt it once.

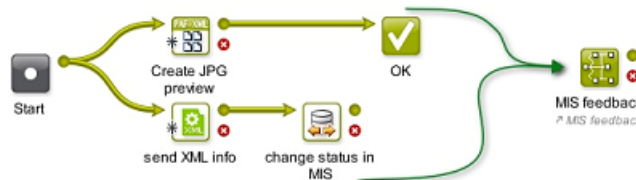

Workflows can get gigantic. When launching such a workflow, the Pilot will read all the settings of all the tasks in this workflow, even in the subworkflows. This is why launching bigger workflows seems slow. See an example of such huge workflows that you should try to avoid creating:

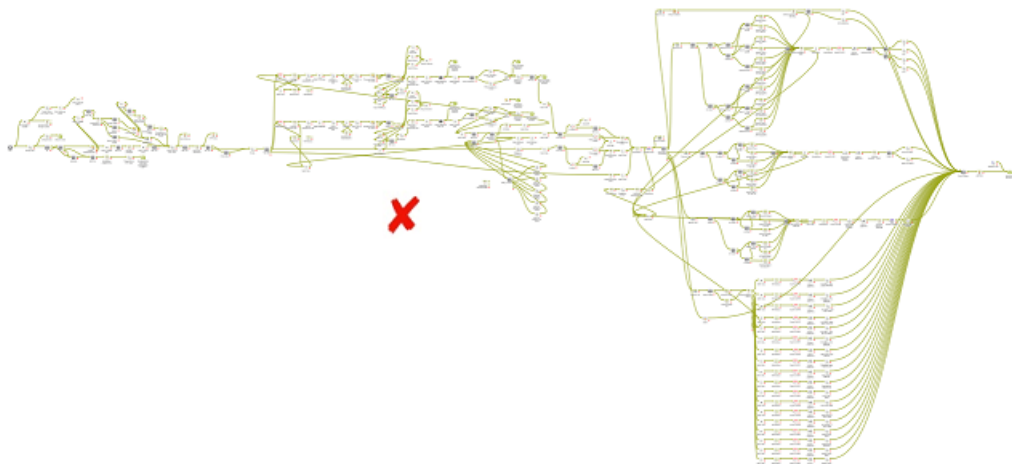

However, at the moment of launching, the Pilot will not immediately read the settings of a *referenced* workflow. This adds an extra reason to divide such huge workflows into several referenced workflows. The master workflow will not only react quicker, but will be much more structured and easier to understand.

Here is a good example of a master workflow that quickly visualises the logic workflow process steps:

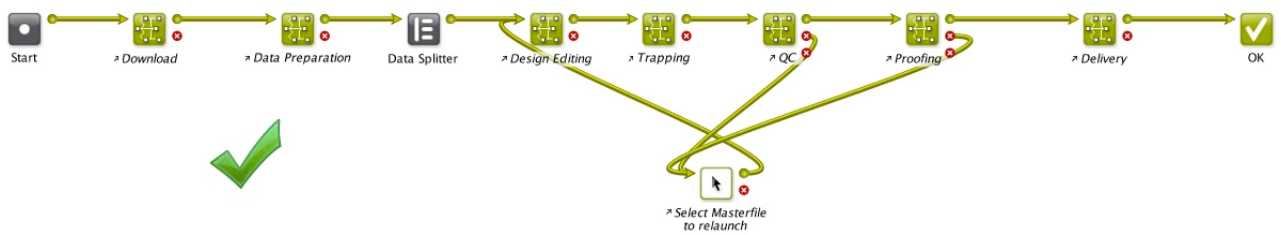

Learn more about copied and referenced subworkflows in [Subworkflows](#) on page 747.

### Avoid excessive amounts of Tokens

Learn about tokens in [Understanding Tokens \(Grouping of Output Files\)](#) on page 796.

#### Problem

Workflows that create an excessive amount of tokens will affect overall performance and stability.

Some constructions in a workflow ticket create a massive amount of tokens. Most typical constructs that can lead to such problems are

- Splitting without re-collecting later: For example a *Split XML* task followed by a *Data Splitter*. This way, one large XML file (one token) can – depending on how you split it – explode into hundreds of tokens that the workflow needs to manage in its next steps.
- Multiple inputs: Selecting a large amount of inputs files as initial input for a workflow.
- and of course a combination of the above.

**Solution**

Check the setup of that workflow. Analyse one that was launched or has finished ; you can then see where the 'explosion' of tokens starts.

Check how these tools can help creating less tokens:

- The workflow control *Data Collector*. It is OK to split, but always consider to collect again later.
- The *'Mark File' and 'Select Marked File'*. See an example below.
- Build checks into your workflow to detect and prevent an overload of tokens. See an example below.

Below examples contain some tips to avoid unnecessary build-up of tokens.

**Example 1 - Allow the workflow to NOT track and provide all details**

- An XML file lists the WebCenter projects where you need to launch a task for. The *Split XML* and the *Data Splitter* steps makes sure a task is launched for each project. This workflow will then track and trace all details of all 244 tasks that were launched in that subworkflow. The Tasks overview will show 491 entries for this workflow.



- An alternative is to use the *Launch Workflow* step: This allows the workflow to not track and trace all details of these 244 sub tasks. The Tasks overview will show 3 entries for this workflow.



**Example 2 - Enforce sequential processing and use checks**

- This workflow wants to launch several actions on the original input file. And these 4 actions do not need to work with output files from another (previous) action.

This is an example case to use the steps *'Mark File' and 'Select Marked File'*. Important effect is that workflow will not launch the 4 actions at the same time on that input file. They will happen **sequentially**, as you designed here in the workflow. This will be much better for the load on your workflow server than starting them all at the same time from the beginning.

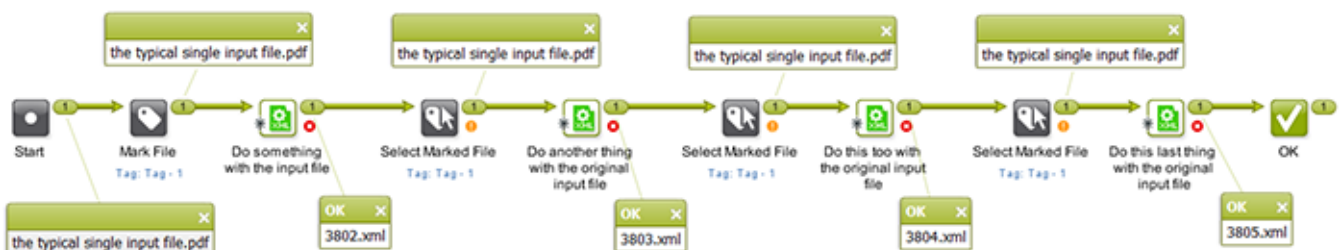

- In several cases, it can happen that your workflow gets an unexpected input file (a wrong manual selection, a wrong decision by an external system, a bad timing on some Access Point, etc.).



See how, even in the above improved workflow, 1 extra unexpected input file can lead to many more tokens:

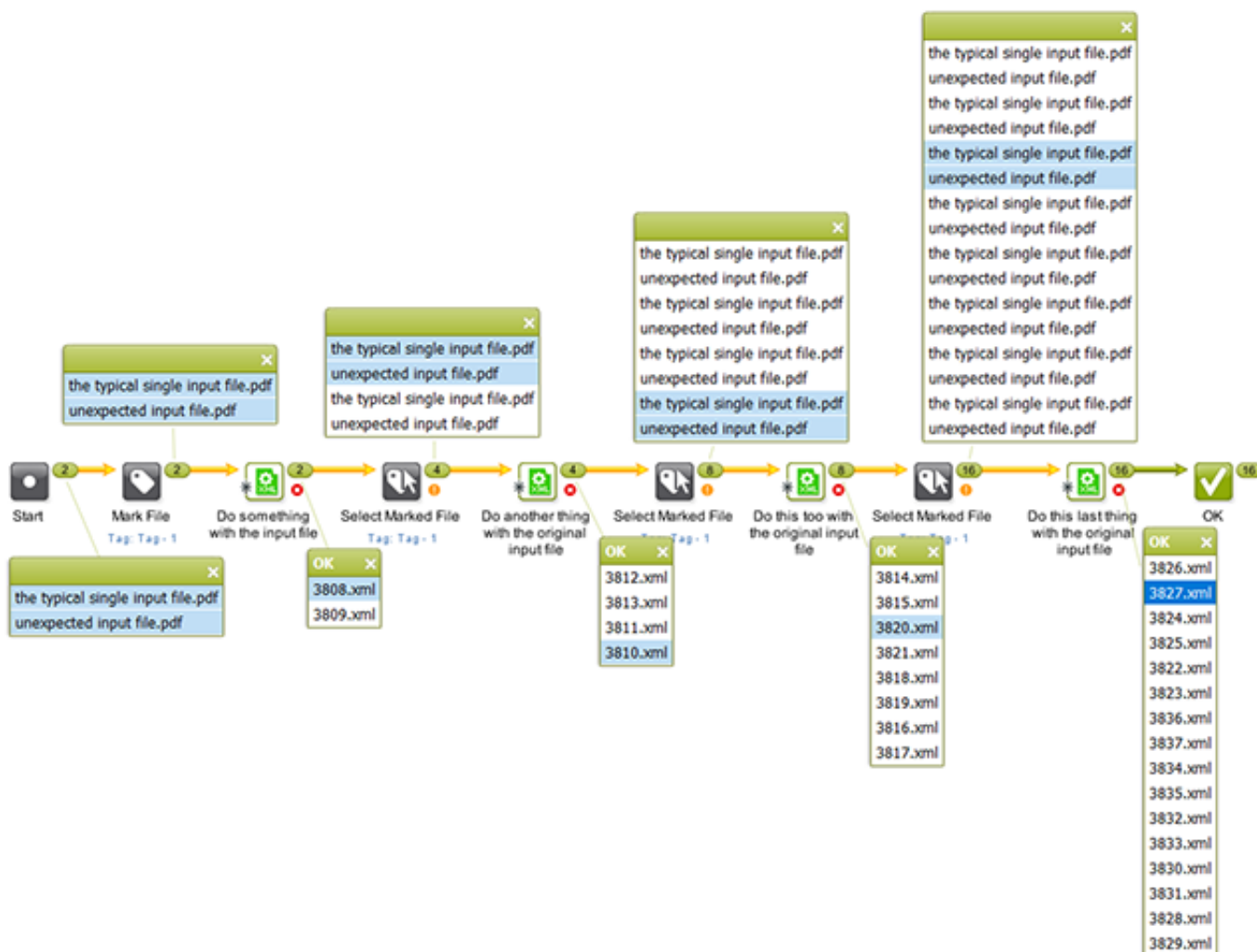

- A way to prevent this is to start with a checkpoint. In this case a [Router](#) that will only allow the usual workflow to continue when the amount of input files is the expected '1':



## 10.3. Launching and Diagnosing Workflows

### 10.3.1. The Parameter Inspector

The **Parameter Inspector** enables you to quickly view or change the ticket parameters of your workflow steps, without having to open and close each workflow step separately.

Open it by choosing **Show Parameter Inspector...** from the workflow editor **File** menu or by choosing the same option after a right-click on the canvas.



**Note:** The parameter inspector is not available for workflows that were already launched (running or finished).

The window stays open while you navigate through the steps. The steps are shown in alphabetical order. You can navigate through the steps by selecting them in the parameter inspector or by clicking on steps in the workflow editor canvas.

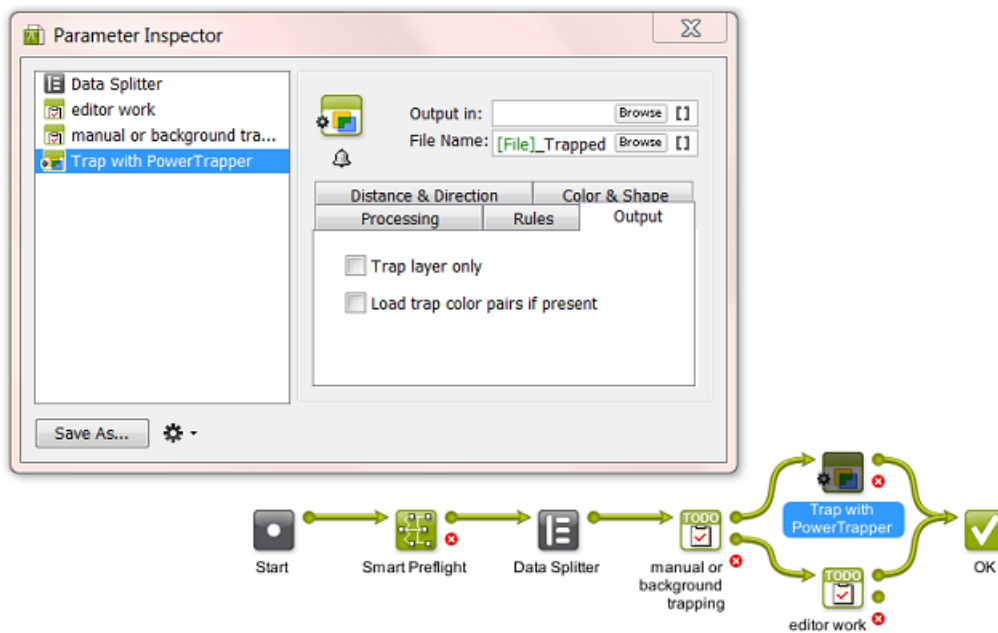

The parameter inspector does not show

- steps that have no parameters (Start - Stop - Warning - Error - Cancel)
- subworkflow steps. Double click the subworkflow step on the canvas to see its own steps appear in the same parameter inspector window.
- referenced steps.

When available, you can

- choose **Save As...** to save the selected ticket as a separate task ticket.
- choose  to set extra options that you can also set when you open the ticket separately: [Notification Rules](#), [Manage Public parameters](#) and [Map Output Parameters](#).

### 10.3.2. Launching a Workflow on a File

There are several ways to launch a workflow on a file: from the Pilot or browser client, from within the Workflow Editor, from [Shuttle](#), via Access Points or via JDF/JMF.



**Note:** Learn more about launching workflows from external systems in [Integrating with External Systems](#) on page 1769.

Launching a workflow from the Pilot's **Files** View is very similar to launching a single Ticket. Follow these steps:

1. In the **Files** view, right-click the file(s) you want to process and select:
  - **New Task.** Choose this to select a workflow and view or change its settings before launching it.
  - **Launch with.** Choose this to select a workflow and launch it without changing its settings.



**Note:**

If you don't have the access right **Tickets: Show All Tickets and their Parameters (Public and other)**, you will only see **Launch with**. You will also only be able to select public workflow tickets. Learn more in [Access Rights](#) on page 157.

2. Select the workflow ticket to use.
  - If you have launched workflows previously, the most recent workflow tickets you used are listed under **Workflow**.

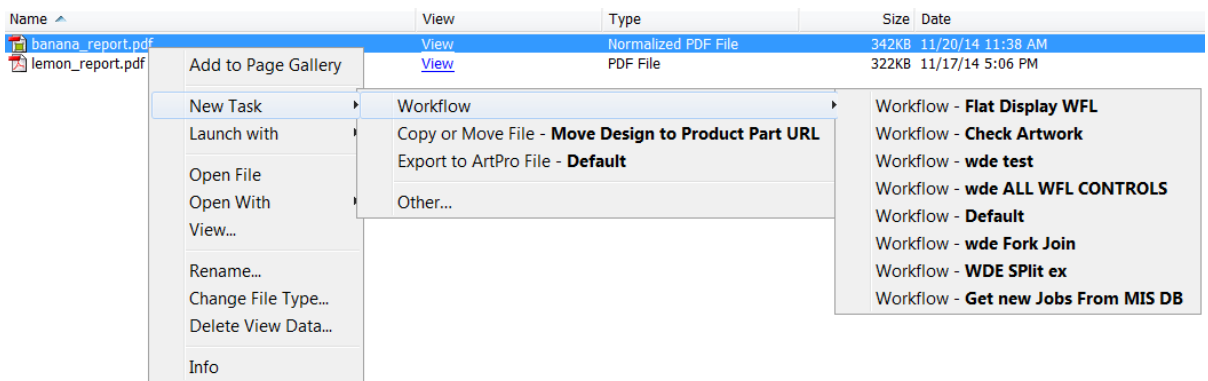

- If you don't need a recently used workflow, select **Other....** In the **Select Ticket** dialog, select the workflow ticket you want to use and click **OK**.

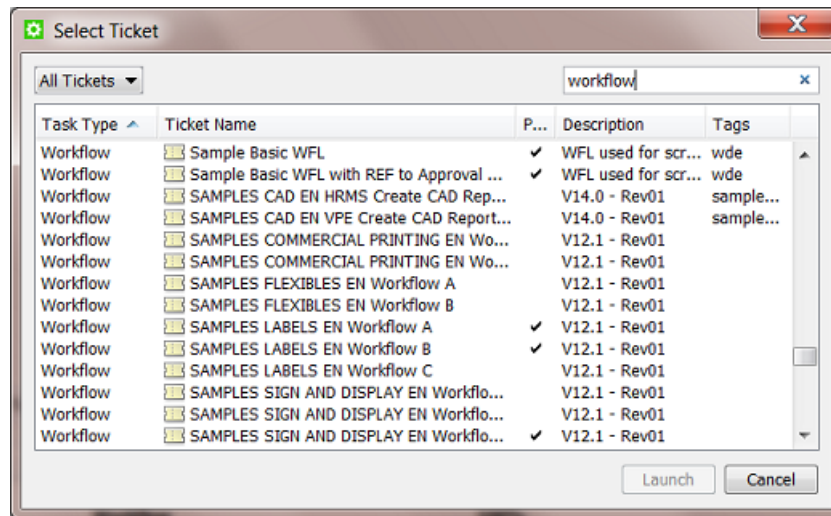



**Tip:** Type `workflow` in the search field to quickly filter to the task type **Workflow**.



**Tip:** If you hold the **Alt** key, the **OK** button changes into **Launch**.

**3.** Some variations are possible:

- To keep the workflow editor window open and monitor the workflow while it is executing, hold **Alt** while clicking Launch to **Launch and Monitor** (the Launch button changes to ).
- If you choose **New Task**, the workflow editor opens. Fill in the settings you want to use in each workflow step and click the Launch  button.
- If you choose **Launch with** and you don't have the access right **Tickets: Show All Tickets and their Parameters (Public and other)**, then
  - if the ticket does not contain public parameters, the workflow is launched on the file as soon as you select the workflow ticket.
  - if the ticket contains public parameters, it will open for you to fill them in. You will only see the public parameters. Click the **Launch** button when you are done.

In this example the user is asked to decide 2 public parameters:

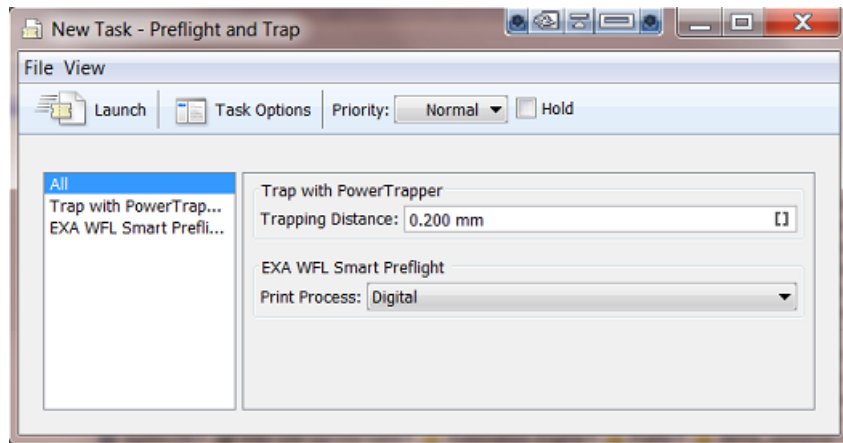

**Note:** If a workflow is launched on files that are linked to several Jobs, a separate workflow will be launched for each Job context. This can happen for example when you use the **Files** view or Shuttle or a Folder Access Point.

### 10.3.3. Using Favorite Workflow Tickets



**Note:** In [Creating Favorite Tickets](#) on page 91, you can read how to build and launch **Favorite** tickets for single task tickets. You can do the same for workflows tickets, including [sorting and grouping them](#). We here repeat some information and add specifics about working with favorite workflows.

Favorite tickets are links to tickets that you use a lot. They show up in the **Favorites** pane, both in the Files and in the Tickets View. You can use **Pilot > View > Favorites** to show or hide the **Favorites** pane.

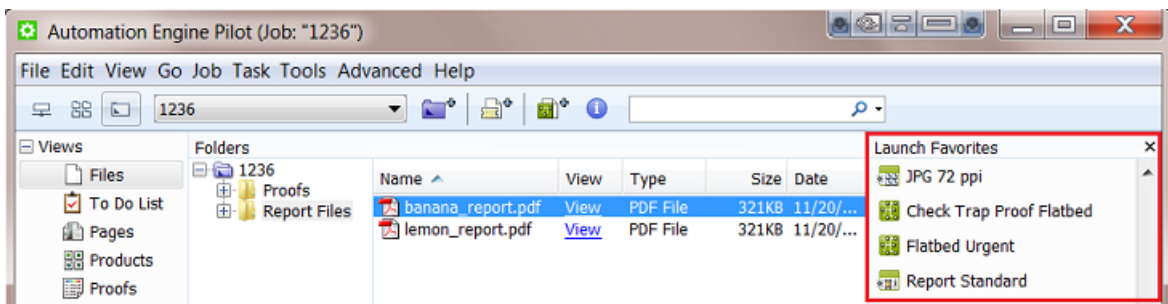

Favorites tickets show up depending on

- the file type you selected first.
- the user that is logged in. They are your personal favorites.



**Tip:** You can copy and paste favorite tickets from one user to another. In **Pilot > Tools > Users**, right-click a user name and choose **Copy** or **Paste Favorites**.

### Adding Favorite Workflow Tickets

There are 3 ways to create a favorite (workflow) ticket:

- when you first save a workflow or use 'save as', then check **Add to Favorites**.
- in the Tickets view, right-click a ticket and select **Add to Favorites**. Use **Shift** to select multiple tickets.
- both in the Files and in the Tickets View, in the **Favorites** pane, right-click and choose **Add Favorite....**

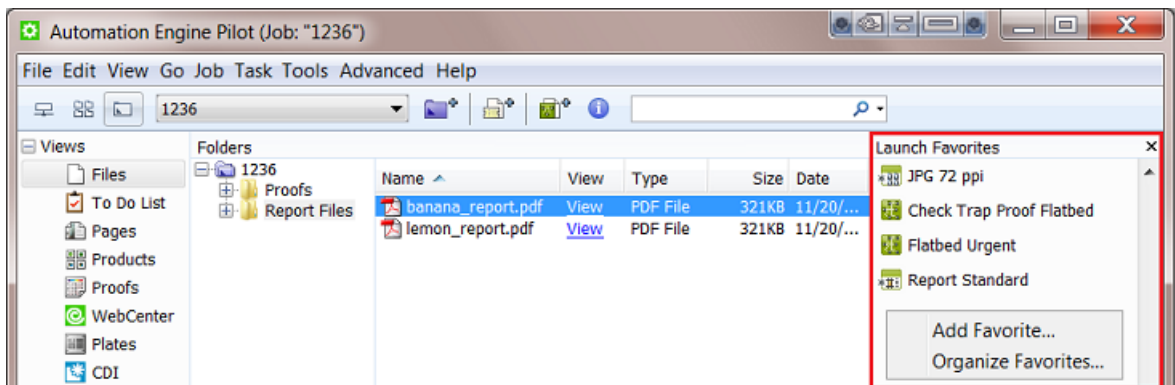

### The Add Favorite Dialog

When selecting a (workflow) ticket to add as a favorite, these 2 tools help you filter your list of tickets:

1. Instead of seeing **All Tickets**, use the drop-down list and select one of the tickets filters that you created earlier and saved into your **Smart Views**. Learn more about Smart Views [here](#).
2. Type in a filter in the search field. What you type will be used to filter in all the columns.

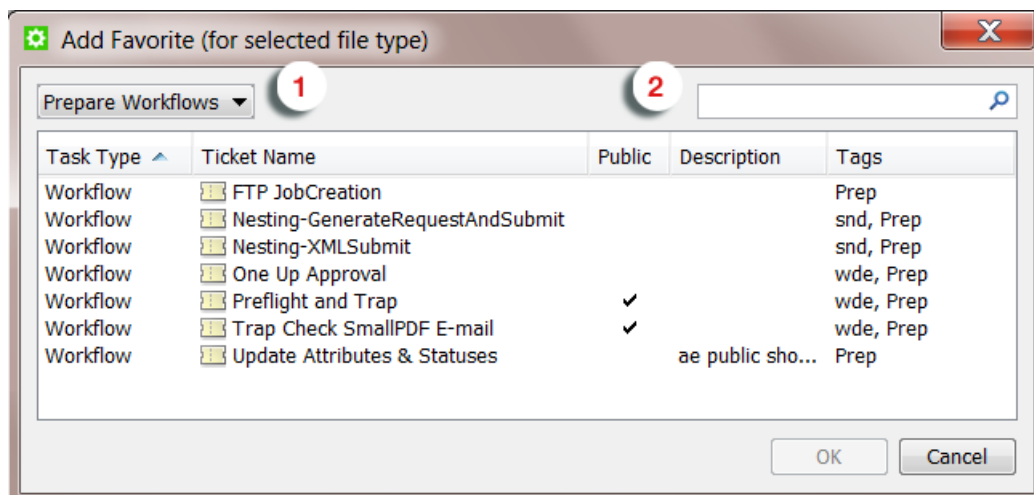

### There is No Need to add Many Favorites of Same Task Type

When you click on the right side of the favorite, a drop-down list will show you all tickets of the same task type (with a maximum of 10). This easy access to similar tickets means that you do not have to create a favorite of those other similar ones (when you also use them often).

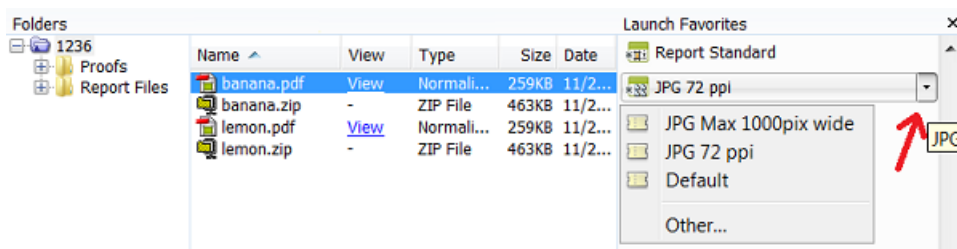

When the ticket that you look for is not in that list (remember that maximum 10 are shown), you can choose **Other...** and select it there.

### Adding a Favorite based on a SmartName

Right-click a favorite and choose **Edit Favorite**.

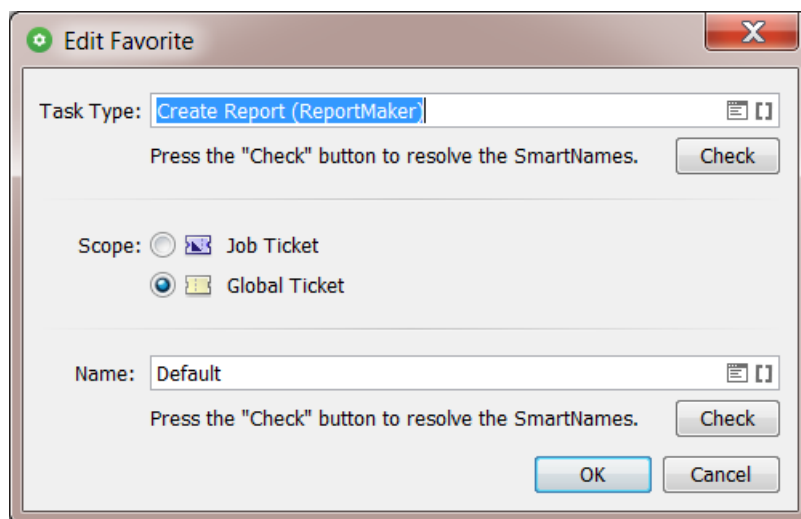

Click to pick a **Task Type** and or **Name** of the favorite ticket from a list.

Click to define the Task Type and or the Name by a *SmartName*.

An example:

This favorite ticket will create a report file that uses a template chosen according to the category of job it is. It will pick a ticket with a name that mentions the **Job Category**:

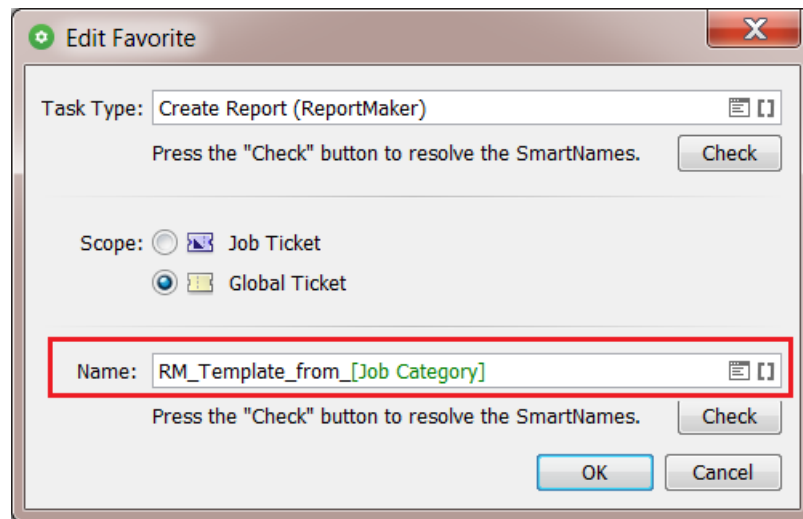

Click **Check** to test what that Name (or Type) field will resolve to. That is the name of the ticket that will be picked up. So make sure a ticket with that exact name (and of that type) does exist.

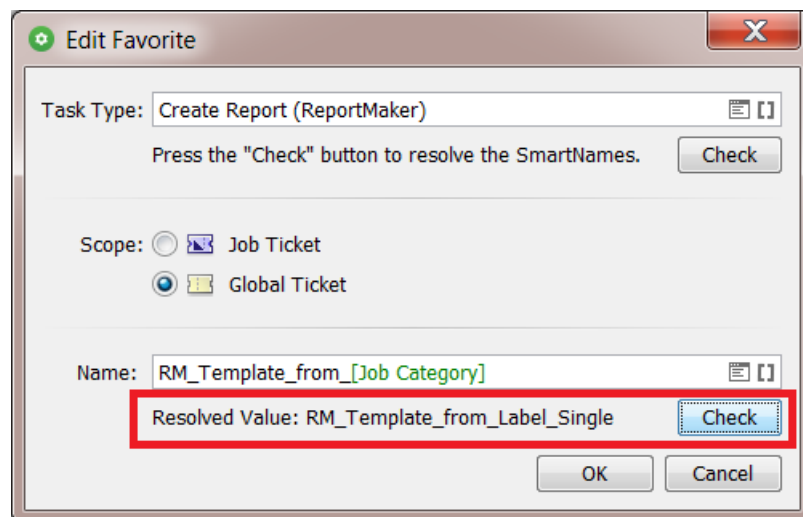

After you click **OK** to close this dialog, the pane of Favorites in your Pilot will show what the actual name is for this ticket, in this case based on the job it belongs to.

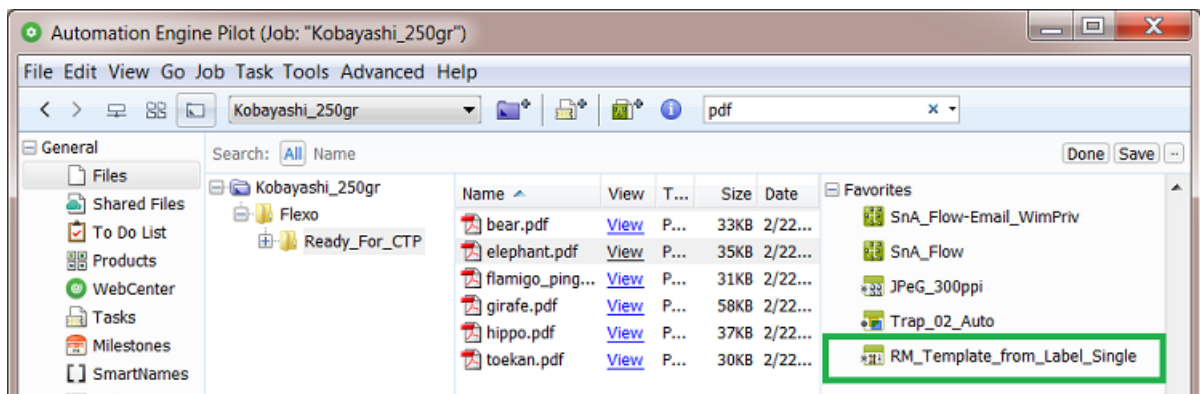



When the SmartName's **Resolved Value** does not match an existing ticket name, then that favorite will be shown as **<Unresolved>**. It is unusable, not in this specific context as required by this SmartName.

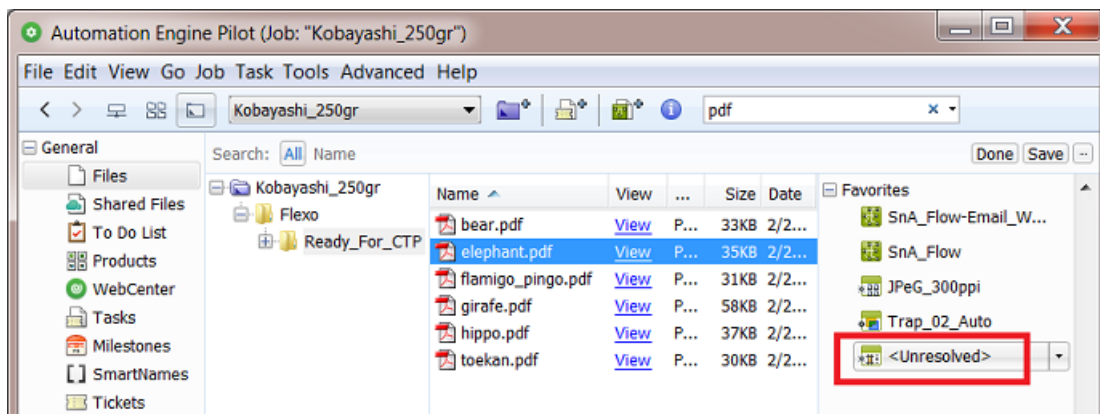

### Launching Favorite Workflow Tickets

There are various ways to launch a favorite (workflow) ticket:

#### Launch Immediately

1. Select file(s).
2. Hold the **Alt** button.
3. Click on your favorite. The task is launched.

#### Choose a Ticket of the Same Task Type and Launch Immediately

1. Select file(s).
2. Hold the **Alt** button.
3. Click on the right-side of a favorite to open the drop-down list of tickets of the same task type.
4. Move your mouse down to the chosen ticket.
5. Click on the chosen ticket. The task is launched.
6. Release the **Alt** button.

#### Open the Favorite Ticket in the Workflow Editor

1. Select file(s).
2. Click on your favorite.
3. In the workflow editor, check or change the settings and then launch or 'launch and monitor'.

#### Choose a Ticket of the Same Task Type and Open it in the Workflow Editor

1. Select file(s).
2. Click on the right-side of a favorite to open the drop-down list of tickets of the same task type.
3. Move your mouse down to chosen ticket.
4. Click on the chosen ticket.

5. In the workflow editor, check or change the settings and then launch or 'launch and monitor'.

### 10.3.4. Building and Launching a Workflow On The Fly

If you build a workflow from the **Tickets** view, you cannot launch it until you finished building it. Your Workflow Editor will not have a **Files** pane to select files and then launch it. Working this way is typically something done by Automation Engine administrators while building the workflows. Once the workflow is ready for testing, users can then go to the **Files** view, make a file selection, select the workflow ticket and launch it.

However, you do not always have to prepare a workflow ticket before you can launch it. It is possible to build the workflow and launch it on a file without first saving the workflow ticket. Follow these steps to do this:

1. In the **Files** view, select the file(s) you want to launch your workflow on.



**Note:** If you need to select files from different (Job) folders, then first select those in one same folder, then choose **New Task** or **New Workflow** to open a Workflow Editor and there use the **Select File** tool to select the files from any other folders (see step 4).

2. Click  to open the workflow editor.

You can see the file(s) you selected in the **Files** pane of the Workflow Editor.

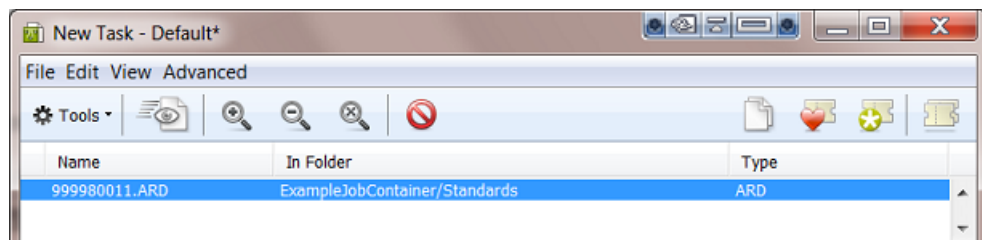

3. Build your workflow and define the settings of every step.
4. If you want, select more files. Right-click in the **Files** pane and choose **Select File...**

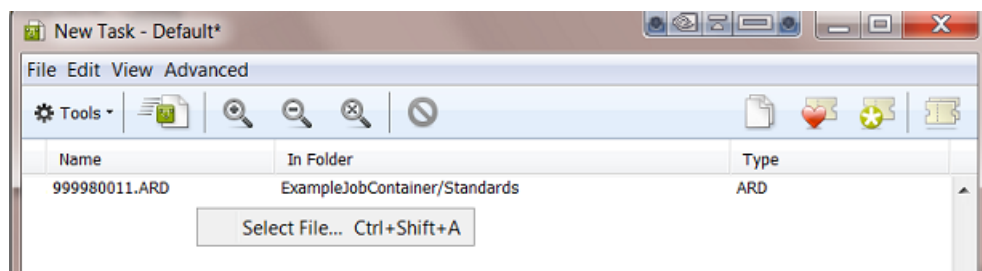

In the dialog that appears, select files from folders in **Jobs** or **Containers**.

5. Click the Launch  button. Hold **Alt** to  **Launch and Monitor** and keep the workflow editor open.

- If you kept the workflow editor open, continue by changing the workflow settings, [relaunching](#) or launching on different files. When ready, save your workflow ticket.

### 10.3.5. General Workflow Task Options

**Task Options** are options that will be used when you push the **Launch** button (both here in the workflow editor and also in a single task ticket). These settings are not saved into the (workflow) ticket.

Open **Task Options** from the menu **Advanced** in the workflow editor:

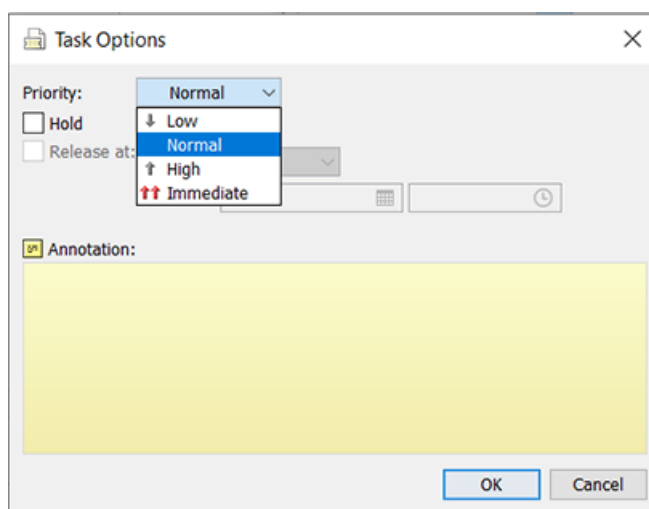

- Priority:** Choose the general priority with which you want to launch this workflow. The default is **Normal**.



**Note:** To choose **High** or **Immediate**, you need a special [User Access Right](#).



**Note:** You can also choose to set the priority of only a part of the workflow. Learn more in [Set Priority](#) on page 824.

- Hold:** Check this when you want to hold the workflow when you launch it. The workflow will start but immediately go into 'pause' mode. You can then later decide when to use the **Release** button to start it for real.
- Release:** When you decided to use **Hold**, you can set a time when the workflow should be released automatically. Choose a relative or absolute time.
- Launch a separate task per input file:** Choose this option when you selected multiple input files but when you still want to launch a separate workflow task per input file.
- Annotation:** When testing many workflow tasks or many versions of a workflow, it can be useful afterwards to read some notes that you added before launching it. Once the task was launched, you can read these annotations from this same menu or you can read them in the Tasks view when you right-click the main workflow task line (in bold).

For example: "This task was only launched to create the temporary files that I need to test the next one."

### 10.3.6. Relaunching Your Workflow with Different Settings

You can relaunch a workflow from the **Tasks** view and from the **Workflow Editor** (skip step 1):

1. In the Tasks view, double-click the main **Workflow** line to open your workflow in the workflow editor.

1236	banana.pdf,banana_report.pdf	Zip	100%		11/20/14 4:20 PM
1236	lemon.pdf,lemon_report.pdf	Zip	100%		11/20/14 4:20 PM
1236	lemon.pdf	Create Report (ReportMaker)	100%		11/20/14 4:20 PM
1236	banana.pdf	Create Report (ReportMaker)	100%		11/20/14 4:20 PM
1236	lemon.pdf	Optimize and Clean (PSFix)	100%		11/20/14 4:20 PM
1236	banana.pdf	Optimize and Clean (PSFix)	100%		11/20/14 4:20 PM
<b>1236</b>	<b>banana.pdf,lemon.pdf</b>	<b>Workflow</b>	<b>100%</b>		<b>11/20/14 4:20 PM</b>



**Tip:** The workflow can be opened and relaunched even when it is still running.





**Tip:** If you double-click any sub-step of the workflow, only that ticket will open. You can also relaunch just that separate single step (if the input files are still available).

2. In the workflow editor window, click the **Edit Workflow** button  if you want to make any changes.

When you are finished making changes, and if you want to keep the new settings before you try them out, save your workflow now.



**Note:** As soon as you make one change, the name of the workflow ticket in the top bar will show an asterisk \* behind the name to indicate that it has been changed.

3. Click Launch  or press **Alt** while clicking Launch to **Launch and Monitor** .

### 10.3.7. Diagnosing a Workflow in the Tasks Pane

You can check the processing status of a workflow in the Pilot's **Tasks** pane. The **Tasks** pane appears in the **Files, Products** and **Tasks** View.

Job Name	File Name	Task Type	Progress	Phase	State	Launched
1236	lemon.pdf	Create Report (ReportMaker)	0%	Reading \\...		11/20/14 4:30 PM
1236	banana.pdf	Create Report (ReportMaker)	0%	Reading \\...		11/20/14 4:30 PM
1236	lemon.pdf	Optimize and Clean (PSFix)	100%			11/20/14 4:29 PM
1236	banana.pdf	Optimize and Clean (PSFix)	100%			11/20/14 4:29 PM
<b>1236</b>	<b>banana.pdf,lemon.pdf</b>	<b>Workflow</b>	<b>0%</b>	<b>Running</b>		<b>11/20/14 4:29 PM</b>



**Attention:** The **Tasks** pane does not show the **Workflow Controls** that may be part of your workflow. To diagnose them, use the Workflow Editor.

#### Workflow Status

The workflow status can be

- ▶: running, when one or more steps are waiting to be handled.
- ✔: success, when all steps finished successfully.
- ⚠: warning, when one or more steps finished with a warning.
- ✖: failed, when one or more steps finished with an error.
- ⏸: cancelled, when a user cancelled the processing.

### Right-Click and Diagnose Further

Right-click or Cmd-click any task line to see many functions available for that task or its related files.

The availability of the functions depends on

- if the task is already finished or not
- if the task is the initial 'workflow' task type or any sub-step of that workflow.

Job Name	File Name	Task Type	Progress	Phase	State	Launched
1236	lemon.pdf,lemon_report.pdf	Zip	100%		✖	11/20/14 4:30 PM
1236	banana.pdf,banana_report.pdf	Zip	100%		✖	11/20/14 4:30 PM
1236	lemon.pdf	ReportMaker	100%		✔	11/20/14 4:30 PM
1236	banana.pdf	ReportMaker	100%		✔	11/20/14 4:30 PM
1236	lemon.pdf	an (PSFix)	100%		✔	11/20/14 4:29 PM
1236	banana.pdf	an (PSFix)	100%		✔	11/20/14 4:29 PM
1236	banana.pdf,lemon.pdf		100%		✖	11/20/14 4:29 PM
1236	banana.pdf,banana_r		100%		✔	11/20/14 4:20 PM
1236	lemon.pdf,lemon_rep		100%		✔	11/20/14 4:20 PM
1236	lemon.pdf	ReportMaker	100%		✔	11/20/14 4:20 PM
1236	banana.pdf	ReportMaker	100%		✔	11/20/14 4:20 PM
1236	lemon.pdf	an (PSFix)	100%		✔	11/20/14 4:20 PM
1236	banana.pdf	an (PSFix)	100%		✔	11/20/14 4:20 PM
1236	banana.pdf,lemon.pdf		100%		✔	11/20/14 4:20 PM
WDETESTS	78999_ABC_report.pdf		100%		✔	11/20/14 4:08 PM
WDETESTS	99998011.ARD		100%		⚠	11/20/14 3:13 PM
WDETESTS	78999_ABC_report.pdf		100%		⏸	11/20/14 2:25 PM
1237	South.pdf	Checkpoint)	100%		✔	11/20/14 1:48 PM
1237	South.pdf		100%		✔	11/20/14 1:48 PM
1237	South.pdf		100%		✔	11/20/14 1:48 PM
WDETESTS	78999_ABC.pdf	Checkpoint)	100%		✔	11/20/14 1:48 PM
WDETESTS	78999_ABC.pdf		100%		✔	11/20/14 1:48 PM
WDETESTS	78999_ABC.pdf		100%		✔	11/20/14 1:48 PM
WDETESTS	banana_report.pdf	Checkpoint)	100%		✔	11/20/14 1:28 PM
WDETESTS	banana_report.pdf		100%		✔	11/20/14 1:28 PM
WDETESTS	banana_report.pdf		100%		✔	11/20/14 1:28 PM
WDETESTS	banana_report.pdf	Checkpoint)	100%		✔	11/20/14 1:27 PM
WDETESTS	banana_report.pdf		100%		✔	11/20/14 1:27 PM
WDETESTS	banana_report.pdf		100%		✔	11/20/14 1:27 PM
WDETESTS	banana_report.pdf	base	100%		✖	11/20/14 12:14 PM

These functions are documented in [Functionality on items in Tasks View](#) on page 126.

Some specific notes:

- Delete.** If you decide to manually delete tasks, then you best delete the main workflow task step so that all related task steps are also cleaned up. In general we advise to use the automated version based on the standard **Task Cleanup Rules** that you set up in the Configure tool.

- **Move to History.** Same comments as above for the **Delete** function. Learn more about storing task details in [Task History](#) on page 164.

### 10.3.8. Diagnosing a Workflow in the Workflow Editor

#### General View

In the workflow editor, you can see your file(s)  going from step to step, with their processing **Phase** displayed in blue text.



**Note:** This icon  can represent a single file or a collection of related files.

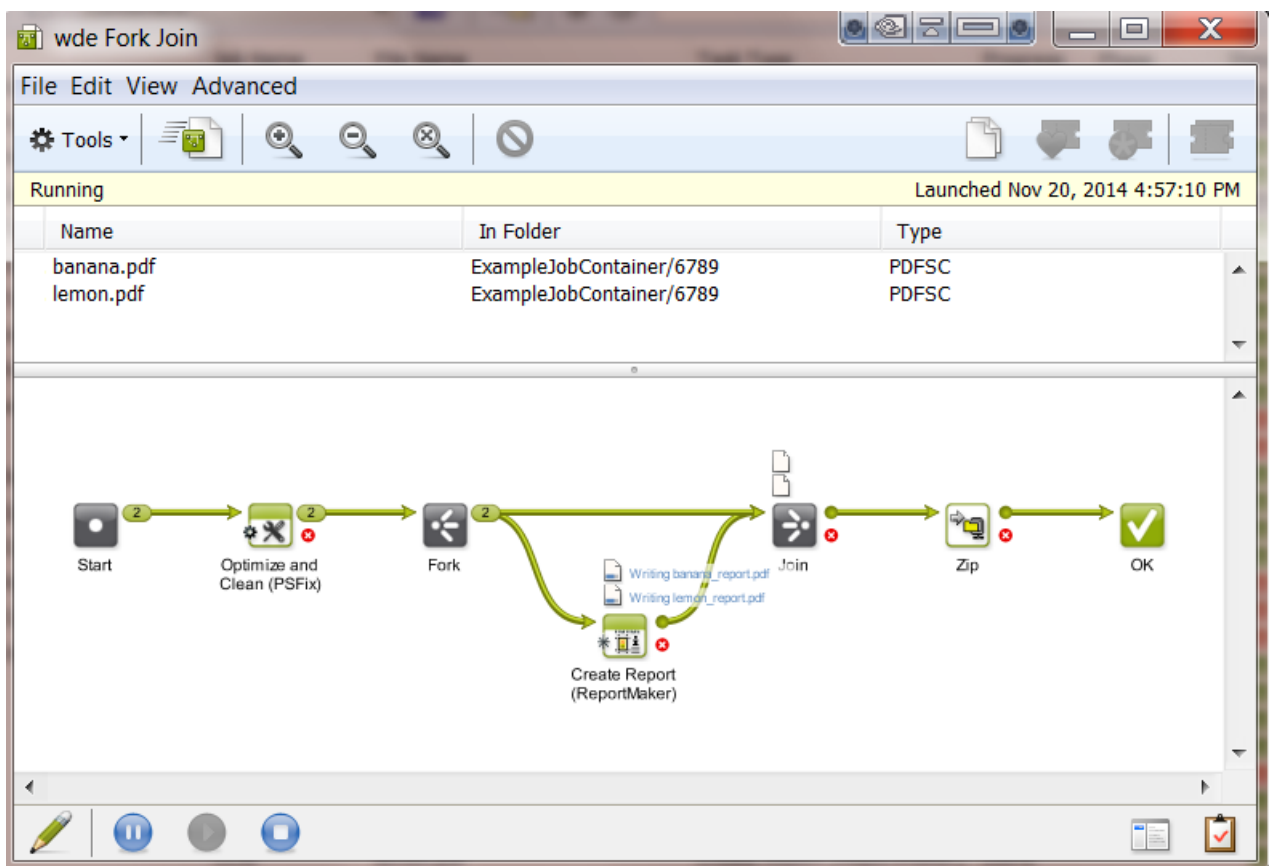

- Click  to see the **Details** of the main workflow task (names of output files, stranded files, reading of workflow parameters...).



**Tip:** If you want the details of a specific workflow step, then first select one of the output files of that step and then right-click and choose **Details**.

- Click  to see the **To-Do** action items associated with this workflow.

### Output Pins and Widgets

A number in the output pin of a step indicates the number of files that ran through it.





Click on the number to open a widget showing the file names.

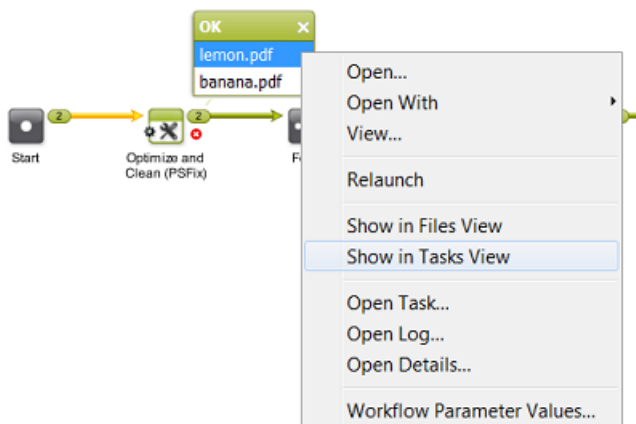

**Note:** The items in these output widgets are actually more than files, technically we name them tokens. A token could consist of one file, or many files or even be empty. Learn more technical detail in [Understanding Tokens \(Grouping of Output Files\)](#) on page 796.

Inside the widget, right-click the name of a file (token) to see more options. Many of these options were explained in [Diagnosing a Workflow in the Tasks Pane](#) on page 790.



**Note:** You can also right-click the icons  of files that are still being processed and get more options there.



**Note:** To check the **Workflow Parameter Values** of a (collection of) file(s): learn more in [Using Workflow Parameters](#) on page 859.

### Seeing the Followed Path

In an output widget, click on a file name to see which path it followed. In this example we clicked on `lemon_report.pdf`. The name is highlighted in blue and the path that this file followed so far is shown in yellow.

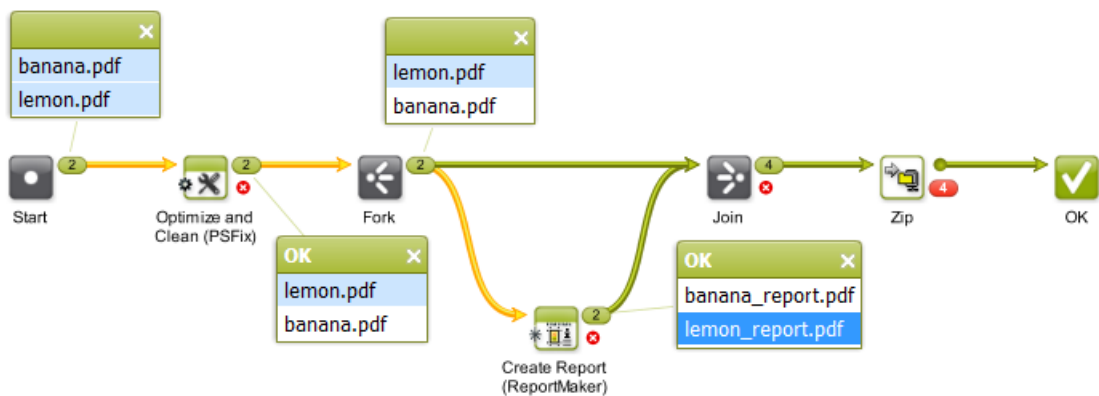

### Seeing the Related Files

Clicking on a file name also helps diagnosing the relations between files. In below example we clicked on `lemon.pdf` in the 'Error' widget. This highlights all related files in a light blue color. These relations were created during their processing.

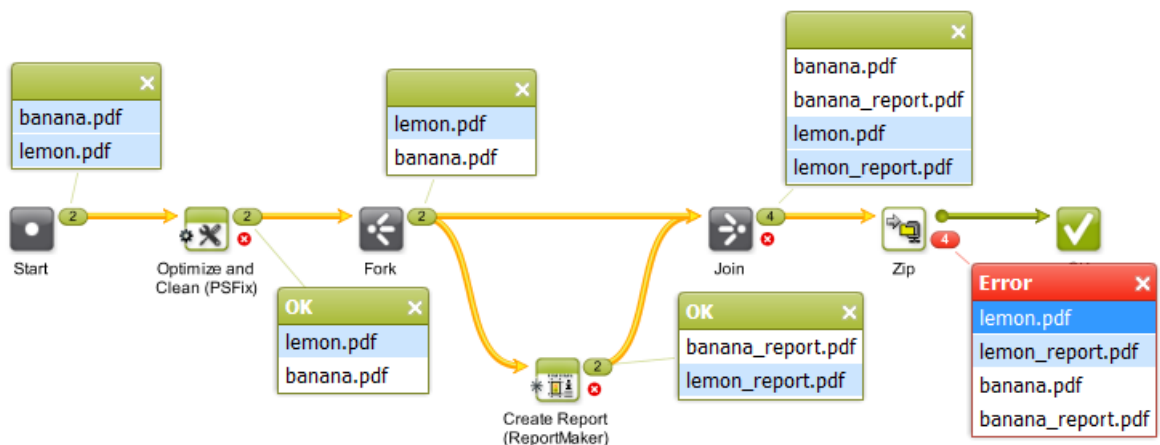

**Note:** Files that are related to each other in a workflow will also share the same workflow parameters at that specific step of the workflow. Learn more in [Using Workflow Parameters](#) on page 859.

### Diagnosing an Error



In below example, we right-clicked on a file in the 'Error' widget and asked the **Open Details ...**. This explains the error: the zip was not created because it already exists (and the ticket had the setting to fail in that case). Sometimes, you will need to **Open Log ...** to find what you are looking for.

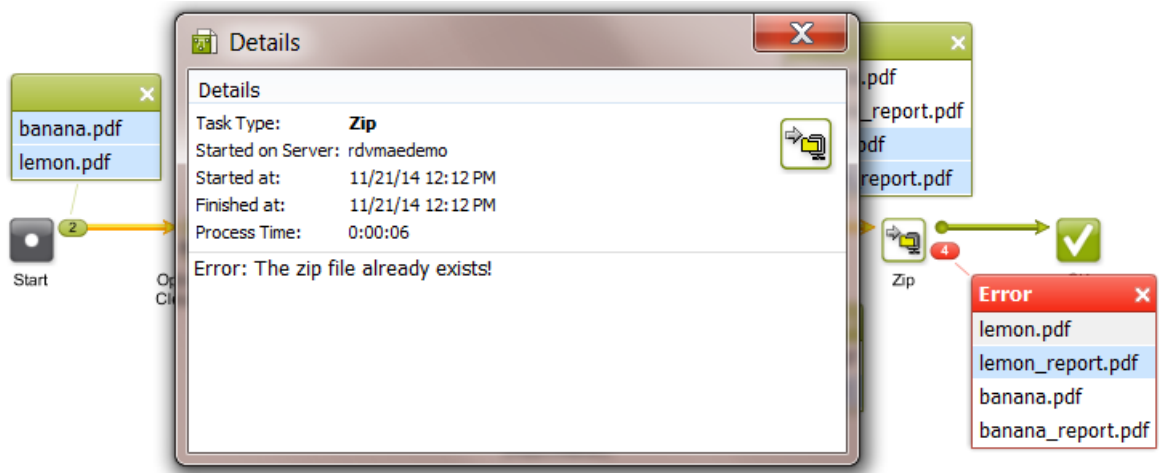



**Details** is meant for the user and is translated. **Log** info is mainly for Esko service people, it is more complex and also not translated.

In this example, you could now continue with these steps:

1. Click on  to edit the workflow.
2. Double click the **Zip** task, change the setting that generated the error and click **OK** to confirm and close the ticket.
3. Launch this changed workflow: click  or press **Alt** and click .
4. If you prefer this new setting, save your workflow.

### Error Files or Invalid Files

See the open widgets of this example workflow:

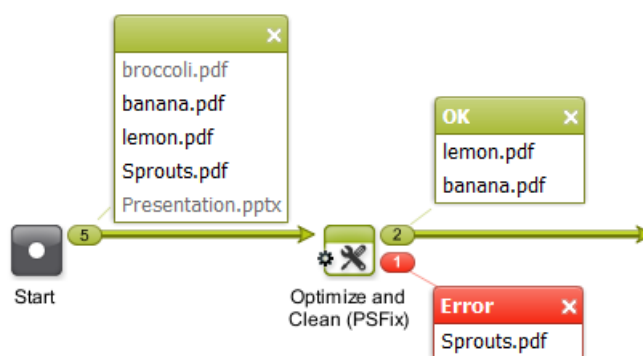

- In the widget of the **Start** step, `broccoli.pdf` and `Presentation.pptx` are shown in grey because they are not valid for the next step in the workflow.
  - `broccoli.pdf` is invalid because it has a size of 0 Kb.
  - `Presentation.pptx` is a PowerPoint file and that is not a valid input file type for the next step.



**Note:** Both file names would be shown in black when the next step would for example be a **Copy or Move File** task.

- banana .pdf and lemon .pdf are valid PDFs.
- Sprouts .pdf: Based on its extension '.pdf', the file was valid for the next step but it still resulted in an error (the task detected that the file was not really a PDF file).

### 10.3.9. Understanding Tokens (Grouping of Output Files)

#### Concept

Automation Engine internally decides how files are grouped as they progress through a workflow. When a workflow step has more than one input file, it then depends on what workflow step it is whether those files are handed over to the next step as separate files or as a group.

Automation Engine groups output files by attributing them a same **token** (an internal ID number). This token is not shown in the user interface. Files will seem grouped because they were attributed a same token. The next step in the workflow receives one or multiple such groups from the previous one. The next workflow step(s) typically starts a task per such group, technically 'per token'.

This internal behavior of the software is visualised in the **widgets** that list the output files of a workflow step. You can also see how the system works with groups or tokens in the list of **Tasks**.

#### Example

An example:

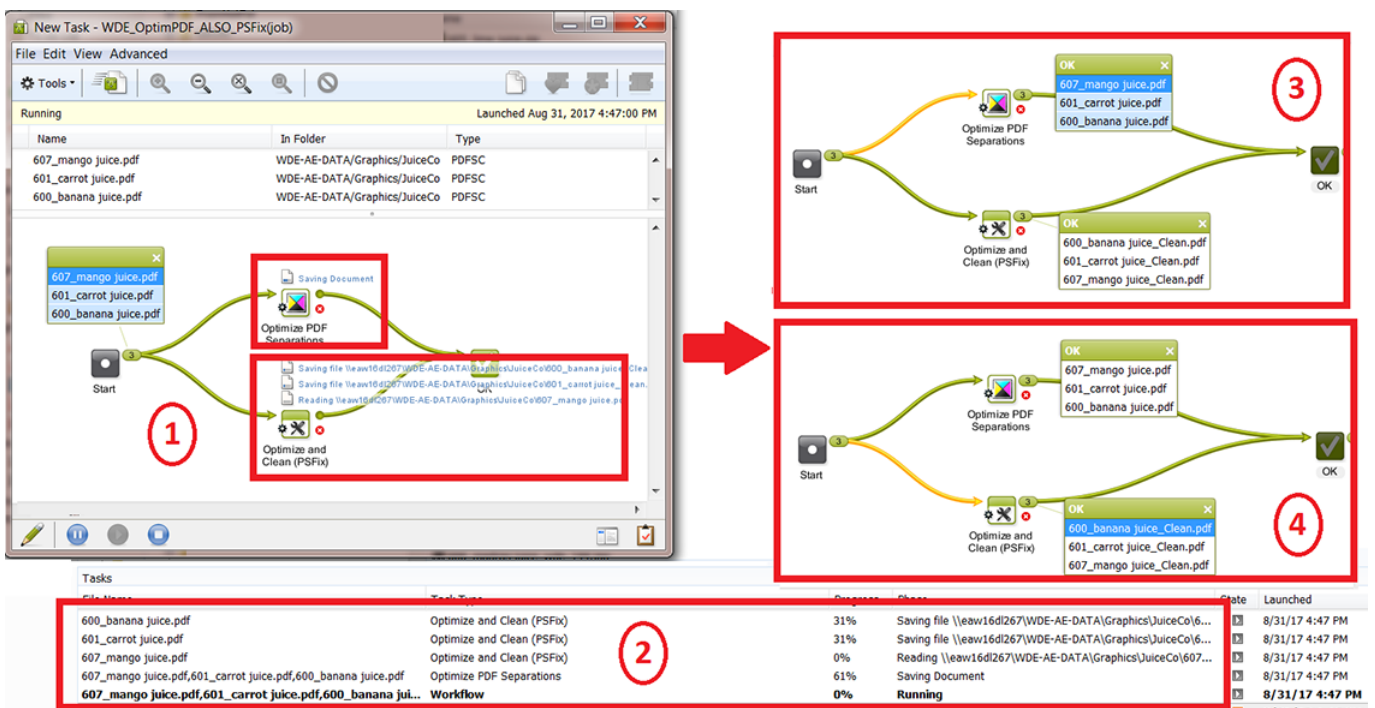

The screenshot illustrates the Automation Engine interface during a workflow execution. On the left, a window titled 'New Task - WDE\_OptimPDF\_ALSO\_PSFix(job)' shows a workflow diagram. The 'Start' node (1) leads to 'Optimize PDF Separations' (2), which then branches into two 'Optimize and Clean (PSFix)' tasks (3 and 4). The task list at the bottom shows the execution of these tasks with progress percentages and timestamps.

File Name	Task Type	Progress	State	Launched
600_banana juice.pdf	Optimize and Clean (PSFix)	31%	Saving file \\leaw16dl267\WDE-AE-DATA\Graphics\JuiceCo\600_banana juice_Clean.pdf	8/31/17 4:47 PM
601_carrot juice.pdf	Optimize and Clean (PSFix)	31%	Saving file \\leaw16dl267\WDE-AE-DATA\Graphics\JuiceCo\601_carrot juice_Clean.pdf	8/31/17 4:47 PM
607_mango juice.pdf	Optimize and Clean (PSFix)	0%	Reading \\leaw16dl267\WDE-AE-DATA\Graphics\JuiceCo\607_mango juice.pdf	8/31/17 4:47 PM
607_mango juice.pdf, 601_carrot juice.pdf, 600_banana juice.pdf	Optimize PDF Separations	61%	Saving Document	8/31/17 4:47 PM
607_mango juice.pdf, 601_carrot juice.pdf, 600_banana juice.pdf	Workflow	0%	Running	8/31/17 4:47 PM

1. Each task type or workflow control has its own way of attributing tokens:

- This workflow is launched on 3 input files. The step **Start** always attributes them the same token and so hands them over to the next step(s) as one group containing of 3 files. See how selecting one of them in the widget (dark blue) also highlights those that have the same token (light blue).
  - The workflow splits off into 2 steps that process this group differently: The step **Optimize PDF Separations** only shows one icon of a token , while the step **Optimize and Clean (PSFix)** shows 3 such tokens. This different behavior is decided in the software ; it is not a task setting you can change.
2. The list of **Tasks** shows how a task is started for each token.
  3. In the widget that shows the output of the **Optimize PDF Separations** task, selecting one of its items shows that the 3 output files are still grouped. They still have the same token. This type of task did not split the group: it keeps them grouped for a next step.
  4. In the widget that shows the output of the **Optimize and Clean (PSFix)** task, selecting one of its items shows that the 3 files are no longer grouped. This is because this type of task always attributes its output files an individual token: they will be handed over to a next step as separate items.



**Note:** An item in a widget is not always a file. It can also be a folder or even only some internal number.

### Controlling this grouping - Controlling how tokens are attributed

Sometimes you want control over these groups. You may want to change the built-in behavior.

Some examples:

- When you want separate files in stead of a group.  
For example: When your workflow starts with a Step & Repeat task.
- With this type of task, you will get this result by default:

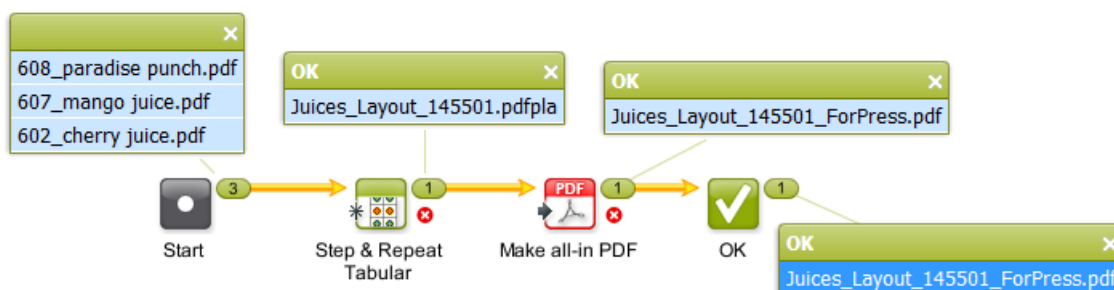

The S&R task here receives them as a group and so combines them on a same layout.

- If you do not want this (if you want a layout per input file), you can solve this by adding a **Data Splitter** in front:

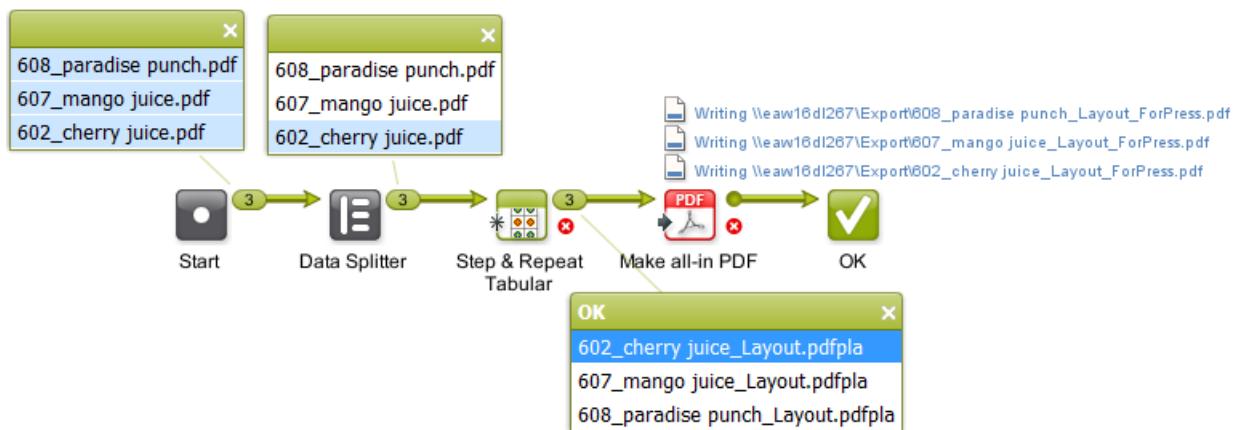

- When you want to overrule the built-in grouping logic.

Some examples:

- When you want specific grouping of RIP output files before they become input files for the task **'Prepare for Viewer'**. This grouping decides how the Viewer will open them.

Learn more in [Data Splitter](#).

- When you want to control which files should be ZIP'ped or FTP'd together.

Learn more in [Data Collector](#).

- When you want to collect files that were created from a source file in that workflow.

Learn more in [Fork and Join](#).

### About Empty Tokens

Automation Engine v18.1 started an important change in the behavior of AE workflows:

In case an output pin of a task or workflow control has no output file, a workflow can now continue with a so called 'empty token', where in previous versions, the workflow would have stopped.



This change was made to avoid that a workflow stops ('stranding') where it did not make sense to stop. Workflow steps that do not really need an input file, should not be blocked from starting when there is no such file.



**Attention:** This means that after an upgrade to 18.1, some workflows can now continue where before they used to stop. So check your workflows after this upgrade ; you might have to adapt some!

### 10.3.10. Searching Parameters in a Workflow

#### Concept

In the workflow editor's tool bar, click  to open the **Search** pane.

The search is done throughout the workflow, including sub workflows, but excluding referenced tickets.

The search is not case-sensitive.

When clicking on an item in the search results shown on the right, the corresponding workflow step is highlighted (even when it is part of a sub workflow).

See this example where the value of the sheet size was searched for:

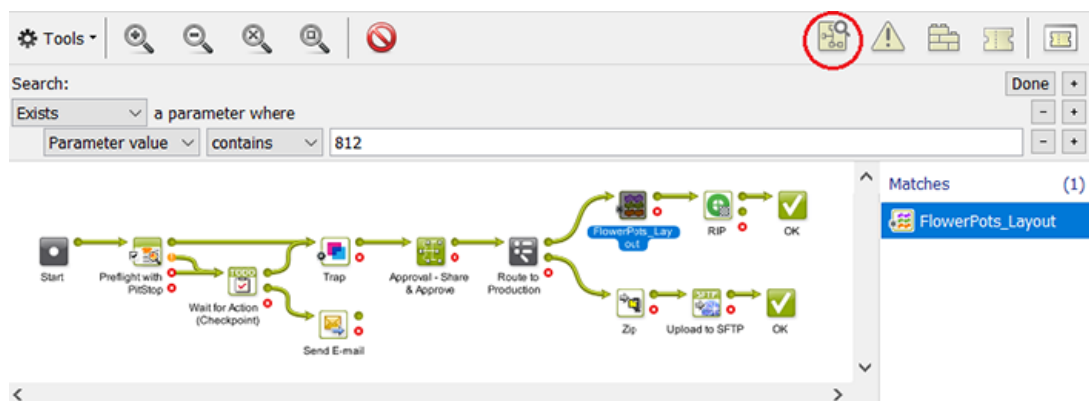

Double clicking a result will open that workflow step (ticket).

The list of results is live ; changes in the workflow are automatically reflected in the found results.

#### Search Types

You can search on

- **Task Type.** The name of the type of task. The search also checks the localized name: i.e. when you switched the UI to a different language.  
Example: Does my workflow contain 'classic' tasks?
- **Node Label:** The (customised) name of the workflow step, as it appears in the workflow editor.  
Example: In above screenshot, my workflow contain 'classic' tasks?
- **Parameter Name:** The name of a parameter in one of the workflow's tickets / steps.  
Example: Where in my workflow are trapping parameters?

When necessary (for example when it is an icon), find the exact name of a parameter by right-clicking on its value-field, then choosing **'Copy Parameter Name'** and pasting it in any text (editor) field to see its contents.

- **Parameter Value:** The value of a parameter in any step of the workflow. This could be a set of characters (number, text) or could be a selection from a dropdown list or could even be an icon (see an example of that below).

Example: Where does my workflow use XPath in values?

When necessary (for example when it is an icon), find the exact name of a parameter by right-clicking its value-field, then choosing '**Copy Parameter Value**' and pasting it in any text (editor) field to see its contents.



**Note:** As usual, this standard search tool can be extended with extra search rules. See some examples in this page about [The Tickets View](#) on page 129.

### How to search for Names or Values that are not standard Characters

When the value (or name) of a parameter is not an obvious set of characters but for example an icon or an item in a drop down list, follow these extra steps:

1. Go to an example ticket / step with an example of that parameter value that you want to search for. In this example we are looking for the value of the icon that specifies this type of filling order:

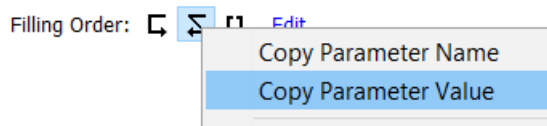

2. In that parameter value field or icon, right-click and choose '**Copy Parameter Value**'.
3. Then paste it in any text field (for example in a basic text editor application) to reveal the actual characters that you can use for this search tool.

In our example, the search string we need for that *value* appears to be `zigzag` (as an extra example, we also here pasted the *name* of that parameter '`SequencePattern`').

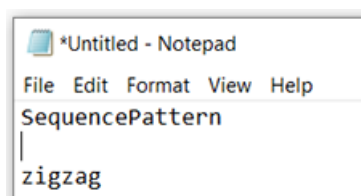

**Important:** This method also works to search for a SmartName. However, we advise to use the **Resources** pane to search for SmartNames in your workflow. Learn more in [Checking the Resources your Workflow contains](#) on page 803.

## 10.3.11. Checking a Workflow's Warnings

In the workflow editor's tool bar, click on  to open the pane that lists warnings related to this ticket.

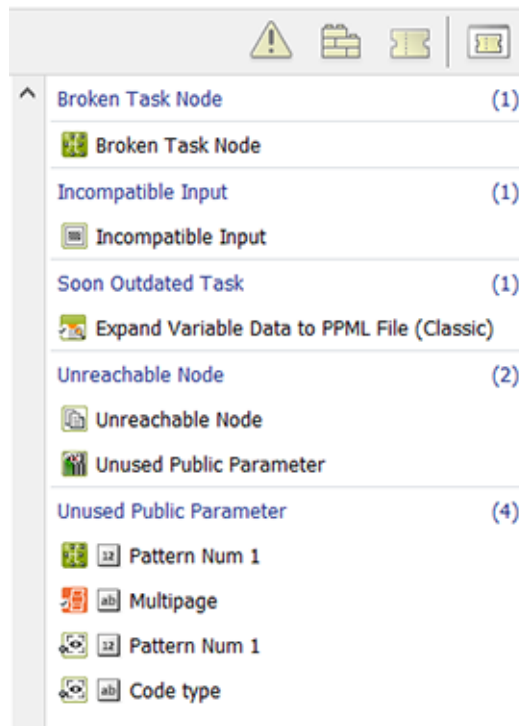

When you select a warning the corresponding step in the workflow is made visible, highlighted and stay selected. When it is part of a subworkflow, the subworkflow will open.



**Note:** This list is live. When changes are made to the workflow, the warnings are automatically updated.

Warnings are listed per type:

- **Broken Task Node:** This step is added as a reference but the referenced ticket is no longer available. This type of warning is not checked live ; it is only done when the workflow is opened.
- **Incompatible Input:** This step can not process any of the file types that the previous step can produce.
- **Soon Outdated Task** and **Outdated Task:** Learn more in [Concept of \(Soon\) Outdated Tasks / Features](#) on page 531.
- **Unreachable Node:** There is no transition (green arrow) going to this step in the workflow. You can remove this step from the workflow from within this warnings panel (use the classic shortcuts or **Right-click > Delete**).
- **Unused Public Parameter:** This parameter is made public in some workflow step (ticket), but it is not used in the list of [public parameters](#) of the containing workflow.

You can remove this step from the workflow from within this warnings panel (use the classic shortcuts or **Right-click > Delete**). This is an important tool to reduce the [size of a ticket](#).



**Tip:** An example of an unused public parameter:

- A workflow's list of public parameters shows that the 4 parameters of the step 'Prepare Graphics for nesting' that were made public (middle pane) are also really used (right pane).

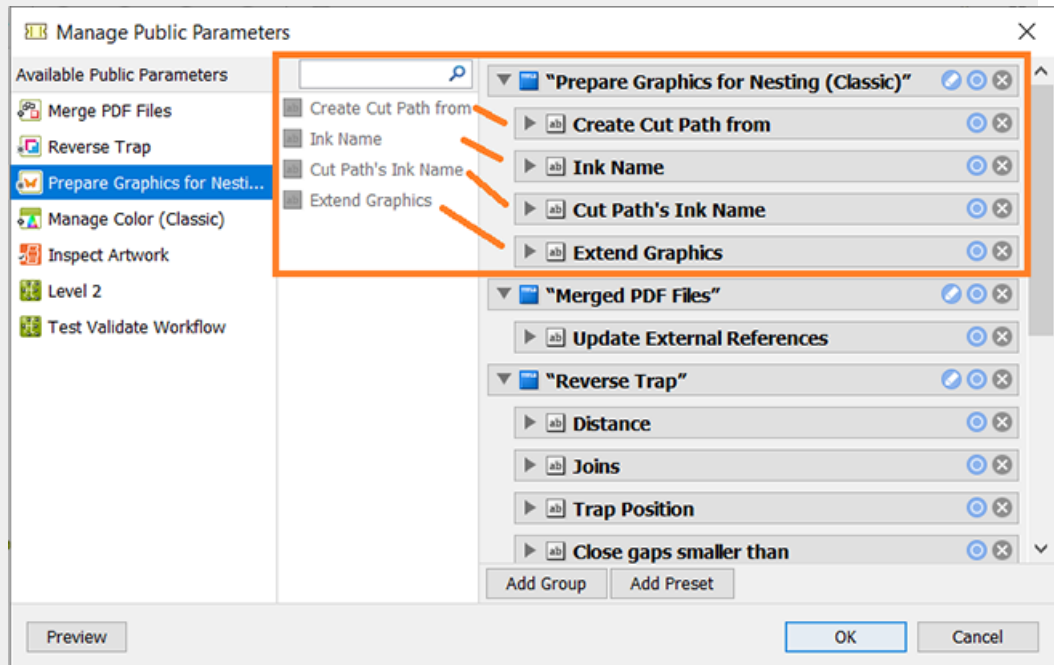

- After removing the parameter 'Extend Graphics' from the right side pane, it still shows in the list in the middle, but this time it is no longer greyed out. This indicates that this public parameter is still present in the workflow, but unused:

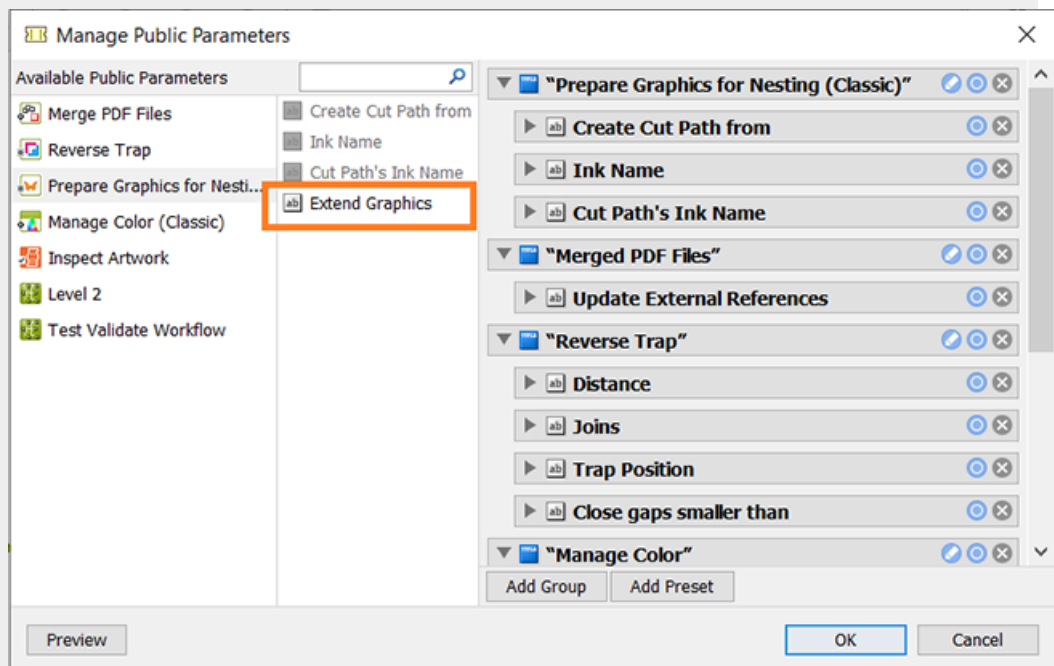

So instead of analysing this list of public parameters, this list of warnings makes it easier to find and delete unused public parameters.





**Note:** This list does not show unused public parameters in *referenced workflows*.



**Note:** Unused **workflow** parameters are not shown in this list of warnings. However, workflow parameters from subworkflows, if they are unused and they are public parameters, will be shown in this list.

- **Classic task.** Task types that use *classic technologies* can also easily be detected with this tool.

### 10.3.12. Checking the Resources your Workflow contains

#### Concept

In the workflow editor, the **Resources** pane allows to show and search the resources in your workflow. Click to show or hide this pane.



**Note:** This resources pane is also available when you open a workflow in the **Tickets** or the **Tasks** view.

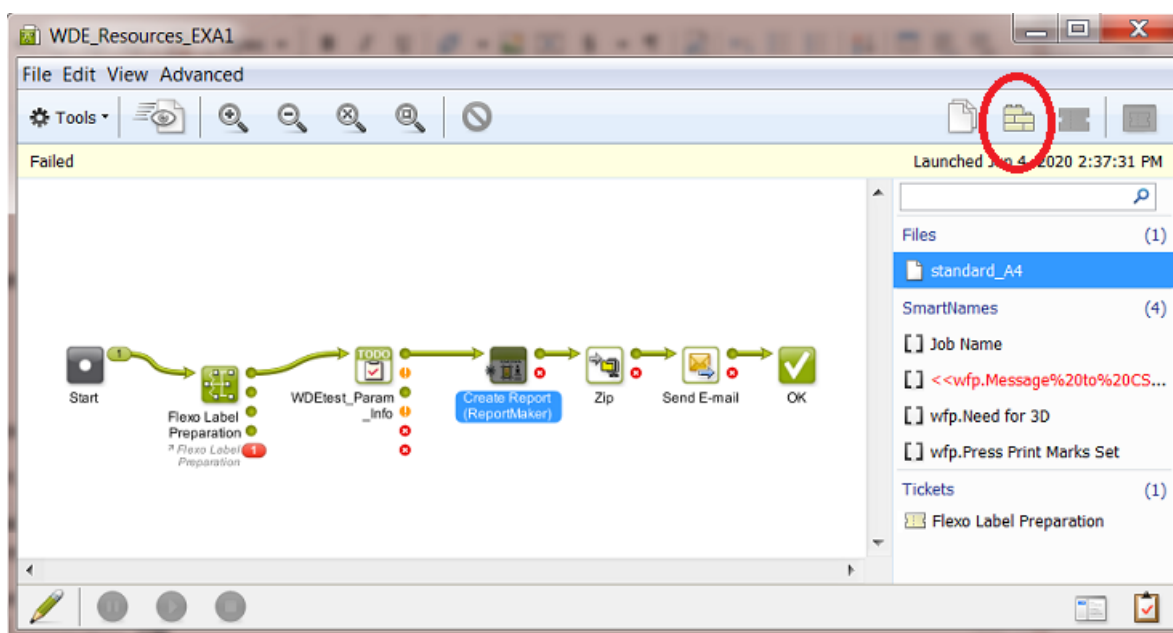

A workflow can use many different kind of resources. This tool can detect these resources:

- Files
  - Create Report (ReportMaker) template file. In above example, this is the template file used in the ReportMaker step.
  - Create PDF Report template file.
- SmartNames
  - All types, including public parameters, workflow parameters, ...
  - Workflow parameters appear in red when they are requested in a ticket but missing in the list of workflow parameters of this workflow.
- *Referenced* workflow tickets

- Marks sets
  - Dynamic Marks
  - SmartMarks
- Action list files
  - PDF Action List
  - ArtPro Action List
  - PitStop Profile
  - PitStop Action List
- CAD resource files
  - CAD Style
  - CAD DXF Tune
  - CAD Tune
- GlobalVision inspection tasks resource files
  - Compare Barcode Profile
  - Braille Language
  - Spelling Language
  - Compare Artwork Profile
  - Compare Text Profile
- Other resource files
  - Notification Template
  - Script files (.bat, etc.)
  - Tiling Template
  - Cutting Flow
  - Print Rule Set

### Using the Resources pane



- When a same resource is used in several workflow steps, for example a SmartName, it will also be listed several times.
- When you select a resource, the workflow step where it is used is also selected and scrolled into view.
- When you click on an already selected resource, an animation draws extra attention to the workflow step where it is used.
- When you double-click a resource in the list, the workflow step where it is used is opened and ready to be edited.
- SmartName parameters that are missing within this workflow appear in red, typically <<pp . or <<wfp . parameters.
- Use the filter in the resources pane to filter the list of resources. The entered text will be looked for in the resource name, resource category. For SmartNames it also takes the ID of the SmartName into account.

This helps to quickly answer the FAQ "Where is SmartName <<xyz>> used in this workflow?"

- When changes are made to the workflow, the list of resources is immediately updated to reflect the new situation.
- You can edit custom SmartNames directly from within the resources pane. Right-click the SmartName resource and select **Edit SmartName....** You can edit and save the SmartName in that dialog.

### 10.3.13. Pausing or Cancelling Your Workflow











While monitoring your file's progress in the workflow editor, you can:







- click  to pause your workflow (at the end of the task that is currently running),
- click  to make your paused workflow run again,
- click  to cancel your workflow's processing.

## 10.4. Workflow Controls

---

Workflow Controls are steps in a workflow. Instead of executing a task on an input file, they make workflow decisions on routing, file selection, file order etc.

-  **Start:** Every workflow needs to start with this step. By default it is present on every new workflow canvas.
-  **Modify Workflow Parameter Values:** Use this to modify workflow parameter values at some point during the workflow. Learn more in [Modify Workflow Parameter Values](#) on page 808.
-  **Select Referenced File:** Use this to easily select files that are referred to in an XML file. Learn more in [Select Referenced File](#) on page 821.
-  **Set Priority:** Use this to assign a different priority to parts of your workflow. Learn more in [Set Priority](#) on page 824.
-  **Sort:** When the order of the input files is important in the next workflow step, use this one to manage that order. Learn more in [Sort](#) on page 825.
-  **Router:** This step enables automatic routing of files based on many possible criteria. Learn more in [Router](#) on page 811.
-  **Mark File:** Use this step to mark files that you will select later in the workflow using the **Select Marked File** workflow control. Learn more in [Mark File and Select Marked File](#) on page 828.
-  **Select Marked File:** Use this step to select the files that you marked earlier in the workflow using the **Mark File** workflow control. Learn more in [Mark File and Select Marked File](#) on page 828.
-  **Data Splitter:** Use this step when you want to send the files one by one to the next task instead of grouped. Learn more in [Data Splitter](#).
-  **Data Collector:** Use this step to collect all incoming files before sending them to the next task as a group. Learn more in [Data Collector](#).

- 
**Fork:** Use this to tag incoming and related files with a group tag. This is useful in special cases where you want detailed control over how Automation Engine groups files in a workflow. Learn more in [Fork and Join](#).
- 
**Join:** Use this to select the files tagged as a group by the **Fork** workflow control. Learn more in [Fork and Join](#).
- 
**Cancel Workflow:** When a file is sent to it, this step cancels the processing of the entire workflow. This is useful when you also want to stop not just the branch of the workflow where this step is used, but all branches. For example: when the previous step **Manage Product Status** results in 'not approved' then the next step is **Stop**.
- 
**OK:** By default, there is already one **OK** step in the canvas. You can add more and route files processed successfully to the appropriate **OK** step. When a subworkflow ends with multiple OK's, they will show up in the master workflow as multiple green output pins.
- 
**Warning:** Add this step at the end of your workflow to route files that generated a warning during processing. For example preflight tasks or approval processes typically also offer a warning as end type.
- 
**Error:** Add this step at the end of your workflow to route files that generated an error during processing.



**Note:** A task that has one or more files ending with an error automatically triggers an error status for both that task and the whole workflow. That is why it is not necessary to add this **Error** workflow control and connect to it from the error output pin of a task.

To see which files caused this error, you can also click on the error output pin and open the output widget:



Learn more in [Diagnosing a Workflow in the Workflow Editor](#) on page 792.

### 10.4.1. Launch Workflow

#### Concept

Using this workflow control to launch workflows is only needed or advised in special circumstances, maybe also on the advise of Esko support.

This workflow control is not to be compared with adding a subworkflow in your main workflow (either as a copy or as a reference). The difference is that this workflow control launches the selected workflow in a 'fire-and-forget' mode (aka 'asynchronous').

This principle of 'fire-and-forget' means that the main workflow (the one that contains this workflow control as a workflow step) will

- not wait for nor collect any outputs of the workflow that this workflow control launches. This workflow control will also not have any output files, only an empty token.
- not check any execution statuses of the workflow launched with this workflow control.

This allows the main workflow to immediately continue with any other workflow steps.

Launching workflows with this tool is a good idea if you struggle with large workflows that result in too much unnecessary load on your system. Using this tool will then have a positive effect on your system stability.

The disadvantage is of course the 'forget' part: there is no tracking nor trace of what was launched with this tool.

For example, in the Tasks view, this step (just like all workflow controls) is not shown as a task step of the main workflow:

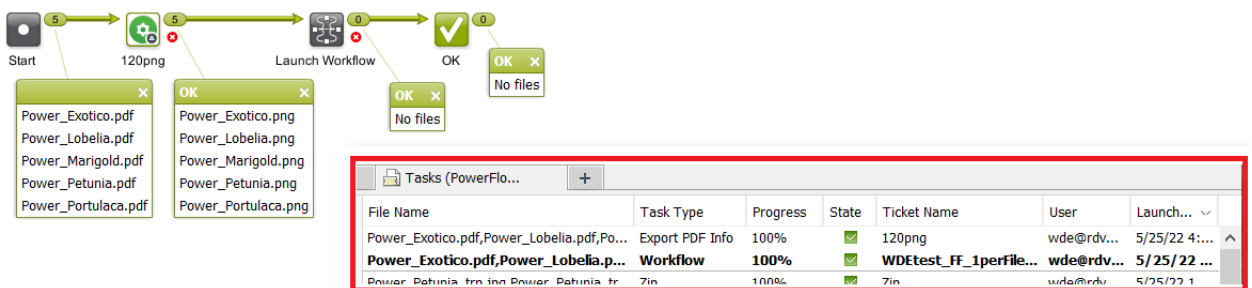

### Settings

- **Workflow:** Select the workflow ticket that you want to launch in this mode.
- **Launch a separate workflow per input file:** When selected, a separate workflow will be launched per input file.



**Note:** This effect of this option can not be seen visually, neither in the Workflow Editor nor in the Tasks view.

### Technical Details

- As soon as the selected workflow was launched successfully, an empty token will *instantly* appear on the **OK** output pin.
- When the selected workflow encountered errors while being launched (for example a SmartName that can't be resolved), the input files will be placed on the **Error** output pin.
- When using a SmartName for the name of the workflow to launch, be aware that this field is only calculated once. So if it is needed to calculate this SmartName per input file, you need to use the Splitter workflow control as the workflow step before this one.
- The selected workflow is always run without any Job context, even when the main workflow was run in a Job context. This means that you can't use Job-related SmartNames inside that workflow.
- When the here launched workflow has a value for a workflow parameter, it will be overruled by the value of that same workflow parameter that is set by the main workflow at the moment this workflow control starts.
- The selected workflow is always launched with priority 'Normal'.

- This workflow control requires some kind of input file (a non-empty token).

## 10.4.2. Modify Workflow Parameter Values

This workflow control allows to modify values of workflow parameters during the workflow. Learn more about workflow parameters in [Using Workflow Parameters](#) on page 859.

### Concept

The typical reason to modify a workflow parameter during a workflow is that there is new or changed information that was not there earlier or at the start of that workflow. Some example cases:

- The new or changed information is based on a user's decision. For example the decision how to release a to-do item. See an example below.
- The new or changed information is coming from an external system (and was not available earlier).



**Note:** Mind these exceptions:

- New information coming from WebCenter does not need this separate workflow control. The tasks that communicate with WebCenter offer their own built-in tool to map their output parameters to workflow parameters. Learn more in [Modifying Workflow Parameters During a Workflow](#) on page 870.
- When, during a workflow, an external system sends an updated XML with new or modified parameters, check if you can use the feature [Using Workflow Parameter Values from XML](#) on page 866. This feature loads that XML at every step of the workflow, not just at the start. This means that the incoming updated XML can trigger an updated workflow parameter without the use of this separate workflow control.

### Using the workflow control 'Modify Workflow Parameter Values'

To use this workflow control, proceed as follows:

1. Select and drag the **Modify Workflow Parameter Values** workflow control onto your workflow canvas. Double-click it to edit.
2. Click **Add** to add workflow parameters or double-click existing ones to modify.
3. Use  to select an existing parameter or type the desired workflow parameter name and provide a new value. This can be a fixed value, a SmartName or an XPath expression that retrieves the new value from the workflow control's XML input. Learn more on XPath in [The XPath Builder](#) on page 678.

When the input file is a JSON file, you can here also enter a **JSONPath** expression. Learn more in [JSONPath Expressions](#) on page 810 .



**Attention:** As mentioned in [The XPath Builder](#) on page 678 , adding SmartNames or JSONPath expressions to your XPath expression is not supported when you are creating this kind of an 'inline' XPath expression.

4. Click **Add** to confirm.



**Note:** When the parameters list contains a new one, you will be asked to **Confirm**.

5. Click **OK** to close. Save your workflow.

**Example: Capturing the To-Do decision as a Workflow Parameter**

Our workflow asks a user to decide if the output will be done on the old or on the new printer. This decision should also be mentioned on the Report PDF.

- See how the Checkpoint task output Pin 'New faster Printer' routes to the workflow control that sets the value of the workflow parameter 'Printer Decision by User' to 'New Faster Printer'.

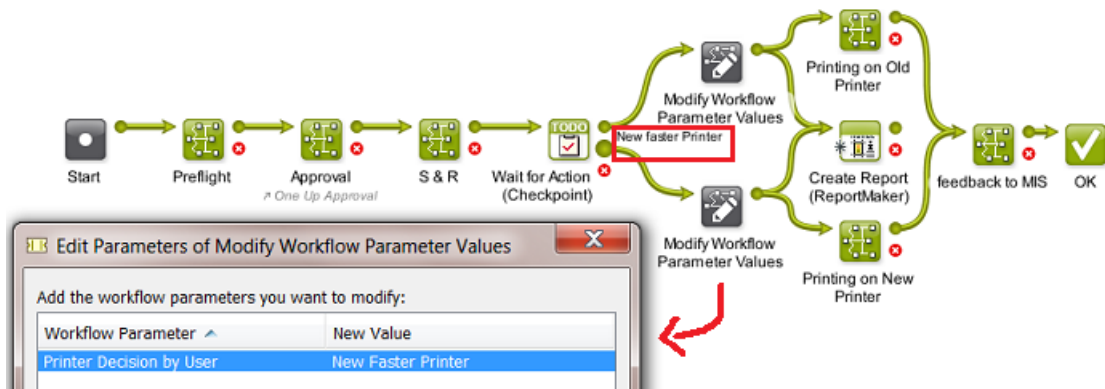

- The ReportMaker template needs to pick up that workflow parameter. Those templates are created in PackEdge. Because PackEdge SmartMarks can not pick up workflow parameters, you first need to create a SmartName of that workflow parameter and then use that SmartName in the template. Follow these steps to do this:
  1. In Pilot, in the SmartNames View, in **Include SmartNames From**, check the option **A workflow** and select the workflow that contains the desired workflow parameter.
  2. Click **[ ]** to create a new SmartName.
  3. Set the Scope to **Global** and the SmartName Type to **String Extract**.
  4. Click **+ [ ] Insert SmartName** and select the category **Workflow Parameters**.
  5. Select the desired workflow parameter [wfp. ] and click **Insert**.
  6. Save the SmartName.
  7. Open the ReportMaker template in PackEdge and open the **SmartMark** palette.
  8. Select **Text Mark** from the **Add SmartName** palette.
  9. Click the **Smart Text...** button, select the category **SmartNames (Global)** and select the SmartName you just created.
  10. Save the ReportMaker template
  11. Use this template in the ReportMaker task. The resulting PDF can now mention what the user decided in his to-do item. Here is an example of how this can look like:



**Visualizing the Workflow Parameter Values of a Step Output**

To visualize the Workflow Parameter Values of a selected file, you can:

- choose the menu item **Advanced > Workflow Parameter Values**. This dialog stays opens while you click on output files.

- right-click on the desired step output and select **Workflow Parameter Values**.

Using above mentioned example, see the workflow parameter values of the Report PDF. The small icon  indicates that the value was modified during the workflow:

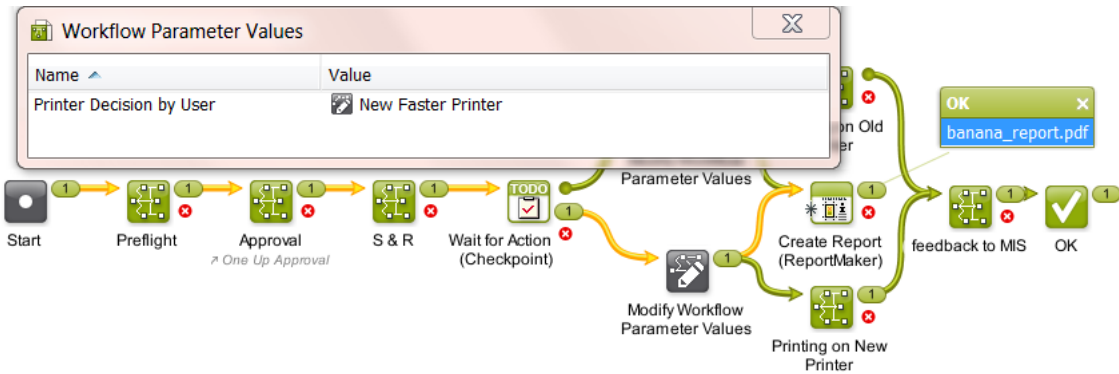



 **Note:** The set of workflow parameters can be different for each step output. For more info, see [Using Workflow Parameters](#) on page 859.

## JSONPath Expressions

### Concept

When the input file is an XML, you can directly type in an XPath expression in some fields of the task's options. Those fields also offer to click on  to open a panel to help you build that XPath expression with the correct syntax.

In the exact same way, when the input file is a JSON file, you can there type in a JSONPath **Expression**. And when you click on , the same panel opens to help you build that JSONPath Expression.

 **Attention:** This button is not available in all tasks. It is only available in these workflow controls: [Modify Workflow Parameter Values](#), [Select Job](#) and [Select Referenced File](#).

Learn all about this panel that helps you build JSONPath expressions in [The XPath Builder](#) on page 678. Its features are equally valid for JSON data.

 **Note:** Unlike XPath, it is not possible to create JSONPath SmartNames.

### Example



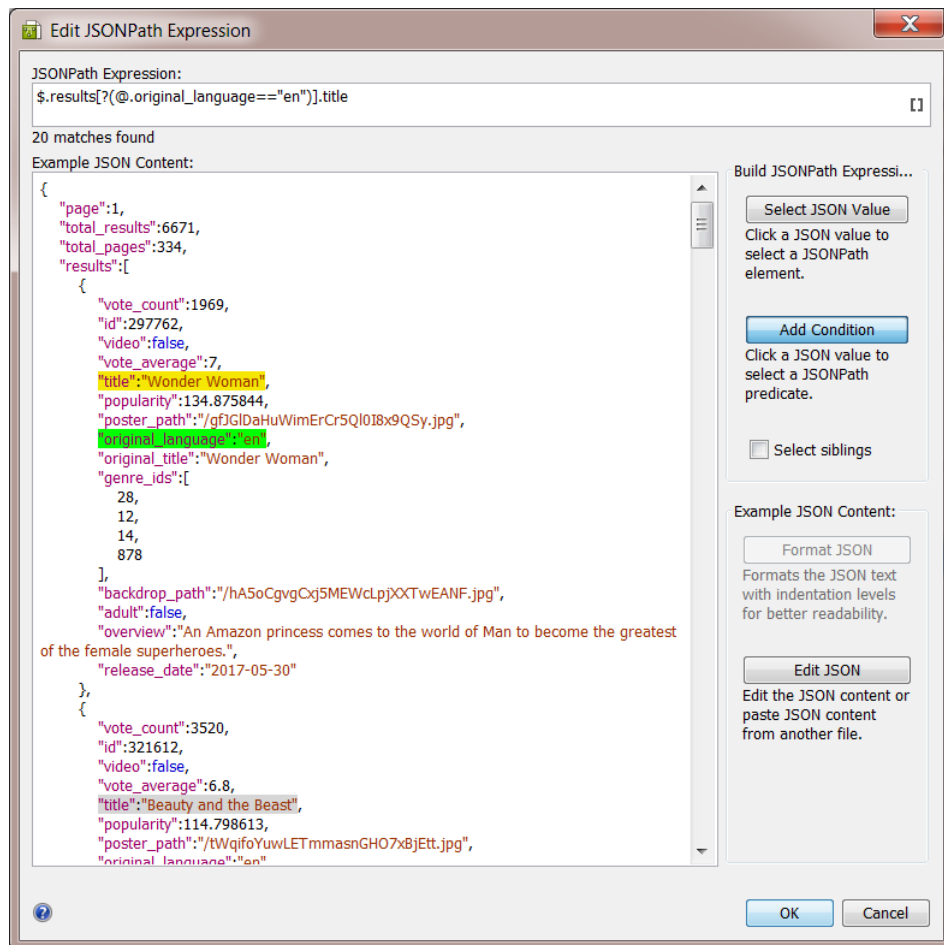

### 10.4.3. Router

The **Router** workflow control  serves to automatically decide the route that your workflow (files) should follow.

Let's take the example where a Router decides the workflow track based on the size of the incoming file. When the file is smaller than 5 MB, the file will be sent out via E-mail, otherwise via FTP.

- These are the settings in the Router:

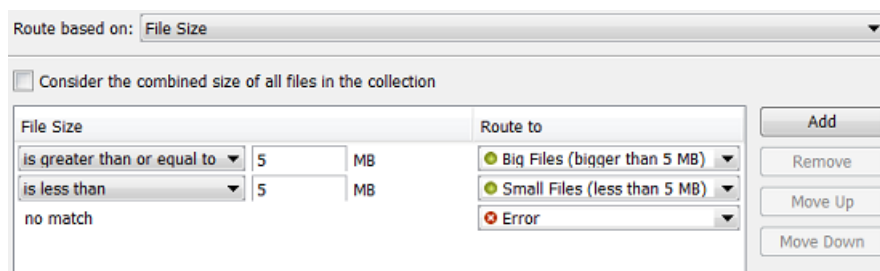

Two rules were defined and the **Route to** names were customized.



**Note:** The rules are executed from top to bottom. Their order can be changed with **Move Up / Move Down**.

- This is the workflow:

Notice how (when the mouse hovers over the Router step) the name of the middle output pin appears and how it matches the name that was defined in the **Route to** column of the Router settings.

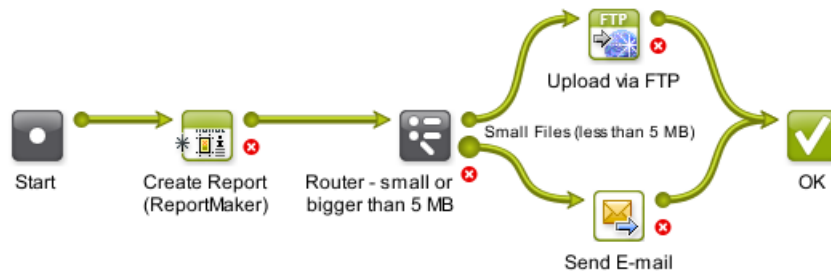

Routing can be based on many different criteria (see the list below). Several of them offer these generic options:

- **Treat as numeric value:** When you select this, the options in the **value** column offer numeric possibilities (is less than, is greater than, etc.). This option is not there when it is obvious that the value is numeric.
- **Case sensitive:** Select this if you want to match the exact case of the value.



**Note:** If a value has to **match**, wildcards and *Regular Expressions* can be used in the value field.

### Routing Based on Job Parameter Value

Choose this to route your file based on a Job Parameter. The **Parameter Name** drop-down list offers the parameters of the Job setup tab **Parameters** and also those of the tab **Step&Repeat**.



**Note:** You can also type in the parameter. This is not advised to avoid typing errors. However this can be useful when you build the workflow and router settings outside of a Job context in which you will be using it. In that case the parameters will not show up in the drop-down list yet.

An example:

Route based on: Job Parameter Value		
Parameter Name: Trapping needed		
<input type="checkbox"/> Treat as numeric value	<input type="checkbox"/> Case sensitive	
Job Parameter Value	Route to	
contains yes	Trapping needed	Add
contains no	No Trapping needed	Remove
no match	No Trapping needed	Move Up
		Move Down

Notice how you do not always need an Error route and how same routes can be chosen for more than 1 value.

### Routing Based on Job Field Value

Choose this to route your file based on one of the Job setup fields listed in the **Field Name** drop-down list. The list also includes the custom **Job Categories** you may have defined.

The field **Job Operation Context** can only have these 2 values: `update` or `creation`. This value was useful in cases where we now advise to use the **Create Job** task as a workflow step. Learn more in the [Advanced](#) tab of that task.

### Routing Based on Number of Files

Choose this to route collections of input files based on the number of files in that collection.

Some examples:

- When you get not 1 but 2 files, you want to route to the recto/verso (front/back) workflow.
- You created various **Tabular Step & Repeat** tickets, one for each amount of **Grids** that they offer. You use the Router to route to the Step & Repeat ticket with the same number of grids as the amount of input files.

### Routing Based on Milestone

Choose this to route based on the fact if a certain Milestone is **Set** or **Not Set**.

For example: you have a workflow where someone from the administration department uses the Pilot to select a Job and set the Milestone 'OK from Admin department to Print'. The Router checks if this OK was already given before continuing the workflow to the press.

The screenshot shows a configuration window for routing based on a milestone. At the top, a dropdown menu is set to 'Route based on: Milestone'. Below it, another dropdown is set to 'Milestone: OK from Admin Department to Print'. The main area contains a table with two columns: 'Milestone' and 'Route to'. There are three rows: the first has 'is' and 'Set' leading to 'Print workflow'; the second has 'is' and 'Not Set' leading to 'Wait for 1 hour and check again'; the third has 'no match' leading to 'Error'. To the right of the table are buttons for 'Add', 'Remove', 'Move Up', and 'Move Down'.

Milestone	Route to
is Set	Print workflow
is Not Set	Wait for 1 hour and check again
no match	Error

### Routing Based on File Name

Choose this to route files based on their name. Choose to **Include the file extension** or not.

For example: You agreed with the person sending you design files that no trapping will be done if he ends the file name with 'notrap'. You created an Access Point that launches a workflow that starts with this Router:

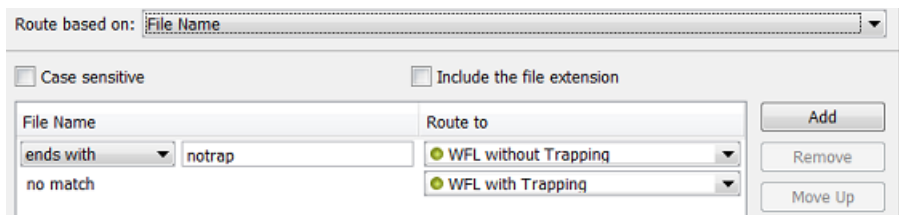

### Routing Based on File Type

Choose this to route files based on their type.

For example: this Router categorizes many file types into specific routes:

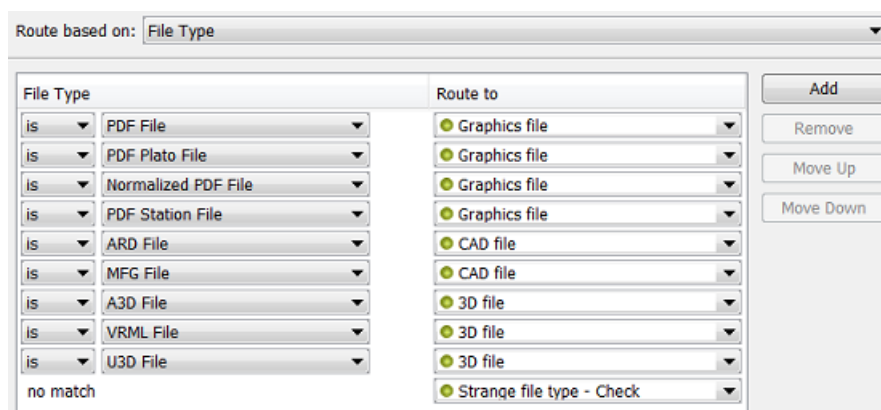

### Routing Based on Template Type

Choose this to route PDF files based on what type of template they are.

You may want to detect if an incoming PDF file is a Report Template or a VDP Template or no template at all (a one-up or a layout PDF for example).

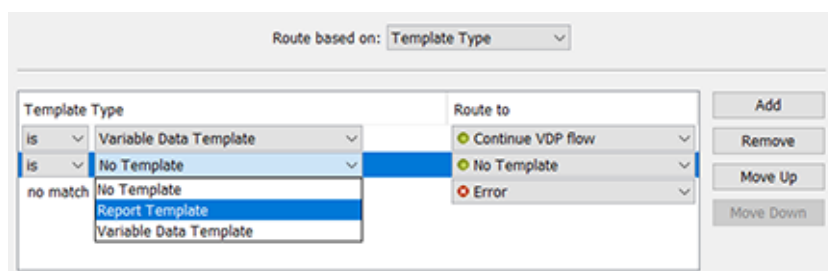

What type of template a PDF is also shown in its file **Info** dialog.

### Routing Based on File Size

Choose this to route files based on their size.

Select **Consider the combined size of all files in the collection** if you want to match the size of the whole file collection and not of its individual files.

See an example in the above introduction.

### Routing Based on Number of Pages

Choose this to route files based on their number of pages.

Select **Consider the combined page count of all files in the collection** if you want to match the page count of the whole file collection and not of its individual files.

For example: if the file has 2 pages, then you know it is a recto/verso (front/back) file.

### Routing Based on Page Orientation

Choose this to route files based on their orientation (**Portrait, Landscape or Square**).

Some examples:

- your RIP does not have an auto-rotate function. Your workflow will then need to make sure that you send the data in the wanted orientation.
- you want to know if a file fits on an output sheet. Before you compare the sizes, you will want to know which side is the longest. If your output sheet is 100 horizontal by 60 vertical, you best only compare sizes when your input file is also in landscape mode.

### Routing Based on Page Size

Choose this to route files based on their page size.

In **Pagebox to use**, you can choose either **Trimbox** or **Mediabox**. For images, both settings Trimbox and Mediabox will have the same result. The image size will be used for the comparison.

This is typically used to route files to the output device with the right size. For example to send small files to the small proofer, and bigger ones to the big proofer.

An example: When you want to route a file to a right printer:

- When a file fits on A4 paper = "is less than or equal to 210x297 mm"
- When a file fits on A3 paper = "is less than or equal to 297x420 mm"

Note that router entries have an order. In above example, a 100x100 mm file both fits A4 and A3 paper, but A4 is chosen because it comes first in the list of criteria.



**Attention:** Both page orientations of the input file are always checked! The page size that you here define is the size of a surface that the file can fit in or not, no matter how it is orientated.

"Is less than or equal to" means "Does the file fully fit in the specified surface (in portrait **or** landscape)?"

"Is greater than" means "Does the file fully cover the specified surface (in portrait **or** landscape)?"

For example: 'Page size' is equal to '210 x 297 mm' will therefore match A4 files both in portrait and landscape mode.

### Routing Based on Number of Separations

Choose this to route files based on their number of separations.

For example: when a flexo job has more than 6 inks, you use a different SmartMarks set. It then uses one with smaller rectangles for the color strips. You use a Router that checks the number of separations. If it detects more than 6 inks, the next step is the Step & Repeat ticket that uses the set of SmartMarks with the smaller rectangles.

Select **Consider the combined separation count of all files in the collection** if you want to match the number of separation of the whole file collection and not of its individual files.



**Note:** This counts the number of **unique** separations. For example, if you have a CMYK+Red and a CMYK+Green file, the collection's combined separation count will be 6.

### Routing Based on Separation Name

Choose this to route files based on the name of their separation(s).

You can check if **any** (one or more), **all** or **none** of the separation names match or contain parts of a specified string.

For example:

- when 'any' separation names 'contain' the text string 'pantone', then route to the part of the workflow where you process the files that are not CMYK-only.
- when 'all' separation names 'does not contain' the text string 'Die', then route to the **Checkpoint** task that will add an Action to the To Do List. The Action will ask the user to add that separation.

### Routing Based on Layer Name

Choose this to route files based on the name of their layer(s).

For example: you sometimes receive PDFs with several layers of black text in different languages. The Router checks if the file has any layers with these names: FR, SP, EN, DE, IT, or PT. If so, it routes them to the workflow where you first use **Version PDF** to create PDFs with only 1 language in black (k): name\_cmy\_FR\_k.pdf, name\_cmy\_SP\_k.pdf, etc.

You can check if **any**, **all** or **none** of the layer names match. When using **any**, only one layer name needs to match for the file to be considered matching.

### Routing Based on SmartName Value

Choose this to route files based on a SmartName value.

For example: the Router checks the workflow parameters 'Print Process' or 'Preflight Yes or No'. The values of these parameters decide what route the file needs to follow.

Find a good example in [Launching a workflow with parameters from an XML](#) on page 1889. Step 5 of that example illustrates how the Routers use SmartNames.

**Note:**

Routing on SmartNames requires more resources from Automation Engine. If you have an alternative, we advise you to use another routing method instead.

If your SmartName only contains **Job** related parameters, and you have many input files, we advise to add a [Data Collector](#) in front of your **Router**. This will group the files into a collection and allow the Router to perform the SmartNames check only once.

### Routing based on XPath

Use this when you have an XML file that contains a value that you want to route a workflow on.

When routing multiple files, the expression is calculated per input file.

To get help to specify the correct expression, click **Edit** to open the editor.

Learn about XPath expressions in [The XPath Builder](#) on page 678.



**Note:** Using SmartNames is not supported with this type of routing.

### Routing based on XMP XPath

Use this when you want to route a workflow on a value that is part of XMP metadata inside the (PDF) input file.

Learn about XMP XPath expressions in [XMP XPath Query SmartNames](#) on page 682.

Learn about XPath expressions in [The XPath Builder](#) on page 678.

To get help to specify the correct expression, click **Edit** to open the editor.



**Note:** Using SmartNames is not supported with this type of routing.

### Routing based on JSONPath

Use this when you have a JSON file that contains a value that you want to route a workflow on.

This avoids having to create extra JSONPath SmartNames or to create many workflow parameters.

Learn about JSONPath expressions in [JSONPath Expressions](#) on page 810.

To get help to specify the correct expression, click **Edit** to open the editor.

The [XPath Builder](#) then also functions as a JSONPath builder.



**Note:** Using SmartNames is not supported with this type of routing.

## 10.4.4. Select File

This task allows you to select one or a group of files on which you launch the next workflow step.



**Restriction:** In an [AE SaaS setup](#), this task will, for security reasons, not be allowed to select files that are not inside a Container of this AE server. When the task's settings require this anyway, the task will fail. Also the task [Copy or Move file](#) follows this restriction.

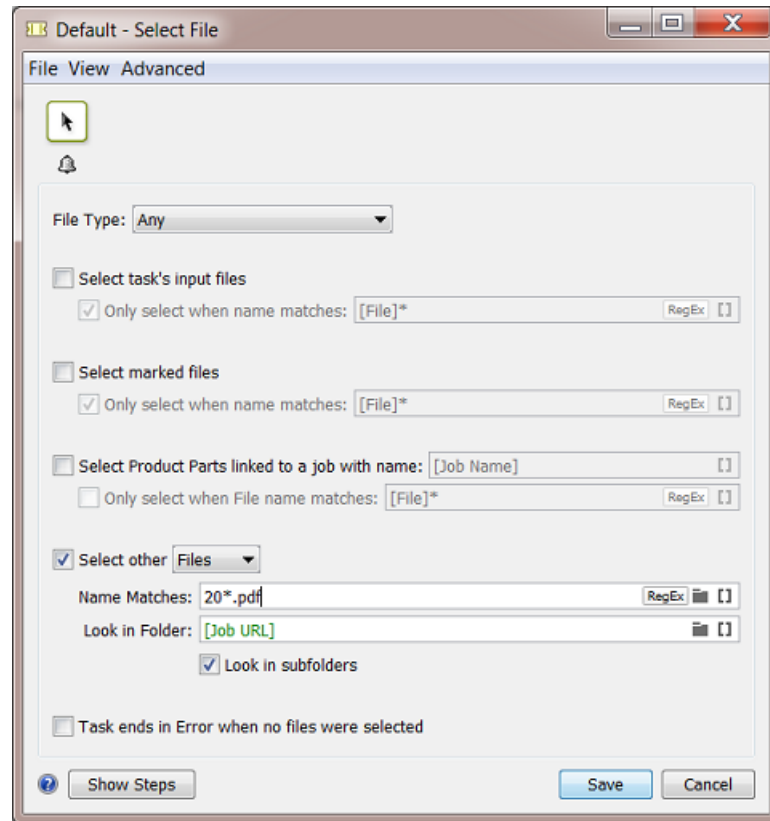

**Note:** In an input field, when the matching icon is present, you can use SmartNames or *Regular Expressions* or browse to define a folder. You can also use \* as wild card character.

1. Define what file types you want to select in the **File Type** list. You can:
  - choose to select **Any** file type,
  - pick one of the default file types,
  - choose **Select File Types** and pick them in the **Select File Types** dialog.
2. Define which files you want to select:
  - **Select task's input files** will select all input files (of the selected **File Type** if you specified one).  
Use the **Only select when name matches** option if you want to filter the input files to select based on their name.
  - **Select marked files** will select files you have marked earlier in the workflow (using the **Mark File** task).  
Use the **Only select when name matches** option if you want to filter the marked files based on their name.
  - **Select Product Parts linked to a Job with name** will select Product Parts linked to a job of your choice. Specify the job name in this option.  
Use the **Only select when File name matches** option if you want to filter the Product Parts based on the name of the file they contain.



- See the chapter [Products](#) on page 594 more information about Products and Product Parts.
- **Select other** will select other files or folders (that have not been processed by the workflow).
  1. Choose to select **Files** or **Folders**.
  2. Use the **Name Matches** option to select those files or folders based on their name. This is not case sensitive.
  3. Define where the files or folders to select are located in **Look in Folder**. Choose to **Look in subfolders** or not.
- 3. If you want, you can choose to make the **Task end in Error when no files were selected**.

### 10.4.5. Select Job

The **Select Job** workflow control serves to select a job in a workflow. It actually selects the Job Folder. The next task in the workflow will use that job folder as input.

This workflow control is typically followed by a [Remove Job](#) or [Archive Job](#) task.



**Note:** The job context and any job related SmartNames in the following workflow will still be those from the job that the workflow was started in originally.

You can choose to select a job using the **Job name** or by using the combination of the **Order ID** and **sub order ID**.

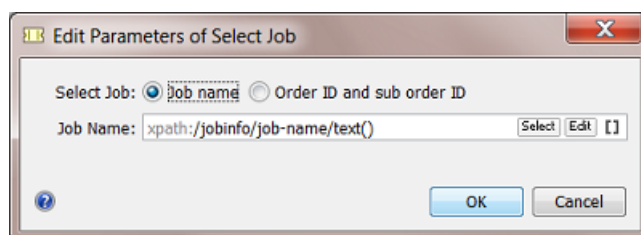

The **Job name**, **Order ID** and **sub order ID** can be specified by:

- Entering a value.
- Inserting SmartNames.
- Selecting a job using the **Select** button. The **Job name**, **Order ID** and **sub order ID** will then be filled in automatically.
- Entering an XPath expression. You can enter one manually or click **XPath** to use the **Xpath Builder** where you create an XPath expression that gets a value from an XML file. Learn more about creating Xpath expressions [here](#).
- When the input file is a JSON file, you can here also enter a **JSONPath** expression. Learn more in [JSONPath Expressions](#) on page 810 .



**Attention:** As mentioned in [The XPath Builder](#) on page 678 , adding SmartNames or JSONPath expressions to your XPath expression is not supported when you are creating this kind of an 'inline' XPath expression.



**Attention:** The **Select Job** workflow control only handles one input file at the time. When you want to select the jobs of multiple input files, you need to use a **Data Splitter** step in front of it.

### 10.4.6. Select Product

#### Concept

The **Select Product** workflow control is typically used in a workflow where the next step is to change the status of the selected product (part) or to remove the product.

It can select one or multiple products or product parts. Its outputs are the URLs of all parts of the selected products.

You can select a product by its **ID** or **Name** or select a **product part by its name**.

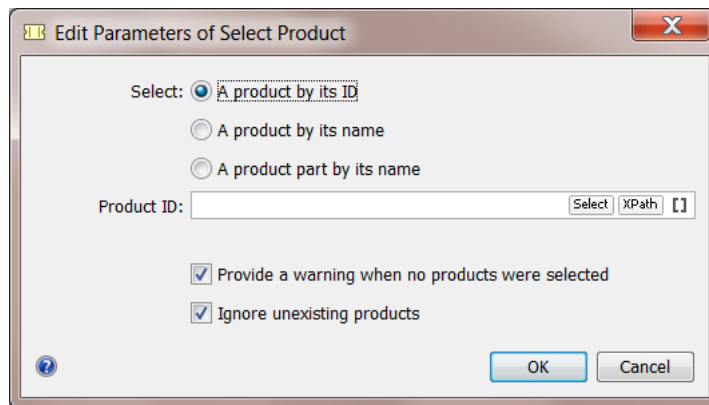

#### Ways to Identify the Product(s)

In the input field, you can type in values, **Select** a product from the list or use SmartNames.

You can also add an **XPath** expression, in which case the input file of this workflow control has to be an XML file. The XML file can be one with or without XML namespaces. Click on **XPath** to open the XPath Builder and select the XML value matching the product (part).

This is an example where the expression results in one value, the first one of that XML element. Notice the [1] in the expression:

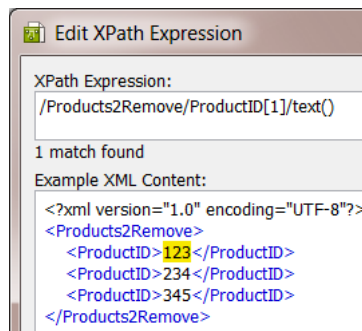

In this next example, the user manually removed the [1] in the expression and confirmed with **Enter** (or click **OK** and re-open the XPath Builder). You can see that the expression now selects **all** the values. In such a case, where the XPath expression resolves to a list of values, each individual entry in the list is used to select that list of products.

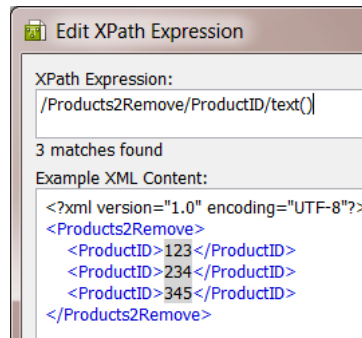

Learn more about the XPath Builder in [Creating XPath Expressions](#) on page 1835.

### Options

- **Provide a warning when no products were selected.** When no products were selected and when this option is not checked, there will be no warning status and the **OK** output pin will show zero outputs.
- **Ignore unexisting products.** When this option is enabled, products that do not exist in the database will not be selected. When this option is disabled, selection of an unexisting product will lead to an error.

## 10.4.7. Select Referenced File

Use the workflow control **Select Referenced File** to easily select files that are referred to in an XML file.

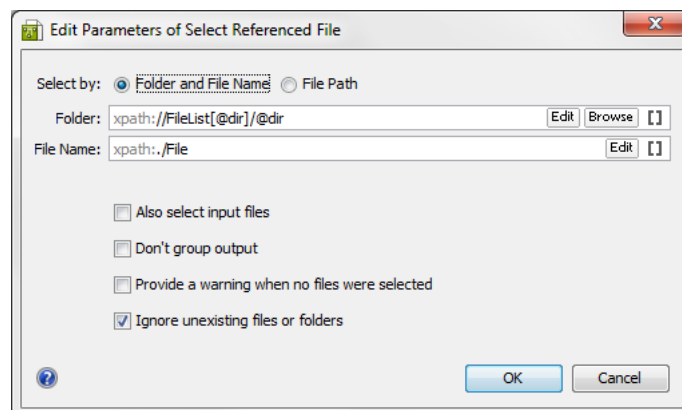



**Note:** The **XPath** button offers to use the **Xpath Builder**. Learn more about creating Xpath Expressions [here](#).

When the input file is a JSON file, you can here also enter a **JSONPath** expression. Learn more in [JSONPath Expressions](#) on page 810 .



**Attention:** As mentioned in [The XPath Builder](#) on page 678 , adding SmartNames or JSONPath expressions to your XPath expression is not supported when you are creating this kind of an 'inline' XPath expression.

- **Select by:** You can indicate (via SmartNames or XPath) which XML content to take to build up the corresponding file path(s) and name(s). You can choose between:
  - **Folder and File Name:** Choose this option if the source XML contains entries that define the file path and file name separately. If this option is chosen, specify both the **Folder** and the **File Name**.
  - **File Path:** Use this when each file in the source XML has a fully specified absolute file path.
- **Also select input files:** Select this option to also add the step's input file(s) to the group of output files.

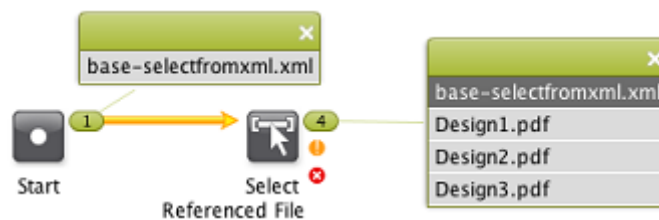

- **Don't group output:** When this option is selected, the selected files will be offered separately to the next step in the workflow instead of as a group.

When **Don't group output** is not selected (so output is grouped) and **Also Select Input Files** is selected, the task will generate a group for each output:

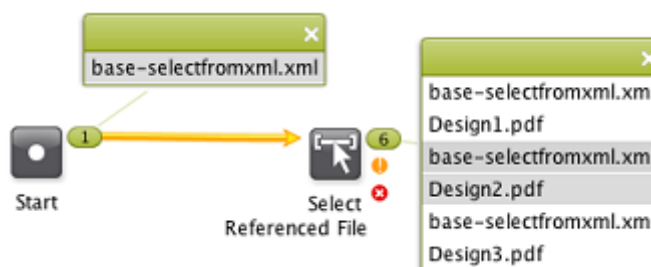

- **Provide a warning when no files were selected:** Select this option to get a warning when no files are selected.
- **Ignore unexisting file or folder:** Select this option to prevent workflow errors when one or more file paths refer to non-existing files. When selected, the non-existing files will be ignored.

### Example 1: Folder and File Name

Our example XML refers to one file in a first Job and then to 3 files in another Job:

```
<?xml version="1.0" encoding="UTF-8"?>
- <doc>
  - <FileList dir="file:///loppem/ExampleJobContainer/Orders/Order-2014-100024">
    <File>PDF/Design1.pdf</File>
  </FileList>
  - <FileList dir="file:///loppem/ExampleJobContainer/Orders/Order-2014-100025">
    <File>PDF/Design1.pdf</File>
    <File>PDF/Design2.pdf</File>
    <File>PDF/Design3.pdf</File>
  </FileList>
</doc>
```

We used the **Edit** button to get to these settings:

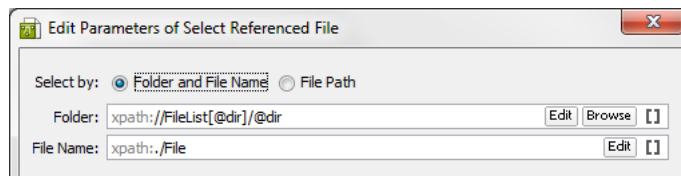

After the **Select Referenced File** step ran, you will notice these 4 files on the OK output pin of the workflow control (assuming the files exist).

- file:///loppem/ExampleJobContainer/Orders/Order-2014-100024/PDF/Design1.pdf
- file:///loppem/ExampleJobContainer/Orders/Order-2014-100025/PDF/Design1.pdf
- file:///loppem/ExampleJobContainer/Orders/Order-2014-100025/PDF/Design2.pdf
- file:///loppem/ExampleJobContainer/Orders/Order-2014-100025/PDF/Design3.pdf

### Example 2: Absolute File Path

This example XML contains several absolute file paths:

```
<?xml version="1.0" encoding="UTF-8"?>
...
<FileSpec>file:///AEServer01/Food/Orders/1234/PDF/design1.pdf</FileSpec>
<FileSpec>file:///AEServer01/Food/Orders/1234/PDF/design2.pdf</FileSpec>
<FileSpec>file:///AEServer01/Food/Orders/1234/PDF/design3.pdf</FileSpec>
...
```

We chose the option **File Path** and used the **Edit** button to get to this setting:

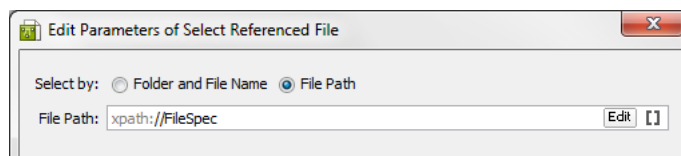

The output pin of the **Select Referenced File** step will show these 3 file paths:

- file:///AEServer01/Food/Orders/1234/PDF/design1.pdf

- file://AEServer01/Food/Jobs/1234/PDF/design2.pdf
- file://AEServer01/Food/Jobs/1234/PDF/design3.pdf

### Example 3: Using SmartNames

This example XML has a different structure:

```
<?xml version="1.0" encoding="UTF-8"?>
<Order id="2014-102457">
  <Customer id="JuiceCo"/>
  <Design>
    <File>PDF/design1.pdf</File>
    <File>PDF/design2.pdf</File>
  </Design>
</Order>
```

In this case, we find the Folder via a SmartName, based on the Order ID, and the File Name via an Xpath:

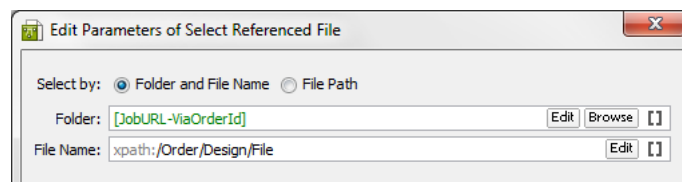

This is the resulting selection ; the part of the path including the Job number was found via the SmartName, followed by what the XML defined in <File> :

- file://AEServer01/Food/Jobs/102457/PDF/design1.pdf
- file://AEServer01/Food/Jobs/102457/PDF/design2.pdf

## 10.4.8. Set Priority

Use the **Set Priority** workflow control to assign a different priority to a part or a specific branch of a workflow.

You can set the priority to:

- **Workflow** (to use the general priority assigned to the workflow)



**Note:** By default, the general workflow priority is set to **Normal**. You can change it by going to **Advanced > Task Options...** in the workflow editor window.

- **Low**
- **Normal**
- **High**
- **Extra High**



**Attention:** This level of priority is different than the **'immediate'** one that a user can select in **Task Options** when he launches a task from the Pilot or browser client. Here, inside this step of a workflow, this maximum level of priority 'extra high' will not result in an immediate launch. Mind that this workflow control could be asked to set a priority for hundreds of **tokens** at once. To protect the stability and continuity of the workflow engine, you can here not request to have them all start immediately.



Set Priority

Priority: Low

The chosen priority is shown in blue right under the workflow control:

**Example**

In this example, the most urgent operation is RIP'ing the files and outputting them to the device. Creating a PDF report or a JPEG is less urgent. All the workflow steps following the "Set Priority" step will get this high priority, that whole workflow branch:



**10.4.9. Sort**

Use the **Sort** workflow control to define the order of the files in a file set. You do this because the order is important in the next workflow step.

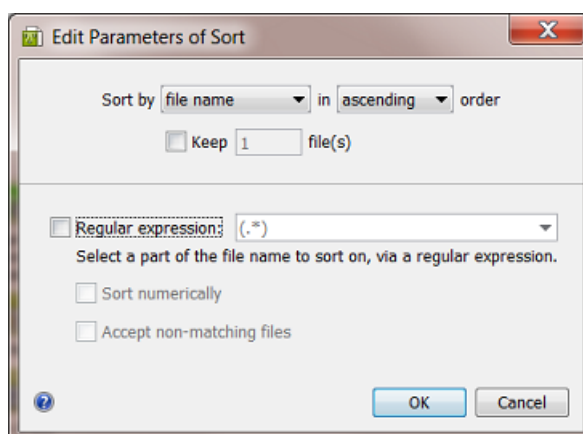

You can sort the files by:

- **file name.**
- **workflow inputs.** Files that entered the workflow first will be at the top of the list.

- **modification date.** This helps you to select the oldest or newest data.
- **SmartName.** The value of a SmartName is calculated per file and that value determines the order.

For every of these methods, you can sort in **ascending** or **descending** order.

**Keep ... file(s):** Use this if you only want to send a specific number of sorted files to the next workflow step.

### Sort by file name

Use a [Regular Expression](#) to define the part of the file name that you want to sort on. The dropdown list shows two example regular expressions:

- (.\*) matches the entire file name
- .\*?([0-9]+) matches the number in the file name (for example to sort files named `cover1.pdf`, `page_2.pdf`, etc.).

Learn more about regular expressions in [Using Regular Expressions](#) on page 702.

- **Sort numerically**

Select this option if you are using a regular expression to extract a number from file names. The results will then be sorted numerically and not as text. For example, a value of 10 will be sorted after 9 when this option is selected. When you don't sort numerically, the values are considered as text: then 10 will come before 9 (as text, the first character 1 comes before 9).

- **Accept non-matching files**

Select this option if you also want to sort files that don't match the criteria. For example your regular expression is based on numbers but the name of one file name doesn't contain numbers.

Any non-matching file(s) will be put at the top of the sorted list.

If you don't use this option and a file does not match, all your files will go to the error output pin.

### Sort by workflow inputs

Files that entered the workflow first will be at the top of the list. You can sort in **ascending** or **descending** order and optionally define how many files you want to keep.

### Sort by modification date

This method can be used to select the oldest or most recent data. See this example where we used the settings **descending** and **Keep 1 file** to sort and end up with only the most recent file:

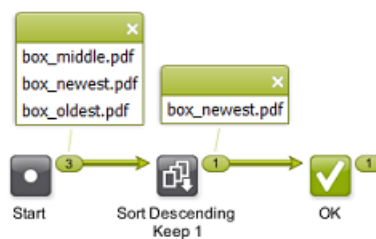

### Sort by SmartName

Select the SmartName you want to sort on. This list only offers custom SmartNames.



Numerical versus text based sorting works as described above for **Sort by file name**. The same is true for the handling of non matching files.

**Example: Sorting by Page Number**

In this workflow, the **Data Collector** collects the pages of a page list after Normalizing, and sends them to the **Sort** workflow control. Learn more about **Data Collector** [here](#).

The **Sort** workflow control then sorts them in the right order, before sending them to the **Create Imposition** task. The files are sorted on **file name**, in **ascending order**, using a **Regular expression** to extract the number in the file name (and with the **Sort numerically** option):

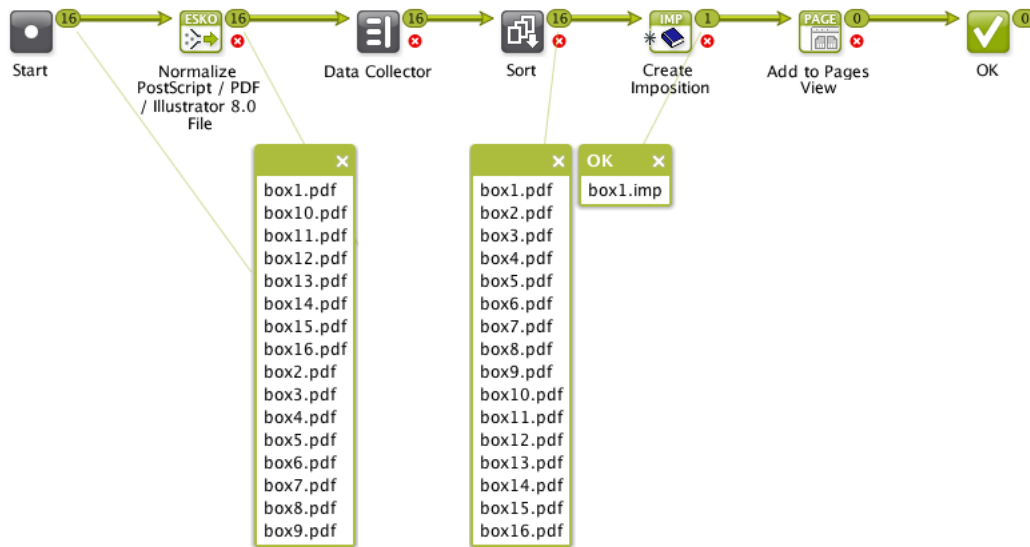

**Example: Sorting by SmartName, Numerically and As Text**

In this example, you want to sort your files by the number that they contain. The number is always mentioned after an underscore. You created a SmartName that extracts, from a file name, everything after the underscore.

This is the result when you **Sort numerically**:

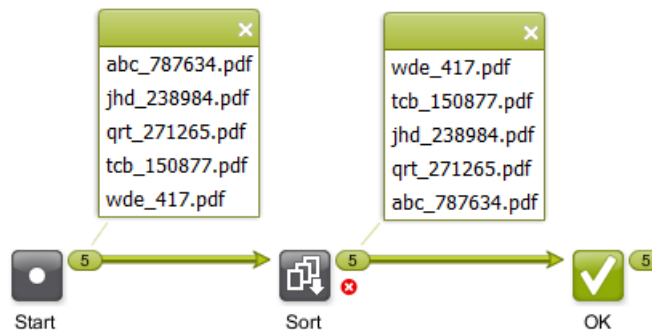

This is the result when you don't **Sort numerically** ; the part of the name after the underscore is now considered as text:

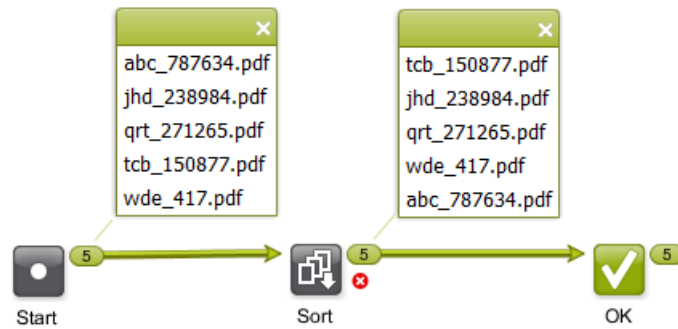

### 10.4.10. Mark File and Select Marked File

These 2 workflow controls are used as a pair. First you use **Mark File** to tag files, then you use **Select Marked File** to select those files later in your workflow.

You can have several pairs of **Mark File** and **Select Marked File** in your workflow, as long as each pair has its own tag.

#### Mark File Settings

In **Mark all incoming items with tag**, enter the tag to set on all files passing through this workflow control.

#### Select Marked File Settings

In **Select all items with tag**, use the drop-down list to select a tag that you entered earlier in the corresponding **Mark File** workflow control.

You can filter the selection of tagged files. Select **Only select when name matches** and enter what name the file should match. You can use SmartName(s), [Regular Expressions](#) or an asterisk \* as a wild card.

If you are working with subworkflows, you can choose to **Also search workflows containing this workflow** (to search 'up'). Learn more about subworkflows [here](#).



**Note:** When no files are found, an empty token will be put on the 'warning' output pin. This allows to continue a next step originating from that warning status.



Learn more about tokens in [Understanding Tokens](#).

#### Example

A typical example is launching tasks on the one-up PDF after your workflow was already working on the Step & Repeat version. In this case, you can tag the one-up file with **Mark File**, later select it with **Select Marked File** and then for example archive it:



**Note:** You need to use the exact same tag in the **Mark File** and the **Select Marked File** step. It is case-sensitive, so we advise to always use the drop-down list.

### 10.4.11. Data Collector

Use the **Data Collector** workflow control

- to collect incoming files from different routes in the workflow and then offer them to the next step as a group
- to wait for files till all expected ones have arrived, and then send them to the next step (without grouping them).

For a Data Collector to know when it has collected all necessary data can be an intensive process when workflows are rather complex, not just in amount of workflow steps and routes, but especially when many files and workflow parameters are involved.



**Note:** This workflow control is actually a 'Token Collector'. It collects tokens in a workflow. We strongly advise to first learn about tokens and file grouping in [Understanding Tokens \(Grouping of Output Files\)](#) on page 796.



**Warning:** Do not make a workflow where you connect the output pin of a Data Collector with the input pin of another Data Collector. The behavior of such a loop is unspecified and so not supported.

#### Example

In this example, the Data Collector waits for all of the files to arrive (one-ups and their reports), then groups them and sends them as one token to the **Zip** task.

The result is one ZIP file containing all the one-ups and also their reports.

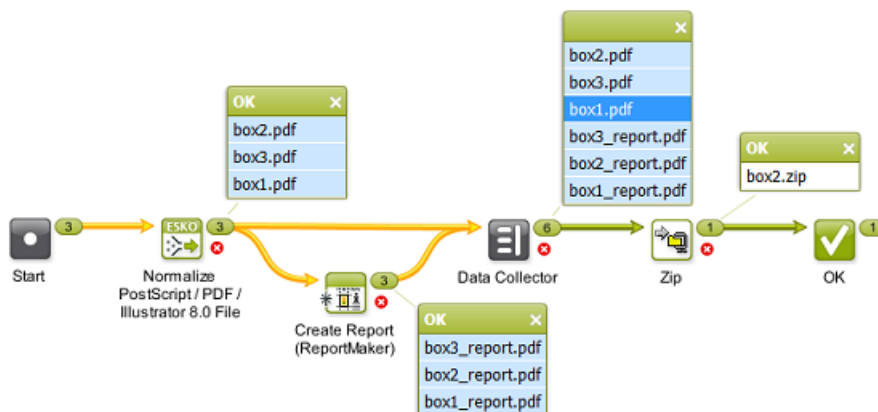

## Settings

- **Error Policy**

Define what needs to happen when errors appeared earlier in the workflow, before this Data Collector step:

- **Fail when errors occur.** When a token arrives that came from a step with an error state, it will end up on the Error output pin. When the token did not come from an error state in this workflow, it will end up on the OK output pin.
- **Ignore errors** (and continue): All output token(s) always end up on the output pin OK.

- **Grouping**

- **Group all collected data:**

- When **selected**, all incoming data are collected into one group. The output pin will show that group as one token.

In the above example, see how, in the output widget of the Data Collector, a mouse-click on `box1.pdf` also highlights all the other members of the group in light-blue (and as usual also highlights the related files in previous workflow steps).

- **Deselect** this option when you want to use a Data Collector as a wait point in your workflow. It then serves to hold the workflow until all previous steps are finished. Once all expected tokens have arrived, the Data Collector allows the workflow to continue, using the same input items (tokens) as they entered the Data Collector (whether they were separate items or already grouped).

In this case, each incoming token will also appear as a separate token on the output pin.

- **Merge workflow parameters from all collected data:**

This option is deselected by default (and disabled when you did not select **Group all collected data**). Any incoming *workflow parameters* then remain attached to their specific file set.

- Deselect this option to keep any workflow parameter values only valid for their specific token. See the below page to see *some examples*.



**Important:** Having this option deselected can have a positive effect on the performance of the workflow. So if your workflow ticket does not require this merging of workflow parameters, we advise to deselect this option.

- Select this option to also merge workflow parameters from the incoming tokens (default setting). The 1 output token will hold 1 set of values for its defined workflow parameters.



**Warning:** Merging workflow parameters can create unwanted effects in your workflow!

Some steps in a workflow can set or change the value of workflow parameters. The token then continues with that new value.

It is not only the dedicated task [Modify Workflow Parameters Values](#) that can set these values, also the tasks [Checkpoint - To Do](#) and [Integrate with WebCenter](#) can do that.

When that token then arrives at the Data Collector, the values that its workflow parameters then have will be those in its output token(s).

However, when these tokens arrive from different routes, how should the workflow engine decide of which token it should choose that parameter and its value?

See the below page to learn more on this complex matter. It uses [some examples](#) to illustrate why the result of this 'merge' option is unpredictable.



**Note:**

- Before AE 20, this was not even an option in the Data Collector and merging the workflow parameters was even the default built-in behavior.
- From AE 20 on, it became an option and it was selected by default (to respect the previous hidden behavior). On this page in the manual, we then also started to document its possible problems and to advise to deselect it anyway.
- From AE 23.11 on, the default behavior changed to being deselected. This state is technically harmless and, most important, it so prevents that new workflows are using this option unintentionally / without reason.

## Examples of the Challenges in Merging Workflow Parameters

### The Problem with Merging Workflow Parameters

The Data Collector is typically used to collect data from several routes. And back-tracking information in very complex workflow is a very intensive action for a workflow. Of course it's a lot easier when a workflow is only 1 linear route: a same file can only be collected once and its workflow parameter's last set value is the only one arriving in the Data Collector.

In the Data Collector, the option to **Merge workflow parameters from all collected data** raises these 2 challenges:

- **Unpredictable result:**

Except in very simple workflows, it is not clear which parameter values will be part of the grouped token that the Data Collector outputs.

When different workflow routes end up in the Data Collector, and when, for a same workflow parameter, each route sets a different value, which value should then be taken? And also, does it still matter at that point in the workflow? Maybe the values were already 'used' by earlier workflow steps...

The workflow engine tends to keep the first value that arrived at the Data Collector but the problem is that timing *within* a workflow can not be controlled. You can not predict the moment of execution of specific steps within a workflow. The time that a workflow step starts is always influenced by the load of the workflow engine at that specific time, by available memory of the server computer, etc.

When asked to find a value or choose between values for a same parameter, the workflow engine tends to pick the first value arriving, but because we can not control the time they arrive, we can not be 100% sure which one that will be.

**Conclusion:** When, in different routes, different values were set for a same parameter, the resulting parameter value is **unpredictable**.

- **Load on the workflow engine:**

The back-tracking that the Data Collector needs to do to find all relevant data, can, in specific and complex workflows, lead to an extreme **load on the workflow engine**.

A Data Collector collects, i.e. it searches back in the workflow routes for the tokens it should collect. But it also collects the tokens' parameters and the value of those parameters that it should hand over to the next step in the workflow, as part of its grouped output token. When you have a large workflow, with several routes, where parameters were modified, where you may have added more than one data collector, this becomes a massive investigation to be done back in the workflow.

See some examples and resulting advice below. The examples are minimal, i.e. they only show what is relevant for this explanation.

### Setup of our Example Workflow

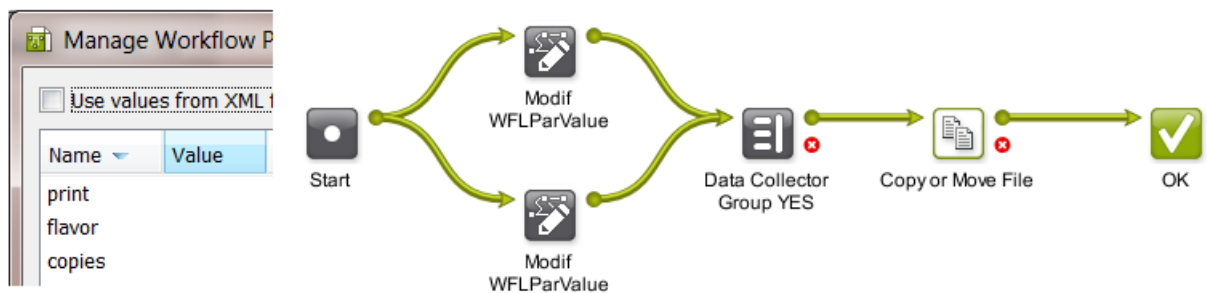

1. Our example workflow has 3 workflow parameters: `print`, `flavor` and `copies`. In our case, their initial value is empty.
2. Each input file is sent to 2 routes. In each route, the value of one or more workflow parameters is modified.

**Note:** We here use the step *Modify workflow parameter values*, but, as mentioned above, there are more task types that can set values of workflow parameters.

3. The Data Collector groups the files coming out of these routes. This is where the below examples show the different cases: What happened to the workflow parameters in these routes? Should the Data Collector look them all up and merge them for the output token? Are they really all still relevant to the next steps in the workflow? And what if a token received different values for a same parameter?
4. We use the Copy or Move File task as a little trick to quickly see the resulting parameter values. We have it create a file which name contains the value of the workflow parameters.





**Restriction:** Unfortunately, in the workflow editor, you can not use the tool **Workflow Parameter Values** to help analyse what is happening in below examples. This tool uses another algorithm that does not show the result of this option to merge parameters.

**Example 1a - Non-overlapping Parameters - Merge NO**

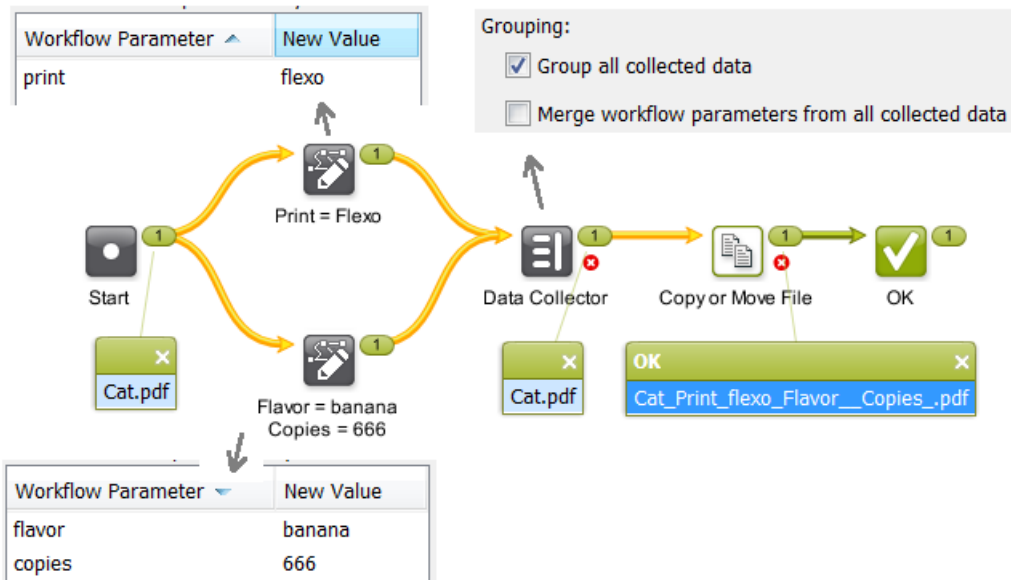

- For sake of simplicity, the workflow was started with 1 input file. The result would be the same with multiple input files (and then at least the Data Collector would indeed 'group' at least these 2).
- After splitting into routes, the top workflow control sets the value for the workflow parameter `print` to `flexo`. The bottom one sets a value for the 2 other parameters, `flavor` and `copies`. The parameters do not overlap once they arrive at the Data Collector.
- The Data Collector groups and is not asked to merge the incoming workflow parameters, which in this case would be easy as they do not overlap. So which ones will he keep then, in the group output token, those that came from the top route or those from the bottom route?
- The name of the output file shows us that the workflow did 'receive' the value `flexo` for the parameter `print` from the top route, but that it's not aware of the changes done to other 2 workflow parameters in the bottom route. It didn't even check them after it already received a value from, in this case, the top route.
- The result actually could have been be the reverse as well: that the parameters from the bottom route were used, and not those from the top one.
- **Conclusion:** A simple re-run of this workflow could have a different result. Any other activity in the workflow engine could slow down any workflow step or route and so change the sequence in which they arrive at the Data Collector. The result is unpredictable.

**Example 1b - Non-overlapping Parameters - Merge YES**

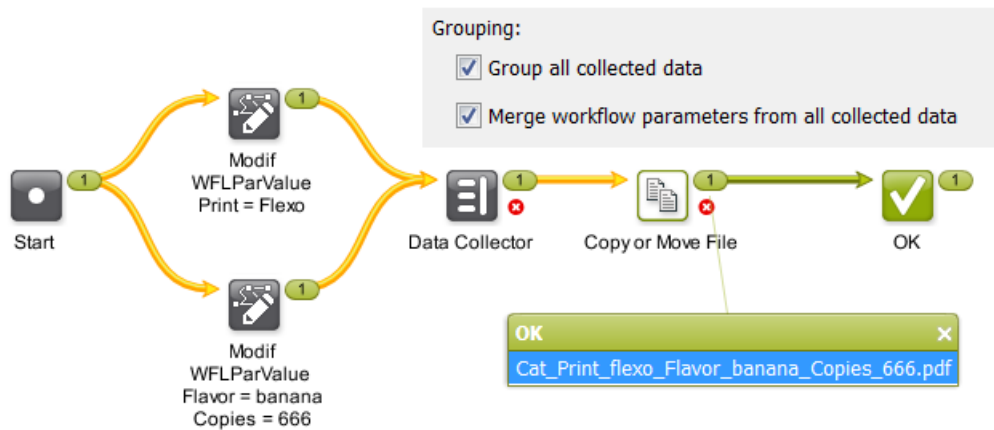

- Same workflow, same input file(s). The only difference is that we ask the Data Collector to also merge the workflow parameters.
- At the end of the workflow, the name of the output file now shows that all 3 workflow parameters were successfully merged into the output token.
- **Conclusion:** This may look good but we were lucky: It is not always realistic to keep the parameters unique over their route, and, most important, this workflow was very simple. A real workflow would have become noticeably slower.

**Example 2a - Overlapping Parameter Values - Merge NO**

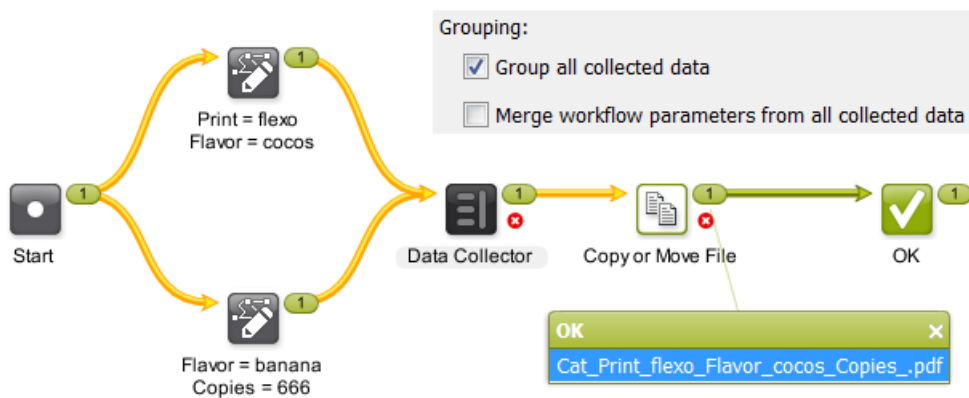

- In this case, both routes set a value for the parameter `flavor`.
- The Data Collector is not asked to merge parameters. It can take either one of the values. It picks one route to check back on and as soon as it finds a value, that one will be taken.
- This time, we see that the value `cocos` was chosen to be forwarded with the output token.
- Relaunching this workflow in realistic circumstances can as well result in the value `banana`.
- **Conclusion:** It can not be predicted which value will be taken.

**Example 2b - Overlapping Parameter Values - Merge YES**



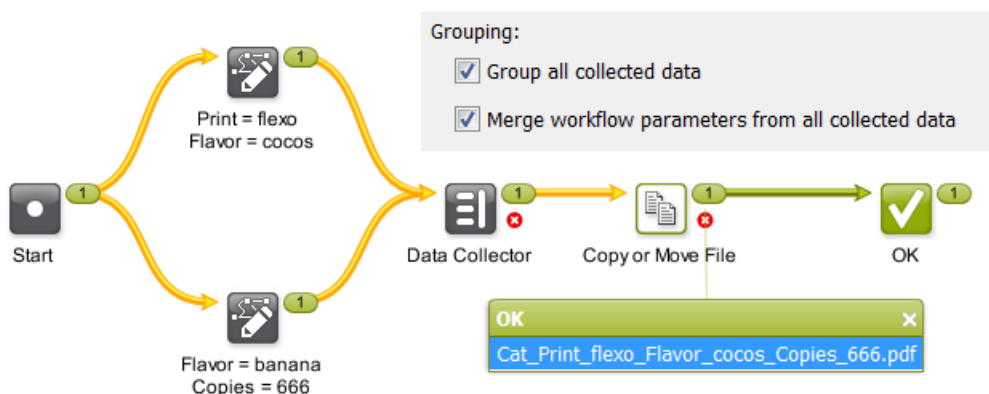

- Also in this case, both routes set a value for the parameter `flavor`.
- Now, the Data Collector is asked to merge parameters. It therefore will check back in the workflow and assemble all the values for all workflow parameters.
- Both routes were investigated and all parameters from both routes were merged.
- In the result, notice how now the parameter `copies` got a value as well (from the bottom route). And that the values for the other 2 parameters came from the top route.
- Relaunching this workflow on a busy server can have a different result.
- **Conclusion:** A request to merge means that the Data Collector needs to do a lot more investigation but still it can not be predicted which value will be taken.

### Resulting Advice

**The process of merging workflow parameters can be problematic to the workflow engine and its result can not even be predicted.**

Therefore,

- we advise to build your workflows in a way that you do NOT need to ask to merge workflow parameters. As mentioned, this also benefits the processing of the workflow engine in general.
- we advise that, if in some simple workflow you do need this option, that you thoroughly test it. Be aware that the results are unpredictable and that it increases the processing load of the workflow engine.

## 10.4.12. Data Splitter

Use the **Data Splitter** if you want the next step in the workflow to process each file individually. It can also be used to group files according to customised criteria.



**Attention:** Only use this task when necessary ; when the default behavior of the workflow is not what you want. This kind of splitting can create a very large amount of extra 'tokens' and that significantly increases the complexity and load of the workflow engine. Learn more in [Avoid excessive amounts of Tokens](#) on page 777.



**Important:** We advise to first learn about how a workflow can process files in groups in the page [Understanding Tokens \(Grouping of Output Files\)](#) on page 796.

**Example**

In this example, the Data Splitter (with the default setting **One by one**) sends the unzipped files to the **Checkpoint** task one by one. This way, **5 To-Do Actions** are created. The user needs to decide for each file if it needs manual or background trapping:

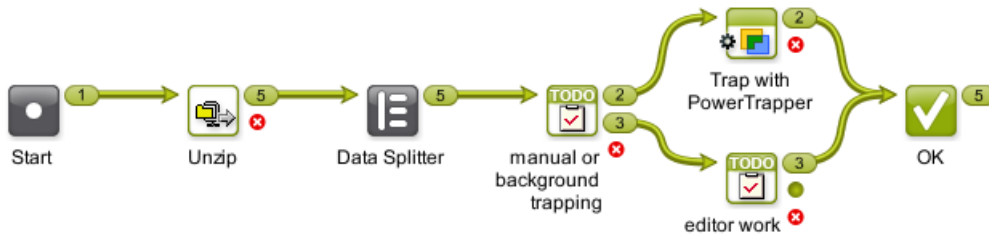

Without the Data Splitter in this workflow, there would only be one **To-Do Action**. The Action item would provide a link to the 5 files, but they would need to share the same decision.



**Important:** When splitting the incoming files as 'One by one', beware when the next step is a task that is launched on one file at the time: An excessive amounts of sub-tasks will lead to creating an excessive amount of tokens which can be problematic for your workflow server. Learn more in [Avoid excessive amounts of Tokens](#) on page 777.

**Split and Create a (new) Group**

You can also use the Data Splitter to split the collected files and **group** them according to a criterion you define. This will also group the tokens into one same token.

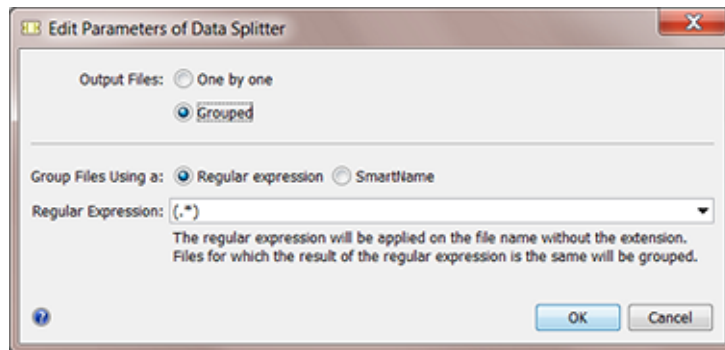

You can group the output by using a [Regular Expression](#) or a **SmartName**.

The dropdown list by default offers 2 regular expressions:

- (.\*) matches the entire file name without the extension
- .\*\_pag([0-9]+).\*? matches the number directly after \_pag in the file name (use this for example for files named page\_1.pdf, pagina\_2.pdf, etc.).

Only the file name will be matched, without the extension. Learn more about regular expressions in [Using Regular Expressions](#) on page 702.

**Example: Grouping the RIP output to Prepare for Viewing**

The Automation Engine **Viewer** enables viewing of RIP'ed data when they were **prepared for viewing** together, as a group. When you have a folder containing RIP output of several jobs, it is important that you send the right groups of separations to the **Prepare for Viewing** task. You can use the Data Splitter and group the separations by using a SmartName:

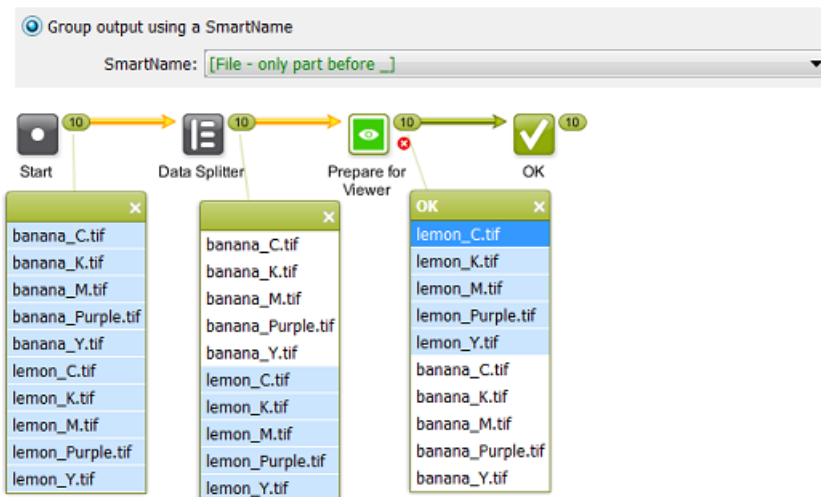

**Note:** You can use the same principle in a workflow where you use the **Create Wrapper file** task.

### 10.4.13. Fork and Join



**Note:** We advise to first learn about file grouping in [Understanding Tokens \(Grouping of Output Files\)](#) on page 796.

- The **Fork** workflow control automatically tags every input file with a same token as all the files that the workflow generates from those initial files in the next steps, this until you **Join** them again. This creates a **Group Tag**: These related files all get a same **token**.



**Restriction:** You can only use a maximum of 5 Join steps in a workflow. This was intentionally built in to protect the workflow engine. When reaching the 5th Join step the workflow will stop and the log file will mention "Token-Persistency problem occurred".

Because a Join step also serves as protection for the workflow engine, it serves as 'minus 1' when calculating the amount of Fork steps. For example you can have 3 Fork steps, followed by a Join step and then again followed by 3 Fork steps.

- The **Join** workflow control then groups all the files with the same tag.

#### Example of Group Tagging

Our example workflow creates a ZIP containing the one-up PDF and its report PDF. This is easy to set up when the workflow starts with only one file. This is different when your workflow starts with multiple files:

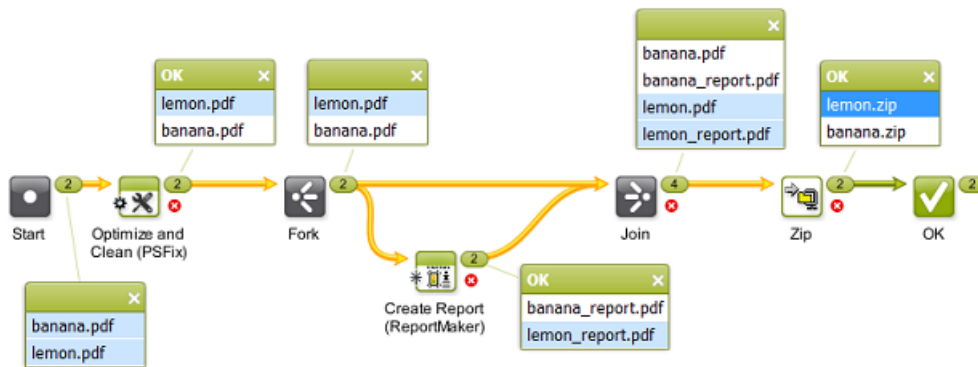

In above example,

- we have 2 input files that will travel through this workflow together. This example starts with an 'Optimize and Clean' step, just as an example of a task that outputs more than one file.
- the **Fork** step then starts tagging each input file and each file created from that file with a same token. In this example this is the input file and its report file that is created in the next step.
- the **Join** step creates 2 groups based on those tokens:
  - one group is the `lemon.pdf` and the `lemon_report.pdf`
  - another group is the `banana.pdf` and the `banana_report.pdf`
- these groups then become the inputs for the **Zip** task. You now have a Zip file per group: 2 Zip files.

**Without** the **Fork and Join** steps, you get 4 ZIP files: one for every file. If you use a **Data Collector** to group all of them, you get 1 ZIP of all 4 files.

**With** these **Fork and Join** steps, you can get the ZIP files of the 2 'related / grouped' files.



**Note:** This **Fork and Join** combination so enables special cases that you can not solve by using the more general [Data Collector](#) or [Data Splitter](#).

## 10.5. Using Public Parameters in Workflows



**Note:** Public Parameters are not only available for workflows tickets but also for single task tickets. This is documented in [Using Public Parameters in Automation Engine](#) on page 99. We here only add the specifics about using public parameters in workflow tickets.

### 10.5.1. Concept

Most Task Tickets offer many settings ('parameters'). And Workflows can be quite complex combinations of many such Tickets. That is why, when an administrator creates a workflow, it can be useful to not show this whole complexity to every day users of those workflows.

This can be done by making only some parameters public. Thus, the daily user can only see and modify a limited set of parameters that he understands and is allowed to change.

For example:

A user wants to launch a workflow and needs to check or change only a few settings. Instead of having him open the workflow and open several steps to change only 5 parameters, you offer him this simple dialog, where he is asked to define the 5 parameters that you made public to him:

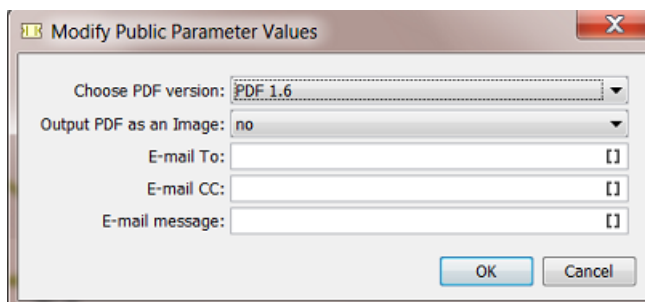

When the user presses **OK**, the workflow starts and uses the chosen settings.

### Available from many Client Applications

This functionality is available for users launching workflows from these applications that have a connection with the Automation Engine server:

- Automation Engine clients Pilot, Shuttle and from the browser client workspaces
- Esko editors ArtPro+ and DeskPack (Adobe Illustrator)
- Esko legacy editors ArtPro, PackEdge, Plato, FastImpose.



#### Important:

- Client applications only show **Public** tickets and workflows, no matter what user is logged in. In other words, they only show the same list of tickets that a user sees who does *not* have the User Access Right "**Tickets: Show all Tickets and their Parameters (Public and other)**".
- If those public tickets and workflows do not have any public parameters, the user will not be able to open them to change any parameters. They will be launched right after he selected the (workflow) ticket.

### Preference to have the Pilot show Only Public Parameters

In the Pilot, in **Edit > Preferences** the option **Show only Public Parameters in Tickets** can help you prevent users from opening workflows in the workflow editor and so having access to all settings.

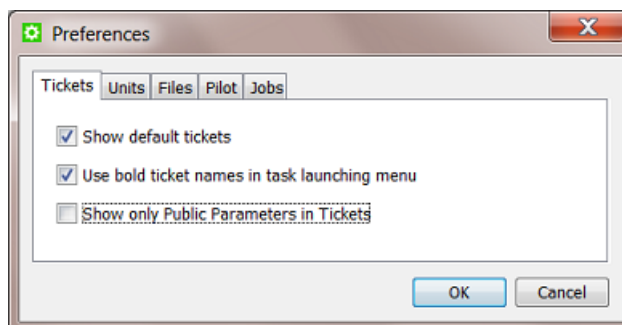

- When this option is not checked, users will be able to open workflow tickets and see all steps and settings. If they can make changes and save the ticket depends on their **User Access Rights**.
- When this option is checked, a users that opens a workflow ticket will only be shown a dialog with the public parameters of that workflow. When that workflow has no public parameters, the user will see this dialog:

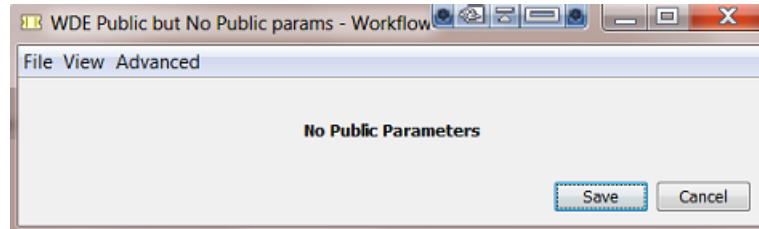

### About Public Parameters in a Workflow Ticket that is Not Public

It is possible to set public parameters in a workflow ticket that is not saved as public. This can be useful when the non public workflow ticket is referenced inside a master workflow that is public. The public parameters of the referenced subworkflow will show up in the list of public parameters of the master workflow.

## 10.5.2. Creating Public Parameters in a Workflow

Creating public parameters in a workflow is very similar to creating them for a single task ticket, as explained in [Making a Parameter Public](#) on page 99.

A summary:

1. In the workflow editor, select a step and open the ticket.
2. Right-click the parameter you want to make public and choose **Make Parameter Public**.

We here right-clicked in the field for **Trapping Distance**:

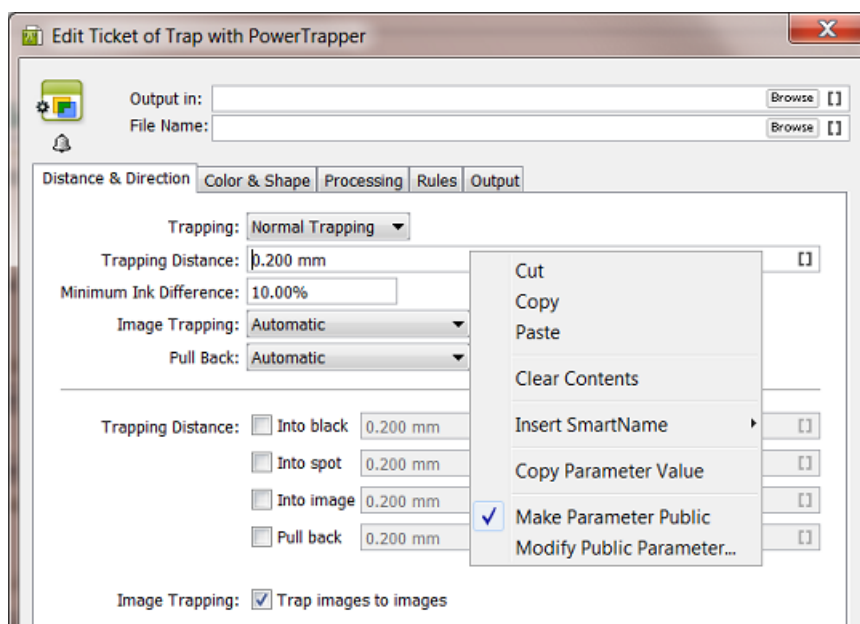

**Note:** Not all parameters of all tickets can be made public.

3. Right-click the same parameter again and choose **Modify Public Parameter....** Decide here if you want the parameter to be a free or predefined value.



**Note:** You can also skip this step and later manage this and all other public parameters in the [Manage Public Parameters](#) dialog. You can also use both dialogs.

4. Save your ticket to also save these changes to your public parameters.



**Note:** Public parameters belonging to steps that you later deleted from the workflow are not removed. You can remove them using the **Manage Public Parameters** dialog.

Next step is to manage the workflow parameters in a special dialog where you will define more precisely how they will present themselves to the user.

### 10.5.3. Conditional Availability of Public Parameters

#### Concept

Some parameters depend on others. An extra tool offers to disable or even hide parameters depending on the state of others.

Below examples illustrate the functionality.

At the end of this page, we mention some limitations.

#### Example 1: Conditional Availability of one Parameter

This example shows the basic principle: When the parameter 'Add Overlaps' is not enabled, the parameter 'Overlap Distance' becomes irrelevant. However, the user still sees this option and can even fill it in.

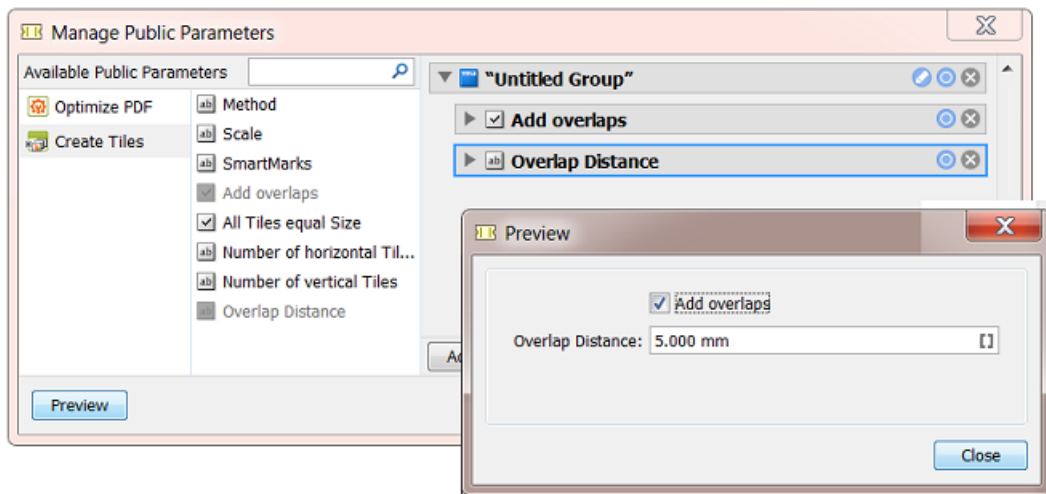

We will use the blue circle button  to make this dialog more user friendly.

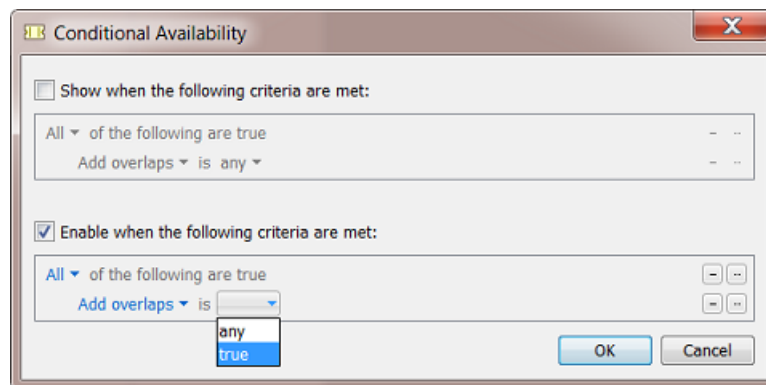

- Click the  of the parameter 'Overlap Distance'.
- The dialog **Conditional Availability** allows to **Show** / hide this parameter, or to just **Enable** / disable it.
- To only disable it, deselect the option **Show when the following criteria are met**, select the **Enable** option and set the criteria when this parameter should be enabled. In our example, this is when the user selected the parameter 'Add overlaps'.



- In the list of criteria, the dialog automatically already lists the other parameters in that group of public parameters that can be used as a condition.



**Note:** Not all types of public parameters can be used to build a condition on. Learn more at the end of this page.



- Click **OK**. Notice how the blue circle button  now changed to , indicating that a condition has been set for this parameter.

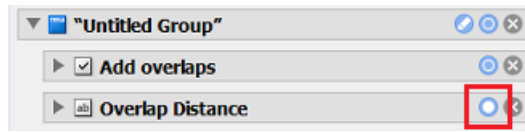

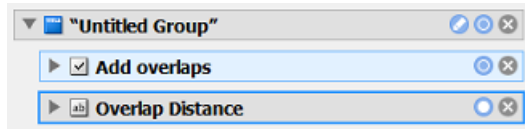

Also, when you select that parameter, the other parameter(s) that were used as criteria for the condition will be highlighted in light blue:



**Note:** When you remove a parameter that was used to set a condition, then those conditions will also be removed from those parameters: the blue circle button of the inflicted parameters will change back from  to .

- Now click **Preview**. See how when no overlaps are asked for, the distance parameter is disabled (greyed out):

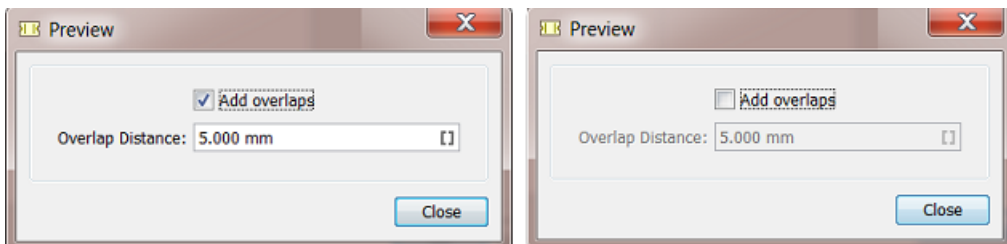

- If you prefer to not just disable an option that became redundant, but even hide it, then set one or more criteria for the **Show** option:

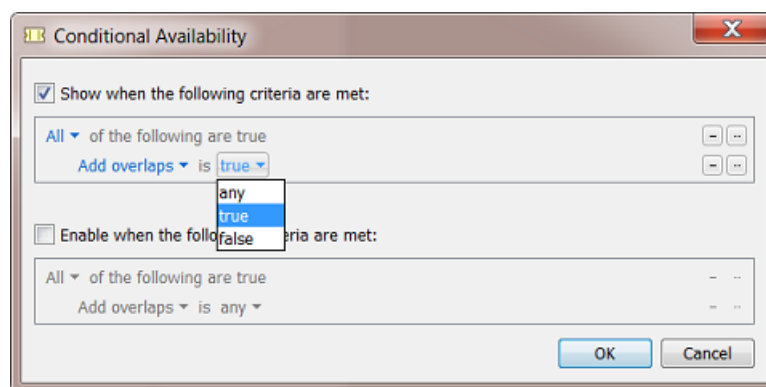

The preview will then show you this:

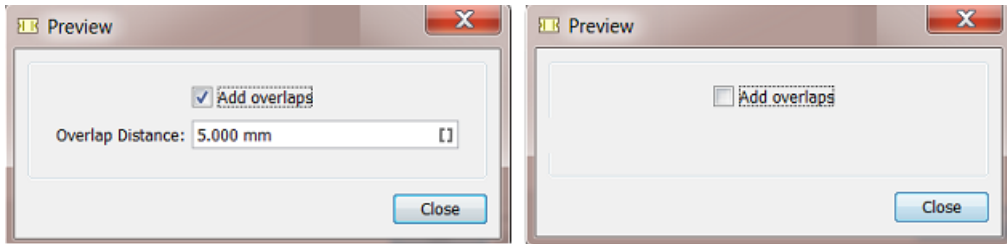

**Example 2: Conditional Availability of Multiple Parameters**

- You can also set a same condition for multiple parameters.
- Select multiple parameters, right-click any of them and choose **Conditional Availability**.

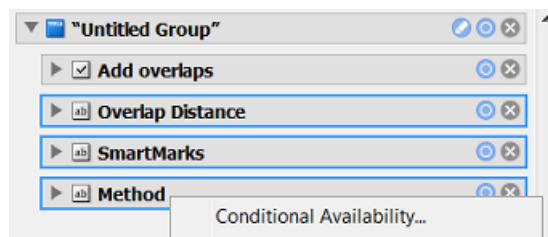

- The dialog shows message you that what you now apply will be valid for all the selected parameters.

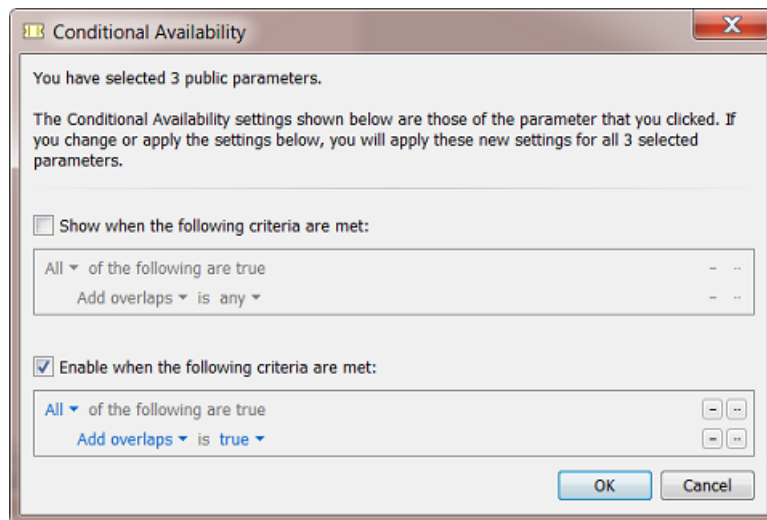

- Similar to the settings we showed above, using the **Show** or the **Enable** option, you can now get these example results:

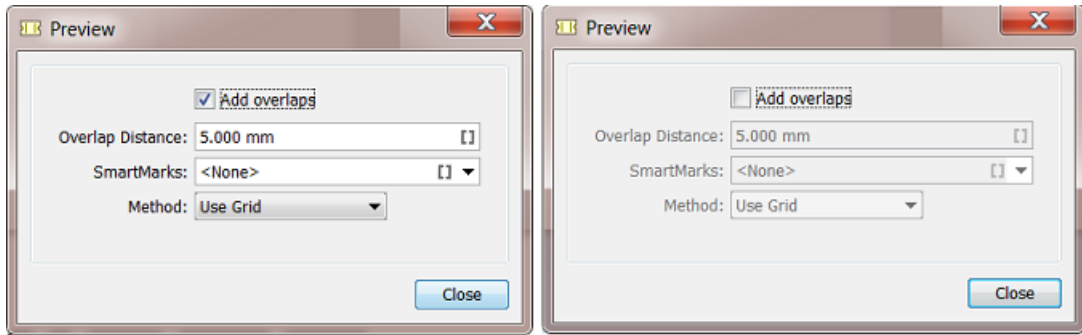

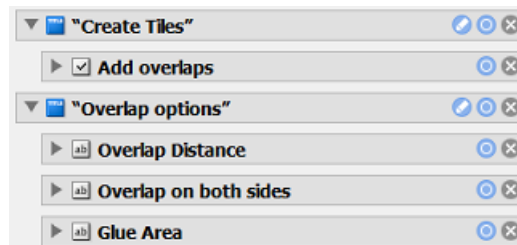

**Example 3: Conditional Availability of a Group of Parameters**

- This time we organized 4 parameters in 2 groups and gave these groups a good name:

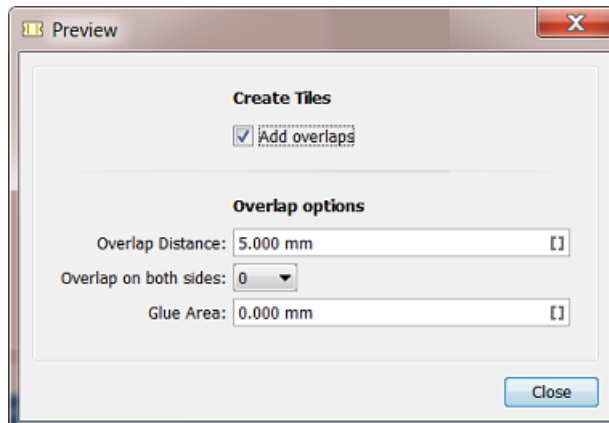

- This results in this preview:



- Because the overlap options only make sense when overlaps are requested, we can now set this condition on group level, instead of setting the same condition for each of those option parameters. We now click the  of the group 'Overlap options'.
- We choose to only show that group when 'Add overlaps' is selected:

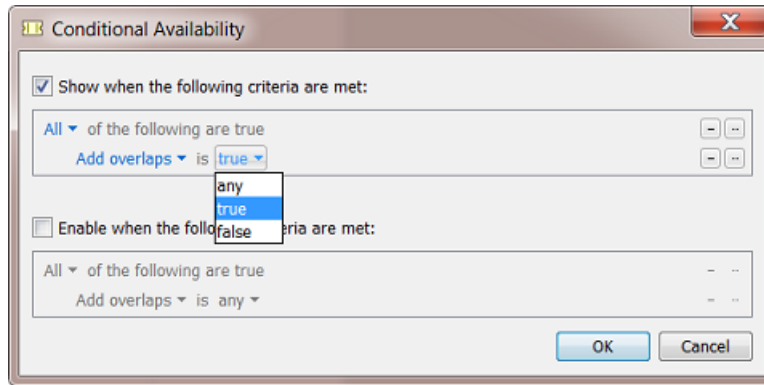

- See the result in both cases:

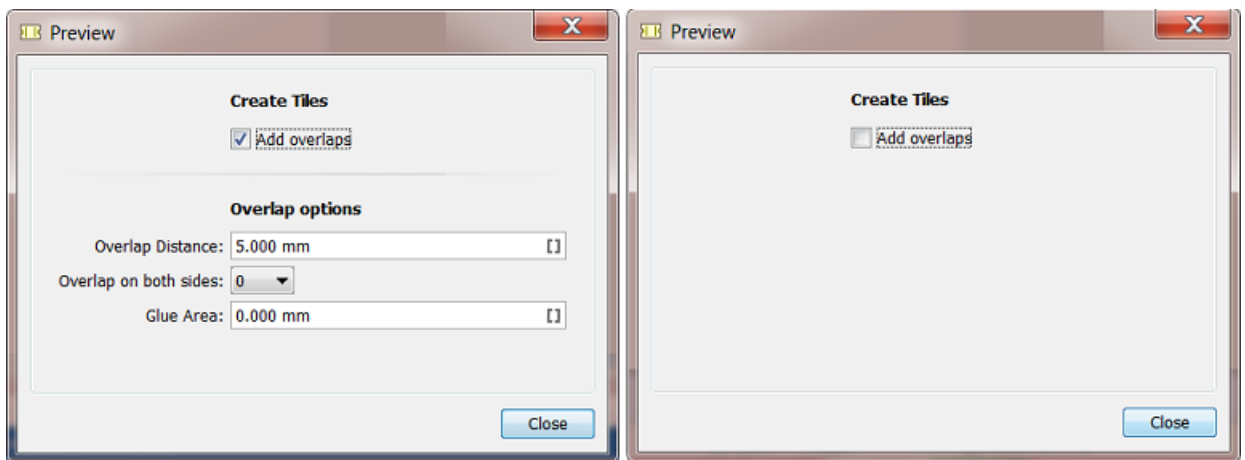

### Example 4: Combination

- Building on the above example, we add an extra condition within that group:

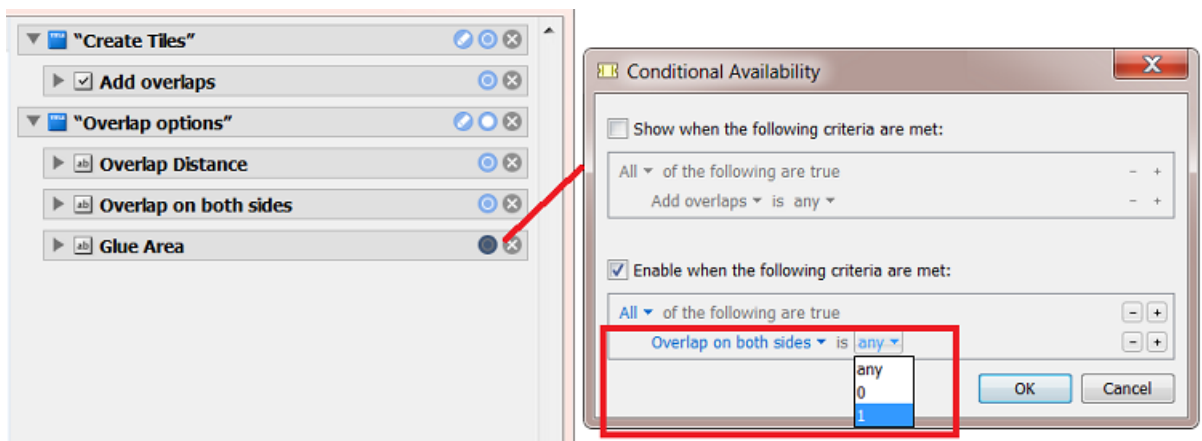

- When the group 'Overlap options' is shown, now see the result with either value of the parameter 'Overlap on both sides':

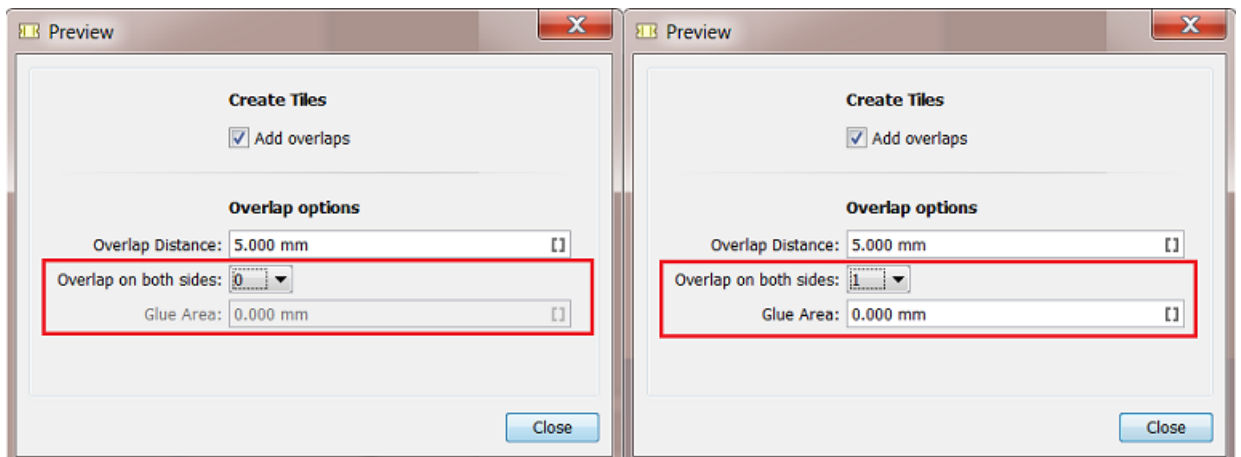

### Limitations

These are parameters that require a fixed value, for example yes-no, top-right-bottom-left, etc.) or whose value is another kind of clear unmistakable value, for example (a part of) a text or number, etc.

Some parameters however result in values that cannot be used to base a condition on, for example a numeric field where the value is also defined by its unit or a table, or for example a table of names of layers to be removed. Such parameters cannot be used in a condition ; they will automatically not present them themselves in this dialog.



**Note:** You can use a parameter based on a table when you created predefined settings. for that table. This way, you can base a condition on whether 'Table 1' was selected or 'Table 2', etc.

## 10.5.4. Managing Public Parameters in a Workflow

Once you have made parameters public in your workflow steps, you can open the **Manage Public Parameters** dialog to get an overview and make changes.

1. In the workflow editor, go to **Advanced > Manage Public Parameters...**

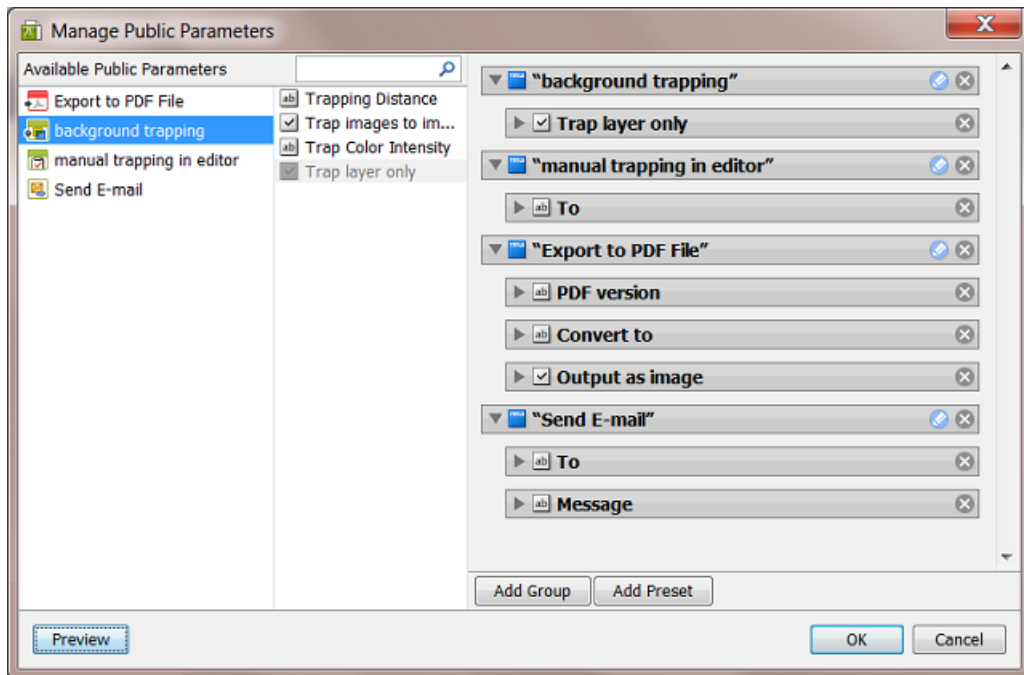

The dialog shows all public parameters of this workflow, sorted by workflow step:



- **The left pane** shows the workflow steps for which you have made parameters public.
- **The middle pane** shows the public parameters of the workflow step that was selected on the left. They are greyed out when they are already used in the right pane. When parameters are not used in the right pane, they will not be public parameters.
- **The right pane** shows all the public parameters in detail (name, type of value, etc.). They are default organized in **Groups** matching the (custom) name of the step where they came from. This is where you build the dialog that the users will see and use to decide the values before launching the workflow.
- The **Preview** button shows how the end-user will see the panel you are building here.

To help you trace their origin, selecting items in the panels also shows selections of related items in the other panels.

2. You can

- drag parameters from the middle to the right pane to make them public. For example dragging the parameter **Trapping Distance** into the group **"background trapping"**.
- click on  to remove the parameter or group from the right pane. It will then not be public anymore.
- re-arrange the order of your public parameters or groups (drag them up or down).
- click on  to change the default name of the group.

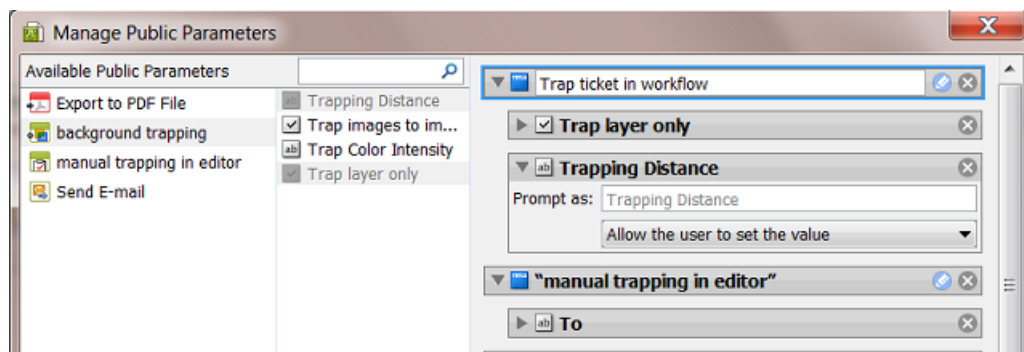

- change the settings of the public parameters. Define in **'Prompt as'** is what the user will see. Instead of **Allowing the user to set a value**, you can offer the user a choice of predefined values.

In below example the user will get a drop-down list to choose between **Flexo normal** and **Flexo large**. The user making this choice when launching the workflow will not see the actual values of 0,2 and 0,3 mm.

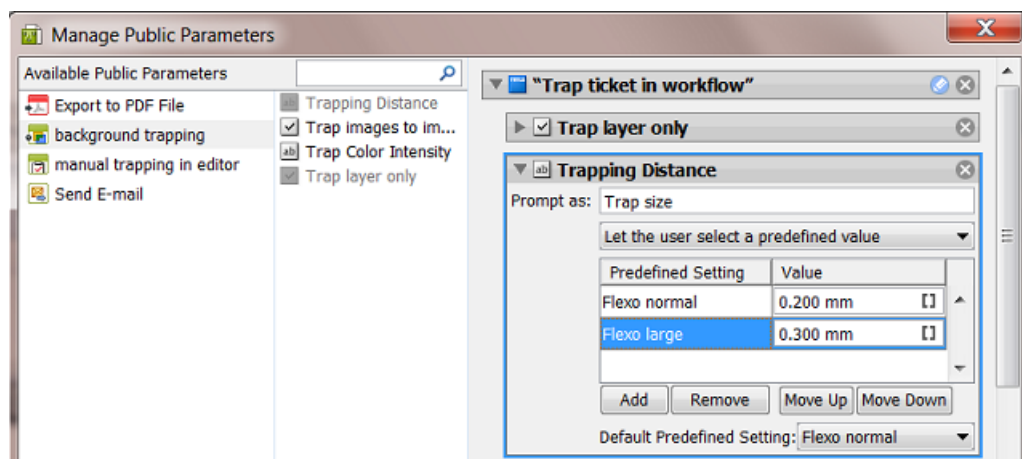

Use the buttons **Move Up / Down** to define the order of the **Predefined Settings** in the drop-down list that the end-user will see.

Learn more about editing and re-designing this pane in [Making Presets to Simplify the Users' Choices](#) on page 102 and [Example of Further Customizing the Public Parameters Dialog](#) on page 852.

### 10.5.5. Making Presets to Simplify the Users' Choices

**Presets** are customized combinations of parameters. They limit the amount of decisions that users have to make.

#### Example

Let's assume you want users to use different trapping settings when printing offset versus dry offset. You can collect those trapping settings in a **Preset**, so that users will only have to choose between 'offset' and 'dry offset'.

We start from a dialog of a workflow ticket where the trapping step has 3 public parameters:

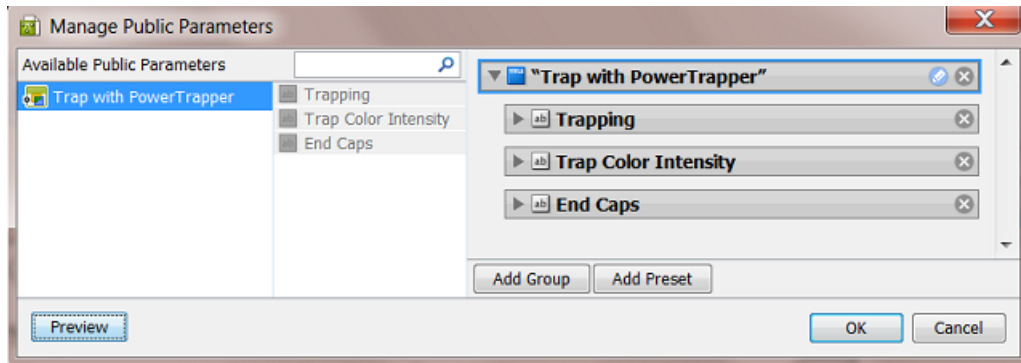

1. Click to remove the (default) **Group** named "Trap with PowerTrapper"

2. Click **Add Group**.

A new "Untitled Group" is created. Click to change its name.

3. Click **Add Preset**.

A new "Preset" is created. Click to change its name.

By default, two example values will appear. The preset was renamed to 'Choosing Process to Decide Traps':

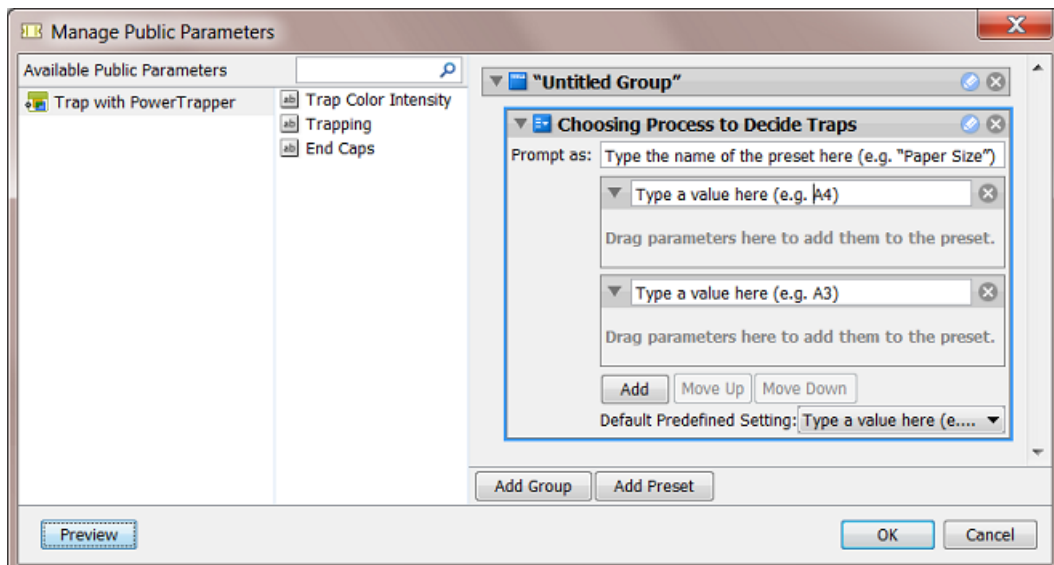

4. Define what the users will see:

- a) in **Prompt as**, enter the text that users will see (replacing 'Type the name of the preset here (e.g. "Paper Size")')
- b) enter the values that the users will choose from (replacing 'Type a value here (e.g. A4)'). In our example, we add 'Offset' and 'Dry Offset'.

Click **Add** if you want to add extra values (not the case in our example).

5. Drag the parameters from the dialog's middle pane onto one preset item. This will make them automatically appear under each preset item (here both under `Offset` and `Dry Offset`).



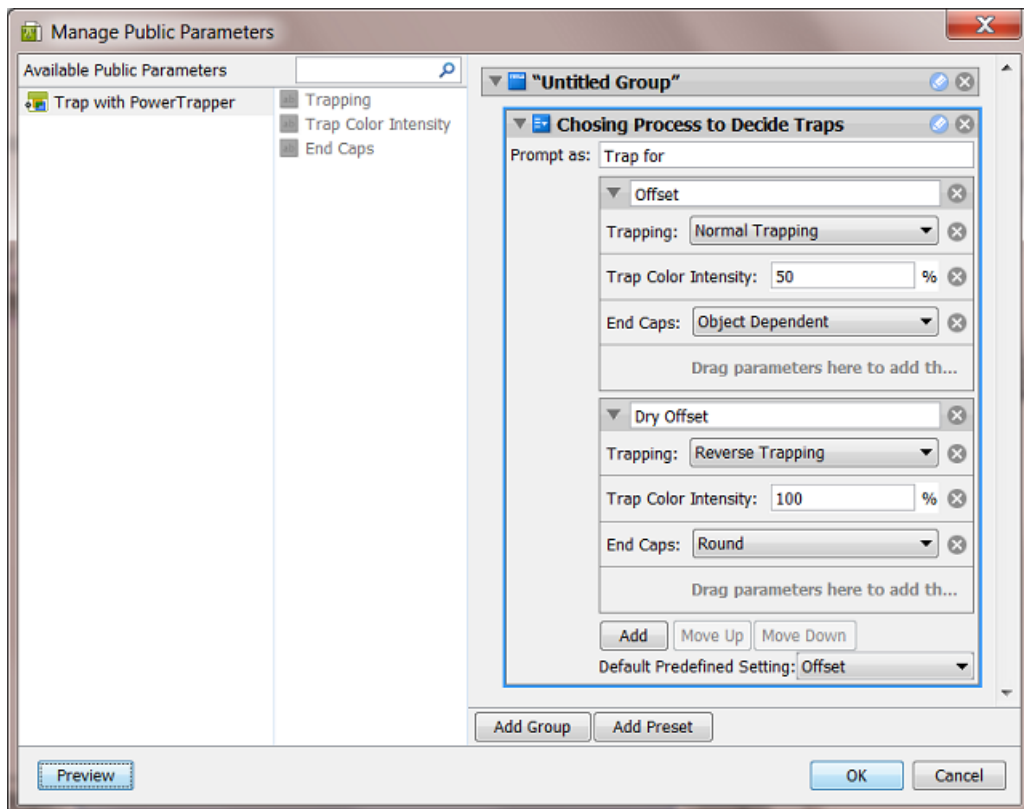
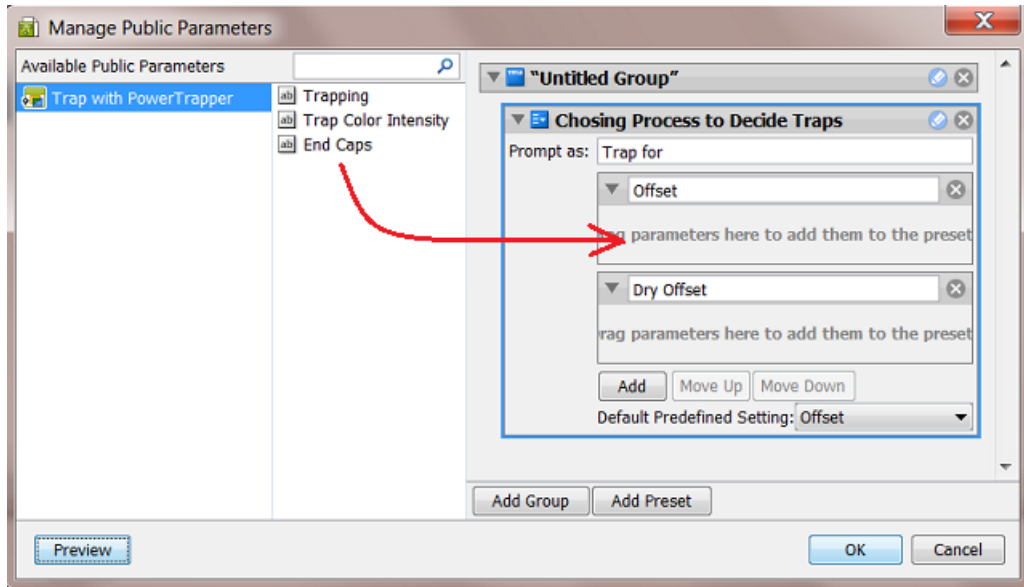

6. Define the parameters values for each preset item.  
See the above screenshot for a good example.
7. Use the buttons **Move Up / Down** to define the order of the **Presets** in the panel that the end-user will see.

8. Click **OK** to confirm and close the dialog.
9. Save your ticket to also save these public parameters.

This is how the resulting dialog will look like to the users of the client applications:



### 10.5.6. Example of Further Customizing the Public Parameters Dialog

In this example, we further customize the public parameters dialog by reorganizing the **Groups** and adding a **Preset** to combine parameters.

#### Step 1 - Example Workflow and its Initial Public Parameters Dialog

This is our example workflow:



We created public parameters in 4 steps. This is the initial **Manage Public Parameters** dialog, where the groups match the workflow steps:

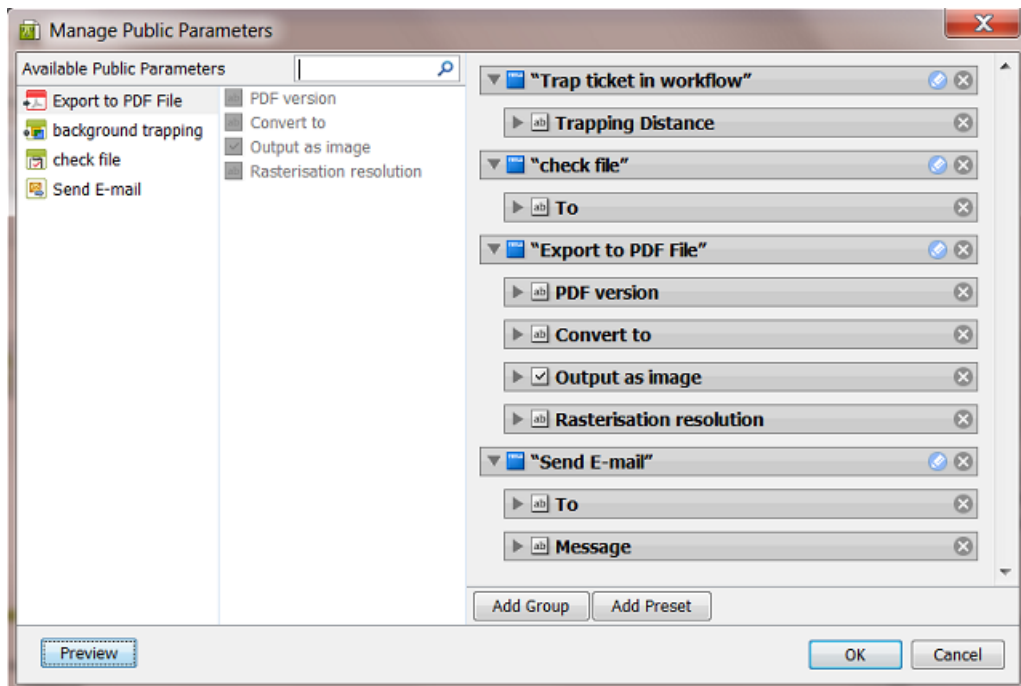

If you don't customize this, the resulting dialog, that will be shown to the users launching a task, will look like this:

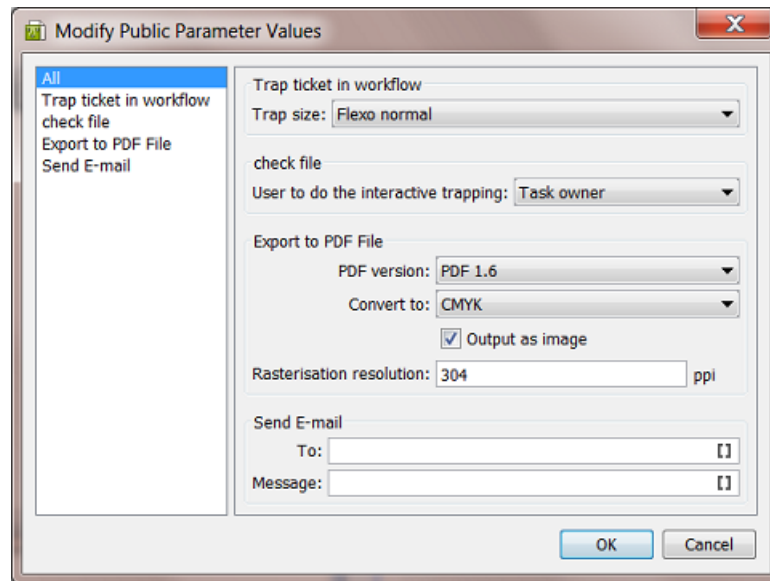

In this dialog, you can see

- that the items on the left pane of this dialog match the groups in the **Manage Public Parameters** dialog.
- that when there are multiple groups, an extra one named 'All' is automatically created. This group offers all parameters together.
- that the parameter 'Trap size' is offered as a choice of presets. This was illustrated [earlier](#).

In the next steps we will further optimize this dialog for the end user.

## Step 2 - Customizing the Groups and the Text that the User will See

- In the group "check file",
  - rename the group to "Who to Check",
  - change **Prompt as** to 'User to Check the File in Editor',
  - set the **Default Predefined Setting** to 'Any User'.

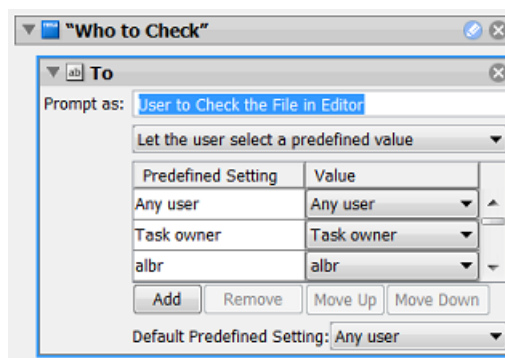

- Press **Add Group** to create a new group and name it "E-mail to Customer".
- In the right pane, drag the parameters from the groups "Export to PDF File" and "Send E-mail" into this new group.



**Tip:** You can press **Shift** to select and drag multiple parameters.

- Remove these two groups that are now empty: "Export to PDF File" and "Send E-mail". This is the result:

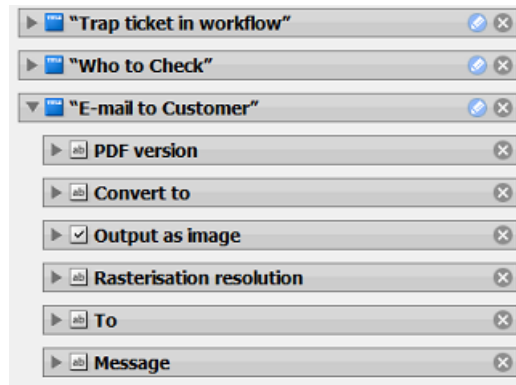

**Note:** An alternative way to do this, is to first delete the 2 groups, then create the new one and then drag the 5 parameters from the middle pane into the new group.

### Step 3 - Adding a Preset and Combining Parameters

In the new **Group** "E-mail to Customer", we now combine 2 parameters into a new **Preset**:

- Press **Add Preset**. A new preset appears at the bottom of the bottom group. Rename it to 'PDF pixel version'.
- Set the **Prompt As** to 'Convert to Image'
- Press **Add** to add a third parameter and rename the 3 parameters to 'No', 'Yes (304 ppi)' and 'Yes (120 ppi)'.  
 Note: The original text says 'Yes (120 ppi)' but the image shows 'Yes (120 dpi)'. I will use the text as written.
- Drag the parameters 'Output as Image' and 'Rasterization Resolution' onto the first value of this new preset.
- Adapt the parameter values as shown in this screen shot:

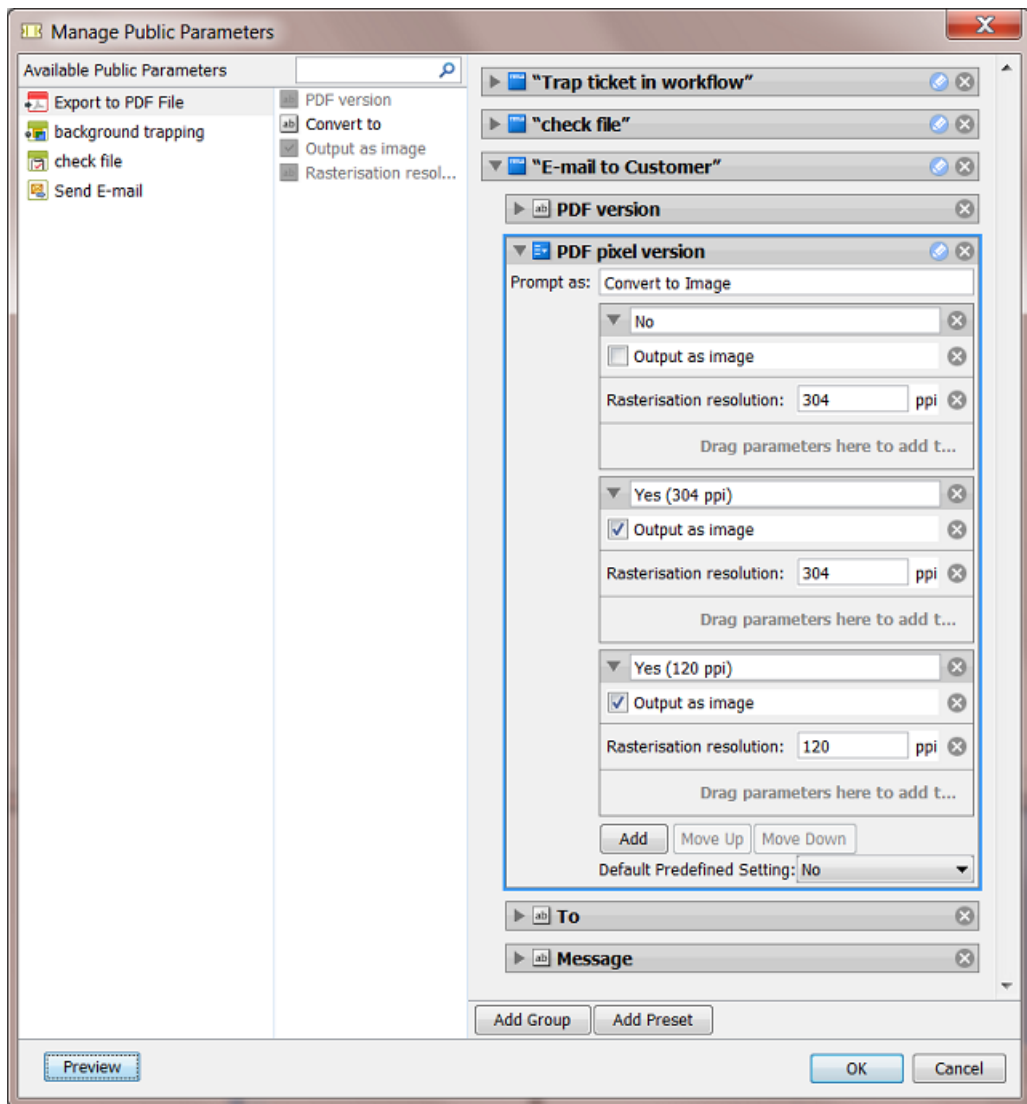

For the user launching the workflow, the resulting dialog already looks a bit simpler:

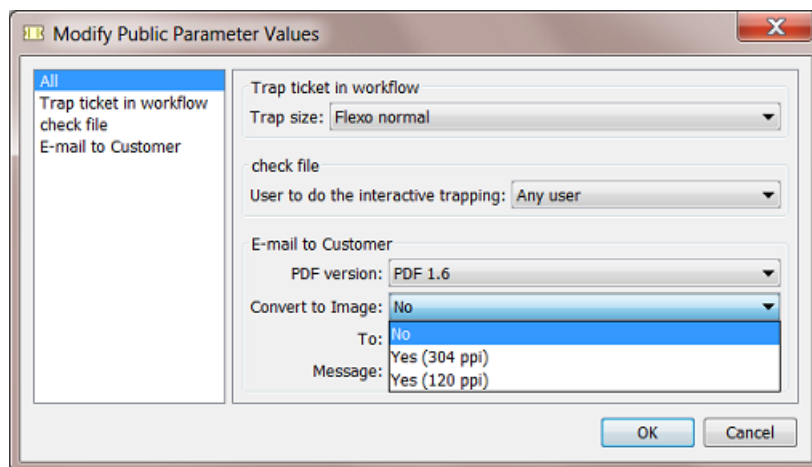

In this example, the list of parameters is not that long. That is why you could also decide to *only* offer the **All** view in this dialog. You can do this easily by moving all parameters into one group. The result can look like this:

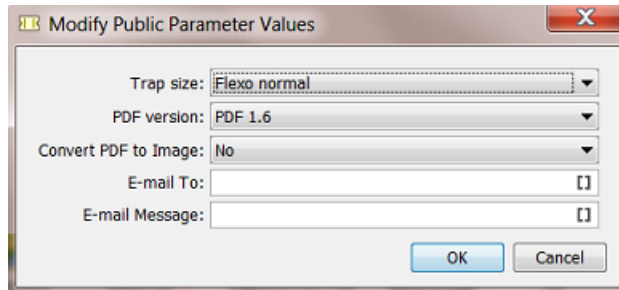

**Note:** Many tasks have Tickets with a conditional user interface: where settings depend on another setting. For example settings that only become available after you first make another choice. Example: 'Apply color conversion?'. If 'Yes', then there is the choice 'Convert to CMYK' or 'Convert to RGB'.

These kind of conditions can not be created in the **Manage Public Parameters** dialog. If you wish to recreate such a user decision, you have to create a preset that offers a choice for each combination. In our example this would mean a drop-down list with these 3 choices: 'No color conversion', 'Convert to CMYK' and 'Convert to RGB'.

### 10.5.7. Launching a Workflow with Public Parameters

Launching a workflow with public parameters is very similar to how it is done with single task tickets.

Here are some examples:

#### Example when launching from ArtPro+

In the **Launch Workflow** dialog, ArtPro+ enables to launch a task or workflow on the open file. Only public tickets will be shown and from a selected ticket, only its public parameters.

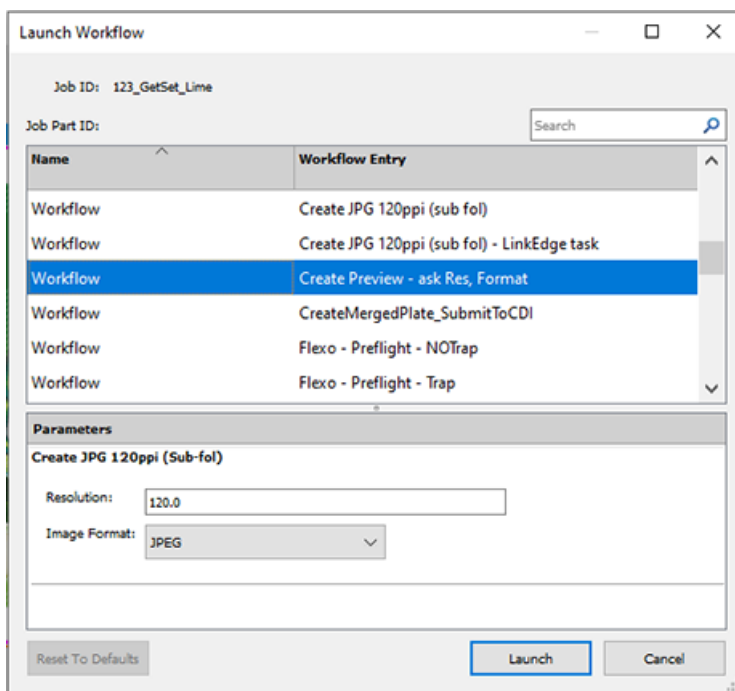

Learn more in the [ArtPro+ user guide: Working with Files > AE connection](#).

### Launching public workflows from My Workspace

Users of the simplified interface that is offered in the browser client can also launch workflows. Learn more in the chapter [Browser Client Workspaces](#) on page 886.

### Example when launching from Shuttle

Drop the input file on the workflow in the **Launch panel**.

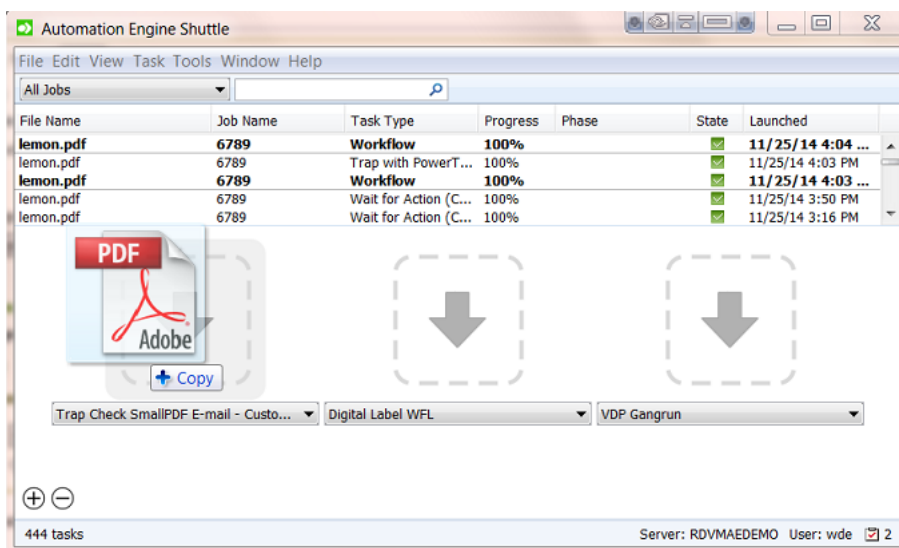

If you drop a file on the launch field of a workflow that has public parameters, a dialog will open asking you to decide these public parameters:

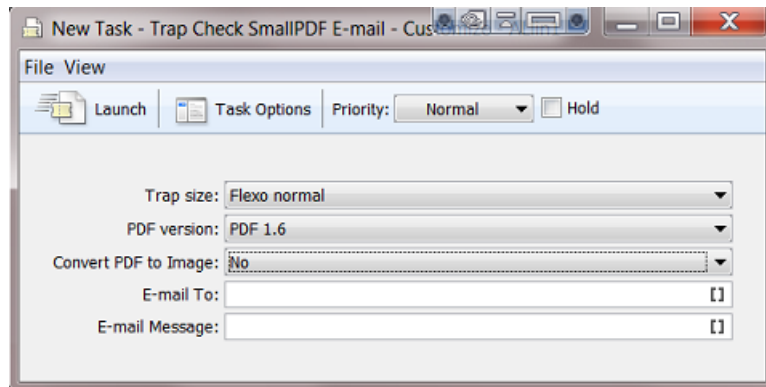

Click **Launch** when ready.

Learn more about all variants of launching workflows from Shuttle client applications in [Using Shuttle to Upload and Process Files](#) on page 107.

### Example when launching from PackEdge (legacy editor)

Choose **File > Launch Workflow** from the menu, select the workflow, decide the public parameters and press **Launch**.

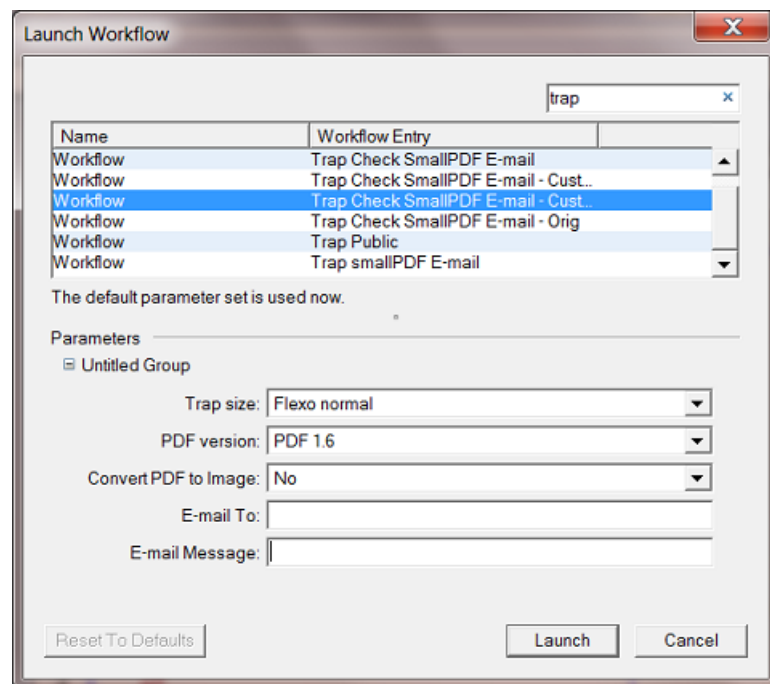

### Example when launching from ArtPro (legacy editor)

In the **Launch Workflow** dialog, ArtPro offers extra functionality to convert the ArtPro file before it enters the workflow and to set a Job or Product context (which is important when using SmartNames).



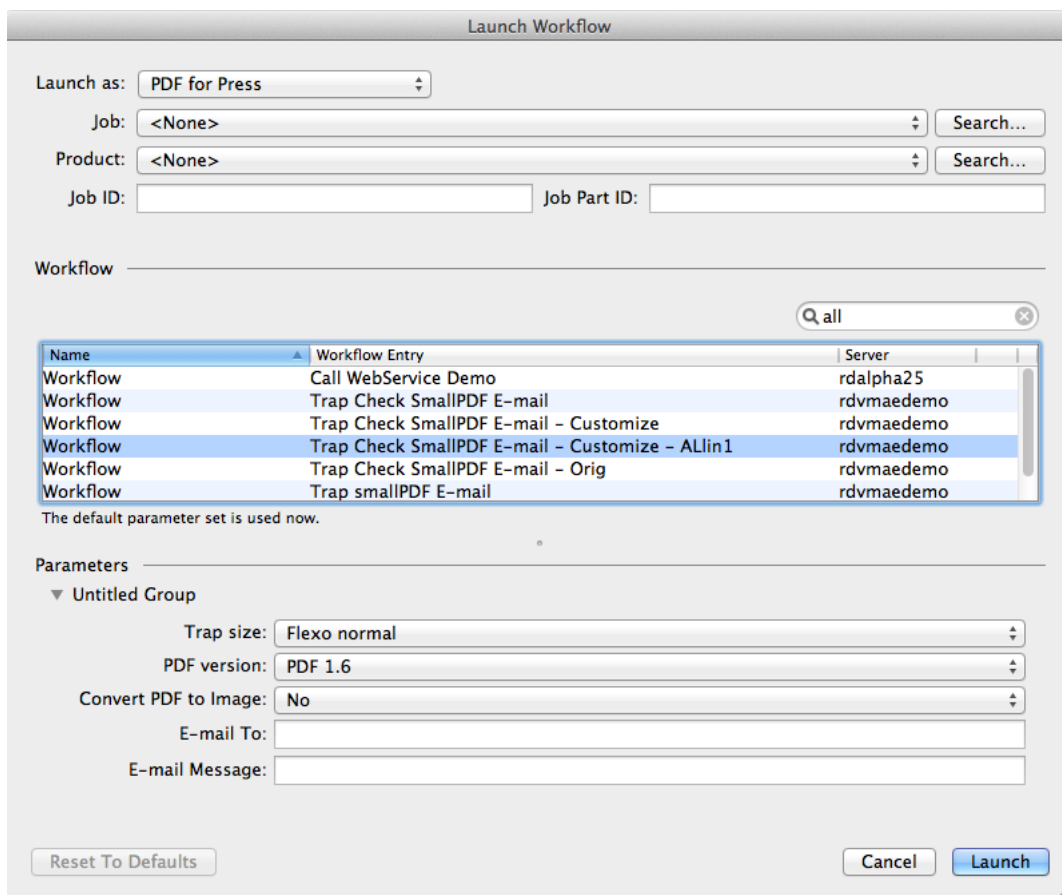

## 10.6. Using Workflow Parameters

### 10.6.1. Concept

**Workflow Parameters** are parameters that are specific for a workflow. Their values are picked up by steps in the workflow.

For example: You print displays and you mostly use the same output workflow. Your workflow ticket has 3 workflow parameters: `substrate`, `sheet size` and `quantity`. The values of these parameters can be typed in by a user or can be picked up from an external source.

Workflow parameters show up as SmartNames starting with `[wfp. ]`. Much like Job and Product parameters, you can use them by inserting them in the SmartName enabled field in your workflow steps.

In many cases, you could accomplish the same by using Job or Product parameters, but some Automation Engine customers choose to not use the Jobs or Products concept.

**Workflow Parameters are Loaded at Workflow Start-Up, but can Change Later**

Workflow parameters and their values are loaded when the workflow starts up. However they can change during the workflow. This can happen via a user intervention or more automated steps. Learn more in [reading their value from an XML file](#) and in [modifying workflow parameters during a workflow](#).

### Managing Workflow Parameters

In the workflow editor, go to **Advanced / Tools > Manage Workflow Parameters...**

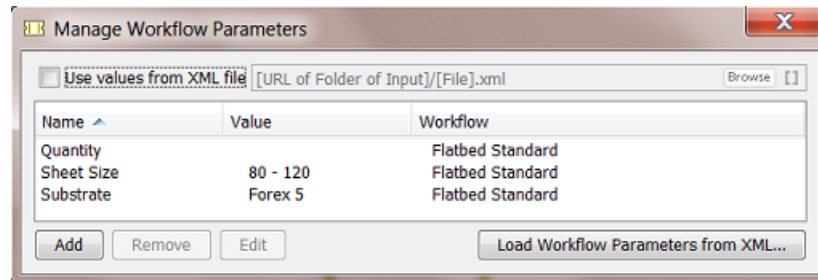

- The **Manage Workflow Parameters** dialog is where you **Add**, **Remove** and **Edit** workflow parameters.
- This dialog lists all the workflow parameters defined in the current workflow and all of its subworkflows.



**Note:** If you are in a subworkflow, the workflow parameters defined in the master workflow will not be shown in this dialog.

- You can keep this dialog open while making changes in the current or subworkflow(s) and while navigating to and from subworkflows. The list of workflow parameters is instantly updated to reflect changes.

### Workflow Parameters can be Different per Group of Files

Workflow parameters do not have to be valid for *all* files in that workflow ; they can be different per file or per group of files.

For example: The banana and lemon displays share the same `substrate` and `sheet_size`, but have a different value for the parameter `quantity`.

Workflow parameters are valid for one file or for a group of files. You can see such grouping of files when you open a Widget and select an item in its list. This will not only highlight the selected item (in blue) but also the other items belonging to that group (in light blue).



**Note:** Such a group is decided by the workflow system. It attributes "tokens" to each output file (an internal ID number). Files with a same "token" will in that part of the workflow seem to be grouped. Learn more about this concept in [Understanding Tokens \(Grouping of Output Files\)](#) on page 796.

For example: When you select `lemon.pdf`, `lemon_report.pdf` also gets highlighted. This means that they belong together in a group. This means that they share the same workflow parameters (at that point in the workflow).

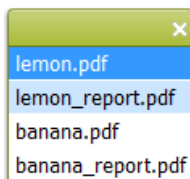

As mentioned above, these groups are created automatically by the file management logic in the workflow steps. However, sometimes a setting lets you decide how these groups need to be created. A typical example is the [Data Collector](#) on page 829.

When you right-click on an item in a widget and select **Workflow Parameter Values**, you will see the values for that group of files at that point in the workflow. An example:

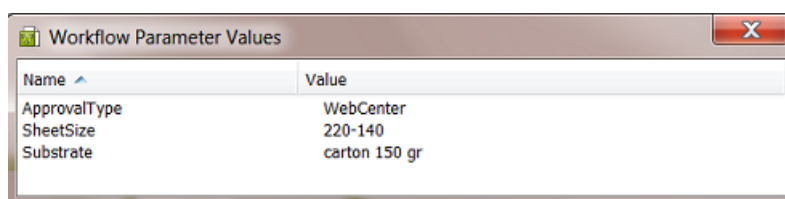

### Workflow Parameters versus Public Parameters

**Public Parameters** serve to simplify the decisions users have to make when they launch workflows from client applications. **Workflow Parameters** serve to make your workflow more automated.

Workflow parameters are also SmartNames, public parameters are not.

In the **Manage Public parameters** dialog that is shown to the user launching the workflow, workflow parameters show up as a separate parameter group named **Workflow Parameters**:

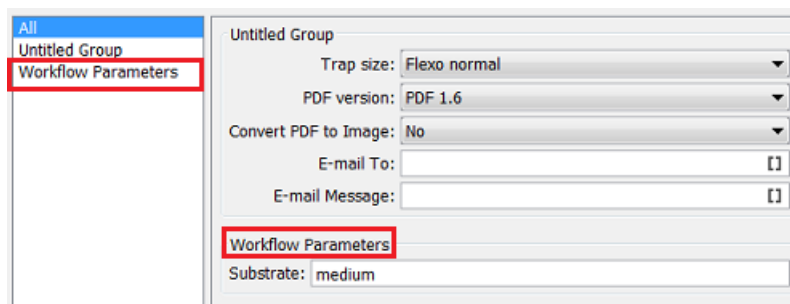

You can easily remove workflow parameters from the list of public parameters using the **Manage Public Parameters dialog**. Learn more about public parameters in [Using Public Parameters in Workflows](#) on page 838.



**Note:** There is an exception: If you [use workflow parameters values from an XML file](#), the workflow parameters will not be public.

## 10.6.2. Most Typical Use Cases for Using Workflow Parameters

### 1. Automating workflows by Loading Workflow Parameters from an XML file

This is the case where the order management or production planning system sends Automation Engine an XML with the details of the output workflow. These production specifics are automatically picked up and serve as parameters for the workflow. Learn more in [Using Workflow Parameter Values from XML](#) on page 866.

### 2. Using Workflow Parameters as a Smart Public Parameter

When users enter the value of workflow parameters manually, it usually resembles the case of a using public parameters, but then also taking advantage of the referencing power of a SmartName.

For example:

Your users need to decide if the workflow is flexo or digital. You want them to answer this one question as a public parameter:

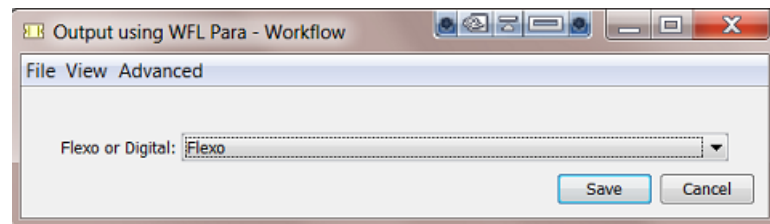

This is only 1 question but we will use the answer for 3 different decisions in our workflow, once in each of below workflow steps:

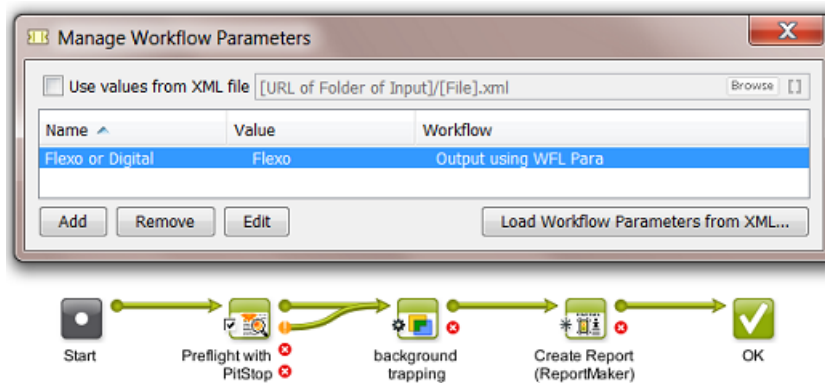

Here is an example how this can be done. We also illustrate two different levels of complexity:

- You **use the value of the workflow parameter as text**. For example the Preflight task, depending on the user's answer, uses the profile `flexo.ppp` or `digital.ppp`. In this case you pick up the workflow parameter as a SmartName:

Profile:

In the same way, the ReportMaker task uses flexo.pdf or digital.pdf as template. One decision from the user so already decided values in 2 tickets.

- You can also **use value of the workflow parameter inside another SmartName**. For example this conditional SmartName to define the trapping distance:

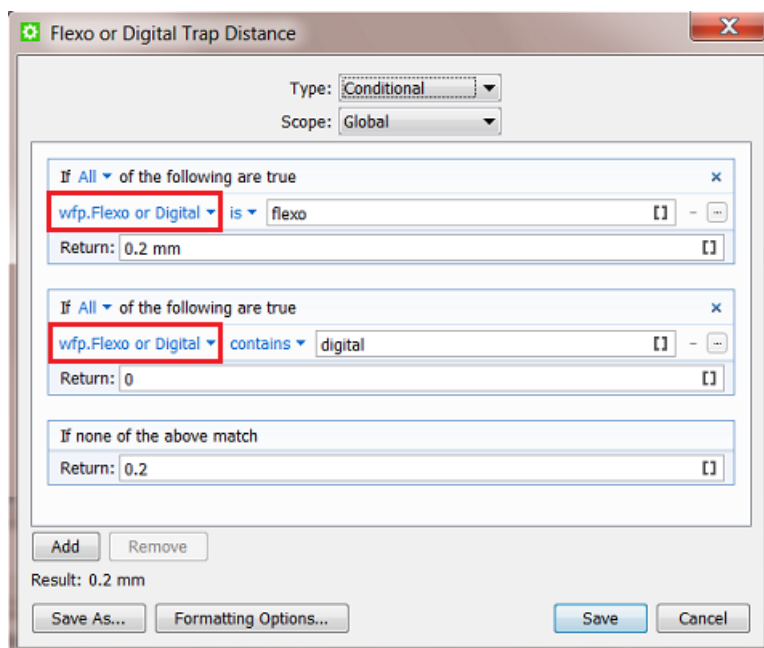

You then use that conditional SmartName in the trapping task:

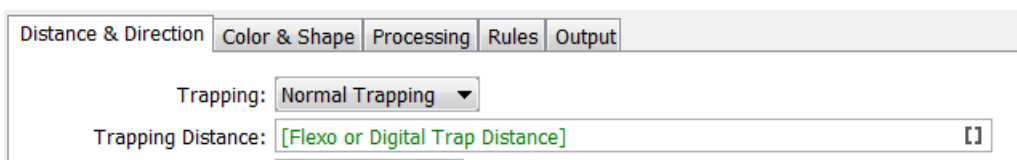

In this example, when you do not use a workflow parameter, the user launching the task would have to decide 3 different public parameters. Now, the user is only asked 1 decision.

### 10.6.3. Creating Workflow Parameters Manually

Follow these steps to create workflow parameters manually:

1. Open the (sub)workflow in the workflow editor.
2. Open **Advanced / Tools > Manage Workflow Parameters...**
3. In the **Manage Workflow Parameters**, click on **Add** and fill in the **Name** and **Value**.



**Note:** You can leave the value empty at this time. The value has to be defined at the latest by the time the workflow is launched (for example when a user who launches the workflow fills in the value in the dialog of public parameters).

In the dialog, the column **Workflow** shows if the workflow parameter is present in the current workflow or was created in a subworkflow.

Name	Value	Workflow
Approval type	WebCenter	Check Trap Proof Flatbed/Approval WFL
Sheet Size	220-140	Check Trap Proof Flatbed
Substrate	carton 150 gr	Check Trap Proof Flatbed



**Note:** If you need to add many workflow parameters and if their names are already present in an XML file, you can load that list of names by using the button **Load Workflow Parameters from XML....** Learn more [here](#).

4. Save your workflow to also save your workflow parameters.

### 10.6.4. Loading Workflow Parameters from XML

Instead of typing them in manually, you can load **Workflow Parameters** from a XML file. You can select all parameters from the XML file or only those of a specific XML Element. After loading them, you can keep the values that came from the XML file or change them.

This is an example of a valid XML file:

```
<?xml version="1.0"?>
- <job>
  - <production>
    <ApprovalType>WebCenter</ApprovalType>
    <Substrate>carton 150 gr</Substrate>
    <SheetSize>220-140</SheetSize>
    <press>SuperFlat2</press>
    <finishing>standard</finishing>
    <urgency>normal</urgency>
  </production>
  - <customer>
    <name>FruitCo</name>
    <number>2712</number>
    <currency>USD</currency>
  </customer>
</job>
```

Follow these steps to load only the items of the XML Element 'production' :

1. Open the (sub)workflow in the workflow editor.
2. Open **Advanced / Tools > Manage Workflow Parameters....**
3. Click **Load Workflow Parameters from XML....**
4. Browse to the XML file, select it and click **Open**.  
A dialog pops up asking you to specify an XML **Element** or to leave the field blank to select all items in the Root Element of the XML file.
5. In that dialog, type in the element name `production` and click **OK** to confirm.  
This will load these workflow parameters:

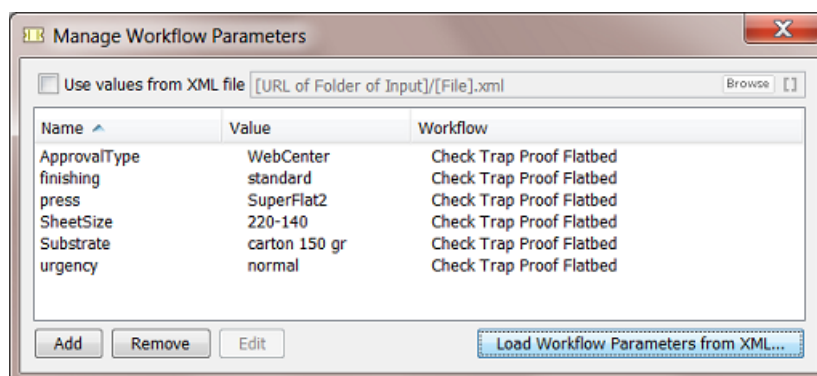

6. If you want you can make any modifications like changing a value or even removing a parameter.  
In our example, we don't need the parameter 'finishing' so we can remove it.
7. Save your workflow to also save your workflow parameters.

### 10.6.5. Using Workflow Parameters

Once you have created them, you use the workflow parameters by picking up their SmartName version in the workflow step ticket.

1. Open the (sub)workflow in the workflow editor.
2. Double-click the ticket in which you want to use a workflow parameter.

3. Click on  in the SmartName-enabled field where you want to add the workflow parameter. In the SmartNames Browser, select the **Category 'Workflow Parameters'**

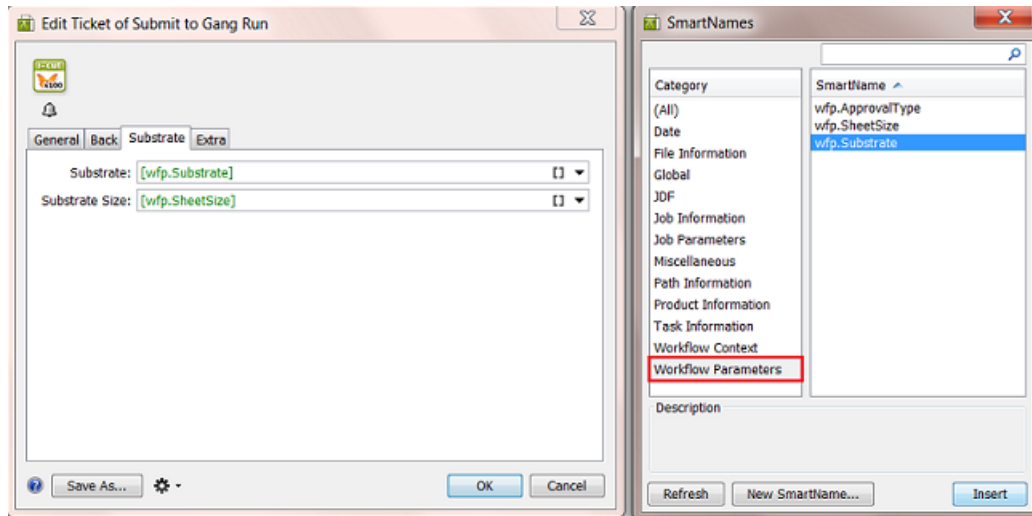

4. Select the workflow parameter [wfp. ] that you want and click **Insert** (or double-click) to add it to the ticket.
5. Click **OK** to confirm and close the ticket.
6. Save your workflow.

### 10.6.6. Using Workflow Parameter Values from XML

Workflow parameters and their values can be defined by an XML file.

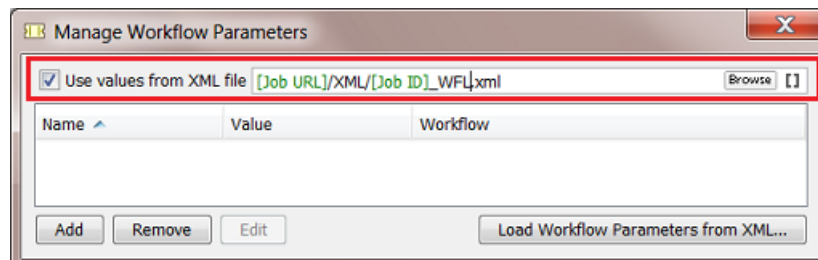

This is an example of a valid XML file:



```
<?xml version="1.0"?>
- <job>
  - <production>
    <ApprovalType>WebCenter</ApprovalType>
    <Substrate>carton 150 gr</Substrate>
    <SheetSize>220-140</SheetSize>
    <press>SuperFlat2</press>
    <finishing>standard</finishing>
    <urgency>normal</urgency>
  </production>
  - <customer>
    <name>FruitCo</name>
    <number>2712</number>
    <currency>USD</currency>
  </customer>
</job>
```

In this concept, there are 2 differences versus [creating workflow parameters manually](#) or [loading them once from an XML](#):

- the workflow will load and re-read this XML file at every step of the workflow. This also means
  - that you will probably not use the step [Modify Workflow Parameter Values](#) in this workflow because its modifications would be overruled.
  - that, during the workflow, the XML file can be updated with new or changed values.
- the resulting workflow parameters will not be public parameters. The concept here is that it is not a user who decides the values, but an XML file.



**Note:** A subworkflow gets the workflow parameters from its parent workflow that loads an XML, unless it loads values from an XML file itself.

### Example

Follow these steps to set up a workflow where workflow parameters values are used from an XML file:



**Attention:** Before we can ask a workflow to use the XML file, we first have to insert the workflow parameters as [wfp. ] SmartNames into the workflow step tickets. To be able to do that, we will first load a sample of that XML and so create these required SmartNames first.

1. Open the (sub)workflow in the workflow editor.
2. Open **Advanced / Tools > Manage Workflow Parameters...**
3. Click **Load Workflow Parameters from XML....** Browse to your sample XML file, select it and click **Open**.  
A dialog pops up asking you to specify an XML **Element** or to leave the field blank to select all items in the Root Element of the XML file.
4. Using the example XML mentioned in [Loading Workflow Parameters from XML](#), type in the element `production` in that dialog and click **OK** to confirm.  
This will load these workflow parameters and create a [wfp. ] SmartName of each of them:

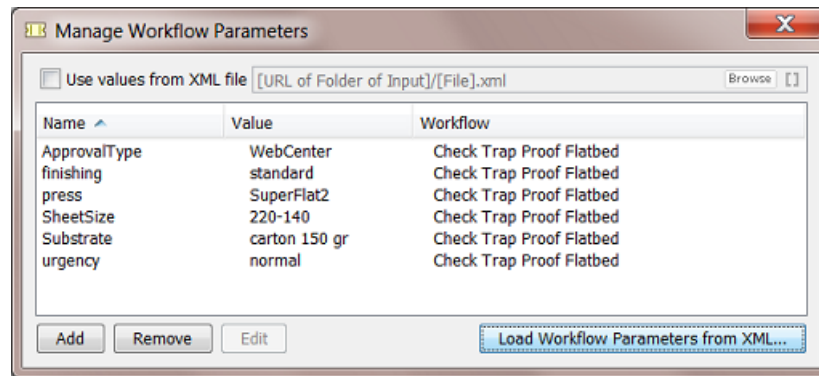

5. From that list, remove any parameters that you will not be using.



**Note:**

- The **Values** in this list will not be used anyway, they will come from the XML file (see step 7).
- The **Names** in this list are the basis for the [wfp.] SmartNames. So do not delete them if you need the SmartName version.

6. Use the resulting SmartNames in your workflow step tickets (as shown in [Using Workflow Parameters](#) on page 865).  
An example:

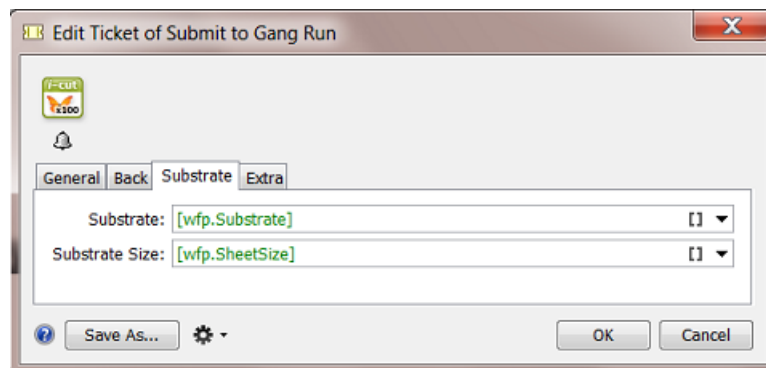

7. In the **Manage Workflow Parameters** dialog, check **Use values from XML file**. You will be asked to confirm this step. Click **OK**.
8. Select the XML file using **Browse** or use SmartNames. This is the place and name that the workflow will look for at the start of every step of the workflow.
9. Save your workflow to also save this setup of your workflow parameters.

### 10.6.7. Changing the Value of a Workflow Parameter

You can easily change the value of a workflow parameter by using the **Edit** or  (Mac) button in the **Manage Workflow Parameters** dialog.

**When would you change the value of a workflow parameter?**

When you are testing a workflow while staying in the workflow editor. You edit the parameter value, relaunch the workflow (👁️) and monitor the result.



**Tip:** When *using values from an XML file*, some administrators use this "edit and test" method to learn how the XML file should look like.

**Changing the value of a workflow parameter from a referenced subworkflow**

If you edit the value of a workflow parameter that is defined in a referenced workflow, its value will be overruled with the new value without changing that value in the referenced workflow. In the **Manage Workflow Parameters** dialog, a pencil icon ✎ will appear next to the workflow parameter that was overruled.

For example, our workflow named *Check Trap Proof Flatbed* has a referenced subworkflow named *SUBWFL Approval* in which a workflow parameter *ApprovalType* has the value *WebCenter*:

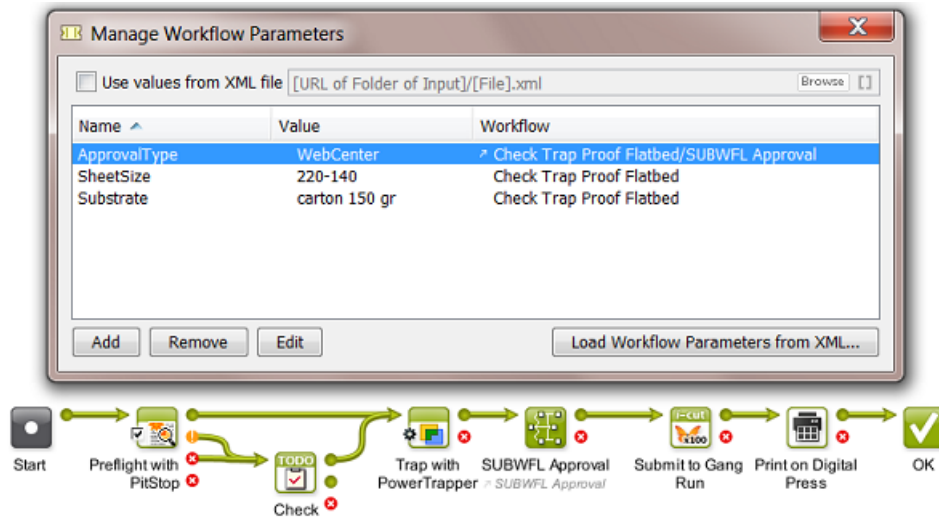

When you now edit this value, for example into *hard copy proof*, this icon ✎ will appear next to the value to indicate that this parameter was overruled:

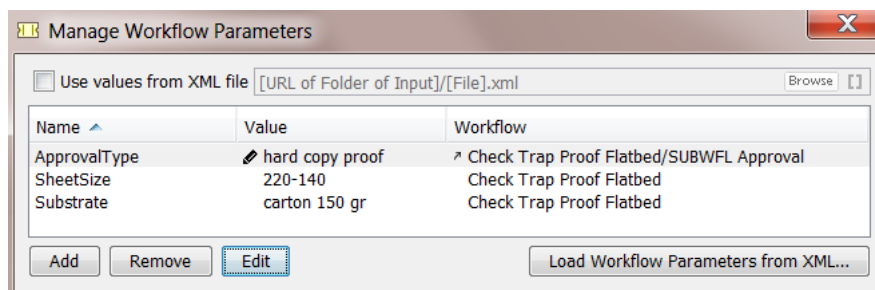

### 10.6.8. Modifying Workflow Parameters During a Workflow

The **Value** of a workflow parameter can be modified while the workflow is running. This can be done because

- the value changed or was empty before and has now 'arrived'. This change can be decided by a user or by an XML file from an external system.
- the new value did not exist yet because it is based on an result of a previous workflow step.

These workflow steps can modify workflow parameters:

- The workflow control **Modify Workflow Parameter Values**. Learn more in [Modify Workflow Parameter Values](#) on page 808.
- The **Integrate with WebCenter** task.
- The **Create or Modify WebCenter Project** task.
- The **Publish on WebCenter** task.

These WebCenter related tasks are then part of workflows that use the result of their interaction with WebCenter as a workflow parameter value in one of the next steps of that workflow.

#### Using the Integrate with WebCenter task

Some **Actions** in the **Integrate with WebCenter** task allow you to use the output of the Action to modify the value of a workflow parameter.

To do this, you need to **Map** one of the task's **Output Parameters** to a workflow parameter.

For example, a workflow asks WebCenter what the approval status is of a document and then uses that status information in the next part of the workflow:

1. In the workflow editor, in the **Integrate with WebCenter** ticket, select an **Action**. For example '**Get Document History**'.
2. Click on the Tools icon  and choose **Map Output Parameters....** A dialog will open.
3. Double-click an **Output Parameter**. For example **Document approval status**.
4. Define to which workflow parameter this **Output Parameter** needs to be mapped to. Select it from the drop-down list or from the **SmartNames Browser** or type in a (new) name. If the workflow parameter does not exist yet, you will be asked to confirm its creation.

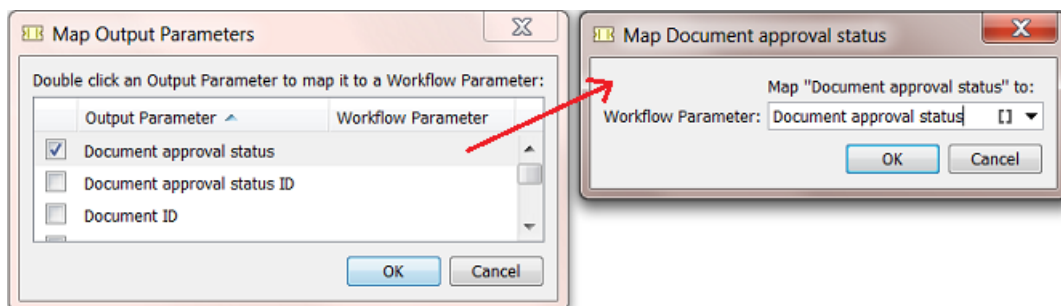

Learn more about the **Integrate with WebCenter** task [here](#).

### Using the Create or Modify WebCenter Project Task

The **Create or Modify WebCenter Project** task allows you to modify the value of a workflow parameter with the value of the **Project ID** of that WebCenter Project.

To map the **Project ID** to a workflow parameter, use the same **Map Output Parameters** dialog as explained above (point 2).

For example, you did not create the WebCenter project but you want to know the ID of this project because you will publish data to that project later in your workflow.

Learn more about the **Create or Modify WebCenter Project** task [here](#).

### Using the Publish on WebCenter Task

The **Publish on WebCenter** task allows you to modify the value of a specific workflow parameter with the value of the **Document Version ID** of the published document in WebCenter.

To map the **Document Version ID** to a specific workflow parameter, use the **Map Output Parameters** dialog, as explained as explained above (point 2).

For example:

You use WebCenter in your approval workflow. You have already published your production PDF twice to WebCenter and the customer still wants changes. You make more changes and as usual overwrite the PDF before publishing again to WebCenter.

Now the customer checks this 3rd version and changes his mind: he says that he liked version 2 better. This is a problem because nobody has version 2 any more. Remember that the document versions that WebCenter keeps are versions of only the View Data.

This can be solved when, after publishing your PDF, you ask WebCenter the document version ID and then make a copy of your production file and add that version number in its name. In this way, you also keep versions of your production PDFs.

Learn more about the **Publish on WebCenter** task [here](#).

## 10.7. Automated Launching of Workflows

---

These tools allow to launch workflows automatically:

- Access Points launch a workflow after they detected a signal from 'outside'. There are 5 types of Access Points. The Folder Access Point is the most classic example and is also often referred to as a 'hot folder'. Access Points have their own View in the Pilot.

Learn more in [Access Points](#) on page 1777.

- WebCenter can also launch workflows on Automation Engine (when they are in the same LAN). WebCenter can do this as a specific step in its own workflow, there called 'Submit Workflow'.

Learn more in the [WebCenter documentation](#). Here is a [direct link](#) to this specific topic (in v22.03).

- Some external systems can launch a workflow on Automation Engine via JDF or JMF commands. Although most of this functionality is also available through use of XML, some MIS vendors prefer to use JDF/JMF because of specific additional features.

Learn more in [What about JDF?](#) on page 1771.

## 10.8. Migrating Old Task Chains

### Old Workflow Technology

The Esko product **BackStage**, a predecessor of Automation Engine, had a limited workflow technology where workflows were only linear and were named **Task Chains**.

For example:

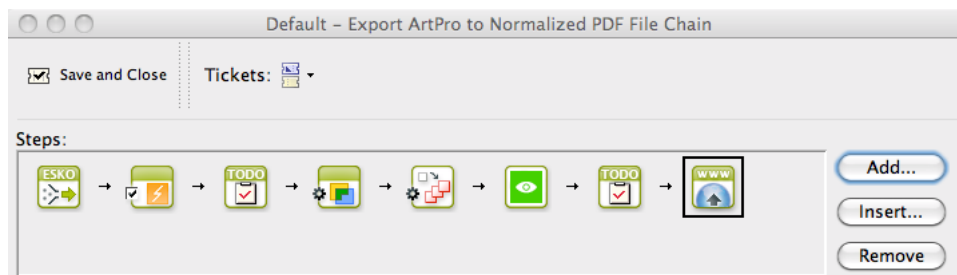

If you still have such task chains, they will still work but Esko strongly advises to migrate them to Automation Engine **Workflows**. See below how to do this.



**Note:** Depending on your version and configuration, it is still possible that your Automation Engine offers some task chains by default. Page printing workflows still offer **Export to PDF File Chain (Mark as Proof)** and **Publish Imposition on WebCenter Chain** as chains of multiple steps. Also, a 'FlexRip plus InkPlanner Chain' ticket is still available (until you can add it to a workflow with an **Imaging Engine** step).

### Migrating old Task Chains to new Workflows

You can not automatically convert task chain tickets into workflow tickets, but the workflow editor offers a tool that helps you migrating a task chain to a workflow that will keep all your settings.

Follow these steps to migrate a task chain to a workflow:

1. In the Pilot, click on **New Workflow**.
2. In the workflow editor, in the Tasks pane, select your task chain ticket.
3. Drag and drop your task chain ticket into the top part of the workflow editor window. A grey area will appear, showing you a message where to drop the ticket.

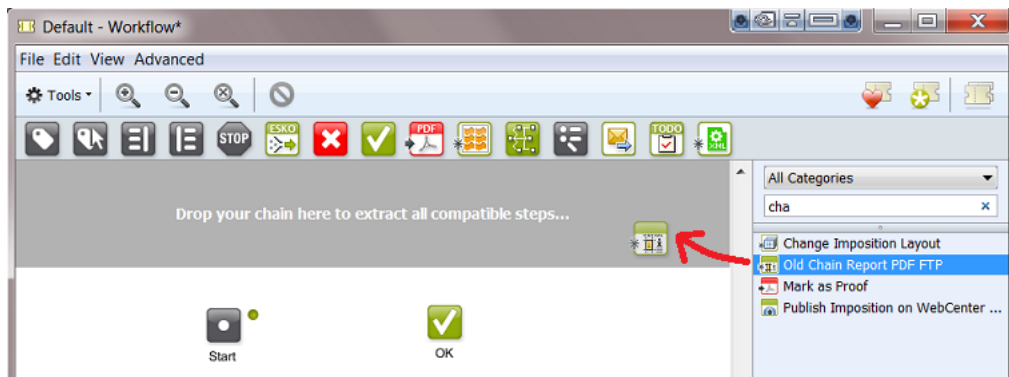

4. This starts a conversion tool that extracts all compatible steps:



- Each extracted step keeps all of its ticket settings.
- The step is named after the name of the task chain.
- The steps are not connected. You are invited to optimize your workflow construction. There may be better ways to build your workflow in the current version.





**Note:** When the chain contains "outdated" steps (FKA 'obsolete'), a warning appears:

Some chain steps will be excluded.  
Only chain steps that are compatible with this workflow system are included.

Excluded chain steps:

#	Task Type
3	Mark File

OK

When you click **OK**, the chain is migrated but the outdated step will disappear after a few seconds. This means that you should replace that step with a corresponding step that is available in your current version. For example you should replace the old **Mark File**  by **Mark** .

5. Based on these extracted steps, build your new workflow.

In below example we removed the old **Export to PDF** step because this functionality is now available on board the **ReportMaker** ticket:



6. Save your new workflow.
7. Test it and, when ready, delete the old task chain from your list of Tickets.



# 11. Working with Shuttle

---

## 11.1. What is Shuttle?

---

The Automation Engine **Shuttle** is a client tool for easy submission of files to Automation Engine workflows. Shuttle also allows monitoring these workflows.

This Shuttle technology is also integrated in classic Esko editors and in Adobe Illustrator as a DeskPack plug-in. This enables to launch Automation Engine tasks on the open file from inside these editors.

### ArtPro+

Shuttle functionality is used when ArtPro+ is connected to an on-premises Automation Engine server, and either ArtPro+ or the Automation Engine server is version 22.03 or older. Note that only launching a workflow is available: there is no Shuttle dialog to show progress of the launched jobs from within ArtPro+.

Launching the open document to an Automation Engine workflow is handled by "My Workspace" instead of Shuttle functionality

- when ArtPro+ is connected to an Automation Engine SaaS server, or
- when ArtPro+ is connected to an on-premises Automation Engine server, and both ArtPro+ and Automation Engine are version 22.07 or higher.

For more information on ArtPro+ and its connection to Automation Engine, we refer to the ArtPro+ documentation [here](#)

### DeskPack

Connection to an Automation Engine server from Adobe Illustrator is handled by the **Adobe Illustrator Client plugin**.

Shuttle functionality is used when **Adobe Illustrator Client plugin** is connected to an on-premises Automation Engine server, and either **Adobe Illustrator Client plugin** or the Automation Engine server is version 22.03 or older.

Connection to an Automation Engine workflow is handled by "My Workspace" and "Launch Workflow" instead of Shuttle functionality when both **Adobe Illustrator Client plugin** and Automation Engine are version 22.07 or higher.



**Note:** When **Adobe Illustrator Client plugin** version 22.03 or lower is connected to an Automation Engine SaaS server, you can use the **Tasks** palette to monitor tasks run on the Automation Engine server. For more information, see the Adobe Illustrator Client documentation version 22.03 [here](#)

For more information on **Adobe Illustrator Client plugin**, we refer to its documentation [here](#)

For more information on My Workspace, we refer to the Automation Engine documentation [here](#) and the Blended Learning modules [here](#).



**Note:** When this documentation was updated in 2020, all information on integrating Shuttle with legacy applications Nexus and Odystar was removed. If needed, you can still find this information in [older versions of the Shuttle user guide](#).

## 11.2. Installing Shuttle

The Shuttle is one of the client tools that you can download from an Automation Engine browser client:

In a browser, go to `http://<AEserverName>:9000/#/downloads` .

If the Shuttle application is already installed on your computer, the system will check if you have the appropriate version and download any updates if necessary.

## 11.3. Shuttle Setup

### 11.3.1. Configuring Shuttle in Automation Engine

1. In the **Pilot**, go to **Tools > Configure**.
2. Select **Shuttle**.

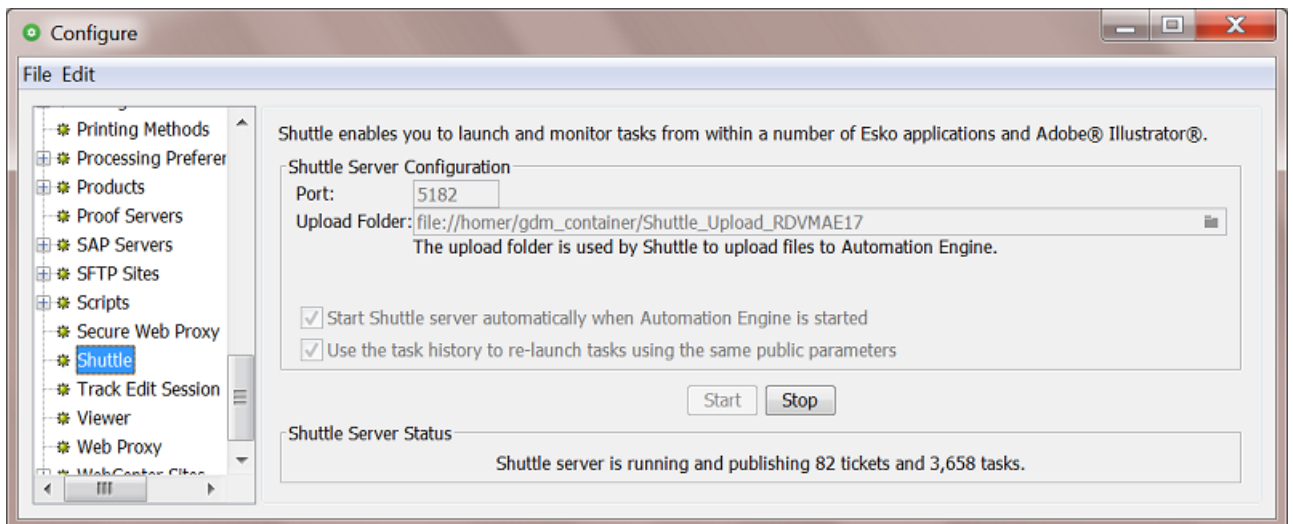

3. Enter the **Port** to use for communication between your Automation Engine server and the Shuttle clients.



**Note:** By default this is port 5182. If this port is already used by other processes, enter the next available port.

4. Click on  and select an **Upload Folder**.

This is where Shuttle clients will upload files that were not yet located in a Container, for example a file that you drag and drop from the desktop of a Mac (except the DeskPack Shuttle plug-in, that will always upload files to the **DeskPackContainer**).



**Note:** The **Upload Folder** must be located in a Container.

5. Select '**Start Shuttle server automatically when Automation Engine is started**' if you plan to make frequent use of the Shuttle technology.
6. Select '**Use the task history to re-launch using the same public parameters**' if you want Shuttle to propose to use the same public parameters when you launch a same file on the same workflow. The Shuttle then checks prior tasks, not just those shown in a Tasks overview pane but also those present in the [Task History](#) tool.
7. Click the **Start** button to start **Shuttle server**.

The Shuttle server then makes Automation Engine's workflows, tasks and files accessible to the Shuttle clients.

8. Save your settings.



**Note:** To make changes to this setup, you must first **Stop** the **Shuttle server**.

### 11.3.2. Making Tickets Public

Only Public tickets (of single tasks or workflows) can be launched from Shuttle (or from the [client applications using Shuttle](#)).

Learn about making (workflow) tickets public [here](#).



**Note:** Default tickets and (blue) Job tickets can not be made public.

### 11.3.3. Shuttle Clients connecting from Editors

1. In the editor, open the **Preferences**.

In...	go to...
<b>ArtPro+</b>	<b>Edit &gt; Options &gt; Automation Engine</b>
<b>Adobe Illustrator</b>	<ul style="list-style-type: none"> <li>• (Mac) <b>Illustrator &gt; Preferences &gt; Esko &gt; Shuttle Preferences...</b></li> <li>• (Windows) <b>Edit &gt; Preferences &gt; Esko &gt; Shuttle Preferences...</b></li> </ul>
<b>ArtPro</b>	<b>ArtPro &gt; Preferences...</b> or use <b>Command + K</b>
<b>PackEdge/Plato</b>	(Windows) <b>Edit &gt; Preferences &gt; Server&amp;Resources</b>

In...	go to...
<b>FastImpose Standalone</b>	<b>Tools &gt; Shuttle Preferences...</b>

2. Fill in the name of the Automation Engine server.
3. Enter your **User Name** and **Password**.

Enter a **User Name** and **Password** that is also valid to sign in to a Pilot.

You will have the same access rights in Shuttle as you have in the Pilot (for example the right to change processing priorities).

### 11.3.4. Shuttle Application connecting to Automation Engine

1. Launch the Shuttle application.
2. You will be asked to sign in to an Automation Engine server

Sign in in the same way as you would do for a Pilot. Learn more in [Signing In to the Pilot or Shuttle](#) on page 76.



**Tip:** If, on that same computer, you are already signed in to a Pilot or another Shuttle client (possibly from within an editor), the system will check what you selected in **Pilot > Configure > Login automatically with user name and password from other application connected to the server**.

## 11.4. Launching the Automation Engine Shuttle

---

When you launch the Shuttle application, the window shows a list of launched **Tasks** and a **Launch Panel** where you can define one or multiple drop areas that each launch a specified workflow:

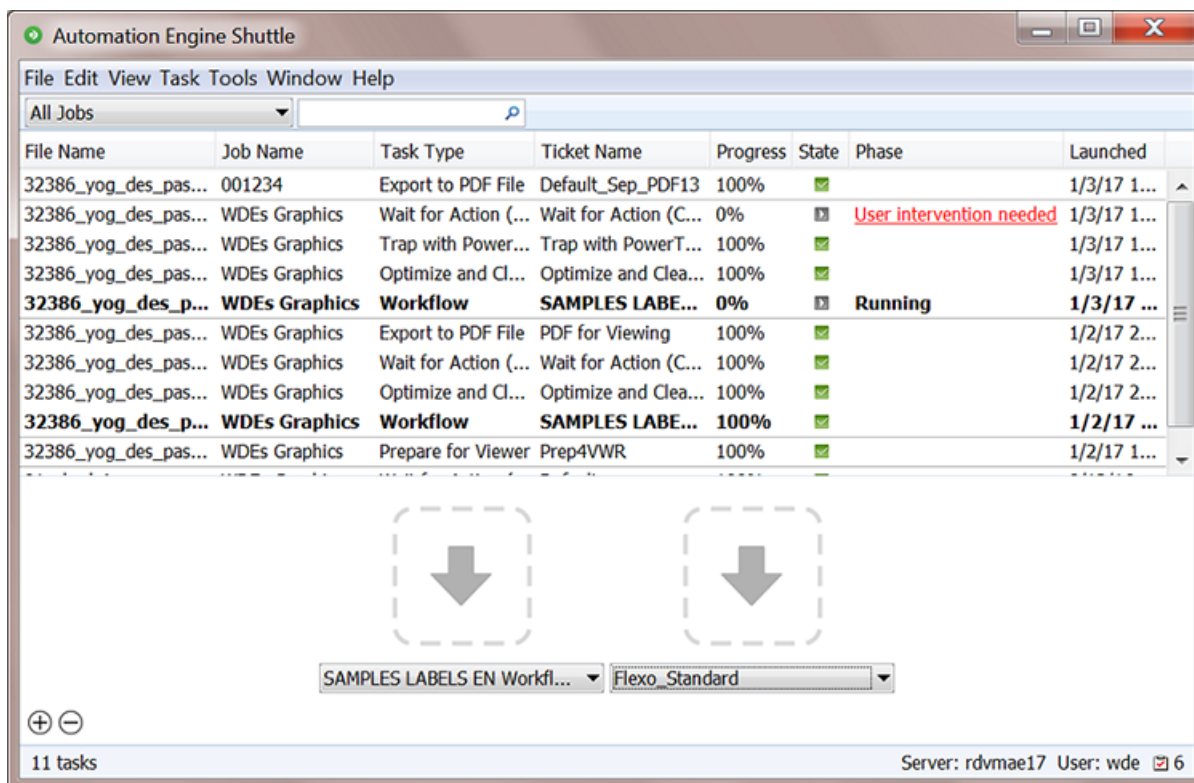

- To open a new window, go to **File > New Window**. You could use dedicated Shuttle windows for each of your Workflows.
- Use the **View** menu to hide or show parts of this window:
  - **View > Tasks** hides/shows the Tasks panel.
  - **View > Launch Panel** hides/shows the Launch panel.
  - **View > Status Bar** hides/shows the Status bar indicating the progress.
- When closing, Shuttle saves the settings of the windows.

## 11.5. Working with the Automation Engine Shuttle

Starting the Shuttle will ask you to login to the Automation Engine server.



**Note:** Whether this user can also start up a Pilot is decided by a specific **User Access Right**. Learn more in [Access Rights](#) on page 157.

### Menu items

- **File:** To launch one or more files on the one defined workflow (after browsing for files), or to open and close Shuttle windows.
- **Edit:** To cut, copy or paste text in the search field. To select and delete tasks. Or to define **Preferences** (see below).

- **View:** To show or hide the Tasks pane, the Launch panel and the Status Bar.
- **Task:** To open or show the output file of the selected Task, to release or cancel the Task, or to add Annotations and show the task's Details.
- **Tools:** To open the **To Do List**.
- **Window:** To minimize, zoom or switch between Shuttle windows.
- **Help:** To see the **About** window or to access this online documentation.

### Setting the Preferences for Shuttle

On Mac, select **Preferences...** in the **Application** menu. On Windows, go to **Edit > Preferences...**

In the **Preferences** dialog, set the units for **Dimension**, **Resolution**, **Ruling** and the number of **Decimals** to use.

Select '**Always show launch dialog**' if you want to see the **Public Parameter** dialog when starting a new task, even if there aren't any public parameters. This allows you to change these parameters before launching the task.

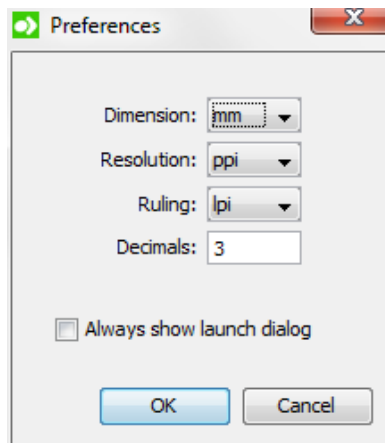

### 11.5.1. The Tasks Panel

The **Tasks** panel is the part that shows the Automation Engine tasks that were launched both from Shuttle and Pilot clients. One row represents or a single task or one step of a workflow.

You can filter the displayed list tasks:

- By filtering on a Job context from the Job selected from the drop-down list in the toolbar.  
Select **Other...** if you want to select a Job other than the recently used ones in the list. Select **All Jobs** to clear the current filter.
- By typing in a value in the filter. Learn more about creating filters in [Using Filters](#).



**Note:** In Shuttle, you cannot open or edit a task. This is only possible in a Pilot.



**Tip:** You cannot hide the columns displayed in the Task's pane. However, you can change their order and width.

### Tasks asking for User Intervention

Workflows that including a [Wait for Action](#) task will show when they reached this step in the column **Phase**. This allows the Shuttle user to intervene and decide how the workflow continues.

File Name	Job Name	Task Type	Progress	Phase	State	Launched
OmNom.ai	mabm	Wait for...	0%	User intervention	▶	10/30/12 5:15...
OmNom.ai	mabm	Workflow	0%	Running	▶	10/30/12 5:15...
Screen Shot 20...		Wait for...	0%	User intervention	▶	10/30/12 5:14...
Screen Shot 20...		Workflow	0%	Running	▶	10/30/12 5:14...
arrow.png		Workflow	100%		✖	10/30/12 10:5...
arrow.png		Workflow	100%		✖	10/30/12 10:5...
Screen Shot 20...		Wait for...	0%	User intervention	▶	10/30/12 9:16...
Screen Shot 20...		Workflow	0%	Running	▶	10/30/12 9:16...

To intervene,

- Click on the **User intervention needed** link.
- In the resulting **To Do** window, choose to **Forward** or **Release**. Learn more in [User Intervention managed from Shuttle](#) on page 884.

### Context menu options

Right-click on a task to access these options:

- **Open Output File:** To open the task's output file with the appropriate application (if possible).
- **Show Output File in Finder / Explorer:** To see the folder that contains the output file in (Mac) Finder or (Windows) Explorer.
- **Release:** To release a task that is on hold.
- **Cancel:** To cancel a running task.
- **Delete:** To delete a finished task. You will be asked to confirm.
- **Annotation...:** To add or modify an annotation.
- **Details:** To see a dialog with detailed information about the task (step).



**Tip:** These options are also available via the **Task** menu.

## 11.5.2. The Launch Panel

The Launch Panel is where you drop one or multiple files as input files for that workflow. Each drop area is indicated with a large arrow and serves to launches one selected workflow.

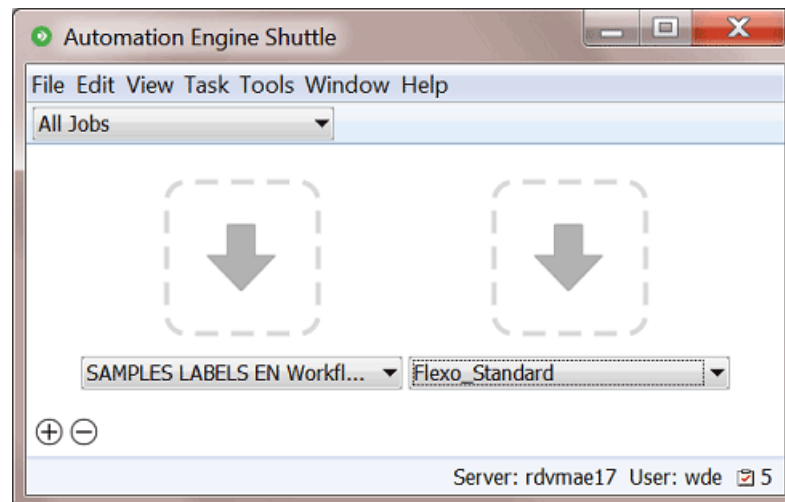

- Click ⊕ to add an extra drop area.



**Note:** To remove a drop area:

- Click ⊖. This changes the user interface in editing mode.
- Click ✕ on the top left corner of the drop area that you want to delete.
- To leave the editing mode, click again on ⊖ or press **Escape**.

- Below each drop area, select the desired workflow from the drop-down list.



**Attention:** Only **Public** tickets are listed.



**Note:** The drop areas and their assigned workflow are saved when you close Shuttle.

### 11.5.3. Launching a Workflow from the Automation Engine Shuttle

1. If the Launch Panel is not visible in the Shuttle window, go to **View > Launch Panel**.
2. Submit one or more files in one of these ways:
  - Drag and drop the desired file(s) onto a drop area.
  - Go to **File > Launch...** and select the files.
  - Use the keyboard shortcut **CMD-L** (Mac) or **Ctrl-L** (Windows) and select the file(s).





**Note:**

- If a file was previously launched on the same workflow, a dialog will open and ask if you want to reuse the public parameter values from the previous launch. If you choose to reuse these values, they will be used as default parameter values. You can still edit these values if necessary.
- The selected file(s) will be uploaded to the root folder of the selected Job. When no Job is selected, it will be copied to the **Upload Folder** defined in the [Configure panel](#).
- If a file with the same name is already present in the upload folder, a dialog will warn you about overwriting the file. You can then choose to either **Replace** the existing file, or **Cancel** the launch.

3. If the workflow has Public Parameters, the **New Task** dialog will ask you to fill them in. Learn more in [Using Public Parameters in Workflows](#) on page 838.

An example:

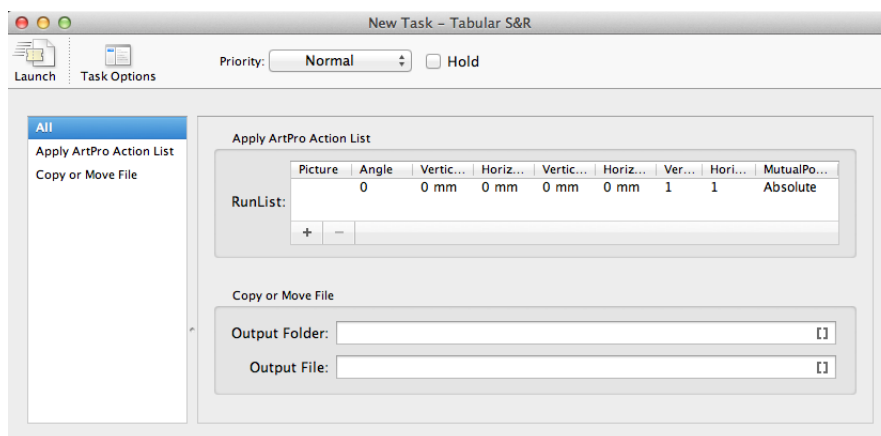

a) Click **Task Options** to define general task options. You can:

- Set the **Priority** of the task (**Low**, **Normal**, **High** or **Immediate**).
- Select **Hold** to keep the task from being launched until someone releases it (via a right-click or via the **Task** menu).

Alternatively, use **'Release at'** to hold the task until a specific time, after which it will automatically be released.



**Note:** You can later change this automatic release setting by selecting **Release** via the right-click menu in the Tasks panel or via the **Task** menu.

- Select **'Launch a separate Task per input file'** to launch a separate task or workflow for each input file.
- You can also set an **Annotation** for the task.

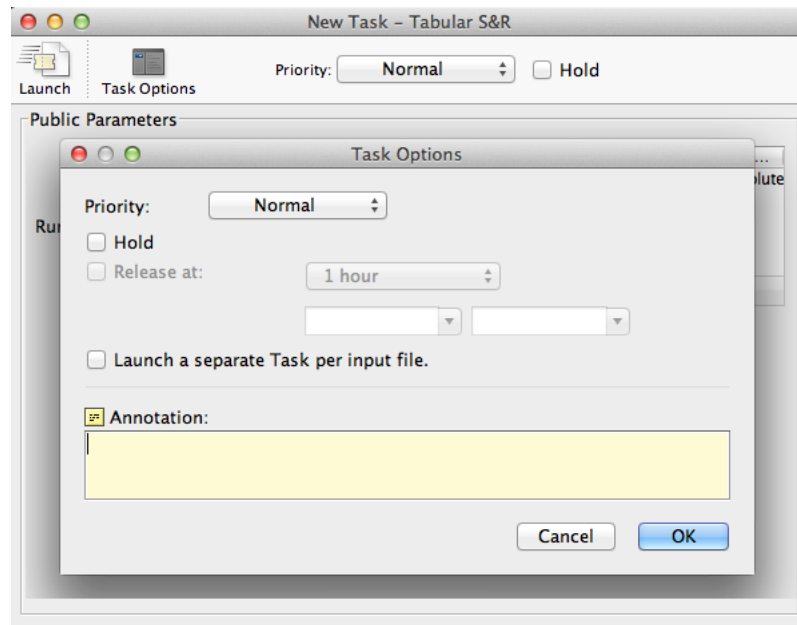

4. Click **Launch** to launch the workflow.  
The task will immediately appear in the Tasks panel.

### 11.5.4. User Intervention managed from Shuttle

When the launched workflow contains a *Wait for Action (Checkpoint)* step, a **User intervention needed** link appears in the Tasks panel when that workflow step is reached..

1. Click on the **User intervention needed** link to open the **To Do** dialog.

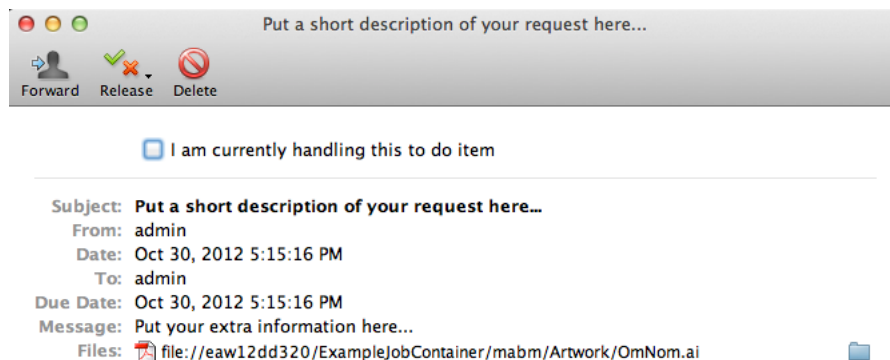

2. Optionally, select **'I am currently handling this to do item'** to mark that you are handling this item (other users are so also informed).
3. Decide how you want to **Release** this item. The offered choices are those that were decided in the ticket of the 'Wait for Action (checkpoint)' task.  
Select the wanted output state. The **To Do** window will close and the workflow will continue processing.

4. In stead of releasing the item, you could **Forward** or **Delete** it.
- Click **Forward**, choose the user and set other details. The other user then needs to decide how and when the workflow continues.
  - Click **Delete** to delete this item and also end the processing of the workflow.

# 12. Browser Client Workspaces

## 12.1. Introducing the Browser Client

### Working with Automation Engine from within a web browser

In stead of using Automation Engine via the Pilot, you can also do this from your favorite web browser. Compared to the Pilot, it offers less functionality in a much simpler user interface.

The daily user of browser client uses the configuration that was set up by an administrator user using the Pilot.

Its functionality is bundled in 'workspaces'.

### Using Workspaces, Downloading apps and some specific Admin tools

A browser client's home page offers these menu items:

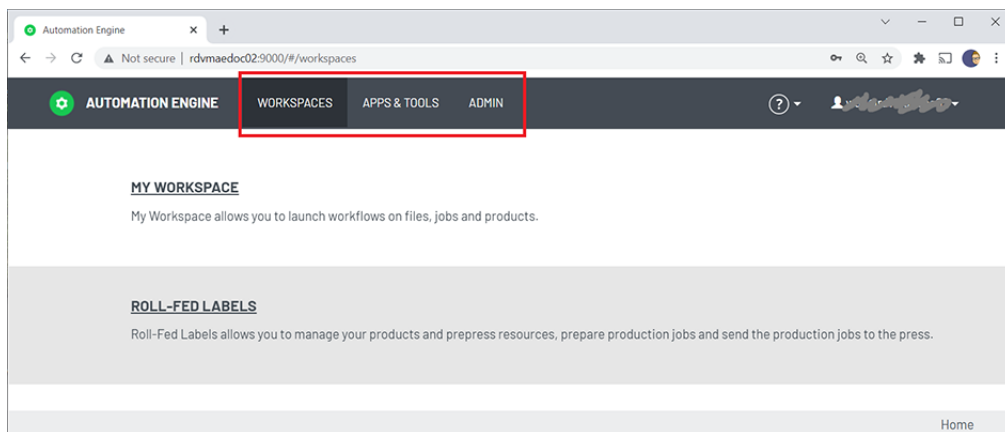

- **Workspaces:** For daily usage by prepress users. Learn more below.
- **Apps & Tools:** Come here to download other client apps or other tools.
- **Admin:** Some very specific admin tools.



**Note:** You may notice that most of AE's admin tools are available in the [Server Admin](#) pages. But because those pages are unavailable to SaaS users, we here offer some specific admin tools that also SaaS users can set from their location.

### Workspaces

In the browser client, a **workspace** is a tailored user interface.

By default, signing in will take you to the generic client workspace called **My Workspace**.

Depending on your licenses, signing in to the AE browser client may show you more than one workspace. When you also see the workspace **Roll-Fed Labels**, this means you also have the licenses for the product formerly called "Automation Engine QuickStart for Labels".

When you have licenses for more than one client workspace, you can switch to another workspace by clicking on the icon of Automation Engine in the top bar and then selecting the workspace you want.

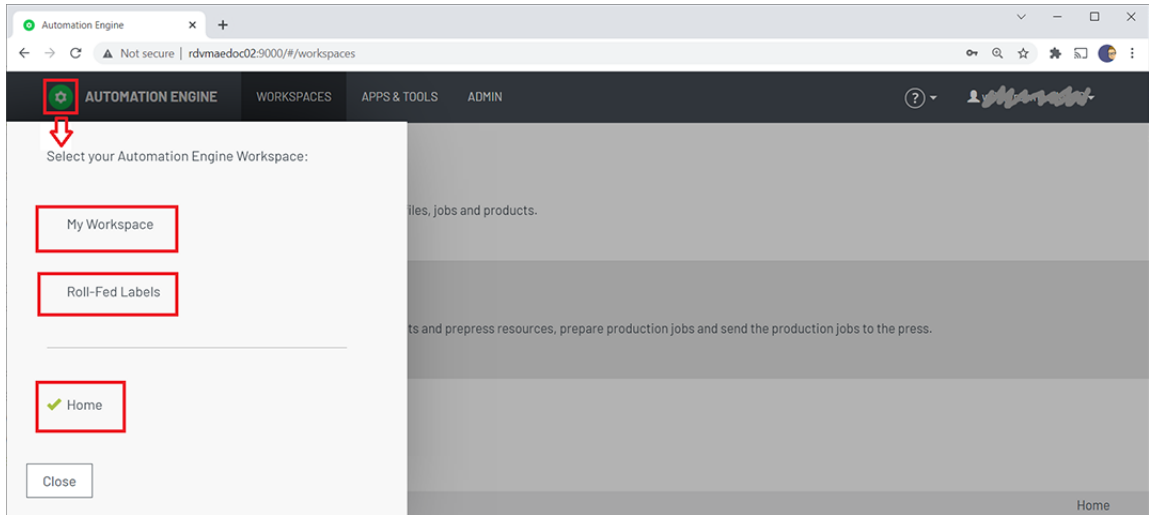

Workspaces share a user's authentication and his user preferences.



**Note:** Technically, these workspaces are different web applications of Automation Engine. Also notice how, once selected, they have their own URL (page).

## 12.2. Browsing to your AE server

### 12.2.1. Signing In

#### Browser Client URL

In a browser, go to `http://<AEservername>:9000/`

Which browsers are supported is described on [www.esko.com/systemrequirements](http://www.esko.com/systemrequirements) # **Automation Engine > Browser Based Client.**

#### Signing In

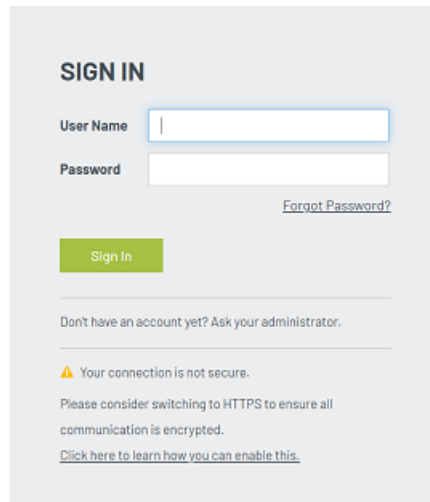

### About HTTPS

HTTPS is the preferred way to connect. It ensures that all communication is encrypted.

The sign in page will detect if your connection is not secure, i.e. if your network is using HTTP and not HTTPS. The page will mention this and advise you to switch to using HTTPS. It also refers to [this KB article](#) that explains how this can be done.



**Note:** On the AE server computer, go to the Server Config page <http://localhost:9897/> # **Browser Client** to see or configure the used port and whether HTTP or HTTPS should be used.

### Automatic Sign Out

A browser session will automatically sign out

- when the page is open: after 2 hours.
- when the page was closed: after 10 minutes.

## 12.2.2. Can I Use Domain Users?

Yes you can.

You need to set this up on the Automation Engine server using Windows User Management tools.

A domain user can be used when you add it to the Windows users group 'BGusers' or 'BGadmin'.

To see these domain users appear in the browser interface (**Admin > Users**), just wait 15 minutes, or restart the 'bgmd' service.



**Note:** Domain users with the same user name as the local user can exist.

### 12.2.3. Can I use the Browser Client from Outside my Network?

- No.  
The (browser) client computer must be in the same LAN as the Automation Engine server.
- Yes.  
In an AE SaaS setup, the AE server is in a data center, then of course the client can be in a different network location. The communication then happens via HTTPS.  
Learn more in the chapter on [AE SaaS](#).

## 12.3. Basic features used in every workspace

---

### 12.3.1. Advanced ways to Search and Filter

There are more advanced ways than those described in the eLearning modules.



**Important:** This page assumes that you have seen the modules that illustrate the basic sorting and filtering in your workspace.

In the eLearning modules, we show that you can type in a value and that you can select a category to restrict the search to only that category. The selected category is then also added to the text in the search field. We also show an example where we manually add a combination of categories and values.

#### Rules and Possibilities when Typing in Filters yourself

We here repeat the main rules and add some extra possibilities and examples.

- In the search field, categories always need to be followed by a ':' . For example: '**state:run**' .
- When the name of a category contains spaces, you must put it in between quotes. For example: "**order material**".
  - Alternatively, some categories can also be written without spaces. For example: for "**due date**", you can also write **duedate** .
  - For "**production job name**", or "**product name**", you can even simply write **name** .
- To have an exact match with the word behind the category, you must place a '=' right after the ':' . For example: "**production job name**":=**blond** . This will find the job '*blond*' but not the job '*blond\_2018*' .
- You can type the name of a category in English or in its translated version.
- When the product or job setting contains '*word1*' immediately followed by '*word2*', you can enter "**word1 word2**" or **category:"word1 word2"** .
- When these 2 words do not appear next to each other or are not even in a same category, you can enter **word1 word2** or **category:word1 category:word2**. For example: **60 fruitco** or **name:60 customername:fruitco** .
- When the category name is not recognized, it is treated as regular text.

- When you search for a word that ends with a ':', put it between quotes to avoid that it is treated as a category.
- The search field is not case-sensitive.

### More Ways to Filter on Date

As shown in the eLearning modules or workspace 'Roll-Fed Labels', you can for example filter on the creation date of products and on the creation or due date of production jobs. In the workspace 'My Workspace', you can search a file by its modification date or a Job by its due date, etc.

- What you enter in the search field must comply with one of these three formats:
  - day, month and year
  - day, month, year and time in minutes and seconds
  - month
- The text of the date also depends on the language that you have chosen in **User > My Preferences**.
- Examples of supported dates:
  - English:
    - 08/28/2017
    - 8/28/2017
    - "August 28, 2017"
    - "Aug 28, 2017"
    - "August 28, 2017 4:25 PM"
    - "Aug 28, 2017 4:25 PM"
    - "Monday, August 28, 2017 4:25 PM"
    - "Mon, Aug 28, 2017 4:25 PM"
    - August
    - Aug
  - French:
    - 28/08/2017
    - 28/8/2017
    - "28 août 2017"
    - "28 août 2017"
    - "28 août 2017 16:46"
    - "28 août 2017 16:46"
    - "lundi 28 août 2017 16:46"
    - "lun. 28 août 2017 16:46"
    - août
  - German:
    - 28.08.2017
    - 28.8.2017
    - "28. August 2017"
    - "28. Aug. 2017"
    - "28. August 2017 16:48"
    - "28. Aug. 2017 16:48"
    - "Montag, 28. August 2017 16:48"
    - "Mo., 28. Aug. 2017 16:48"



- August
- Aug.
- All date formats that contain spaces need to be put between quotes.
- Partial date formats are not accepted.
- Entering a date in one of the above formats without specifying a category will also search for the date in all non-date settings of the product or job (as plain text).
- Next to dates, you can also use the words '**yesterday**', '**today**' and '**tomorrow**'.
- When filtering based on a month, only products or jobs with a creation or due date within that month of this year will be found.
- You can combine filtering on dates with filtering on other types of settings.

### 12.3.2. User Preferences

In the top menu bar, click on the name of the signed-in user and choose '**My Preferences**'.

- **Color Theme** (light or dark mode).

The default setting is '**Let browser decide theme**'. When this choice is selected, the user interface of this browser client will be displayed in light mode unless the browser itself has a general setting regarding its color theme. In that case the workspaces will be in dark mode.

- Example: The browser Safari 12.1 on macOS Mojave (10.14) will, with this setting, appear in the dark color theme when the macOS is set to 'Appearance Dark' in the system preferences.
- **Language**: Select the language of the user interface of this browser client.
- Select the preferred unit for these attributes in this browser client: **Dimension, Resolution, Ruling, Weight, Decimals**.
- **Reset All Dialog Warnings**: See this illustrated in the [eLearning course about 'My Workspace'](#) in its module '[Launching Workflows](#)' (section 'Launching in a Job Context', slide 191).

## 12.4. Workspace 'My Workspace'

---

### 12.4.1. Concept

#### Most Functionality for Daily Use, in a Web Browser

In stead of using the Pilot, you can use a browser to connect with the Automation Engine server and get a simplified client user interface.

This browser client does not offer all functionality that is available in the Pilot.

Its target user is a regular user who can access Jobs and Products data, launch and trace workflows and manage the to do list.

The Pilot is where an administrator will have created the workflow tickets and have set up all configuration.

All standard browsers are supported. Find details on [www.esko.com/systemrequirements](http://www.esko.com/systemrequirements).

You can use the browser client both for an AE On-Premises server as for an AE SaaS server. Learn about the difference in [On-Premises or SaaS](#) on page 34.

### 12.4.2. See the eLearning Modules

"My Workspace" is explained with a dedicated course on the Esko Blended Learning platform.

Click [here](#) for the eLearning course "**Automation Engine – workspace My Workspace**".

This course contains these modules:

- Introduction
  - What?
  - Access and first views
- Basic Data Management
  - Main navigation, filtering and file management within the pages Files, Jobs, Products
  - Jobs and Products parameters are shown but are read-only
- Opening Files from a Browser
  - How the Esko App Launcher allows you to open files from your browser in a default or selected local application
- Launching Workflows
  - Basic Use
  - Public Parameters and how your administrator can make you a custom interface
  - Working in and out of a Job context
- Drop File page
  - Concept (replacing the standalone application 'Shuttle')
  - Basic Use
  - Launch Without a File
  - Data management & FAQs
- Activity page
  - Trace and inspect launched workflows
  - Relaunch workflows with same or different files
- To Do page
  - Manage or forward to-dos (created by workflows asking your intervention)

### 12.4.3. Jobs page



**Important:** Please first see the related [eLearning Modules](#).

Some extra notes:

- The Jobs table is read only.
- It is updated live.
- This view only shows Jobs with a location attribute that the current user is allowed to see. (Jobs without a location attribute are always shown). Learn more in [Locations](#) on page 220.



**Tip:** Any [Smart Views](#) that were created in the Pilot will also show up for this similar page in My Workspace (browser client).

### 12.4.4. Products page



**Important:** Please first see the related [eLearning Modules](#).

Some extra notes:

- The Products view is read only.
- It is updated live.
- This view only shows Products with a location attribute that the current user is allowed to see. (Products without a location attribute are always shown). Learn more in [Locations](#) on page 220.



**Tip:** Any [Smart Views](#) that were created in the Pilot will also show up for this similar page in My Workspace (browser client).

### 12.4.5. Context Selection tool

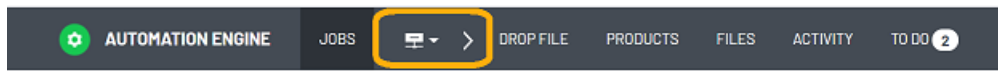

**Important:** Please first see the related [eLearning Modules](#).

Some extra notes:

- This button serves to switch between 'Containers' context and a Job context.
- The arrow to its right indicates that all views on its right are affected by the selected context.

### 12.4.6. Drop File page



**Important:** Please first see the related [eLearning Modules](#).

Some extra notes:

- The maximum number of drop zones (including the default drop zone) is 64.
- The default drop zone can not be removed or re-arranged.

### 12.4.7. Files page



**Important:** Please first see the related [eLearning Modules](#).



**Important:** In the Files view, a message pops up when a user tries to open a Job folder or Product Data Zone for a Job or Product where (s)he is not assigned to the location of that Job/Product. Learn more in [Locations](#) on page 220.

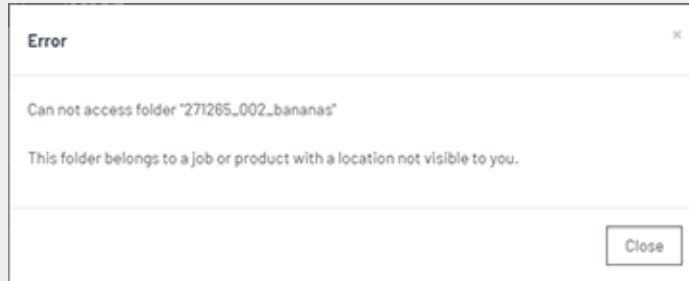

## Opening Files from the Browser Client

### Concept

For security reasons, web browsers refuse to open files in another local application, at least until you give your explicit permission. Also in the AE browser client, the first time you request to open a file, your browser will first ask you if you agree that it opens another application.

Much like in the AE Pilot, you have 2 choices:

- **'Open'** is asking to open the file in the application that this client computer uses by default for this file type. For example: a client computer that by default opens a PDF in Adobe Acrobat.
  - To change this behavior, you need to change that file type association setting on that client computer.
- **'Open With'** allows you to choose a (non-default) application (one that was registered?)

### 'Open'

Browsers show small differences in how they react to this request (below examples were taken on a Windows10 client).

On each client computer, the first time you select a file and choose 'Open', your browser will react with this question:

- **Google Chrome.** Chrome opens this dialog (we blurred out the name of the AE SaaS server):

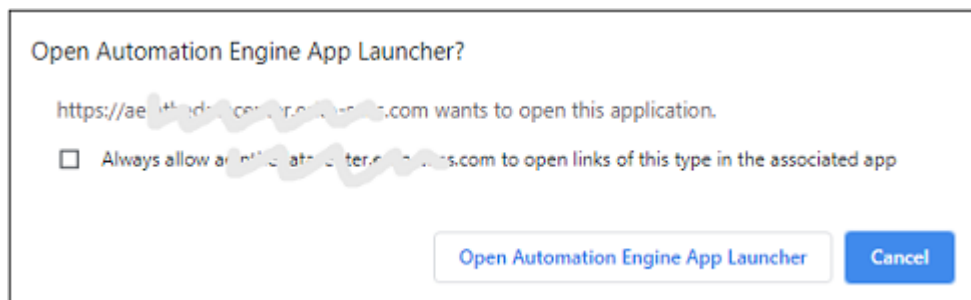

- **Mozilla Firefox.**

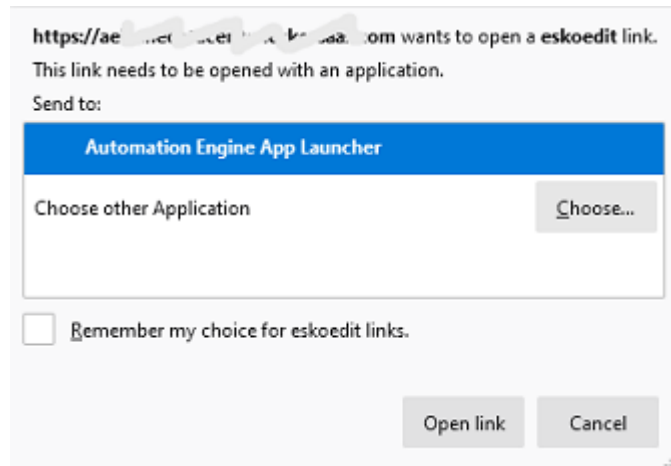

Learn about **eskoedit** and other technical background on the page about [the App Launcher](#).



**Note:** The app on top of the list will be the one taken when you choose 'Open'.

- **Microsoft Edge:**

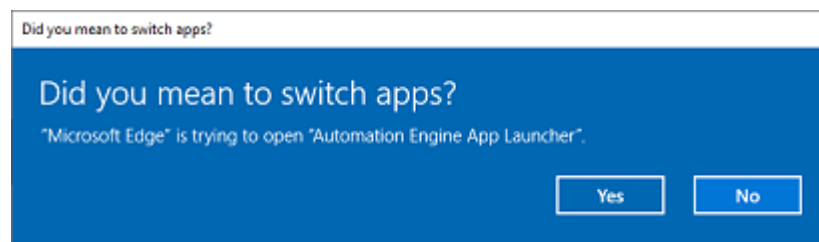

### 12.4.8. Activity page



**Important:** Please first see the related [eLearning Modules](#).

The Activity page shows a list of running and recently ran workflows and DeskPack workflows.



**Attention:** Note that this page only shows workflows, it does not show single tasks.



**Note:** This view only shows workflows that were launched within Jobs or Products with a location attribute that the current user is allowed to see (workflows that ran in Jobs/Products without a location attribute are always shown). Learn more in [Locations](#) on page 220.

Only one entry per workflow is (or DeskPack workflow) is shown ; no workflow steps or individual tasks are shown. Also workflows started by another workflow are not shown.



**Tip:** This page also offers to only show the To-Dos of the current user.



**Tip:** Any [Smart Views](#) that were created in the Pilot will also show up for this similar page in My Workspace (browser client).

### 12.4.9. To Do page



**Important:** Please first see the related [eLearning Modules](#).



**Tip:** This page also offers to only show the To-Dos of the current user.



**Note:** This view only shows to do items that are related to Jobs or Products with a location attribute that the current user is allowed to see (to do items that relate to Jobs/Products without a location attribute are always shown). Learn more in [Locations](#) on page 220.



**Tip:** Any [Smart Views](#) that were created in the Pilot will also show up for this similar page in My Workspace (browser client).

### 12.4.10. User page

- **My Preferences**
  - **Reset all dialog warnings:** Serves to reset your former decision to stop getting requests for confirmation, as in this example when you switch to a job context:

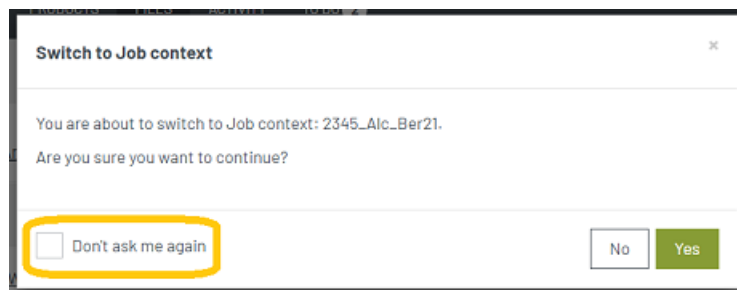

- **My Account.** Info only. Contact your administrator for any changes.
- **Sign out:** For a manual sign out.



**Note:** Your browser session also automatically signs you out when there was no action noticed for a specific time. In this version, this is set to 10 minutes.

### 12.4.11. Notifications slide-out



**Important:** Please first see the related [eLearning Modules](#).

Some extra notes:

- This slide-out shows recent notifications, new ones on top.
- When a new notification is added, all notifications that are older than half a day are removed.
-  **Attention:** Notifications are linked to your current browser session:
  - They only appear in the browser window or browser tab where you did the action that triggered the notification (i.e. launch a workflow). When you open another browser client window/tab, these notifications will not appear in that window/tab.
  - They disappear when you refresh your browser.

## 12.5. Workspace 'Roll-Fed Labels'

---

### 12.5.1. Concept

#### Fast and Easy production of Roll-Fed Labels

This workspace will be available when you also have the licenses for the product that was formerly called "Automation Engine QuickStart for Labels".

Its target user is a prepress operator in a site that produces roll-fed labels (analogue or digital).

Most of the configuration and some of the functionality was prepared by an administrator user using the Pilot client.

All standard browsers are supported. Find details on [www.esko.com/systemrequirements](http://www.esko.com/systemrequirements).

You can use the browser client both for an AE on-premises server as for an AE SaaS server. Learn about the difference in [On-Premises or SaaS](#) on page 34.

### 12.5.2. See the eLearning Modules

- All eLearning modules serve as initial training and can be accessed from within the browser client. Find the course on the workspace 'Roll-Fed Labels' on [Esko's Blended Learning platform](#).
- In this chapter, we only add more details, answers FAQs and more.



**Note:** The UI of the browser client is available in several languages. Go to **<user-name> > My Preferences** and select one of the listed languages.

### 12.5.3. Post-Install Configuration

Once the Automation Engine server software is *installed*, the administrator needs to set up some configuration.

Some configuration steps are done when first signing in to the browser client. Others need to happen on the DFE.

### Configuration when First Using the Browser Client

The Automation Engine installer creates a shortcut on the desktop. Start the browser client using this shortcut.

When starting the browser client the first time on a new system, you will be asked to decide some easy configuration steps:

**1. Create an administrator user**



**Note:** You will be able to create other users later, via the normal tool in the **'Admin'** menu.

When done, login with that user and continue:

**2. Configure a data container**

A next page invites you to set the data container.

By default a data container called **'ExampleJobContainer'** is used. This is a shared folder created during the Automation Engine installation and is located on the same disk as where the Automation Engine software was installed.

In case you want to use a different shared folder, select this shared folder from the drop-down list. The default data container can always be changed (via the 'Admin' menu) but already created products and production jobs will not be moved.

**3. A next page asks you to configure presses and their resources. It refers to this documentation. See the next pages.**

## Digital Press Configuration and Migration of Resources

### Connecting a Press driven by an Esko DFE (incl. HP L&P Print Server)



**Attention:** On this page, "Esko DFE" means a DFE made by Esko, including the "L&P Print Server" as it is offered by HP Indigo.

An Esko DFE already used color strategies, Dynamic Marks and step & repeat templates. In this Roll-Fed Labels setup, you need to make sure that these files are now visible and controlled by the Automation Engine server:

**1. Color Strategies**

You need to redirect the color strategies on the Esko DFE to the AE server. You then also need to copy these color strategy files from the DFE to the AE server.

**a. On the Esko DFE, redirect the Color resources to Automation Engine**

- On the Esko DFE, start up the DFE Configuration tool.
- Go to **Start > Programs > > Esko > HP SmartStream Print Server > HP SmartStream Configuration.**



- Go to the **Data** tab.
- At the bottom, you will find '**Resources search path**'. Choose '**Configure**'
- Choose '**On another computer**' and fill in the name of your Automation Engine server.
- Click **OK** (2x).

**b. Copy Color Strategies from a DFE (Esko DFE or Production Pro) to Automation Engine.**

To copy Color Strategies from a DFE to the AE server, proceed as follows:

**1. STEP 1**

- On the DFE or Production Pro, start **Color Engine Pilot** 13.4 or higher.
- Go to **File > Preferences > Database**.
- **Location of Color Engine Database** : select "**On remote computer**".
- Fill in the name of the **DFE** that you want to copy the color strategies from.
- Click **OK**.
- It might be required to restart the Color Engine Pilot at this point.
- Now go to the list of Color Strategies (**Library > Color Strategies**).
- Select the Color Strategies you would like to copy.
- Once all the Strategies are selected, right-click "**Export**".
- Make sure the button "**archive as one file**" is switched on.
- Use the "**Browse**" button and choose a directory to export the .FP file to.
- Click "**Export**".

This results in an .FP file (containing all your Color Strategies) on the selected location.

**2. STEP 2**

Now import the Color Strategies on the Automation Engine:

- Open the **Color Engine Pilot** (on the Esko DFE or the HP Production Pro)
- Go to **File > Preferences > Database**.
- **Location of Color Engine Database**: Select "**On remote computer**".
- Fill in the name of the Automation Engine server that you want to copy the color strategies to.
- Click **OK**.
- Go to **File > Import** and select the .FP file you created in step 1.

- Click on **“Open”**. All the exported color strategies are now listed in the **“Import”** Window.
- Click **“Import all”** to import the color strategies.

The selected Color Strategies are now available on both the DFE and Automation Engine and the Color Strategy **Check** can be used on these strategies. Learn about this check in the [eLearning course on the workspace “Roll Fed Labels”](#) in the module *‘Color Strategy’*.

## 2. Dynamic marks

Any dynamic mark sets present on the DFE must also be made available to the AE server.

Copy the dmK file in the bg\_data\_marks share on the DFE onto the same share on the AE server (\\<dfeserver>\bg\_data\_marks\_v010\DynamicMarks to \\<aeserver>\bg\_data\_marks\_v010\DynamicMarks).



**Note:** These mark sets can contain DFE variables. Learn which of those are supported in [‘Can I still use my Dynamic Mark Sets that use Esko DFE variables?’](#) on page 908’.

## 3. SRT templates

SRT templates used by the DFE reside on the share \\<dfeserver>\bg\_data\_custom\_v010\powerlayout\DFE.

These SRT files have to be imported into the die database of the AE server. This is done by using the tool in the browser menu **Admin > Dies** (one by one).



**Note:** In case you have a large number of SRT templates, bulk import of SRT files can be done using the Pilot interface: copy the SRT files to the ExampleJobContainer of the AE server and then launch the task **“Import Die”** on these files. When you don’t know the Pilot interface, ask Esko support for help.

## 4. Add the DFE press to the AE configuration

In the browser client, add presses via **Admin > Presses**. Learn more in the [eLearning course on the workspace “Roll fed labels”](#) in the module on *‘Presses’*.

## Connecting a Press driven by an HP Production Pro

### 1. Configuration of Color Strategies

The HP Production Pro should be configured to use the color resources from the AE server. This requires an intervention of an HP service engineer.

In case you already created color strategies on the Production Pro, use the same procedure [as described above](#) to copy strategies from the Production Pro to the AE server.

### 2. Add the HP Production Pro press to the AE configuration

In the browser client, add presses via **Admin > Presses**. Learn more in the [eLearning course on the workspace “Roll fed labels”](#) in the module on *‘Presses’*.

## Known Limitations

- **In Dynamic Marks, DFE specific fields are not supported**

When using DMK sets or SRT templates which contain dynamic marks, the DFE specific text-fields are not supported in this workspace.

- **Non printing inks**

When you add non-printing inks to the configuration of this workspace (**Admin > System > Non-Printing Inks**), you then also need to add these ink names to the list of technical inks on the DFE (both when Esko DFE and when HP Production Pro). This is especially necessary when you work with VDP jobs (both when pre-expanded or template based VDP jobs).

## 12.5.4. Details of the Product's Preparation workflow

This page adds some details to the information mentioned in the module **'Product Preparation Workflow'** as part of the [eLearning course on the workspace "Roll fed labels"](#).

### Preparation Workflow for Digital Printing

#### Preflight to Check EPM

This PitStop preflight uses the profile 'HP EPM Basic Check.ppp'.

The product file will not be considered 'EPM ready' when the check finds any of these items:

- Text inside the trim box with a point size of 6 pt or lower.
- Lines inside the trim box with a stroke width of less than 1 pt.
- Filled objects inside the trim box that are smaller than 1 pt.
- Areas inside the media box with a total area coverage (TAC) of CMYK colors equal or higher than 280%.
- black gradients or black images.
- rich black objects (fill or stroke with 100% K and C between 20% and 60%, M between 0% and 60%, Y between 0% and 60%).

If the input file is a multi-page file (a pre-expanded VDP file), then only the first page is checked.

#### Preflight to Check Objects

This PitStop preflight uses the profile 'AEQS4L\_Basic\_Profile.ppp'. This profile is based on the [GWG profiles](#).

This is what this check does:

- It logs as an **error**:
  - When it finds an empty crop box (GWG 2012 4.04).
  - When blending color space is defined and is different from 'Device CMYK' (GWG 2012 4.26).
  - When the color space of luminosity soft mask blending is different from 'Device CMYK' or 'Device Gray' (GWG 2012 4.26).

- When it finds an image (grayscale or color) with a resolution less or equal than 199 ppi (GWG 2012 4.27).
- When it finds a 1-bit image with a resolution less or equal to 549 ppi.
- When the document is damaged.
- When the document uses any security.
- When the document is empty.
- When there is text inside the trim box that uses any fonts that are not embedded.
- When the document contains annotations of the type 'Movie, sound and 3D', 'TrapNet', 'File Attachment', 'Screen' or 'Watermark'.
- It logs as a **warning**:
  - When checking page rotation flags (GWG 2012 4.05) and it finds a rotation different from 0 degrees.
  - When it finds text objects inside the trim box that use the font 'Courier' (GWG 2012 4.15).
  - When it finds an image (grayscale or color) with a resolution less or equal than 239 ppi (GWG 2012 4.27).
  - When it finds a 1-bit image with a resolution less or equal than 799 ppi (GWG 2012 4.28).
  - When the document contains any annotations of the type 'Text note', 'Markup' or 'Hyperlinks'.

The preflight report is saved in the product's 'Data Zone', in a subfolder 'Reports'. Learn more about these folders in [Where is Data Stored?](#) on page 910.



**Note:** The system keeps only 1 preflight report. When the prepare workflow is started multiple times, this report is overwritten each time.

### A To-Do to Check the Preflight Report (if needed)

How the workflow continues depends on the result of the preflight:

- No warnings or errors: The workflow sets the product status to **Preflight OK** and continues the workflow (if requested, by making the proof).
- Warnings and/or errors: The workflow sets the product status to **Preflight Not OK** and starts the step **Wait for Action (Checkpoint)**, which shows up in the browser client as a **To Do** item.

The user opens the To Do item and reads if the preflight resulted in warnings or errors. He checks the report and then chooses to click on:

- **Preflight OK.** The workflow continues. The users decides that this product file is good enough to produce.
- **Preflight NOT OK.** The workflow stops here. The user decides that this product file needs to be changed, that a new PDF is needed.

### Proof Report

Learn more about this proof in the page [Customizing the Proof Report \(used in the ReportMaker \(Classic\) task\)](#) on page 905.

### A To-Do to Check the Proof (if needed)

After the workflow created the proof file (using the step 'ReportMaker'), it (again) starts a **Wait for Action (Checkpoint)** step, which shows up in the browser client as a **To-Do** item.

- The user can there check the proof file and then choose to click on:
  - **Proof OK**. The workflow continues. The products status is set to **Proof OK**. This means that the proof PDF can now be sent to the customer to get their approval.
  - **Proof NOT OK**. The products status is set to **Proof Not OK** and the workflow stops.

## Preparation Workflow for Flexo Printing

This preparation for flexo does not check for EPM. It does include a step to execute trapping.



**Note:** The main workflow principles are described in the page [Preparation Workflow for Digital Printing](#) on page 901. We here mainly illustrate the profiles that are used in the preflight steps.



**Note:** When the public parameter 'Preflight' is set to 'YES', both the preflight steps are done. Else, none of them is done.

### Preflight to check the PDF file's integrity

The end status will be

- **Preflight OK** when there are no preflight errors (no messages or just warnings)
- **Preflight Error** when there are preflight errors.

The preflight report is named [file]\_PreflightReport.pdf

This PitStop preflight is done using the profile: 'MISINTEGRATION\_CheckIncomingPDFIntegrity.ppp' (same profile as used in the standard MIS integrations).

- This profile logs as an error:
  - if the document contains embedded PostScript fragments (error)
  - if the document contains pre-separated pages (error)
  - if a page is empty (error)
  - if there is more than 1 page (error)
  - if fonts are not embedded (error)
  - if OPI images are used (error)
  - if the document contains JavaScript, actions or form fields (error)
  - for an empty crop box (GWG 2012 4.04)(error)
  - if blending color space is defined and is different from 'Device CMYK' (GWG 2012 4.26)(error)
  - if luminosity soft mask blending color space is different from 'Device CMYK' or 'Device Gray' (GWG 2012 4.26)(error)
- This profile logs as a warning:
  - if a page scaling factor is set (warning)
  - for page rotation flags (GWG 2012 4.05), if rotation is different from 0 degrees (warning)

### Preflight to check the printability (Flexo)

The end status will be

- **Prepress Preflight OK** when there are no preflight errors (no messages or just warnings)
- **Prepress Preflight Error** when there are preflight errors.

The preflight report is named [file]\_PrintingPreflightReport.pdf

This PitStop preflight is done using the profile: 'MISINTEGRATION\_CheckFlexoRequirements.ppp' (same profile as used in the standard MIS integrations).

- This profile logs as an error:
  - when a page is empty (error)
  - when there is more than 1 page (error)
  - when there are more than the maximum number of separations (public parameter)(error)
  - when it finds an empty crop box (GWG 2012 4.04)(error)
  - when it finds overprint white text (GWG 2012 4.09)(error)
  - when it finds overprint white paths (GWG 2012 4.10)(error)
  - when it finds ambiguous spot colors (GWG 2012 4.21)(error)
  - when ICC profile versions is higher than 2 (GWG 2012 4.24)(error)
  - when classic delivery method (no (calibrated) RGB, ICC, LAB, calibrate gray based colors (GWG 2012 4.25) otherwise logged as error
  - when blending color space is defined and is different from 'Device CMYK' (GWG 2012 4.26)(error)
  - when luminosity soft mask blending color space is different from 'Device CMYK' or 'Device Gray' (GWG 2012 4.26)(error)
  - when it detects an image (grayscale and color) resolution less or equal than 199 ppi (error). If resolution is less or equal than 239 ppi (GWG 2012 4.27)(warning)
  - when it detects that the resolution of 1bit images is less or equal to 549 ppi (error). If resolution is less or equal than 799 ppi (GWG 2012 4.28)(warning)
  - when it detects single image page images with a resolution less then 450 ppi (error). If resolution is less than 1200 ppi (GWG 2013 4.29)(warning)
- This profile logs as a warning:
  - when it detects page rotation flags (GWG 2012 4.05) with a rotation is different from 0 degrees (warning)
  - when it detects grayscale objects in overprint (GWG 2012 4.08)(warning)
  - when it detects overprint 100% black text (GWG 2012 4.11)(warning)
  - when it detects ink coverage inside the trim box that is higher than 320% (ignoring objects smaller than 15mm)(warning)
  - when it detects overprint 100% black text defined in deviceGray (GWG 2012 4.12)(warning)
  - when it detects overprint thin (stroke width < 2 pt) black lines (GWG 2012 4.13)(warning)
  - when it detects overprint thin (stroke width < 2pt) black lines defined in deviceGray (GWG 2102 4.14)(warning)
  - when it detects text objects inside the trim box which use the font 'Courier' (GWG 2012 4.15), if such text objects are found (warning)
  - when it detects rich black text (K 85%, TAC 280%) is used (GWG 2012 4.16)(warning)
  - when it detects small text (< 5 pt for 1 colorant, < 14 pt for multiple colorants)(GWG 2012 4.17) (warning)
  - when it detects effective line width (< 0.3 pt for 1 colorant, < 1.5 pt for multiple colorants)(GWG 2012 4.18)(warning)
  - checks the spot color naming (GWG 2012 4.20)(warning)

- when it detects alternate layer configurations (optional content)(GWG 2012 4.30)(warning).

## 12.5.5. Customization

### Customizing the Proof Report (used in the ReportMaker (Classic) task)

The product preparation workflow allows to generate a proofing PDF file. Such a proof file consists of a preview of the product with some technical information. It also contains a second page showing the separations.



**Note:** The language used in this template is the one you have selected as option in the tab **Prepare** of that product.

You can change how that proof file looks by replacing some parts of the proof template file. That template file is installed during the installation of Automation Engine.

#### How to change the Proof template

The PDF files for proofing are using a proofing template supplied by Esko (technically: ReportMaker template). This template PDF refers to 3 separate PDF files that fill different areas of this template.

These external PDF files reside on the folder

```
\\<Name-of-AE-Server>\ExampleJobContainer\Digital Label Production\Resources\ReportMaker
\Parts
```

These PDF files correspond to the areas numbered 1, 2 and 3 in the picture below:

<b>Date</b>	25-Apr-18	<b>Customer</b>	Happy Fruits bvba
<b>Product</b>	20170505	<b>Contact</b>	Michael Jackson
<b>ProductID</b>	20170505	<b>Customer Reference</b>	Lemon juice label 2018
<b>Order Material</b>	Self-adhesive white	<b>Dimensions</b>	73.00 x 70.00 mm

**Winding**





Scale: 100.0 %

**3**

**Inks**

- Black
- 122
- Cutting

**Important:** We advise that this artwork is checked carefully for layout, spelling and text. Please check thoroughly. It is the responsibility of the client to check these points and accept fully liability. Do not sign approval if there are changes to be made, another proof will be supplied.

**Important:** This is a PDF Proof, the colours are not accurate. When PANTONE COLORS are used, the colours must be matched with the official PANTONE guide.

**2**

**Name**

**Date**

**Signature**

**APPROVED**

Simply replace each of these separate PDF files with your own content.

- Area 1 consists of 'Header . pdf'. You could put your own company's logo here for example.
- Area 2 consists of 'Disclaimer . pdf'. Your company probably has its own specific text that you want your customers to sign off on.
- Area 3 consists of the PDF file representing the selected roll winding. There are 8 different windings, represented by 8 PDF files ('winding\_1 . pdf' to 'winding\_8 . pdf'). You or your customer might be used to a different style of these icons.



**Attention:** When replacing any of these 3 Esko supplied PDF files by your own version, make sure you respect the dimensions of the original PDF file. Otherwise they will no longer nicely fit in the default template.

### About the default proof template

This template resides on the folder

```
\\<name-of-AE-server>\ExampleJobContainer\Digital Label Production\Resources\ReportMaker\
```

This template should **not** be changed as it gets replaced by the default template that comes with an Automation Engine installation after each update.

If a different template is required, skilled users or Esko staff can create one using Esko PackEdge but it should be given a different name. They will also need to use the Automation Engine Pilot to create a customized version of the 'prepare' workflow, so that it refers to that new template.



### Units and Language

The unit used in the dimensions (artwork info & dimension lines) and the language of the report are those as set in **the Product's Settings > Tab 'Prepare' > Proof**.

The proof template has all the language specific texts present in dedicated layers (1 per language). The chosen language decides which layer is kept (during the workflow step "**Optimize PDF document**").

### Customizing Workflows

#### Customizing a Product's Preparation Workflow

In the 'Prepare' tab you can save variants of the workflows that are offered by default.

When you want to customise a workflow further than that, this then needs to be done by Esko staff, as a paid service.

For any such request, please contact [Esko Solution Services](#).

#### Customizing a Production Job's Output Workflow

The production job types that have no live connection to a digital press, end in sending files to another component.

In their tab 'Output' you select the matching 'output' workflow, which is by default a simple copy of those files. And you there also specify their destination.

When you want to customise that output workflow, for example to have those PDF files also RIP'ed and submitted to a DFS of an Esko CDI, then this also needs to be done by Esko staff, as a paid service.

For any such request, please contact [Esko Solution Services](#).



**Note:** You may have purchased those services already together with the set up of this Roll-Fed Labels solution. Then this customisation may be done soon after the initial installation.



**Note:** Output workflows that you created using the Pilot client, need a special tag to make them appear in this workspace:

- For the type 'Digital to PDF', the tag needs to contain `QuickStart Digital Output`.
- For the type 'Flexo to PDF', the tag needs to contain `QuickStart Flexo Output`.

## 12.5.6. Frequently Asked Questions

### Which File Formats can I use for a Product?

You can create a Product (part) from these file formats:

- \*.PDF
- \*.AI Adobe Illustrator when PDF compatible



**Attention:** When you use the Esko plug-in '**Borders**' to set the PDF Trim Box / Media Box in Adobe Illustrator, Automation Engine will ignore these settings. To make sure that these Trim Boxes / Media Boxes will be used, you need to export the file to 'Normalized PDF'.

- Esko Normalized PDF when self-contained (no external images or other files).

## What about Multi-page Files?

### Can I use Multi-page Files?

When you use a multi-page PDF to make a product, the system automatically assumes that this file is for a VDP workflow and so decides that this product is a VDP product. A pop-up message informs you about this.

This means that, apart from that VDP case, you can not use multi-page PDFs to make products.



**Note:** In the Viewer, you can compare different pages of a multi-page file. Learn about comparing in this Viewer tool by checking the [WebCenter Online Help \(Complete Manual > WebCenter Viewers > HTML5 Viewer > Compare Documents\)](#).

### Can I Print a Product that is 'Not Ready For Production'?

Yes you can.

As explained in the eLearning module about Product Status, a product will be 'Ready for Production' when it has its file been 'Approved'.

This product status is only information. You can still produce it. But when starting a production job that includes this product, you will be asked if you are sure if you want to print it.

### Can I still use my Dynamic Mark Sets that use Esko DFE variables?

#### Summary

A dynamic mark set can contain dynamic text marks that refer to variables on the Esko DFE.

When launched from this workspace 'Roll-Fed Labels', where they added to the S&R task in the production workflow, most of the DFE variables (press name, printing inks, color strategy...) are supported, with the exception of these:

- '**Screen name**' is not supported. AE has no access to screening info.
- '**Substrate name, Printing Ink Names (long and short) and Color Strategy Name**' are only supported in case the Press Material or Color Strategy are explicitly selected in the UI of this workspace (not when only chosen as 'from Press Ticket').
- '**Step and repeat template name**' is only supported with template dies, in which case it will represent the name of the SRT file it was based on.

#### Table of DFE variables supported in a Dynamic Mark set selected in the workspace 'Roll-Fed Labels'

Category	Field	Info
Document	File name	Comma separated list of the URLs of the input graphics. URLs can contain hex-encoded (%XY) characters.
	File date	Modification date of the input graphic(s).
	File time	Modification time of the input graphic(s).
	File date and time	Modification date & time of the input graphic(s).
	File Trim Box	Trim Box of the input graphic(s).
	File Media Box	Media Box of the input graphic(s).
Color	Input ink names	List of ink definitions of the input graphics.
	Input ink names (short)	List of ink short definitions of the input graphics.
	Printing ink names	List of names of the printing inks (ink set + extra output inks). Only works if color strategy was selected in the workspace 'Roll-Fed Labels' (not from the press ticket).
	Printing ink names (short)	List of names of the printing inks. Only works if color strategy was selected in the workspace 'Roll-Fed Labels' (not from the press ticket).
	Color strategy name	Only works if the color strategy was selected in the workspace 'Roll-Fed Labels' (not from the press ticket).
	Print Job	Print job name
Print job date		Generated by the S&R task (current date/time).
Print job time		Generated by the S&R task (current date/time).
Print job date and time		Generated by the S&R task (current date/time).
Press name		Name of the selected press.
Substrate name		Only works if the press medium was selected in workspace 'Roll-Fed Labels' (not from the press ticket).
Job comment		Typically a message for the press operator.
SRT template name		The name of the SRT template or the name of the numeric die. The S&R task already has this parameter in its ticket.

## VDP Block Distribution = Fill over Rolls

### In an Esko DFE, I can use 'Block Distribution'. Where can I do that in this workspace?

Users of an Esko DFE, when working with VDP jobs, can use a method of distributing the variations called 'Block Distribution'.

Here, in the workspace 'Roll-Fed labels', this function is named '**Fill over Rolls**'.

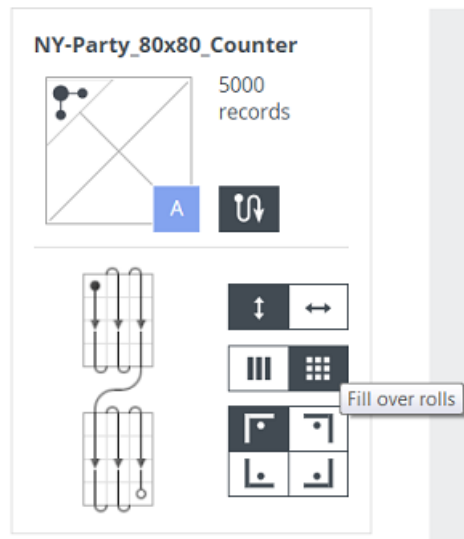

**Note:** In this workspace 'Roll-Fed Labels', the term 'blocks' is used for other (non-digital) use cases.

Learn more in one of the [eLearning modules](#) on **Variable Data Printing**.

In the eLearning module '[VDP - VDT file and Counter](#)', rolls are defined in the tab '**Production Settings**' and distribution of the variants (flow and fill) is defined in the tab '**Printing Sequence**'.

Of course, this function is valid for all 3 types of VDP Products.

### Can I Change the Proof Template?

Yes, you can.

This is described in the page [Customizing the Proof Report \(used in the ReportMaker \(Classic\) task\)](#) on page 905.

### Where is Data Stored?

This workspace offers all the tools to access and view the relevant production data. The extra information on this page is therefore for users that need a more advanced knowledge of where this product and job data is stored. These are typically Esko staff or users who were already familiar with the 'Pilot' client interface.

#### Where is the Data of a Product stored?

- The files that you upload to create a product are stored on the Automation Engine server, decided by a rule-based logic called the **Smart Product Location**.



**Note:** For those that know the 'Pilot' client, this setup can be found at **Pilot > Configure > Products > Smart Product Location**.

- When no rules were configured in that tool, the product files are stored in the 'ExampleJobContainer'. This is a shared folder on the Automation Engine server that was created automatically when Automation Engine was installed.

Product files are then stored according this file path:

```
\ExampleJobContainer\Products\\

```

This folder structure is created automatically when you upload a PDF file for that product (for the first time).



**Note:** If, for some reason, the folder 'ExampleJobContainer' does not exist, the files will be stored in a randomly chosen shared folder (= 'Container'), following that same file path:

```
\<OtherSharedFolder>\Products\\

```



**Note:** New products that were saved but for which no file was uploaded yet will not show a product folder.

- This folder <ProductName> contains the PDF that you upload for this product. When you upload other file(s) later on, they are also put there. Files with a same name will be overwritten.

Subfolders are created automatically for each type of data:

- **\Proofs:** The proof PDF file is located here. When a preparation workflow is run more than once, proof files will be overwritten.
- **\Reports:** The Preflight report PDF is located here. When a preparation workflow is run more than once, preflight report files will also be overwritten.
- **\Uploads:** Product files for which a preparation workflow was started are copied here. To make sure they are not overwritten, a prefix is added to their name with the date and time you started the workflow.



**Note:** The files in these 3 subfolders are visualized in the tab 'Data' of a product's settings. The data **categories** match these folder names.



**Note:** This product folder and its subfolders are also referred to as the **Product Data Zone**.



**Attention:** When you use the browser workspace to remove a product, users of the Pilot client will notice that its complete Product Data Zone is deleted! A clear warning does appear and asks you to confirm before this data is deleted from the Container.

### Where is the Data of a Production Job stored?

The data related to a production job is stored according the same logic as described above for products.

The moment a job is saved for the first time, a folder is created under

```
\ExampleJobContainer\Jobs\

```

(unless otherwise configured in the tool 'Smart Job Location').

Users of the Pilot client can see this folder as a blue 'Job'. The production workflow runs in this job context.

All data created during the production workflow is stored in this folder, in a subfolder `\temp`. Such 'temp' folders are hidden in the Pilot client, but they will be visualized when for example, on one of the tasks in the workflow, you ask to '**Go to Output File**'.

This folder contains:

- the Step & Repeat PDFs. One for each form of layout (`<jobname>_sr_1.pdf` etc..)
- the JDF file to communicate with the DFE (`printrun_***.jdf`)
- XML files describing the product PDFs (location, technical inks to ignore)
- PDF of each station (product PDF or empty station version of that product).

When you use the browser workspace to remove a production job, users of the Pilot client will see that the job is removed from the list of active jobs but that all its data are still kept (the blue folder becomes yellow but all its data on disk remains).

### Where are the Dies stored?

In this workspace, you can create a new die by importing a template step & repeat file (.SRT or .PDF). Learn more in eLearning module '[Dies](#)' as part of the [course on Roll fed Labels](#).

The system reads this file, adds the resulting die to its database and uploads the imported file to the AE server on:

```
\Esko\BG_DATA_CUSTOM_V010\powerlayout\ae
```

### Can I Remove an Order Material that is in Use in a Job?

When you remove an order material, products that used that order material will from then on have this setting on **<none>**.

The same thing happens for production jobs: this setting (which it gets from its products) also changes to **<none>**. This is not a real problem as you can still start its production workflow.



**Note:** Mind that the material that needs to be communicated to the DFE is not the order material but the press material. The order material is currently only used as a filter when adding products to a job.

Follow these steps to get a different order material in a production job:

1. Update the products of that production job with another order material.
2. In the production job:
  - a. first remove those product(s),
  - b. then (re-)add the updated product(s) (and re-set the quantity and printing sequence).

### What happens when I make Changes to a Product that is Used in a Production Job?

#### Can I change attributes of a Product that is used a Production Job?

Yes you can. However, the moment a product is added to a production job, its settings like customer ID and order material are *copied* into that job. These values are not just references.



**Important:** This means that changing the order material and/or customer of a product *after* the product has been added to a production job does *not update* the value of the order material and/or the customer of a production job.

**What happens if I Rename a Product After it was already Added to a Production Job?**

Renaming a product while it was added to one or more production jobs is not a problem. The jobs can be produced successfully. The job uses an internal ID reference to its products. It will pick the products it was intended to use.



**Attention:** When a print mark is asked to put the product name on the layout PDF, this could be the old product's name (depending on the time the changes are made).

## 12.6. ADMIN page

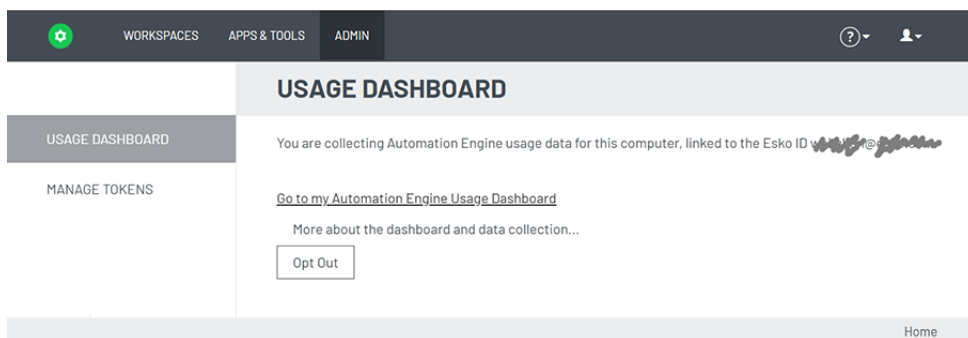

This page serves to

- define if you want to have a **usage dashboard**.
- **manage tokens** for external systems that wish to communicate with AE via HTTPS (AE SaaS only).

Learn more in the chapter [Automation Engine Server Management](#) on page 1997 , in the section [The AE Browser Client ADMIN page](#) on page 2039.

## 13. ArtPro automation - ArtPro Action Lists

---

### 13.1. Automating ArtPro Processing

---

Automation Engine can automate the processing of ArtPro native files. This can be a single action or a list of actions. Such lists of actions could formerly have been run as (parts of) Nexus workflows.

All this processing is initiated by one task, the [Apply ArtPro Action List \(Classic\) task](#). This task takes native ArtPro files as input, processes them and can then output either ArtPro files or convert them to a range of vector formats. Several actions can also process other file formats or even gravure TIFFs.



**Note:** This workflow is in some documents referred to as "ArtPro Processor on Automation Engine".

The task runs an **ArtPro Action List** that defines the chain of actions to be executed. Such "Action Lists" can be created and edited by using the [ArtPro Action List Editor](#).

#### About Converting Nexus Workflows into Automation Engine Workflows:

In Nexus Manager, you can select a part of a Nexus workflow and choose '**Save as Action list**'. However, you still may have to adapt settings to get an identical result (fonts, marks, etc.).

Especially when you have complicated Nexus Processor workflows with file dependencies and "Select File" activities, your similar Automation Engine workflow will probably be a combination of small action lists and Automation Engine workflow controls like Router, Select File, etc.

### 13.2. The ArtPro Action List Editor

---

The **ArtPro Action List Editor** allows you to create and manage ArtPro **Action Lists** (\*.aal files) that you can then launch with the [Apply ArtPro Action List \(Classic\)](#) task.

#### 13.2.1. Installing the ArtPro Action List Editor

This tool is one of the client tools that you can download from the **Automation Engine Server Web Page**.

- Open the **Server Web Page** by entering `http://<name of your server>` or `http://<name of your server>:9999` in the address field of your browser.
- Find this tool in the section **Client Apps**, in the page **Tools**. Click **Download** to install it on your client computer (Mac or Windows). Run the .exe or dmg to install the application.
- When opening the installer editor for the first time, the **Edit Preferences** dialog asks you to enter the name of your Automation Engine server and a valid user name and password.



### 13.2.2. Working with ArtPro Action Lists

There are 2 ways to open the **ArtPro Action List Editor**:

- Start it from the desktop shortcut or application icon on your client computer. Then use the menu options.
- Or select an Action List in the **Apply ArtPro Action List task** and click the **Edit...** button to open it directly in the editor.



When you open an **Action List**, the dialog contains 3 main parts:

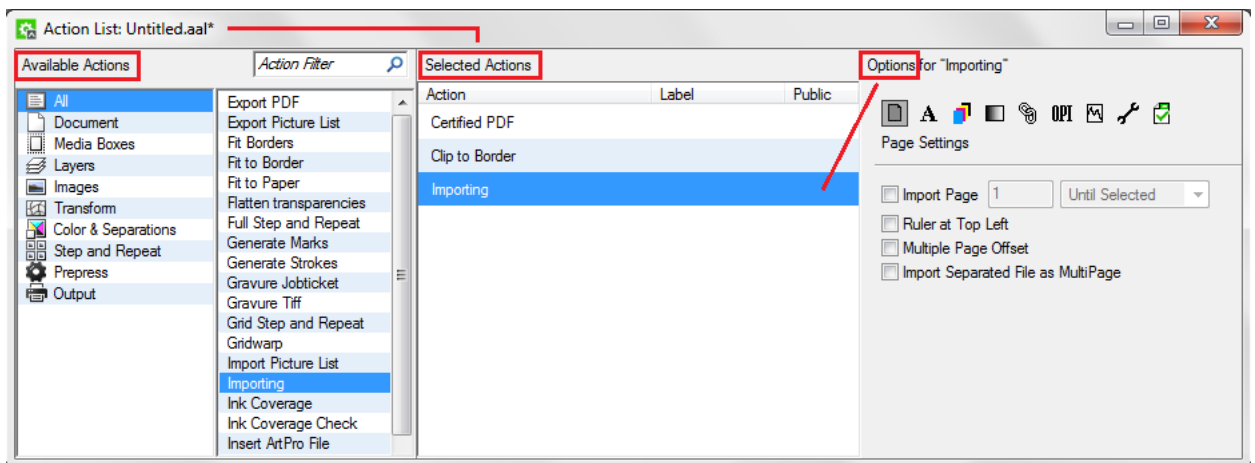

- (Left) The library of **Available Actions**: This section shows two columns. The left one offers to filter by category. The next column shows the full or filtered list. You can drag and drop actions from this column to the **Selected Actions** section.
- (Middle) **Selected Actions**. This shows the actions in this (opened) action list (of which the name is shown in the title bar). You can double click in the column **Label** to add a label that helps to identify these unique actions, for example when using public parameters.
- (Right) **Options for the selected action**. This displays the all settings for the selected action. Edit them as wished. When you close the window, you will be asked to save the changes you made.

#### Action List Menu Options

Here is a quick overview of the menu options in the **ArtPro Action List Editor**:

1. In the **File** menu:

- **New / Open / Save Action List...**
- **Import NeXML File....** Use this to import Nexus workflow tickets.
- **Save Action List As...:** Apart from defining a (new) name, notice that you will be proposed to save the \*.aal file in its default location \\AEServerName\bg\_data\_custom\_v010\dat

\ArtPro Action Lists. This is also the folder that the **Apply ArtPro Action List** task looks in.

**2. Edit** menu:

- **Cut / Copy / Paste / Delete:** Use this option to cut / copy / paste / delete action(s) from the **Selected Actions** section. You can multi-select and use the available shortcuts.
- **Select All.** To select all **Selected Actions** in the current action list.
- **Edit Preferences....** To set your server, units or language preferences.

**3. View** menu: **Hide / Show Library:** To hide or show the library of **Available Actions**.

**4. Window:** Because you can open multiple action lists at the same time, each in their own dialog you can here select the one to be active.

**5. Help** menu: The **About** shows the software version of this tool.

### Creating an Action List

To create an action list:

1. In the **File** menu, choose **New Action List....** A dialog opens for the new **Action List: Untitled.aal\***.
2. Add actions and define their parameters:
  - In the first column of the **Available Actions** section, select **All** to view all the available actions in the second column. Or filter the actions by category or by typing in a filter. .
  - Double click or drag actions from the second column of the **Available Actions** section to the **Selected Actions** section.
  - To remove an action, select it in the **Selected Actions** section and press **Delete**.
  - Select an action in the **Selected Actions** section to view its parameters in the **Options for "selected action"** section. Edit these parameters as wished.
3. Click **Save Action List As** in the **File** menu to save this action list with a proper name.



**Note:** Action lists have to be stored in the folder \\AEServerName \bg\_data\_custom\_v010\dat\ArtPro Action Lists to appear in the task's drop-down list.

## 13.3. Handling Fonts in ArtPro Files



**Important:** All fonts used in ArtPro files that are handled by Automation Engine should either be:

- embedded
- referenced and located in a folder accessible to the Automation Engine server.

When a font is not accessible, you will get an error when trying to add or edit text, update text objects using ArtLink, export the file to PS or PDF, etc.

**ArtPro Files coming from a Nexus on Mac OS**

Type of ArtPro file in Nexus workflows	Consequence on fonts in Automation Engine
ArtPro files created, edited or opened in ArtPro.	<p>These ArtPro files have all fonts and outlines embedded (subset). They can be opened, repeated, output... in any ArtPro action list without any font problems.</p> <p>Exception: ArtPro files containing ArtLink'ed text containing a character that was not embedded (not yet used in the ArtPro file and the font is not available).</p>
ArtPro files created by a Nexus workflow (files that have not been opened and saved by ArtPro).	<p>These files do not contain any font embedding. Therefore, they cannot be used to generate PDF export, unless:</p> <ul style="list-style-type: none"> <li>• You add a <b>Text to Paths</b> action before outputting the file to PDF.</li> <li>• You add all the necessary font folders in your first action (see below). Note: you can also add fonts and images folders in the 'Export PDF' action (in Images &gt; File &amp; Font settings).</li> </ul>
ArtPro files created by a Nexus workflow starting with a PS/PDF import.	<p>Referenced fonts are not available during this workflow!</p> <p>Any action that needs text outlines (Generate Marks, Print to File, Export PDF,...) will error.</p> <p>To avoid this, you need to:</p> <ol style="list-style-type: none"> <li>1. Insert a <b>Save</b> action immediately followed by an <b>Open ArtPro file</b> action.</li> <li>2. In the <b>Open ArtPro file</b> action, define the necessary font folder.</li> </ol>

**Handling the Fonts Correctly in an ArtPro Action List**

In general, opening an ArtPro file does not need the glyphs from the characters in the file, because ArtPro always stores the vectorized representation of the complete text block in the file.

When using ArtPro action lists and importing PDF files with non-embedded fonts, the fonts need to be available on the Automation Engine server. Follow these steps to make them available:

1. Create a fonts folder in an Automation Engine **Container** (a Windows network share made 'Container').
2. Move the fonts from the Mac to that folder (on Windows) using a third party font conversion tool (for example [CrossFont](#)).
3. In your action lists, adapt the parameters of actions that need font resources (for example the **Importing** action).



**Note:** We recommend using TrueType fonts.



**Attention:** When copying any font, make sure that you have the appropriate licenses to install and use this font!

## 13.4. The Apply ArtPro Action List Task (Classic)



This task enables processing single or multiple actions on ArtPro native files.

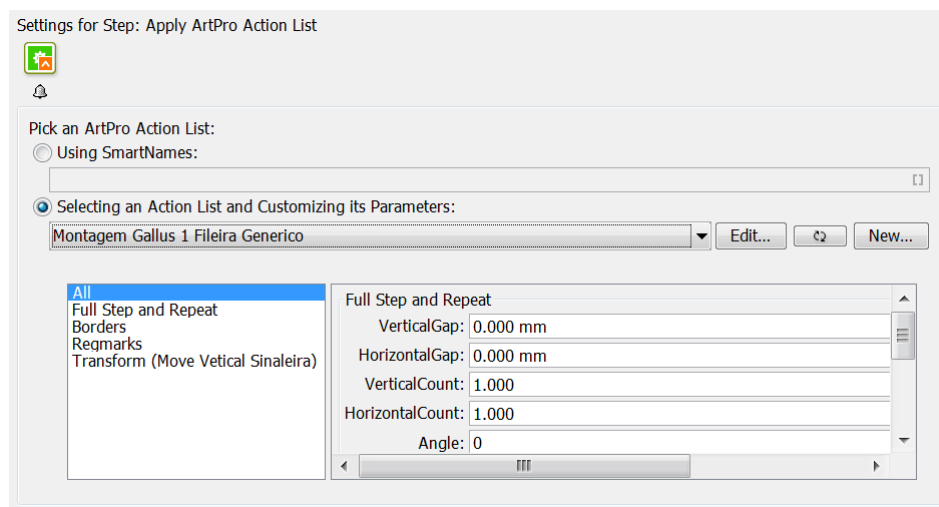

**Note:** Learn more about this concept in the [introduction of this chapter](#).

The task launches an **ArtPro Action List** that you created earlier in the [ArtPro Action List Editor](#).



- You can define the action list by [SmartNames](#) or by **Selecting** it from the drop down list, in which case you can also see and edit the parameters that were made public.
- The **Edit...** button opens the action list in your locally installed [ArtPro Action List Editor](#).
- Click  to refresh the list and update the panel (it does not change any parameter values).  
Click  while holding the **Shift** key to revert the parameter values in the panel to the values that were saved in the action list.
- Click **New...** to type in a name and then open the [ArtPro Action List Editor](#).

Learn about all the available actions in these action lists in [Available Actions](#) on page 919.

### 13.4.1. Using SmartNames in the Apply ArtPro Action List task



**Note:** Learn about SmartNames in the dedicated chapter [SmartNames](#) on page 637.

In an action list value field, you can right-click or click on  to use SmartNames to define the value. There is even a dedicated 'ArtPro' category:

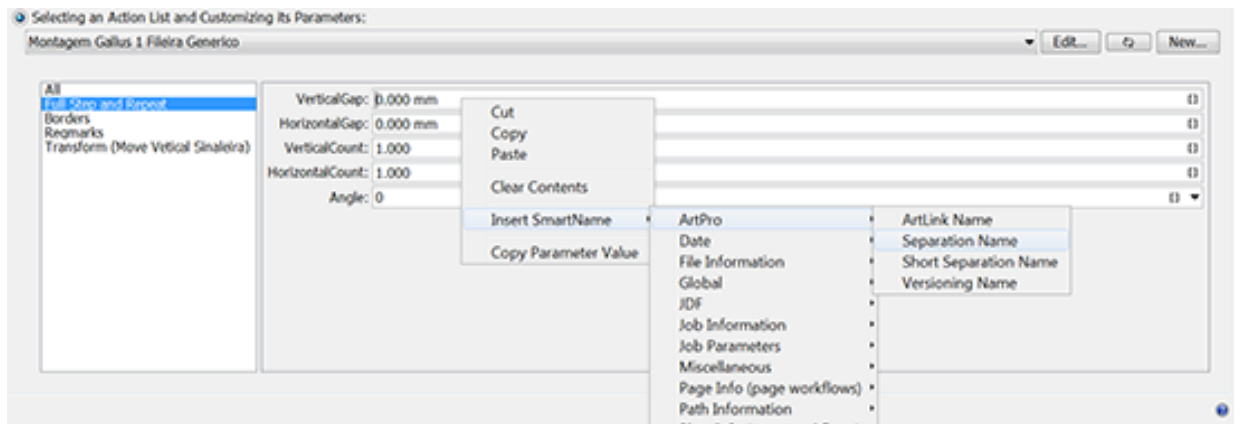

This task has access to Automation Engine SmartNames linking to ArtLink parameters in ArtPro files.



**Note:**

- The SmartNames are resolved when the ArtPro file is opened.
- You can not use SmartNames that require their value from the Automation Engine task itself (for example `TaskID`). You can use SmartNames based on file location or file name.
- You cannot use a *Workflow Parameter* directly as an ArtLink parameter.



**Tip:** You can however make it a public parameter and then use the workflow parameter there.

- When an ArtPro file is saved in a **Job** and linked to a *Job Parameter*, the information is only kept within that Job. When the same file is saved outside that Job, this Job parameter info is lost.
- When a *Global Product* is linked to multiple Jobs and Job SmartNames are used, any of these values can be stored in the file. The ArtPro actions do not update the parameter to the current Job.

## 13.5. Available Actions



**Note:** Many actions are identical or very similar to functionality in ArtPro. In those cases, this documentation only offers a basic explanation and refers to a more detailed description in the [ArtPro user guide](#).

### 13.5.1. Adjust Stroke Width

This action allows to change the width of all (selected) strokes.

You can use this for example to give hairlines a minimal width. To do this, first use the [Select Objects](#) action to select all strokes smaller than the minimum width, then use this **Adjust Stroke Width** action to change their width.

### 13.5.2. Apply Pictures

This action replaces a picture (= an image or a placed ArtPro File) with another picture. You can replace an earlier selected picture or all pictures in the file ("apply on all objects").

This function may be useful to replace the graphics in a step and repeat template with another graphics file.

- **Center Picture on:** For ArtPro and PDF files, choose which box is to be used to center the graphics when applying the picture (file) to the object(s) in the file.
- **Remove Unused Separations:** Removes all empty separations after the **Apply Pictures**.
- **Place Single Separation ArtPro File in Single Separation:** Defines how to insert ArtPro files with only one separation. When this option is not selected, objects in this ArtPro file with 100% of the single separation are considered to be registration color and thus get 100% of every ink in the ArtPro file after insertion. When this option is selected, the file is inserted in one single separation instead.

### 13.5.3. ArtLink

ArtLink enables automatic generation of multiple variants of a template file based on database information (a .txt or .csv file). You can choose to create different variants as different files or add the variation as extra layers.

The template file needs to be made in ArtPro. You there select objects and link them to parameters in the database file or add automatic parameters based on job content. Please see to the [ArtPro user guide \(File menu > Parameters \(ArtLink\)\)](#) for a full description of the ArtLink module.

In the next pages we describe how an action list needs to be set up in order to automatically generate ArtLink versions with the ArtPro Action List Editor.

#### Example of Using ArtLink in an Action List

In our example, an input folder contains an ArtPro template file "ice cream template.ap", a database file "ice cream.txt" and also an "images" folder with the various images that will be used for the versioning (strawberry, lemon, lime, orange, peach and tomato).

The action list should contain a [Select File](#) action and an **ArtLink** action. Be aware that the ArtLink action has an embedded Open and Save action, so there is no need to also add those to the list.

See how the Select File action selects both the .ap and the .txt file:

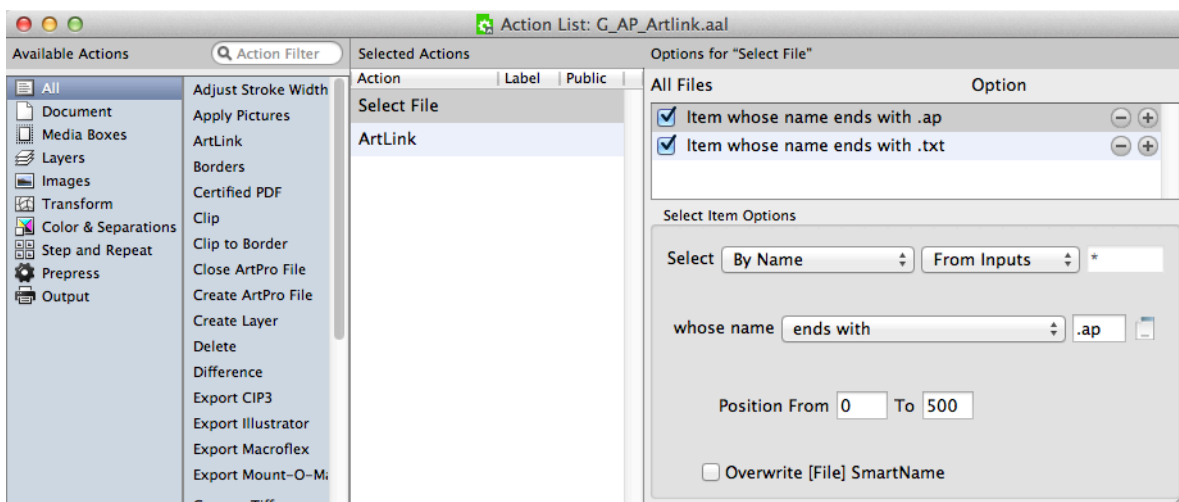

**Note:** When you do need to add an *Open ArtPro file* action (maybe in an *Update ArtLink* workflow), then make sure you *only* selected the .ap file in the preceding action.

### Setting the ArtLink Action

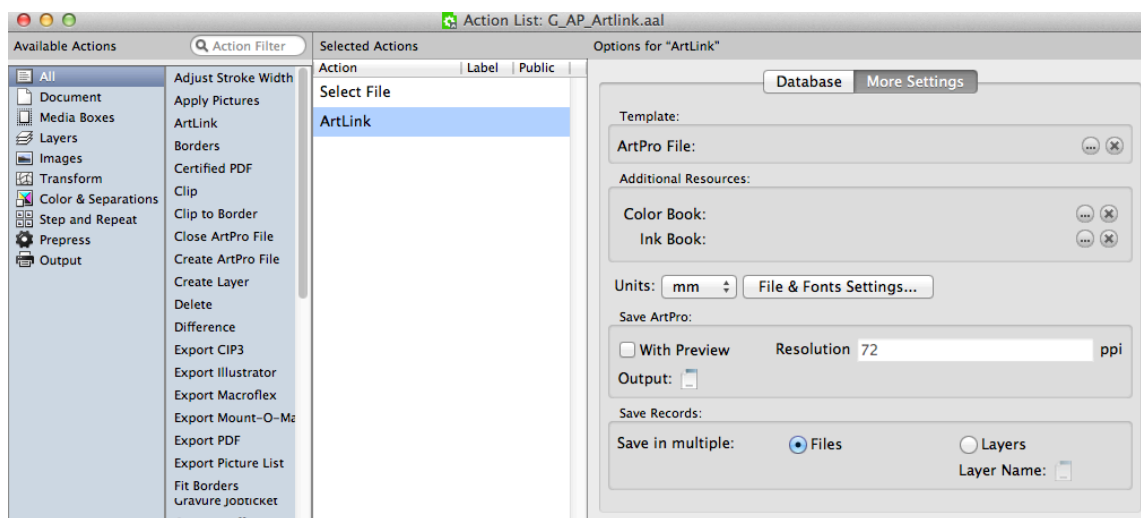

#### (ArtPro) Template

In our example, we here do not need to select the ArtPro template because this was already done by the Select File action. You could however do this when the ArtPro File with the links is a fixed file.

#### Additional Resources

Additional Resources allows to locate the Color and Ink Book that needs to be used, similar as you would load these in ArtPro when colors or inks need to be defined from a library (for example: PANTONE™ library).

### File & Fonts Settings...

Since the ArtPro template file may contain images (on the same or a different server) and fonts, this dialog enables working with root folders, folder mapping and font folders. The fonts are obviously necessary if variable text needs to be generated based on the database file. Learn more about the **File & Fonts Settings...** in the page on the [Open ArtPro File](#) action.

### Save ArtPro

Use the Template Editor in the **Output** button to define the name and place of the files generated by ArtLink.

Our example will generate six files, each with a variable extension: .Alnk\_1 to .Alnk\_6.

Choose if you also want a Preview and at what resolution.

### Save Records

You here define if the results of the different records should be saved as multiple ArtPro files ("**Files**") or as one single ArtPro file containing different Layers ("**Layers**"). In that case, use the Template Editor to define the name of these different layers.

### The Database File

Our example uses a this text file (exported from a database):

```
PANTONE;ice;barcode;pict
"300";"Blue Curacao Ice Cream";"54327719";"::~images:strawberry"
"399";"Margharita Ice Cream";"54327627";"::~images:lemon"
"370";"Caipirinha Ice Cream";"54327719";"::~images:lime"
"orange";"Tequila Sunrise";"54327726";"::~images:orange"
"1645";"Peché Mignon Ice Cream";"54327733";"::~images:peach"
1797;"Bloody Mary Ice Cream";"54327740";"::~images:tomato"
```

The first line describes what variables will be used. Each below line describes the values of these variables for one output file:

- `PANTONE`: the color entry in the color book to be used
- `ice`: a text string
- `barcode`: the value of a barcode to be used
- `pict`: an image to be used



**Note:** The images are described as `~images:xxx`. `~` describes the current position of the template file and `images` is a subfolder located relative to the current position of the template file. Images will also be searched through the Files & Folders settings, so the full exact path is not always necessary.

### The Results

After processing, our example will have generated six ArtPro files. They will vary in color, text string, barcode and the image.

The **Template Editor** allows the use of parameter values from the database records. The value of the SmartName [`n-th Input file`] can for example be used as a template key for the **Save ArtPro** file template.



### 13.5.4. Borders

The **Borders** action allows to modify the size of the current file. You can choose which page box you want to modify.



**Note:** When you want to modify multiple page boxes, you need to set multiple 'Borders' actions in the action list.

The square buttons in the window allow to set the direction of the size change versus the current file size.

It is also possible to calculate a difference to the current size of the page box selected in the option "**start from Box**". In this case the **Vertical / Horizontal Size** fields needs to be left to 0, while you enter the changes in the **Extra V/H Size** fields. These values can be positive or negative and serve to make the current box size larger or smaller, again with the direction depending on the selected square button.

For example: a file was imported from PostScript with the bleed of 3 mm contained in the file size. To change the borders to a correct Trim box (usable to start Step & Repeat or Imposition), choose **start from Trim box** and set both **Extra V/H Size** fields to  $-3$  mm.

### 13.5.5. Certified PDF



**Note:** Check whether Automation Engine's (more recent) [PitStop PDF Preflight tasks](#) are a better option for you workflow.

This action allows to integrate the Certified PDF workflow functionality in these action lists. It allows to import Certified PDF, edit and export as Certified PDF with information about edits and changes to the document. Certified can be divided in three parts: Input, Output and Certified ArtPro sessions.

#### Certified ArtPro Sessions

Automation Engine can work in Certified Mode, by selecting **Certified PDF enabled**.

User name, Short User Name, etc. provide the information about the person or application that is editing the PDF document. This information is stored in Certified PDF each time when a new session is started.



**Note:** When **Certified PDF enabled** is selected, the field "User name" is mandatory.

Working in Certified mode affects all following Open/Save actions. Whatever the Certified options are, Automation Engine is now recording the history of changes made to the file and saves them on-board the ArtPro file.

Learn more about versions and sessions in the [ArtPro User Guide \(ArtPro menu > Certified ArtPro\)](#).

### 13.5.6. Clip

This action uses the front-most selected path as a cutting form to adjust the shape of the underlying paths. Any part of the underlying paths that falls outside the front-most one will be cropped. It so masks out the selected paths underneath.

The original paths are modified. For a more detailed description, see the [ArtPro User Guide](#).

### 13.5.7. Clip to Border

This action clips all the objects to the edge of the selected Border (page box).

Objects located completely out of the page box are removed. Objects located partially inside the selected page box are clipped to the page box.

Choose **All** to apply on all objects. Choose **Selections Only** to apply it to the selected objects only.

### 13.5.8. Close ArtPro File

This action closes the currently open ArtPro file and so removes it from the application's memory.



**Attention:** When you end your action list with a **Save ArtPro file**, it is no longer required to also add a **Close ArtPro file** action right after it (as was necessary in Nexus).

There is one case however where this is still required: when your action list re-opens a file that you just saved, you may create this sequence of actions: save - select - open. In such a case, you need to add a close action after the save action: save - close - select - open.

### 13.5.9. Create ArtPro File

This action creates a blank ArtPro file which can be used later to add pictures, insert other files, etc.

### 13.5.10. Create Layer

This action creates a new layer in the current ArtPro file. Further processing takes place in the newly created layer.

A typical example is a double burn workflow, where multiple files are imported (CMYK of first version, K of second version, K or third version, etc.). To make later editing easier, set a **Create Layer** action before each of the imports, so layering the final output file. Define the name of the layer in the Template Editor dialog.

**Move objects to this layer** enables to move the selection to the newly created layer.

In **Position**, choose to create the layer on top or at the bottom of the file's list of layers.

### 13.5.11. Delete

This action allows to delete **objects**, **separations** or **layers** from the current file.

- **Objects**

- **Delete objects.** Choose **All** or **Selection Only** to define what you want to delete. Deleting all objects could be used to delete the contents from a file but keep all its page boxes for another document (or picture) to be imported or placed. Learn more about selections in [Select Objects](#).
- **Delete Links.** Select this to (also) delete links in the file.

- **Separations**

- **Separations mode.** Select **Leave as is** to leave the separations untouched. Select **Remove** to define which separations to remove. Select **Only Include** to define which separations to keep. The **Delete Unused Separation** option is not influenced by this setting.
- **Technical / Varnish / Opaque.** Use these to define if such types of separations should be removed or included.
- **Separations list.** When the **Separations** mode is set to **Remove**, all separations defined in this list are deleted from the file. When the **Separations** mode is set to **Only Include**, only the here defined separations are kept and all others are removed.  
Use + and - to add or remove separations. Separation names can contain wildcards (\*).
- **Delete Unused Separations.** When selected, unused separations are deleted, regardless of the choice in the above Separation drop-down list.

- **Layers**

- **Delete Layers.** When selected, all layers defined in the list are deleted from the file.  
Use + and - to add or remove layers. Layer names can contain wildcards (\*).
- **Delete Unused Layers.** When selected, unused layers are deleted.
- **Delete Non-Printing Layers.** When selected, non-printing layers are deleted.



**Note:** When the settings request to delete all layers, the first layer will still remains and a warning is shown.

### 13.5.12. Difference

This action is used to calculate the differences between two ArtPro files. This function is useful to verify that the graphics of two different language versions fit, to find out what changes a customer made to the new label, to verify that corrections on files have been executed, etc.



**Note:** Learn about more recent tools to compare files in the chapter [Quality Control tools](#) on page 1077.

**File & Font Settings....** Since this action actually opens two ArtPro files, in some cases it may be necessary to specify Root Folders, Folder Mapping and Fonts folders. Learn more in the action [Open ArtPro File](#) on page 942.

Learn more in [ArtPro User Guide \(File menu > Create Differences\)](#).

### 13.5.13. Export CIP3

This action creates a CIP3 file of the current file.

A CIP3 file is used to transfer data about a specific file through the production process. Besides a preview which can be used to extract ink key settings, a CIP3 file contains information about separations, ink coverage, file dimensions, etc.

You can choose the **Oversampling** and the **Resolution** of the preview that will be included in the CIP3 file.

### 13.5.14. Export Illustrator

This action exports the current ArtPro file to an Adobe Illustrator native file (v3, 5 or 7.0).

#### **About Transparencies and Flattening**

Learn about this in the [ArtPro User Guide \(File menu > Export Illustrator\)](#).

#### **Compatibility and Restrictions**

Learn about this in the [ArtPro User Guide \(File menu > Export Illustrator\)](#).

#### **Downsample Images**

You can here choose to sample the images in the file 2, 4 or 8 times or not at all.

### 13.5.15. Export Macroflex

Learn more about this feature in the [ArtPro User Guide \(File menu > Export Macroflex\)](#).

### 13.5.16. Export Mount-O-Matic

Learn more about this feature in the [ArtPro User Guide \(File menu > Export Mount-O-Matic\)](#).

### 13.5.17. Export PDF

This action converts the active ArtPro file to a vector PDF file.

Learn more in the [ArtPro User Guide \(File menu > Export PDF\)](#).

### 13.5.18. Export Picture List

This action exports an ASCII text file with information about the name, position and size of the bounding box, the picture center and page box of placed pictures. You can use a Picture List file in the action [Import Picture List](#).

Choose whether you want to add mapped pictures in this file.

### 13.5.19. Fit Borders

This action adjusts the document size and the selected page boxes to all the objects present in that file.

Note that when **All** is selected, all page boxes will be set to the same size.

### 13.5.20. Fit to Border

This action fits all or the selected objects to the edge of the selected page box.

When **Scale Proportionally** is selected, all objects are scaled proportionally, until the bounding box of the selected object reaches the selected border, either in vertical or in horizontal direction.

When **Scale Proportionally** is not selected, the selection is scaled to fit the borders both vertically and horizontally. This is sometimes used when creating flexo sleeves.

The scale factor can be rounded off using the **Scale round to** value. For example, when set to 5, the scale is rounded down to the closest multiple of 5. When set to 0, no rounding is applied. The up-scaling can be limited using the **Limit scale to** field.

Select **Notes** to also transform notes along with the rest of the file, so that the positioning of the notes inside the file remains the same.

### 13.5.21. Fit to Paper

This action fits the file to the most appropriate paper size from a list of paper (or plate) sizes.

Click **+** to add paper sizes.

In **Box**, define which page box is to be used to determine the optimal paper size.

In **Layout**, define how to position the file versus the selected page box. **Fit To Page** also scales the file to the optimal to fit on the optimal paper size.

**Rotate to fit** allows to rotate the file when searching for the optimal paper size.

### 13.5.22. Fix Thin Parts

Learn about this feature in the [ArtPro User Guide \(chapter 'Prepress menu' - 'Thin parts'\)](#).

### 13.5.23. Flatten Transparencies

This action serves to flatten blend modes and overprints. It can also be found as a section on board the actions 'Export PDF' and 'Print' .

This technology replaces all blend modes by "normal" objects and still maintains the final result. The blend is calculated to whatever is underneath at that time and is adapted in a line-art object (if possible) or an image.

Learn more in the [ArtPro User Guide \(Prepress menu > Flatten transparencies, and also in the ArtPro menu > Preferences > General: Flatten\)](#) .

**Ignore Overprints On Placed Art:** This option allows to ignore overprints on top of placed art. When this option is not selected, overprints on top of placed art (example: a Step & Repeat) results in a failed action.

### 13.5.24. Full Step and Repeat

The Full Step and Repeat action is based on ArtPro's Interactive Step And Repeat. This functionality allows you to create a repetition of one single file at a time, based on either count or fill size.

#### General

Learn more in the [ArtPro User Guide \(Prepress menu > Step and Repeat Interactive\)](#).

**Cut Marks.** When selected, cut marks are automatically generated around the repeat block, based on the used box size. When bleed is applied in between labels, double cut marks automatically appear. The cut marks are filled with registration color.

#### Pattern

This option is used to make nested Step and Repeat: the second row or column is shifted each time and the step distance can be decreased so the labels fit into one another.

Learn more in the [ArtPro User Guide \(Prepress menu > Step and Repeat Interactive\)](#).

#### Advanced

##### Page Box

Choose which page box needs to be used to step and repeat. By default, this is the **Trim Box**.

##### Place Single-Separation ArtPro File in Single Separation

This option defines how to handle repeating ArtPro files with only one separation. When this option is not selected, objects in the ArtPro file with 100% of the single separation are considered to be registration color, and thus get 100% of every ink in the ArtPro file after repetition. When this option is selected, the file is placed in one single separation.

#### File & Font Settings

Provides access to the root folders, folder mapping and fonts folders when the file to be stepped is an ArtPro file. Learn more in [Open ArtPro File](#).

### 13.5.25. Generate Marks

This action adds marks to the file, based on the dimensions of the chosen page box.

Learn more in the [ArtPro User Guide \(Prepress menu > Marks\)](#).

### 13.5.26. Generate Strokes

This action creates strokes around all (selected) objects.

#### Separation Name / Ink book

Strokes generated by this action get 100% coloring of the separation name entered here and overprint for all other separations. When the separation does not exist yet, it is created, in which case the specifications for the ink are searched in the defined Ink book.

#### Apply on All / Selections

Choose whether strokes should be applied on all objects or only on the [selected objects](#).

#### Add Stroke to Crop / Trim / Bleed Box

Allows to add a stroke on the selected page box.

Learn more in the [ArtPro User Guide \(Window Menu > Stroke\)](#).

### 13.5.27. Gravure Job Ticket

This action export files for gravure systems from [Hell Gravure](#).

When the parameters can not be retrieved from the job ticket, you can here define the **Resolution** and **Oversampling** rate. Each job ticket and thus every separation can have a different value.

For separations with a resolution above 600 ppi and without oversampling, you can select **PackBits Compression for HiRes**. Otherwise, you can **Compress the TIFF** using LZW, or leave the separation uncompressed (if you did not select **Compress TIFF**). PackBits compression results in lower compression rate, but will be calculated much faster than LZW compression, so it is the best solution for high resolution files.

When selecting **Separation Count in ArtPro File and Ticket Folder must match**, the gravure job ticket will check if the separation count in the ArtPro file matches with the ticket count in the folder.

When the size of the ArtPro file and the job ticket size don't match, this action can generate a warning or error:

- Select **Error when ArtPro job and job ticket size don't match** to get an error. Also, no file will be generated.

- Deselect **Error when ArtPro job and job ticket size don't match** to get a warning instead and still have a Gravure Job Ticket output file generated.

For more specific information, please contact [Hell Gravure](#).

### 13.5.28. Gravure Tiff

This action outputs ArtPro files directly as TIFF data for gravure printing. It creates one TIFF file per separation.

Learn more in the [ArtPro User Guide \(File menu > Export Gravure TIFF\)](#).

### 13.5.29. Grid Step and Repeat

This action allows to create a repetition of different ArtPro (or other supported) files that have the same size and that are all placed in the same folder.

In the action list, first the one-up files are defined using a [Select File](#) action, after which you use this **Grid Step and Repeat** action.

This repetition can be executed by starting it on a layout file, a comma separated text file that contains the positioning of the different files).

Learn more in the [ArtPro User Guide \(Prepress menu > Step and Repeat Grid\)](#).

### 13.5.30. Gridwarp

This action allows to calculate complex warping of documents based on a source grid and a destination grid. It can handle the warping of all object types including gradations and images. It is typically used to warp the graphics of conic cups, metal containers, etc.

Grid Warp requires two files, an ArtPro file and a grid file. This action is therefore similar to the [ArtLink](#) action where two files are first selected by the [Select File](#) action.

Click  to select a **Grid** file. When no grid file is available, the grid defined in the ArtPro file itself will be used (when available). This allows to set up grid warp in ArtPro, and let Automation Engine do the calculation.

### 13.5.31. Import Picture List

This action enables to import an ASCII text file that contains information on name, position and size of the bounding box of placed pictures.

Learn more in the [ArtPro User Guide \(File menu > Import Picture List\)](#).

### 13.5.32. Importing

This action allows to import PostScript 3 and PDF files into the native ArtPro file format.



When a file is imported, typically all objects are made editable and all paths in the PostScript or PDF document are converted to internal ArtPro paths. Text however will in some cases be converted to outlines (depending on the settings in the **Font Settings** dialog box and depending on 'Creator' of the PS or PDF file).

### About Importing Screening Parameters

- Detecting Esko screens

When importing a PS/ PDF file that contains Esko screens, these screenings are recognized and automatically converted to a PostScript screening with the correct Esko dot shape.

- Different rulings / dot shape per separation

In ArtPro files, it is not possible to have screens with different rulings or dot shapes per separation, like you can in other Esko applications. When importing such a file, these settings are split up into different ArtPro screening parameters. The affected objects are then split up accordingly and put on top of each other in overprint.

### About Importing Normalized PDF

Normalized PDF files can be imported just like any other PDF. Keep in mind that in Normalized PDF, image links are included as EskoLinks.

### Page Settings

When opening the **Import PostScript/PDF** dialog box, the **Page** button is selected.

- **Import Page.**

When Import Page is not selected, all pages will be imported.

When Import Page is selected, only one page of the multi-page document will be imported, the one here specified. You can enter a numeric value (a page number) as well as a string (a page label).

For PS files, the PS import has to jump to the right page of the file before starting import of only a selected page (**Selected Only**). However, some applications define crucial information at the beginning of the PS file on page 1. For example: Quark defines all fonts on page 1. Therefore, page 1 is also interpreted (without generating output) before importing the selected page (**First and Selected**). In some poorly constructed PS files, the information needed for the selected page is scattered over the pages in front of it. In that case, use the option **Until Selected**.

- **Ruler at top left**

Learn more about these options in the [ArtPro User Guide \(File menu > Importing PS/PDF\)](#).

- **Multiple Page Offset**

Learn more about these options in the [ArtPro User Guide \(File menu > Importing PS/PDF\)](#).

- **Import Separated File as Multi-page**

This option should be switched off in an action list. It relates to importing a separated file, for example files using the %PLATECOLOR command to identify the separation name or older separated PostScript files.

Learn more about these options in the [ArtPro User Guide \(File menu > Importing PS/PDF\)](#).

### Font Settings

Learn more about these options in the [ArtPro User Guide \(File menu > Importing PS/PDF\)](#).

### Color Settings

Learn more about these options in the [ArtPro User Guide \(File menu > Importing PS/PDF\)](#).

### Blends, Shadings and Gradations

These settings define how gradients, blends and shadings are handled when importing PS / PDF. To recognize gradations from most popular applications, we advise to select both **Recognize Gradations** and **Convert Shadings into gradations**.

Learn more about these options in the [ArtPro User Guide \(File menu > Importing PS/PDF\)](#).

### Links

This determines how links are handled upon import. We distinguish these types of links:

- OPI links (%%ALDImage commands) in PS or PDF files.
- References to EPS images in PS documents.
- EskoLinks.

Learn more about these options in the [ArtPro User Guide \(File menu > Importing PS/PDF\)](#).

### OPI

This section is used to reroute linked images. The rerouting can be done based on the name of the image or based on its path. There are two main reasons why rerouting may be needed:

- Low resolution images need to be replaced by (or rerouted to) high resolution images.
- Missing images need to be rerouted to their correct (current) location.



**Note:** Rerouting can only be done when OPI links are available for the images and the options **Use Link and Place All** or **Use Link and Import EPS** are selected.

- **Perform OPI swap**

When this option is not selected, all below settings are ignored and no rerouting takes place for OPI links.

- **Sample Extension / Hires Extension**

The fields Sample Extension and Hires Extension are used to swap the extension of the linked image. This is typically used for OPI servers which are set to add or replace an extension when they generate low resolution images from high resolution images.

Every extension entered in the Sample Extension field is cut off from the linked file before it is searched. Every extension entered in the Hires Extension field is added to the linked file before it is searched.

Some examples: when the Sample Extension field contains ".lay" and the Hires Extension field is empty and the image that is linked is "image.lay", then the system actually searches for "image", the ".lay" extension is cut off.

When the Sample Extension field contains ".lr" and the Hires Extension field contains ".hr", and the image that is linked is "image.lr", then the system actually searches for "image.hr", the ".lr" extension is cut off and the ".hr" extension is added.

It is also possible to enter multiple extensions, separated by spaces. When the extension of a file referred to in the link matches an extension entered in the Sample Extension field, the extension is

cut off and, when present, it is replaced by the extension in the Hires Extension field at the same position. Extensions that only need to be cut off and not replaced should be at the end of the list.

For Example:

- Sample Ext. field: “.lr .low .lay”
- Hires Ext. field: “.hr .high”

This results in:

- “.lr” is replaced by “.hr”
- “.low” is replace by “.high”
- “.lay” is cut off.

• **Sample Folder / Hires Folder**

Similar to the fields Sample Extension and Hires Extension, these fields serve to reroute the search for an image to a folder different from the folder determined in the OPI link. In OPI swapping environments, this is typically used for OPI systems that generate low resolution images of high resolution images with a same name but in a different folder.



**Note:** For example: all low resolution images are stored in a folder “ForLayoutUse” and all high resolution images are stored in the folder “Originals”, both under the same subdirectory, then “ForLayoutUse” would be filled in the field **Sample Folder**, while “Originals” would be filled in the field **Hires Folder**.

When the OPI link in the file is then: E : /CustomerX/Images/ForLayoutUse/Image, the system will search for and use: E : /CustomerX/Images/Originals/Image .

It is also possible that one path is changed twice. To do this, enter multiple entries in the fields Sample Folder or Hires Folder separated by spaces. This requires that there are no spaces in names of folders that need to be replaced.



**Note:** For example, when the Sample Folder contains “LR Customer” and the Hires Folder contains “HR”, then the OPI path E : /JOBNR/ImagesCustomer/LR/Image is replaced by E : /JOBNR/Images/HR/Image .

In above examples, it is clear that all OPI paths were generated by a system on Windows. The above would work for cases where the workstation creating the PS or PDF file with OPI links is based on Windows and has the same mount point and drive letter for the image server as Automation Engine. As in the first example, for both Automation Engine and the Windows workstation, E : / is the network drive for the image server entered at the mount point where the CustomerX folder is the first available subfolder.

Most prepress workstations are on Mac OS. And when workstations are on Windows, they would often have a different mount point to the image server than Automation Engine. In these cases, the Folder Mapping mechanism can be used to remap the drives for the OPI paths.



**Note:** An example to illustrate this: Suppose the Image Server uses this structure for the images: E:/Server/Images/...

And suppose that the Images folder has been made available to the Macs as Image Server.

And suppose that the Server folder has been made available to the Automation Engine server and that this folder is mounted as a network drive under G:/.

When now an OPI link on the Mac is defined as: ImageServer:image then Automation Engine actually needs to find: G:/Images/image To achieve this, we would enter "Image Server:" in the field **Client**, while entering "G:/Images/" in the field **Server**. Then click **Add** to add this definition to the mapping list.

It is possible to have multiple OPI folder mappings active at the same time. The system equally automatically converts between Mac and Windows notation of subfolders (: and /).

- **Search missing images in... Root Folder**

When a linked file cannot be found at its original or rerouted location, the file will be searched for in the folder or volume that is defined as Root folder and in all its subfolders. Click to define a Root Folder. Click to remove it.



**Note:** The more subfolders the Root folder contains, the more time it will take to search through all these. Therefore, setting a complete hard disk of a huge folder tree as root folder is possible, but not advised.



**Note:** Be aware that the action uses the first instance of the file that it finds, which may not be what you wanted.

For example: suppose the image to be found is called "logo.TIFF" and it is not found at its location, after which the searching starts. Suppose these two customer folders contain an image with that name: RootFolder/CustomerA/Images/logo.TIFF and RootFolder/CustomerB/Images/logo.TIFF.

The system always picks the first instance of the name that it finds, in this case the logo of customer A.

- **Exclude Folders from Search**

The here defined folders will be excluded from the search. For example you here define all folders named "ForLayoutUse", which contain low resolution files.

### Image Settings

- **Vectorise Bitmaps: Always / Most / Never**

When importing a PostScript or PDF file containing 1-bit images or a 1-bit image is detected via OPI, this setting defines how to handle those.

Learn more about this option in the [ArtPro User Guide \(File menu > Importing PS/PDF\)](#).

- **Make Images Internal**

After importing, all TIFF and JPG pictures (placed in the PostScript or PDF file or extracted by Automation Engine) can be automatically converted into Internal Images in ArtPro, by selecting the option **Make Images Internal**. It is only used in exceptional cases. Esko advises to not use this feature. For more information on internal images, see the [ArtPro User Guide \(Contone Menu\)](#).

- **Extract included images**

If an image has to be extracted on disk during PS/PDF import (see also Links), a file is saved to disk. During Import, identical images are detected and deleted. This means that, if Automation Engine extracts images from the PS or PDF file and writes them to disk, these images are compared and if the same image is used several times, only one of them is kept. The comparison is done after writing the TIFFs and before making them internal (if necessary). This comparing can take some time but results in faster editing and smaller file sizes.

Click the **Template Editor** button to define the location and name of the extracted images of the PS or PDF file. When these fields are empty, the images are saved to the folder of the current file. We advise to use the document page number in the template, as otherwise some files can be overwritten with multi-page PS import.

- **Resolution / Detect Image Resolutions**

Learn more about this option in the [ArtPro User Guide \(File menu > Importing PS/PDF\)](#).

- **Use Original Name**

Learn more about this option in the [ArtPro User Guide \(File menu > Importing PS/PDF\)](#).

- **Use Photoshop clipping path**

Learn more about this option in the [ArtPro User Guide \(File menu > Importing PS/PDF\)](#).

- **Recognize TIFF Channels**

Learn more about this option in the [ArtPro User Guide \(File menu > Importing PS/PDF\)](#).

### General Settings

- **Clip Text**

Learn more about this option in the [ArtPro User Guide \(File menu > Importing PS/PDF\)](#).

- **Merge Equal Paths**

Learn more about this option in the [ArtPro User Guide \(File menu > Importing PS/PDF\)](#).

- **Merge Equal Layers**

Learn more about this option in the [ArtPro User Guide \(File menu > Importing PS/PDF\)](#).

- **Ignore Page Commands**

Learn more about this option in the [ArtPro User Guide \(File menu > Importing PS/PDF\)](#).

- **Keep Strokes**

Learn more about this option in the [ArtPro User Guide \(File menu > Importing PS/PDF\)](#).

- **Autostroke CAD lines in ARD files**

When selected, CAD lines in ARD files are converted to strokes.

- **Memory**

This parameter indicates how much virtual memory is allocated for this Import action to store its variables, key words, dictionaries, etc. The proposed default should be sufficient to perform the function. However, when the error message appears mentioning `VMEMORY`, then increase this value and try again.

### Certified PDF

- **Importing file types other than PDF**

The 'Sessions' log indicates that no input profile was applied, The session then begins *after* the import.

- **Importing non-Certified PDF**

When importing a non-Certified PDF file and **Certified Import** is selected, the action certifies the PDF and imports the Certified PDF instead of the original PDF. Unless **Overwrite input file on re-preflight** is selected, a new certified PDF is saved (according to the settings in the Template Editor dialog) and this certified PDF is imported. This is saved as a separate session.

- **Importing Certified PDF**

- When **Re-Preflight if profile does not match** is selected:

When the input profile and the embedded profile do not match, the file is re-preflighted (when comparing two profiles, their content is checked, not just their name). When they do match, the session log indicates that both profiles are identical.

- When **Re-Preflight if profile does not match** is not selected:

The Certified PDF is imported without re-preflighting it. The task details indicate the profile it was originally certified by.

- **Re-preflighting**

When re-preflighting, the action creates a new session, preflights the file and closes the session. The file is saved according to the settings in the Template Editor dialog.

- **Overwrite input file on re-preflight**

When selected, no new PDF file is created, it then replaces the original PDF file.

- **Get all bounding boxes for preflight report**

When selected, this forces the action to obtain bounding boxes for the last preflight report. It then gets full information for every report item along with the bounding box of the area where the error or warning occurred. The action then takes longer because this causes an additional preflight of the input file.

### Cruise Controls (ArtCruise)

Cruise Controls allow you to control the status of many aspects of this Import action. This status also maps to the status of the [Apply ArtPro Action List task](#) that uses this action.

The many controls are available in seven categories. The right window shows the selected controls, each with a green, orange or red circle in front. The color determines the severity of the control: red refers to error level, orange to warning level and green to note level.



**Note:** When a cruise control topic results in an error, the Import action will continue until it is completed.

To change the severity level for a cruise control topic, select it and choose the wanted severity level from the drop-down list. To add a topic to the list on the right, double-click it in the left window. To remove a topic from the list, right-click it and select "Delete Control" or select it and press `Delete / Cmd - Backspace`.

The buttons **Save Controls**, **Clear Controls** and **Load Controls** respectively allow to save all the selected controls with their severity level to a file, clear the list or load controls and their severity level from a previously saved file.

When the import action has finished, the saved file contains a complete Cruise Report (similar to a preflight report). You can view this report in ArtPro and there navigate to the object that triggered that specific entry in that Cruise Report.

When **Save Report** is selected, a PDF report is saved to the location specified in the Template Editor. You can use a Select File action to select that report PDF and use an E-mail action to mail it as an attachment.

Learn more about cruise control in the [ArtPro User Guide \(File menu > Cruise Control\)](#).

### 13.5.33. Ink Coverage

This action calculates the file's ink coverage and provides it in a text file (use the Template Editor to specify its name and location).

Per separation in the file, a value is given as a percentage and as a surface coverage (for example in square mm). A total surface value is also mentioned.

The accuracy of the calculation is determined in **samples per inch**.



**Note:** In the case of pictures, ink coverage only works when these are mapped pictures or when placed ArtPro pictures contain a separated preview. In other cases an average value is used. On board ArtPro, this average value can be adapted in the paint style.

### 13.5.34. Ink Coverage Check

This action verifies if the amount of ink does not exceed the **Ink Limit**.

You can specify the area (page box) and resolution at which that area of the file needs to be rasterized for checking. You can exclude special separations such as opaque, die or transparent ones.

### 13.5.35. Insert ArtPro file

This action inserts an ArtPro file or picture into the file that is currently being processed.

The inserted file can either be

- a fixed file (which name is selected in the **Select ArtPro File** dialog)
- a file specified by a preceding **Select File** action).
- a file that was generated earlier in the action list. For example the result of a **Difference** action that needs to be inserted in a new ArtPro file (placed as picture).

The insertion is done on the bottom right quadrant of the current position of the ruler, determined by the position of the ruler in the **Importing** action, the position of the ruler in an opened ArtPro file or the position of the ruler after the **Move Ruler** action.

**File:**

Click  to specify a file or specify it in a preceding **Select File** action in the action list.

**Overwrite separation angles and frequency**

When inserting an ArtPro file, new separations are added. When there are identical separations, this option overwrites the angles and frequency of the current separations with those of the file that is being inserted.

### Merge Layers with Same Name

When selected, the content of layers in the inserted ArtPro file is merged with content of layers in the current file that have the same name.

### Ignore Screening Errors

Because Extended Screenings are stored differently in newer versions, opening a file from an old version may result in a conversion of the screening. If this conversion fails, the action fails, unless the **Ignore Screening Errors** option is selected. Because a conversion error means that the screening settings have changed, we advise to use this option only for action lists that do not have any screened output or when other screening settings are defined in the action list itself.

### Place as picture using

This is used to place image files or to treat an ArtPro file as a picture (which could be done when the content of the ArtPro file is not available, for example for trapping or internal modifications).

These picture types are supported: EPS, DCS, TIFF, PSD, ArtPro, PS, PDF and TIFF/IT.

When this option is selected, choose the page box from the list. At the time of inserting, a rectangle is created of the same size as the border of the chosen page box, in which the file is placed as a picture. Use the option **Align picture on** to define on what page box the placed file should be positioned. The top left corner of the selected page box is placed in the center of the ruler.

For example: combining both options allows you to place the inserted file positioned on its trim box (top left corner of the trim box in the center of the ruler), but placing it inside it's bleed box.

### Place Single-Separation ArtPro File in Single Separation

This option defines how to handle inserting ArtPro files with only one separation. If this option is not selected, objects in the ArtPro file with 100% of the single separation are considered to be registration color. Thus they get 100% of every ink in the ArtPro file after insertion. If this option is selected, the file is inserted in one single separation instead.

### Recognize TIFF Channels

This option allows to recognize TIFF channels when inserting a TIFF File.

This option is also part of the Import action. Learn more in the [ArtPro User Guide \(File menu > Importing PS/PDF > Image settings\)](#).

## 13.5.36. Join

This action joins the two nearest open points of the selected paths with a straight line. This is repeated until no open points are left.

## 13.5.37. Layer Versioning

This action allows to create multiple ArtPro files from a single file, based on its layers. The **Base Layers** re-appear in every output file. **Version Layers** only appear in one specific output file. This can be used, for example, to split up a file with layers "Base graphic", "Base Text", "English", "French", "German", into 3 files: everyone having the Base layers and one with the French, one with the German and one with the English layer.



### Base Layers

Click **+** or **-** to add or remove selected layers. Specify their name after double clicking the default name. You can use wildcards (\*).

When you **Select by Range**, you can, for example, define that layer 1 – 3 are base layers.

### Version Layers

**Version Layers** can be defined by a user or you can choose to use **All Non Base Layers**.

Each version layer entry will create an output version. Use the **Template Editor (Output button)** to define their names. For every version, you can define what layers need to be used.

The option **Ignore Case In Layer Names** defines whether the matching of the layer names is case sensitive or not.

Select **Fail if extra Layers found** if you want the action to fail when layers are found other than the ones defined in the versions and base layers.

You can define if the output ArtPro file needs to be saved with a preview and if the Certified PDF information should be included.

## 13.5.38. Make Compound

This action makes one single object of all the selected paths.

Where paths are overlapping, a look-through window to the background is created.

Learn more in the [ArtPro User Guide \(Object Menu > Compound\)](#).

## 13.5.39. Make Thumbnail

This action creates a TIFF or JPEG thumbnail version of an ArtPro file.

The maximum resolution you can set is 120 ppi. You can add **Noise for Gradation**. There is no oversampling. Choose the preferred **Compression**.

## 13.5.40. Modify Layers

This action allows to change the settings of layers. Add any number of layers, specified by name. You can use wildcards (\*).

When **Matching** is selected, all layers matching the entered string are affected. When it not selected, all layers *not* matching that string are affected. This for example allows to select all layers except "varnish\*".

Use the check boxes to set layer(s) to (in)visible, (un)locked or (non-)printing.

When a layer name is not found, the line is ignored. However, when the **Abandon** option is selected, the rest of the action list is abandoned.

Layers with hidden, locked or non-printing checks stay like that until other **Modify Layers** actions remove the check or until the action list closes the ArtPro file.

### 13.5.41. Modify Paint

This action allows to modify the paint (in percentage of a given separation) of all or selected objects, change its overprint, or modify the start and end color of gradations.

### 13.5.42. Modify Screen

This action applies user defined screening parameters to all or selected objects.

**Use a Screening set** allows to select a screening set as saved in ArtPro, based on the name in the **Screen** field. The file can be selected using the **Browse** button. Learn more in the [ArtPro User Guide](#).

These screening parameters are PostScript based. Use the **Dot Code** field to enter a PostScript string to set your own personalized screening.

### 13.5.43. Modify Separations

This action allows to change settings for separations.

#### Rename C/U/CV/ CVC/CVU/CVP to

This allows to rename different CVC flavours to having a same extension.

#### Delete CMYK Flags

CMYK flags indicate what separations should be handled as CMYK (for placing pictures, importing PS files, etc.) even if they are replaced by spot colors. Select this to delete them.

#### Separation list

Click **+** or **-** to add or remove specific separations and a specific action to apply on those. You can use wildcards, for example: `"Die*"`.

#### Rename

Enter the original and the **Set to** (target) name and select the option **Rename**.



**Attention:** Renaming is *not* the same as remapping (see below).

#### Create

Enter a name and select the option **Create**.

#### Set to

- **Remapping**

To remap a separation, enter its **Name** and the name of the target separation in **Set to** (and make sure you do not select 'rename'). When the target separation does not exist, the action will fail.

- **Convert to CMYK**

To convert a separation to CMYK, enter its **Name** and enter CMYK in **Set to**.

- **0 / Trans**

A separation is set to knockout when you enter "0" in **Set to**. All objects containing "trans" for that separation are then changed to "0".

When you enter "trans" in **Set to**, the separation is set to overprint, changing all "0" values to "trans". The **Apply on Selections Only** can be used to set the desired separation to 0% or Trans only for the selected objects.

- **Opaque / Technical / Varnish**

Sets the attribute of that separation to either opaque, technical or varnish (transparent).

This attribute is used in JDF export and in the action [Vector Trapping](#).

### 13.5.44. Move Ruler

The ruler position of a file depends on how the ruler position was set when importing or opening that file.

The **Move Ruler** action moves the ruler within the current file to a new position based on an offset versus the current position or versus a chosen page box.

This is very useful when pictures or other files need to be added to the current file at an offset.

### 13.5.45. Nested Step and Repeat

This action is based on ArtPro's module PowerStepper. It is used to step and repeat based on a multi-step CAD file: MFG (ArtiosCAD), CFF2 or a DDES file. These files decide the position of the stations, their rotation and any possible nesting. Learn more in the [ArtPro User Guide \(Prepress menu > Step and Repeat Nested\)](#).

The action typically needs two files as input: the CAD file and the ArtPro file. The CAD file can also be specified within this action.

#### Nested Layout File Format

Instead of selecting an ArtPro file, you can also select a 'layout' file: a file describing the names of the station files and where to place them.

Layout files are tab-separated text files with a small header. An example:

```
ArtPro Nested S&R Layout V1.0
```

```
JokerBoxBerries.aw 1-3 5
```

```
JokerGreen3.aw 4 6-7
```

The first line identifies the file as a 'layout' file that can be used for Nested S&R. It is followed by an empty line. Each next line contains the file name of a station and the station numbers at which it should be placed. In above example, the file 'JokerBoxBerries.aw' is placed at station numbers 1 through 3 and 5 and the file 'JokerGreen3.aw' is placed at station numbers 4 and 6 through 7.

When using a layout file, you can provide the station files using a **Select File** action before this action and then deselect the option **Filenames in Layout File must match**.

### 13.5.46. Open ArtPro File

When this action is the first one in an action list, it opens the input file of the task. When this action is preceded by a **Select File** action, it opens the selected one.

An ArtPro file can contain, next to its line art content, also a CT portion (internal images). Alternatively, an ArtPro file can contain linked images (not embedded).

This action offers functionality related to used images, used fonts and color management.

#### Root Folders

When images were used that reside on a Mac workstation or on a server which can not be made accessible to Automation Engine, the Root Folders functionality can be used to define where these images are.

An example: a root folder was defined as: `E:/AE/AP_files`. When an ArtPro file is opened that contains linked images which were previously stored on a local Mac, they first need to be copied to this folder or a subfolder of this folder.

When you define multiple root folders, the action then searches through all these folders and their subfolders until the image is located. You can drag and drop lines to re-arrange their order.



**Note:** When you defined one, click on the folder icon on the right to open the Template Editor and add SmartNames to your definition.



**Attention:** The folders that the Automation Engine server needs to access do not have to be (part of) Containers. However, they have to be accessible for Automation Engine's system user (which is by default "BGSystem").

#### Folder Mapping

**Folder Mapping** can be used when images reside on a server that can be mounted by Automation Engine (also see above note on AE's system user).

An example: In an ArtPro file, the path of an externally linked image is defined as:  
`Intel_Mac:images:image1.`

On the Automation Engine server, this file server will be mounted at a different mount point with a different name. Typically the image server would be mounted to a drive letter, for example `G:`.

To allow Automation Engine to automatically locate images on the Image Server, you can use **Folder Mapping** to substitute a portion of the path name used in the ArtPro file with another name. In our example, `Intel_Mac` would be substituted with `G:/`, which would instruct Automation Engine to find above image as `G:/images/image1.`

To define a **Folder Mapping**, enter the respective **On Client** field (how the local Mac sees the file server) and its respective **On Server** field (how Automation Engine sees the file server) and click **Add**.

#### Fonts Folders...

When the ArtPro file contains live text, you can use **Fonts Folders** to allow Automation Engine to extract the outline information from the Mac fonts for trapping, printing, exporting, ArtLink functionality, etc. Please note this is only valid for Type 1 fonts and TrueType fonts.

Although the ArtPro file format contains all the outline information for its live text, the font is still important for special functionality like ArtLink, Regmarks, etc. Click on the folder icon next to a font folder to open the Template Editor and add SmartNames to your path.

### Color Management

When enabling color management, you can select a color management settings file that was previously saved by ArtPro. This file contains all ICC profiles and settings to determine how color has to be treated throughout the rest of the action list, including ICC profiles for proofing, printing, etc.

When the option **Stop when working space profiles are different** is selected, the action stops when the ArtPro file itself contains a working space different from the one defined in the Color settings file.

### Map Pictures

When selected, images are converted to mapped pictures when possible. Learn more in the [ArtPro User Guide \(Window menu > Paint Style > Mapped Picture\)](#).

### Ignore Screening Errors

Learn more in [Insert ArtPro File](#).

### Make image names SMB Compatible

Select this option to replace all a hash tags ( # ) in names of linked images by an underscore ( \_ ). This will make them compatible with a Windows file server. When you do this, the ArtPro file should be saved to make its image links point to the renamed images.

## 13.5.47. OPI Generation

This action generates low resolution images from high resolution images. This is typical in a page imposition workflow.

When a file is printed with **Omit Images**, the **Importing** action can then recognize the OPI comments in the PostScript or PDF file and reroute back to the high resolution images.

## 13.5.48. Optimizing

This action deletes (parts of) the contours that are not needed to produce correct print output. The function is used to clean or flatten a document, removing all the superfluous and unnecessary paths. For each path the action checks all the contours on top of it and decides which objects should be cut, united or left untouched to maintain the same structure in the file.

Optimizing is especially useful to eliminate unnecessary contours from an imported PostScript file, to perform faster trapping, faster printing, etc.



**Attention:** Keep in mind that objects are typically less editable after optimization. We therefore only recommend to use this action for complicated graphics.

### 13.5.49. PowerTrapper

The **PowerTrapper** action offers these main options:

1. Choose your trapping settings in the tabs **Distance & Direction**, **Color & Shape** and **Processing**.
2. Optionally, click **Add Rule** to add trapping rules.
3. **Save** your trapping settings as a **Trap Preset** to easily reuse them on another file.

Learn more in the [ArtPro User Guide \(Prepress menu > PowerTrapper\)](#).

### 13.5.50. Print to File

This action converts the ArtPro native file format to a composite or separated EPS file, depending on the **Device Type** that has been chosen.

In an action list, the **Print to File** action can be simply followed by a **Close File** action, or the Automation Engine task that launches this action can continue with an FTP or a Copy task that then sends the output file to a device. .

#### General Concepts

Learn more in the [ArtPro User Guide \(File menu > Print : General Settings > General Concepts\)](#).

#### Device Type

Learn more in the [ArtPro User Guide \(File menu > Print : Device Types\)](#).

#### Other Settings and 'More Settings'

Learn more about all other options in the [ArtPro User Guide \(File menu > Print : General Settings - Settings\)](#).



**Note:** Some paragraphs in the ArtPro User Guide refer to options in ArtPro Action Lists as 'Nexus' options.

### 13.5.51. PrintCheck

This action creates an image of the complete file. This image serves print control systems.

You can choose the resolution (no maximum) and set a noise level for gradations. You can choose the format, compression and the page box to be converted.

### 13.5.52. Regmarks

The action allows to select a 'marks' file you made earlier and add these marks to the current file. This marks file is a blank ArtPro file containing only marks. Its job size is not relevant. The marks will automatically adapt to the job size of the current file and the inks will also be adapted.

You can select a fixed file by using the **Select File** button in this action, or you can select a variable marks file by using the **Select File** action before this one.

Learn more about building a marks file in the [ArtPro User Guide \(File menu > Import marks'\)](#).

Choose on what page **Box** the marks need to be applied or choose to use the bounding box of prior made selections.

When **Merge Layers** is selected, layers in the marks file and in the current file with the same name will be merged together.

### 13.5.53. Reorder Layers

This action allows to change the order of layers.

Layers with a name that matches one of the entries are placed in the specified order. Other layers are placed underneath in their original order.

Use the **+** and **-** buttons to add or remove layer names. A name can contain a wildcard (\*).

When two different layers match the same entry, their relative order depends on the original order.

When a layer name matches different entries, the best match is chosen. For example: a layer name "Trap layer" matches more with "Trap\*" than with "\*".

Select **Ignore Case** when the matching should ignore any case difference in the names.

### 13.5.54. Reorder Separations

This action allows to change the order of the separations in the file's **Separations** list.

Separations with a name that matches one of the entries are placed in that specified order. Others are placed underneath, in their original order.

Use the **+** and **-** buttons to enter names. A name can contain a wildcard (\*).

When a separation matches two different entries, it is placed at the topmost position. When two different separations match the same entry, their relative order depends on the original order.

**Reverse order** is useful for some special printing processes like dry offset. When selected, no other re-ordering can be done.

### 13.5.55. Rich Black

This action allows to add extra color to black objects (all or selected). Typically, the black is enriched with cyan.

**Density** is the value of the chosen ink that you will add. **Min. density** decides which black objects you want to enrich. For example: You can add 50% cyan to black objects with a minimum density of 90%.

Select **Pure ink only** to only enrich objects that only contained black (till then).

### 13.5.56. Save ArtPro File

This action saves the currently processed file as an ArtPro file.

**Output**

Use the Template Editor to set a (smart) location and name.

**Compatibility**

Choose the file's compatibility. Saving as an older file format may trigger a conversion of object types that did not exist yet in that older format. For example: a v9.0 file saved as v7.5 will not contain blend modes ; that file will be *flattened* before saving.

**Include Preview**

Select **With Preview** to get a (separated) preview included in the ArtPro file. This preview is useful when making Step & Repeating this file in ArtPro. The default **Resolution** is 72 ppi.

**Save Hidden Layers**

When this option is not selected, layers with a "hidden" state will not be included in the saved file.

**Profiles**

**Embed entire profile in ArtPro files** allows to include the used **Color Management** profile in the ArtPro file. This is useful when moving files to another system. The option **Don't embed profiles for imported pictures with embedded profiles** disables embedding profiles that are already embedded in the pictures.

**Flattener Options**

When saving the file as v7.5 or older, the file will be flattened with the settings in **Flattening Options**. When the flattener generates images, their location and name is defined by the **Template Editor**. Learn more in the [ArtPro User Guide \(in Prepress menu > Flatten transparencies, and also in ArtPro menu > Preferences > General: Flatten\)](#).

**Certified PDF sessions information**

Select **Include Certified PDF information** to include Certified PDF information in the ArtPro file. This also happens when saving as ArtPro 7.5 file, but that information is ignored when opening that ArtPro 7.5 file.

Select **Save Certified PDF Information** to save the Certified PDF information in a separate XML file. Use the **Template Editor** to define its name and location.

**13.5.57. Select File**

This action is used in an action list to define a selection of file(s) which should be used as input for the next action in the list.

**Select Options**

**Select Options** show the list of criteria that you created. Use + and - to add or remove criteria. The name automatically summarizes its main settings (as shown below in **Select Item Options**).

**From Inputs / From Actions**

- **From Inputs:** the files you select are searched from the inputs files of the ArtPro Action List task that this action is part of.
- **From Actions:** the files you select are searched from the output files of all or a specified action in this action list. You can specific that action by typing in the **Label** that you gave it.



### Select By Name

- **whose name**

The system selects a file based on its name. Choose a selection parameter from the list. You can also use **Regular Expressions** in this input field. The **Template Editor** allows to specify smart names.

- **Position From... To... 0 To 500**

This field work in combination with the option **Whose name contains...** Using the position fields, you can specify what character positions of the file name will be checked. For example: With **Whose name contains** as "APR" from position 2 to 4, files which have APR on character position 2 to 4 are searched and selected. Mind that the first character is seen as on position 0, so in this case the 3rd, 4th and 5th characters are searched.

### Select By Documenttype

- File Type

An ArtPro, PDF or PS file that also matches the other criteria.

- Number of Separations

Specify the **Number of Separations** that the selected file should have.

- Number of Pages

Specify the **Number of Pages** that the selected file should have.

- Page Box

Specify a size of a chosen page box that the selected file should have.

- Orientation

Specify the page orientation that the selected page box of the selected file should have.

## 13.5.58. Select Objects

This action allows to select and deselect objects.

### First

Choose what should be done prior to the selection:

- **Do nothing** means leaving the current selection as is. This is useful when combining multiple **Select Objects** actions.
- **Invert Selections** inverts the current selection prior to applying the one in this (new) select action.
- **Select All** or **Deselect All** allows to start from scratch with either everything selected or everything deselected.

### (De-)Selecting

The radio buttons at the bottom define whether the criteria you enabled means that you want to select or deselect these objects.

- Using **Within Selections** in combination with **Select** will search for objects that match the defined criteria inside the current selection. Objects that do not match these criteria are deselected.

- Using **Within Selections** in combination with **Deselect** will search for objects inside the selection that match the defined criteria. Objects that do not match these criteria remain selected.

Use **Fail if Number of Selections...** to have the action fail if the number of selections is higher than, lower than or equal to the entered value. Use this for example to have the action fail if any selected text is smaller than 7 pt..

### Paint Style

- **Flat Paints.** Allows to (de)select **Flat Paints**. Specify which ones in the option **Matching** (see below).
- **Gradients.** Allows to (de)select **Linear, Circular** or **Multistep gradients**. This can be used in combination with the **Matching** option (see below).
- **Matching.** The **Matching** panel allows to specify objects with a **Flat Paint** or a **Gradation** within the defined percentage range. Separation names can contain wildcards. Enable **Overprint** to specify objects that are transparent for that specific separation.
- **Pictures.** Allows to (de)select placed, mapped or pattern pictures.
- **Images Type.** (De)selects all placed files of the chosen file type.
- **Images Color.** (De)selects all placed files of the chosen color type

### Transparency

- **Blend Mode.** (De)selects all objects with the specified **Blend Mode**. Choose **All** to (de)select all objects containing any blend mode.
- **Opacity.** (De)selects all objects with the specified opacity.
- **Opacity Masks.** (De)selects all objects containing a soft mask.
- **Objects / Groups with Transparency.** (De)selects all objects or groups containing any transparency.
- **Overprint.** (De)selects all objects containing overprint.

### Objects

- **Text.** (De)selects all text with the specified point size. **Vectorized Text** also (de)selects text that was converted to outlines during import or by using the action **Text to paths**.
- **Font Name.** (De)selects all text items or text blocks containing the specified font. A text item containing more than one font, is selected completely if the specified font is used.
- **Screen Name.** (De)selects all items using the specified screen settings.
- **Object Name.** (De)selects objects with that name. For example a layer from an imported MFG file that was imported as a sub-layer in ArtPro.
- **Strokes.** (De)selects the strokes as specified.
- **Traps.** (De)selects all traps created by automatic trapping. A trap that was edited is no longer recognized as a trap and thus not (de)selected.
- **Barcodes.** (De)selects all barcodes containing barcode information. Mind that some transformations make barcodes invalid (un-proportional scaling for example). A warning is given when transforming and when the barcode is no longer selected with this function.

- **Thin Part Fixes.** (De)selects the thin part fixes done in ArtPro.
- **Slices.** (De)selects all slices (used for rid Warping).
- **Open Paths.** (De)selects all paths that are open.
- **Blends.** (De)selects all blends.
- **Link.** (De)selects all objects containing a link for [ArtLink](#).
- **Objects Inside / Outside bounding box.** (De)selects objects inside or outside the specified pagebox.
- **Layers.** (De)selects objects that are in a layer that (does not) match the entered name. The layer name can contain wildcards.

### 13.5.59. Separate

This action separates the file into its separations and places them under and next to each other in a single ArtPro file.

You can define the **V / H Gap** to be left in between the separations. The number of **Columns** defines how many separations you want to place next to each other.



**Note:** When you want to print this kind of “separated” file, make sure you select the option **All Separated Pages on Same Film** (in the **More Settings** of the **Print to File** action).

### 13.5.60. Set Station Numbers

This action allows to set station numbers onto an step and repeat file. It is based on the **Station Number** part of the [Nested Step And Repeat](#) action.

Use the square buttons to define the origin for the **Offset**. By default, the station numbers are centered on the bounding box of a station.

Use the **Template Editor** to define a smart text for the station numbers.

Learn more about station numbers in the [ArtPro User Guide \(Prepress menu > Step and Repeat nested > Station Numbers\)](#).

### 13.5.61. Spread

This action allows to apply a spread on all or selected objects. It is based on the **Interactive Trapping** function in ArtPro. Learn more in the [ArtPro User Guide \(Prepress menu > Interactive Trapping\)](#).

When a **Spread** is applied:

1. The paint style of the original object is changed to 0% for every separation.
2. A slightly larger **Spread** object is generated.
3. The **Spread** object gets the paint style of the original object, but is changed to “trans” for every separation that had a 0% value.
4. If the original object had a blend mode, the original and spread object are grouped and the blend mode is applied on the group.

### 13.5.62. Tabular Step and Repeat

This action allows step and repeat in a tabular way. Learn more in the [ArtPro User Guide \(Prepress menu > Step and Repeat Tabular\)](#).

This action can step ArtPro, TIFF, EPS, DCS and PDF files. These can be an input file of the action list itself or can be picked up by a prior [Select File](#) action.

When an ArtPro file and a **marks** file are bundled in a folder, the **Select File** action would then select the ArtPro file (or any other of the supported formats), and be followed by a **Select File** action to select the **marks** (ArtPro) file that will be used to generate the register marks.

In **Use Box**, you define which page box needs to be used as reference for the step distance.

#### Settings

- **Count.** H and V amount of instances of the stepped file.
- **Begin Pos.** H and V offset to the ruler position for the first instance of the stepped file.
- **Step.** When left on (0,0), the step distance is equal to the (below) selected page box of the stepped file.
- **Angle Setting.** Rotation of the stepped file.
- **Cut Marks.** Adds **Cut Marks** to any of the stepped instances.
- **Keep Bleeds.** Keeps the bleed of the stepped file in the step and repeat file. Bleeds are always kept outside of the step and repeat job size. Note that bleeds overlap when the step distance is set to the Trim box.
- **Place Single-Separation ArtPro File in Single Separation.** When this option is not selected, objects in this AP file with 100% of the single separation are considered to be registration color and thus get 100% of every ink in the repetition. When this option is selected, the file is inserted in one single separation instead.
- **File & Font Settings.** This gives access to the root folders, folder mapping and fonts folders when the file to be stepped is an ArtPro file. Learn more in the [Open ArtPro File](#) action.
  - **Color Management Settings.** When you wish to enable color management for the step and repeat file, select a color management settings file (that was previously saved in ArtPro). This file contains all ICC profiles and settings to determine how color has to be treated throughout the rest of the action list (example: proofing of the step and repeat document), including ICC profiles for proofing, printing, etc.

### 13.5.63. Text to Paths

This action automatically converts all the (selected) text to outlines. This is useful when exporting ArtPro files to environments where the fonts are not available.

Note that when importing PS or PDF files, text could already have been converted to outlines (when the option **Convert to Real Text** was not set during **Importing**).

### 13.5.64. Transform

This action applies a transformation to all or selected objects in the file. You can move (**Distance**), **Scale**, **Rotate** or **Shear** objects.

### Options

- **Repeat.** Use this to execute the transformation multiple times.
- **Copy.** This copies the contents of the file before executing the transformation. If at the same time repetition is set, there will be multiple copies.
- **Apply on:**
  - **Path, Paint, Soft Mask:** These options determine if the objects and their contents are transformed, or only the contents without the objects, or the objects without the contents. For example if a clipping path with an image would be transformed and Path is not selected, then only the image itself is transformed and not the clip path.
  - **Notes.** Transforms the notes along with the rest of the file, so that the positioning of the notes inside the file remains the same.
- **Scale Strokes.** When not selected, the stroke width does not change when scaling. When selected, the stroke remains a stroke and its width is changed for the same percentage as the parent path was scaled. For example, scaling an object with a 3 mm stroke to 150%, results in an object with a 4.5 mm stroke. When scaling is un-proportional, the stroke width is scaled proportionally, by the geometric mean of vertical and horizontal scaling (= the square root of the product of vertical and horizontal scaling).
- **Center Paint** (only available if the **Apply on: Paint** and **Soft Mask** is off). When selected, it transforms the path only, but then repositions the paint based on the center point of the path: the point in the paint that was on the center point of the original path is placed on the center point of the transformed path. For example, this can be used when scaling or distorting step and repeat files, without scaling the contents of the paths, but still retaining their position inside the paths.
- **Use Ruler.** When selected, the center of the ruler is used as the center for rotation and scaling. When not selected, the center of the selected objects is used.

## 13.5.65. Trim & Bleed

This action calculates a trim and/or bleed for all objects in the file. It is mostly used when step and repeating. Learn more in the [ArtPro User Guide \(Prepress menu > Step and Repeat Nested\)](#).

## 13.5.66. Unite

This action creates a union of all or selected paths. Typically, you first use the action [Select Objects](#) followed by this one.

Learn more in the [ArtPro User Guide \(Objects menu > Path > Unite\)](#).

## 13.5.67. Update ArtLink

The **Update ArtLink** action is comparable to the **ArtLink** action. While the **ArtLink** action creates as many versions as there are records in the database file, the **Update ArtLink** action does not create any files or versions. It modifies an object on-board an ArtPro file by updating its ArtLink that was already put there earlier. This action opens the ArtPro file and so re-reads information from the specified database record(s) (defined in the **Record Number** field) or from an the XML file.

Learn about most of its settings on the page of the action [ArtLink](#) on page 920 .

### Additional Key Values

The **Additional Key Values** allow to define values for specific keys. These keys are defined from the action list rather than coming from the database file. For example: this can be useful to set the name of the operator. You can also use the **Template Editor** and even insert SmartNames.

## 13.5.68. Vector Trapping

This action offers an alternative (older) version of trapping technology than the [PowerTrapper](#).

For a full description of its different settings, we refer to the [ArtPro User Guide \(Prepress menu > Automatic Trapping\)](#).



**Note:** In the ArtPro user guide, the trapping modes **Packaging** and **Commercial** are often referred to as 'version 1' and 'version 2'.

## 13.5.69. Vectorize File

This action converts images into line-art.

Learn more in the [ArtPro User Guide \(File menu > Import - Vectorize...\)](#).

## 13.5.70. White Underprint

This action allows to create a white background underneath the selected objects. This white background is often needed when printing on transparent or metal material.

Learn more in the [ArtPro User Guide \(Prepress menu > White Underprint\)](#).

## 14. Sign & Display Workflow

---

### 14.1. Typical features of Sign & Display Printing

---

This chapter is about workflows that enable you to efficiently match graphic designs to be printed with the available substrate (to have as little substrate waste as possible and faster turnaround).

Typical features are [Nesting](#), [Ganging](#) and [Tiling](#). These are especially useful when printing on (large format) flatbed devices or for any short production print runs.

The layouts that are sent to the printer should take into account the designs' sizes, shapes and ordered quantities.



**Note:** Flexo CTP workflow is described in the separate chapter [Flexo CTP Device Workflow](#) on page 1482 .

#### 14.1.1. Nesting

The term 'nesting' is used when laying out several graphic files in the most efficient way so the least amount of substrate is used, this to reduce cost and/or waste. It actually refers to the effect where, when working with non-rectangular graphics, their bounding boxes can be allowed to overlap in the layout.

The technology in Automation Engine that calculates these optimal layouts is referred to as the 'nesting server'.



### 14.1.2. Ganging

The term 'Ganging' is used for a layout that combines graphics that belong to different job orders. The jobs on this layout so temporarily represent a 'gang'.

This 'gang' could as well be made out of different orders from one same customer or even be a combination of orders from different customers.

Here's an example of a ganged layout containing graphics from 2 different job orders. One from the 'green' customer, the other from the 'cars' customer. And yes they are also nesting into each other:



Of course, the technology that makes layouts focusses on the shapes and fill percentage, not who these files are from.



**Important:** In some cases, printing companies or the print buyers themselves insist that jobs from different customers (competitors?) should never be mixed in production. Automation Engine does also offer tools to avoid ganging.

### 14.1.3. Tiling

#### Concept

The term 'tiling' refers to splitting oversize graphics into smaller rectangular pieces (tiles). This can be done with the task [Create Tiles](#).

These smaller tiles are then no longer too large to be printed or now have a size that is easier to manage at the moment the printed tiles are re-united to become one large image (for example a size which a person can carry up a ladder).

Tiling is typically used in the production of billboards:





This graphic for a billboard is often too large to be printed in one piece and actually also for practical reasons too large to be applied to the billboard as one piece.

Here's an example where it is tiled into these 10 smaller parts:

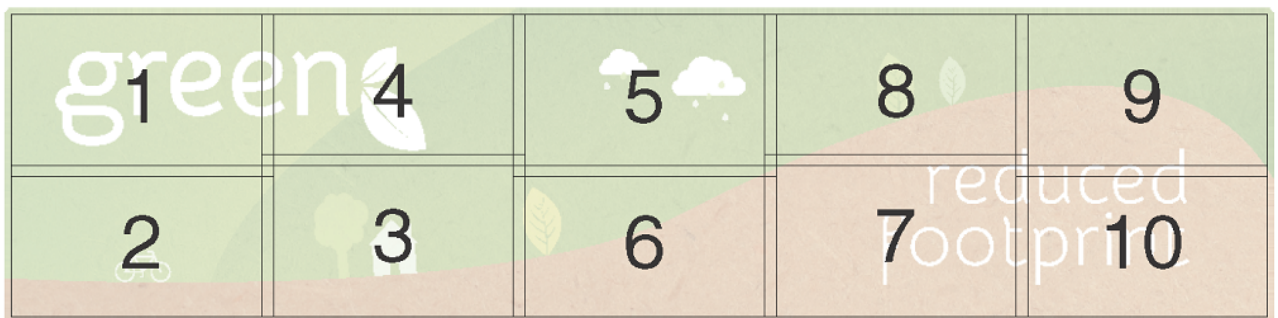

, In case the size of your printing device can handle a layout of more than one tile, you probably will submit the tiles to a queue of the Gang Run Printing mode.

**About Overlaps**

Typical for tiling is the use of overlaps. We distinguish 3 classic concepts:

- Standard **overlap**: a side without overlap is placed on top of the overlap of the neighbouring tile:

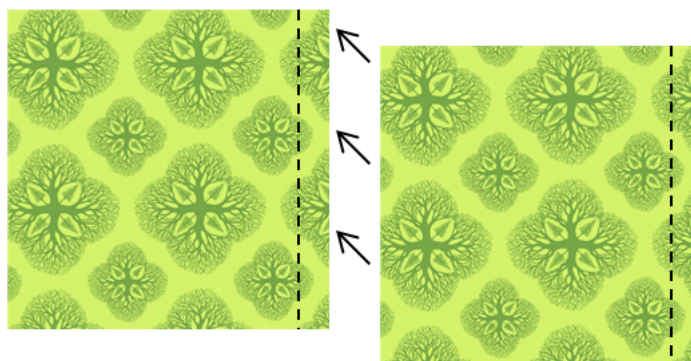

- When producing wallpaper or murals that are applied with a **double cut**, you need an **overlap on both sides**:

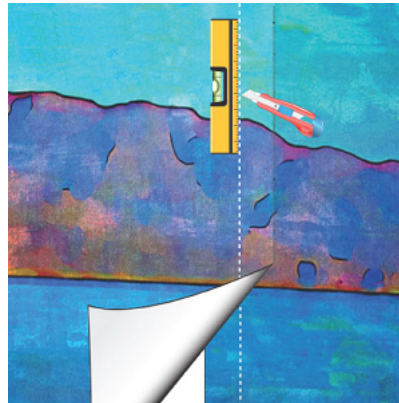

- When producing wall prints in thick material or tiles that are inserted in a framework, you might not need any overlap. An example:



## 14.2. Two modes: Nesting Queues or Nesting Task

---

### Concept

In Automation Engine, the calculation of the 'best' layout is done in background by what is called the 'nesting server'. And of course you can automate all parts of the workflow: the preparing of the one-up graphics, the nesting parameters and the output of the resulting layouts.

The difference in the 2 modes is about the amount of control you want over this nesting server:

- Do you want it to consider other jobs or different substrate sizes to get to the best possible layouts? Do you want some visual feedback of the calculated proposals and/or maybe decide yourself by some manual intervention? We then advise to use the nesting **queues**.
- Or do you want the XML specification from an external system to be respected and only use the nesting server to optimize substrate usage? We then advise to use the nesting **task**.

### The two modes in some more detail

- **Using the Gang Run Printing (GRP) Queues**

This workflow is actually split into 3 parts:

- The **input (prepare) workflow** that ends by submitting one-up(s) to a GRP **Substrate Queue**.
- The GRP **substrate queue** uses the nesting server to propose the best layouts ; manual intervention is possible.
- When a layout decision is made, the queue starts the assigned **output workflow**.

Using the GRP queues, you can process more graphics in parallel, and you don't need an operator to keep checking when to generate layouts (this is done automatically, a bit like when using hot folders).

The GRP queues can also be used in semi-automatic ways, for example by pausing a queue, adding exceptions or by overruling a proposed layout after a visual check.

Learn all about the benefits of this mode further in this chapter.

- **Using the Nesting Task**



**Note:** This mode of working and its task types were available before there was the elaborated Gang Run Printing view and way of working.

- **Control over Layout:**

There are cases where an external system defines most of the attributes of the wanted layout: which graphics need to be on it, how many times it needs to be printed, on which substrate, etc.

When that system exports this specification as an XML file, Automation Engine can use it to create that exact layout.

In this workflow, you do not submit any graphics to a GRP queue, but instead use that XML description as the input file for the task [Create Nested Layouts](#). This task uses the same nesting server as the GRP queues.

Because this specification already exists, there is probably no need to use GRP queues ; other variations or optimizations (like ganging) are simply not wanted.

- **Control over the Name of the Layout file:**

You have full control over the output file name of the task [Create Nested Layouts](#) (this is not the case for the output of a GRP queue).

- **All in 1 workflow ticket:**

Unlike when you use the GRP mode, this workflow is not split into 3 parts. In this mode, the nesting calculation itself is just one step in a workflow ticket. This workflow can of course start with tasks that prepare the one-ups and can end with sending the layout to the device.



**Tip:** When you do not have the right XML to feed the [Create Nested Layouts](#) task, you can use the task [Add Parameters for Nesting](#) to create it.

We also advise to check if the GRP mode is a better alternative.



**Note:** Apart from the above mentioned tools in Automation Engine, there is also the Esko editor **i-cut Layout**, where you can create nesting / gang run layouts in a semi-manual way. You first select and prepare each graphic individually, then you request the application to calculate and propose you the most efficient layouts. As you see them before you, you can still tweak the results if necessary. Learn more in the [i-cut Layout manual](#).

### Overview of Sign & Display related Tasks

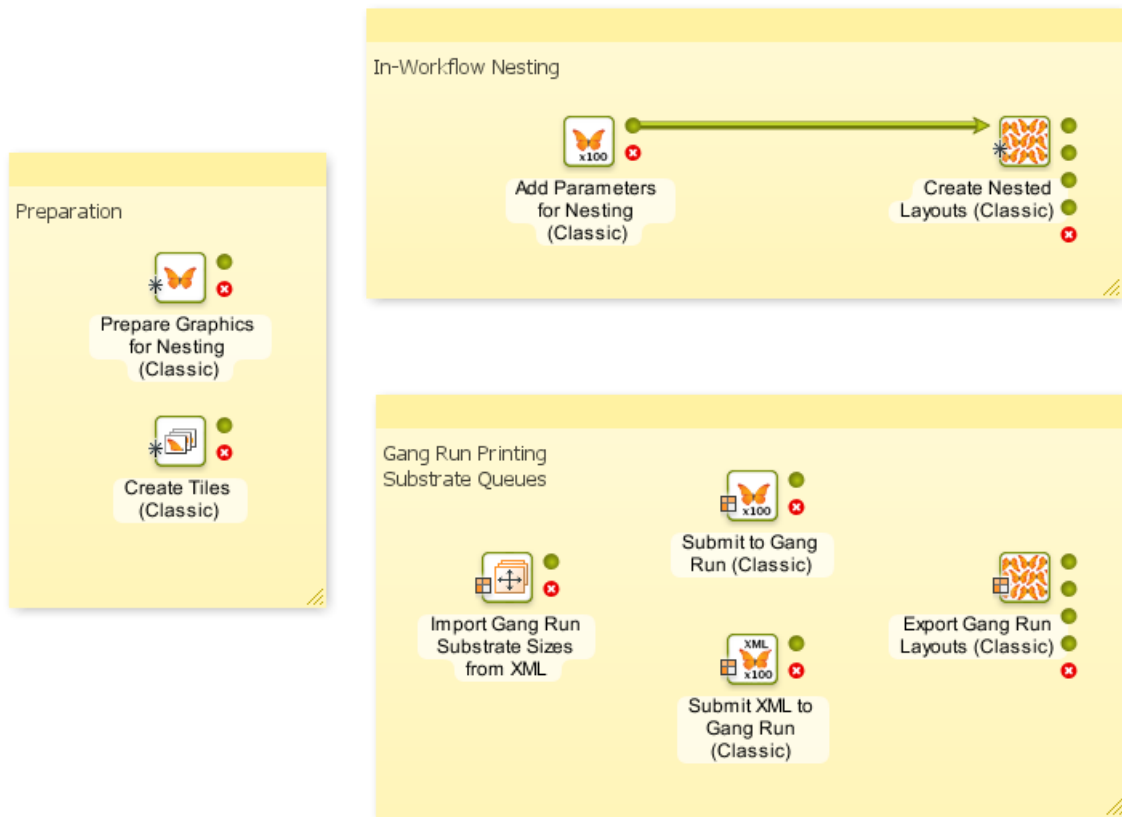

## 14.3. Preparation Tasks

### 14.3.1. Prepare Graphics for Nesting (Classic)

Use this task to *prepare* individual graphics for being added to a layout. You can create a cut path, extend the graphics and add SmartMarks.

This task supports these input file types:

- PDF (single page or multi-page),
- Normalized PDF (single page or multi-page).
- TIFF (CMYK or grayscale),
- JPEG (CMYK or grayscale. Progressive JPEG compression is not supported.),
- PSD (CMYK or grayscale),

You can use this task in both '*nesting*' modes:





- Use this task as main tool in your *input workflow*, before the *Submit to Gang Run* task. The input workflow prepares the graphics and submits them to a *substrate queue* on the nesting server (see

[Working with Gang Run Printing Substrate Queues](#) on page 977 for an overview of the whole Gang Run Printing process).

- You can also use this task to prepare graphics in a [workflow where the nesting is done by a task](#).

### Create Cut Path From

In **Create Cut Path from**, define what to use as a cut path and how to generate one.

If you want to...	do the following...
use an <b>Ink</b> as cut path	<p>1. Select <b>Ink</b>.</p> <div data-bbox="651 645 1423 725" style="border: 1px solid #ccc; padding: 5px;">  <b>Note:</b> Only objects with a 100% fill or stroke of this ink are taken into account to make the cut paths.         </div> <p>2. Enter the name of the ink to use in the field below.</p> <div data-bbox="651 779 1423 1234" style="border: 1px solid #ccc; padding: 5px;">  <b>Tip:</b> <ul style="list-style-type: none"> <li>If the ink to be used for the cut path has different names in different input files (for example if you have customers using names in different languages like <i>cut</i>, <i>découpe</i>, <i>taglio</i>...), you can add several ink names, separated by a comma ( , ).</li> </ul> <p>Their order is important: The task will use the first ink it finds in the list as cut path!</p> <ul style="list-style-type: none"> <li>You can use wildcards and/or SmartNames to define ink names. For example use <i>Pantone*</i> if you want to use any Pantone ink used in the file as a cut path.</li> </ul> </div> <div data-bbox="651 1249 1423 1442" style="border: 1px solid #ccc; padding: 5px;">  <b>Tip:</b> When building a workflow using an example file, click  to select one or more of the inks from the example file.</div> <p>If you always receive CMYK graphics with one spot color used for the cut path, select <b>ANY SPOTCOLOR</b>.</p> <p>3. Define what to do if the ink(s) you defined are <b>not found</b> in the file:</p> <ul style="list-style-type: none"> <li>If you want to use the trim box as cut path instead, select <b>Create cut path from trim box</b>.</li> <li>If you want the task to end in error, select <b>Generate an error</b>.</li> </ul>
use the <b>Trim Box</b> as cut path	Select <b>Trim Box</b> .
use the cut path defined in an external ARD, PDF or Normalized PDF <b>File</b>	Select <b>File</b> and <b>Browse</b> to that file (or use SmartNames to define the path to the file).
create a cut path from the contour of the graphic on its <b>White Background</b>	Select <b>White Background</b> .

If you want to...	do the following...
	 <p><b>Note:</b> This will include both the contour of the design on the white background and the contours of any "white holes" in the design in the cut path. You can then remove the "white holes" contours using the <a href="#">Remove holes</a> option.</p>

### Optimize Cut Path

This **Optimize...** dialog offers ways to optimize the shape of your cut path.



**Important:** Especially when you created the cut path with the [From White Background](#) method, you typically need to optimize the automatically generated cut path contours to facilitate and speed up the cutting process.

You can:

- **Remove holes** in your cut path.

Select this if the cut path was extracted from a white background and your graphic contains white. This option makes sure that the white parts in your graphic are not considered part of the background (which would create holes in your graphic).

- Smooth small jagged edges in your cut path.

Select **Smooth cut path** and enter the desired minimum distance. Any point that deviates from the cut path by less than that distance will be smoothed.

- Remove small objects from your cut path.

Select **Remove small contours** and enter the minimum contour size. Any objects smaller than this will be removed from the cut path.

- Move the cut path inwards or outwards.

Select **Offset cut path** and enter a positive offset value (to move it outwards) or a negative one (to move it inwards).

- Make **Round corners**.

Both inside and outside corners will get rounded with the defined **Radius**.

This is especially advised to shorten the production time on a cutting table. Also when the cut path serves to help peel off self-adhesive labels from a matrix.



**Note:** A corner needs to be formed by one same line. This option does not work when the corner is formed out of two different lines.

### Cut Path's Ink Name

In **Cut Path's Ink Name**, enter the ink name to use for the cut path you just defined.

- If you defined the cut path based on an ink in your file, this will rename that ink to the name you enter here.



**Note:** Only objects with a 100% fill or stroke of this ink are taken into account to make the cut paths.





**Tip:** Use this to standardize cut path ink names across files (especially when your files come from different customers).

- If you defined the cut path from the file's trim box, white background, or an external file, this will add the cut path in that ink in your graphic file.

The cut path ink name you enter here will later in the *input workflow* be used to identify the cut path in the *Submit to Gang Run* task.

## Extend Graphics

If you want to extend the graphics, choose one of these modes:

### Create Bleed

If the graphic contains no bleed, you can add some here. Select **Create Bleed** and choose from these **Options**:

- the **Bleed Distance** (the distance outside the cut path).
- the **Bleed Type**. You can choose between:
  - Choose **Clone** to take the part of the graphic just inside the cut path and clone it to the outside of the cut path.



- **Clone From:** choose the distance on the inside of the cut path from which data will be cloned. This is useful in cases where graphic elements are very close to the cut but are not required to bleed out. This can avoid unwanted effects. An example:

OK. "Clone From" distance was small enough.



Not OK. "Clone From" distance included black pixels from the text.



This option works on cut paths with any shape (free form or rectangular).



**Note:** When an RGB image is cloned, the cloned bleed will contain CMYK information. The image data within the cut path remains unchanged.

- Choose **Mirror** to take part of the graphic (as much as the bleed distance) and mirror it to the outside of the cut path. This option is only useful on rectangular cut paths.

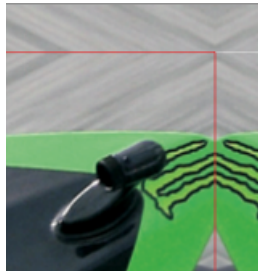

The visual effect is less distracting and is advised with large bleeds or when the bleed remains visible (as in below example of a photo canvas).

### Extend Content

This mode mirrors the graphic content over the 4 sides and corners of the original cut path, and extends the cut path. This can be used to create a hem for a flag, banner or canvas.

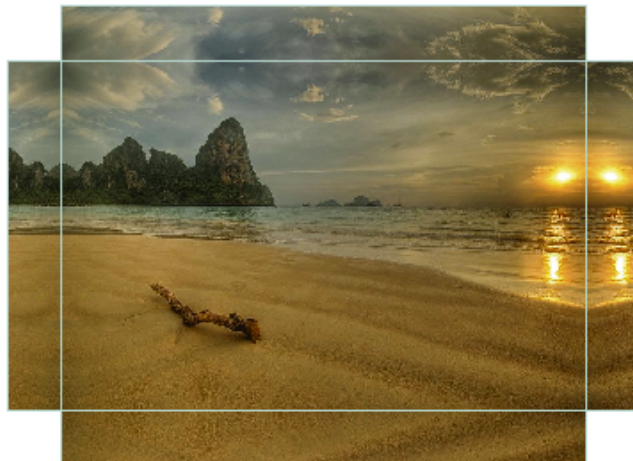

In the **Options**,

- Set the **Hem Size**, defining how much the cut path needs to be extended.
- Define the shape for the **Corner**: square, round, bevel or cut-out. Use **Edit...** to control the shape with a SmartName. Learn more about using SmartNames for buttons in [SmartNames of Parameter Values](#) on page 729.
- For round and beveled corner shapes you can supply a **Bevel Distance**.
- In **Limit Bleed**, you can add bleed on the extended cut path. As the hems are created by mirroring the graphics, the bleed will also make use of those mirrored graphics.

### Use backside graphic



In this case the graphic is extended with content taken from the backside graphic. This is useful when producing banners that have a printed front and back.

Its **Options** are identical as mentioned above in **Extend Content**, except for these that are specific for this method:

- **Backside Graphic:**
  - **Even Pages:** Select this when the backside of the graphic is the even page of the multi-page PDF that was selected as input file for this task.
  - **File:** Select this to indicate a separate PDF that will serve as backside graphic in the production process.
  - **Glue area:** This area will knock out the graphics on the back side, so creating a non-printed area where glue will be applied.

An example result:

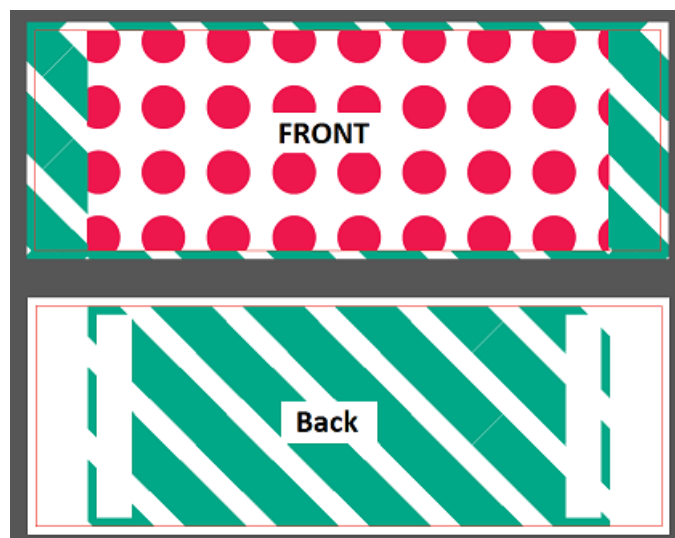

### Use solid color

In this case the graphic is extended with a solid color. This might be useful when the graphic also ends in a solid color (on all 4 sides).

Its **Options** are identical as mentioned above in **Extend Content**, except for this one that is specific for this method:

- **Solid Color:** Type in the values of **C**, **M**, **Y** and **K** that will define the solid color.

### SmartMarks

You can add **SmartMarks** to the resulting graphics (a SmartMarks set that you created in an Esko editor **i-cut Layout** or **PackEdge**).

For example, you can add a **Text on Cut Path** mark to automatically add the name of the graphics file and other info on the cut path, for example in the bleed zone. This information is then visible on the cutting table and so helps organize your printed graphics after cutting. An example:

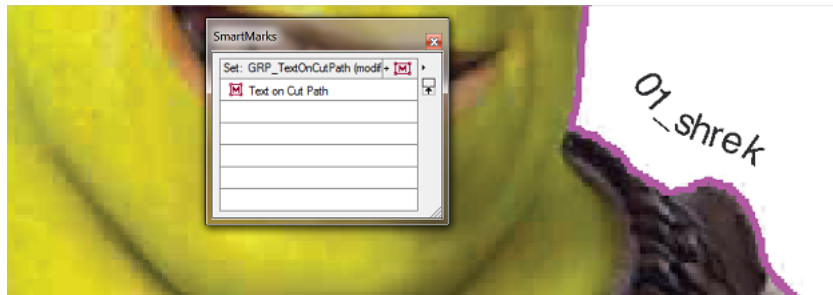

**Note:**

Before you can do this, you need to:

1. Make sure your i-cut Layout or PackEdge application is connected to your Automation Engine server.
2. Create and save a SmartMarks set in i-cut Layout or PackEdge (this automatically saves it to the correct location on your Automation Engine server: \\AEServername\bg\_data\_marks\_v010\dat).

See the *i-cut Layout* or *PackEdge manual* to learn more about connecting to an Automation Engine server and creating a SmartMarks set.

### 14.3.2. Create Tiles (Classic)

Use this task to tile oversize graphics into smaller graphics to be printed, a typical production workflow when creating billboards. You can select the size and number of the tiles, and allow for an overlap if necessary.

The task supports these input file types:

- PDF (single or multi-page),
- Normalized PDF (single or multi-page),
- TIFF (CMYK or grayscale), 8-bit TIFF also supported.
- JPEG (CMYK or grayscale. RGB JPEGs result in CMYK PDF. Progressive JPEG compression is not supported),
- PSD (CMYK or grayscale).



**Note:**

- For each image file or single page PDF, the task outputs a multi-page PDF in which each page contains a tile.
- For multi-page PDFs, the task outputs a multi-page PDF (in which each page contains a tile) for each page of the input multi-page PDF.

1. In **Method**, choose how to determine the number and size of the tiles:

- If the tile size is the most important (if for example you can only print a certain size), choose **Use Fixed Tile Size** and enter the horizontal ↔ and vertical ⇅ **Tile Size**.



**Note:** The last tiles might be smaller (depending on the tile size and the size of the original file).

Select **Allow Rotation** if you don't mind having the graphic rotated by 90 degrees in case this fits better and generates less tiles.

- If the number of tiles is more important to you than their size, choose **Use Grid** and enter the **Number of Tiles** you want horizontally and vertically .
- If you don't know the exact number or size of the tiles you want, but you can only print up to a certain size, choose **Automatic Tiling** and enter the **Maximum Tile Size** horizontally and vertically .

The number and size of the tiles are calculated to have the least waste and the least tiles possible, within that maximum size.

All tiles will have the same size, except when adding an **overlap** (see below).

Select **Allow Rotation** if you don't mind having the graphic rotated by 90 degrees in case this fits better and generates less tiles.

- If you have a tiling template that you have created in **i-cut Layout** and want to use here, choose **Use Template** and select your template in the **Template** list.



**Note:**

To do this, you need to:

1. Make sure your i-cut Layout application is connected to your Automation Engine server.
2. Create and save the template in i-cut Layout (this automatically saves it to the correct location on your Automation Engine server: \\AEServername\bg\_data\_custom\_v010\dat\tiling).

See the [i-cut Layout manual](#) for more information about connecting to an Automation Engine server and creating a tiling template.

With a tiling template:

- you can see exactly how your graphic will be tiled when creating the template in i-cut Layout (if you create the template from the same/a similar graphic that you will use in Automation Engine),
- you make sure you have consistent tiling in i-cut Layout and Automation Engine (for example if you use i-cut Layout for one type of job orders and Automation Engine for others).







**Attention:** If you want to add overlaps to your tiles when using a template, you need to already add them in the template in i-cut Layout. You cannot add overlaps to tiles created from a template in this **Create Tiles** task.

If you enable **Fit graphics to grid**, your graphic will be scaled to match the grid size, both vertically and horizontally. This can result in non-proportional scaling!

- **Irregular Shape Tiling:** This method gets the tile elements based on the closed paths found in the cut path separation on board the input graphic. This creates a similar result as jigsaw tiling in [i-cut Layout](#).

The cut path separation is examined for closed curves. Each closed curve will be used as cut path of one separate tile. Closed inner contours will not lead to separate tiles (instead they will act as 'holes' in the tiles' cut path).

2. Open **Tiling Sequence...** to define the sequence of the tiles (not available when you use a template).

a) In **Tile Start Position**, select where you want the first overlap to be: on the top left , top right , bottom left  or bottom right  tile.



**Note:**

You can use SmartNames for most options of this dialog. For button options like **Tile Start Position**, **Direction** and **Pattern**, you can set a SmartName by clicking , and edit it by clicking **Edit...**



**Tip:**



To know what the SmartName should resolve to to get a certain value for a parameter, do the following:





1. Right-click the parameter value and select **Copy Parameter Value**.

- For a parameter with a field to edit (like **Overlap**), enter the desired value in the field then right-click in that field.
- For a parameter with buttons (like **Tile Start Position**), right-click the button of your choice.

2. Paste this in a text editor.



For example, the SmartName to get a top left  **Tile Start Position** should resolve to t1.

b) In **Direction**, select whether the overlaps should run horizontally  or vertically .

Depending on the **Tile Start Position** you chose, horizontal overlaps can run from left to right  or from right to left , and vertical overlaps can run from top to bottom  or from bottom to top .

c) In **Pattern**, choose whether you want the overlaps to run snake-wise  or in zig-zag .

The exact snake-wise or zig-zag pattern depends on what **Tile Start Position** and **Direction** you selected.

For example, when starting on the top left tile  and running horizontally  with a snake-wise pattern , you will get something like this:



We advise that you run a test to determine exactly what pattern works best for your graphic.



**Note:** When using overlaps, the direction is often decided by physical laws like the direction of rain and wind.



**Note:** When using a vertical snake direction, the tiles in the uneven columns will be rotated 180 degrees. This is done to optimize color consistency between rows when printing on large printers. You can see this rotation in their page in the output multi-page PDF and also in the tiling report. See this illustration where 2 columns of tiles will be created with a 180 degree rotation:

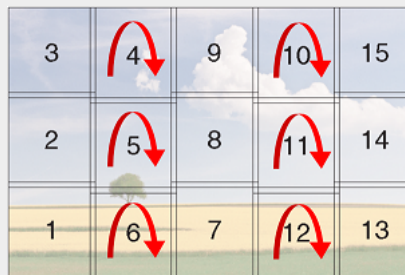

**3. Define what to use as Cut Path.**



**Note:** Whereas the *Prepare Graphics for Nesting* task allows you to generate a cut path if the graphic doesn't contain one, the **Create Tiles** task needs the cut path to be already available, either as an ink or by using the trim box as cut path.



**Note:** The task actually checks this information first because it is the cut path that decides the size of the input graphic that should be tiled. This overall size then influences the required number of tiles (unless you set a fix number).

If you want to...	do the following...
use an ink as cut path	<b>1.</b> Enter it in the <b>Cut Path</b> field.

If you want to...	do the following...
	<div data-bbox="676 322 738 380" style="float: left; margin-right: 10px;"></div> <p><b>Tip:</b></p> <ul style="list-style-type: none"> <li>If the ink used for the cut path has different names in different input files (for example if you have customers from different countries using names like <i>cut</i>, <i>découpe</i>, <i>taglio</i>...), you can add several ink names, separated by a comma ( , ).  The order you use is important as the task will use the first ink it finds in the list as cut path!</li> <li>You can use wildcards and/or use SmartNames to define ink names. For example use <code>Pantone*</code> if you want to use any Pantone ink used in the file as a cut path.</li> </ul> <hr/> <div data-bbox="676 855 738 913" style="float: left; margin-right: 10px;"></div> <p><b>Tip:</b></p> <p>When building a workflow using an example file, click  to select one or more of the inks from the example file.</p> <p>If you always receive CMYK graphics with one spot color used for the cut path, select <b>Any SpotColor</b>.</p> <p><b>2.</b> Define what to do if the ink(s) you defined are not present in the file:</p> <ul style="list-style-type: none"> <li>If you want to use the trim box as cut path instead, select <b>Create cut path from trim box if no ink is found</b>.</li> <li>If you don't want to use the trim box but want the task to end in error, leave <b>Create cut path from trim box if no ink is found</b> deselected.</li> </ul>
use the trim box as cut path	<p>Leave the <b>Cut Path</b> field empty.</p> <p>If you always want to use the trim box as cut path (usually for rectangular graphics like business cards), you don't need to select <b>Create cut path from trim box if no ink is found</b> (as this option is only applicable when you want an ink as cut path as your first choice).</p>

The task will tile the graphic that is inside the cut path. The tiles created will have a cut path in the same ink as the input graphic's cut path (if the cut path is created from the trim box, this will be the Cut ink).

- Graphics for large banners or billboards are often not supplied in the size at which they will be printed. In that case, you can **Scale** the tiles here.

For example, enter 1000% if your input graphic is only 10% of the size you will need it to be.

5. If the input file (the non-tiled full graphic) has a bleed, the resulting tiles will show that bleed on their outside sides (except those surrounded by other tiles). You can limit that bleed on the tiles by setting a maximum bleed in **Bleed Clipping Mask**.

See this example of a full graphic with a bleed. The trim box is shown in red. This graphic will be tiled in 4 tiles:



Here is the below left tile:



In this example the bleed of the full graphic is similar to tile's overlap. But sometimes this bleed can be too large for a tile. That is why you can reduce that original bleed by setting a **Bleed Clipping Mask** on tile level.



**Note:** In i-cut Layout, in the **Tiling** dialog, this same function is named **Tile Bleed**.

6. If you want, you can add **SmartMarks** to the tiles. SmartMarks sets can be created in i-cut Layout or PackEdge. We advise to create them in i-cut Layout because it offers extra SmartMarks fields that are specific for tiling.

You can for example add SmartMarks containing glueing instructions in the overlap zones. [Below page](#) illustrates a typical example.

7. If you want to include overlaps (we mentioned a few types when introducing [Tiling](#) on page 954), select **Add Overlap** and click **Options...**
  - a) Enter the **Overlap Distance**.
  - b) You can choose to add an **Overlap on both sides** of each tile (using the overlap distance on both sides).

In this case, you can not add a glue area.

- c) If you want, also add a **Glue Area**.

This is an extra area that is not printed:



- d) Click **OK**.



**Attention:** Adding overlaps and glue areas increases the size of a tile (except if it is the last one on the grid). If you selected the tiling method **Use Fixed Tile Size** or **Automatic Tiling**, you should take these extra distances into account.

- 8. If you want a report detailing how the graphic was tiled, select **Create tiling report** and click the **Options...** button to define some options like the report **Size** and the used **Units**.

See (part of) an example of a report in below described example.

### Example of SmartMarks for Tiles

#### Concept

This page shows how to add specific tiling related information into the glue or overlap areas of a tile. A typical example is to put the number of the neighbouring tile in this area. This helps those who apply the tiles.

See this (first page of a) tiling report where we added red squares to help you recognize the SmartMarks we added:



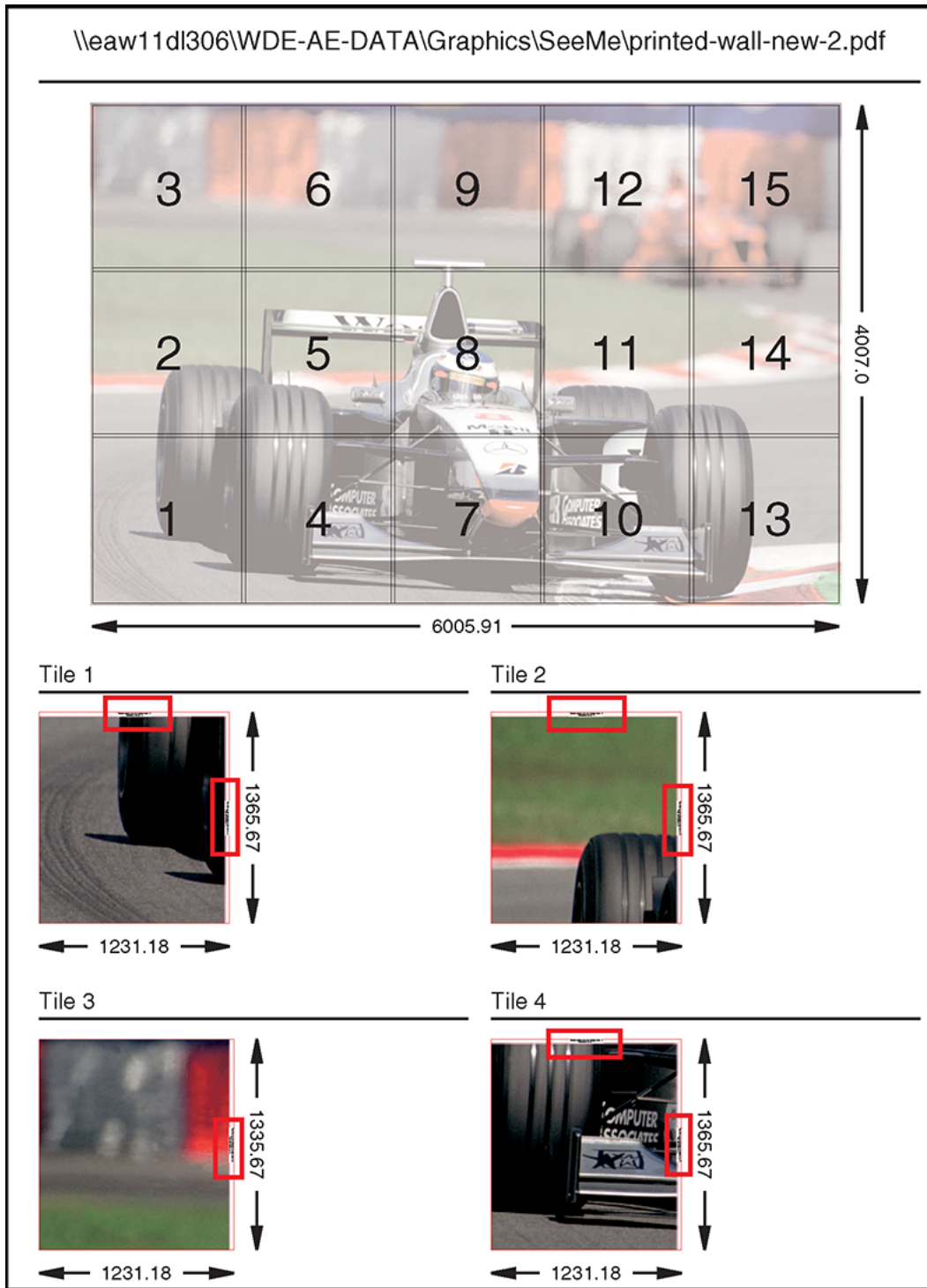

Notice that tile nr. 3 only has these marks in its glue area on the right. This is because the SmartMarks know that this tile has no glue area on any other side.

The next image zooms in on this mark (a view from I-cut Layout or PackEdge), both in contour and preview mode. It shows an overlap of 10 mm and a glue area of 20 mm. Notice that the text appears mainly in the glue area, but also partially in the overlap. And to make sure it can always be read, a white rectangle is placed behind the text area:

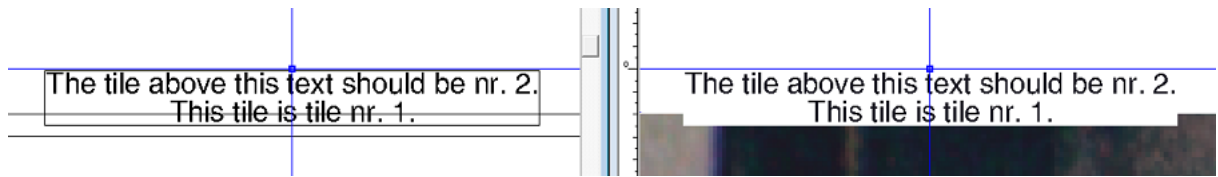



### How to Create this SmartMark Set



**Note:** In below instructions, we assume you have basic knowledge of both i-cut Layout and SmartMarks.

Follow below steps to create a set of SmartMarks as shown above.

1. You can use any of your files that may need tiling. Choose one and write down its size (V-H).
2. In i-cut Layout, create a **New** layout. Set the height and width to that of the file you choose to use. In our example we will create a layout of 4000 mm by 6000 mm. The name or place is not important. Click **OK**.
3. In **Graphics** mode, click on  to **Add a Graphic**. Select the file you chose in step1 and click **OK**.
4. In the list of **Graphics**, double click the thumbnail of the graphic.
5. While in **Graphic View** () , choose **Tools > Tiling**.
6. In the **Create Tiling Grid** dialog, specify a number of tiles: set 3 vertical and 3 horizontal and click **OK**.
7. In the **Tiling** dialog, select **Include Overlaps** and click on **Set Up Overlaps....** Set an **Overlap** of 10 mm, deselect **Overlap on both sides** and set a glue area of 20 mm. Set a **Tile Bleed** of 3 mm (though we will not use this in the SmartMark). Keep the dialog open.
8. Select a tile that is surrounded by other tiles on all 4 sides. The **Tiling** dialog shows the settings for this tile:

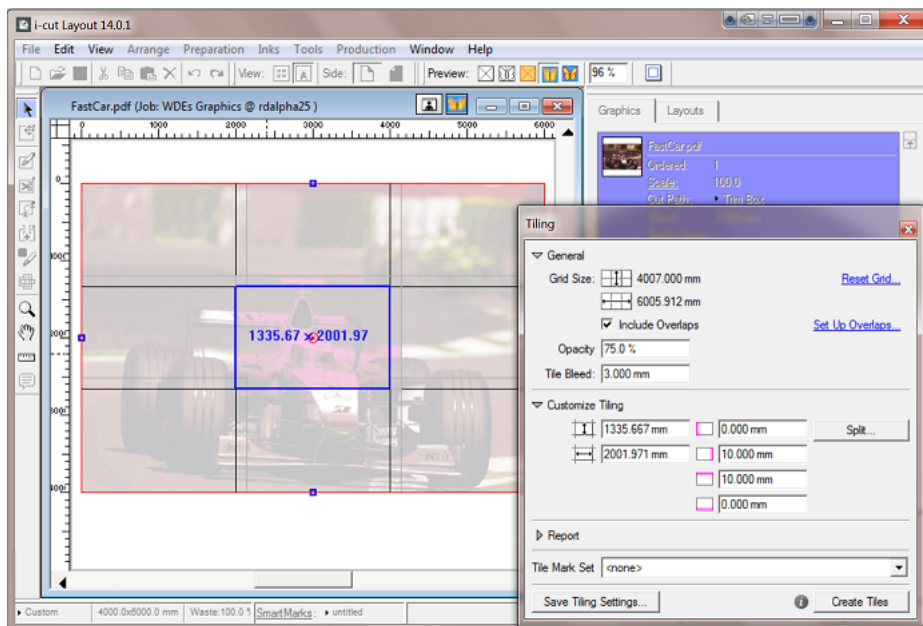

The SmartMark set that we will make needs to add marks on every overlap that the tile has, no matter what tile it is, so no matter of that tile has overlaps on one or two or more sides. To do this, we need to simulate a tile that has an overlap on all 4 sides.

9. Select the central tile (tile 5). In the **Tiling** dialog, make sure all 4 sides have an overlap. Based on above example, you therefore need to manually add a 10 mm overlap to also the left and bottom side:

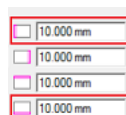

We can now use this tile 5 to create our SmartMark set.

10. In the **Tiling** dialog, click on **Create Tiles**. The 9 tiles are created and added to the list of **Graphics**.
11. In the list of **Graphics**, scroll down to tile 5 and double click its thumbnail to open it. Then go to **Production > SmartMarks**. See how the **SmartMarks** dialog already shows many **named objects**, including 4 **Overlap** and 4 **Glue** objects.

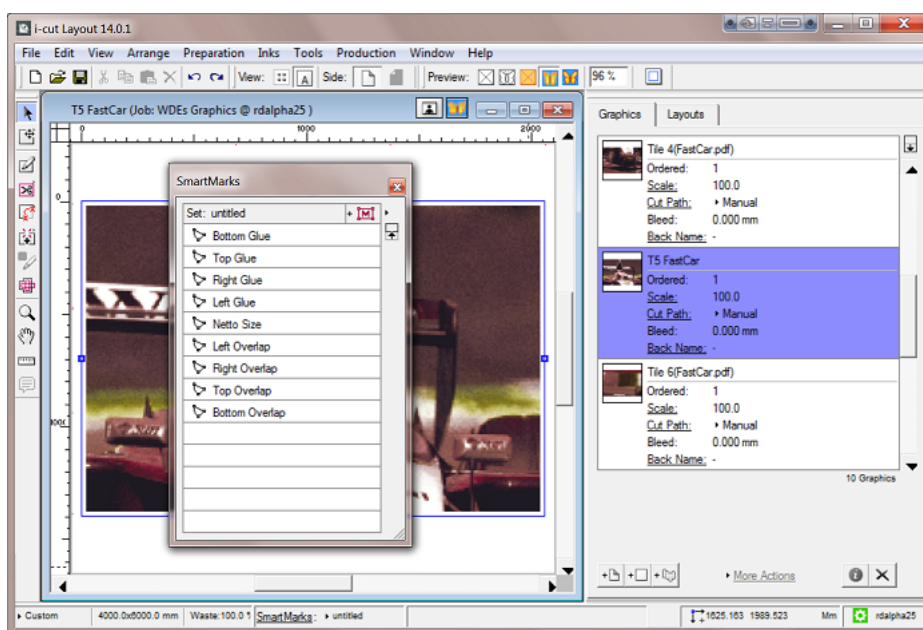

12. We now start adding the marks. We start with the one on the right side, though the order is not important. In the **SmartMarks** dialog, select the named object **Right Overlap**, then click on **+ [M]** and choose to add a **Text Mark**.



**Note:** In this example, we will position the text inside the overlap area. You can also put it in the glue area, but often users avoid any printing the glue area.

13. In the **Text Mark** dialog,
  - As **Text:** keep **Automatic Size** selected and add the text as shown below. To insert the smart text fields, click on **Smart Text**, scroll down to the category **i-cut layout**, choose **tiling** and in **Options**, choose to insert (in two times) [Right Tile] and [Current Tile number].

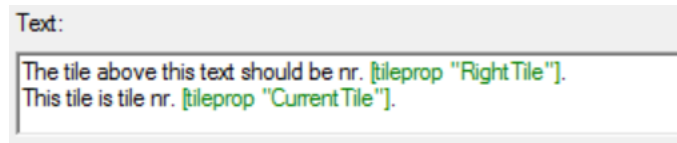

Click on **Style**, set the font size to 36 and align the text centered (H & V).



**Note:** This font size may be too large when you create tiles with smaller glue areas. This could cause the text to enter in the tile area itself. To avoid this, choose **Smart Text** and in the category **Typographic** choose **Automatic Point Size** and set a minimum and maximum size.

- In **Inks**, choose **Darkest** to avoid too much ink in this glue area. Also select **Ignore Technical Inks**.
- In **Position**, attach this text mark to the **Right Overlap**. Position it as shown below. Add a small offset versus the (left) end of the overlap area. Make sure you rotate the text 90 degrees.

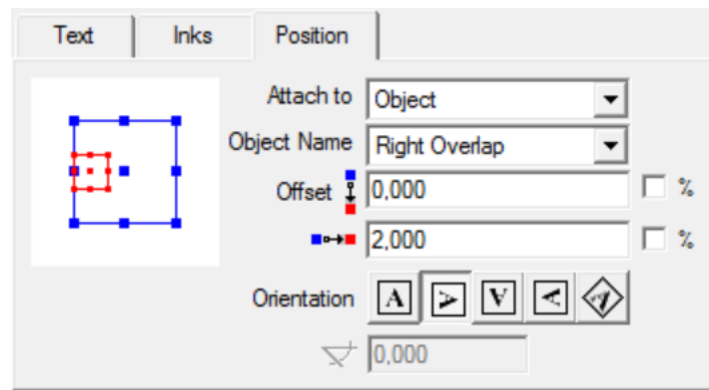

Click **Apply**.

14. As good practice, rename the text mark to a logical name like "Text Mark - Name of Right Tile". To do this, select the text mark, then right-click it to enable renaming it.
15. Now add a white rectangle below this text box. Add the mark of category **rectangle** and manually drag and drop it onto the text mark. It should appear as shown here:

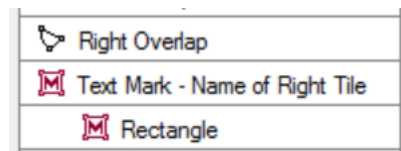

In the **SmartMark Options - Rectangle** dialog:

- in the **Rectangle** tab: select **Fit (to object)** to create a rectangle that adapts to the text box (both V and H). Set an **Extra Height and Width** of 1 mm.
- in the **Inks** tab, select **Knockout**.
- in the **Position** tab, position the rectangle central versus the text mark **object**.

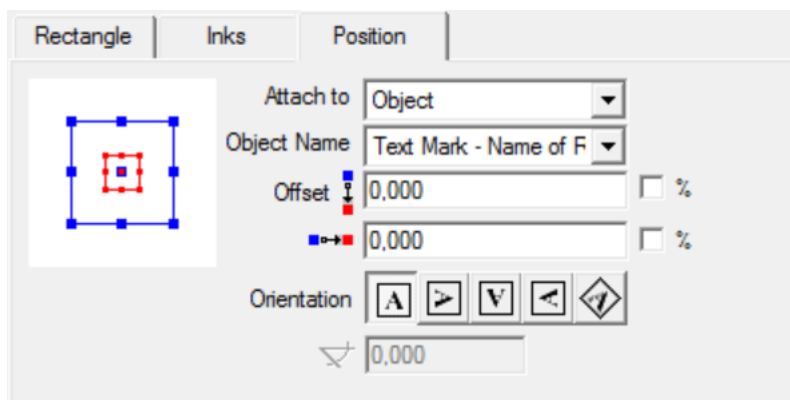

Click **Apply**.

16. Save your SmartMarks set with a logical name.
17. Now repeat the above steps 11 to 14 for the 3 other sides.
18. Save your SmartMarks set again (and close i-cut Layout).
19. In Automation Engine Pilot, test this SmartMarks set by using it in the **Create Tiles** task.

## 14.4. In-Workflow Nesting Tasks

### 14.4.1. Add Parameters for Nesting (Classic)

Use this task to specify nesting parameters for a particular graphic (cut path, quantity needed, due date...).

If you want to combine different graphics onto a sheet, you should send them all as input files to the same **Add Parameters for Nesting (Classic)** task.

You can send PDF (single or multi-page), TIFF, PSD or JPEG files to this task. Progressive JPEG compression is not supported.

It outputs an XML file containing all of the nesting parameters for the graphic(s). You can then send that XML file to the [Create Nested Layouts](#) task.



**Note:** You can use SmartNames to retrieve the parameters needed from the Job setup.

1. In the **Front** tab, specify the **Quantity** of that graphic that you want to print.  
You can select **Maximum Fill** if you want to print as many copies as will fit in one sheet (if you are not sure how many copies fit exactly and you don't want to waste paper).
2. If the input file is a downscaled version of your graphic, enter the **Scale** to use.  
For example, enter 1000% to compensate a graphic that was downscaled to 10%.
3. If the graphics in your files have a bleed outside the cut path, you can clip it away by entering the bleed distance into **Bleed Clipping Mask**.

4. Enter/choose the ink used for the cut path in the **Cut path** table (the drop-down list will contain all inks used in the input file).

You can **Add** several inks (for example if you have customers from different countries using different ink names like *cut*, *découpe*, *taglio*...) and **Move** them **Up** or **Down** the list. The order is important as the task will use the first ink it finds in the list.



**Note:** If you have specified a cut path ink name in the **Prepare Graphics for Nesting** task, you only need to enter that one ink name.

You can use SmartNames to retrieve ink names from the job setup.

Select **Create cut path from trim box if no ink is found** if you want to use the trim box to create a cut path when a file doesn't contain any of the inks you specified.

5. Specify a **Due Date** for the nesting (when the sheet with the nested graphics needs to be printed).
6. In the **Back** tab, you can specify what to print on the back of each repetition of the graphic:
  - **No graphics.**
  - **Even pages of multi-page file:** if you choose this, the odd pages of the file will be printed on the front, and the even pages on the back (this only works with multi-page PDFs).
  - **Graphics from front side:** choose this if you want to print the same graphic on the front and on the back.

If your graphic has an irregular shape, you can select **Flip horizontally** so both graphics face the same direction and have the exact same contour for cutting.

If your graphic contains text, you shouldn't flip it as this will make the text unreadable.

- **Other graphics:** you can **Browse** to the graphic you would like to print on the back side.



**Tip:** Give the graphics to print on the back a consistent name, and use SmartNames to retrieve them (for example, `[File]_back.[Extension of File]`).

## 14.4.2. Create Nested Layouts (Classic)

Use this task to nest a set of graphics onto one or more sheet layouts, and create production files (a PDF print file and a cutting file) for digital printing and finishing.

Send the XML files generated by the [Add Parameters for Nesting task](#) to this task. You don't need to send the graphics as each XML file contains a link to the related graphic.

You can also use (compatible) XML files produced by an MIS system.

Alternatively, you can send already stepped and repeated (PDFPLA) files to this task to generate production files. This will then skip the nesting part and only output a print file and a cutting file.



**Note:** You can use SmartNames to retrieve the parameters needed from the Job setup.



**Note:** In a workflow, this task has four output pins (**Print Files**, **Cutting Files**, **Done Graphics** and **Remaining Graphics**), so you can easily send each type of file to the right place or to its own continued workflow.

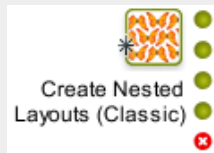

If you select **Create report**, the task will have a 5th output pin for the report.

## 14.5. Working with Gang Run Printing Substrate Queues

The rest of this chapter is about the Pilot's view named **Gang Run Printing** (in the view Category 'Sign & Display').

Here is an overview of how you can work with the Pilot's Gang Run Printing mode.

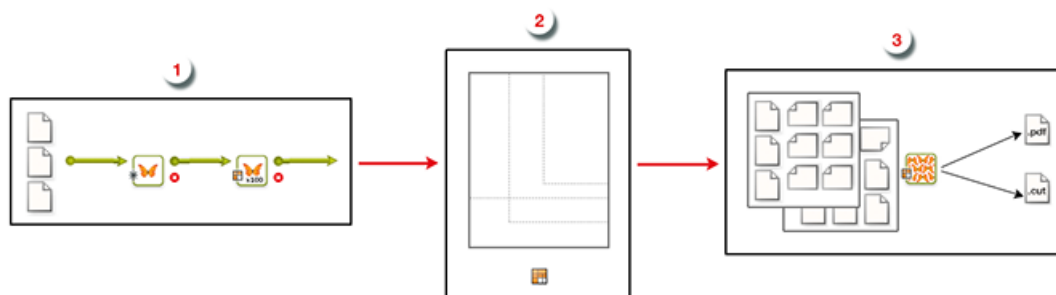

1. You first **prepare** your graphics and **submit** them to be nested on a particular substrate, in your chosen quantity.

You do this through an **input** workflow, that should contain the **Prepare Graphics for Nesting (Classic)** task and ends with the **Submit to Gang Run (Classic)** task.

Learn more in [Preparing and Submitting your Graphics \(Input Workflow\)](#) on page 978.

Optionally, you can include the [Create Tiles](#) task to split the prepared graphics into smaller tiles before submitting them.

2. Once the graphics are submitted, they go in a **substrate queue** and the **nesting server** calculates the best possible **nested layouts**, based on the **sheet or roll sizes** and their **nesting settings**. All this is set up and can be monitored in the Pilot's Gang Run Printing view.

Learn more in [Creating Gang Run Layouts on the Nesting Server](#) on page 980.

3. Once the nesting server has decided one or more **optimal nested layouts**, it delivers them to your **output workflow**, that creates **production files**: layout PDF(s), cut file(s) and report(s).

The output workflow must start with the task **Export Gang Run Layouts (Classic)**. You could for example continue this workflow with steps that copy the production files to a specific folder where they are picked up by the press.



Learn more in [Getting Production Files out of your Gang Run Layout\(s\)\(Output Workflow\)](#) on page 984.

### 14.5.1. Preparing and Submitting your Graphics (Input Workflow)



#### Preparing your Graphics

The nesting is based on the graphic's **cut path**, so before you submit graphics to a substrate queue you need to make sure they have a cut path. You may also want to add **bleed** and **SmartMarks**. This is what the **Prepare Graphics for Nesting** task is for.

Learn more about the task's options in [Prepare Graphics for Nesting \(Classic\)](#) on page 958.

#### Identifying or Extracting a Cut Path

As mentioned, the cut path defines how graphics can be nested.

For example, cardboard cut-outs of a tree (as below left) will be nested and cut differently than postcards of a tree (as below right). Depending on the case, your tree graphic will need a different cut path (shown in red).



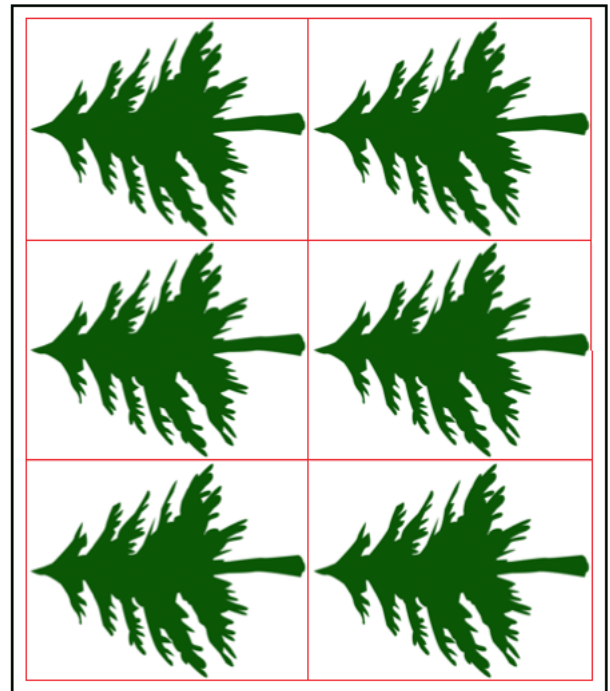
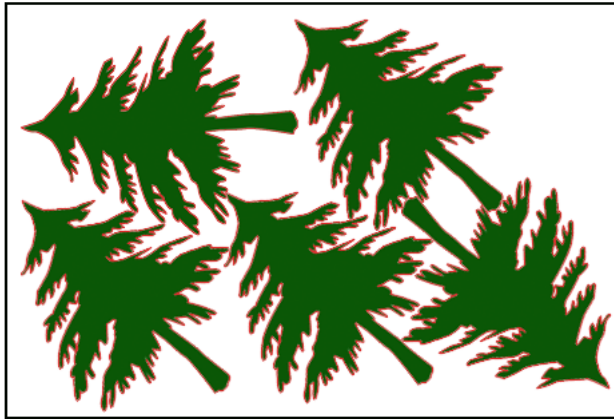

The cut path is typically provided in the file as a contour line in a spot color.

For graphics that don't already contain a cut path, you can generate one from the white background, the trim box, or use a separate file.

### Adding Bleed

If your file doesn't already have bleed outside the cut path or trim box, you can generate some using the Prepare Graphics for Nesting task.

### Adding SmartMarks

SmartMarks are marks that automatically update based on changes to the sheet size, the number of inks on the sheet, etc. You can use them as regular marks or as production controls. There are many types of SmartMarks: registration marks, barcodes, text, placeholders for eyelets, etc.

You typically add SmartMarks to your nested layout in your [output workflow](#) (mostly for cutting the sheet), but in some cases you need to add some SmartMarks to your graphic in your input workflow.

For example:

- You can add eyelet marks to a graphic that will be used for a large eyeleted banner. You need to add the eyelet marks before [tiling the graphic](#) to fit the substrate.
- When defining the cut path in the input workflow, you can add text on this cut path for easy processing after cutting (for example to indicate the job-order and customer reference, or the order the tiles must be glued in...).

### Tiling Oversize Graphics

When the final printed object is too big to fit on your largest substrate size (for example when printing billboards), you can split the graphic into rectangular tiles (fitting the substrate size) that can later be glued back together.

You can do this with the [Create Tiles \(Classic\)](#) task. This task allows adding overlaps to be able to glue the tiles on top of each other.

### Submitting your Graphics

Once your graphics *are ready*, you can send them to the 'nesting server' using the [Submit to Gang Run](#) task.



**Note:** This task also allows to submit ARD file (CAD) files to be nested on a layout.

The most important things to define in this task are:

- how many copies you want of that graphic,
- on which substrate you want it printed (and optionally on which substrate size),
- if you have a specific due date to get that graphic printed.



**Note:** Substrates are organized into substrate queues, which not only define the substrate to use but also how its entries will be nested.

Learn more in [Working with Substrate Queues](#) on page 981.

## 14.5.2. Creating Gang Run Layouts on the Nesting Server

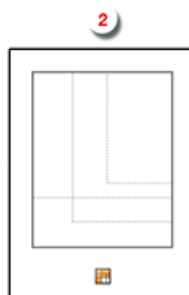

### Automatic Calculation of Layouts

Once your graphic(s) arrive in the [substrate queue](#), the nesting server calculates possible layouts to nest those graphics, together with any graphic(s) already in the queue.

The nesting server tries to find the most optimal layout(s) possible, based on these settings:

- the [nesting settings](#) you set up,
- the different possible **substrate sizes** (if applicable),
- the **minimum fill** percentage for that substrate queue,
- the use of any **grouping keys** (custom labels added to graphics when you submit them, to control the grouping of graphics for nesting).

When the minimum fill is reached, the nesting server sends the layout(s) to the output workflow to generate production files. All graphics that have been nested in these layouts are then removed from the substrate queue.

When the minimum fill is not yet reached, the graphics stay in the substrate queue until new graphics are submitted to the queue, at which point the nesting server calculates possible layouts again.

### Outputting a Partial Quantity of a Print Order

Sometimes the nesting server cannot fit all of the ordered copies of a graphic on layout(s) that satisfy the substrate queue settings.

In this case, rather than generating an extra layout with the remaining copies, the nesting server only outputs the quantity that does fit on the optimal layouts.

For example, if 10 copies of a graphic are ordered but only 8 fit on a layout satisfying the minimum fill, the nesting server does not generate a layout with only the remaining 2 copies. These 2 will stay in the substrate queue.

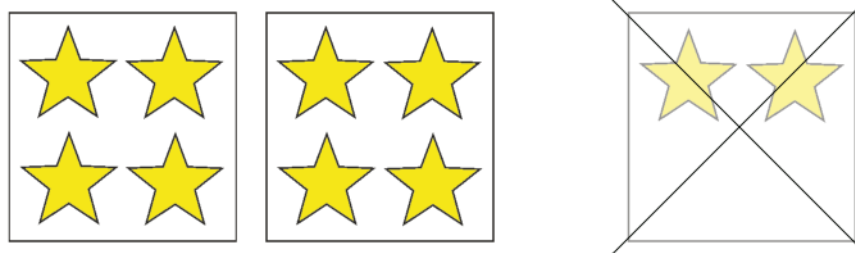

Once new graphics are submitted to that queue, the nesting server will again try to generate a nested layout with those remaining 2 copies and the new incoming graphics.



### When Time becomes More Important Than the Minimum Fill

As your customers expect their printed goods to be delivered by a certain date and time, sometimes you cannot wait for the minimum fill to be reached. In this case, you can either:

- manually force a layout to be generated from the remaining urgent graphics,
- enter a due date when submitting these graphics. The graphics will then be force-nested in time for that due date.

In both cases the nesting server generates a layout ignoring the minimum fill. However, it may also use other graphics from the queue in the layout to still raise the substrate's fill percentage.

### Working with Substrate Queues

A substrate queue acts like a printer queue to which you can send files you want to nest and print on a particular substrate.

### Substrate Queues Based on Material Types

For each type of substrate material you have in your stock (and still plan to use), you should have a substrate queue.

For example:

In your stock you have 2 piles of PVC substrates, one with thickness 3 mm and one with thickness 5 mm. For these you should set up 2 substrate queues with for example these names:

- PVC 3mm
- PVC 5mm

### Substrate Queues Based on Nesting Settings

It can also be useful to define substrate queues based on how the graphics will be nested and printed.

- If you have an expensive substrate, you can set the nesting server to always nest the graphics so that the substrate waste is minimal.
- If your graphics need to be nested on a material that will be printed in offset, you could aim for less plates (so less layouts) and accept the higher waste factor.

So if some graphics need to be nested differently (even if it is on the same material), you might need to create a different substrate queue for each type of printing/processing.

For example:

In your stock you have a pile of 250 g/m cardboard both for business cards and door hanger orders.

Business cards and door hangers will be cut differently:

- business cards will be cut by a paper guillotine,
- door hangers will be cut on a cutting table.

The way graphics are cut influences the way they need to be nested. Since nesting settings are attached to a substrate queue, you need different substrate queues.

In this case you should set up 2 substrate queues:

- Cardboard for Business Cards
- Cardboard for Door Hangers

### Grouping Certain Graphics Together

Even when graphics are to be printed on the same substrate or using the same printer, you may still want control with which other graphics they are nested. Using **grouping keys** allows you to do this without the need to set up separate substrate queues for this.

When [submitting the graphics](#), you can add grouping keys to help control which group of graphics can be considered to end up on the same layout. To the nesting server, these key words act like limitations in its freedom to decide nesting groups.

Even when submitting them to the same substrate queue, the nesting server will only nest graphics together that have the same value for a same grouping key.

Some examples:

- In your stock you have 1 pile of photo paper type "220 gsm". Depending on the order, some graphics printed on this paper need to be laminated, some don't. You can use a grouping key called "Lamination", with the values "Yes" or "No", to prevent laminated graphics being mixed with normal graphics.

In this case you only need to set up 1 substrate queue, for both regular and laminated graphics.

- A similar case is when you do not want to mix graphics that need varnishing with graphics that don't.
- Some customers do not want to mix graphics from different customers. In that case they use the customer ID as grouping key.



**Note:** Find a step by step example of a workflow using grouping keys [here](#).

## Substrate Sizes

If you have a substrate material in several sizes (sheet or roll), you can add these sizes to the substrate queue for that material.

For example:

In your stock you have 3 piles of substrates:

- 1 pile of cardboard 2000x1000mm
- 1 pile of cardboard 750x1200mm
- 1 pile of polystyrene 750x1200mm

For this stock you should set up 2 substrate queues:

- **Cardboard** (with 2 substrate sizes)
- **Polystyrene** (with 1 substrate size)

## Keeping Track of your Stock

### Keeping Track of Stock or Not

Per substrate size, you can decide to keep track of its stock. For sheets this is done in units and for rolls in length.

When you select this option for a substrate size, you first manually enter its current quantity. Then, every time the nesting server uses that size for a nested layout, it will be subtracted from the available quantity. In this workflow, Automation Engine will refuse to create a layout for a size that is out of stock.

When you choose to not have the Gang Run Printing mode keep track of your stock, the nesting server then always considers that substrate size 'available'.

Learn more about this setting in [Adding Sheet Sizes](#) or [Adding Roll Sizes](#).

### Substrate Offcuts

The nesting server always tries to create layouts with as little waste as possible. However, an approaching due date might force you to produce a sheet or roll that has a significant empty area that could actually be re-used.

Such rectangular left-overs are often called "offcuts". When the substrate is not that cheap, many users store those offcuts in stock and manually add them as a smaller sheet or roll size of that substrate queue, together with their current quantity.

Learn more about offcuts in [this page about nesting settings](#).

### Manual or Automatic way to Keep Track of Stock

- Manual means that a person checks your stock and manually types in those latest amounts directly in the Automation Engine Pilot, in the definition of each substrate size.
- Automatic means that a person checks your stock and manually types in those latest amounts in your stock management system, typically a part of your business system. This business system then updates Automation Engine by sending an XML that is picked up by the dedicated [Import Substrate Sizes from XML task](#).



**Note:** Learn more about using XML in [Automating your Workflow Using XML](#) on page 1043.

### 14.5.3. Getting Production Files out of your Gang Run Layout(s) (Output Workflow)

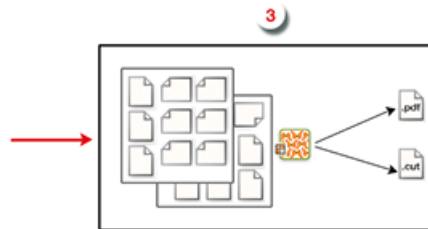

Every [substrate queue](#) is linked to an output workflow. You can build this workflow to your own needs, but it should at least contain the [Export Gang Run Layouts](#) task.

As soon as the nesting server has found one or more optimal nested layouts for your substrate queue, it delivers them to its output workflow, which is started automatically.

The output workflow then generates production files:

- A PDF file for the press, containing the nested layout including marks for printing and cutting, but without technical inks.
- A CUT file for the cutting table, containing the combined cut path of the nested graphics. You can choose from many different formats.
- (Optionally) a nesting report, in PDF format (which is useful for a cutting table operator) and/or in XML format (which is useful for a business system). Learn more in the [Export Gang Run Layouts task](#).

## 14.6. The Gang Run Printing View

The **Gang Run Printing** view is part of the category **Sign & Display**. It gives an overview of all graphics that have been submitted for nesting on each of the available substrate queues.

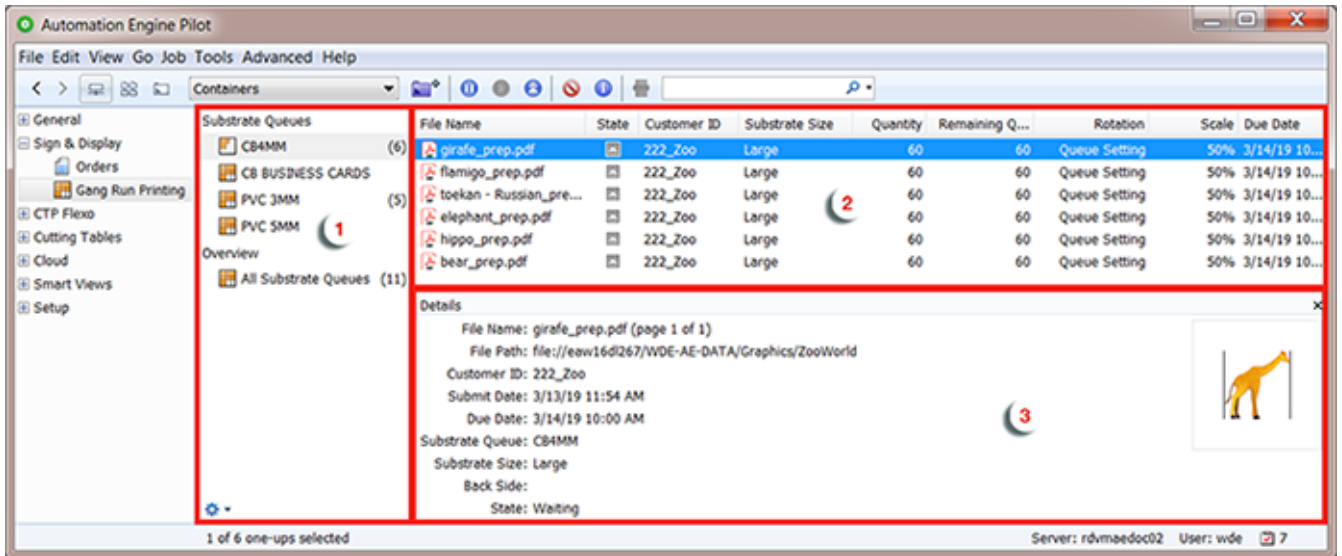

1. Substrate queues.

- Select CB to see which one-ups are in this queue at the moment.



**Note:** One-ups can be graphics but can also be CAD files.

- Or choose **All Substrate Queues** to see the contents of all of them. In the contents view ('2'), make sure you see the column **Substrate queue** so you can still see which queue these items are in. The column **Order ID** will show which ones belong to the same order. You could choose to sort by any of these columns.
  - Right-click **All Substrate Queues** to start creating queues. or click the settings-button at the bottom.
2. One-Ups submitted for nesting on the selected substrate queue. Once they have been nested (and are no longer needed for other layouts), the output workflow starts for the layout they belong to and then they disappear from this list.
3. Details of the selected one-up.

From this view, you can:

- [Create or change substrate queues](#) and their characteristics,
- have an overview of all one-ups [submitted](#) to each substrate queue, and their [state](#),
- [change the parameters they were submitted with](#) or even [move them to another queue](#).
- [control the printing flow](#) (for example you can put some graphics on hold, or force-print some of them).

### 14.6.1. Working with Substrate Queues

When [submitting graphics](#) (or CAD files) to be nested on a substrate, they become an entry in the corresponding [substrate queue](#).

**Substrate Queues** are shown in the **Gang Run Printing** view. A number indicates how many entries have been submitted to that queue. For example: Polystyrene **2**.

The "nesting server" then calculates the best possible nested layout(s) for these entries, based on:

- the quantity that was ordered,
- the sheet sizes and nesting settings that you defined for that substrate queue.

When a substrate queue is busy calculating layouts, its icon becomes animated .

You can also **pause** a substrate. This stops its automatic calculations. The icon changes to . Learn more [here](#).



**Important:** We strongly recommend that you define your substrate queues before submitting graphics to them.

If you submit graphics to a substrate queue that is not defined yet in the list of **Substrate Queues** (by entering an unknown substrate in the *Submit to Gang Run* task), then this substrate queue will be created automatically in the **Substrate Queues** list, but it will miss crucial parameters (such as sheet sizes and a link to an output workflow).

In such a case, the nesting server is not able to calculate layouts for it and a warning sign on the substrate icon  indicates that the substrate queue isn't properly configured. In this case, make sure to [add the missing parameters](#).

### Adding a Sheet Substrate Queue

1. Click the action button  at the bottom of the **Substrate Queues** list and select **New Substrate Queue...**

You can also

- go to **File > New Substrate Queue...** or press **Ctrl + N** on Windows / **Cmd + N** on Mac.
- right-click any other queue and choose **New Substrate Queue...**

2. In the **New Substrate Queue** dialog, select the icon for the type **'Sheet'** click **OK**.



**Attention:** In this page, we continue explaining how to set up a Sheet based substrate queue. Learn how to add a Roll based substrate queue in '[Adding a Roll Substrate Queue](#) on page 998'.

3. In the **New Substrate Queue** dialog, enter a **Name** for this substrate queue.



**Note:** Substrate queue names (and also names of their sizes, see below) are often used in names of output files. That is why it is advised to avoid too special characters in these names.

4. **Material:** When you are using a Kongsberg table to cut the print results, this field serves to communicate the exact name of the material to the cutting table. It is then already part of the job specification on iPC. Mind that only the formats i-script and JDF (Kongsberg) will contain this name of the material and so allow the cutting table to select the right material settings.

Click  to see a list with all materials that are currently configured on your Kongsberg tables (that you added as a *Device*). Select the one you want for this substrate queue and click **OK**.



**Note:** If you type in a name of a material that is not yet in that list, it will appear with that name in iPC. You can there choose to add it to the list in iPC.



When you leave this field blank, the name of the substrate queue will be used instead.



**Note:** This field has no use when you do not use a Kongsberg table.

5. Click **Add** to add a **Sheet Size** for this queue. Learn more in [Adding Sheet Sizes](#) on page 987.



**Attention:** You need to define at least one sheet size per substrate queue, otherwise graphics sent to this substrate queue will not be nested and printed.

6. Click **Nesting Settings...** to define how this queue will create a nested layout. Learn more in [nesting settings](#).
7. In **Output Workflow**, [select the output workflow](#) that will be launched on the nested layout(s).



**Attention:** You need to define an output workflow here, otherwise you won't get production files for the files you submitted to this substrate queue!



**Note:** An output workflow will be launched as soon as a nested layout is made that fits the queue's settings.

8. Click **OK** to save your substrate queue.



**Note:** It is possible to save your substrate queue without having defined all the necessary settings (for example if you haven't linked a workflow to your substrate), but you will get a warning message and the substrate queue icon  will show a warning sign.

If this is the case, you need to [edit your substrate queue](#) to define the missing settings. When you are done, you should see this default icon for a substrate queue: .

## Adding Sheet Sizes

For every sheet size you want to add:

1. Click **Add** (on Windows) or **+** (on Mac).
2. In the **Add Sheet Size** dialog, enter a **Name** for the sheet size.
3. In the **Size** parameters, enter the sheet's width and height.

The units used here are those you defined in the Pilot Preferences (in **Edit > Preferences > Units** on Windows or **Automation Engine > Preferences > Units** on Mac).

4. Enter the **Margins** to use.

The margins won't contain nested graphics, but can contain marks.

5. **Usage:** Select one of these extra selection criteria, next to size.

- **Preferred:**

- Will be used whenever possible.
- Typically for offcuts and scrap material that you want to be used first.
- Other use case: You have a roll-fed printer and 2 widths of paper rolls. When you have the wide roll mounted, you may set that one as your preferred one. This avoids having to switch these rolls too often. And when you mount the other roll, you then set that one as your preferred one.

- **Standard:**
  - Default value
  - Only when the graphics can not be positioned on 'preferred' sheets.
- **Exceptionally:**
  - Typically for expensive sheets. You want good control over when this special material is used.
  - Only used when there are graphics that don't fit on the other substrate sizes.



**Note:** One of the above will only be considered when the submit task had the **Substrate Size** on 'Any'.

6. If you want, you can keep track of the stock you have of that sheet size.

To do this, select **Keep track of stock** and enter the number of sheets you currently have **Available in Stock**. Every time the nesting server uses that sheet size for a nested layout, it will be subtracted from the available quantity.



**Attention:**

- When **Keep track of stock** is selected and the stock reaches 0, the nesting server no longer create layouts that need that sheet size.

This can cause graphics to be stuck in the substrate queue (when this was the only sheet size defined for that substrate queue, or when you chose to nest the graphics *on that sheet size specifically*).

When you again get sheets available in that size, you should re-edit the available quantity.

As introduced in [Keeping Track of your Stock](#) on page 983, the stock of sheet (or roll) sizes can also be controlled from an external system. Learn more in [Import Gang Run Substrate Sizes from XML](#) on page 1008.

- When **Keep track of stock** is not selected, no quantity is shown. The nesting server then also does not check this and will so always be willing to create a layout using this size.

7. Click **OK**.

The resulting list of sizes also show a column **Available in Stock**. When **Keep track of stock** was not selected for a size, no number will be shown.

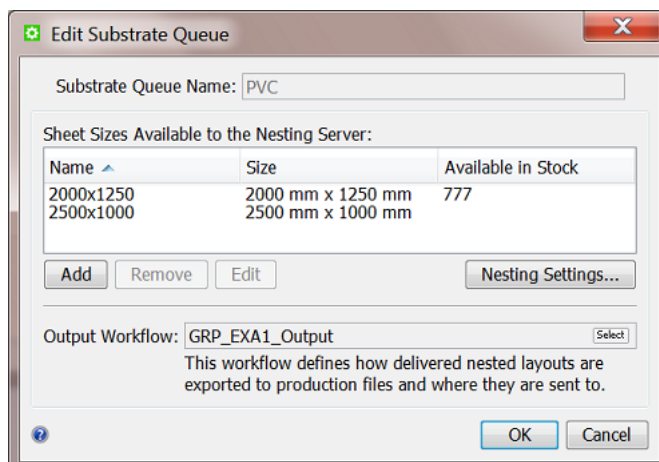

## Defining Nesting Settings for Sheets

### Minimum Fill Tab

- Enter a **Minimum Fill** if you only want to output the sheet when it's filled to a certain level. By default, the minimum fill is set to 75%.



**Attention:** Do not put 100% here as only the graphics inside the cut path count as fill. The margins, gutters etc. all count as waste.



**Note:** When nesting is based on an irregular shape, be aware that a minimum fill may need to be set quite low. Here is an example of a layout that looks rather full but still only has a fill rate of 38%:

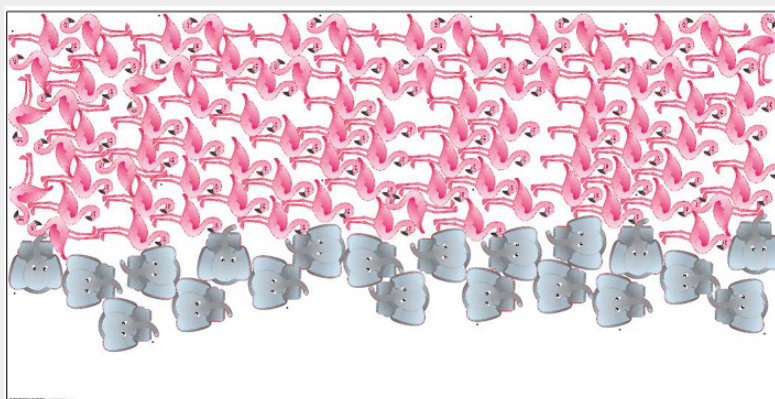

**Note:** Some users still prefer to put this % to a very high level because they deliberately want to avoid any nesting happening automatically. They prefer to use the tools in the ['Show Layouts' view](#) to have full manual control over their creation.

- **Overrule Minimum Fill:** Set the hours and minutes before the due date at which you no longer want to wait for the minimum fill, because the job-order becomes too urgent.

**Layout Tab**

- Select the **Nesting Type** to use for the layout:
  - **Minimal Waste** tries to reduce the waste in material to a minimum.
  - **Minimum Layouts** aims to generate as few layouts as possible, potentially at the cost of having some more waste.



**Tip:** Having fewer layouts can reduce setup time, making this option interesting for offset printing.

- **Guillotine Cut** generates layouts that can be cut on a guillotine cutting table (which can only cut in straight edge-to-edge movements).

This usually reduces the number of cuts per layout but may increase the number of layouts and the waste.

In the example below, the layout on the left can not be cut on a guillotine table. The one on the right can, but includes one graphics or copy less:

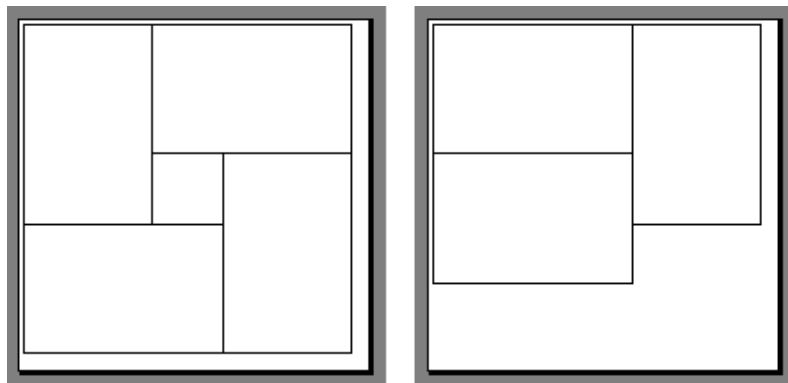

- Select the **Search Method** to use for calculating the layout.
 

Depending on if you are running a test or processing graphics for production, you can set the layout search from **Very Fast** to **Slow (Very Accurate)** (the faster the search, the less accurate the result can be).
- **Graphics Order:** (disabled when choosing **Minimal Layouts**). Once the calculation for the chosen nesting type is done, the system needs to decide in which order the one-ups will be placed.
  - **Any:** The order of the one-up on the layout(s) is based on its size, taking the largest one first.
  - **By Submit Date:** This will nest the graphics in the order in which they are were submitted to the substrate queue.

The position where the graphic is placed is decided by the nesting software. This means that the graphic will likely to be placed near the previously placed graphic (although there is no 100% guarantee). In case of guillotine nesting, which has a more strict notion of rows and columns, selecting this option will be more clearly reflected in the output rows and columns.



**Note:** When graphics have different sizes, it can happen that no space is found for some graphic but that the next graphic can be placed. For example: A sequence of A, B, C, D, E, F comes in, producing a layout with A, B, D and a layout with C, E, F.



**Note:** Before v18.1, this choice was called 'Respect the graphics order'.

- All other methods: **By Order ID, By Customer ID, By Custom Field 'x'**: The order of placing is, as mentioned above, based on the size, but you can here select a method that the system will use to group all graphics that have the same value for that selected method.



**Note:** Custom fields that are used as a grouping key are not available here (grouping keys are used to sort graphics over different sheets).



**Attention:** When, for example, you choose 'By Order ID', but these ID's are (almost) all different, then the system cannot really make any groups... The groups will then be groups of '1'. And then it will fall back on deciding the sequence by size (the default). Note that it will *not* check the order ID *values* to decide the sequence, it only uses the value to try to make these groups!

- Depending on the **Nesting Type** you selected, you can set extra options:

Table:

When you selected...	...you can set:
<b>Minimal Waste</b> or <b>Minimum Layouts</b>	<ul style="list-style-type: none"> <li>• the <b>Fill Starting Point on Sheet</b> (where the first graphic will be placed): at the <b>Top Left, Top Right, Bottom Left</b> or <b>Bottom Right</b>,</li> <li>• the <b>Primary Fill Direction</b> (in which direction the sheet will be filled): <b>Horizontal</b> or <b>Vertical</b>.</li> </ul>
<b>Guillotine Cut</b>	the direction of the <b>First Cut: Horizontal, Vertical</b> or <b>Don't care</b> .

- A **Gutter** is the distance between the cut-paths of 2 stations. If it is zero, then these stations have a common cut-line.
- If the graphics in your files have a bleed outside the cut path, you can clip it away by entering the bleed distance in **Bleed Clipping Mask**.



**Note:** An example: When there is a gutter of 10 mm, then both stations better not have more than 5 mm bleed. To avoid that their bleeds overlap, set a mask to clip the bleed to 5 mm or less.

- **Maximum Overrun:** When choosing the **Nesting Type 'Minimum Layouts'** or **'Guillotine Cut'**, you can choose to allow the nesting server to print a few extra copies of some of the graphics, so that you have more printed sheets with the same layout.

Allowing some overrun increases the chance of getting the least amount of layouts. This reduces the amount of plates needed for offset printing, so reducing the amount of needed press setups.

- If you want to do this, set a **Maximum Overrun**. For example set a **Maximum Overrun** of 10.0% if you don't mind printing up to 10% more of some of the graphics to have less layouts.
- If you only want to print the exact ordered quantity of each graphic, and don't mind the number of layouts, keep the Maximum Overrun at 0.0%.

- **An example:**

You need to print 100 "BLUE" graphics and 10 "RED" graphics, on a sheet size that can fit 10 graphics.

- If you don't allow overrun, you will have 2 layouts:
  - A layout with 9 "BLUE" and 1 "RED" graphics, to be printed 10 times (giving 90 "BLUE" and 10 "RED" graphics).

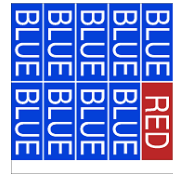

- A layout with 10 "BLUE" graphics, to be printed 1 time (for the remaining "BLUE" graphics).

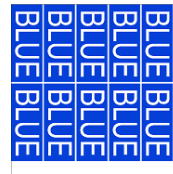

- If you allow a **Maximum Overrun** of 20.0%, you will have only 1 layout, with 9 "BLUE" and 1 "RED" graphics, to be printed 12 times.

This gives 108 "BLUE" graphics (8% more than ordered) and 12 "RED" graphics (20% more than ordered).

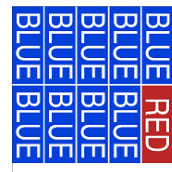

- In **Rotation**, specify if the nesting server is allowed to rotate the graphics in the layout to get a better fit. You can choose:
  - **Allow Any Angle**,
  - **Allow 180 degrees** (clockwise),
  - **Allow 90, 180 or 270 degrees** (clockwise),

- **Not Allowed.**

**Offcuts Tab**

**Concept**

- Offcuts are unused rectangular parts of a sheet that were cut off but that you still want use. Selecting '**Save offcuts**' in this tab outputs offcut areas as XML files. This can be **one XML file per layout PDFPLA file** that this task creates. The XML file describes one or multiple offcut areas. An example: The XML from this PDFPLA layout would describe 2 offcuts areas:

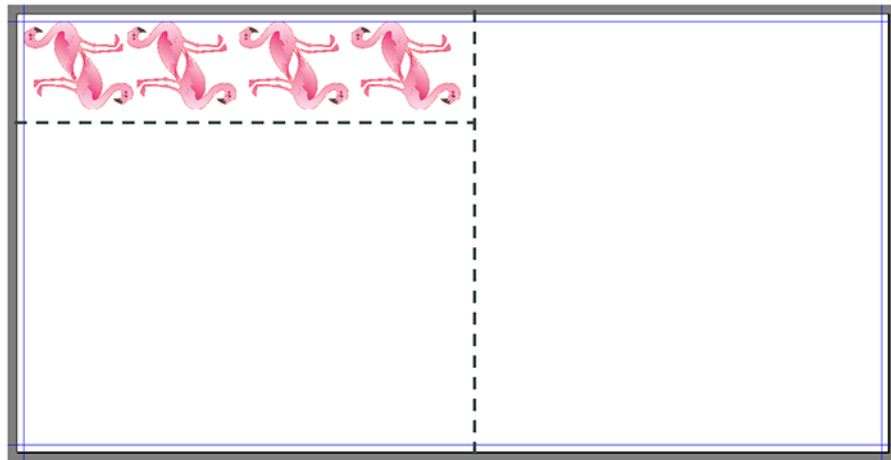

- When you use the task '[Import Substrate Sizes from XML](#)' on such an XML file, that offcut sheet size will appear in the list of **Sheet sizes** of that **Substrate Queue**. They so become available for the nesting server. An example: See how next to the manually defined sizes 'Large' and 'Small', there are also various sizes named after their custom size:

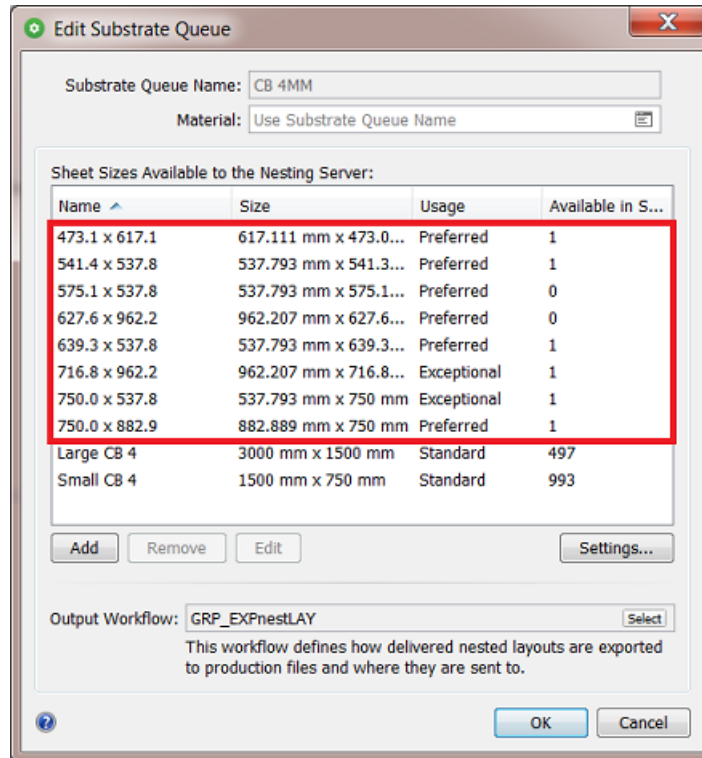

- We can distinguish different workflows in using offcuts:
  - **Automatic:** The system decides to use the offcut sheets as soon as they become available as a sheet size.
  - **Manual:** You decide when it's time to start using (specific) offcuts.

Learn more below about these workflows.

- You can also work with offcuts that you already made in I-Cut Layout. Learn more below.

### Settings

- **Save offcuts.** Select this to have the system save offcut areas as an XML file. Mind that one XML file can describe multiple offcut areas.  
See below description on what to do with these XML files (importing them automatically or manually).
  - **Minimum Width and Height.** Enter a value to limit offcuts to those that minimally have this size (in both directions). For example: '500 mm'
  - **Restrict amount of offcut sizes.** Select this to restrict how many different sizes of offcuts you want.
  - **Extend Minimum Size with Steps:** An example: Enter '100 mm' to only save offcuts that are any step of 100 mm larger than the here above specified minimum size. This will then only create offcuts with size 500, 600, 700... etc.. This fixed set of possible sizes reduces the amount of offcut sheet sizes.



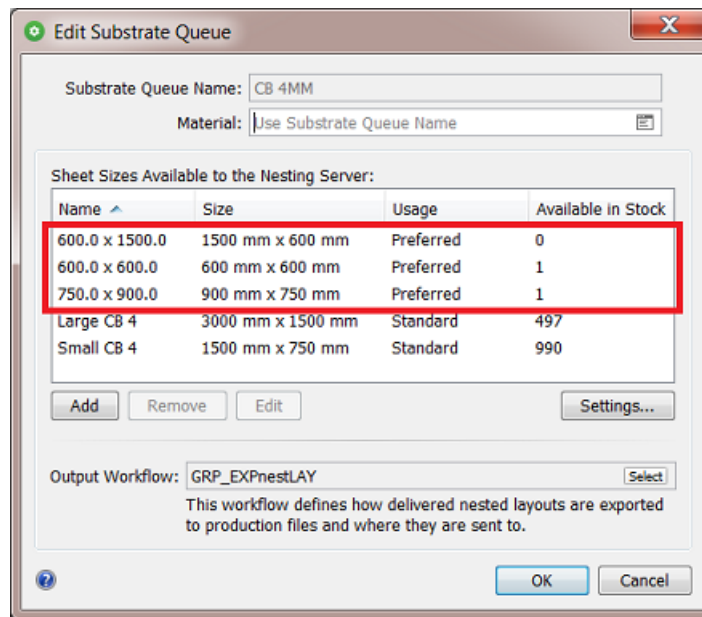

When this setting is not selected, the system will save any size of offcut sheet.

- **Safety Margin:** You can add an extra margin around the (bounding box of the) printed area. This will make the offcut smaller.



**Note:** The offcut size can also be reduced by any i-Cut marks that also take up some space on the sheet.

### Automatic or Manual workflow

The difference between the two is how and when you import those XML files into Automation Engine's database of sheet sizes:

- **Automatic workflow**

To see the offcut sheet sizes automatically appear in your list of sheet sizes, add the task [Import Substrate Sizes from XML](#) to the output workflow of that substrate queue and make sure it imports the offcut XML files.

An example:

- In this output workflow, see how the task [Export Gang Run Layouts](#) also has a dedicated output pin for the XML files that describe offcuts:





**Attention:** The output pin 'Offcuts' requires an 'Export Gang Run Layouts' ticket from AE v18.1.1 or later. To see the 'offcuts' pin on workflow tickets that you made sooner, just open and close that ticket to make this pin appear.

- When this workflow sends those XML files to the *Import Substrate Sizes from XML* task, they will automatically appear in the list of sheet sizes of that queue. See an example above in the first picture that shows the 8 offcuts that were imported. Their parameters are defined in the ticket of the *Import Substrate Sizes from XML* task.



**Note:** Offcut (or other) sheet sizes that have 0 in stock are not removed automatically.

These offcuts can be used by the system from the moment they appear. When you do not want that to happen, you could for example add a 'Wait' step before importing, or make a dedicated Substrate Queue for offcuts, or pause a queue and first check its contents etc. Or you can have full manual control, as we describe next.

• **Manual workflow**

When you want full control over when and how the offcuts are used, then just manually use the *Import task* when you want, and on the XML files you want.

For example: Each Friday afternoon, you want to produce using the offcuts of that week.

An example:

- This time, the output workflow does *not* include the task *Import Gang Run Substrate Sizes from XML*. We'll only import them Friday noon.



See how this example moves the offcut files to a separate folder: You could do this for example to make it easier to access or select them, or to avoid that they get imported somehow...

- At the time you want to use the offcuts, go to their folder in the Files view in the Pilot.

When you didn't specify an output folder, these XML files are by default written in `\ExampleJobContainer\SnDTemp`.

Select the ones you want to import and launch this type of workflow that also moves or deletes the imported ones, this to avoid that you import them again.



**Note:** Notice that you need to use the 'Mark File' tools because this Import task does not report any output files.

### About the Name of an Offcut XML file

Their name is decided by the field '**Output Name**' in the '[Export Gang Run Layouts](#)' task. Learn more [here](#).

The below table shows an example when using the [default set of SmartNames](#) in this field:

**Table: Default (SmartName based) name of an Offcut XML file**

Part type	Part	Meaning	Example
SmartName	wfp.substrate	Name of the substrate queue	CBstndrd 4mm
SmartName	wfp.substrate.size	Name of the sheet size that was selected to produce	Large 3000x1500
SmartName	wfp.substrate.size.quantity	Amount of offcut sheets of this size output by this workflow task	1
SmartName	shortid	Short ID nr of the task that produced this offcut	2712
Fixed	OFFCUT_	Automatically added to help identify the XML file	OFFCUT

Resulting name: CBstndrd 4mm\_Large 3000x1500\_1\_2712\_OFFCUT.xml



**Note:** One XML file can have the description of multiple offcut sheet sizes. This is why we can not add the size to name.

### Offcuts already made in i-cut Layout

When you already made one or more offcuts in the editor **i-cut Layout**, they will be saved in the resulting PDFPLA.

When, in Automation Engine, you launch the task Export Gang Run Layouts on that PDFPLA file, those offcuts will also be exported as an XML file.

### Linking a Workflow to Your Substrate Queue

Select the output **Workflow** to launch on the layouts that the nesting server created. This workflow minimally needs the [Export Gang Run Layouts](#) task.

This [output workflow](#) will be launched either:

- when the [minimum fill percentage](#) for that substrate queue is reached,
- in time for the submitted graphics's [due date](#) (if they have one),
- when you [force print](#) one or more graphics from the substrate queue.



**Attention:** You must link an output workflow to your substrate queue, otherwise you won't get production files for the graphics you submitted to that substrate queue!

## Adding a Roll Substrate Queue

Adding a substrate queue for a roll is very similar to adding one for a sheet, as explained in [Adding a Sheet Substrate Queue](#) on page 986.

When you add a **New Substrate Queue**, you there select the icon for the type **Roll**.

We here list the other differences:

### Adding Roll Sizes

**Adding a Roll Size** is identical to [Adding Sheet Sizes](#) on page 987, with these differences:

1. The **Size** is the width of the web (across the roll).
2. You can define a **Min** and **Max** length (along the roll):



**Attention:** Nesting on roll will:

- generate a layout in case the layout exceeds the minimum length and reaches the minimum fill percentage. In case the due date has expired, a layout will be generated even if the minimum length is not reached.
- reject graphics that exceed the maximum length (these graphics can't fit on the substrate).
- always set the **Primary Fill Direction** or **First Cut** to the direction across the roll.



**Note:** In case the PDF file for printing needs a different orientation, use the rotation option in the **Export Gang Run Layouts** task.

3. **Usage:** A use case to have a type of roll as '**Preferred**' roll size, is that you prefer continue using this roll that was mounted already than going through a roll-change. So temporarily it is your preferred substrate.
4. **Stock:** With roll sizes, the stock is the amount of meters left on all your rolls of the same type of substrate. It is a 'global' stock for that roll. It is not the amount of rolls or the amount per roll.

### Defining Nesting Settings for Rolls

Roll **Nesting Settings** are identical to [Sheet nesting settings](#), with these differences:

- The **Primary Fill Direction** is always vertical, across the roll.
- **Fill Starting Point on Roll:** choose the icon for **Top Right** or **Top Left**. The filling will always be across the roll.
- When the nesting type is **Guillotine cut**, there is no **First Cut** setting. It will then always be across the roll.

### Linking a Workflow to Your Substrate Queue

This is identical [as we explained for sheet type substrates queues](#).

### Editing a Substrate Queue

1. Double click the substrate queue that you want to edit.



**Tip:** You can also go to **File > Open** or press **Ctrl + O** on Windows / **Cmd + O** on Mac, or click the action button  and select **Open**.

- In the **Edit Substrate Queue** dialog, you cannot change the substrate queue **Name**, but you can edit all the other settings.



**Note:** If you want to change the substrate queue name, we recommend you [duplicate the substrate](#) under your chosen name and then delete the original substrate queue.

- You can add, modify or delete sheet or roll **Sizes**.
  - To add a sheet size, click **Add** (on Windows) or **+** (on Mac) and define the sheet or roll size settings (for [sheets](#) or for [rolls](#)).
  - To modify a size, select it, click **Edit** (on Windows) or  (on Mac), and change the settings.
  - To delete a size, select it and click **Remove** (on Windows) or **-** (on Mac).
- Click on **Nesting Settings...** to check or change [nesting settings](#) for this substrate queue.
- Check or change the **Output Workflow** that this queue will launch on the nested layouts.
- Click **OK** to save your changes or **Cancel** to revert.



**Note:** After changing the settings, the nesting server will automatically re-calculate nesting layouts for the graphics in that substrate queue, even if no new graphic was submitted.

## Duplicating a Substrate Queue

- Select the substrate queue that you want to duplicate, click the action button  and select **Duplicate....**

You can also

- go to **File > Duplicate...** or press **Ctrl + D** on Windows / **Cmd + D** on Mac.
  - right-click any other queue and choose **Duplicate....**
- In the **Duplicate Substrate Queue** dialog, enter a **Name** for the new substrate queue.
  - The queue settings are the same as the old substrate queue's, but you can modify them if necessary.
 

See:

    - [Adding Sheet Sizes](#) on page 987 or [Adding Roll Sizes](#) on page 998.
    - [Defining Nesting Settings for Sheets](#) on page 989 or [Defining Nesting Settings for Rolls](#) on page 998.
    - [Linking a Workflow to Your Substrate Queue](#) on page 997.
  - Click **OK** to save your new substrate queue.

## Deleting a Substrate Queue

- Select the substrate queue that you want to delete and press the **delete** key.



**Tip:** You can also go to **File > Delete** or click the action button  and select **Delete**.

2. In the dialog that pops up, click **Delete** to confirm that you want to delete that substrate queue.



**Note:** When you confirm to delete, also a queue that still has graphic entries will be deleted.

### Pausing and Resuming a Substrate Queue

- Right click the name of a substrate queue and choose **Pause Substrate Queue** to stop the queue from calculating layouts. Any already running calculations will still continue until finished.

The icon will change to .

- Right click the name of a paused substrate queue and choose **Resume Substrate Queue** to reactivate the automatic calculations. This action itself is also a trigger to recalculate.

The icon will change back to .

## 14.6.2. Working with Substrate Queue Entries

### Overview of Substrate Queue Entries

#### List of Entries per Substrate Queue

The name of each **substrate queue** is followed by a number that indicates how many entries it has (graphics or CAD). For example:  Polystyrene **2**.

Select the substrate queue to see a list of its entries on the right, including some printing information. Select an entry to see a bottom pane showing some **Details**.



**Tip:** When this list is long, use the filter in the menu bar to easily find back entries. You can filter on **File Name**, **File Path**, **Customer ID** and **Substrate Size**.

#### Printing Information

For each entry, you will see this information, defined by the settings that were chosen when *submitting* the entry to that queue:

- the **File Name** of the entry and the page to be printed,
- the **File Path**,
- the **Customer ID**,
- the **Submit Date**,
- the **Due Date**,
- the **Substrate Queue**. This can be important when viewing **All Substrate Queues**.
- the **Substrate Size** it should be printed on (if this was defined when submitting the entry),

- the **Quantity** ordered,
- the **Remaining Quantity** to be printed (if some copies of the entry have already been included in a nested layout, this is what remains in the queue). When this number drops to '0', this entry is removed from this queue.
- the **State** of the entry in this substrate queue (learn more on states of entries below),
- the date it was submitted (**Submit Date**),
- the **Rotation**,
- (if used) **Custom labels**. These may have been used as grouping key or just serve a labels (here and in the report PDF). Learn more about their use in [the page about the 'extra' tab of the 'Submit' task](#).

If you want to find a specific entry in this overview, you can filter the list using the search field

, or sort the entries by clicking the column header. The sorting order has no influence on the output.



**Tip:** You can also show / hide or reorganise columns by going to **View > Select columns in 'Gang Run Printing'...**

For example, you can also show columns with your [labels and grouping keys](#) and use that to sort entries.

### States of Queue Entries

⏸	<p>The entry is <b>waiting</b> to be placed on a layout.</p> <p>When the nesting server calculates possible layouts, it will try to include all of the entries in this state in the most efficient layout(s) possible.</p> <p>A typical reason when an entry has this state for a long time is that the minimum fill percentage is not reached.</p>
⏹	<p>The entry is <b>on hold</b>.</p> <p>Entries in this state will not be included in the layout calculations.</p>
⏏	<p>Someone requested this entry to be <b>forced out</b>. This forces it to output regardless of the fill percentage of the layout(s) that it is placed on.</p> <p>It is still in this queue because not all related layouts were exported yet.</p>
❌	<p>The entry checked and <b>rejected</b> by the nesting server. It can not placed on a layout. The <b>Details</b> pane below explains why:</p> <ul style="list-style-type: none"> <li>• Because it is <b>too big</b>. It could be that: <ul style="list-style-type: none"> <li>• The entry is too big for any available size of that substrate. In this case, consider either <a href="#">defining a bigger sheet size</a> (if you have some available), or choosing a different substrate in <b>Edit</b> mode or when <a href="#">re-submitting</a> this entry to the queue.</li> <li>• The entry is too big for the substrate size that you chose when submitting it to the queue. In this case, choose a bigger size, or set the entry to be nested on <b>Any</b> size of your substrate. Do this in <b>Edit</b> mode or when submitting it to the queue.</li> <li>• The entry is too big to fit within the rotation possibilities of this substrate queue. In this case, change the <a href="#">rotation parameter</a> to <b>Allow any angle</b> (when in <b>Edit</b> mode) or change it in the <a href="#">Submit to Gang Run task</a> (which can overrule the setting of the substrate queue).</li> </ul> </li> </ul>

If none of these solutions help, you need to **tile** your entry before submitting it to the substrate queue.



- Because the file (or its backside) **can not be found**.
- Because the **cut path is not closed**. The system fails to create a closed outline based on the selected cut path.
- Because the system **failed to set cut path** using the selected ink name.
- Because the number in stock of the requested substrate size is insufficient.

## Managing Substrate Queue Entries

By default, entries in a substrate queue will **automatically** be sent to the output workflow

- either when they were placed on a layout with the *desired minimum fill*
- or when their due date has come (or the *time that was set before their date*).

You can however also manage these entries **manually**. Right-click them or use the menu bar to chose a function:



- Select one or more and click the **Hold** button . An entry that is on hold will not be considered in the calculation of layouts, even when its due date has passed. In the column **'State'**, the icon changes to: .



**Note:** Alternatively, you can choose to put the whole queue on hold. This will stop the queue from calculating new layouts, even when new entries come in.



**Note:** You will notice that if you delete or put a queue entry on hold that was already placed on a layout, that this triggers a re-calculation of the layouts (unless the queue was put on hold). You can see this more visual when you work with *the Layouts Gallery*.

- To release entries that are on hold, select them and click the **Release** button . In the column 'State', their icon changes back to the (default) icon  ('waiting').
- **Force out:** This forces the creation of one or multiple layouts containing that entry regardless of the fill percentage of the layout(s). Select one or multiple entries and click the **Force out** button .



**Attention:** To get a better substrate usage, some other entries that you didn't select may be printed along with the entries you forced out. In this case, you will see that either these entries (also) disappear from the list, or that their **Remaining Quantity** is reduced.

Entries that are on hold will not be included. If you want to force out an entry that is on hold, you need to release it first.



**Tip:** When, even after a while, still nothing happens with the entries that you forced out, check if the substrate size that was requested for those entries:

- (still) exists
- still has stock left (learn more in *Keeping Track of your Stock* on page 983).



- **Show Layouts:** This opens the layouts gallery and shows the layouts that this entry was placed on. Learn more in [Viewing and Choosing Nested Layouts](#) on page 1004.
- To remove entries from the queue, select them and click the **Delete** button . You will be asked to confirm.



**Note:** This will not delete the file of that entry. It only removes it from that substrate queue.



**Note:** You will notice that if you delete or put a queue entry on hold that was already placed on a layout, that this triggers a re-calculation of the layouts (unless the queue was put on hold). You can see this more visual when you work with [the Layouts Gallery](#).

- **Edit:** This allows to make changes to how this entry was submitted. Alternatively you could remove the entry and use the tasks to re-submit it with the different settings.

Select one or multiple entries and choose **Edit**.



**Important:** Currently, you can only edit multiple entries when they are in a same substrate queue.

You can adapt these settings:

- **Quantity:** Type in the new (absolute) value.



**Attention:** The entry will immediately disappear from the queue when the new quantity is

- less than the remaining quantity
- 0
- a negative number rounded off to '0' .

- **Substrate Size**
- **Scale**
- **Rotation**
- **Due Date**
- **Custom fields**



**Note:** When you selected multiple entries before clicking 'Edit', some of their settings may have different values. When that is the case, the value field will be greyed out and mention **'Mixed'**. You can overrule this by simply typing in or selecting a new value which will then be used for all entries in your selection.



**Note:** When a user clicked **Edit**, the queue is automatically locked: 

When you click **OK** to confirm the changes, the queue becomes active again and:

- All layout proposals that contain the selected one-up(s) are removed from the list of layout proposals.

- A new nesting calculation is triggered on the substrate queues to which the affected one-ups belonged.



**Note:** The substrate queue will be locked while one of its entries is in this 'Edit' mode.



**Note:** The changes that you here make to the quantity will also be updated in the **Orders** view.



**Note:** You can't edit an entry when another user is already 'editing' it. A message will appear. It will also mention the name of the user that is blocking the access.

- **Move to:** This allows to move one or multiple entries to another substrate queue.

Right-click the entries (of a same substrate queue), select '**Move to...**' and choose the new **Substrate Queue** and **Size**.



**Note:** The substrate queue will be locked while one of its entries is in this 'Move To' mode.



**Note:** You can't move an entry when another user has already opened that dialog. A message will appear. It will also mention the name of the user that is blocking the access.

- **Go to File:** This opens the **Files** view and selects the file for that queue entry. This can be useful to launch some task on it or to check related files.
- **Info** (or click 

### 14.6.3. Viewing and Choosing Nested Layouts

#### Concept

##### Concept

Nested layouts that do not have the required minimum fill will not be output automatically. Still, you can open a gallery view to see these **layouts that are considered to be not good enough** yet. And you can even select them to print anyway.

There are 2 main use cases:

- When you want to check the nesting process of a specific substrate queue in detail, you want to see the gallery of all layouts that that queue calculated for all its entries.
- When you wonder why a specific entry is still waiting in a substrate queue, you want to see the gallery of only the layouts that this queue entry is part of.

##### Manual Control over Layouts

Some customers prefer to always check the layouts visually and then manually decide when which ones are good enough to print. To avoid that any automatic nesting takes place, they typically put the minimum required fill percentage very high (for example 95%).

## Working with the Layouts Gallery

### Opening the Layouts Gallery

- Right-click a substrate **queue** and choose "**Show Layouts**" (or use Alt+Cmd+Down) to see the layouts that were calculated of all entries in that queue (that have the status 'waiting').
- Right-click an **entry** in a substrate queue and choose "**Show Layouts**" (or use Alt+Cmd+Down) to see only the layouts that contain that entry.

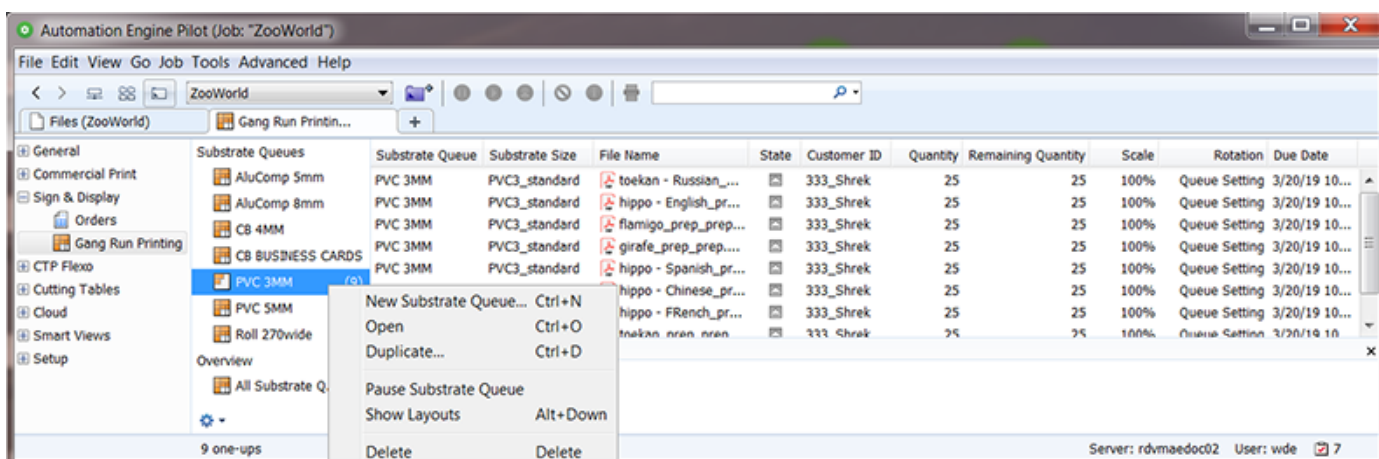

### The Layouts Gallery

This gallery automatically refreshes when any changes occur. These changes can be caused by:

- one or more new entries in a queue
- one or more queue entries were put on 'hold'
- one or more queue entries were deleted
- the queue was resumed after being paused
- the settings of the queue were changed.

See this example, the numbers are explained below:

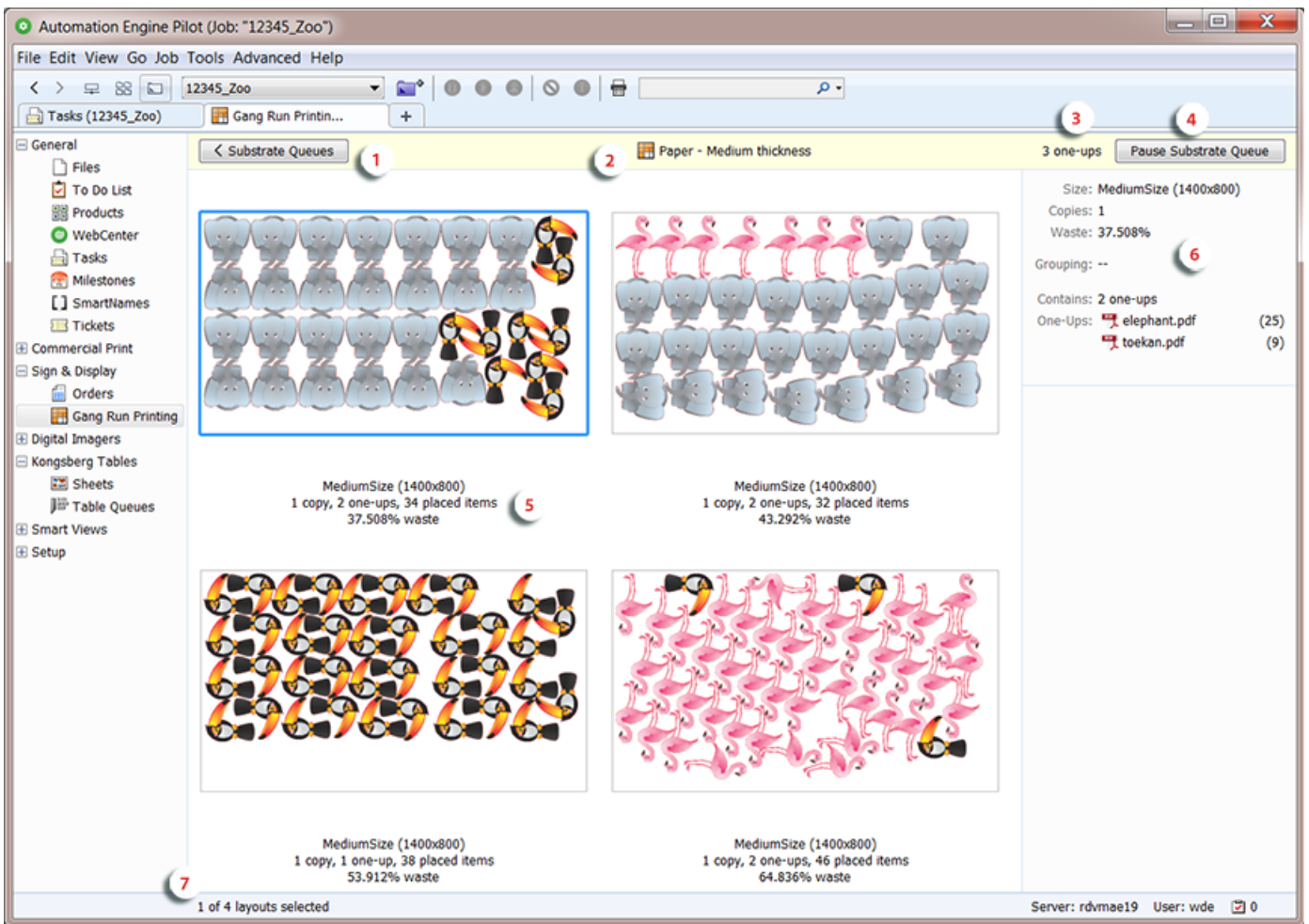

**Important:** You can choose how the layouts are sorted in this gallery. Right-click one of them and choose to **Sort by**:

- **Waste**
- **Due Date**

1. Click '< **Substrate Queues**' (or use ALT/Cmd-Up) to return the list of queues and their entries.
2. Name of the substrate queue.



**Tip:** Just like in the list of substrate queues, the icon adapts to the queue's state (active / paused / animated when calculating).

Double click the queue name to open the dialog with the queue's settings.



**Attention:** When you make any changes to a queue's settings, a layout calculation will be done right after you close this dialog.

3. The amount of **one-ups** of which the layouts are currently shown.
4. Click '**Pause Substrate Queue**' to prevent it from calculating (new or different) layouts. When paused, click '**Resume**' to resume the calculations (one will be done instantly).
5. Below each preview, three lines describe the layout:

- Top line: The name of the **Sheet** or **Roll Size** used for this layout (the *name as defined in the substrate queue*).
- Middle line:
  - **copies**: How many times this layout needs to be printed to produce the required quantities.
  - **one-ups**: How many different files (graphics or CAD) are present on this layout.



**Note:** CAD files (ARD) are visualized with a random selected color.

- **placed items**: The total amount of placed items on this layout.
- Bottom line: The percentage of **waste** on this layout.



**Note:** Any possible *offcuts* are visualised in the display by a thin light red line.

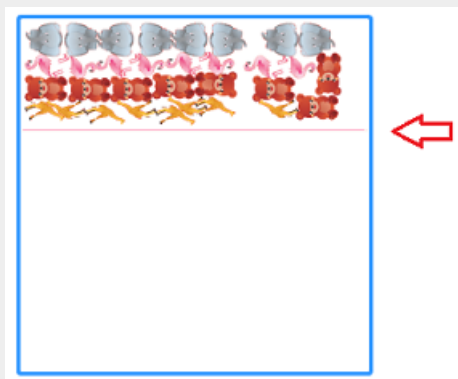

Offcuts are also visualised in this way when opening the PDFPLA file in the Viewer or I-cut Layout.

- The right pane shows details of the selected layout.
  - **Substrate Queue, Substrate Size, Copies, Waste**: See above.
  - **Due Date**
  - **Grouping**: These are the values of the parameters that were involved in grouping these one-ups onto a same layout. For example the grouping keys used in the *Submit to Gang Run* task.
  - **Contains**: How many different one-ups are present on this layout.
  - **One-Ups**: The file name and the amount of times it is placed on the selected layout.



**Attention:** When you asked to see the layouts of only a selection of items in the substrate queue, the names of these files will here be highlighted. For example:

One-Ups:	elephant.pdf	(25)
	flamigo.pdf	(7)

When you select a name of a one-up, the bottom pane shows more details. For example:

- **Quantity:** Total amount of copies of this one-up that was ordered to be printed (output).
- **Remaining Quantity:** Amount of copies of this one-up still to be printed.
- **Placed Quantity:** Amount of copies of this one-up placed on this layout.
- **Resulting Quantity:** Amount of copies of this one-up still to be printed once this layout is printed (how many then still need to be produced).

7. How many layouts are shown (and how many are currently selected).

### Printing a Layout from the Gallery

Although the layouts in this gallery do not meet the required fill percentage, you can still choose to print them.

To do this, select one or multiple layouts and click  in the menu bar. Alternatively, right-click them and choose **Print**.

This will remove those layouts from the gallery and start [the output workflow](#) assigned to this substrate queue.



**Attention:** The layouts that were not selected will not be printed, even when they contain the same one-ups.



**Note:** Requesting to **Print** a layout will fail when this queue is calculating at that moment.

Choosing to print one or more layouts changes the content of the layouts gallery. This is why the substrate queue then also automatically recalculates a new set of layouts.

## 14.7. The Gang Run Printing Tasks



**Note:** In a standalone setup of **Device Manager**, several of these tasks are not available.

### 14.7.1. Import Gang Run Substrate Sizes from XML

#### Concept

This task allows to use an XML file to

- import (and create) substrate sizes into the Gang Run Printing database
- update substrate size information (for example the available quantity).

This XML file typically comes from a business system: the MIS or ERP that also manages the stock of printing material. Such an XML file is very useful for example to regularly import a list of left-over stock entries (a.k.a. "offcuts").

### Usage

The task panel serves to map the language in the XML to the required terms in Automation Engine for these substrate parameters. The result will be visible in the list of substrate queues or in the details of their substrate sizes.



**XML Element Name:** You first need to specify the name of the XML element that contains the substrate size information.

Then, for each **Size Parameter**, select and click **Edit** to specify the corresponding **XML Element or Attribute** that is used in the XML file.

The **Size Parameter** 'Name' is the name of the substrate size and the **Size Parameter** 'Substrate' is the name of the substrate queue that that size will be added to (or be updated when already there).



**Important:** Substrate queues mentioned in the XML file that do not exist yet in Automation Engine are automatically created using the default nesting settings. Note that you will still need to complete their settings by adding an output workflow.



**Important:** All sizes are assuming the units as defined in the Pilot's [Preferences](#).

These examples illustrate the XML specifications:

### Example XML to Import Sheet Substrate Sizes

In this example, as shown in above screen shot, the **XML Element Name** is 'Size' and there are 2 such elements. Their XML attributes are also those that the default task ticket proposes. The 2 substrates described in this XML file are sheets. That is defined by their attribute **Type** 'P' (for 'Plano').

```

<?xml version="1.0"?>
- <ForEsko>
  - <Size>
    <Substrate>AluComp 5mm</Substrate>
    <Name>Medium</Name>
    <Type>P</Type>
    <Height>1000</Height>
    <Width>1500</Width>
    <TopMargin>5</TopMargin>
    <BottomMargin>5</BottomMargin>
    <LeftMargin>5</LeftMargin>
    <RightMargin>5</RightMargin>
    <Ranking>5</Ranking>
  </Size>
  - <Size>
    <Substrate>AluComp 8mm</Substrate>
    <Name>Large</Name>
    <Type>P</Type>
    <Height>1250</Height>
    <Width>2000</Width>
    <TopMargin>5</TopMargin>
    <BottomMargin>5</BottomMargin>
    <LeftMargin>5</LeftMargin>
    <RightMargin>5</RightMargin>
    <Ranking>9</Ranking>
  </Size>
</ForEsko>

```



**Note:** The parameters for margins are not mandatory. When they are not present the substrate size will fall back on the default settings (0).



**Note:** The element 'Ranking' defines the sheet size **'Usage'**: possible values are '1' for 'Preferred', '5' for 'Standard' (=default), '9' for Exceptional.

### Example XML to Import Roll Substrate Sizes

To *define a roll size*, the XML file needs XML attributes that the ticket then maps to

- **Type**, which for a roll is 'R'
- **Width**
- **Roll Minimum Length** and **Roll Maximum Length**.

An example (the default ticket will map these to the right **Size Parameters**):



```
<?xml version="1.0"?>
- <ForEsko>
  - <Size>
    <Substrate>MyStandardRoll</Substrate>
    <Name>RollNarrow</Name>
    <Type>R</Type>
    <Width>390</Width>
    <RollLengthMin>720</RollLengthMin>
    <RollLengthMax>900</RollLengthMax>
    <TopMargin>5</TopMargin>
    <BottomMargin>5</BottomMargin>
    <LeftMargin>5</LeftMargin>
    <RightMargin>5</RightMargin>
    <Ranking>5</Ranking>
  </Size>
</ForEsko>
```

### Method and Example XML to Update the Available Quantities of Substrate Sizes



**Note:** For sheets, the quantity is the number of sheets. For rolls the quantity is the amount of units (as defined in [Preferences](#)).

In the task ticket,

- the **Size Parameter "Available quantity"** allows to define a stock quantity of a substrate size.
- the **Size Parameter "Use available quantity"** allows to define whether the quantity of that size should be tracked (counted) when nesting layouts use that substrate size.

See an example (same syntax for sheet or roll):

```
<?xml version="1.0"?>
- <ForEsko>
  - <Size>
    <Substrate>MyStandardRoll</Substrate>
    <Name>RollNarrow</Name>
    <Type>R</Type>
    <Width>390</Width>
    <RollLengthMin>720</RollLengthMin>
    <RollLengthMax>900</RollLengthMax>
    <AvailableQuantity>5550</AvailableQuantity>
    <UseAvailableQuantity>1</UseAvailableQuantity>
    <TopMargin>5</TopMargin>
    <BottomMargin>5</BottomMargin>
    <LeftMargin>5</LeftMargin>
    <RightMargin>5</RightMargin>
  </Size>
</ForEsko>
```

The above example created or updated this **Roll Size** in this **Substrate Queue**:

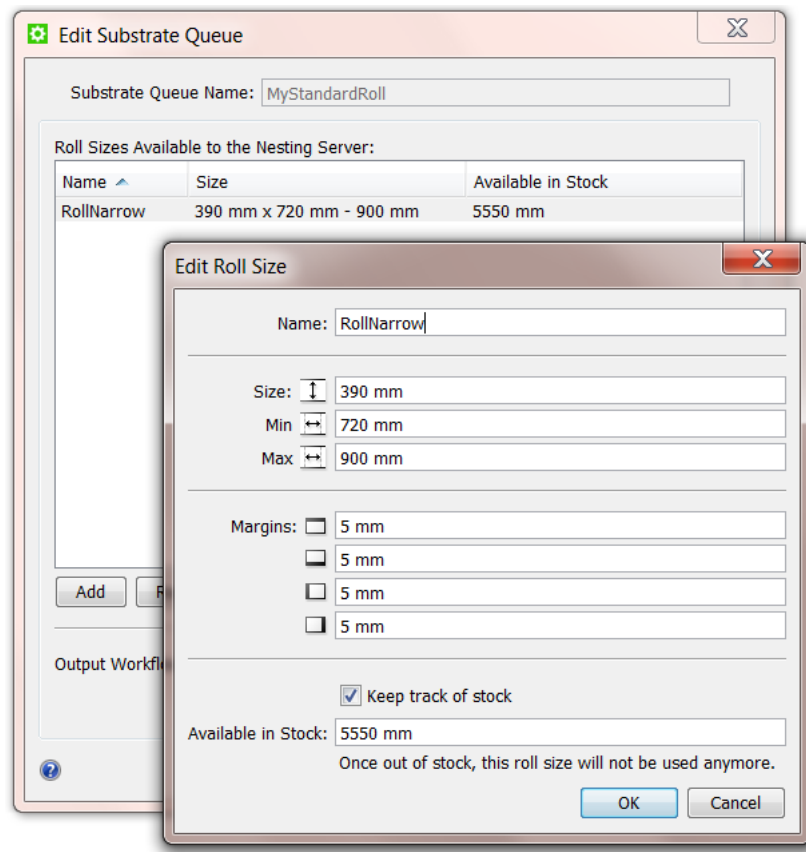

For the **Size Parameter "Use available quantity"** (in this XML described as **<UseAvailableQuantity>**), you can set these values:

- 0 : this disables **Keep track of stock**.
- 1 : this enables **Keep track of stock** (used in above XML example).
- 2 : this deletes the substrate size (for example because all left-over pieces have been used in production).
- 3 : same as value 2.
- 4 : this disables **Keep track of stock** and removes the substrate size if the quantity defined in the XML  $\leq 0$ .
- 5: this enables **Keep track of stock** and removes the substrate size if the quantity defined in the XML  $\leq 0$ .



**Note:** When using the values 4 or 5, the MIS (business system) only needs to pass 1 parameter to manage the stock: the one that maps to **Available quantity**. And when that quantity is  $\leq 0$ , Automation Engine will also remove that substrate size. That way, there is no need for the MIS to explicitly mention the value 2.

So depending on the logic the MIS applies,

- it can either use the value 0 or 1 and at a certain time also use 2 if it wants to remove a substrate size. Automation Engine then does not remove the substrate size unless it is explicitly told so (by that value 2).
- or the MIS can focus on the value of the available quantity and in its XML consistently use the value 4 or 5. When that available quantity reaches  $\leq 0$ , Automation Engine then automatically also removes the substrate size.

### Important Note when you used this task before v 14.1

In Automation Engine v 14.0 this task was named "Import Sheet Sizes from XML". In v 14.1, dedicated support for roll sizes was added and this task was renamed to "**Import Substrate Sizes from XML**".

Also, since v 14.1, the default ticket for the task **Import Substrate Sizes from XML** was adapted: `SheetSize` was renamed to `Size`, `Sheet Name` was renamed to `Name`, `SheetHeight` was renamed to `Height` and `SheetWidth` was renamed to `Width`.

This means that if you used the default ticket in v 14.0, that the default ticket in v 14.1 will generate an error.

To correct this situation, choose one of the following approaches:

- adapt the XML files to make sure they use the new names (advised).
- copy the default ticket to a new ticket, adapt the names to the old names and use this new ticket.

## 14.7.2. Submit to Gang Run (Classic)

Use this task to [submit](#) a graphic file to a [substrate queue](#), where it will be nested with other graphics to optimize substrate usage.

You can also submit ARD files (1-up CAD). This is useful for example when you want to fill a sheet with samples of shapes and send that merged result to a Kongsberg cutting table to cut these samples.

In this task, you can specify parameters (quantity, scale factor...) for nesting graphics based on their cut path.

You can send these file formats to this task:

- TIFF (CMYK or grayscale),
- JPEG (CMYK or grayscale, progressive JPEG compression is not supported),
- PSD (CMYK or grayscale),
- PDF (single page or multi-page),
- Normalized PDF (single page or multi-page),
- ARD files (1-up CAD).

Learn more in:

- [General Tab](#) on page 1013
- [Back Tab](#) on page 1016
- [Substrate Tab](#) on page 1017
- [Extra Tab](#) on page 1017.

### General Tab

1. Define how many of each input graphic you want to print.

You can either:

- Enter the **Quantity** to print.
- Select **Maximum Fill** if you want to print as many copies as will fit in one sheet.

2. Typically, graphics for large banners or billboards are not supplied in the size at which they will be printed out. In this case, you can **Scale** them up here.

For example, enter 1000% if your graphic is only 10% of the size you will need it to be.

3. Define the **Rotation**. This is helpful when all or some of the graphics are only allowed a specific rotation.

You can either:

- Use the rotation that was **Set by the Substrate Queue**.
- **Force a 0, 90, 180 or 270** degrees clockwise rotation. This choice overrules the substrate queue [nesting settings](#).
- **Force Allow Any Angle**: You don't care, you let the software decide. Also this choice overrules the substrate queue [nesting settings](#).
- Select a SmartName.



**Note:** The **Gang Run Printing** view also shows the rotation for each entry in that queue.

4. Define what to use as **Cut Path**.



**Note:** Whereas the [Prepare Graphics for Nesting](#) task allows you to generate a cut path if the graphic doesn't contain one, in the **Submit to Gang Run** task the cut path needs to be already available, either as an ink or by using the trim box as cut path.

If you want to...	do the following...
use an ink as cut path	<p>1. Enter it in the <b>Cut Path</b> field.</p> <div data-bbox="676 1025 738 1090" style="float: left; margin-right: 10px;"></div> <div data-bbox="756 1032 810 1066"><b>Tip:</b></div> <ul style="list-style-type: none"> <li>• If the ink used for the cut path has different names in different input files (for example if you have customers from different countries using names like <i>cut</i>, <i>découpe</i>, <i>taglio</i>...), you can add several ink names, separated by a comma ( , ).</li> </ul> <p>The order you use is important as the task will use the first ink it finds in the list as cut path!</p> <ul style="list-style-type: none"> <li>• You can use wildcards and/or use SmartNames to define ink names. For example use <code>Pantone*</code> if you want to use any Pantone ink used in the file as a cut path.</li> </ul> <div data-bbox="676 1563 738 1628" style="float: left; margin-right: 10px;"></div> <div data-bbox="756 1570 810 1603"><b>Tip:</b></div> <p>When building a workflow using an example file, click  to select one or more of the inks from the example file.</p> <p>If you always receive CMYK graphics with one spot color used for the cut path, select <b>Any SpotColor</b>.</p> <p>2. Define what to do if the ink(s) you defined are not present in the file:</p> <ul style="list-style-type: none"> <li>• If you want to use the trim box as cut path instead, select <b>Create cut path from CAD object or trim box if no ink is found</b>.</li> </ul>

If you want to...	do the following...
	<ul style="list-style-type: none"> <li>If you don't want to use the trim box but want the task to end in error, leave <b>Create cut path from CAD object or trim box if no ink is found</b> deselected.</li> </ul>
use the trim box as cut path	<p>Leave the <b>Cut Path</b> field empty.</p> <p>If you always want to use the trim box as cut path (usually for rectangular graphics like business cards), you don't need to select <b>Create cut path from CAD object or trim box if no ink is found</b> (as this option is only applicable when you want an ink as cut path as your first choice).</p>
gang run ARD files	<p>ARD files can only be submitted when the field <b>Cut Path from Ink</b> is left empty and when the option <b>Create cut path from CAD object or trim box</b> is selected. When this is not the case, the submit task ends in error with the message "Only default cutting path is allowed".</p>

5. If you want to set a due date (when the sheet with the nested graphics needs to be printed), select **Due Date** and choose when you want the due date (and time) to be.

- If you set a due date, the nesting server will always [generate a layout](#) that includes this graphic before your due date, even when the minimum fill has not been reached.



**Tip:** In your substrate queue settings, you can choose to generate the nested layout and send it to the output workflow [a specific time before the due date](#). This allows time for printing, finishing, packing...

- If you don't set a due date, the nesting server will only generate a nested layout when the minimum fill is reached.

Select...	to...
<b>Immediate</b>	generate a nested layout including your graphic immediately (this is the same as when you use <a href="#">Print Now</a> in the <b>Gang Run Printing</b> view).
<b>Today</b>	<p>set the due time to a certain time today (this is the default option).</p> <p>The nesting server will generate a nested layout including your graphic <a href="#">the specified amount of time before the due time</a>.</p>
<b>Tomorrow</b>	<p>set the due date to a certain time tomorrow.</p> <p>The nesting server will generate a nested layout including your graphic the specified amount of time before the due time.</p>
<b>In ... hours</b>	set the due time a certain number of hours after the task is launched (you can set this with a SmartName).

Select...	to...
<b>In ... days</b>	set the due date a certain number of days after the task is launched (you can set this with a SmartName).  You also need to set the due time.
<b>On</b>	set the due date to a specified date (and time) in the future.
<b>Job due date</b>	set the due date to the due date specified in the <b>Job</b> setup (only valid when the graphics are stored in a <b>Job folder</b> ).
<b>Select SmartName...</b>	set the due date using a SmartName.  This opens the <b>SmartNames</b> dialog where you can select your SmartName.  <div data-bbox="596 792 657 855" style="float: left; margin-right: 10px;"></div> <div data-bbox="678 792 1425 1218" style="border: 1px solid #ccc; padding: 10px;"> <p><b>Note:</b></p> <ul style="list-style-type: none"> <li>• See the separate chapter <a href="#">SmartNames</a> for information about SmartNames and how to create custom ones.</li> <li>• Your SmartNames must resolve to a value in the <b>ISO 8601 standard</b> format (for example 2014-09-27T11:08:00+02:00).</li> <li>• If your due dates are supplied in a different format (for example 27/09/14), use the <a href="#">formatting options</a> for date and time SmartNames to convert this format to the ISO standard.</li> </ul> </div>

### Back Tab

- You can here specify what to print on the back of each graphic:

- **No graphics:** Choose this if you don't want any back side for the graphic.
- **Even pages of multi-page file:** Choose this to print the odd pages of the file on the front, and the even pages on the back (this only works with multi-page PDFs).
- **Graphics from front side:** Choose this to print the same graphic on the front and on the back.

If your graphic has an irregular shape, you can select **Flip horizontally** so both graphics face the same direction and have the exact same contour for cutting.



**Note:** If your graphic contains text, you shouldn't flip it as this will make the text unreadable.

- **Other graphics:** choose this to print different graphics on the back, and **Browse** to these graphics.



**Tip:** Give the graphics to print on the back a consistent name, and use SmartNames to retrieve them (for example, [File]\_back.[Extension of File]).

## Substrate Tab

1. Choose the **Substrate Queue** to send your graphics to.



**Attention:**

You should choose (one of) the substrate(s) you have defined as a *substrate queue* in the *Gang Run Printing view*.

If you submit your graphics to a non-existent substrate, a substrate queue will be created automatically for this substrate, but it won't be ready to process your graphics (so your graphics will be stuck in the queue until you *configure it* properly).

2. If this substrate has several sizes defined, you can choose the name of the **Substrate Size** to use. Leave this on **Any** to let Automation Engine find the best fit.



**Attention:** You here define the **Name** of the substrate size as defined in the setup of the substrate queue. Do not enter actual size information here.

## Extra Tab

In this tab you can enter:

1. A **Customer ID** identifying the customer who ordered the graphics. Whether it is also used as a grouping key is one of the settings the *Configure tool*.
2. An **Order ID**: Every graphic file that you here submit with the same Order ID will show up as part of one same order in the *Orders View*. When working with the Job concept, a logic value would be the SmartName [Order ID]. When you don't enter a value, a system-generated ID will be used.
3. Your desired values for the custom fields that you defined in the *Configure tool*.

You can use both customer ID and custom fields either as:

- labels in the *reports* from the nested layouts or the graphics ,
- grouping keys to define *which graphics can be nested together*.

### Example 1: Using Custom Fields as Labels

You get graphics orders from national and international customers. You are using different shipping companies for national and international orders.

When generating layouts, you want to indicate which graphics are for national and for international shipping, so the cutting operator can store the finished graphics in the right places.

1. In the *Configure tool*, define a **Custom Field** as Shipping.  
The corresponding **Custom Field** parameter in this task tab will now be called **Shipping** instead.
2. When launching the task on graphics from international orders, enter *International* in that parameter, otherwise enter *National*.
3. In your *output workflow*, choose to generate a **layout PDF report** in the *Export Gang Run Layouts task*.
4. In the layout report, you will see for each graphic name:
  - the label **National** if the copies of this graphic need to be shipped nationally,
  - the label **International** if the copies of this graphic need to be shipped internationally.

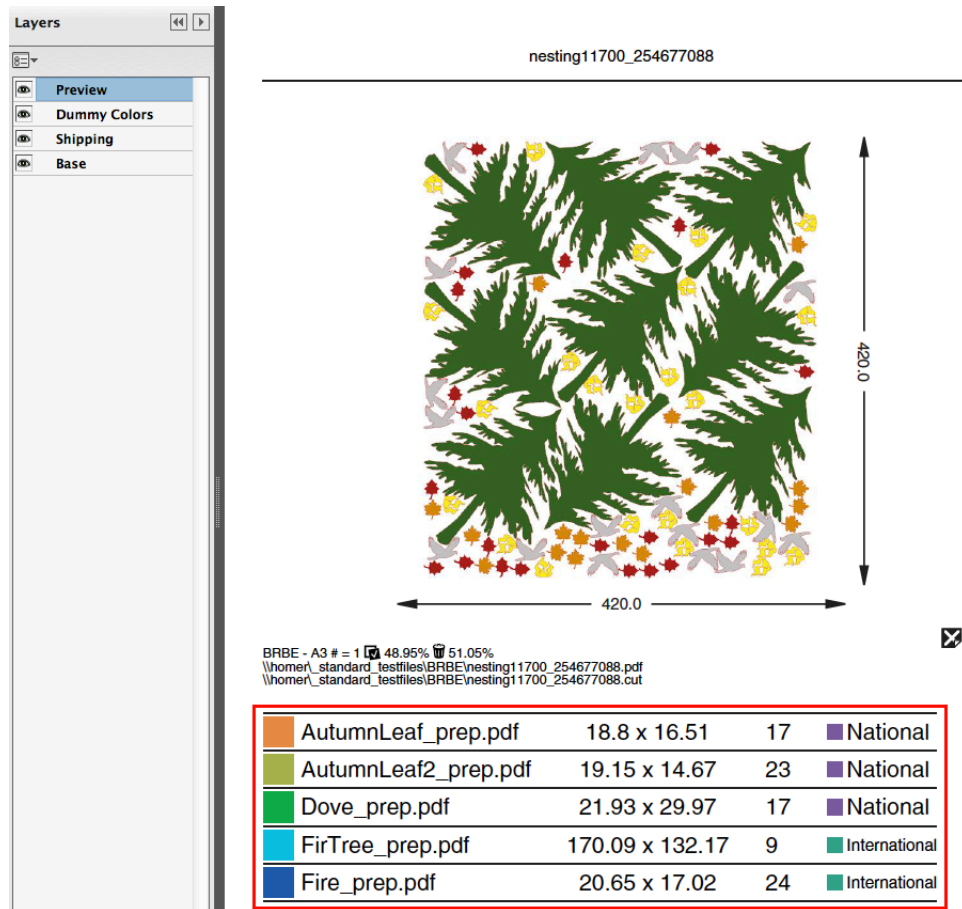

- If you open the report in an application that can show PDF layers (for example Adobe Reader), you will see that the report has a layer called **Shipping**.

If you hide the layers above this layer (so it only shows the layers **Base** and **Shipping**), you will see that:

- graphics that need to be shipped nationally are shown in the color of the **National** label (purple in the example below).
- graphics that need to be shipped internationally are shown in the color of the **International** label (green in the example below, cut paths are shown in red).



Layers

- Preview
- Dummy Colors
- Shipping
- Base

nesting11700\_254677088

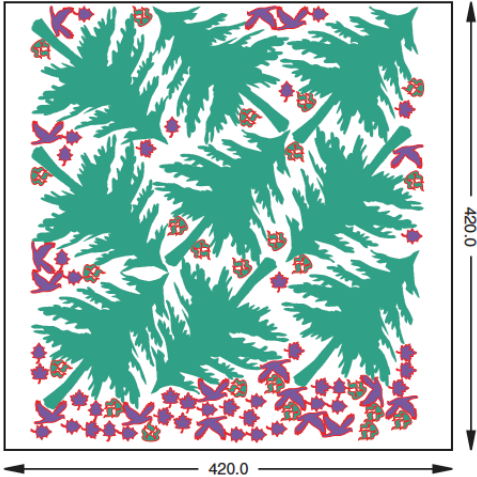

420.0

420.0

BRBE - A3 # = 1 48.95% 51.05%  
 \\homer\_standard\_testfiles\BRBE\nesting11700\_254677088.pdf  
 \\homer\_standard\_testfiles\BRBE\nesting11700\_254677088.cut

AutumnLeaf_prep.pdf	18.8 x 16.51	17	■ National
AutumnLeaf2_prep.pdf	19.15 x 14.67	23	■ National
Dove_prep.pdf	21.93 x 29.97	17	■ National
FirTree_prep.pdf	170.09 x 132.17	9	■ International
Fire_prep.pdf	20.65 x 17.02	24	■ International



**Note:** The way the software chooses the 'random' color for the color patches is identical to how it is done when SmartMarks can use a "random color based on". A specific value (text?) will always return a same color based on that value.

### Example 2: Using Custom Fields as Grouping Keys

You need to print different graphics on the same substrate, but some will need to be laminated and some not.

1. In the *Configure tool*, define a **Custom Field** as `Lamination`, and select **Use as grouping key**.  
The corresponding **Custom Field** parameter in this task tab will now be called **Lamination** instead.
2. When launching the task on graphics to be laminated, enter `Yes` in that parameter, otherwise enter `No`.
3. The nesting server will generate layouts with either:
  - only graphics to be laminated,
  - only graphics that shouldn't be laminated.



**Note:** If you generate a layout report, it will have the label **Yes** if the graphics on that layout need to be laminated, **No** if they don't.

See an elaborate example on using grouping keys and how they show up on reports in [step 10](#) of the below example on [Working with Grouping Keys](#) on page 1058.

### 14.7.3. Submit XML to Gang Run (Classic)

#### Concept

The **Submit XML to Gang Run** task was designed to enable a business system (MIS, ERP...) full interaction with Automation Engine's Gang Run Printing mode.

The business system writes an XML file that serves as the input file of the **Submit XML to Gang Run** task. This XML is minimally a **request** for information about a nesting layout, possibly of a combination of different graphics (known as *ganging*). The MIS can then interpret the detailed **response** XML that it gets back (for example if the waste factor is acceptable). The MIS so decides if and when to re-send that XML file, but now using an extra option to also request links to the actual production files of the nested layout(s).

Let's have a closer look at the two main steps in this process:

- **Request for Nesting information**

To assist with estimating the cost of producing specific jobs, the MIS asks Automation Engine's "Nesting Server" a detailed calculation of a layout of (a batch of) graphics on a specified **Substrate Queue**. The business system wants answers to these questions: How much material will be consumed with this substrate size and this quantity? What will be the waste factor?

**Schema: Nesting Request for estimation purpose only** (*production="FALSE"*)

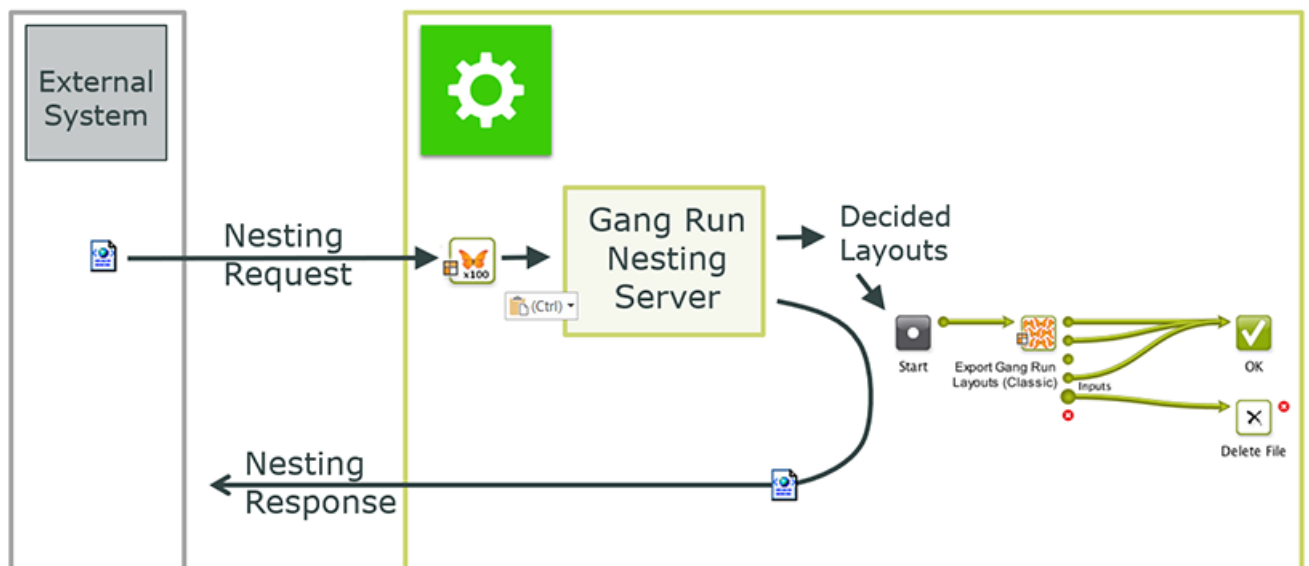

The nesting server calculates and creates the requested layout files and also launches its assigned output workflow. The XML attribute `production="FALSE"` indicates that the response XML can happen immediately, because it does not have to wait for the production files to be created. The MIS interprets the Response XML.

- **Request to Nest and Produce**

When the XML contains the attribute `production="TRUE"`, the response XML will contain links to the production files. To enable this, the response XML is only sent when the workflow that created them has finished.

**Schema: Request for Production** (*production="TRUE"*)

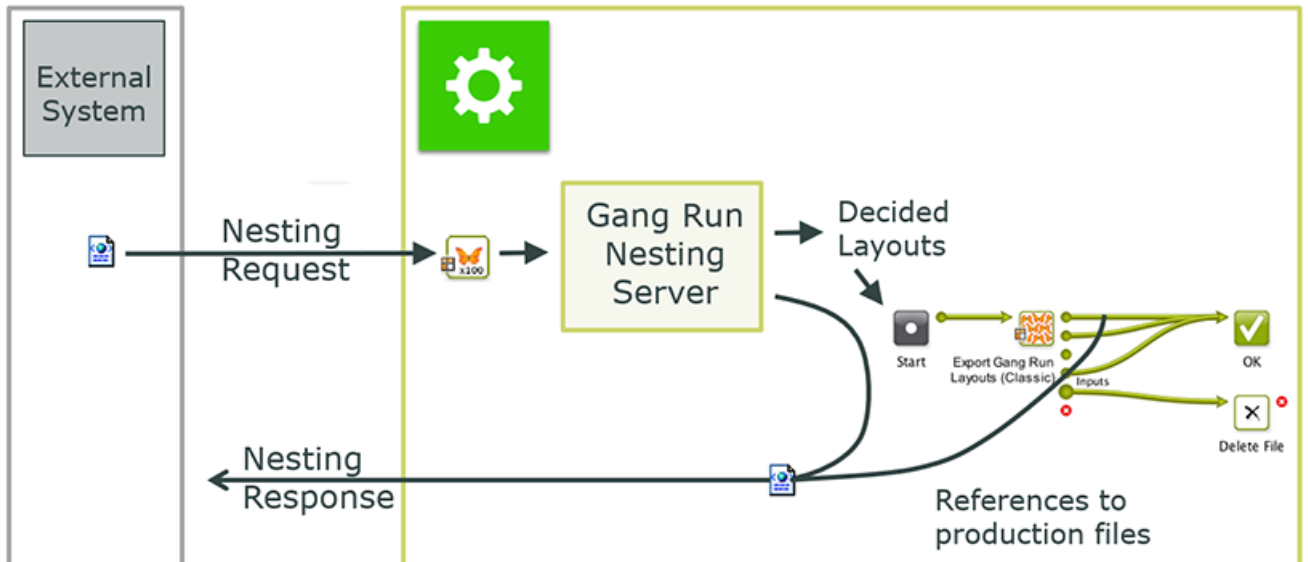

**Using the Submit XML to Gang Run Task**

The task ticket has no interface options. Everything needs to be defined in the input XML file.

As usual, this task can also be triggered by the external system, for example by using a [Folder Access Point](#).

Here is some background on what happens when the task is launched:

- The graphics ("`<jobs>`") listed in the XML enter into the specified Gang Run Substrate Queue(s).
- The "Nesting Server" starts calculating possible layouts. Depending on any specified grouping keys (learn more in [Working with Substrate Queues](#)) it is possible that other graphics that were already present in those substrate queues join the nested layout.
- The nesting server decides and creates an optimized layout.
- When all graphics ("`<jobs>`") for a certain `NestingRequest` have been placed, a `NestingResponse` output XML file is written (on the requested location defined in the input XML file).
- The MIS monitors the URL that it specified as `ReturnURL` and reads the `NestingResponse` XML as soon as it becomes available.



**Note:** As with the [Submit to Gang Run task](#), the "`<jobs>`" listed in the XML can also refer to ARD files.

**Examples of a Nesting Request XML**

**Example Nesting Request for 3 Jobs and 2 Substrates**

In our example, your customer with ID 123456 asks you what it will cost to produce the following items, before noon of 5th of June of 2014:

- 10 items of AmericanCars\_7 on Dibond-4mm, 1100x2400 mm
- 12 items of AmericanCars\_2 on Dibond-4mm, 600x1100 mm
- 12 items of AmericanCars\_1 on Forex-3mm, any size

Your company's sales price will depend on how much it will cost yourself to produce these items. Surely, you want to produce them the most cost-effective way. To get this information, your MIS creates this XML file:

```
<?xml version="1.0" encoding="UTF-8"?>
- <NestingRequest Id="2014-84103">
  <ReturnURL>file://aeserver01/Data1/SnDResponses</ReturnURL>
  <CustomerId>123456</CustomerId>
  <Substrate>Dibond-4mm</Substrate>
  <SubstrateSize>1100x2400</SubstrateSize>
  <Quantity>12</Quantity>
  <DieShape>Cut</DieShape>
  <GroupingKey1>Finishing-Method5</GroupingKey1>
  <GroupingKey4>2014-84103</GroupingKey4>
  <DueDate>2014-06-05T12:00:00+01:00</DueDate>
  - <JOBS>
    - <JOB>
      <FileName>file://aeserver01/Data1/Jobs/SnDJob1/sndprepared/AmericanCars_7.pdf</FileName>
      <Quantity>10</Quantity>
    </JOB>
    - <JOB>
      <FileName>file://aeserver01/Data1/Jobs/SnDJob1/sndprepared/AmericanCars_2.pdf</FileName>
      <SubstrateSize>600x1100</SubstrateSize>
    </JOB>
    - <JOB>
      <FileName>file://aeserver01/Data1/Jobs/SnDJob1/sndprepared/AmericanCars_1.pdf</FileName>
      <Substrate>Forex-3mm</Substrate>
    </JOB>
  </JOBS>
</NestingRequest>
```



**Note:** This example shows that a `NestingRequest` can contain multiple jobs, possibly on multiple substrates, possibly on a specified, a non-specified or on multiple substrate sizes. This allows the XML to describe a production order containing multiple components as 1 `NestingRequest`.

This is a conceptual difference with the [Submit to Gang Run](#) task, which can also report back an XML file but always on 1 single job. The nature of the XML version of this task is the ability to calculate and feedback on batches of jobs.

**Examples with front and back graphics:**



**Attention:** In the 2 below examples, only one `<JOB>` element of the XML is shown:

- **Using the same graphic on the back but flipped:**

```
<JOB>
  <FileName>file://AEServer01/Data1/labels/111_kriek belle vue.pdf</FileName>
  <Quantity>3</Quantity>
  <Scale>100</Scale>
  <DieShape>BORDERS</DieShape>
  <Bleed>2.0</Bleed>
  <SameGraphic>1</SameGraphic>
  <FlipGraphic>1</FlipGraphic>
  <Page number="1"/>
</JOB>
```

The same graphic is used a back-graphic, but will be flipped.

- **Using a specific graphic for the back and filling the sheet:**

```
<JOB>
  <FileName>file://AEServer01/Data1/labels/111_kriek belle vue.pdf</FileName>
  <Quantity>Maximum</Quantity>
  <Scale>100</Scale>
  <DieShape>BORDERS</DieShape>
  <Bleed>2.0</Bleed>
  <BackGraphic>file://AEServer01/Data1/labels/111_kriek belle vue_back.pdf</BackGraphic>
  <Page number="1"/>
</JOB>
```

### Nesting Request for a Roll substrate

There is no difference in the nesting request XML when the substrate is a roll.

## XML documentation

### Technical summary



The **Submit XML to Gang Run** task always outputs a return XML. Its path is specified by the ReturnURL= element in the input NestingRequest XML.

Once the nesting request has been processed fully, the nesting server writes a NestingResponse\_[date].xml file in the specified ReturnURL folder. This response can always be linked to the original request via the id= attribute. The (MIS) system that submitted the NestingRequest should monitor that ReturnURL folder and so pick up the response to its request.

When adding the attribute production="TRUE" to the input XML, the return XML will also include references to the actual production files.

### Documentation of the XML for the Submit XML to Gang Run task

XML Element	Description
NestingRequest (mandatory)	Mandatory root element (max 1). Many sub elements can be specified directly under this element and/or under a sub-element JOB. In the first case they serve as 'global' parameter, in the second as a job-specific one. A job parameter overrules a same type already specified 'globally'.
Id (mandatory)	The Id attribute of the element NestingRequest comes back in the NestingResponse output XML file. Based on this Id, the MIS knows which response matches which request.
ReturnURL	A file:-based URL that specifies the folder where the NestingResponse output XML file will be written once all jobs have been nested.
production="FALSE"	Attribute of the element ReturnURL. Default setting.

XML Element	Description
production="TRUE"	Attribute of the element <code>ReturnURL</code> . As described in <a href="#">Concept</a> , this attribute means that the response XML will wait for the workflow to finish to also add the references to the files produced by the <b>Export Gang Run Layouts</b> task.
DueDate	To be defined in ISO 8601 format.
GroupingKey (n)	Add up to 4 grouping keys to help control groups of nested jobs.  <div style="border: 1px solid #ccc; padding: 5px; background-color: #f9f9f9;">  <b>Tip:</b> Using the <code>NestingRequest Id</code> as grouping key prevents these jobs from being nested with any job that is not part of this request.         </div>
JOBS (mandatory when more than 1 JOB element)	Contains one or more <code>JOB</code> element(s).
JOB (mandatory)	Contains the definition of a graphic. At least 1 <code>JOB</code> element must be present.
FileName (mandatory)	A <code>file:-</code> based URL indicating the one up graphics to be nested. A sub element of a <code>JOB</code> element.
Substrate	The name of the <b>Substrate Queue</b> that will calculate the layout(s).  <div style="border: 1px solid #ccc; padding: 5px; background-color: #f9f9f9;">  <b>Attention:</b> This element can be specified as global setting under the <code>NestingRequest</code> element. When it occurs under a <code>JOB</code> element, it is valid for that job only, and overrules any global values appearing under the <code>NestingRequest</code> element.         </div>
SubstrateSize	The name of the sheet or roll <b>Size</b> of the specified substrate queue. Same remark as for <code>Substrate:</code> can be used as global or job element.
Quantity	Desired quantity for the specified job(s). Same remark as for <code>Substrate:</code> can be used as global or job element.
Rotation	Rotation of the graphic. When not specified, the rotation setting specified in the substrate queue (" <b>nesting settings</b> ") will be used. Possible values are: <ul style="list-style-type: none"> <li><code>sub</code> : use the rotation settings as defined by the substrate queue's nesting settings.</li> <li><code>0</code> or <code>90</code> or <code>180</code> or <code>270</code> : fixed rotation angle (clockwise). This will overrule the rotation setting specified in the substrate queue's nesting settings.</li> <li><code>any</code> : this allows any rotation for the graphic. This will overrule the rotation setting specified in the substrate queue's nesting settings.</li> </ul> Same remark as for <code>Substrate:</code> can be used as global or job element.
Scale	To scale the graphic. Value unit is percentage. No scale = 100. Same remark as for <code>Substrate:</code> can be used as global or job element.
DieShape	The die shape for the graphic. Allowed values: the name of a spot color, the keywords <code>TRIMBOX</code> , <code>BORDERS</code> or <code>DEFAULT</code> .  <code>TRIMBOX</code> (or <code>BORDERS</code> ) will use the trim box of the PDF graphic. <code>DEFAULT</code> will search for a CAD object inside the normalized PDF(STA) file ; if no CAD object is found, the trim box will be used.

XML Element	Description
Bleed	The amount of bleed (in mm) allowed outside the die shape. If no bleed is specified, no bleed mask will be applied, unless the input is a PDFSTA file, in which case the bleed setting from the PDFSTA file will be used.
Page Number	Page selection of the multi-page PDF. Can only be used inside a JOB element.
SameGraphic	Value on 1 means that the (front) graphic defined in FileName will be used as back graphic. Can only be used inside a JOB element.
FlipGraphic	Only valid when value of SameGraphic is on 1. FlipGraphic on 1 defines that the back graphic will be flipped around the vertical axis (mirrored). Mind not to flip graphics that contain text. Can only be used inside a JOB element.
RectoVerso	When the input file is a multi-page PDF, this will use the uneven pages as front pages and the even pages as back pages. This element overrules any use of the elements SameGraphic and FlipGraphic. Can only be used inside a JOB element.
BackGraphic	A file:-based URL indicating the graphic to be used as back graphic. Can only be used inside a JOB element.

### Example of a Nesting Response XML

A NestingResponse XML file contains 2 main elements: Sheets and Jobs.

- The **Sheets** element describes which (part of) sheets were used to nest the given files. It refers to the files by a <Job id=""> element.
- The **Jobs** element lists all jobs that were nested.

The below example shows these 3 sheet elements:

- The first sheet element states, in UsedSheets, that it will take 6 sheets of Forex-3mm 900x900 to deliver the wanted Quantity of 12 AmericanCars\_1. The MIS can calculate that such a sheet places 2 of these graphics. The waste is 0,54 m<sup>2</sup>. The MIS can calculate that this is 11%.
- The second sheet element states, in UsedSheets, that it will take 12 sheets of Dibond-4mm 600x1100 to deliver the wanted Quantity of 12 AmericanCars2. The MIS can calculate that only 1 fits on such a sheet. The waste is 2,56 m<sup>2</sup>. The MIS can calculate that this is 32%.
- The third sheet element states, in UsedSheets, that it will take 2 sheets of Dibond-4mm 1100x2400 to deliver the wanted Quantity of 10 AmericanCars\_7. The MIS can calculate that such a sheet places 5 of these graphics. The waste is 0,82 m<sup>2</sup>. The MIS can calculate that this is 16%.



```

<?xml version="1.0" encoding="UTF-8"?>
- <NestingResponse id="2014-84103" Created="2014-05-20T10:01:06.206+02:00">
  - <Sheets>
    - <Sheet id="419801a2-a743-4628-8119-3abaf1418154" Created="2014-05-20T10:01:00.360+02:00">
      <Substrate>Forex-3mm</Substrate>
      <SubstrateSize>900x900</SubstrateSize>
      - <Jobs>
        - <Job id="adf105b0-ce2d-4fbc-a96e-ae1efa56558e">
          <Quantity>12</Quantity>
          <UsedSheets>6.0</UsedSheets>
          <UsedSurface unit="m2">4.314980209851265</UsedSurface>
          <TotalSurface unit="m2">4.859999999999999</TotalSurface>
          <Waste unit="m2">0.5450197901487349</Waste>
        </Job>
      </Jobs>
    </Sheet>
    - <Sheet id="b802d6f3-31a6-466e-88f3-95e101ae5704" Created="2014-05-20T10:01:06.380+02:00">
      <Substrate>Dibond-4mm</Substrate>
      <SubstrateSize>600x1100</SubstrateSize>
      - <Jobs>
        - <Job id="b6258add-e501-464c-bb85-398e92d88fe6">
          <Quantity>12</Quantity>
          <UsedSheets>12.0</UsedSheets>
          <UsedSurface unit="m2">5.350619541508913</UsedSurface>
          <TotalSurface unit="m2">7.92</TotalSurface>
          <Waste unit="m2">2.569380458491087</Waste>
        </Job>
      </Jobs>
    </Sheet>
    - <Sheet id="f36b931f-4064-4aad-8bed-4b6640332a7e" Created="2014-05-20T10:01:02.166+02:00">
      <Substrate>Dibond-4mm</Substrate>
      <SubstrateSize>1100x2400</SubstrateSize>
      - <Jobs>
        - <Job id="2d05b634-e4a4-4906-97d9-6cc6759d505c">
          <Quantity>10</Quantity>
          <UsedSheets>2.0</UsedSheets>
          <UsedSurface unit="m2">4.458849617924094</UsedSurface>
          <TotalSurface unit="m2">5.279999999999999</TotalSurface>
          <Waste unit="m2">0.8211503820759057</Waste>
        </Job>
      </Jobs>
    </Sheet>
  </Sheets>
  - <Jobs SubmitDate="2014-05-20T10:00:55.654+02:00">
    - <Job id="adf105b0-ce2d-4fbc-a96e-ae1efa56558e">
      <FileName>file://aeserver01/Data1/Jobs/SnDJob1/AmericanCars_1.pdf</FileName>
      <Page>1</Page>
      <Quantity>12</Quantity>
      <Scale>100.0</Scale>
      <DueDate>2014-06-05T12:00:02.626+02:00</DueDate>
      <CustomerId>123456</CustomerId>
      <GroupingKey1>Finishing-Method5</GroupingKey1>
      <GroupingKey4>2014-84103</GroupingKey4>
    </Job>
    - <Job id="b6258add-e501-464c-bb85-398e92d88fe6">
      <FileName>file://aeserver01/Data1/Jobs/SnDJob1/AmericanCars_2.pdf</FileName>
      <Page>1</Page>
      <Quantity>12</Quantity>
      <Scale>100.0</Scale>
      <DueDate>2014-06-05T12:00:02.626+02:00</DueDate>
      <CustomerId>123456</CustomerId>
      <GroupingKey1>Finishing-Method5</GroupingKey1>
      <GroupingKey4>2014-84103</GroupingKey4>
    </Job>
    - <Job id="2d05b634-e4a4-4906-97d9-6cc6759d505c">
      <FileName>file://aeserver01/Data1/Jobs/SnDJob1/AmericanCars_7.pdf</FileName>
      <Page>1</Page>
      <Quantity>10</Quantity>
      <Scale>100.0</Scale>
      <DueDate>2014-06-05T12:00:02.626+02:00</DueDate>
      <CustomerId>123456</CustomerId>
      <GroupingKey1>Finishing-Method5</GroupingKey1>
      <GroupingKey4>2014-84103</GroupingKey4>
    </Job>
  </Jobs>
</NestingResponse>
    
```

### Response XML for a Roll substrate



A response XML for roll substrates is the same as for sheet substrates, except for an extra RollLength element in each Sheet Element.

An example (only one Sheet element is unfolded):

```
<?xml version="1.0" encoding="UTF-8"?>
- <NestingResponse id="26139" ReturnURL="file://AEServer01/Data1/SnDResponses" Created="2015-06-09T12:05:31.795+02:00">
  - <Sheets>
    - <Sheet id="6741c48f-9a23-480f-aa67-30dd294dc802" Created="2015-06-09T12:04:10.132+02:00"
      WorkflowId="9c1ede38-6a93-4d7a-99c6-3e94c64f0098">
        <Substrate>Roll5-1mm</Substrate>
        <SubstrateSize>Large</SubstrateSize>
        <RollLength unit="mm">3829.079</RollLength>
        - <Jobs>
          - <Job id="d4ec0526-8328-4102-819c-0706a0931c1c">
            <Quantity>117</Quantity>
            <UsedSheets>13.0</UsedSheets>
            <UsedSurface unit="m2">33.29332812337053</UsedSurface>
            <TotalSurface unit="m2">46.79134538</TotalSurface>
            <Waste unit="m2">13.498017256629472</Waste>
          </Job>
        </Jobs>
        + <FileList Created="2015-06-09T12:07:28.429+02:00">
        </FileList>
      </Sheet>
    + <Sheet id="87447e2f-3ddc-444e-a59c-4393ca8303c4" Created="2015-06-09T12:04:39.716+02:00"
      WorkflowId="1dd2adc2-2dbf-4b48-82ae-004e9c79ec2c">
    + <Sheet id="e2712b56-1066-419b-b685-bb9a4c69b8dd" Created="2015-06-09T12:04:53.718+02:00">
      WorkflowId="7627556b-9316-4ba0-97e2-03f008d6a613">
    + <Sheet id="a3db2f96-fd1a-44f0-aa7d-8631ffde9a08" Created="2015-06-09T12:05:32.362+02:00"
      WorkflowId="17c836c8-b791-40ae-b633-ca63305b29c8">
    </Sheets>
  + <Jobs SubmitDate="2015-06-09T12:03:29.492+02:00">
  </Jobs>
</NestingResponse>
```

### Example of a Response XML after the Production Workflow

As mentioned earlier, the NestingResponse output XML can be extended to contain references to the actual production files.



**Note:** Production files are the files generated by the **Export Gang Run Layouts** task, as part of the *Output Workflow* of the **Substrate Queue**.

To do this, the MIS must add the attribute production="TRUE" to the ReturnURL element of the NestingRequest XML.

An example:

```
<?xml version="1.0"?>
- <NestingRequest Id="21185">
  <ReturnURL production="TRUE">file://AEServer01/Data1/SnDResponses</ReturnURL>
  ...
</NestingRequest>
```

As a result, each /NestingResponse/Sheets/Sheet element will be extended with a FileList element.

For each production file, there will be a File element attached to the FileList element.

### Example of a NestingResponse XML with references to production files:

```

<?xml version="1.0" encoding="UTF-8"?>
- <NestingResponse id="21185" ReturnURL="file://Aeserver01/Data1/SnDResponses" Created="2014-05-27T11:45:21.191+02:00">
  - <Sheets>
    - <Sheet id="7fdb7110-98a5-4ab5-bc64-676d16aa6a3d" Created="2014-05-27T11:45:21.160+02:00" WorkflowId="035db4f8-a7fe-4c36-b2ec-668dc6a0ba20">
      <Substrate>Dibond-4mm</Substrate>
      <SubstrateSize>600x1100</SubstrateSize>
      - <Jobs>
        - <Job id="86301612-5c10-4b0e-8aa0-489a55237d83">
          <Quantity>12</Quantity>
          <UsedSheets>12.0</UsedSheets>
          <UsedSurface unit="m2">5.350619541508913</UsedSurface>
          <TotalSurface unit="m2">7.92</TotalSurface>
          <Waste unit="m2">2.569380458491087</Waste>
        </Job>
      </Jobs>
      <FileList Created="2014-05-27T11:45:39.563+02:00">
        <File>file://Aeserver01/Data1/SnDoutput/21185/Dibond-4mm/600x1100/nesting17624_265965%201%2012.pdf</File>
        <File>file://Aeserver01/Data1/SnDoutput/21185/Dibond-4mm/600x1100/nesting17624_265965%201%2012_LAYOUT.xml</File>
        <File>file://Aeserver01/Data1/SnDoutput/21185/Dibond-4mm/600x1100/nesting17624_265965%201%2012_LAYOUT.pdf</File>
        <File>file://Aeserver01/Data1/SnDoutput/21185/Dibond-4mm/600x1100/AmericanCars_2.xml</File>
        <File>file://Aeserver01/Data1/SnDoutput/21185/Dibond-4mm/600x1100/nesting17624_265965%201%2012_CUT.pdf</File>
      </FileList>
    </Sheet>
    - <Sheet id="831fdba7-ffdd-4289-a5ba-866fb153c59" Created="2014-05-27T11:45:21.294+02:00" WorkflowId="728ca7ee-c071-482d-8a98-cbd312a78756">
      <Substrate>Dibond-4mm</Substrate>
      <SubstrateSize>900x1100</SubstrateSize>
      - <Jobs>
        - <Job id="f11e2e1c-4d35-4ef8-b357-c99d8ca3b6f5">
          <Quantity>12</Quantity>
          <UsedSheets>6.0492</UsedSheets>
          <UsedSurface unit="m2">4.9683519386757915</UsedSurface>
          <TotalSurface unit="m2">5.989269327278993</TotalSurface>
          <Waste unit="m2">1.020917388603202</Waste>
        </Job>
        - <Job id="43e38513-391d-4388-b911-2eb2abb74ad1">
          <Quantity>12</Quantity>
          <UsedSheets>5.9508</UsedSheets>
          <UsedSurface unit="m2">4.8866099617074426</UsedSurface>
          <TotalSurface unit="m2">5.8907306727210065</TotalSurface>
          <Waste unit="m2">1.004120711013564</Waste>
        </Job>
      </Jobs>
      <FileList Created="2014-05-27T11:45:39.563+02:00">
        <File>file://Aeserver01/Data1/SnDoutput/21185/Dibond-4mm/900x1100/nesting17624_265965%202%2012.pdf</File>
        <File>file://Aeserver01/Data1/SnDoutput/21185/Dibond-4mm/900x1100/nesting17624_265965%202%2012_LAYOUT.xml</File>
        <File>file://Aeserver01/Data1/SnDoutput/21185/Dibond-4mm/900x1100/nesting17624_265965%202%2012_LAYOUT.pdf</File>
        <File>file://Aeserver01/Data1/SnDoutput/21185/Dibond-4mm/900x1100/AmericanCars_3.xml</File>
        <File>file://Aeserver01/Data1/SnDoutput/21185/Dibond-4mm/900x1100/AmericanCars_4.xml</File>
        <File>file://Aeserver01/Data1/SnDoutput/21185/Dibond-4mm/900x1100/nesting17624_265965%202%2012_CUT.pdf</File>
      </FileList>
    </Sheet>
  </Jobs SubmitDate="2014-05-27T11:45:13.094+02:00">
    - <Job id="86301612-5c10-4b0e-8aa0-489a55237d83">
      <FileName>file://Aeserver01/Data1/SnDFiles/AmericanCars_2.pdf</FileName>
      <Page>1</Page>
      <Quantity>12</Quantity>
      <Scale>100.0</Scale>
      <DueDate>2014-05-27T11:45:21.206+02:00</DueDate>
      <CustomerId>123456</CustomerId>
      <GroupingKey4>21185</GroupingKey4>
    </Job>
    - <Job id="f11e2e1c-4d35-4ef8-b357-c99d8ca3b6f5">
      <FileName>file://Aeserver01/Data1/SnDFiles/AmericanCars_4.pdf</FileName>
      <Page>1</Page>
      <Quantity>12</Quantity>
      <Scale>100.0</Scale>
      <DueDate>2014-05-27T11:45:21.206+02:00</DueDate>
      <CustomerId>123456</CustomerId>
      <GroupingKey4>21185</GroupingKey4>
    </Job>
    - <Job id="43e38513-391d-4388-b911-2eb2abb74ad1">
      <FileName>file://Aeserver01/Data1/SnDFiles/AmericanCars_3.pdf</FileName>
      <Page>1</Page>
      <Quantity>12</Quantity>
      <Scale>100.0</Scale>
      <DueDate>2014-05-27T11:45:21.206+02:00</DueDate>
      <CustomerId>123456</CustomerId>
      <GroupingKey4>21185</GroupingKey4>
    </Job>
  </Jobs>
</NestingResponse>
    
```

## Using Workflow Parameters in this Process

### Concept

Having these production files created on specific folders and with specific names will be important for the MIS to recognize and read them.

You can organize the production files that were created by a `NestingRequest` by using some **workflow parameters** that are available in the workflow that was launched on the generated Nested Layout files. See an example below where we picked some from the list of SmartNames.

Also the **Grouping Key**'s and custom fields used in the *Submit to gang Run* task can be used to help determine names of folders and files. Note that these only appear in the list of SmartNames after you first used that workflow ticket.

**Example**

- In *Pilot > Configure > Gang Run Printing*, we renamed the customfield 4 to OrderId and confirmed that we want to use this field as a grouping key.
- In the **Export Gang Run Layouts** ticket of the workflow that the substrate queue launches on the generated nested layouts, set up the **Output Folder** for the *Production Files* as in this example:

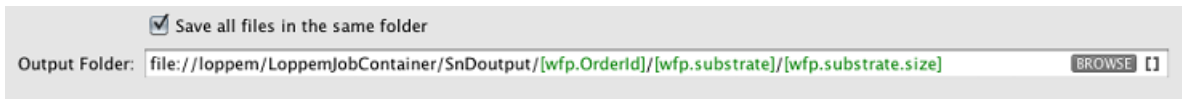

**Note:** Learn more about these SmartNames in [this page about the 'Export Gang Run Layouts' task](#).

- As a result, the production files are organized in a folder structure that makes it easy for the MIS to find the files related to its initial NestingRequest:

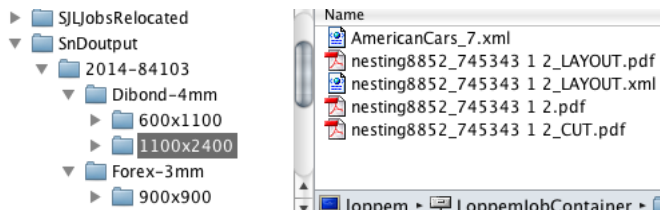

**Workflow Extensions**

**Concept**

Production files that are mentioned in the `NestingResponse` output XML can then be picked up again in an Automation Engine workflow for further processing. You can use the workflow control *Select Referenced File* to do this.

**Example workflow**

This enables a lot of extensions to the workflow. In this example we select the production files and ZIP them before sending them to an external system or partner. You can also choose to delete those files locally.

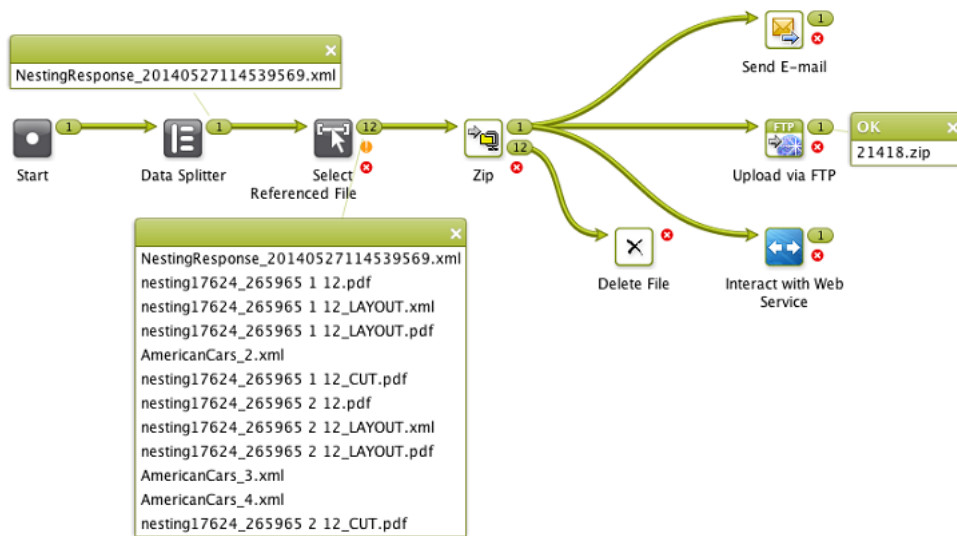

### 14.7.4. Export Gang Run Layouts (Classic)



**Note:** Before AE 22.03, this task was named 'Export Nested Layouts'.

Use this task to create production files (a PDF print file and a cutting file) from your nested Gang Run Printing layouts.

Typically, this task is the main step of your Gang Run Printing **output workflow**.

When working with Gang Run Printing:

1. You submit the graphics to be nested and printed through the *input workflow*.
2. The *nesting server* automatically nests the graphics on the substrate, and sends the resulting nested layouts to the output workflow *that is linked to that substrate queue*.
3. The *output workflow* generates production files from the nested layouts.



**Note:** In a workflow, this task has five output pins: **Print Files**, **Cutting Files**, **Offcuts**, **Inputs** and **Error**. This makes it easy to redirect each type of file to the right place.

If you ask to **Create Reports**, the task will show an extra output pin for these report files.



**Attention:** The output pin **Offcuts** requires an 'Export Gang Run Layouts' ticket from AE v18.1.1 or later. To see the 'offcuts' pin on workflow tickets that you made sooner, just open and close that ticket to make this pin appear.

Learn more in:

- [Production Files Tab](#) on page 1031
- [Sheet Tab](#) on page 1033
- [Reports Tab](#) on page 1036.

#### Managing the exported Layout PDFPLA files

The layouts that the nesting server creates are written as PDFPLA files on a central folder. By default, this folder is **ExampleJobContainer/SnDtemp**. To optimize data traffic, we advise to have this folder on a disk away from your system drive. You can change this folder *in the configure panel*.

These PDFPLA files are not cleaned up automatically. We advise to build this cleanup into your output workflow. This is easily done as in below example, where you delete this PDFPLA input file that arrives on the "Inputs" output pin:

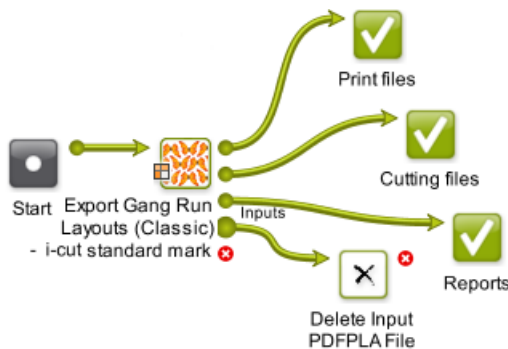

### Production Files Tab

The task will output:

- **PDF print files** that are to be printed. When the input PDFPLA file only contains CAD data (you only submitted ARD files to the Gang Run), the option **Save Print Files** is skipped.
- **Cutting files**. These are used by cutting tables to print the printed sheet or roll. There are many formats available.



**Note:** Every resulting layout is a single page PDF print file, unless you are printing front and back (in which case the back graphic(s) will be on a second page).

1. In **Save Cutting Files**, choose the cutting file format you want to generate (**i-cut**, **HPGL**, **PDF**, **MFG**, **ACM** or **JDF** for *Kongsberg cutting tables* or **JDF** for guillotine cutters).



**Tip:**

- If you have several cutting tables and you don't know yet which one you will use, you can generate several file formats: choose **Select File Types...**, select all the file types you want to generate and click **OK**.
- If you want to check your cutting files for quality control, you can also output a PDF file and inspect it in Acrobat.

When generating an **ACM** file (for a Kongsberg table), you can select **Print Side Up** to cut with the print side visible.

For all cutting file types except **JDF**, you can influence the knife or cutting head's cutting sequence:

- Leave **Sequence lines** deselected if you want to use the original cut paths for the cutting lines (this way, common lines between graphics are only cut once, but every graphic is still cut individually).

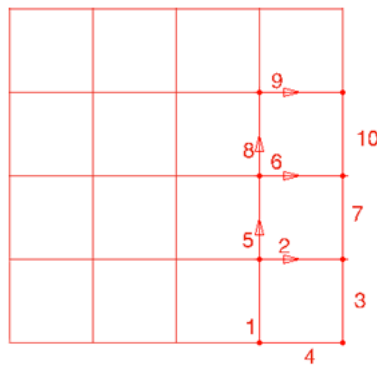

- Select **Sequence lines** if you want the vertical and horizontal cutting lines to be concatenated so that the knife can cut longer lines at once (the cutting process is faster when the knife doesn't need to be lifted and brought down, and accelerate and decelerate many times).

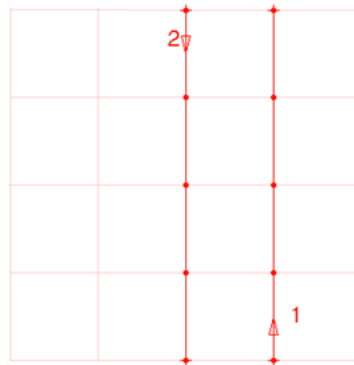

If you selected **Sequence lines**, you can choose to **Cut Across Gaps** to cut longer lines at once even if there is a *gutter* between your graphics.



**Attention:**

When you export an **i-cut** file, make sure you have **i-cut marks** in your file as they are needed to define where to start cutting.

Other SmartMarks in your file will not be used for that purpose when working with an i-cut file.

Learn more about i-cut marks in the [i-cut Layout manual](#).



**Note:** When the PDFPLA only contains CAD data (you only submitted ARD files to the Gang Run), then all structural lines get exported when choosing MFG or ACM (using the default ArtiosCAD sample making output). With all the other cutting formats, only the cut and crease lines get exported.

2. By default, all inks with the ink type "technical", including the ink used for the cut path, are considered structural inks, and are included in the cutting file but not in the print file.

If you want to include other inks from your graphic in the cutting file but not in the print file, enter their names in **Add Extra Structural Inks**.

When adding several inks, you should separate their names with a comma, for example *Crease, Kiss-cut*. You can also use wildcards (\*) and SmartNames.

3. If you want to give your output files a specific name, enter it in **Output Name**. By default, the output files have an automatically generated name containing unique identifiers. The default ticket proposes you to use smart workflow parameters. It also proposes to end the name with a unique ID like **[ Short Task ID ]**. This will prevent that output files overwrite each other (which can happen for example when several layouts are generated):

Output Name:

**Table: Meaning of SmartNames useful in this workflow:**

SmartName (wfp)	meaning
substrate	This is the name of the substrate queue.
substrate.size	This is the name of the sheet (or roll) size.
substrate.size.quantity	This is the number of times the nested layout needs to be printed in order to get to the requested quantity of the submitted graphics.
substrate.size.type	This is the substrate type: Sheet (value P for plano) or Roll (value R).
customer.id	Mind that this one will only appear when you selected the option <b>Use the Customer field as grouping key</b> in the <a href="#">Configure tool</a> . This is the one you used as 'CustomerId' in the <a href="#">Submit to Gang Run task (tab 'Extra')</a> .



**Note:** When multiple copies of the same layout need to be printed, the number of copies will automatically be added to the PDF file name.

4. Define where to save the production files and the report(s):
  - If you want to save all output files in the same folder, select **Save all files in the same folder**, and browse to that **Output Folder**.
  - Otherwise, deselect **Save all files in the same folder** and browse to your specific folder for the **Print Files, Cutting Files** and **Report Files**.

When you didn't specify an output folder, the files are by default written in `\ExampleJobContainer\SnDTemp`.

### Sheet Tab

1. If you want, you can add **SmartMarks** to the nested layout (a SmartMarks set that you created in i-cut Layout or PackEdge).

You can for example use a SmartMarks set containing registration and/or cut marks. You can use SmartNames to enter your SmartMarks set's name.

- When the *nesting server* generates a nested layout, it places the layout on the sheet based on the settings of the substrate queue (*sheet size and margins* and *nesting settings*).

However, for printing and finishing purposes, you may want to reposition the nested layout on the sheet. In **Center Layout on Sheet** you can choose to center the layout either **Vertically**, **Horizontally**, or **Vertically and Horizontally**.

In the example below, the nested layout (left) has been centered both vertically and horizontally (right).

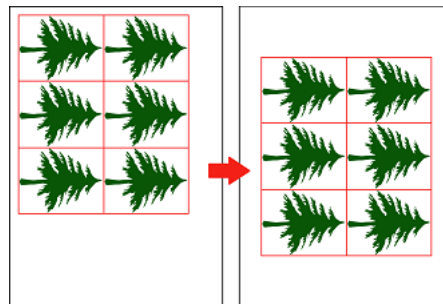

**Attention:** The option is ignored when an offcut area has been found. Learn about offcuts in the [page about offcuts](#) (part of the nesting settings of a (sheet) substrate queue).

- If you are working with substrate rolls or large sheets, you can choose to fit the final PDF that will be printed (the "sheet" file containing your nested layout) to one or both of the layout's dimensions.

This way, you can cut closer to the layout and have less substrate waste (for rolls) or save the remaining blank area as an offcut so you can reuse it (for large sheets).

For **Fit Sheet**, choose either:

- To Layout Height** to fit the sheet height to the height of your nested layout.

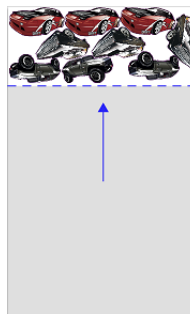

- To Layout Width** to fit the sheet width to the width of your nested layout.



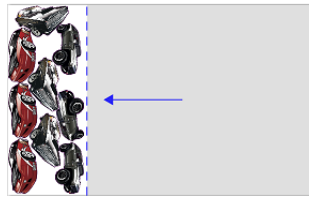

- **To Layout Width & Height** to fit the sheet height and width to the height and width of your nested layout.

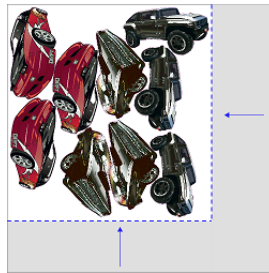

**Note:** When using the option **Fit Sheet**, no *offcuts* will be generated.

4. If you are printing front and back, define how the sheet will be turned in **Backing Up**: either **Work-and-Turn** or **Work-and-Tumble**.

This influences how the back graphics will be placed in your final PDF.

Front (at left) and back (at right) with **Work-and-Turn**:



Front and back with **Work-and-Tumble**:



## Reports Tab

Reports can help production and finishing and can also serve as feedback to your business system.

### XML Reports

- Select **For every layout** if you want an XML report describing the layout: its size and substrate, its waste, the graphics used, their quantity, cut files, URLs, etc.
- Select **For every graphic** if you want an XML report of each graphic used in that layout. This file describes the layout that this graphic was used in, how many times it was used, remaining quantity, etc.

### Example of XML Report of a Layout:

```
<?xml version="1.0" encoding="UTF-8" ?>
- <LAYOUT>
  <CUTFILE>\\eaw11dl306\WDE-AE-DATA\GRP_output\155040_Alucomp 8 mm_CUT.pdf</CUTFILE>
  <CUTFILE>\\eaw11dl306\WDE-AE-DATA\GRP_output\155040_Alucomp 8 mm.cut</CUTFILE>
  <PDFFILE>\\eaw11dl306\WDE-AE-DATA\GRP_output\155040_Alucomp 8 mm.pdf</PDFFILE>
  <TotalLength number="63233.79" />
  <WIDTH number="2468.619" />
  <HEIGHT number="1216.476" />
  <COPIES number="1" />
  <SUBSTRATE>Alucomp 8 mm</SUBSTRATE>
  <YIELD number="1751767.0" />
- <JOBS>
+ <JOB>
+ <JOB>
- <JOB>
  <JOBNAME>fiona_Prep.pdf</JOBNAME>
  <NUMBERUP>7</NUMBERUP>
  <REMAINING>13</REMAINING>
  <VSIZE>325.2</VSIZE>
  <HSIZE>140.38</HSIZE>
- <POSITIONS>
  - <POSITION>
    <V>330.69</V>
    <H>2013.52</H>
    <SCALE>1.0</SCALE>
    <ANGLE>90.0</ANGLE>
  </POSITION>
  + <POSITION>
  + <POSITION>
  + <POSITION>
  + <POSITION>
  + <POSITION>
  + <POSITION>
  + <POSITION>
  </POSITIONS>
  <CustomerId />
  <ExtId>182534fa-ce67-4745-bc65-f2ba7e71a507</ExtId>
  <Folder>\\eaw11dl306\WDE-AE-DATA\GRP_output\GRP_Prep</Folder>
  <ForceOut>Y</ForceOut>
  <GroupingKey1>LamNo</GroupingKey1>
  <GroupingKey2 />
  <GroupingKey3 />
  <GroupingKey4 />
  <Id>ebb93a7e-ec0c-4cbb-b62c-1bbd75633e56</Id>
  <PageCount number="1" />
  <PageNr number="1" />
  <Rotation>sub</Rotation>
  <Substrate>Alucomp 8 mm</Substrate>
  <SubstrateSize>2500x1250</SubstrateSize>
  </JOB>
+ <JOB>
+ <JOB>
</JOBS>
</LAYOUT>
```

Table: Clarification of above XML Report of a Layout

Part of Element	Element	Meaning
LAYOUT	<b>TotalLength</b>	In mm, the total length of the cut path. This enables to get an idea how long a cutting table would take to cut this path.
LAYOUT	<b>COPIES</b>	The amount of times that this layout will need to be printed (as calculated by the nesting server).
LAYOUT	<b>YIELD</b>	The surface of the area within the cut path(s) of the graphic(s), expressed in square mm.

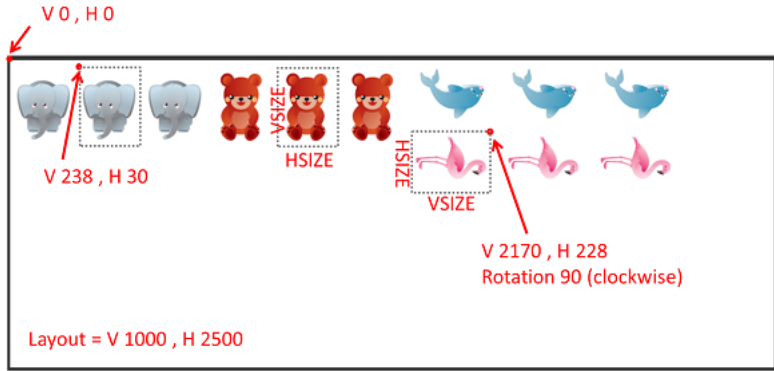
Part of Element	Element	Meaning
LAYOUT	<b>YIELDPCT</b>	The surface of the area within the cut path(s) of the graphic(s), expressed in percentage of the total sheet surface.
LAYOUT	<b>WASTE</b>	The surface outside the cut path(s) of the graphic(s), expressed in square mm.
LAYOUT	<b>WASTEPC</b>	The surface outside the cut path(s) of the graphic(s), expressed in percentage of the total sheet surface.
JOB	<b>NUMBERUP</b>	Amount of times this <JOB> (graphic) is present on this layout.
JOB	<b>REMAINING</b>	Amount of times this <JOB> (graphic) still needs to be printed to produce the requested amount.
JOB	<b>VSIZE</b> and <b>HSIZE</b>	In mm, V and H size of surface that this <JOB> (graphic) occupies on this layout (bounding box), before any rotation. See also below illustration.
POSITION	<b>V</b> and <b>H</b>	In mm, V and H position of this <JOB> (graphic), calculated from the top left of the bounding box of the graphic to the top left of the layout. See this example (to keep the overview, all cut paths were based on the graphic's trim box and not on 'white background'):  
JOB	<b>Folder</b>	URL of file that was submitted to the nesting server. This is typically the output file of the <b>Prepare Graphics for Nesting</b> task.
JOB	<b>ExtId</b>	Esko internal ID, not useful to non-Esko systems.
JOB	<b>ForceOut</b>	<b>Y</b> indicates that this layout was made after someone used the <b>Print now</b> button or after a deadline was reached. This element is not present when the layout was made because the nesting server reached a minimum fill.
JOB	<b>Id</b>	Esko internal ID, not useful to non-Esko systems.
JOB	<b>PageCount</b>	Total number of pages of the file in <b>JOBNAME</b> .
JOB	<b>PageNr</b>	Number of page of file in <b>JOBNAME</b> that was placed on this layout.
JOB	<b>Rotation</b>	Rotation of this graphic as it was set in the <a href="#">Submit to Gang Run</a> task. <b>Sub</b> means " <b>Set by Substrate Queue</b> ", <b>Any</b> means " <b>Force Allow Any Angle</b> " and <b>0, 90, 180</b> or <b>270</b> (clockwise) means those specific angles were decided there. See in above illustration how the rotation is done using the top left corner as axis.
JOB	<b>Substrate</b>	Name of the substrate queue that this layout was made for.

Part of Element	Element	Meaning
JOB	<b>SubstrateSize</b>	Mind that this is the <b>name</b> of the substrate size as defined for that substrate queue.

**Example of XML Report of a Single Graphic:**

```

<?xml version="1.0" encoding="UTF-8" ?>
- <JOB>
  <Quantity>13</Quantity>
  <FileName>\\eaw11dl306\WDE-AE-DATA\GRP_output\GRP_Prep\fiona_Prep.pdf</FileName>
  <Scale>100.0</Scale>
  <DieShape>CUT</DieShape>
  <Bleed>2.0</Bleed>
- <Layouts>
  <CUTFILE>\\eaw11dl306\WDE-AE-DATA\GRP_output\155040_Alucomp 8 mm.cut</CUTFILE>
  <PDFFILE>\\eaw11dl306\WDE-AE-DATA\GRP_output\155040_Alucomp 8 mm.pdf</PDFFILE>
  <WIDTH number="2468.619" />
  <HEIGHT number="1216.476" />
  <COPIES number="1" />
  <NUMBERUP number="7" />
</Layouts>
  <CustomerId />
  <ExtId>182534fa-ce67-4745-bc65-f2ba7e71a507</ExtId>
  <Folder>\\eaw11dl306\WDE-AE-DATA\GRP_output\GRP_Prep</Folder>
  <ForceOut>Y</ForceOut>
  <GroupingKey1>LamNo</GroupingKey1>
  <GroupingKey2 />
  <GroupingKey3 />
  <GroupingKey4 />
  <Id>ebb93a7e-ec0c-4cbb-b62c-1bbd75633e56</Id>
  <PageCount number="1" />
  <PageNr number="1" />
  <Rotation>sub</Rotation>
  <Substrate>Alucomp 8 mm</Substrate>
  <SubstrateSize>2500x1250</SubstrateSize>
</JOB>

```

In addition to above table for the XML report for layout, this table shows specifics for the XML report of a single graphic:

**Table: Clarification of above XML Report of a Single Graphic**

Part of Element	Element	Meaning
JOB	<b>Quantity</b>	Remaining quantity for the nesting server to put on other layouts to reach the requested amount for this graphic.
JOB	<b>DieShape</b>	Name of the cut path as defined in the <a href="#">Submit to Gang Run</a> task.
JOB	<b>Bleed</b>	Maximum bleed for this graphic. This value is the one set as <b>Bleed Clipping Mask</b> in the nesting settings of the substrate queue.
Layouts	<b>COPIES</b>	The amount of times that his layout will need to be printed (as calculated by the nesting server).
Layouts	<b>NUMBERUP</b>	The amount of times this graphic is placed on this layout.

Part of Element	Element	Meaning
JOB	<b>ExtId</b>	Esko internal ID, not useful to non-Esko systems.
JOB	<b>ForceOut</b>	<b>Y</b> indicates that this layout was made after someone used the <b>Print now</b> button or after a deadline was reached. This element is not present when the layout was made because the nesting server reached a minimum fill.
JOB	<b>Id</b>	Esko internal ID, not useful to non-Esko systems.
JOB	<b>PageCount</b>	Total number of pages of the file in <b>FileName</b> .
JOB	<b>PageNr</b>	Number of page of file in <b>FileName</b> that was placed on this layout.
JOB	<b>Rotation</b>	The value indicates the rotation of this graphic as it was set in the <a href="#">Submit to Gang Run</a> task. <b>Sub</b> means " <b>Set by Substrate Queue</b> ", <b>Any</b> means " <b>Force Allow Any Angle</b> " and <b>0, 90, 180</b> or <b>270</b> means those specific angles were decided there.

### PDF Report

A PDF report can be made **For every layout**. Such a report is typically used as instruction for the cutting table operator.

The template of this PDF is fixed, but you can define:

- the **Report Size (A4 or Letter)**,
- the **Report Resolution** used for the graphics preview in the report (in **ppi**),
- the **Units** used in the report (**mm** or **inch**).

An example:



173707\_PVC

PVC - 2500x1250mm # = 1  76.01%  23.99%

\\eaw11dl306\WDE-AE-DATA\GRP\_output\173707\_PVC.pdf  
 \\eaw11dl306\WDE-AE-DATA\GRP\_output\173707\$PVC.pdf  
 \\eaw11dl306\WDE-AE-DATA\GRP\_output\173707\$PVCT.cut

	Stevens_Dog_LamNo_100_Prep.pdf	185.34 x 185.42	12/12		Stevens		LamNo
	Stevens_Dog_LamNo_100_Prep.pdf	185.34 x 185.42	76		Stevens		LamNo

A PDF report shows following information:

- (on top) name of the layout and, when not 1, the amount of copies this layout needs to be printed.
- preview and size of the layout
- an area with text:
  - the first line mentions this information: name\_of\_substrate,name\_of\_substrate\_size, # = amount\_of\_copies\_this\_layout\_needs\_to\_be\_printed,  used\_material %,  wasted\_material %
  - URLs to the print and cut file(s).
- below right, a thumbnail showing the back graphics (☞). When there are no back graphics, a  icon is shown instead.
- a list of the graphics on this layout. Per graphic:
  - a patch with an arbitrary chosen color that is also used in the PDF layer "Dummy Colors" (learn more below),
  - name and size of the graphic file on the layout,
  - amount of times the graphic is placed on this layout / total requested amount. When **maximum fill** was chosen, only the amount in this layout is shown.

- (when used) custom labels: their name and a patch with an arbitrary chosen color. See further below to learn how hiding PDF layers visualises which graphics have these labels.

### Layers in Layout Reports

When graphics look much alike, it can be helpful to not see the preview but see dummy colors in stead. This makes it much easier to see which one is placed where. An example:

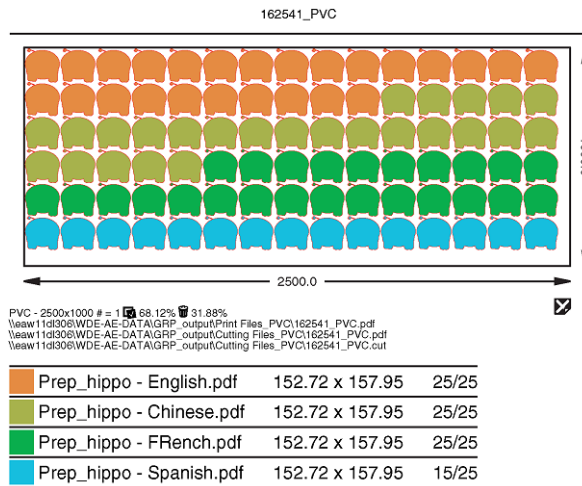

In these PDF reports, the preview of the graphics is a separate layer. You can see or hide layers by switching them on or off in Acrobat. You can also have your workflow create extra versions of this report by removing the preview layer for example. See such a workflow in [this step of one of the examples at the end of this chapter](#).

Also the custom labels are shown in a separate layer (learn about custom labels in [Overview of Substrate Queue Entries](#) on page 1000). See this report example in Adobe Acrobat of a layout containing graphics with two custom labels, one for finishing (need for lamination) and one for shipping (type of transport). Only the **Base** layer and the **Transport** layer are shown:

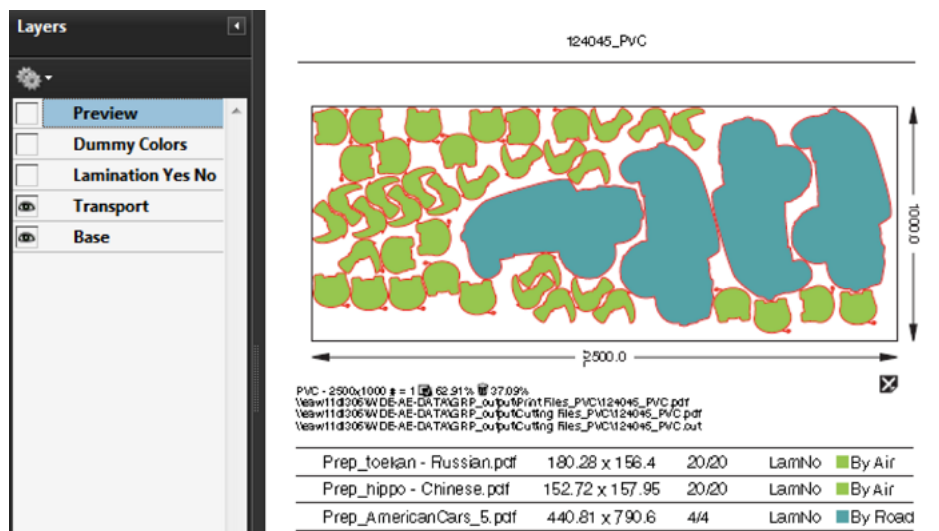



By hiding some layers, it quickly becomes visible which graphics need their transport by air and which ones by road. This quick visual helps your colleagues in the packing and shipping.

See more examples of PDF reports in [Step 10](#) of the example on [Working with Grouping Keys](#) on page 1058.

## 14.8. Automating your Workflow Using XML

The use of XML enables many ways to integrate Automation Engine's Gang Run Printing mode with an external system, typically the system that manages orders, production details and stock.

This bidirectional communication via XML results in a high form of automation.

We can distinguish a basic and an advanced level of such integration:

- **Basic use of XML in Gang Run Printing**

### Schema: Using XML in GRP (basic use)

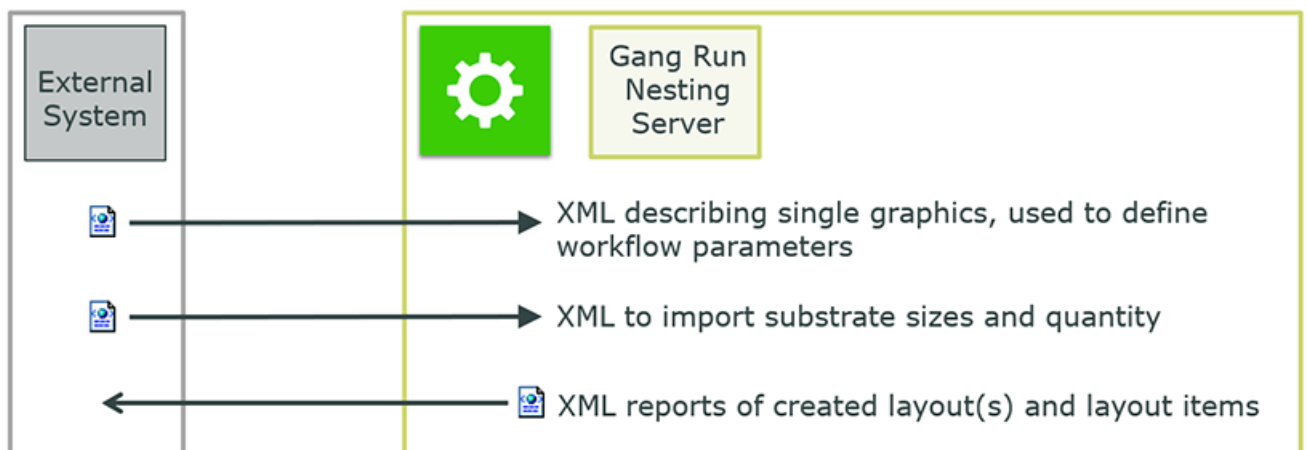

- An XML file describing a job is sent to Automation Engine (typically a Folder Access Point). The XML informs the workflow of the name of the graphic file (only one per XML) and also what to do with it (substrate, quantity, etc.). This is illustrated in detail in the example [Basic XML driven workflow](#) on page 1070.



**Note:** These XML files can be very simple and serve a workflow where you mostly get orders for copies of one graphic at a time. See the below 'advanced' section to read about more complex XML files that ask the nesting server to calculate layouts for a list of files.

- A dedicated task uses an XML file to update the list of the available substrate sizes and also of their current quantity in stock. Learn more in [Import Gang Run Substrate Sizes from XML](#) on page 1008.
- The task that exports the nested layouts into print and cut files also writes report files. You can choose to have them in XML form, so that an external system can use them for production

status (how many were already nested?) or for post-production cost-calculation (material usage/waste). Learn more in [Export Gang Run Layouts \(Classic\)](#) on page 1030.

- **Using XML for Advanced Communication with the Nesting Server**

The dedicated [Submit XML to Gang Run](#) task enables these advanced forms of XML based communication:

- The business system sends XML files that represent 'nesting requests', possibly of complex orders. They can be about different graphics, each with their own quantity, substrate, etc. By doing this, the business system can ask the nesting server possible layouts for estimation purpose only. It then uses the return data for its own cost calculation and maybe production preparation.
- After the layouts have been exported, the feedback XML to the business system describes the whole order and includes references to the actual production files.

Here 's a schema about this workflow:

**Schema: Request for Production** (*production="TRUE"*)

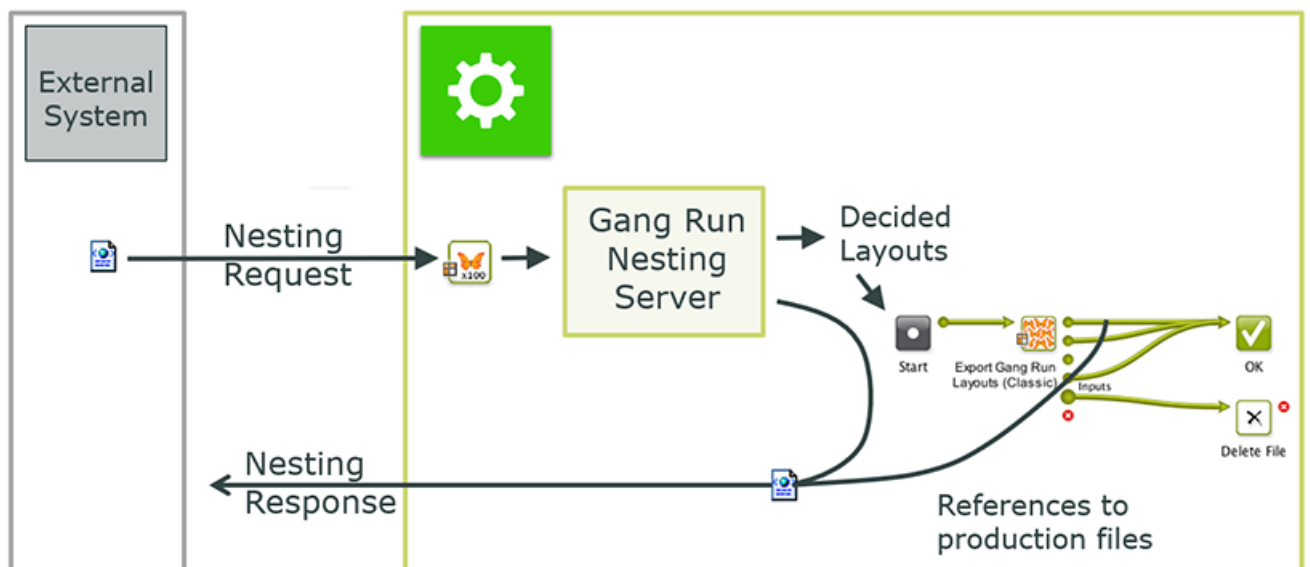

The XML files that the business system sends must match a [detailed specification](#).

Learn more in [Submit XML to Gang Run \(Classic\)](#) on page 1020.

## 14.9. The Orders View

### Concept

This view is targeted to customer service people or production floor managers who want to track orders that used the Gang Run mode and that then (typically after printing) will be produced on a Kongsberg cutting table.



**Note:** Learn more about using Automation Engine to manage your production on a Kongsberg table in the chapter [Kongsberg Production Workflow](#) on page 1565.

All information in this view is updated live. It shows the status of all parts of a job **Order** that was processed by a *Gang Run queue*. It helps to monitor orders, especially those where multiple graphics need to be printed and cut.

This workflow and View is also valid when you *submit ARD or MFG CAD files to a Gang Run queue*. For sake of convenience, this view describes both graphics or ARD / MFG input files as '**One-Ups**'.

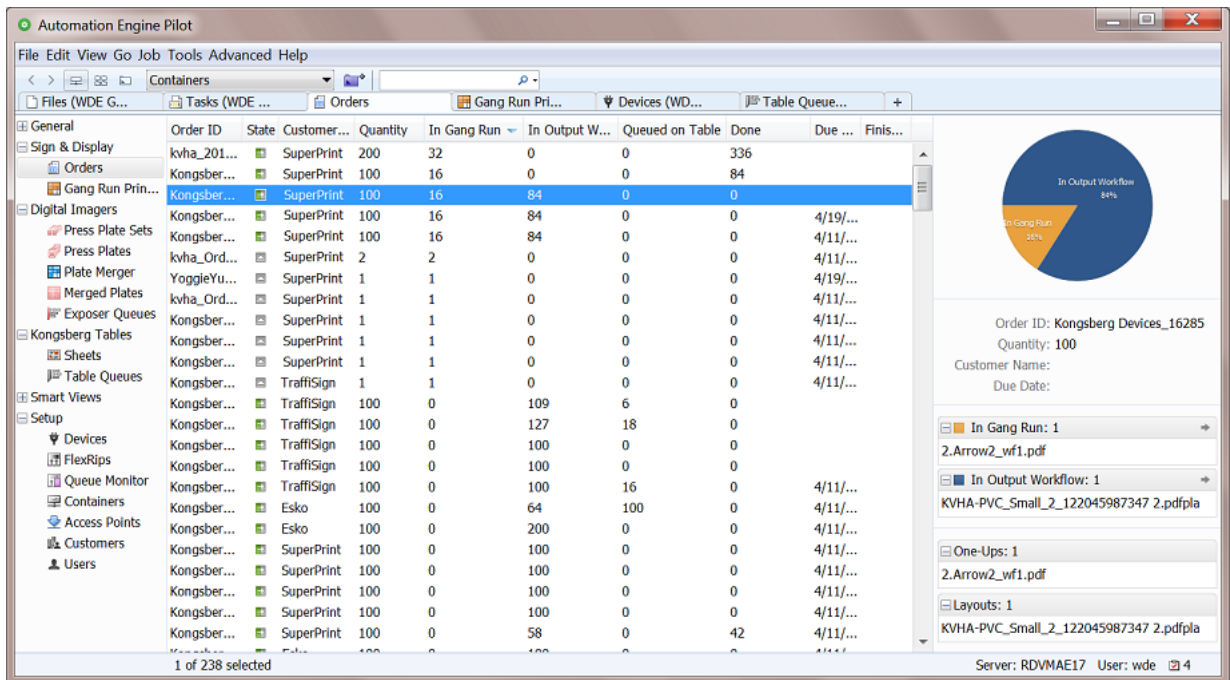

- **An Order is created** when you *submit file(s) to a Gang Run queue* and you there specified an **Order ID** (in the *tab 'Extra'*).



**Note:** An example: When you have 7 one-ups residing in a same Automation Engine Job and you first submit 5 of them and later the 2 remaining, then:

- Order ID = [Job Name]\_[Short task ID] will result in 2 different orders (the task IDs are different).
- Order ID = [Job Name] will assemble all 7 one-ups in one same order.

To get feedback from the Kongsberg table in this Orders view, the substrate queue needs to, in its *Export Gang Run Layouts* task, create a cutting file of the type "**JDF file for Kongsberg**". Only this JDF file format can provide that feedback.

- **An Order is Done** when all ordered quantities are produced by one or multiple Kongsberg cutting tables, on one or multiple sheets. When later, extra one-ups enter the gang run queue that use that same Order ID, the state changes from  (Done) back to  (Partially Done).
- **An Order is removed from this list** when it was removed by the automatic clean up tool *as configured for Device databases* or when its total number of ordered copies changed to 0 (see the note below).

### Columns



**Note:** As in many views in the Pilot, you can

- re-arrange columns by dragging their title to a new position
- sort them by clicking on a column title
- right-click a column title and choose to **Hide** this one or any other. In the list that appears, select **Select Columns...** if you want to change or re-arrange multiple items.
- use filters and optionally save them as a *Smart View*.
- define your preferred unit in **Edit > Preferences > Units**.

- **Order ID:** ID defined in the *Submit to Gang Run task* that was launched on the one-ups in this order.
- **Customer Name:** Name of the customer of which the Customer ID was defined in the *Submit to Gang Run task* that was launched on the one-ups in this order.
- **Quantity:** Total of all ordered copies, as requested in the *General tab of the Submit to Gang Run task*, for all one-ups belonging to this order. For example: The Quantity of the order is 44 when it expects 44 fruit displays in total, of which 22 apple and 22 banana variants.

When a one-up is submitted to the Gang Run with quantity "**Maximum Fill**", its (part in the) ordered **Quantity** is counted or shown as " 0 " until the nesting has taken place. Only then, the amount of this one-up that was placed on the layout is added to the total amount of one-ups for the order.





**Attention:** When one or more one-ups are deleted from a Gang Run substrate queue, or when the quantity was there changed through the **Edit** mode, the order's details in this view will automatically adapt:

- The **Remaining Quantity** of those one-ups is subtracted from the total amount of ordered copies (**Quantity**).
- When the total ordered amount of copies for an order reaches zero, the order is removed.
- The one-ups that, by removing them from the Gang Run, are no longer ordered are also removed from the list of one-ups shown in the right pane.





- **In Gang Run:** Amount of ordered copies (of which the one-ups are still) present in a Gang Run queue.
- **In Output Workflow:** Amount of ordered copies (of which the one-ups are still) in the output workflow of a Gang Run queue.
- **Queued on Table:** Amount of ordered copies present in an iPC's **My Jobs** list (still to be produced).
- **Done:** Amount of ordered copies produced on a Kongsberg table.
- **Status.** General status of the order:
  - **In Gang Run:** When all ordered copies are still in the Gang Run queue.
  - **Done:** When all ordered copies are produced by one or multiple Kongsberg tables.
  - **Partially Done:** This is the status shown in all other cases.
- **Created Date:** Date when order was created, i.e.: when the (first) one-up was submitted for this order.
- **Due Date:** Due date of the first submitted one-up for this order.

- **Finished Date:** Date when the order reached the status **Done**.

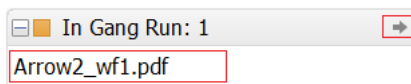
### The Right Pane: Pie Chart and Details

- A colored pie chart shows the percentage of ordered copies in one of these states:
  - **In Gang Run:** Part that is still in the substrate queue, waiting to be merged.
  - **In Output Workflow:** Part that are in the workflow where print and cutting files are being made of the nested layout.
  - **Queued on Table:** Part that has its cutting file present as a job in a Kongsberg queue (iPC).
  - **Done:** Part that has been produced on the Kongsberg table. These numbers are updated each time you close or suspend a job in iPC.
- Click  to see the amount and the names of all the **One-Ups** that were submitted and the amount and names of all the **Layouts** that substrate queues created for this order.
- **"In Gang Run"** shows the amount and the names of one-ups that are still in their substrate queue. Click  to switch to the [Gang Run Printing view](#) and see the substrate queue where the related one-ups still are. When you here click on the name of the one-up, the same view opens but that one-up is also selected.



**Tip:** Use the arrow buttons     in the Pilot tool bar to come back to this previous view.

- **"In Output Workflow"** shows the amount and the names of layouts that the gang run created but that have not yet arrived in a Kongsberg queue (iPC). Click  or on a layout name to open the Tasks view and see only the corresponding tasks.

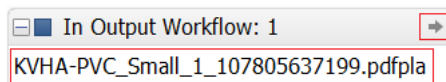

- **"Queued on Table"** shows the amount and the names of layouts that are present in a Kongsberg queue (iPC). Click  or on a layout name to open the [Table Queues view](#) and see that item selected.

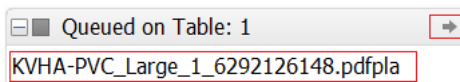

### Seeing Overruns

When the percentage of copies of one-ups in one part of the chart is larger than 100%, the part above 100% is shown in a slightly darker color. This visualises the size of the overrun.

See this example where 25 were ordered but 31 were produced ("Done" = 124%):

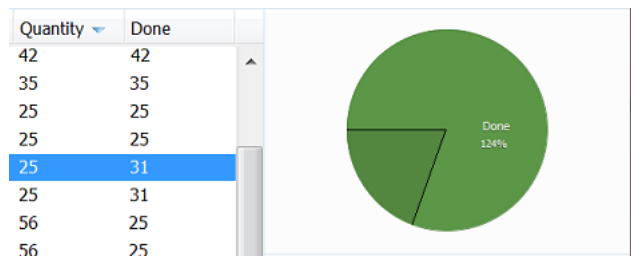

The amount of copies can become larger than 100% in these cases:

- When the gang run queue places more copies on a sheet than initially ordered (see the option [Maximum Overrun](#) in the Substrate Queue's Nesting Settings).
- When the Kongsberg table operator decides to cut more sheets than initially ordered.
- When more sheets are submitted to the Kongsberg table than initially ordered. This can happen when you overruled the number of copies in the [Submit to Kongsberg table](#) task. For orders with a large number of copies, instead of there leaving the option **Copies** to its default value **From Input File**, you could edit that field and for example submit half of the copies to table A and then launch the task again and submit the other half to table B.

## 14.10. Examples

---

These examples will help you build and understand some typical workflows.

- [This example](#) shows a basic workflow. It uses the **Shuttle** and shows how to use **Public** and **Workflow parameters**.
- [This example](#) shows how grouping keys help control the nesting. It uses a **Folder Access Point** and **SmartNames** to extract parameters from the names of the incoming files.
- [This example](#) shows how a workflow that is based on delivery of XML files. All required parameters are defined in the XMLs, including references to graphics.

### 14.10.1. Basic workflow using the Shuttle

#### Summary

In this example, a user will use the **Shuttle** to drop PDF files onto a "Submit to Gang Run" workflow. He will be asked to specify some options for that workflow. All the rest, including the output of nested layouts, will happen fully automatic.

This example specifically guides you in using workflow parameters that also become public parameters.

We assume you have been introduced to the tools we use in this example:

- The [Pilot](#). To create the workflows and the substrate queue.
- The [Workflow Editor](#).
- [Public parameters](#).

- [Workflow parameters](#).
- The *Shuttle*. This basic client application enables to drag and drop files onto Automation Engine workflows.

### Step 1 - Create the Substrate Queues

In the Pilot, create these 3 substrate queues:

- **PVC** (sheet)
- **AluComp 8 mm** (sheet)
- **Vinyl Roll 2 mm** (roll)

For each of these substrate queues,

- add minimally 1 substrate size
- in their **Nesting Settings**, set the minimum fill to 50%
- we do not have an output workflow yet, so leave that setting open. The icon of the substrate queue will show a warning sign, but we will ignore and solve this in step 5 of this example.

### Step 2 - Create the Submit Workflow

The "submit" workflow is the workflow that will be launched on the files dropped on the Shuttle. Typically it prepares your PDFs and ends with the **Submit to Gang Run** task.

The workflow that we here create is one of many possible variations. More important is the way we create the workflow parameters and public parameters.

Here is our example:

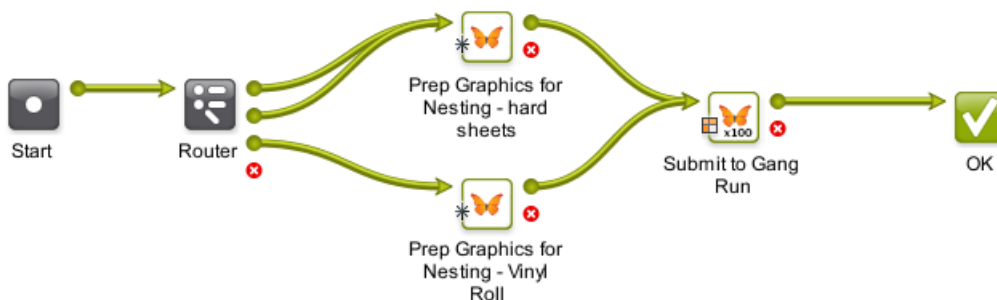

Follow these steps to create this workflow:

1. In the Pilot **Tickets** view, click to open the workflow editor and create a workflow. First simply add and connect the above steps. We will add details later, including the Router's 3 different output pins. Learn more about creating workflows [here](#).
2. Save your workflow as "GRP\_EXA1\_Submit".
3. Go to the menu **Advanced > Manage Workflow Parameters**. Click **Add** to add these 3 parameters, their value is at this point less important:

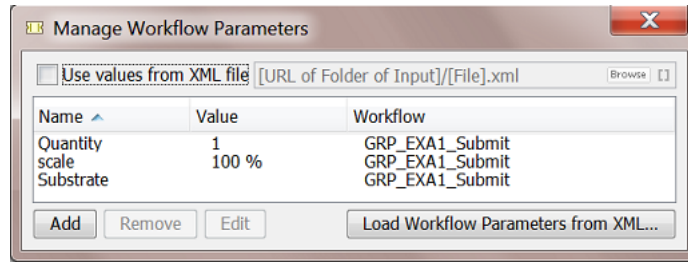

When finished, close this dialog. We can now use these new workflow parameters in the tickets.

- The **Router** uses the new (workflow) SmartName `[wfp.Substrate]` that you just created. We route based on the name of the substrate queue, a decision taken by the Shuttle user.



**Note:** You can use "is equal to" and enter their name in detail or use "contains" if this is easier.

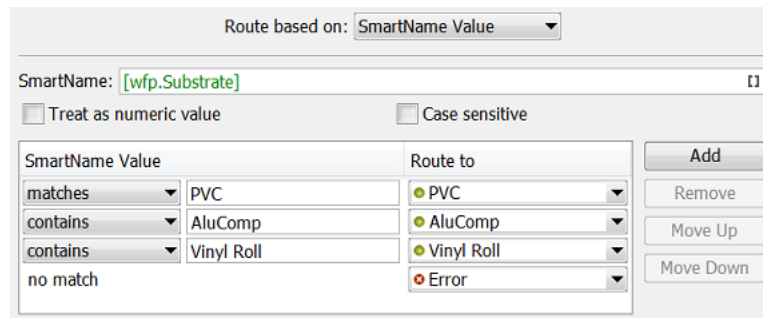

- Next we have 2 different **Prepare Graphics for Nesting** steps. This is only a suggestion ; their only difference could for example be the way they create the cut path or the SmartMarks they add. In our example, the bottom step is used for roll-output.
- Connect the **Router** output pins to their matching **Prepare Graphics for Nesting** step.
- In the **Submit to Gang Run** step, add the other 2 workflow parameters for **Quantity** and **Scale** as shown here:

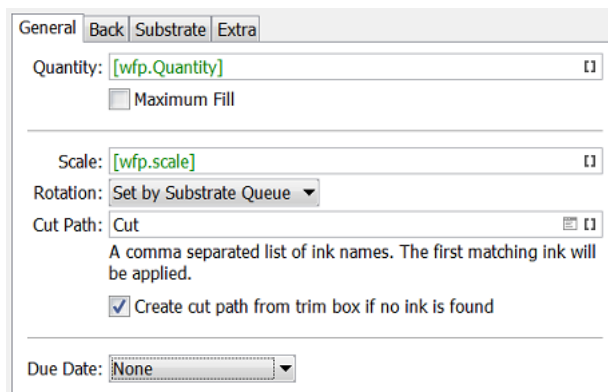

- Workflow parameters automatically become public parameters. Follow the next steps to fine-tune the dialog in which they will be shown to the Shuttle user. Still in the workflow editor, go to the menu



**Advanced > Manage Public Parameters.** The dialog will already list the workflow parameters. We only need to add some details.

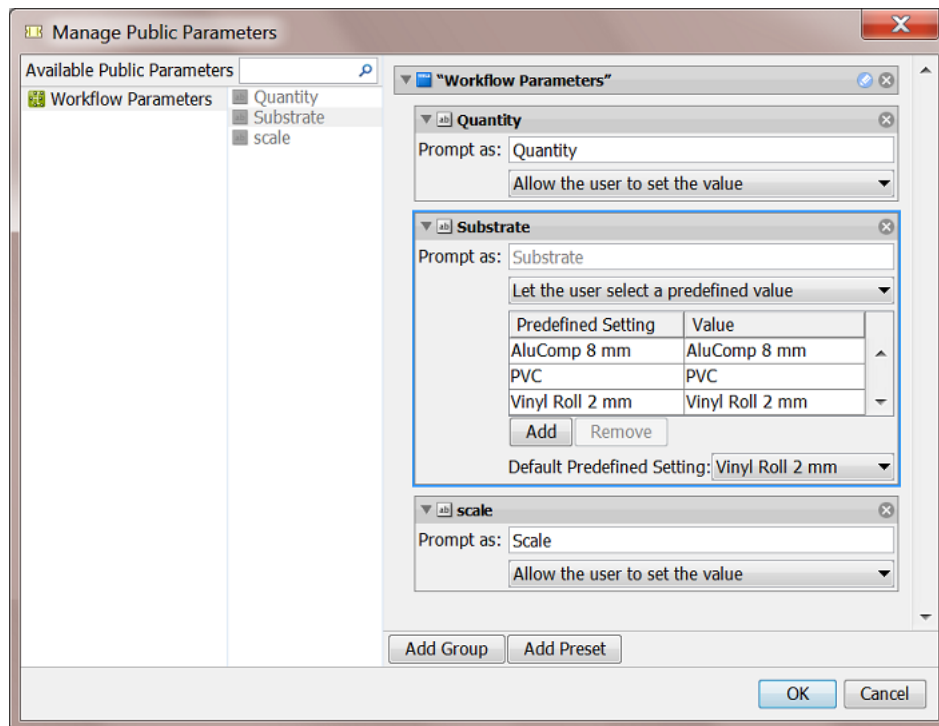

9. Add the specifics as shown in above screen shot. Click **OK** to confirm.
10. Save your workflow and close the workflow editor.

### Step 3 - Create the Output Workflow

The output workflow is the one launched by the substrate queue on the nested layouts that it created. We will use below example. Just like with the 'Submit' workflow in [Step 2](#), this is also just one of many possible variations. Again, the most important here is how we use workflow parameters.

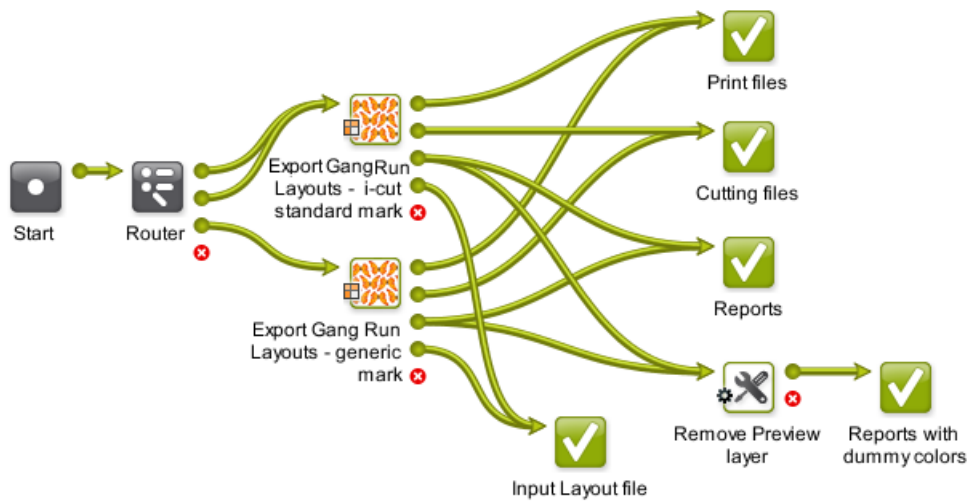

Follow these steps to create such a workflow:

1. As you did in the previous step, just simply add the workflow's steps. We will add details and more transitions later. The "Remove Preview Layer" step at the end is actually an **Optimize PDF document** ticket that was renamed. Learn more about creating workflows [here](#).
2. Save your workflow as "GRP\_EXA1\_Output".
3. Go to the menu **Advanced > Manage Workflow Parameters**. You will see 4 substrate related parameters that were added by default. This is because we used the **Export Gang Run Layouts** step in this workflow. In this example, we do not need any others. Close the dialog.

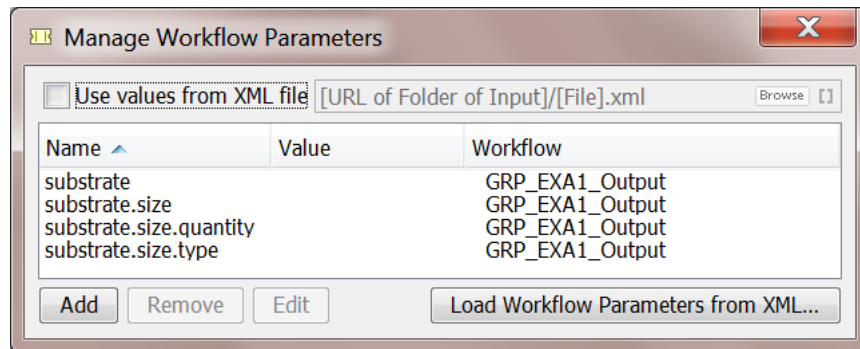

We will now use one of these workflow parameters in the tickets:

4. Much like in [Step 2](#), the **Router** should use the (workflow) SmartName `[wfp.substrate]`.

Route based on: **SmartName Value**

SmartName: **[wfp.substrate]**

Treat as numeric value       Case sensitive

SmartName Value	Route to
matches PVC	PVC
contains AluComp	AluComp
contains Vinyl	Vinyl
no match	Error

Buttons: Add, Remove, Move Up, Move Down

- The 2 **Export Gang Run Layouts** steps only differ in the set of SmartMarks that they add. The Vinyl route uses the bottom one. Here is an example of how we use the workflow parameter [wfp.substrate] in output file names and folders:

Production Files | Sheet | Reports

Save Print Files: **No Rotation**

Save Cutting Files: **as i-cut File; as PDF File**

Print Side Up  
 Sequence lines  
 Cut Across Gaps

Add Extra Structural Inks: **Crease,Kiss-cut,CUT,DieLine**  
The selected structural inks will be saved together with the cutting paths. Enter the extra ink names separated by a comma. For example: "Crease,Kiss-cut"

Output Name: **[Time]\_[wfp.substrate]**

Save all files in the same folder

Print Files: **file://eaw11dl306/WDE-AE-DATA/GRP\_output/Print Files\_[wfp.substrate]/**  [1]

Cutting Files: **file://eaw11dl306/WDE-AE-DATA/GRP\_output/Cutting Files\_[wfp.substrate]/**  [1]

Report Files: **file://eaw11dl306/WDE-AE-DATA/GRP\_output/Reports\_[wfp.substrate]/**  [1]

- The default output pins of both **Export Gang Run Layouts** steps (print, cut, report and input files) connect to an own end **OK** step that was renamed.
- The **Report** files of the **Export Gang Run Layouts** steps continue to an **Optimize PDF document** step that creates an extra report in which the preview layer was removed:

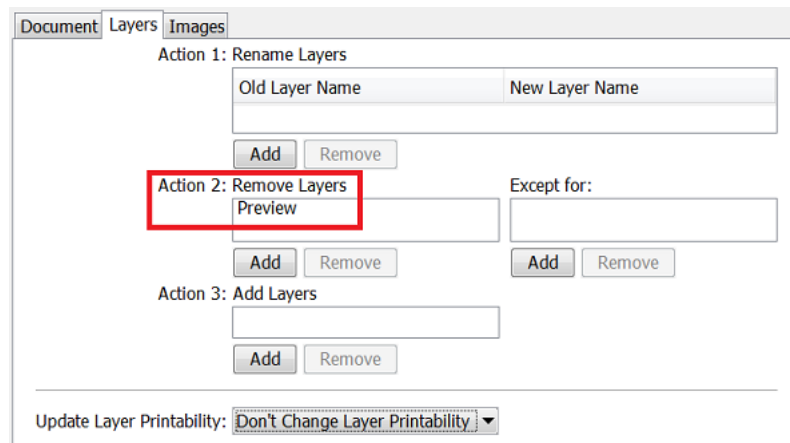

Learn more about layout reports and their layers in [here](#).

8. Save your workflow and close the workflow editor.

### Step 4 - Add the Output Workflow to the Substrate Queue

Now complete the setup of the 3 substrate queues.

For each substrate queue, follow these steps:

1. double click the substrate queue to open and edit it.
2. in **Output Workflow**, select the workflow we created in [Step 3](#) ("GRP\_EXA1\_Output").
3. click **OK**.

Here is an example of the PVC substrate queue:

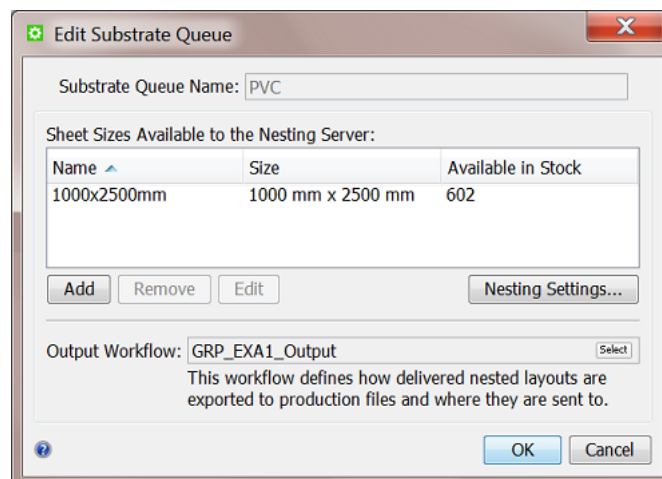

### Step 5 - Add the Submit Workflow to the Shuttle

Our Gang Run workflow is now ready for use from the Pilot.

When you set up a **Folder Access Point** and have it launch the submit workflow on the PDFs that you drop on that folder, you will not have an opportunity to specify important parameters like **Quantity** and **Substrate Queue...**

That is why we will here use the **Shuttle**. This tool enables us to have the user that drops the files answer some quick questions about the wanted parameters.

Follow these steps to set this up:

1. On your client, start the **Shuttle** and login with an Automation Engine user name and password.
2. Use the Shuttle's **View** menu to make sure you see the **Launch Panel**.
3. Click left-below on the  $\oplus$  icon to create a launch pad for a workflow. Files that you drag and drop onto this pad will be launched on an Automation Engine workflow.
4. Select the workflow from the list. We here only need the submit workflow, the one we named "GRP\_EXA1\_Submit".

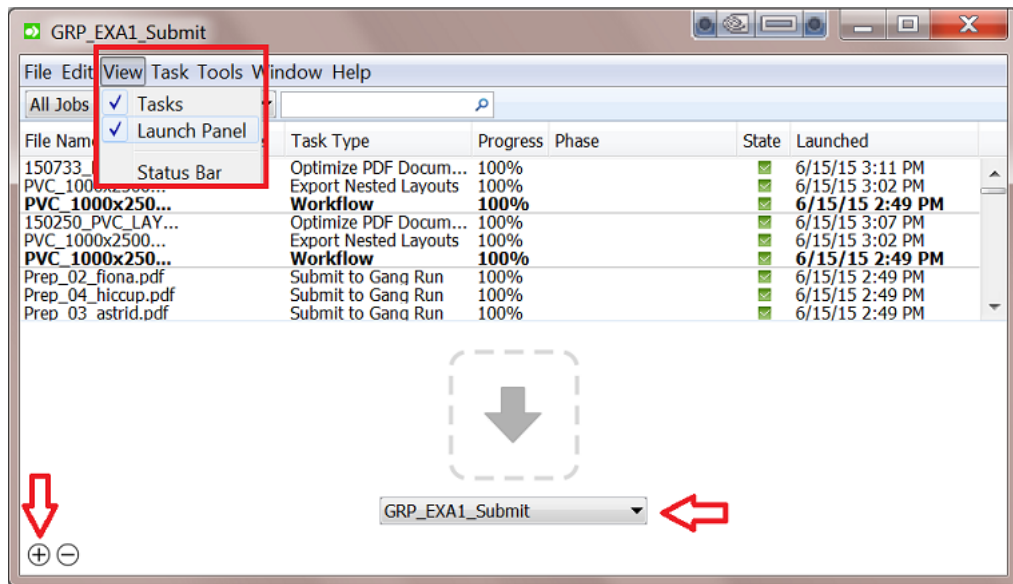

### Step 6 - Test and Monitor

We test our workflow by dropping files on the **Shuttle** and defining the public parameters. All the rest happens fully automatic. Many of below steps only serve to illustrate how you can monitor this workflow in more detail.

1. On your local PC or any place you can access in your network, select files that will share the same production parameters. In our example we select 3 PDFs of which we need 10 prints on PVC sheet material.
2. Drag and drop these files together on the launch pad of our submit workflow.
3. A **New Task** dialog will appear asking you only to define the values for the public parameters:

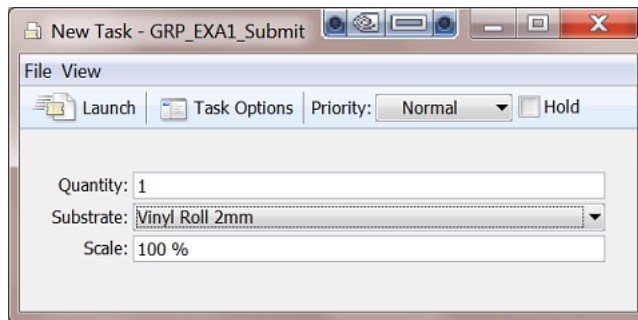

**Note:** The way they appear in this dialog (name, order, default value) is as we set up in [Step 2](#) in the **Public parameters** dialog.

4. Set the **Quantity** to 10, change the **Substrate** to PVC and click on **Launch** You will see the tasks start in the Shuttle's **Tasks** view.
5. Just for information, we have a look at the **Substrate Queue** in the Pilot, which is waiting for more graphics to reach its minimum fill.

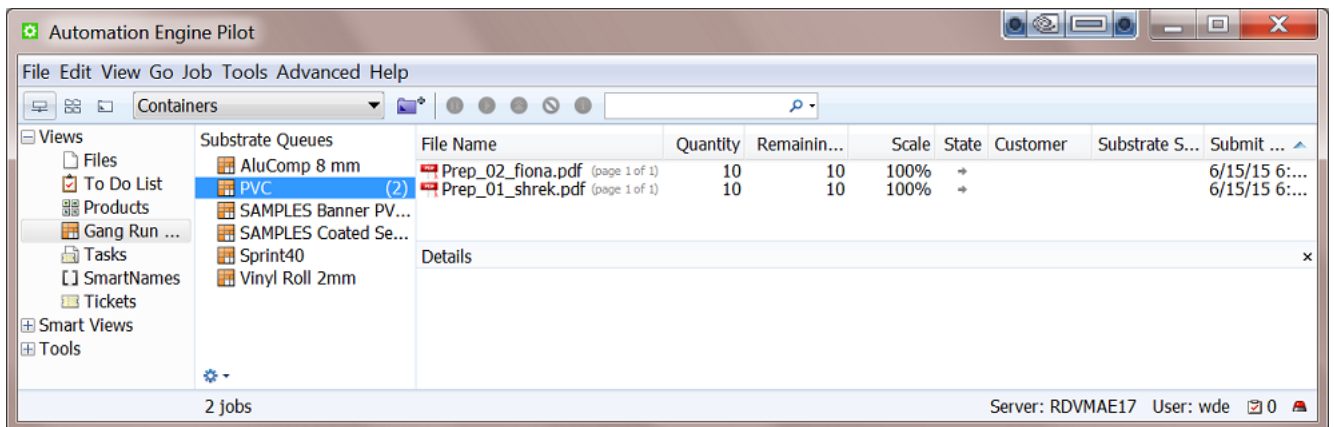

6. We go back to the Shuttle and now drag and drop the same 2 files + 2 other files on that workflow launch pad. This time we will want a different quantity and scale.
7. Because Shuttle recognizes files, it now first asks if you want to be shown the parameters again that you used the last time for that same file:

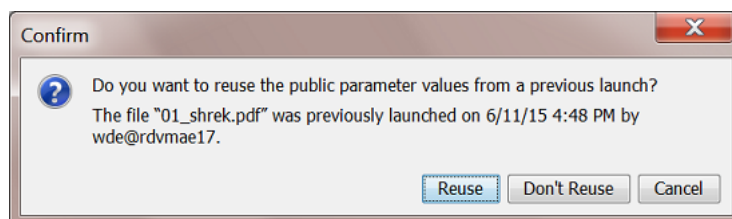

We here click on **Reuse**.

8. A **New Task** dialog opens and shows the parameters that we used previously for the mentioned file. For the 4 files that we are dropping now, set the **Quantity** to 20, keep (reuse) the **Substrate** to PVC, and change the **Scale** to 200. Then click on **Launch**.

- In the Pilot, we can monitor the PVC substrate queue. In our example, it reaches a minimum fill and so starts creating layouts on which it then launches the output workflow.



**Tip:** You can force this layout-creation by using the **Print Now** button or by lowering the **Minimum Fill** percentage in the substrate queue's **nesting settings**.

- When files are disappearing from the substrate queue, you can go to the **Tasks** view to monitor their output. Double click (one of) the launched output workflow(s) to open the workflow editor. This is how one of them looks in our example:

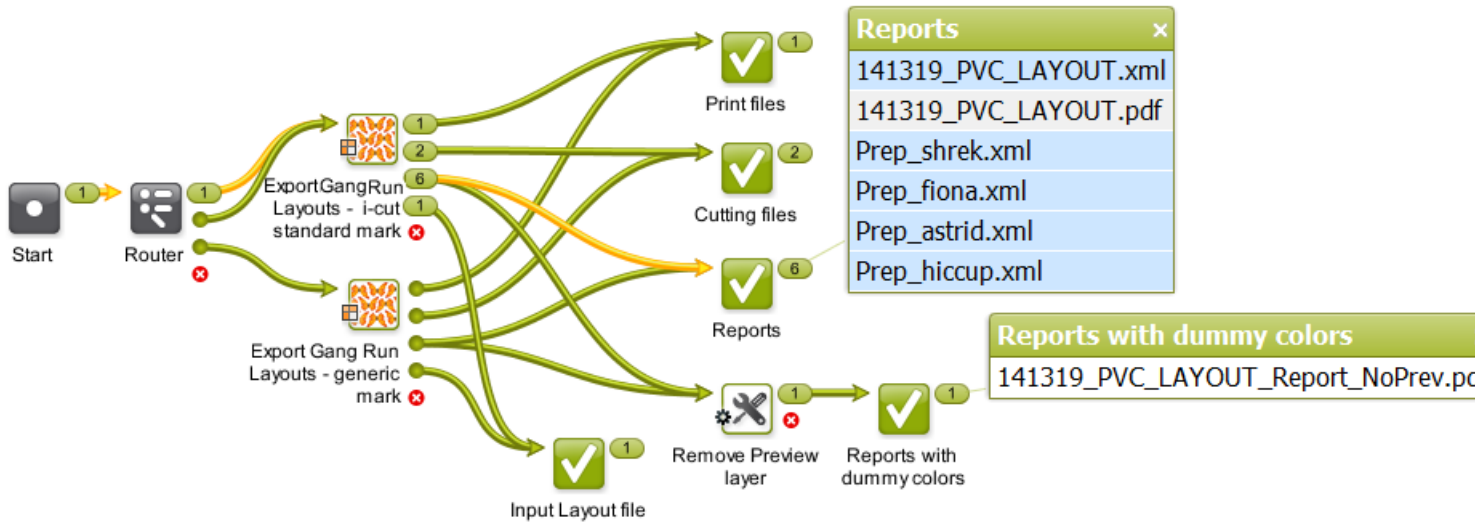

Here's a view of the report file with the preview:

141319\_PVC

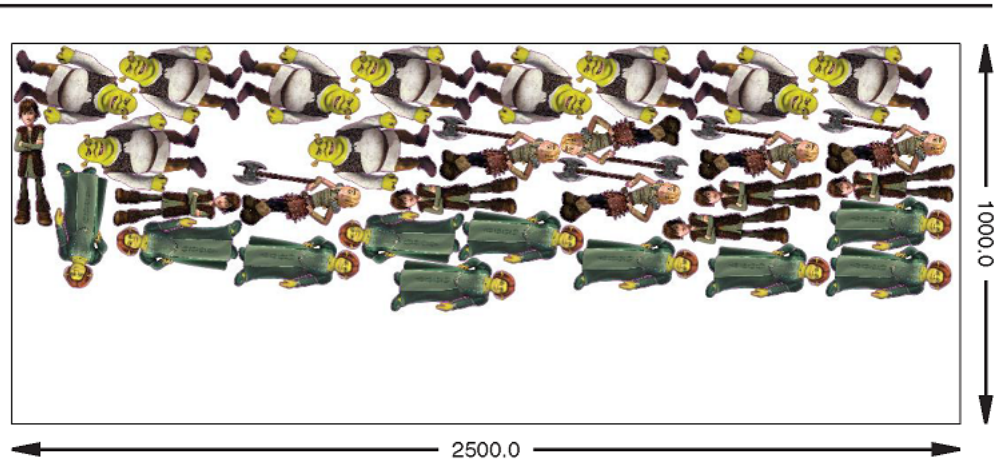

PVC - 2500x1000 # = 1 37.32% 62.68%  
 \\eaw11dl306\WDE-AE-DATA\GRP\_output\Print Files\_PVC\141319\_PVC.pdf  
 \\eaw11dl306\WDE-AE-DATA\GRP\_output\Cutting Files\_PVC\141319\_PVC.pdf  
 \\eaw11dl306\WDE-AE-DATA\GRP\_output\Cutting Files\_PVC\141319\_PVC.cut

	Prep_shrek.pdf	336.34 x 207.75	10/10
	Prep_fiona.pdf	325.24 x 140.48	10/10
	Prep_astrid.pdf	334.78 x 168.31	6/6
	Prep_hiccup.pdf	334.78 x 98.55	6/6

### 14.10.2. Working with Grouping Keys

As explained in [Working with Substrate Queues](#), **Grouping Keys** can help control which graphics end up on the same layout.

In this example we will submit a group of PDFs to be nested but we will make sure there are no layouts with graphics from different customers nor layouts that combine graphics who need lamination and others that don't.

#### Where can we get that information from a PDF (it's customer and whether it needs to be laminated)?

There are multiple ways to get such information:

- When using the Shuttle, **a user could type in** the customer name (as a public parameter). This concept was illustrated in the previous example [Basic workflow using the Shuttle](#) on page 1048.
- When the PDF resides in a Job Folder of an Automation Engine **Job**, then the customer and production parameters will be available as Job Parameter [SmartNames](#). However, many customers using the Gang Run Printing mode choose to not use this [Job concept](#).
- These parameters can also be part of an **XML** that your MIS (business system) sends to Automation Engine. This is a powerful automated workflow that is illustrated in [the example of an XML driven workflow](#).



- In this example, we will assume that those parameters are **part of the name of the PDF** input files that are dropped on a [Folder Access Point](#). SmartNames will extract those fields from the file name and workflow tickets will then use those SmartNames as values.

**Tools used in this example**

Next to the Gang Run Printing view, we also make use of

- String Extract [SmartNames](#)
- A [Folder Access Point](#)
- [Building Workflows](#).

**Step 1 - Set up the Grouping Keys**

Grouping keys can be created in the **Configure** panel. Learn details about this panel in [Gang Run Printing](#) on page 211.

For this example, follow these steps:

1. In the Pilot, go to **Tools > Configure**.
2. In the **Gang Run Printing** item of this Configure panel,

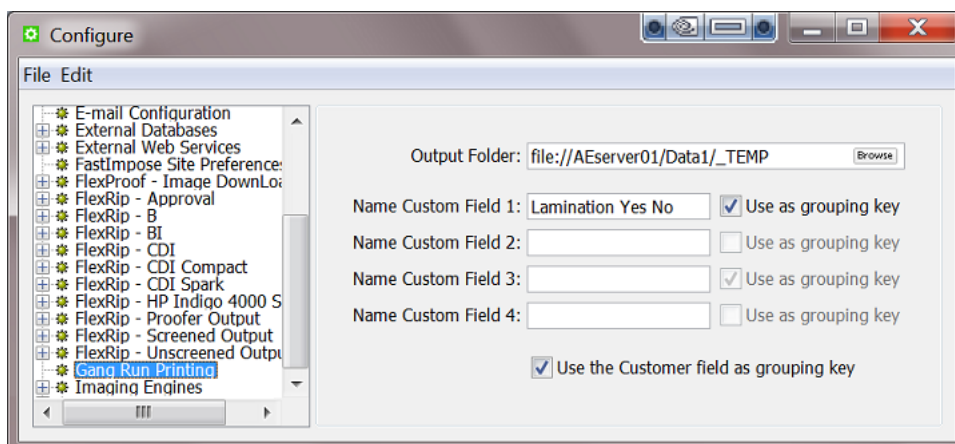





- name the **Custom Field 1** "Lamination Yes No" and select the option **Use as grouping key**
  - select the option **Use the Customer field as grouping key**.
3. Save these settings (**File > Save**) and close the panel.

We will use these grouping keys in [Step 4](#), when we pick them up in the **Submit to Gang Run** ticket.

**Step 2 - Create the SmartNames**

We will use these 4 files:

PDF file name	Preview
Stevens_Dog_LamNo_36.pdf	
Stevens_Entrance_LamYes_36.pdf	
ZooWorld_Flamingo_LamYes_90.pdf	
ZooWorld_elephant_LamYes_20.pdf	

Notice how the PDF file names are constructed as CustomerName\_DesignName\_NeedForLamination\_Quantity.pdf. We will use SmartNames to extract the needed information from the file name.



**Note:** To give you an idea when selecting your own graphics for this example, know that above samples are all approximately 200 mm by 200 mm.

### String Extract SmartNames

Follow these steps to create the required SmartNames (find more details in [Use Separation Character](#) on page 673):

1. In the Pilot's **SmartNames** view, click  to create a new SmartName.
2. Keep the default type **String Extract**.
3. Click **Insert SmartName** and in the category **File Information**, select the **File** and **Insert** it onto the canvas.
4. In **Extract part**, select **use separation character**.
5. In **Separation Character**, select the underscore character.
6. In **String Part**,
  - a. select 1, click **Save As...** and name it `Underscore_Sep_Part1`.
  - b. select 2, click **Save As...** and name it `Underscore_Sep_Part2`.
  - c. select 3, click **Save As...** and name it `Underscore_Sep_Part3`.
  - d. select 4, click **Save As...** and name it `Underscore_Sep_Part4`.
7. Now test the SmartName by, in the **Extract part of...** canvas, replacing `[File]` by typing an example of such a complete file name. Then change the **String Part** settings below to immediately see the result below in the dialog. There is no need to save at this point.
8. Click **Cancel** to close the dialog.
9. Back in the **SmartNames** view, see the resulting 4 SmartNames:

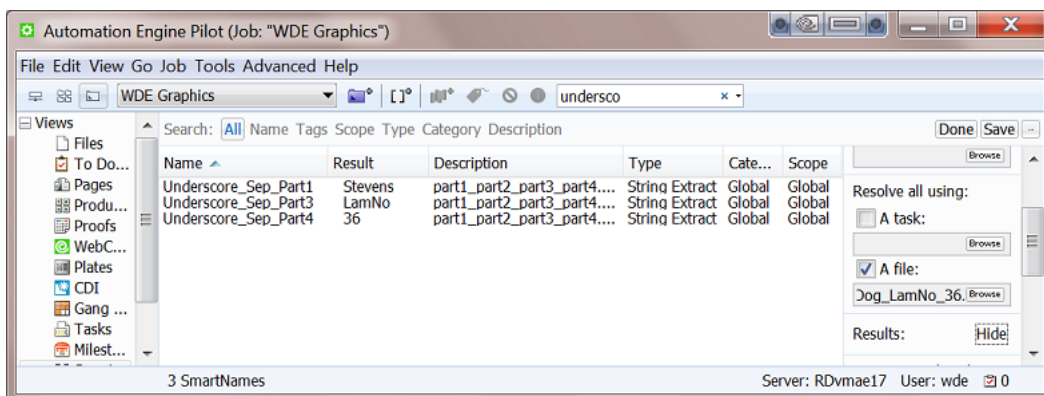

The screen shot also shows the **description** (added in the save-dialog). We also used the function **Resolve all using** and selected a valid example file. This allows to preview the **Results** in the extra column. Learn more on this in [this page in the chapter on SmartNames](#).

### Step 3 - Create the Substrate Queue

1. In the Pilot's **Gang Run Printing** view, go the menu **File > New Substrate Queue...**
2. Choose **Sheet** or **Roll** (not relevant for this example) and click **OK**.
3. Set the name to "PVC" and add a **Size** of 2500 × 1250 mm. In **Nesting Settings...**, set the **Minimum fill** to 45%. We will add the output workflow later in [Step 7](#).
4. Click **OK** to confirm and close.

### Step 4 - Create the Submit Workflow

The *"submit"* workflow is the workflow that will be launched on the files that are dropped onto the Folder Access Point. Typically it prepares your PDFs and ends with the **Submit to Gang Run** task.

The workflow that we create in this step is one of many possible variations. More important is the way we use the SmartNames.

Here is our example:



Follow these steps to create this workflow:

1. In the Pilot's **Tickets** view, click  to open the workflow editor and create a workflow. First simply add and connect the above steps. We will add details later. Learn more about creating workflows [here](#).
2. Save your workflow as "GRP\_EXA2\_Submit".

- In the **Prepare Graphics for Nesting** step, use **White Background** to base our cut path on (with our example PDFs). Choose bleed and SmartMarks as you wish. We propose to write the resulting prepared files in a specific folder and with a specific name like [File]\_Prep.



**Note:** Notice that this will add another suffix with an underscore to the input file name. This will not break the extraction logic that the SmartName uses.

- In the **Submit to Gang Run** step, use the SmartNames:

- in the tab **General**, add the SmartName that uses the extracted value for **Quantity**:

- in the tab **Substrate**, do not use a SmartName for the substrate but we pick **PVC** from the list.



**Attention:** This makes our submit workflow one that is only fit for this substrate queue. We will remember this in [Step 5](#) when we define the name of the **Folder Access Point** that will start this workflow.

- in the tab **Extra**, add the SmartName that uses the extracted value for **Customer ID** and for the custom field **Lamination Yes No** (that we created in [Step 1](#)):

- Save your workflow and close the workflow editor.

### Step 5 - Create the Folder Access Point

Creating **Folder Access Points** is documented in detail in [Creating or modifying a Folder Access Point](#) on page 1781.

Follow these steps to create what we need for this example:

- In the Pilot, go to **Tools > Access Points**.
- Click on , choose the type "**Folder**" and click **OK**.
- Choose a logic name. Remember that the workflow it will launch is specific for the substrate queue "PVC". We therefore advise to put that important fact in the name. For example: "GRP\_EXA2\_PVC".
- In **Folder settings**, choose the folder that will serve as Access Point for the incoming PDFs.
- In **Automatic Actions**, define a processing folder and choose to **Launch a Workflow** and select "GRP\_EXA2\_Submit" (the one we created in [Step 4](#)).

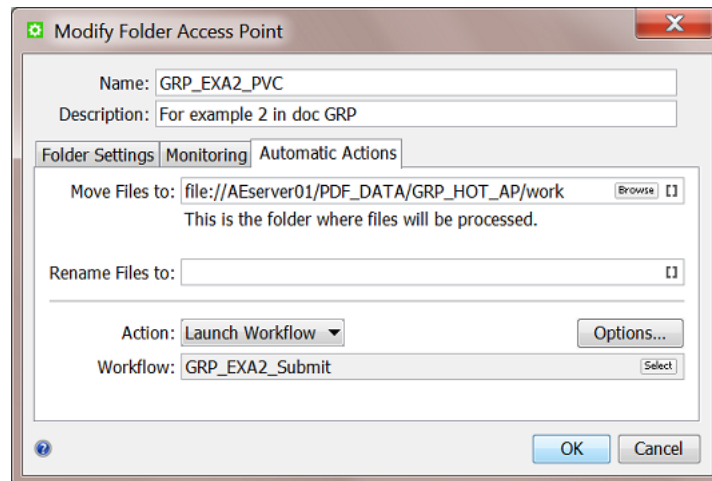

6. Click **OK** to close the dialog.
7. Check the updated list of Access Points. Notice whether it is **Active** or not.

### Step 6 - Create the Output workflow

We still need to define what needs to happen to the layouts that our Substrate Queue "PVC" will create.

We will create this basic example (a simplified version of the one we already used in [Example 1](#)):



Follow these steps to create this output workflow:

1. In the Pilot **Tickets** view, click  to open the workflow editor and create a workflow. First simply add and connect the above steps. Learn more about creating workflows [here](#).
2. Save your workflow as "GRP\_EXA2\_Output".
3. In the **Export Gang Run Layouts** step, the only thing that is specific in this example is the smart definition of the **Output Name** of (all) our **Production File(s)**:

- the SmartName [wfp.substrate] is a workflow parameter that is created automatically when you use this task type in a workflow. Click on and select it from the list of SmartNames, from its **category** "Workflow Parameters".
- the SmartName [wfp.Lamination Yes No] is also one that we want to add here but it will not yet appear in the list of SmartNames. Remember that this one started as a custom field (and grouping key) that we created in [Step 1](#).

This custom field will only appear automatically as a SmartName Workflow Parameter after the nesting server passed this information a first time to this output workflow. This means that we first have to run the whole workflow once and can then come back to this part of the workflow to pick up that new SmartName.

At this time, we will continue without adding that extra SmartName [wfp.Lamination Yes No], but we will come back to this ticket in [Step 9](#).

4. Much like in the previous example, the **Report** files continue to an **Optimize PDF document** step that creates an extra report in which the preview layer was removed ([same settings as in previous example](#)).
5. Save the workflow.

### Step 7 - Add the Output Workflow to the Substrate Queue

Although the output workflow is not final yet, we can already complete the setup of the substrate queue by adding it's name to the queue's setup.

Follow these steps:

1. Double click the substrate queue "PVC" to open and edit it.
2. In **Output Workflow**, select the workflow we created ("GRP\_EXA2\_Output").
3. Click **OK**.

### Step 8 - Test a first time

We now do a test-run of our whole example workflow, starting with the Folder Access Point.

Follow these steps:

1. Drop the 4 files described in [Step 2](#) on the folder that the **Folder Access Point** is monitoring.
2. Unless a minimum fill is not reached, all the rest should happen automatically.
  - The Pilot's **Tasks** view should show the 4 submit workflows, one for each input file.

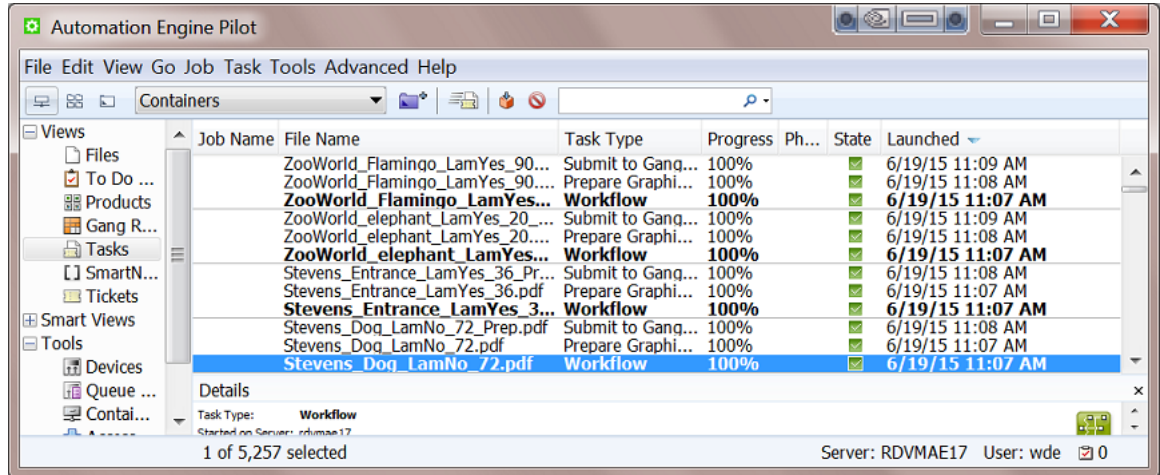

- Shortly after, the **Gang Run Printing** view should show graphics entering our **PVC** substrate queue.
- If, after a few minutes, these jobs are not output automatically, you can force the layout-creation by using the **Print Now** button or by lowering the **Minimum Fill** percentage in the substrate queue's **Nesting Settings**.
- Once output workflows have started (we only need one), we can open one of them and add the extra workflow parameter SmartName (see [next step](#)).



### Step 9 - Add the Custom Workflow Parameter to the Output Workflow

After this first execution of this workflow, we can pick up the extra workflow parameter and start using it inside the workflow tickets.

Follow these steps:

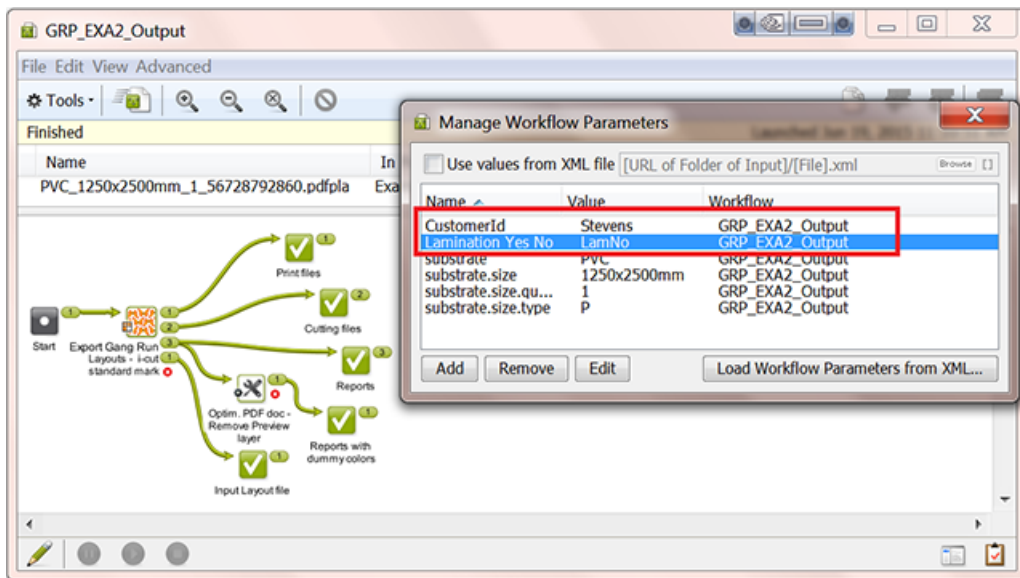
1. In the Pilot **Tasks** view, double-click (one of the ) finished output workflows to open them in the workflow editor.
2. Go to **Advanced** > **manage Workflow Parameters** and notice that we now have 2 extra workflow parameters:



3. Double click the step **Export Gang Run Layouts**. In the tab **Production Files**, in the field for **Output Name**, click on  and see the new workflow parameter SmartNames. Select [wfp.Lamination Yes No] and insert it to the Output Name field. This should be your result: Output Name: [Time]\_[wfp.substrate]\_[wfp.Lamination Yes No] .

4. Close the **Export Gang Run Layouts** step and choose **Save Ticket as...** to save it with the same name it had before: "GRP\_EXA2\_Output". Confirm to **replace** the ticket with the same name.

The workflow is now complete.

### Step 10 - Test Again and See Result of Grouping Keys

We now test the completed workflow again. We will also indicate the effect of the grouping keys that we used.

Follow these steps to test the whole workflow:

1. Remove any remaining graphics in the **PVC** substrate queue.
2. As we did in [Step 8](#), again drop the 4 input PDF files onto the **Folder Access Point**.
3. Now monitor what is happening in the Pilot's Gang Run Printing view: we see all 4 graphics and also see that the custom fields created [Step 1](#) are appearing as extra columns:

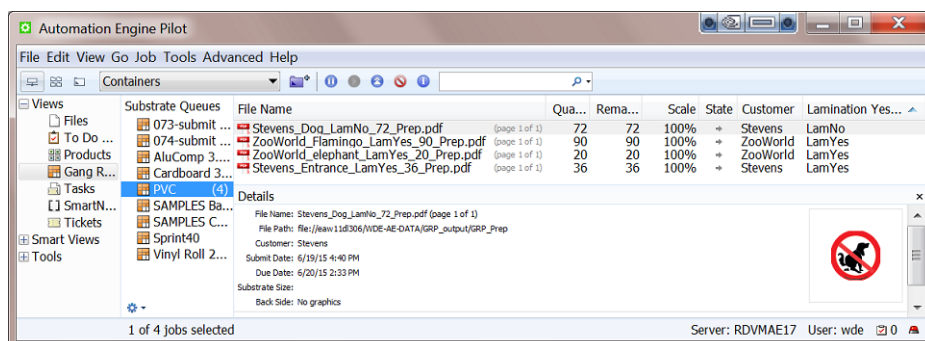



- In this example, the combination of the grouping keys and the queue's nesting settings makes that no layouts are decided (and no output workflows are launched).

To force this output, we select all 4 graphics and click the **Print Now** button . The nesting server calculates and creates layouts.

- In the Tasks view, we see the output workflows start, one for each created layout. Below we show the output PDF reports of each of these workflows. Open it by double clicking the Report PDF on the Report Files output pin:

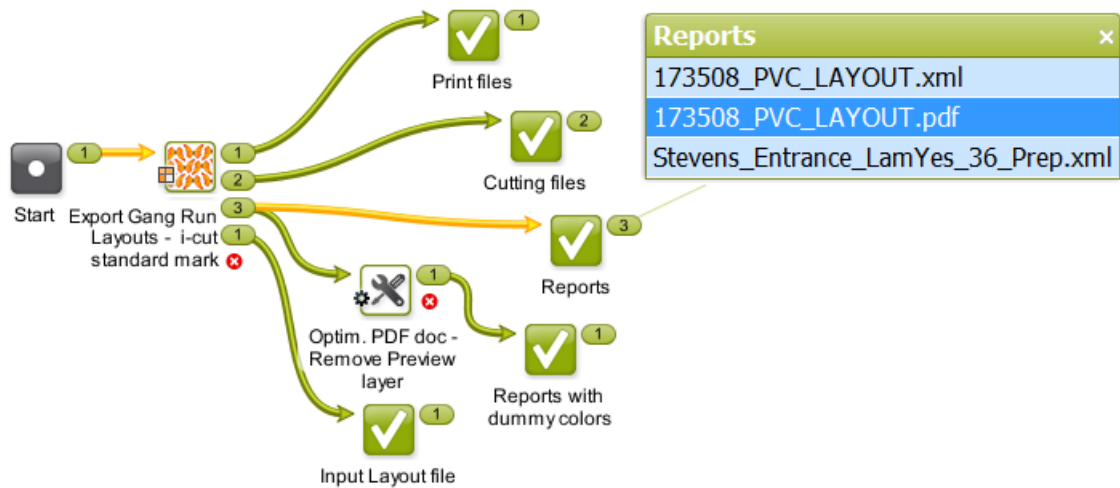

### Layout 1: the "Dog" file

This file used the grouping key values "Stevens" and "LamNo". No other file shared both of those, so the output depended solely on the queue's minimum fill percentage.

The resulting report shows us

173509\_PVC

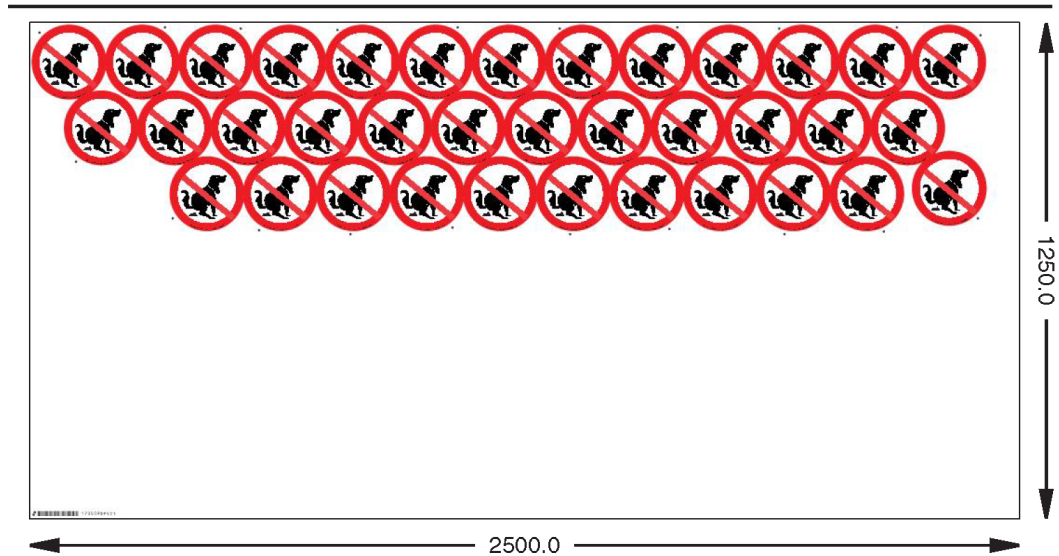

PVC - 2500x1250mm # = 1 31.1% 68.9%  
 \\eaw11dl306\WDE-AE-DATA\GRP\_output\173509\_PVC.pdf  
 \\eaw11dl306\WDE-AE-DATA\GRP\_output\173509\$PVC.pdf  
 \\eaw11dl306\WDE-AE-DATA\GRP\_output\173509\$PVCT.cut

Stevens_Dog_LamNo_36_Prep.pdf	185.34 x 185.42	36/36	Stevens	LamNo
-------------------------------	-----------------	-------	---------	-------

- only "dog" signs, no other graphics, not even the "Entrance" file that was also for customer Stevens.
- a fill rate of 31,1 %, lower than the queue's minimum fill rate of 45%.
- below right, the report mentions the custom fields as 2 extra labels.

**Layout 2: the "Entrance" file**

This file used the grouping key values "Stevens" and "LamYes". There were 2 other graphics with "LamYes", but they had a different customer grouping key. So also here, the output depended solely on the queue's minimum fill percentage.

The resulting report shows us:

173508\_PVC

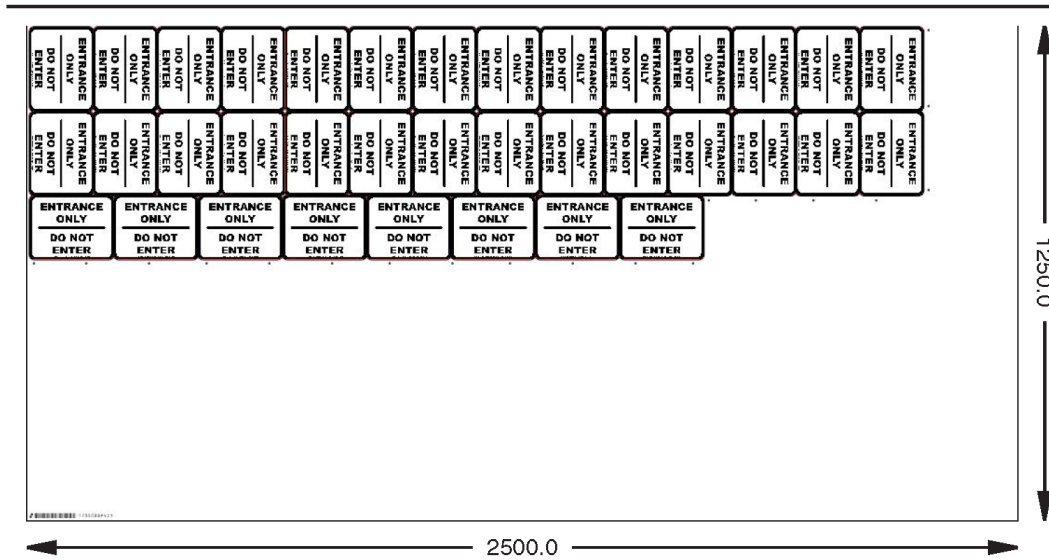

PVC - 2500x1250mm # = 1 39.42% 60.58%  
 \\eaw11dl306\WDE-AE-DATA\GRP\_output\173508\_PVC.pdf  
 \\eaw11dl306\WDE-AE-DATA\GRP\_output\173508\$PVC.pdf  
 \\eaw11dl306\WDE-AE-DATA\GRP\_output\173508\$PVCT.cut

Stevens\_Entrance\_LamYes\_36\_Prep.pdf 161.31 x 212.93 36/36 Stevens LamYes

- only "entrance" signs, no other graphics, not even the "dog" file that was also for customer Stevens.
- a fill rate of 39,42 %, lower than the queue's minimum fill rate of 45%.
- below right, the report mentions the custom fields as 2 extra labels.

**Layout 3: the "Flamingo & Elephant" files**

These graphics used the grouping key values "ZooWorld" and "LamYes". No other file shared both of those, so the output depended solely on the queue's minimum fill percentage.





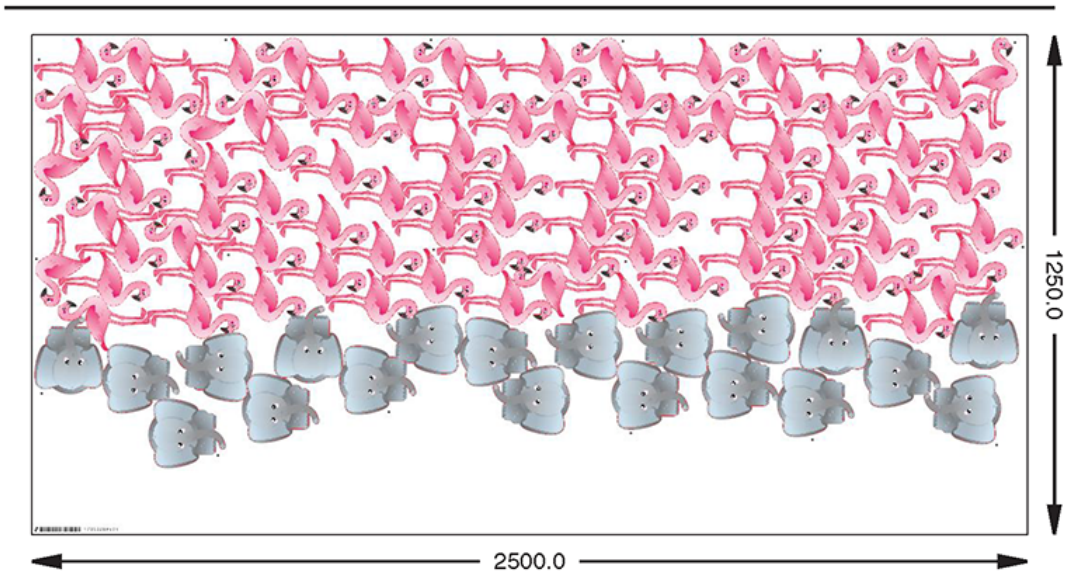

The resulting report shows us:

173532\_PVC



PVC - 2500x1250mm # = 1  38.57%  61.43%  
 \\eaw11dl306\WDE-AE-DATA\GRP\_output\173532\_PVC.pdf  
 \\eaw11dl306\WDE-AE-DATA\GRP\_output\173532\$PVC.pdf  
 \\eaw11dl306\WDE-AE-DATA\GRP\_output\173532\$PVCT.cut



 ZooWorld_elephant_LamYes_20_Prep.pdf	191.22 x 171.15	20/20	 ZooWorld  LamYes
 ZooWorld_Flamingo_LamYes_90_Prep.pdf	227.87 x 136.1	90/90	 ZooWorld  LamYes

- only the 2 graphics from customer ZooWorld, no other files. Although there was some extra space available on the sheet, we here do not see the "Entrance" job that also had the grouping key LamYes, because it did not have the same grouping key for customer ID.
- a fill rate of 38,57 %, also lower than the queue's minimum fill rate of 45%.
- below right, the report mentions the custom fields as 2 extra labels.

### 14.10.3. Basic XML driven workflow

#### Summary

In this example, we simulate a business system that writes XML files onto a Folder Access Point. These simple XML files contain both a reference to a graphic file and parameters that describe what to do with it.

As explained in [Automating your Workflow Using XML](#) on page 1043, the difference with using the [Submit XML to Gang Run](#) task is that these XML files are much simpler and also that we here stick to descriptions of 1 graphic file at the time.

In this example we assume you have read the previous examples and are thus familiar with these tools in the [Pilot](#):

- creating a [Folder Access Point](#)
- working with [Substrate Queues](#)
- working with the [Workflow Editor](#) and [Workflow parameters](#).



**Note:** In this example, the workflow parameters get their value from the input XML file.

## Step 1 - Content of XML files

### Incoming XML Files

The business system sends XML files that have a simple structure. They only list the name of the graphic file and some production parameters. They are all for the same substrate queue and size. In our example, we use 10 different XML files:

- 6 XML files represent large graphics of "American Cars" for the customer "ToyToy". Some graphics need scaling, some need different quantities. Here is one example:

```
<?xml version="1.0" encoding="UTF-8"?>
- <JOB>
  <Customer>ToyToy</Customer>
  <FileName>AmericanCars_1.pdf</FileName>
  <Quantity>10</Quantity>
  <Scale>50</Scale>
  <Substrate>AluComp 8 mm</Substrate>
  <Size>2500x1250</Size>
  <LaminationYesNo>LamNo</LaminationYesNo>
</JOB>
```

- 4 XML files represent smaller graphics for displays of movie characters for the customer "MovieWorld". Here is one example:

```
<?xml version="1.0" encoding="UTF-8"?>
- <JOB>
  <Customer>MovieWorld</Customer>
  <FileName>shrek.pdf</FileName>
  <Quantity>20</Quantity>
  <Scale>100</Scale>
  <Substrate>AluComp 8 mm</Substrate>
  <Size>2500x1250</Size>
  <LaminationYesNo>LamNo</LaminationYesNo>
</JOB>
```

They share a same value for the element "LaminationYesNo" that we will again use as a grouping key. So in our final output, we do allow these graphics to appear on a same layout. Learn more about using grouping keys in [the previous example](#).

### Graphic Files Data Structure

In this example, the business system does not know the exact place of the graphics data (full URL).

In our example, all graphics data are available as PDF in a folder named after the customer. This means that the file name and the customer name will suffice because we will use those as SmartNames to find the data.

## Step 2 - Set up the Grouping Keys

This step is identical to [the one in the previous example](#), except that in this example we will not use the **Customer field as grouping key**. So that option needs to be switched off.

We will here only use the custom field that we named "Lamination Yes No".

### Step 3 - Create the Substrate Queue

In this example, we only need one substrate queue. Learn how to create Substrate Queues [here](#).

Very similar to how we did it in the previous examples, follow these steps:

1. Create a substrate queue of the type **Sheet** and name it "**AluComp 8 mm**".
2. Add a substrate size with the name "**2500x1250**" and give it those dimensions (in mm).
3. In **Nesting Settings**, set the minimum fill to 50%.
4. We do not have an output workflow yet, so leave that setting open. The icon of the substrate queue will show a warning sign, but we will ignore this for now and solve this in [step 7](#). Click **OK** to close.

### Step 4 - Create the Submit Workflow

This submit workflow is very similar to the one we created in [step 4 of the previous example](#). We here only list the differences.

Follow these steps:

1. Create a workflow with these steps (you can already rename them as we did here):

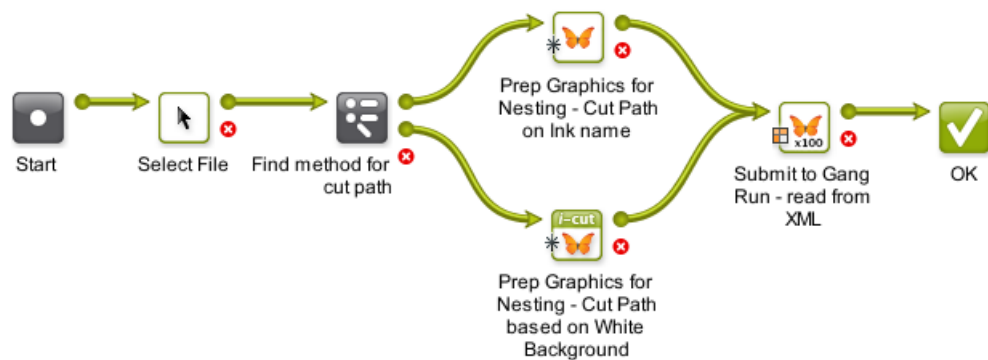

2. Save this workflow as "GRP\_EXA3\_Submit".
3. Still in the workflow editor, go to **Advanced > Manage Workflow Parameters....** In this menu,
  - a. click **Load Workflow Parameters from XML file...** and select one of the XML files that the business system sends. In the dialog that asks to select an XML element, leave the field blank and click **OK**. This creates the [wfp. . . ] SmartNames that we will use later.
  - b. select **Use values from XML file** and keep the default path [URL of Folder of Input]/[File].xml. This tells the workflow that the values for those workflow parameter SmartNames are those as specified in the input file of the workflow.

This should be the result:

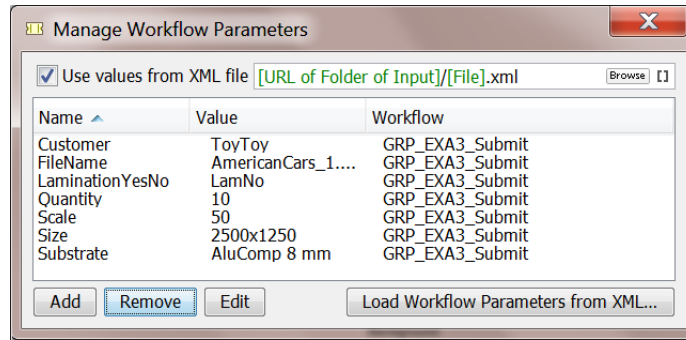

Learn more on using XML when working with workflow parameters in [Using Workflow Parameters](#) on page 859.

Close the dialog and save your workflow again.

4. In the **Select File** step,

- select **Select other Files**
- in **name matches**, enter the SmartName `[wfp.FileName]`
- in **Look in Folder**, enter a path that uses the SmartName `[wfp.Customer]`.

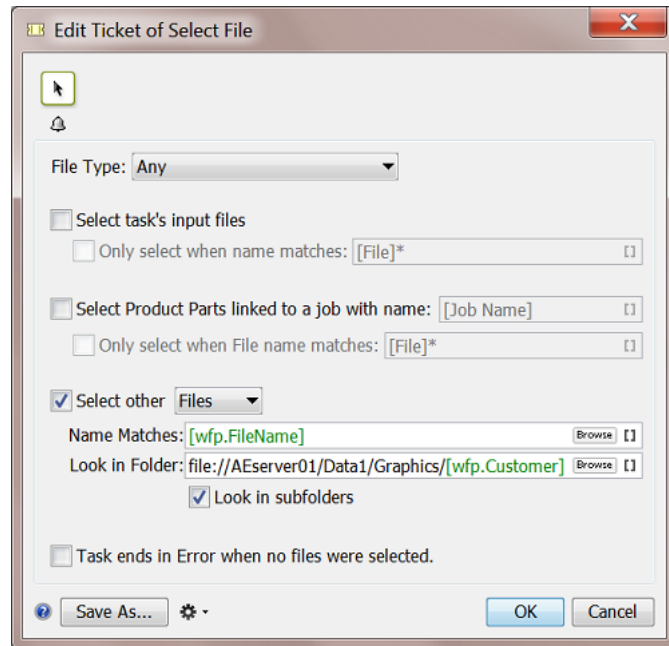

5. The **Router** serves to find if the graphic file already has a **Separation Name** that can serve as cut path.

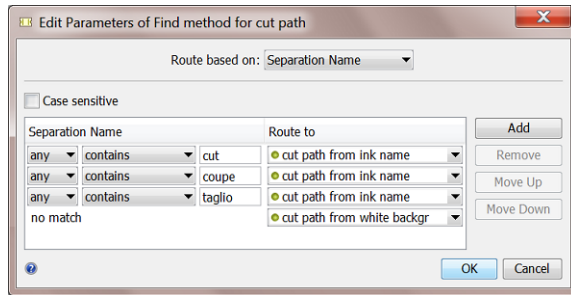

6. The two **Prepare Graphics for Nesting** steps differ in their setting **Create Cut Path from**:

- one uses an **Ink Name**:

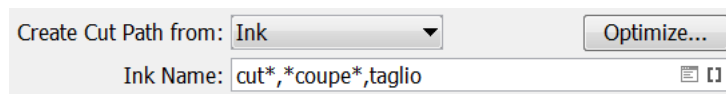

- the other one creates the path from the **White Background**.

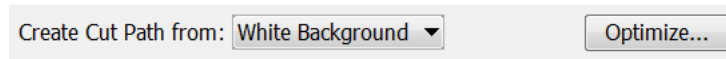

Choose bleed and SmartMarks as you wish. We propose to write the resulting prepared files in a specific folder and with a specific name like [File]\_Prep.

7. In the **Submit to Gang Run** step, use the SmartNames:

- in the tab **General**, use the SmartName [wfp.Quantity] to define the **Quantity**.
- in the tab **Substrate**, use the SmartNames [wfp.Substrate] and [wfp.Size] to define the **Substrate** and **Substrate Size**.
- in the tab **Extra**, use the SmartName [wfp.LaminationYesNo] to define the value for the custom field **Lamination Yes No**.

8. Click **OK** to close the step. Save your workflow and close the workflow editor.

### Step 5 - Create Folder Access Point

Setting up this Access Point is very similar to the one we set up [in the previous example](#).

Follow those same steps and mind these 2 differences:

- The behavior of (the workflow started by) this Access Point is decided by the values in the XML files, so its name can be generic, for example "GRP\_HOT\_SINGLE\_XML".
- In **Automatic Actions**, the workflow to launch is "GRP\_EXA3\_Submit" (the one we created in the previous step).

### Step 6 - Create the Output Workflow

The output workflow can be identical to [the one we used in the previous example](#). It was named "GRP\_EXA2\_Output".



The only SmartName we use in this output workflow is to help name the output **production files**.

### Step 7 - Add the Output Workflow to the Substrate Queue

Follow these steps:

1. Double click the substrate queue **AluComp 3.4 mm** to open and edit it.
2. In **Output Workflow**, select the workflow "GRP\_EXA2\_Output" (yes the same one as in our previous example).
3. Click **OK**.

### Step 8 - Test

All we need to do to test this workflow is dropping the XML files onto the Folder Access Point.

For every XML, one graphic file should appear in the substrate queue.

Depending on the size of the graphics and the nesting settings, some or all graphics might automatically end up on a layout and continue to the output workflow.

Here is an example result of one of the output workflows:



The **Reports** output pin shows us a link to the report PDF shown below (and also lists the other report data in XML form).

154935\_Alucomp 8 mm

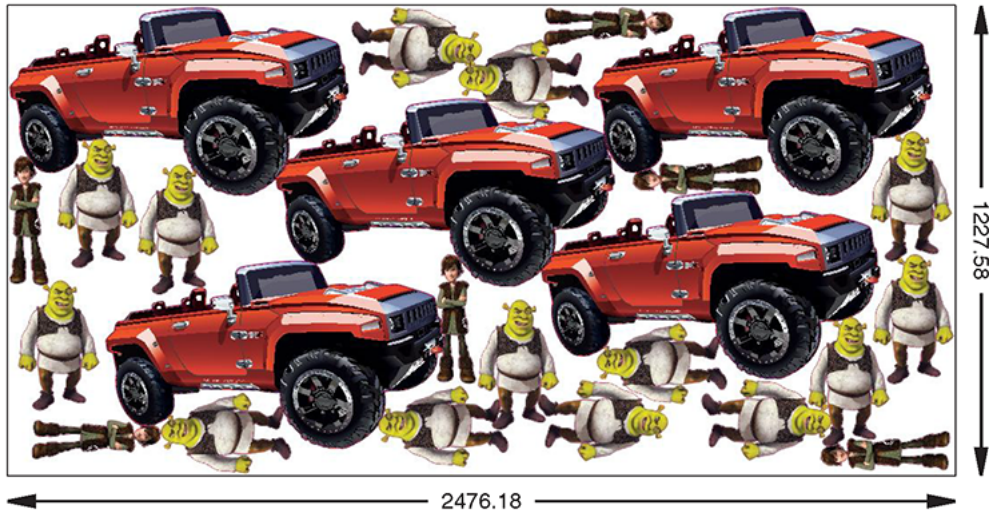

AluComp 8 mm - 2500x1250 # = 1 65.42% 34.58%  
 \\eaw11d1306\WDE-AE-DATA\GRP\_output\154935\_Alucomp 8 mm.pdf  
 \\eaw11d1306\WDE-AE-DATA\GRP\_output\154935\_Alucomp 8 mm\_CUT.pdf  
 \\eaw11d1306\WDE-AE-DATA\GRP\_output\154935\_Alucomp 8 mm.cut

	shrek_Prep.pdf	336.33 x 207.71	14/20	LamNo
	hiccup_Prep.pdf	334.78 x 98.6	6/6	LamNo
	AmericanCars_2_Prep.pdf	489.21 x 883.2	5/7	LamNo

# 15. Quality Control tools

---

## 15.1. Concept and Overview

---

Quality Control tools serve any of these reasons:

- **to prevent** unnecessary work. For example preflighting incoming designs and refusing to start prepress work on those that did not match a specific basic profile.
- **to check** the work you have done. Once you have started preparing, editing or outputting files, there are many reasons to check if what you have done is as intended. Detailed inspection and comparing helps preventing many errors.

These tools can be interactive tools or Automation Engine tasks that report a status.

Learn more in

- [Automation Engine Viewer](#) on page 1077
- [PitStop Preflight](#) on page 1146
- [GlobalVision Inspection Tasks](#) on page 1155
- [Other QC Tasks](#) on page 1175.



**Note:** This is not an overview of all Esko QC tools. This only describes the tools available through Automation Engine.

## 15.2. Automation Engine Viewer

---

### 15.2.1. Intro, Technologies and Formats

#### What is the Automation Engine Viewer?

The Automation Engine Viewer is a QC tool that enables you to view, check and compare graphic production data. And it also works with 3D, CAD and RIP'ed data.

The Viewer is started from within any Automation Engine client and can so be used by anyone on a Mac or Windows computer in your network. It is not uncommon that staff from outside the prepress department like CSRs also use this tool.

The Viewer can be started from a Pilot or a browser client. There are 2 main variants:

- a classic one based on Java technology (older).
- an HTML5 viewer, typically in sync with technologies used in the latest version of ArtPro+.

The several technological variants of this AE Viewer serve to tailor to your preferred graphics engine. Learn more about these Viewer technologies below.

### Supporting many File Formats, Comparing and more

The Viewer supports many different file types: PDF, AI, legacy file formats like ArtPro native and older Esko formats, images and even bitmap RIP'ed data. Learn more below.

You can compare files and analyse their differences, even when they have different file types and even when they have a different size. Learn more in [Comparing Files](#) on page 1117.



**Note:** The **Esko Bitmap Viewer** is similar but separate Viewer that only supports RIP'ed data. It is separate application (macOS and Windows), found on the installation DVD/set of Imaging Engine.

### Started from the Pilot or browser client

To open a file in the **Viewer**, choose any of these methods:

- click the word **View** next to the file you want to view,

Name	View	Type	Size	Date ▲
Start_Front_Speed_5L.ai	<a href="#">View</a>	PDF File	45MB	6/22/12 3:21 PM
Speed_Front_Trapped02.pdf	<a href="#">View</a>	Normalized PDF File	21MB	8/20/15 2:51 PM
Speed_Front_Trapped02_C.tif	<a href="#">View</a>	Tiff File	8.2MB	8/20/15 3:15 PM
Speed_Front_Trapped02_M.tif	<a href="#">View</a>	Tiff File	9.7MB	8/20/15 3:15 PM
Speed_Front_Trapped02_Y.tif	<a href="#">View</a>	Tiff File	3.7MB	8/20/15 3:15 PM
Speed_Front_Trapped02_K.tif	<a href="#">View</a>	Tiff File	1.5MB	8/20/15 3:15 PM
Speed_Front_Trapped02_307.tif	<a href="#">View</a>	Tiff File	249KB	8/20/15 3:15 PM

- or right-click the file and select **View...**,
- or, in the Pilot, select the file and go to **File > View**,
- or you can also browse to open another file or to select one for comparing.

Here 's an example of a file open for inspection in the Viewer (Pilot, Java based):

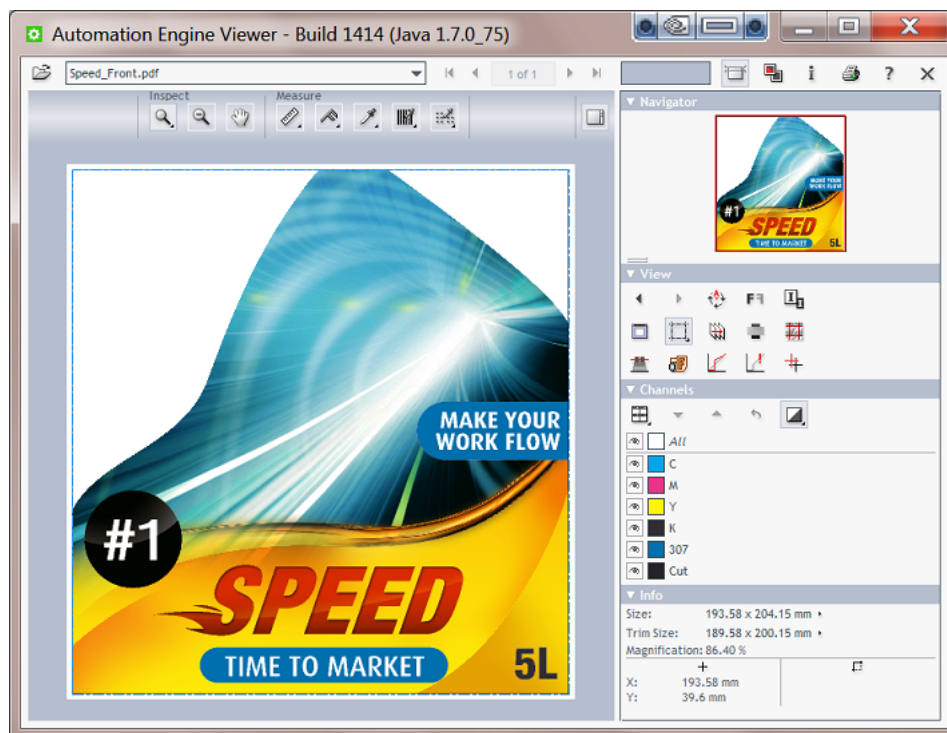

### The Concept of Prepared View Data

Foremost, a viewer tool must be reliable ; it must show data in a correct way. The Viewer does this by using the same technology as the Esko editors and RIPs.

The next main challenge for any viewer is to combine these features:

- opening files fast, even when they are big.
- being able to zoom in very deep, to show high detail, preferably also fast.

This is why you have a choice: to open files in the Viewer with or without first creating **Prepared View Data**. Learn more in [Working with Prepared View Data](#) on page 1129.



**Attention:** The latest viewing technology (starting 23.03) only offers this concept for RIP'ed data.

### Limiting who can use deep zoom

When a user does not have the **User Access Right** for *deep zoom*, then

- he can only view files that have prepared view data.
- his zoom is restricted.

This can help an administrator to avoid that a group of users that does not need a too detailed view would cause load problems on the server by accidental deep zooms.

## Several Viewing Technologies

### Same display technology as in your Editor

Most users of the Automation Engine Viewer also use an editor from Esko.

To make sure the same viewing (display) technology is used in the Viewer as in your favorite editor, you can choose which technology the AE Viewer should use, and even specify that per file format.

This configuration is done in the Pilot's [Configure panel](#).

On a new installation of AE, the default setting for the AE Viewer is to use the latest technology available: the one also used in ArtPro+. Since AE 23.03, this is also the one used in the application Esko Share & Approve (on Esko Cloud).

### Overview technologies

Automation Engine offers these viewing technologies:

- **As in ArtPro+ (latest viewer technology):** Using the ArtPro+ graphics engine (NDL), offering color management and extra functionality like 3D, CAD, text recognition, etc. (details below).
  - **As in ArtPro+ (old viewer technology):** Also using the ArtPro+ graphics engine (NDL), but without the functions like color management, 3D, CAD, text, etc. (details below).
- **As in ArtPro (old viewer technology):** This is the same technology as used in ArtPro, the classic editor that uses the graphics engine for ArtPro native files.
- **As in PackEdge (old viewer technology):** This is the same (BRIX) technology as used in PackEdge, the classic editor that uses the graphics engine BRIX. This mode enables for example to see the inks / separations of a normalized file in the same way as they are shown in PackEdge.

Learn more about Esko's various graphics engines in the chapter [PDF Formats and Metadata](#) on page 44.

### Differences between these technologies

See the below table including some notes explained below.

		As in ArtPro+ (LATEST vwr tech)	As in ArtPro+ (OLD vwr tech)	As in PackEdge (old vwr tech)	As in ArtPro (old vwr tech)
<b>Client type</b>		browser	browser	browser / Pilot	browser / Pilot
<b>File support</b>	PDF(+) files <sup>(1)</sup>	<b>yes</b> <sup>(2)</sup>	<b>yes</b> <sup>(2)</sup>	<b>yes</b>	no
	Normalized PDF files as in PackEdge	no	no	<b>yes</b>	no
	ArtPro native files as in ArtPro	no	no	no	<b>yes</b>
	Esko legacy file types <sup>(3)</sup> and (E)PS files - via hidden conversion	no	no	<b>yes</b>	no

		As in ArtPro+ (LATEST vwr tech)	As in ArtPro+ (OLD vwr tech)	As in PackEdge (old vwr tech)	As in ArtPro (old vwr tech)
	Images <sup>(4)</sup>	<b>yes</b>	<b>yes</b>	<b>yes</b>	?
	Viewing prepared data	no	no	<b>yes</b>	<b>yes</b>
	Viewing prepared RIP'ed data <sup>(5)</sup>	<b>yes</b>	no	<b>yes</b>	no
	CAD files (ARD, MFG)	<b>yes</b> + CAD layers	no	no	no
	3D (ZAE, PDF and ARD in 3D)	<b>yes</b>	no	no	no
<b>Functions</b>	Compare	<b>yes</b>	<b>yes</b>	<b>yes</b>	<b>yes</b>
	Color managed	<b>yes</b>	no	no	no
	Layers	<b>yes</b>	<b>yes</b>	Pilot only	Pilot only
	Text as text	<b>yes</b>	no	no	no
	TAC view	<b>yes</b>	<b>yes</b>	Pilot only	Pilot only
	Registration error view	<b>yes</b> <sup>(6)</sup>	<b>yes</b>	Pilot only	Pilot only
	Seamless view	no (not yet)	no (not yet)	Pilot only	Pilot only
	Invert separation	no (not yet)	<b>yes</b>	<b>yes</b>	<b>yes</b>
	PDF+ object screening	<b>yes</b>	<b>yes</b>	no	no
	PDF+ processing steps	no (not yet)	Pilot only	no	no
	GlobalVision annotations	no (not yet)	no (not yet)	<b>yes</b>	<b>yes</b>

- (1) And AI files that were saved as 'PDF compatible'.
- (2) When a PDF file is opened in the Viewer, and when the Viewer is *configured* to view PDF Files "As in ArtPro+", then this PDF file will be locked ; it can then not be renamed or deleted until it is closed in the Viewer.
- (3) Esko legacy file formats PDFPLA, STA, PLA, GRS.
- (4) Images lower than 600 ppi (higher resolutions are seen as RIP'ed data)
  - Supported: Image EPS, DCS/EPS, PSD, TIFF (< 600 ppi), JPEG, Esko CT
  - NOT supported:
    - Images with Progressive Scan compression
    - Images including linework
    - Multicolored 1-bit images

To view this type of files, first import them with the **Image Import (Classic)** task.

- (5) RIP'ed data (digital film sets) are:
  - Esko LEN/LENX
  - TIFF (> 600 ppi)
  - DCS 2.0 (> 600 ppi)
  - VIEW (Imaging Engine print simulation files)



**Note:** To be able to open **TIFF**, **LEN(X)** or **print simulation files** from Imaging Engine with the Automation Engine Viewer, you must first prepare view data using either:

- the **Make all output files ready for viewing** option in your [Imaging Engine task](#)
- the [Prepare for Viewer](#) task.

- (6) Not for RIP'ed data (digital film sets)

### Differences in how they manage Viewing Sessions

A viewing session is a single session of pixel calculation and streaming by the AE software to a Viewer client.

The above listed viewing technologies also differ in how they handle view sessions:

- When comparing 2 files,
  - the latest technology uses only 1 viewer session
  - the older technologies use 2 sessions.
- When a view session is idle (not used) for a while,
  - the latest technology closes the non-used session automatically
  - the older technologies close the non-used session when a new one is opened.
- When viewing RIP'ed data,
  - the latest technology consumes a view session
  - the older technologies do not consume a view session.

You can configure a limit to the amount of view sessions in the page [Processing Capabilities](#).

### About Working with Prepared View Data

The data shown in the Viewer are always pixels, referred to as 'view data'. Usually, you need to zoom in quite deep to see these pixels appear. This is also because these pixels are (re-)created on the fly: when you zoom in further, you are automatically shown a new set of view data that again guarantees an optimal view.

When such view data is prepared beforehand, the Viewer can open the file instantly.

When the view data was not prepared, it will be created automatically when you open the file in the Viewer. The time this takes depends on the available power on the server and on the size of the file (horizontal x vertical x the amount of separations).

### Always needed for RIP data

The Automation Engine Viewer will only open RIP'ed data that were prepared to be viewed.

This is done by the [Prepare for Viewer task](#) or as an option inside Imaging Engine tasks ('Make all output files ready for viewing').





**Important:** View data that were created with another viewing technology than the *current one selected for RIP'ed data* will need to be created again.

### Possible for Graphic files when using Older Viewing Technologies

Learn about viewing technologies in [Several Viewing Technologies](#) on page 1080.

- Older viewing technologies also worked with prepared view data of graphic files.
- The latest viewing technology no longer offers this concept for graphic files, it still does for RIP'ed data. The [Prepare for Viewer task](#) will fail when it is asked to prepare graphic files in a configuration where it is set to use the latest viewing technology.

Learn more about this topic in [Working with Prepared View Data](#) on page 1129.

## Opening the Viewer

### Opening from a Pilot or browser client

In a Pilot, depending on the file format and the defined [viewing technology](#), the file will open in the Pilot as a new window or it will open the Viewer in a browser, as a new tab.

You can use as many Viewers as your Automation Engine server has (licenses for) client connections. Opening the Viewer does not allocate an extra client connection.



**Note:** When working with the Pilot, you can open multiple Viewers on the same workstation by opening a second Pilot (**File > New window**) and opening a file in the Viewer from there. Mind that this is not required when comparing files. Learn more in [Comparing Files](#) on page 1117.



**Note:** When you open a PDF "as in ArtPro+" (old viewer technology) and there are missing external references, missing fonts or outdated placed art/images, the viewer will show an error message.

### "View" Statuses in the Pilot

In a Files view, the **View** column can display any of these statuses:

- (-). A dash indicates that the file is not viewable. For example TXT, XML, PAF, TCP, non-PDF office documents, etc.
- **View**. The word 'View' in black indicates that the file is viewable when its file type as indicated by the file type extension corresponds with its real file type.
- [View \(Prepared\)](#). The word 'View' as a hyperlink in blue indicates that the file can be viewed and the extra '(Prepared)' means that prepared view data are available. The file will open quickly. Learn more in [Working with Prepared View Data](#) on page 1129.
- [View](#). When only the blue hyperlink is shown, the file can be viewed but no view data were prepared. View data will be created on the fly while opening the file in the Viewer.
- - ~~(Prepared)~~. This indicates that the file can not be viewed because it has prepared data that are outdated. Solve this by deleting the view data or by preparing new view data. Learn how in [Working with Prepared View Data](#) on page 1129.

### Viewing RIP'ed data (Digital Film Set)

To view RIP'ed files in the Viewer, the situation is slightly different:

- For **LEN** files, you always need prepared view data. The 'view' statuses in a Pilot then mean this:

- [View \(Prepared\)](#). This indicates that the file has up-to-date view data and can be viewed.
- - [\(Need View Data\)](#). This indicates that the file has no view data. It can therefore not be viewed in the Viewer.
- - [\(Prepared\)](#) indicates that the .LEN files have view data, but that the view data is not in sync with the original file and can therefore not be viewed.
- For **TIFF** files, the behavior depends on the resolution of the file:
  - A TIFF file with a resolution lower than 600 ppi can be viewed without having prepared view data.
  - A TIFF file with a resolution higher than 600 ppi must have up-to-date prepared view data to be able to view it.



**Note:** The resolution is only checked after you clicked on [View](#) (icon). A warning will be shown when no required view data are found.

Learn more in [Working with RIP data](#) on page 1133.

### Checking and Controlling the load of Viewing sessions on your server

The amount of active viewing sessions can put a significant load on your Automation Engine server. The file's size, separations, type, amount, whether users are comparing, non-prepared zoom-requests and the server's CPU all are factors in this load.

The [View Sessions](#) on page 2057 page in the browser client's Admin section shows the **currently active** view sessions.

The [Load History](#) page in the browser client's Admin section shows the **historical load** of your server's viewing sessions.

To avoid overloads, an administrator can control this in the page [processing capabilities](#) in the [Server Admin](#) web pages.

## 15.2.2. User Interface (Pilot - Java version)

The Viewer window that opens from a Pilot is technically also known as the Java (based) Viewer (referring to the base software code that it is built in). The Viewer inside a browser is in that regard built in HTML5 code.

The UI of the Java based Viewer is similar but different than the UI of the Viewer opened in a browser.

Since v23.03, the AE manual only describes the UI and use of the latest viewer technology (in a browser).

The older java based version of this Viewer in AE is still documented in the AE user manuals of v22.11 and older. Select a version in the list on [AE's documentation page](#) and see its chapter 'Quality Control Tools'.

## 15.2.3. User Interface (Browser client - Latest technology)

## AE Viewer Window Layout

The *latest viewing technology* always opens the Viewer in a browser client. The color mode (dark or regular) is decided by the setting in your browser.

These are the main parts of its layout:























1. The browser client's top bar from the selected workspace. It appears in above example because this is a window where a file was opened from within the browser client's "My Workspace":

This bar will not be there when a file was opened from outside a browser client (the URL will then show that it is a dedicated viewer page `servername:9000/viewer/...`).

2. The Viewer's Information bar. Left to right:

- **Document name.** Click to open a **Select File** pane and select another document.
- **Show Annotations:** General slider to show the file's annotations or not.
- **User name:** the user who opened this file in the Viewer.
- **Reset Layout.** Click here to reset the layout to its default settings (for example to put tools back in their default place).
- **Print.** In case you want to share information that is visible in the Viewer to people who do not have access to the Viewer, you can use this tool. Learn more in [Print](#) on page 1099.

-  **Close** the Viewer (when opened from a browser client). When opened from a Pilot, closing this Viewer is done by closing the browser tab.
3. The Viewer's top tools bar (items depend on the opened file type - graphics, CAD, RIP'ed). Left to right:
- : Click to enable or disable the 2D and or 3D view. Learn more in [Working with 3D](#) on page 1135.
  - **Navigation** (Learn more in [Zoom, Pan, Navigate](#) on page 1088).
    -  **Zoom**
    -  **Zoom in**
    -  **Zoom out**
    -  **Fit document in view**
    -  **Zoom to 1:1 Pixel**
    -  **Pan**
  - **Orientation** (Learn more in [Rotate and Mirror](#) on page 1090).
    -  **Rotate**
    -  **Mirror**
  - **Measure** (Learn more in
    -  **Ruler**: Learn more in [Measure Distances and Angles](#) on page 1090.
    -  **Measure Color Percentages**: Learn more in [Measure Color](#) on page 1092.
    -  **Calculate screen ruling and angle**: Only functional for RIP'ed data: Learn more in [Calculate Screen Ruling and Angle](#) on page 1093.
    -  **Check Barcodes (powered by GlobalVision)**: Learn more in [Check Barcodes](#) on page 1093.
    -  **Check Braille (powered by GlobalVision)**: Learn more in [Check Braille](#) on page 1095.
    -  **Caliper**: Learn more in [Measure Heights and Widths with a Caliper](#) on page 1096.

- **Text:** Learn more in [Measure Text](#) on page 1097.
-  **Select Text:** Find occurrences of specific text.
-  **Detect Font:** Read which Font a text uses.
-  **Check Font Sizes:** Find text with a font size smaller than.
-  **Compare:** Learn more in [Comparing Files](#) on page 1117.
-  **Info:** Opens the file's standard 'Info' dialog as used in AE browser client.











Learn about keyboard shortcuts [here](#).

#### 4. The Viewer's **Right** tool bar (depending on file type graphics, CAD, RIP'ed)

Click a tool's icon to open it separately in a widget or click the arrow  below to open all tools in a right side pane.

You can drag the tool's icons up or down to re-arrange them in this bar.

You can also click and drag a tool's icon to the left side bar.

-  **Navigator:** Learn more in [Navigator tool](#) on page 1100.
  -  **View:** Learn more in [View tool](#) on page 1100.
  -  **Channels:** Not visible when viewing CAD files. Learn more in [Channels tool](#) on page 1105.
  -  **Info:** Learn more in [Info tool](#) on page 1108.
  -  **Layers:** Not visible when viewing CAD file types. Learn more in [Layers tool](#) on page 1109.
  -  **CAD:** Only visible when viewing CAD file types (ARD, MFG). Learn more in [CAD tool](#) on page 1108.
  -  **Color Management:** Learn more in [Color Management tool](#) on page 1109.
  -  **Quality Control:** Learn more in [Quality Control tools](#) on page 1110.
- #### 5. The Viewer's **Left** tool bar. By default, these tools appear in the left tool bar:
-  **Document Select:** Learn more in [Document Select widget and tools](#) on page 1121.
  -  **Annotation List:** The Viewer can show you the annotations that users made in Share & Approve. Learn more in [Working with Annotations](#) on page 1139.

When you moved all tools out of this tool bar, it will disappear.

There are more tools that are described in other dedicated pages:

- [Working with RIP data](#) on page 1133.
- [Working with Multi-Page Files](#) on page 1143.



## 15.2.4. How To (Top Tools Bar)

This describes the tools in the top tools bar and some other generic tools that you can use on all types of files.

### Zoom, Pan, Navigate

On macOS, as a standard practice, replace below mentioned **Right-click** by **Ctrl-click** and replace **Ctrl-** by **cmd-**.

#### Zooming

Click the  icon or press 'Z' to activate the zoom tool. The mouse changes to .

These shortcuts are now enabled:

<b>Click</b>	Zoom in by a factor 2
<b>Double-click</b>	Zoom in by a factor 4
<b>Right-click</b>	Zoom out by a factor 2
<b>Alt + click</b>	Reverses the zoom to zoom out 
<b>Mouse scroll</b>	Zoom in/out with the location of the mouse as center
<b>Click + drag a rectangle</b>	Zoom in to that area. Hold the <b>Space</b> bar to move the area.

Double-clicking the  icon serves as : 'Fit Document in View'.

#### Fit Document in View

Right-click the  icon to specify if you want to **Fit Document Width** or **Fit Document Height**.

#### Zoom to 1:1 Pixel

When you have artwork with a defined resolution, you can use it to zoom to the image resolution.

Right-click the  icon to see your options:

- **Zoom to 1:1 Pixel:** Shows the image in its rasterized resolution.
- **Zoom to Actual Size:** Shows the document in the size corresponding to its printed size. You may need to set your monitor resolution to make this accurate.
- **Set Monitor Resolution:** Your set monitor resolution will be stored in the Viewer.

You can specify the resolution as a decimal number (e.g. 36.05 ppcm) or as a fraction in the `pixels / size` format. Learn more in [this Knowledge Base article](#).



**Note:** When the monitor resolution is not set or when the image resolution is not set, the Viewer takes 72 ppi as default.

## Panning

To pan, click the  icon to activate the pan tool, then drag the image by holding down the left mouse button and moving the mouse.

- **Pan while Zooming:** While zooming, you can temporarily switch to the pan tool by holding down the **space** bar.
- **Zoom while Panning:** While panning, you can still use these zoom shortcuts (which will use the mouse point as the center): double-click (in), right-click (out), scroll (in/out).
- **Systematic Panning:**
  - **Ctrl + 'arrow'** pans the image 25% of the window size in the direction of the used arrow.

## Other / Legacy Keyboard Shortcuts

- **Photoshop style keyboard shortcuts:**
  - **Ctrl-+''** zooms in with a factor 2.
  - **Ctrl-''** zooms out with a factor 2.
  - **Ctrl-'0'** fits the file in the window.
- **PackEdge style keyboard shortcuts:**
  - **F5** zooms in with a factor 2.
  - **F6** zooms out with a factor 2.
  - **F7** temporarily switches to the pan tool to allow one drag pan.
  - **F8** temporarily switches to the zoom tool to allow one drag zoom.
  - **F9** fits the file to fit in the window.

Learn more shortcuts on [this page](#).

## Navigator

In the right side bar, click  to open the **Navigator** widget. It gives an overview of the current view position. Use this widget to quickly navigate through the entire document.

The navigator highlights the zoomed in area with a dotted rectangle. When there is no zoom, the dotted rectangle will be around the entire document.

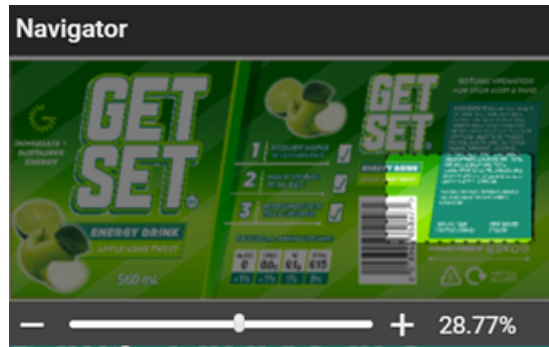



You can navigate through your document by

- holding the mouse and drag this selected rectangle to a new place. The Viewer's main view window will change accordingly.
- clicking outside the rectangle to move the rectangle to the clicked point. The Viewer's main view window will change accordingly.

The bottom of the widget mentions the current zoom percentage and a slider bar. You can use the slider or click the + or - to adjust the zoom level.

### Rotate and Mirror

-  **Rotate:** Rotates the current view 90 degrees clockwise.
-  **Mirror:** Mirrors the current view (shortcut **Ctrl - M**).

Use this to flip the document vertically from the center of the current view. If you are zoomed in, the center of this area will be used as the reference.

### Measure Distances and Angles

The **Ruler** tool calculates the distance between any two points in the work area with a click-drag-release action.

When you measure from one point to another, a line is drawn and measurement information is shown near the second position.

The used units are those set in the Info panel. Use the shortcut **Ctrl - U** to switch between units.



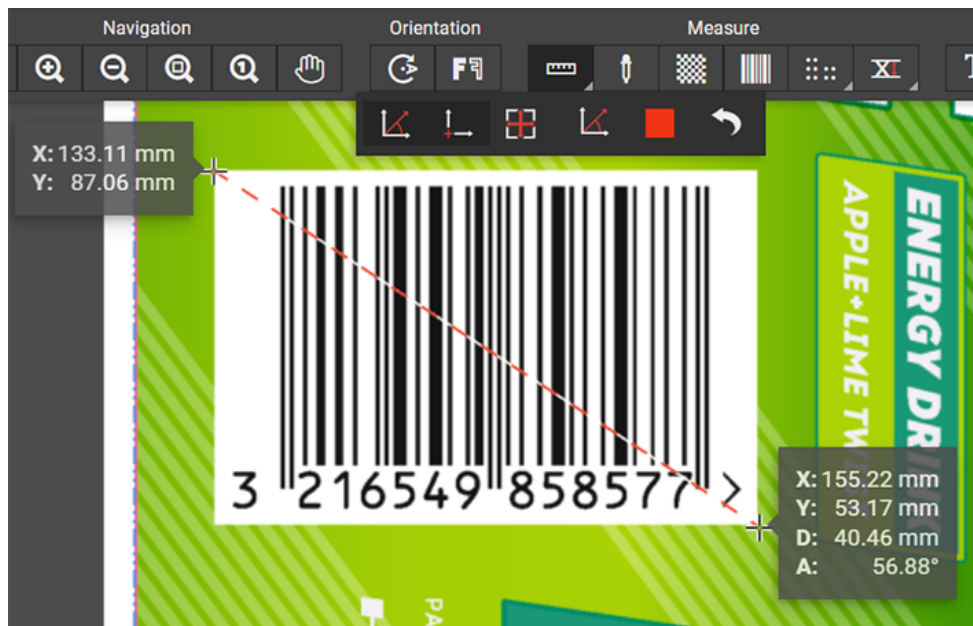



### Settings

In the top tools bar, click  to see and select one of the 6 options:





The first 3 define which measurements the pop-up info will show (see the example above):

- : Displays the Angle (A) and the Distance (D)
- : Displays the starting and end location (X, Y # X, Y)
- : Displays the horizontal (W - width) and vertical (H - height) distance traveled from the X- and Y axes.



**Note:** You can choose to display all of the measurements by selecting all 3.

The next 3 are configuration choices:

- : Displays the Angle (A) positive upwards (Counter-Clockwise) or  downwards (Clockwise).
- : Changes the color of the ruler line (dashed).
- : Resets the color of the ruler line to its default.

### Various ways to use the Ruler

- Click a beginning and end point.
- Click a begin point and drag away from that point. The measurement information is shown and updated interactively.
- You can also move the start or end point by slowly approaching it, seeing the mouse pointer change and dragging it to a new position.



**Note:** While viewing CAD data, the **Ruler** will snap to the end points of most line segments in the CAD drawing.



**Tip:** The Ruler tool can be combined with Navigation tools. You can for example click a first point, then change the view by zooming out or navigating, and only then indicate the second measuring point. This allows much more precision.

### Measure Color

There are various ways to measure color:

- Select the  densitometer tool and either click a point in your file or click and drag a rectangle.
- Double-click the densitometer to make a measurement based on the current selection or, when no selection is active, based on the current view.

The measured dot percentage in that point or area is shown both in a pop-up in the view area and also in the **Channels** widget. The location is shown in the **Info** widget.

By default, the measured densities are also shown in a pop-up near the location you measured (click  to hide or show this pop-up).

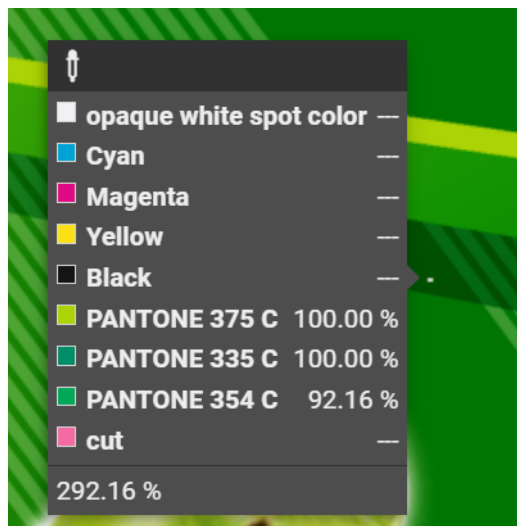

At the bottom, the widget also mentions the TAC of the measured point or area (here 292,16 %). Note that there is a dedicated tool to check TAC. Learn more in [Total Area Coverage](#) on page 1111.

When measuring RIP'ed data (digital film set), you can change the units in the widget (or use **Ctrl - U**).

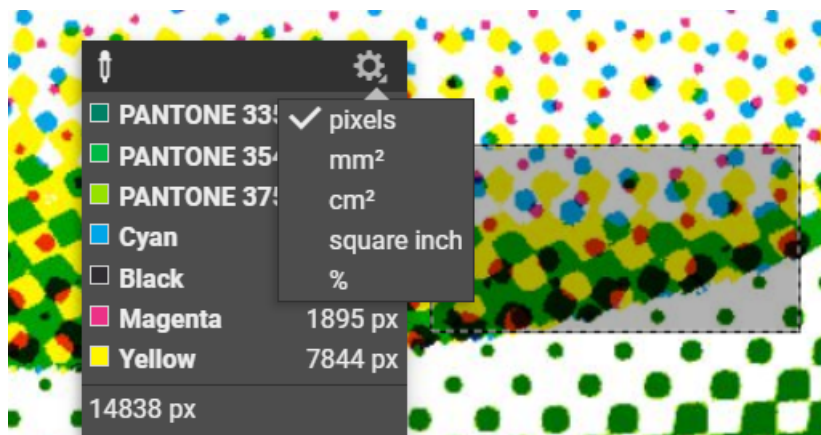

### Calculate Screen Ruling and Angle



**Note:** Before AE 23.07, this tool only works for RIP'ed data. Learn more in [Working with RIP data](#) on page 1133.



**Note:** This tool is disabled when you are comparing files of which at least one is not RIP'ed data (a PDF for example).



**Restriction:** In the selected area, this tool uses mathematical image estimation techniques to calculate dominant frequencies and angles. It does not rely directly on stored meta-data to produce a result which enables it to also detect if there is a discrepancy between the stated (expected) ruling and what is actually found in the bitmap file.

This results in these limitations:

- The density of the measured area must be roughly between 5 and 95%.
- Low rulings cannot be measured accurately. The higher the resolution, the higher the ruling must be for this tool to measure accurately.

Esko recommends that you manually check an unexpected ruling or angle readout with the [Ruler](#) tool.



### Check Barcodes



**Note:** This tool uses technology from the company GlobalVision.

Click the  **Check Barcodes** tool to detect and check 1D/Linear, QR or Data Matrix codes.

The tool scans the selected area similar to how an actual barcode scanner would.

To check a barcode, click  to activate the tool and use the left mouse button to click-drag-release a rectangle around the barcode. Alternatively, you can first select an area and then click .

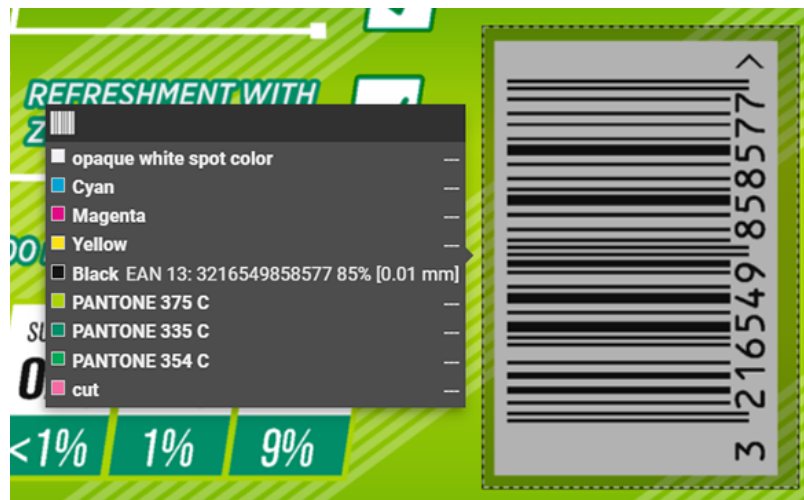

The result appears in a widget near the barcode and also in the [Channels tool](#) on page 1105.

It shows this information (for a valid 1D/Linear barcode):

- **Type:** The barcode type.
- **Value:** The encoded value.
- **Magnification:** The barcode magnification in % (only visible when the value is not 100%).
- **Bar Width Reduction:** The line width compensation in mm (only visible when the value is not 0).



**Note:** When the area you selected contains more than one barcode, the check will only show the result of one barcode.



**Note:** When checking rotated barcodes, make sure the selected area contains the complete barcode.

### Note on measuring Bar Width Reduction (BWR)

The measured BWR can be slightly different from what was entered when creating the barcode. This is due to the resolution of the pixel data that are being measured. Typically, a difference in width of 1 pixel causes a different result, both in this Viewer and when using the [Inspect Barcodes task](#).

This table shows the maximum deviation that can occur when measuring BWR:

	Automation Engine Viewer		Inspect Barcodes task	
	Without prepared view data	Prepared view data at 600 ppi	600 ppi	300 ppi
Max. dev. (mm)	0.0300	0.0125	0.0100	0.0110

### Note on reading Pharma codes

A Pharma barcode can be read in 2 possible directions.

When using this 'Inspect Barcodes' tool, it will show 2 values. Next to those values, an arrow indicates which direction was used to measure:

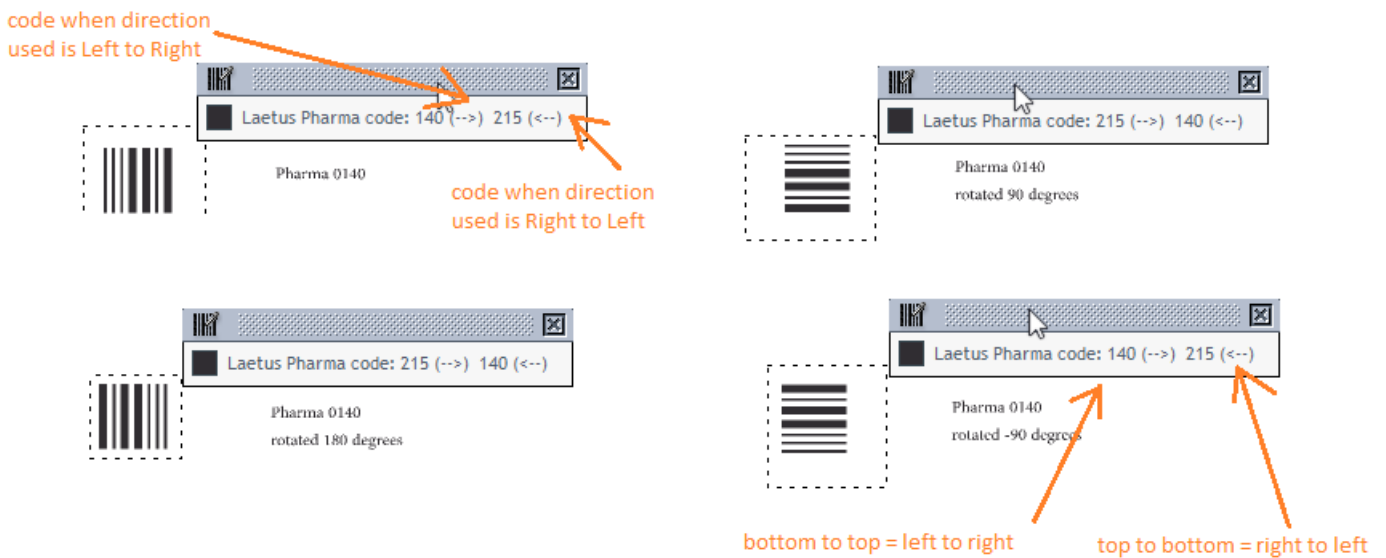

When a Pharma barcode is placed vertically,

- 'Top to bottom' equals 'right to left' when you would rotate the barcode 90 degrees CW.
- 'Bottom to top' equals 'left to right' when you would rotate the barcode 90 degrees CCW.

### Check Braille



**Note:** This tool uses technology from the company GlobalVision.

Use the **Check Braille** tool to detect and translate braille from a selected language.

To check braille, click to activate the tool and use the left mouse button to click-drag-release a rectangle around the braille. Alternatively, you can first select an area and then click .

The result appears in a widget near the braille and also in the [Channels panel](#).

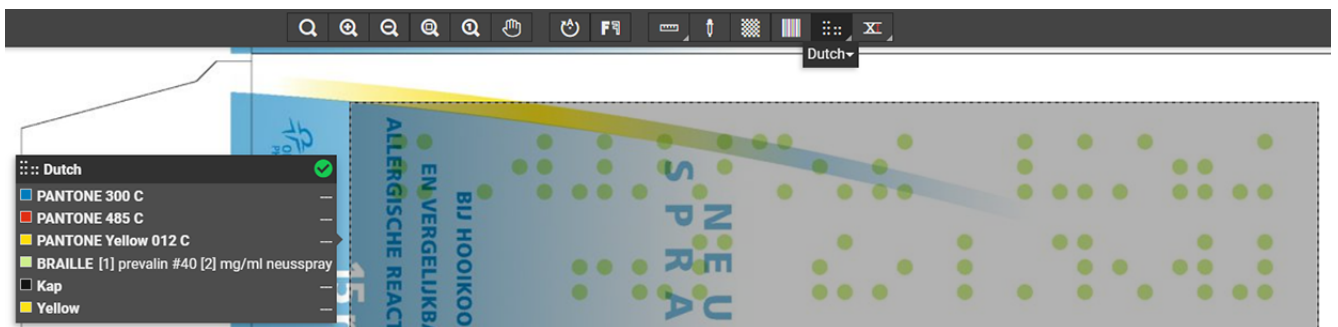

When the braille contains multiple lines of text, the result in the widget will show a line number in square brackets before the text of each line. See the 2 lines in above example.

When the selected area contains more than one block of braille, the results from all blocks will be shown. An extra number will indicate the number of the block.

### Language selection

Braille is written in a specific language. The translation therefore depends on which language the braille was originally coded in.

Click  to select that language from the list that appears below. You can choose to do this before or after you measured the braille.

### Measure Heights and Widths with a Caliper

#### Concept

Use the caliper tool to measure the height or width of multiple, typically aligned, (text) objects. You can measure freely or you can use fixed preset sizes.

Click  to activate it and start measuring using the last chosen style.

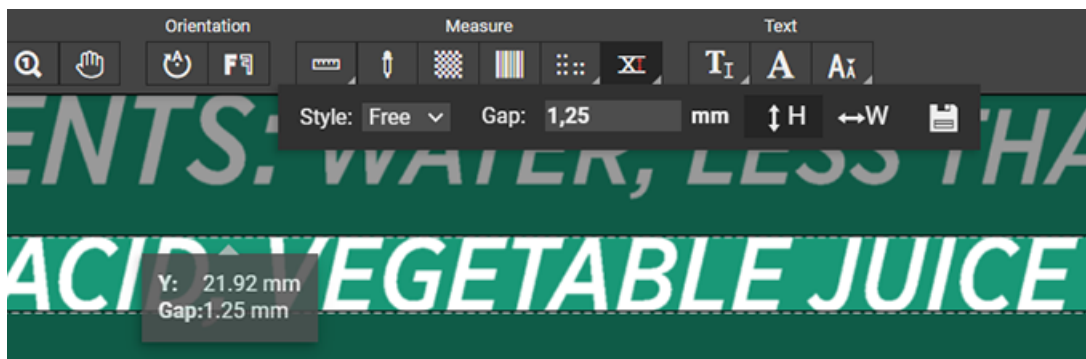

From the caliper tool's sub tool bar, you can:

- Select the **Style** of the caliper's **Gap** (the distance between the start and end line):
  - **Free**: Changing the gap size will alter the end line (default). Learn more below.
  - **Fixed**: A fixed distance between the start and end line. Learn more below.
  - **Preset**: Select a gap size you saved earlier. Learn more below.
- The caliper's orientation can be vertical (the gap is the **Width**) or horizontal (the gap is the **Height**).
- Click the **Save** icon to add this caliper to the list of **Style** presets. Once you have saved presets, an extra icon appears to delete the selected one.

#### How to measure

- **Free Style measuring** (default)
  - After activating the tool, click a first point of measurement in the view.
  - Move or drag the mouse to a second point.



**Tip:** You can use all zoom, scroll and pan tools while you are navigating to the first or second point.

- Click the second point. While moving the mouse, a pop-up displays the current gap size and the X or Y coordinate.

When releasing the mouse, the area outside the selection will be dimmed to highlight the selected area:

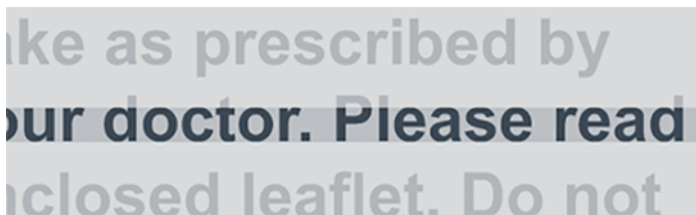

To adjust the width or height, simply drag the lines that appeared. Click between the lines to move the caliper selection (both lines).

• **Fixed Style measuring**

Use a fixed gap size when you want to check (text) objects versus a pre-determined size. For example, when a specific text height is required in that document, specify that as the gap size and check the artwork text (alternatively, use the dedicated text tool **A<sub>i</sub>** to measure font size for example).

- Activate the caliper tool, select style **Fixed**, now specify the **Gap** size and select an orientation.
- Click anywhere in the view to see the caliper appear. In this fixed style, your mouse movement will not alter the caliper orientation.
- When you think you will measure this gap again, consider saving the preset.

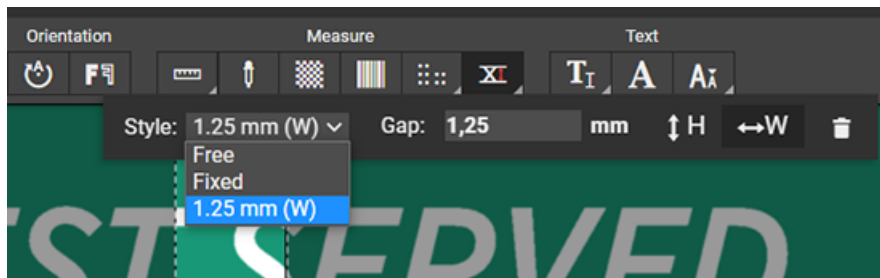

**Note:** Press **Esc** to revert to the tool's initial state (no caliper lines drawn).



**Measure Text**

The top tools bar offers 3 tools to help check the text in the open document(s).

These tools are available for PDF and AI files.

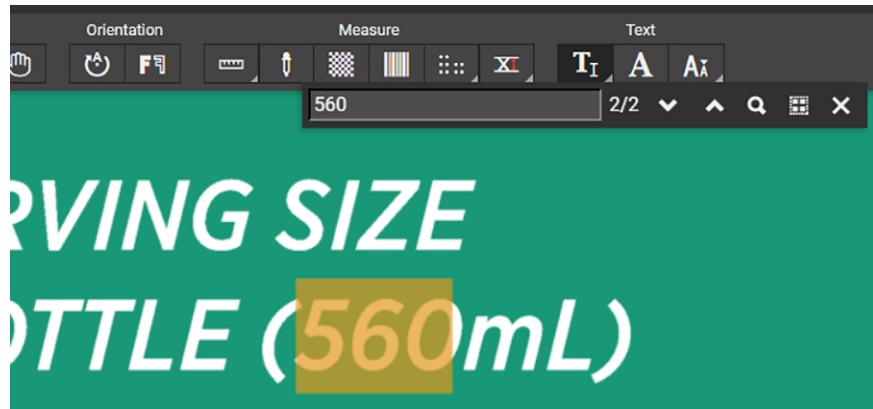
- The **Select Text** tool
  - Click **T<sub>I</sub>** to activate this tool. It will open a sub tool bar.



- To **Search in text**, type in the text field and press **Enter**. The number shows how many times this value was found. Click the next / previous **▼ ▲** buttons to navigate and zoom in to these results. The current find is highlighted in orange, any others in blue.
- To **Select all text** in the document, click  (or use **Ctrl+A**).
- The **Detect Font** tool
  - Click  to activate the tool.
  - Then click on or hover over a piece of text. A pop-up shows the results: the Font, Font Size and the selected text.

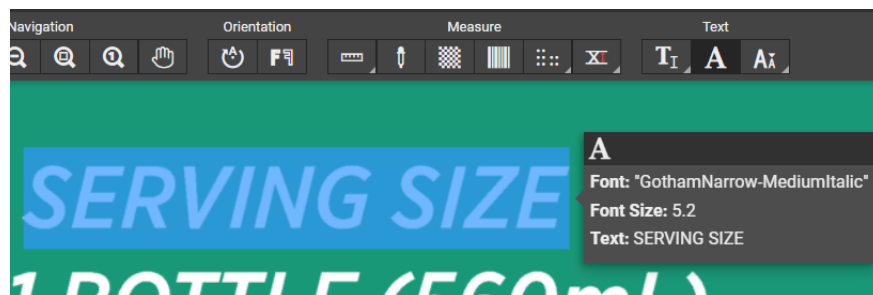



When selecting or hovering over an object that is not a text object, the pop-up will mention "No font information is found. Your text may be outlined".

- The **Check Font Sizes** tool
  - Click  to activate this tool. It will open a sub tool bar.
  - Type a **Minimum Font Size** (or use the slider). The tool will select all text that is smaller than the selected font size.

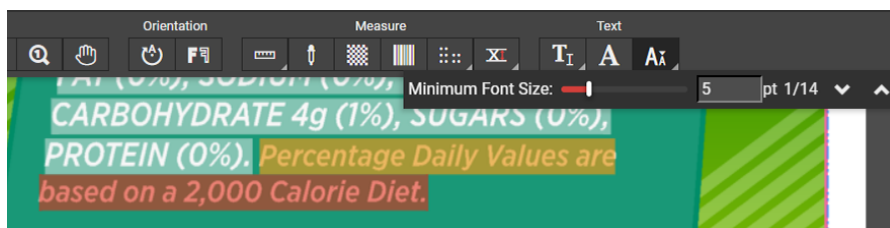



- Click the next / previous   buttons to navigate and zoom in to these results. The current find is highlighted in orange, any others in blue.

## Print

The print tool enables sharing visual information to people that do not have access to this Viewer.

Click  and first select which **type** of output you want:

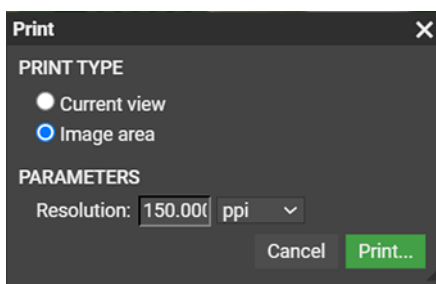

- **Current view** (default)

Select this mode when you want the entire view area to be printed. Your print preview will contain:

- all panels in the split view mode with borders
- visible ruler end point and read-outs.

The resulting print preview changes the background color and the titles of the windows to white.

If only some of the channels are selected, you will see the extra option to **Print only selected channels**.

- **Image area**

Choose this mode to get a clean print of the current document page without visible ruler end points or ruler read-outs. When multiple windows are active, either the composite of all the channels or the selected channels will be printed.

This mode offers these options:

- **Resolution:** Specify the resolution and its units (ppmm = pixels per millimeter, ppcm = pixels per centimeter or ppi = pixels per inch). The default value is 150 ppi converted to ppmm.
- **Print Current View :** Enable this to print only the current view area. Do not select this when you want to print the entire document.

- Also here, if only some of the channels are selected, you will see the extra option to **Print only selected channels**.

### 15.2.5. Navigator tool

In the right sidebar, click  to open (or close) the **Navigator**.

This widget shows a thumbnail of the open document and highlights the current view area.

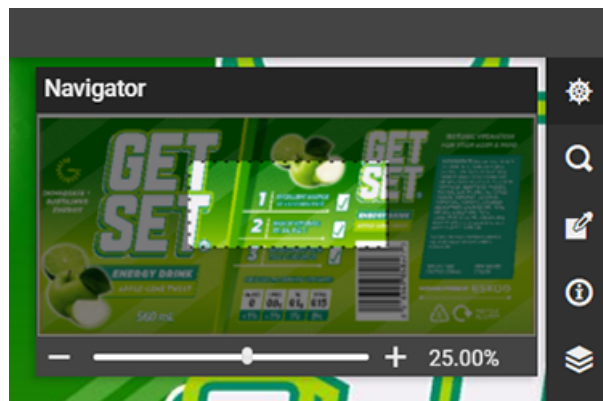

Use this widget to quickly navigate through the document:

- To pan through the document, hold the mouse and drag the highlighted rectangle around. The main view area will follow accordingly.
- Use **CTRL - 'arrow'** to pan in that direction, including an overlap.
- Click outside the highlighted rectangle to move it to that point (as its new center).
- Below the thumbnail, notice the slider indicating the current zoom level. Use the slider or click the **+** or **-** to change the zoom level.



**Note:** By default, this widget is available on the right sidebar. You can drag this widget to another sidebar.

### 15.2.6. View tool

In the side tool bar, click  to open (or close) the **View** widget.

It offers 4 extra tools which, when you select or hover over them, open a sub tools bar or show tooltips.

#### Change Background Color of Image or Window

You can use this tool to manipulate the view with a different background color other than white. This is especially useful when you are evaluating a document that will be printed on a colored background that will have its effect on that final print.

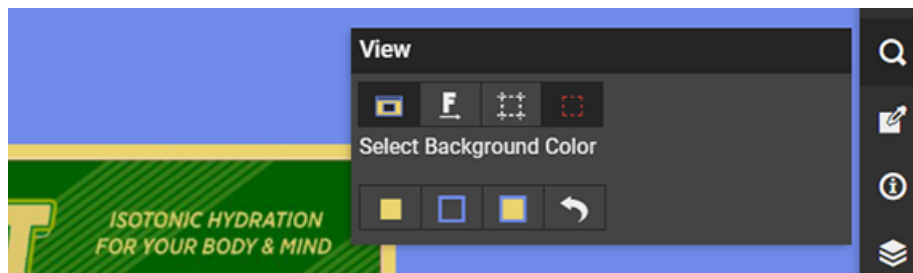

This tool offers several buttons to change a background color that you can pick from a color picker. From left to right:

- **Change Image Background Color.** In above example, the white background in our document ('image') was changed to some kind of beige.
- **Change Window Background Color.** In above example, the black was changed to a clear blue, so re-introducing a better contrast with the beige in the document's borders.
- **Change Both Image and Window Background Color.** They then have the same color.
- **Reset Background Colors** to their default color. Closing this  tool has the same effect.



**Tip:** To close a color picker, just click somewhere outside of it.

### View From Back



Use this tool to mirror the view / see the document from the back. Also the channel sequence will be reversed.

This is a useful when inspecting a document that will be printed on a transparent substrate.

### Show/Hide Margins (Trim Box)

The trim box is often used as the basis for step & repeat of a one-up. It is good practice that the trim box corresponds to the bounding box of the die line.

Click to hide or show the margins (trim box). These are by default shown in a thin blue dashed line (in the screenshot below, we've hidden all channels to make sure you can see them).

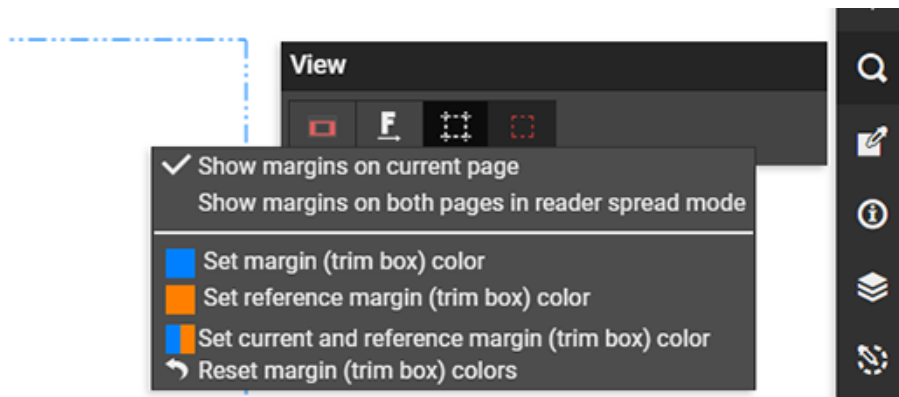

Right-click  for these options:

- **Show margins on current page**
- **Show margins on both pages in reader spread mode.** Useful when working with multi-page files.
- **Set margin (trim box) color:** To set the color of the margins to a different color than the standard blue. When in comparison mode, this is the 'current' document.
- **Set reference margin (trim box) color:** When in *comparison mode*, use this to set the color of the margins of the 'reference' document.
- **Set current and reference margin color:** When in *comparison mode*, use this to set the color of the margins of both documents.
- **Reset margin colors:** Sets the Viewer's default color for margins.



**Note:** When the document has no trim box, the margin lines will follow the document outline (media box).

### Clip Document to Margin (Trim Box)

Do you want the Viewer to show you what is outside the trim box? (not active)

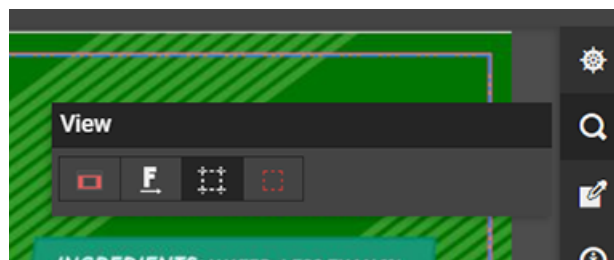

Or do you want the Viewer to clip that away from the view? (active)

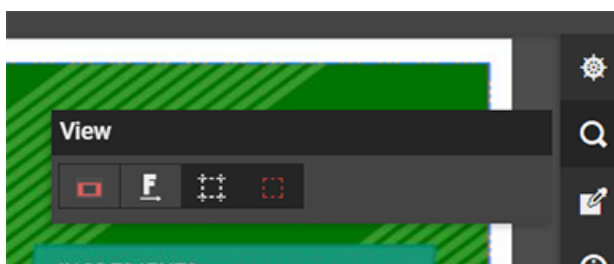

Right-click  to see the extra option to **Clip Document to Margin (Trim Box) in reader spread mode only**. Learn more in [Working with Multi-Page Files](#) on page 1143.

### Ruler

Click this tool to show or hide a ruler at the top and left side of your view.

### Seamless View

Click this tool to activate an automatic simulation of a seamless layout of the open PDF or RIP'ed data.

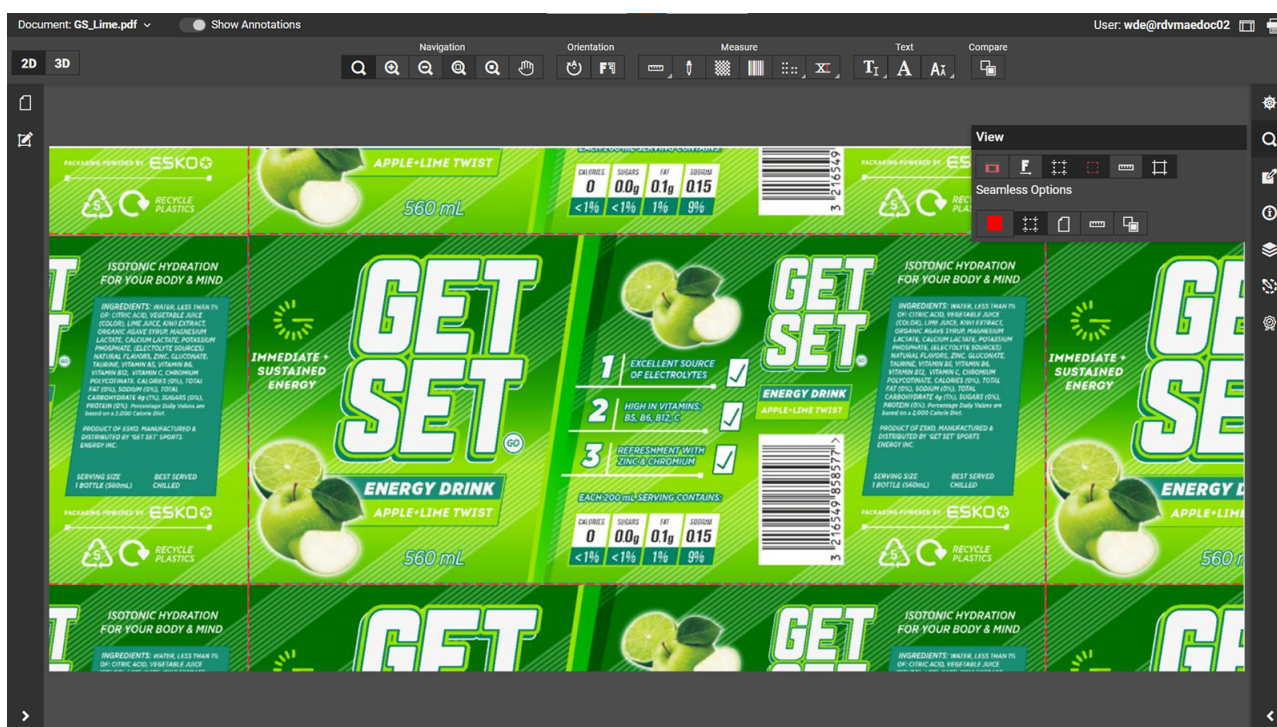

The main use case for this tool is to check 'seamless design', i.e.: will that pattern, when printed, nicely continue on the other side. For example: wallpaper.



**Restriction:** This tool can only simulate a seamless layout automatically or manually (see below). You can **not** define seamless layouts **numerically**, for example by defining plate or cylinder measurements or to simulate/check staggered layouts. This can be done however in the editor ArtPro+.



**Note:** This tool can also be used to check the result when data was RIP'ed to screened separations with the option '*seamless screening*'. When viewing such data here and asking the seamless view you should then see that the dots really do align. An example:

- Zoom in to a seamless view of a file RIP'ed without seamless screening:

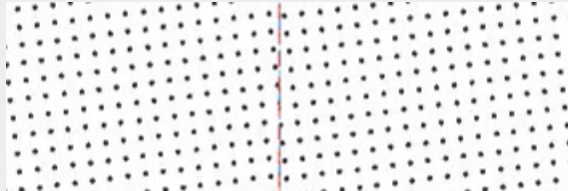

- Zoom in to a seamless view of a file RIP'ed with seamless screening:

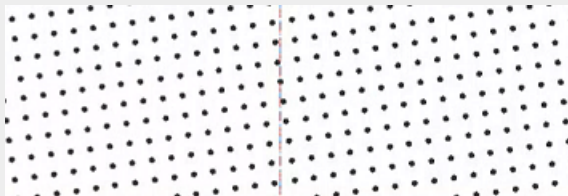

**Seamless Options:**

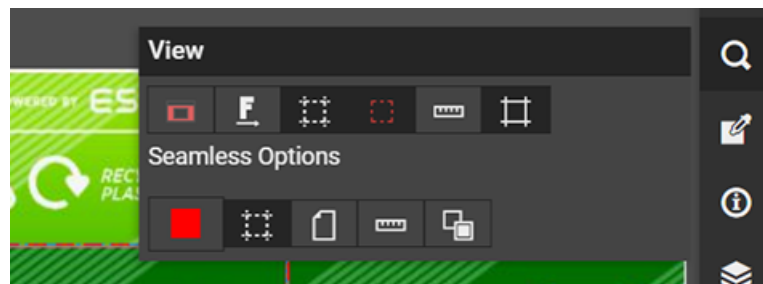

- : To pick a different color for the lines visualizing the seam.
- : To show or hide these lines.
- : To define which page box needs to be used as base for this view. By default this is the trim box.
- : To make a custom seamless box by making use of the ruler guides. Follow these steps:
  1. Make sure the general ruler tool is activated (button to the left of the one for seamless view)
  2. Also activate the ruler button in the Seamless Options.
  3.
    - In the left side ruler, click a first and second new top and bottom of the seamless box you want.
    - And/or, in the top side ruler, click a first and second new left and right side of the seamless box you want.
  4. The view automatically adapts once you clicked a second guide in either orientation.
- : Activate this to allow some overlap (2 mm), instead of clipping on the seamless box. This can make some gaps disappear.

## 15.2.7. Channels tool

### Intro

Click  to open (or close) the **Channels** widget. It shows the document's channels (separations, inks) and offers extensive separation viewing possibilities.

You can switch channels off and on. You can change their display color and transparency. You can map channels so they here appear as one.

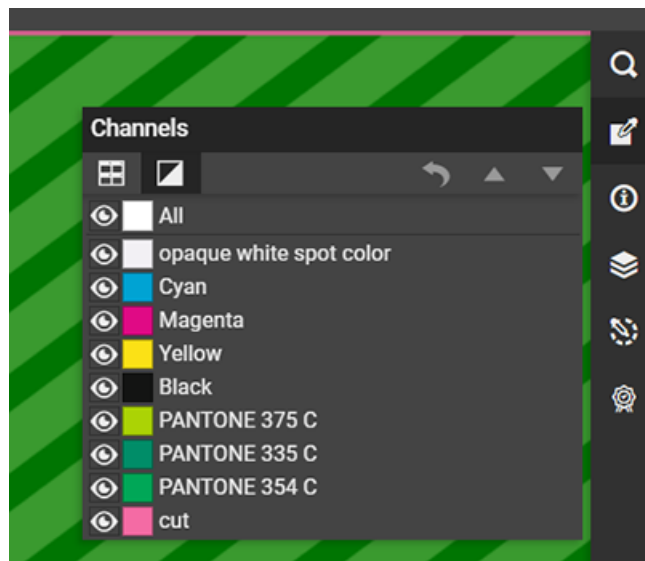



Especially when comparing files based on their channels, it is important to know the exact definition of the channels.

A channel is defined by

- its name
- its RGB display values
- its ruling, angle and dot shape (when defined as a screen set).

### Composite or ...

- Click  to switch between a single **Composite view** and a tiled view of all (selected) individual channels (and 1 composite).
- Right-click  to choose the kind of tiling to use: **Automatic**, **Horizontal** or **Vertical**.

### Show/ Hide Channels

Click  to show or hide one, multiple or all channels.

Right-click the  of a single channel to view only this channel (any others will be switched off).



### Changing the Appearance of a Channel

Click a channel's color patch to open its **Channel Colors** widget.

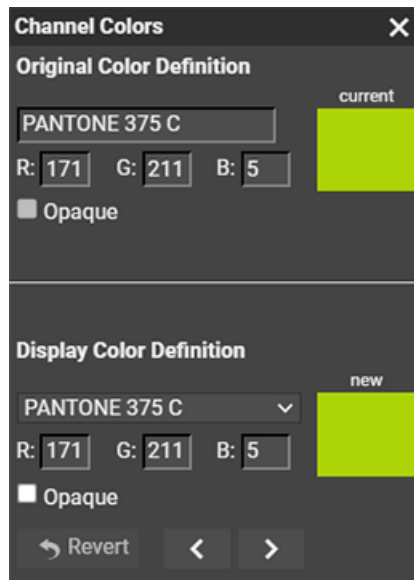



The top part shows the **Original Color Definition** and is read-only.

The bottom part allows you to change the way the channel is displayed. This is for example useful when the file contains a white separation because it will be printed on clear plastic. To see that separation better in the Viewer, you might want to display it as pink for example.

- To set another **Display Color**, you can either
  - set new RGB values
  - click the color patch to pick a color
  - in the name, use the drop-down list to choose a same color of another channel in this document.
- Select **Opaque** to make the Viewer display this channel as opaque.



**Note:** These display changes are not remembered the next time you open this file in the Viewer.

- Use the   arrows at the bottom to browse to the definition of another channel, which allows you to modify several channels without reopening this dialog.
- Click  to revert to reset the display to the channel's original color definition.
- The name of a channel of which you changed the display is in the Channels widget marked with an asterisk (\*)

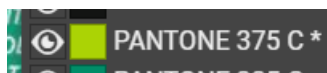

### Changing how Single Channels are Displayed

Click  to display a single channel in black instead of its own color.





**Note:** This setting is remembered the next time you open the Viewer.

A right-click on also offers to **show single channel as black with 'show all' effect**. This view uses black rather than a grey value for a display pixel that represents a partially covered area. This makes it easier to detect areas with small dots in RIP'ed files. An example:

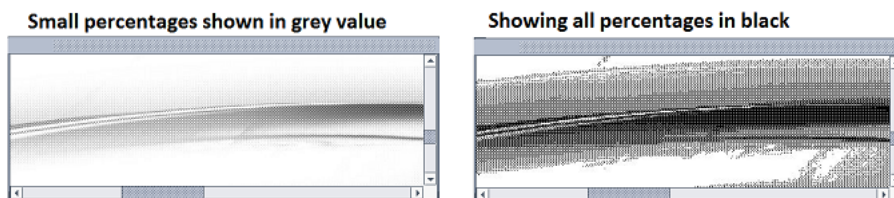

### Changing the Sequence of the Channels

When printing, opaque inks cover previously printed inks. This is why the sequence in which you view channels is also important.

You can change their display sequence by using the buttons or by click-and-dragging one's name or color patch to a different position.

Moving a channel **down** means putting it **later in the printing** sequence, so being printed on top of the channels above.



**Important:** This display sequence does not have any influence on the actual printing sequence, it only affects the display in the Viewer.

When you have changed the channel sequence, click on to **Revert** to the original channel sequence. Right-click to choose what you are resetting: only the **channel order**, only the **color definitions** or **both**.

### When Comparing Files that have Different Channels

Learn about comparing in [Comparing Files](#) on page 1117. We here only mention the extra symbols that can occur next to a channel name.

The **Channels** panel shows you when the compared files have different channels:





- **(+)** means that the channel is only present in the current (first) file.
- **(-)** means that the channel is only present in the reference (second) file.

Alternatively, you can also use the [Compare HSV mode](#) to compare files with non-matching channels.

### 15.2.8. CAD tool

Click  to open the CAD widget. It will only appear in the tool bar when you opened an ARD or MFG structural design file.

The tool shows the CAD layers in the document. Use the regular  tools to show or hide layers.

Open its  settings allows to

- show or hide specific types of lines (nicks and bridges)
- show the names of the one-ups (if any present).
- to lighten the visualisation of any graphics data (if any present).

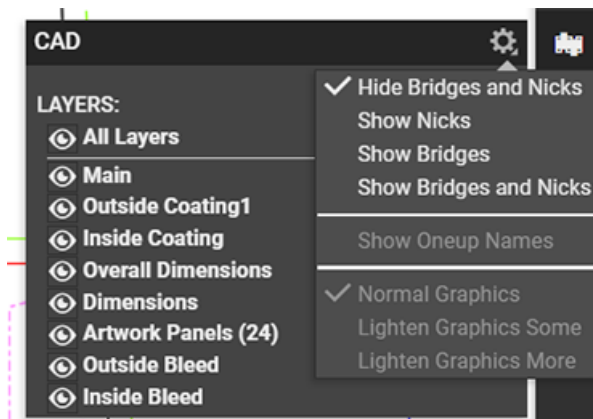

### 15.2.9. Info tool

This widget displays following information about the (active) document:

- the size of the document
- the size of the trim box of the current page
- the current mouse position
- the current selected area when using measuring tools.

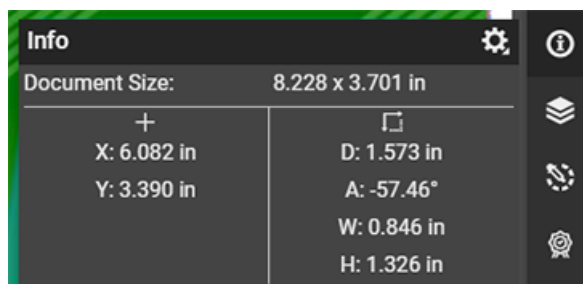

Click  to select your preferred units. These will be used for all measurements during the current viewing session.



**Note:** More information about the open file is available when you open the file's Info dialog ( in the top tool bar).





### 15.2.10. Layers tool

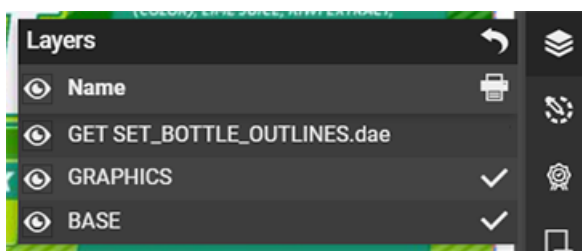

**Note:** The **Layers** widget is only shown when the document has layers.



#### Show / Hide Layers

- Click  to show or hide a layer.
- Click  next to the title 'Name' to switch all layers on or off. There will always be one shown, by default the top one.
- Right-click the  of a single layer to view only this layer ; all others will be switched off.
- When only one layer is shown, and you choose to hide it, the next layer (below) will be shown.
- Click  to reset all changes ; i.e. show all layers.

#### Printing State

The column under  indicates the **Printing state** of that layer.

See in above example how the printing state of the layer containing the 3D object was set to non-printing in ArtPro+.

### 15.2.11. Color Management tool

This tool enables the display of a PDF to be color managed to make it resemble more like the printed result.

Click  to open the widget.

1. Select **Enable Color Management** to make the widget load the available profiles and list them below.

The profiles shown in that list are the same that an ArtPro+ editor will offer when connected to this server: all standard and any custom ICC profiles stored centrally in their default folder `bg_data_cms_v010/w/icc`.

The default profile is the one defined in the PDF as **Output Intent**.

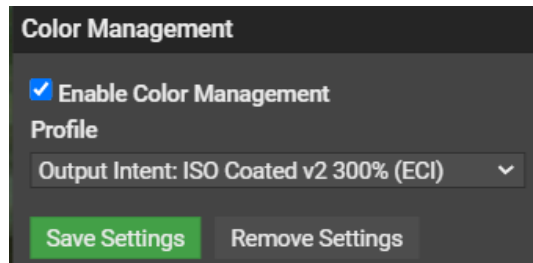

2. Now select the wanted color **Profile**. The Viewer will immediately visualize the described colors accordingly.

This selection stays active during the current viewing session (in that tab of the browser).

Click **Save Settings** to save the activation of the selected profile with that file. It will be re-used the next time any one views this file in this Viewer.

This setting is stored as metadata next to the file, until someone clicks **Remove Settings**.



**Note:** In a color managed view every zoom and pan operation will be 0.5 sec slower.

## 15.2.12. Quality Control tools

Click  to open the Quality Control widget.

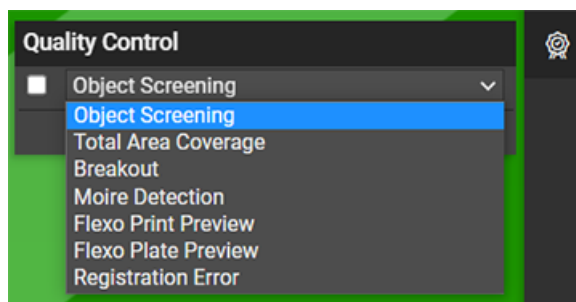

Selecting a tool from the list shows its options and also automatically activates it.

While a tool is activated , you can de-activate it: .

### Object Screening

When the Viewer is using the latest technology, activating this tool shows a list of all Screen Sets used in your file, each with a different color.

Objects using a specific screen set will show in the corresponding color. Click the color patch to customise it.

Areas where multiple screen sets overlap are highlighted in red.



**Note:** Only screening conflicts involving **overprint** are highlighted. Blend modes are not taken into account.



• **Screening Model**

- **Esko** (default): Separation based screening (i.e. per ink) ; the method as used in the classic Esko FlexRip.
- **Adobe**: Object based screening ; the Adobe PDF RIP method as used in Esko Imaging Engine.

Learn more about these screening models in the [chapter on Imaging Engine](#) or the [ArtPro+ user guide](#).

**Total Area Coverage**

The Total Area Coverage (TAC) tool helps to identify areas where the total amount of ink in the selected channels is higher than a given percentage.

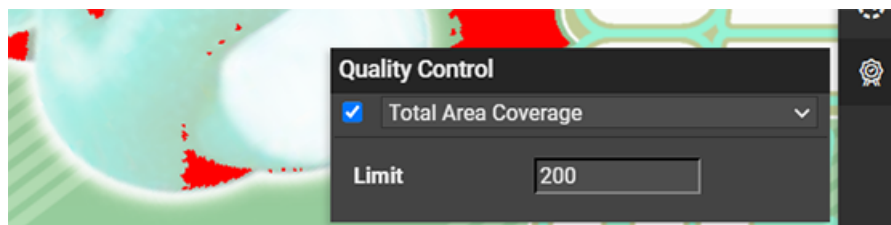

Once the Total Area Coverage tool is activated, the image in the Viewer is dimmed and areas where the sum of the densities is higher than the specified TAC **Limit** are highlighted in red.

You can set the limit to a percentage between 0 and 500%. You can as well use your arrow keys to increase/decrease this value (by steps of 10%).



**Note:** Invisible layers, invisible separations and 'technical inks' are not taken into account.



**Important:** The TAC values shown here can differ from those shown in ArtPro+. This is because the Viewer does not include processing step separations when calculating the TAC.

### Breakout

In flexo printing, the **Breakout** tool helps to locate areas where the percentage of a single separation is lower than the first visible dot, indicating the risk that it will not be possible to print. Press **Enter** to trigger the calculation.

The image is dimmed and the areas below the set **Limit** are shown in red.

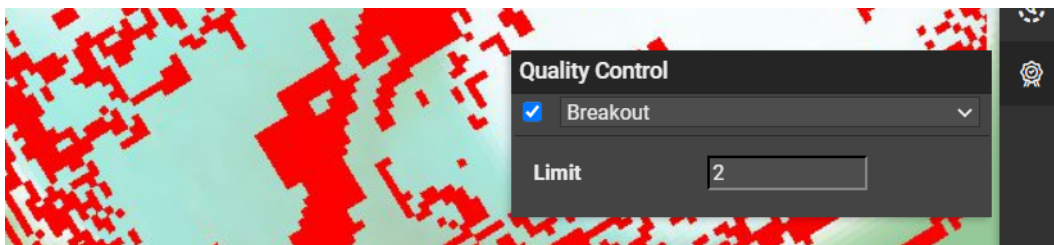

**Note:** Values are rounded off to the closest system value (n/255 in %): 0%, 0.4%, 0.8%, etc.

If you enter 0.8% as first visible dot, you will only see breakouts for values that are rounded off to 0.4%.

If you enter 0.4% as first visible dot, no breakouts can be shown. We advise to only enter 0.4% if you are sure that your device can print values as low as 0.4%. It is only for such devices that the Breakout Quality Control with first printable dot set to 0.4% will correctly confirm that everything is printable.



**Tip:** While this tool is active, you can still use the densitometer to measure the actual percentages.



**Note:** Invisible layers, invisible separations and 'technical inks' are not taken into account.

### Moiré Detection

Use the **Moiré Detection** tool to detect possible screening problems in your document.

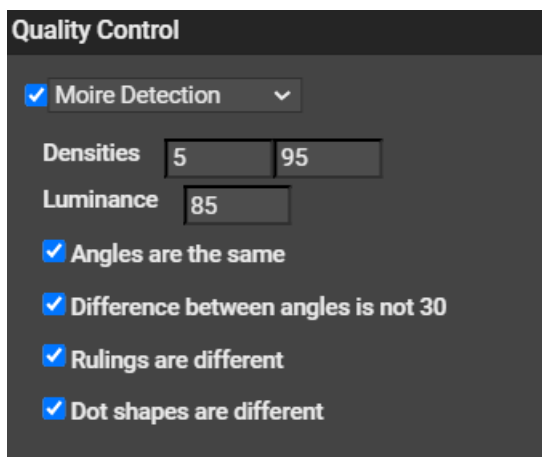

When you activate Moiré Detection, the document is shown dimmed and areas with possible screening problems are highlighted in red.



**Note:** All visible channels are taken into account.

- First define which printing areas this tool should take into account to do its checks.
  - **Densities:** Areas with a density lower and areas with a higher than these values will be highlighted. Default values are default 5,1% and 94,9%.
  - **Luminance:** Areas with a luminance value higher than this value will be highlighted.
- Then select which types of screening problem this tool should detect in those printing areas:
  - The angles for the separations used in that area are the same. Also if they differ a multiple of 90°. For example an angle of 7,5° and an angle of 97,5°.
  - Or these angles do not differ 30 degrees.
  - The rulings for the separations used in that area are different.
  - The dot shapes for the separations used in that area are different.

### Flexo Print Preview

This tool helps to predict the effect of the flexo printing process in the highlight areas by applying a non-linear curve to the selected channels. The effect is shown immediately.

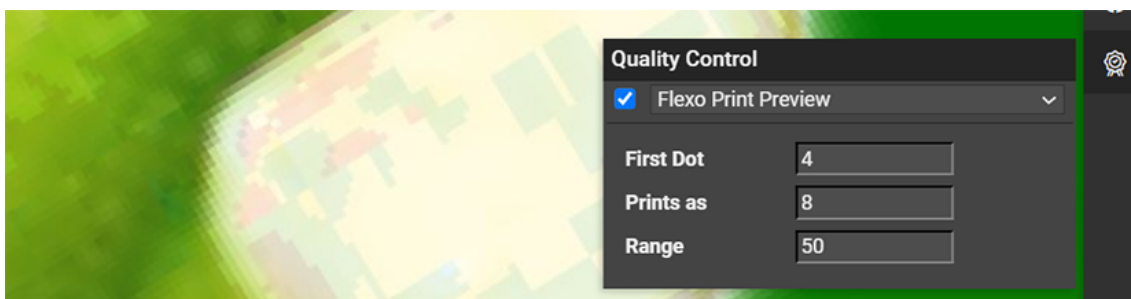

The curve has three adjustable parameters:

- **First Dot:** Below this value the output is zero (aka the "breakout" value) ; this is the first visible dot percentage. This means that you expect it will technically not be possible to print smaller values than this one.
- **Print as:** This is the real output value at the first visible dot percentage. This value is typically somewhat higher than the percentage of the first visible dot, so creating what is typically called a bump-up effect.
- **Range:** This is the highest affected input value. Between the First visible Dot and the Range percentage, the effect of the bump-up is linearly decreasing. Percentages above this value are displayed unchanged.



**Note:** Invisible layers, invisible separations and 'technical inks' are not taken into account.

### Flexo Plate Preview

This tool simulates how the selected channel would look when it was imaged on a flexo plate.

This simulation is characterized by a **First Dot** percentage and by a **Plate** color selection.

An example using Cyrel Red to simulate the flexo plate:

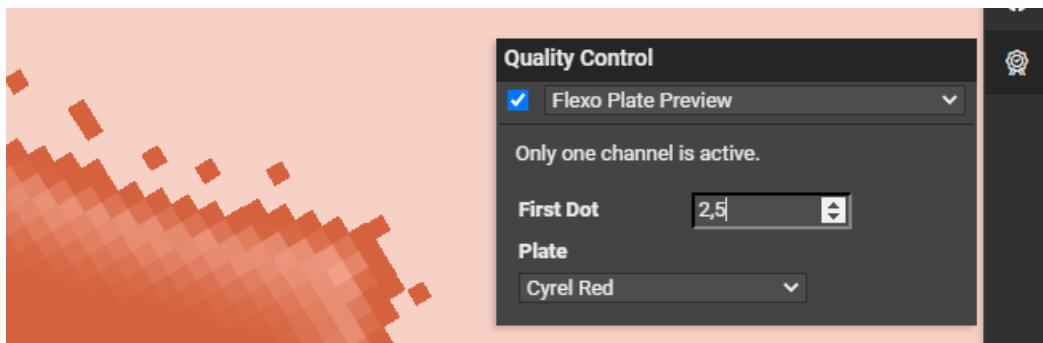

**Note:** This mode is possible when viewing single channels but also when using "View channels in separate windows".

To change the **First Dot** percentage, click the value and enter a new percentage or use the slider that pops up.

To change the **Plate** color, pick one from the dropdown list.

### Registration Error

This tool simulates the effect of print registration errors by randomly offsetting the visible channels by a specified distance (the **Deviation**). The effect is shown immediately.

This simulation for example helps to check if the trapping is sufficient.



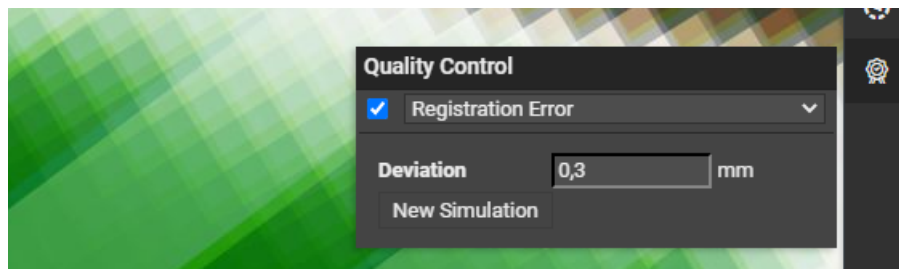

Here is an example when viewing a digital film set:



- **Deviation:** Change this value and press Enter to have the effect calculated and shown immediately.



**Tip:** This tool allows using zoom and pan tools to visually inspect the effects of a given registration error on different parts of the design.

- **New Simulation:** The tool randomly shifts all channels with the given distance, but all under a random angle.

If you want to see another random simulation, click **New Simulation**.

### Show as Print

When RIP'ed data was created with options **invert** (negative) and/or **mirror** (wrong-reading), the AE Viewer will by default show them as they were RIP'ed, i.e. as the files really are. An example:



When you select **Show as print**, the AE Viewer shows the digital film set as it will look when printed.



**Note:** This is the same behavior as the *(old technology) Java-based Viewer* had.

### Show Plate Cut

When the Viewer is using the latest technology, this tool is available when you open a LEN(x) file originating from a PDF+ layout with plate cut paths or from a PDFPLA layout with a staggered cut path.

When viewing a single channel, activating this tool shows the plate cut path as a red line, on top of the information in that selected channel.

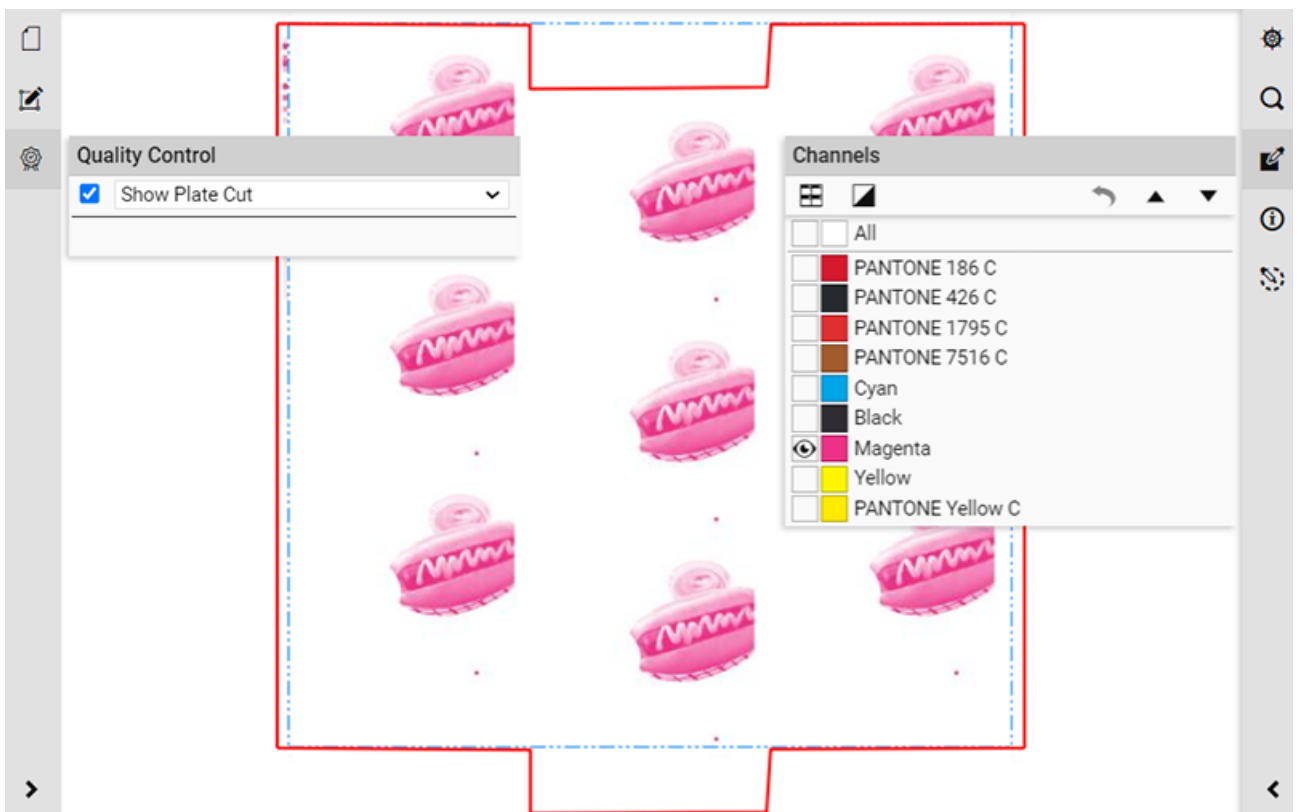

A plate cut path can be different per channel.

### Highlight Small Dots

When the Viewer is using the latest technology, this tool is available when opening LEN(X) files.

Activate the tool to highlight dots with less than 2% density in red. Other selected channels will be shown in black.

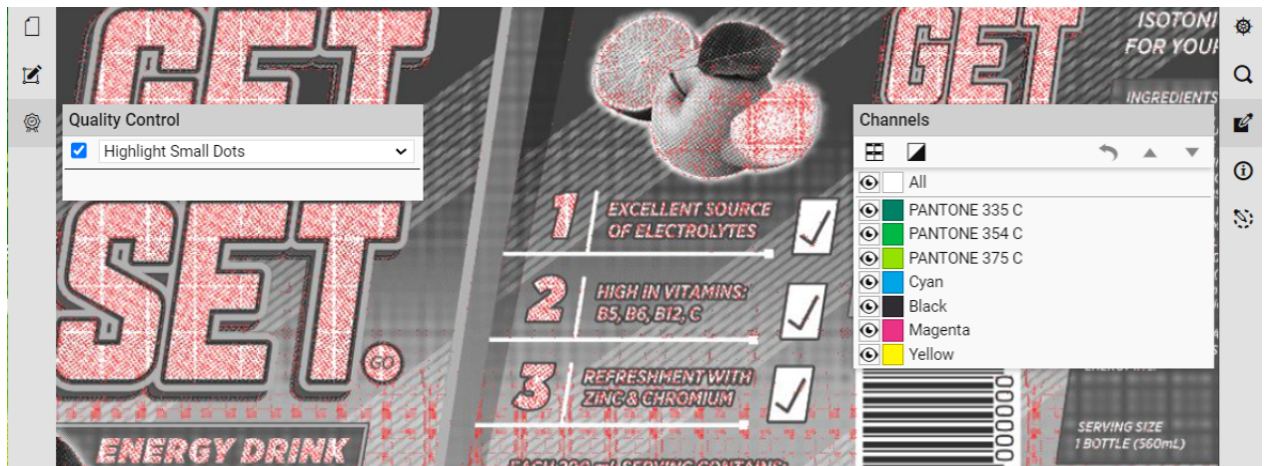

## 15.2.13. Comparing Files

### Intro

#### Extensive and Powerful Tools

The Viewer allows to compare two files and inspect their differences.





**Restriction:** When the two file types use a different viewer technology, you will not be able to compare them. Learn about viewer technologies in [here](#).

- The Viewer also allows to compare **files of a different type**. For example comparing a (PDF compatible) AI design with its final production PDF. Or comparing a one-up PDF with its Step & Repeat version, or even with its RIP'ed version.
- The Viewer also allows to compare **files of a different size**. They can have a different trim box, or even a one-up compared with its layout.
- And while in compare mode, all **other tools also still work** (navigate, measure, channel selection, color management, quality control tools, etc.)
- And apart from comparing channels (separations), the Viewer can **also compare files based on HSV**, i.e. compare colors, much like the human eye or a camera does.

#### How to Start Comparing

There are several ways to start comparing:

- First selecting (file(s) in the client:

- Make your file selection in the client (Pilot or browser), and there choose 'Compare' or 'Compare to'. When these files are not in the same folder, you will need to use 'Use selection for Compare' and then browse. Learn more in [The Files View](#) on page 115.
- Selecting the files from within the Viewer:
  - In older technology, the Java based Pilot Viewer : To compare files, open a first file ("Current"), then click the  compare button and choose a second file ("Reference") from the dialog.
  - In the latest technology, click the  [compare tool](#) to open the **Select File** pane and there select the second ("Reference") file.

You can stop comparing and close the reference file by selecting **Turn off Comparison** in the [Document Select widget](#).

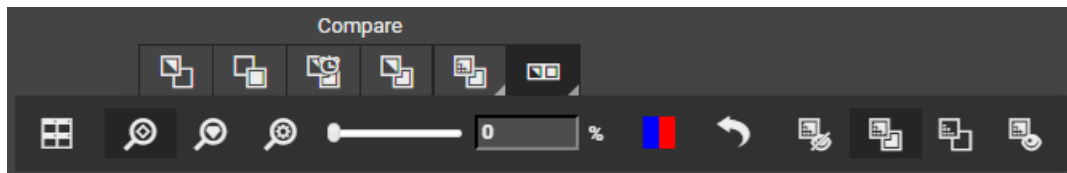

### Compare tools (Top Tools bar)

When comparing files, the top tools bar shows the extensive set of compare tools.





- The top row icons are the comparison view modes: your choices of windows layout when checking differences. Learn more in [View Modes when Comparing](#) on page 1118.
- The ones below are sub tools (options) that appear when choosing of one the last two view modes. Learn more in [Difference View Mode Options](#) on page 1119.

### View Modes when Comparing

-  **View Current Version:** To view only the current version (the file you opened first).
-  **View Reference Version:** To view only the reference version (the file you opened later, to compare).



**Tip:** Use **Ctrl-S** to toggle between the view of the current and the reference file.

-  **View Both - Blinking:** To view a blinking mode that switches the view of each file approximately every second.
-  **View Both - Show On Top:** To view both files on top of each other. This is typically used when the two files together form a complete layout, for example a left and right page of a reader spread. Or when two (similar) variants of a design were created and you want to check how they align.
-  **View Both - Show Difference:** To find or focus on the highlighted differences. Identical data are dimmed and differences are highlighted in the specified highlight colors (see below). This mode is especially useful to spot small differences when zoomed out viewing the entire file or when using the Navigator tool.

Selecting this mode also shows its sub tools to select a different tiling orientation or to decide whether you want to see a third window with the differences. Learn about these options [below](#).

-  **View Both - Side by Side:** To view both files side by side, with an extra 3rd window showing the difference.





Selecting this mode also shows its sub tools as mentioned above and even some extra. Learn about these options [below](#).

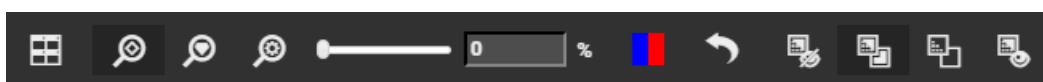

**Tip:** The views in each split window also remain synchronized when you work with channel selection or during navigating, zooming, etc.

### Difference View Mode Options



-  **Tiling mode:** Click to select Automatic, Horizontal or Vertical tiling of the view windows.
-  **Compare: Channels:** This (default) mode shows differences that it finds in channels with identical definitions. It compares Channels one by one. The added and subtracted content is displayed in highlight colors. Learn more in [Matching Channels](#) about how to define if similar channels should be compared or not.
-  **Compare: HSV:** This mode compares colors. It looks at the two files the way your eyes do or as a camera does. For example a green object will not be seen as different even when in the one file it is colored as a PMS color and in the other as an exact same color mix of cyan and yellow.
-  **Compare: Automatic:** With this setting, the 'Channels' mode is used when the definition of all visible channels is equal in the two compared files. When this is not the case, the 'HSV' mode is used.

-  **Difference Threshold:** You can change the level of precision with which differences are detected. Use the slider or enter a percentage value [0-100%]. When the threshold is higher than 0, you will sometimes see a warning about the now possibly hidden differences.



**Note:** The set threshold will be saved for your next compare session.





- : Change the **Highlight Colors**. Depending on the colors in your documents, you may want to change the default blue and red highlight colors.

By default,

- the **added** channels and objects on common channels are displayed in **blue** to highlight the differences (this is the left part of the color block button).
- the **subtracted** channels and deleted objects on common channels are displayed in **red** ((this is the right part of the color block button).

You can:

- **Change 'Added' Highlight Color...**
- **Change 'Subtracted' Highlight Color...**

- **Change Both Highlight Colors.** This will make them use a same color.  
Click on the color patch and select the new color.
- : To revert back to the default highlight colors.
- Choose the **Compare Mode**:
  - : Hide Difference
  - : Show Difference
  - : Show Difference - View Both - Highlight Difference
  - : Show Difference - View Both - Show Difference

**Changing the Difference Threshold**

When comparing files that are not perfectly aligned or that have minor tonal differences, you may want to adjust the threshold on when a difference should be highlighted. This allows you to make a distinction between minor and major differences.

Use the slider or type a percentage in **Difference Threshold**.

Here is an example where the extra scattered pixels disappear when changing the threshold to 10:

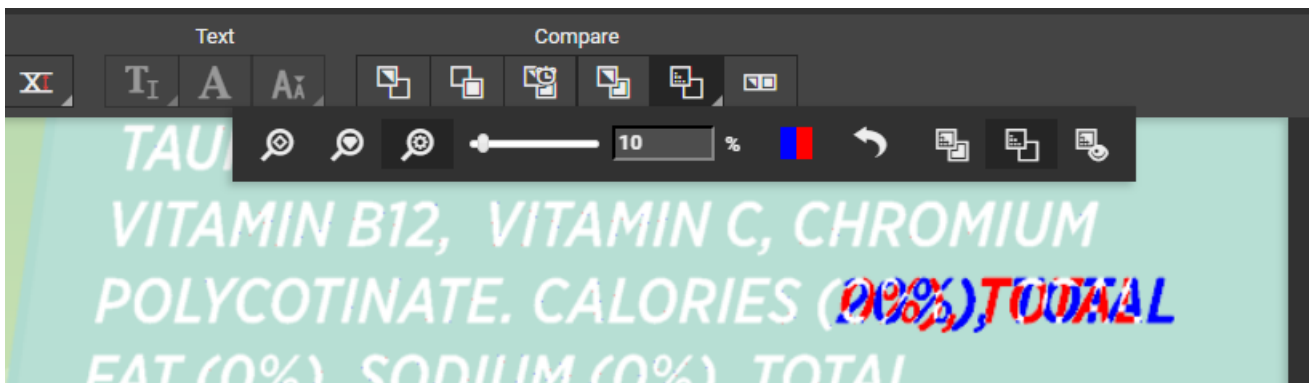
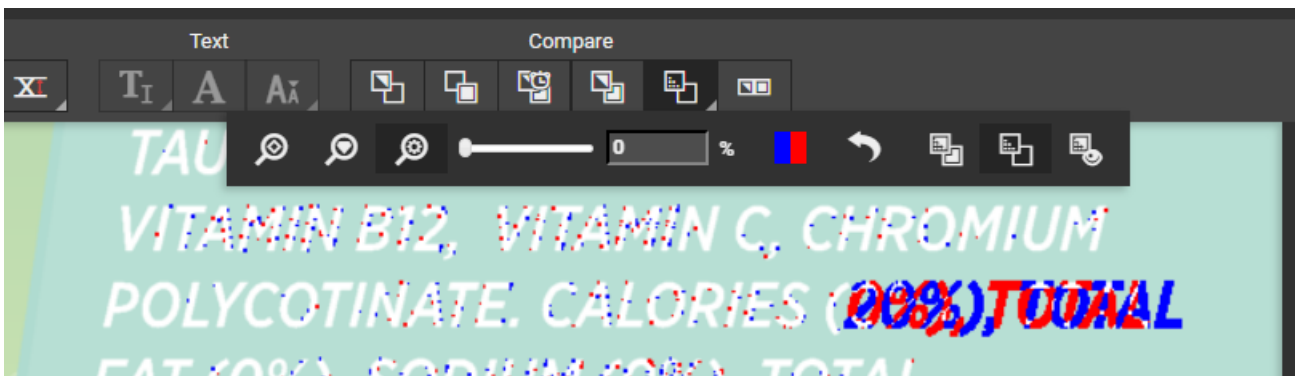

## Document Select widget and tools

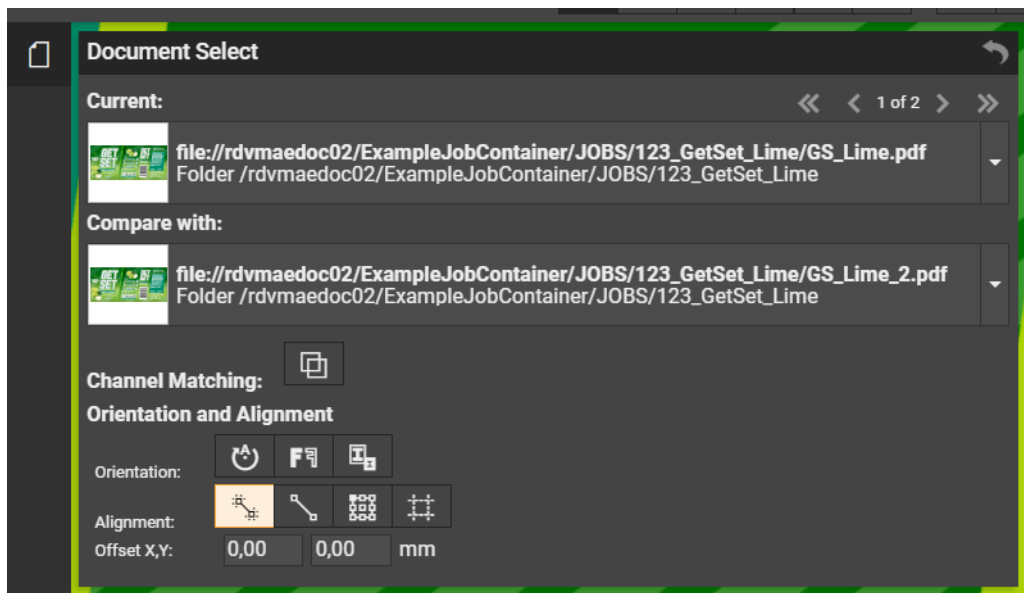

When comparing files, also the **Document Select** tool appears (by default in the left side bar ; as mentioned [earlier](#), you can move it).

Click  to open or close the Document Select widget.



### The Documents you Selected to Compare

The widget shows the URL of both documents. You can stretch the widget horizontally to make it fully show a longer URL.

- In **Current**, click  to the right to switch this document to another one in the list of loaded documents. This feature is not available in this Viewer but it can be used to select a different page in that same document.
- In **Compare with**, click  to the right to **Turn off comparison** mode. This will close this reference document but the Viewer will remain in comparison mode. When you turned this off, you will see a **Click to select a Document (page)** and the only one in the list will be the one you just closed.

These tools are more useful when you are comparing multi-page documents. Learn more in [Working with Multi-Page Files](#) on page 1143.

## Matching Channels

### Concept

Sometimes you may want to compare channels that do not have a same channel definition. For example:

- A channel that is actually the same but has a different display color in the 2 compared files. For example an ink 'Cut' that was defined to look green in one file and pink in the other.
- Channels that are related but have different ink names in the 2 files. For example '123' and 'Pantone 123 C'.



The **Channel Matching** tool allows you to make manual matches or define automatic matching rules.

### The Channel Matching tool

The dialog of this tool opens automatically when you selected 2 documents to compare that do not have a same set of channels.

Alternatively, at any time during comparing, you can also open this tool from the extra  icon that will appear in the Channels widget or in the Document Select widget.

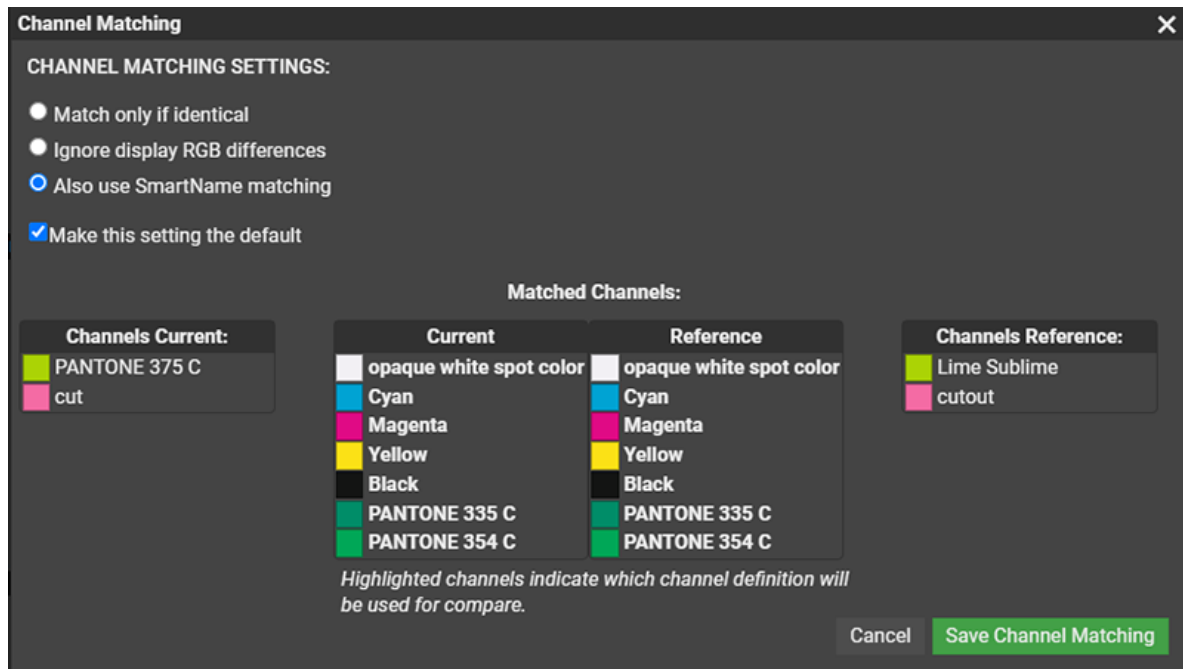

An overview of this dialog:

- **Top left, in Channel Matching Settings**, the different ways to have this matching done automatically. Learn more below.
- In the **middle**, the **Matched Channels** table shows which channels have been matched for the comparison. The way this matching was done is defined by the above selected setting. Learn more below.
- **To the left and right of that** the tool shows which channels of the **Current** and of the **Reference** are not matched yet. An automatic or a manual matching may change that. Learn more below.
- You can always **Cancel** this proposal, or click **Save Channel Matching** to agree with it and close this dialog.

### Automatic Channel Matching Rules

Choose which rule this automatic matching should follow:

- **Match only if identical:** Only channels that have an identical name and display color are matched automatically.
- **Ignore display RGB differences:** Channels are automatically matched when their name matches. Differences in display colors are ignored.
- **Also use smart name matching:** In addition to ignoring display color differences, this setting also matches channels that have a different ruling, angle or dot shape or have related names. Some examples:



- Inks with names that only differ in use of upper and lower case. For example: 'Kiwi Green' will match to 'Kiwi green'.
- Inks with names that only differ in color book specification. For example: '660' will match to 'Pantone 660 C' and 'Cyan' will match to 'Process Cyan'.
- Inks with names that are known abbreviations of each other. For example 'C' and 'Cyan'.

The effect of the chosen rule is immediately shown below in the columns and table.

Select **Make this setting the default** when you not only want to apply this rule to the current set of documents being compared, but during every comparison (without need to open this dialog).

### Manually Matching Channels

When the automatic matching does not yet match all the channels that you want to compare directly, you can also manually match channels.

To do this,

1. Select the channel from the left side list of **Channels Current** and drag it to the 'current' column in the middle table of **Matched Channels** (It will automatically be placed at the bottom of the list).
2. Then select the wanted channel from the right side list of **Channels Reference** and drag it to the 'reference' column in the middle, on the same row, across from the one you want to match it with.
3. Click on the Channel from which the definition has to be copied. The clicked channel will be highlighted in the dialog (dark black). This indicates that that definition will be used in the comparison ; that the corresponding channel copies the definition of the highlighted one.

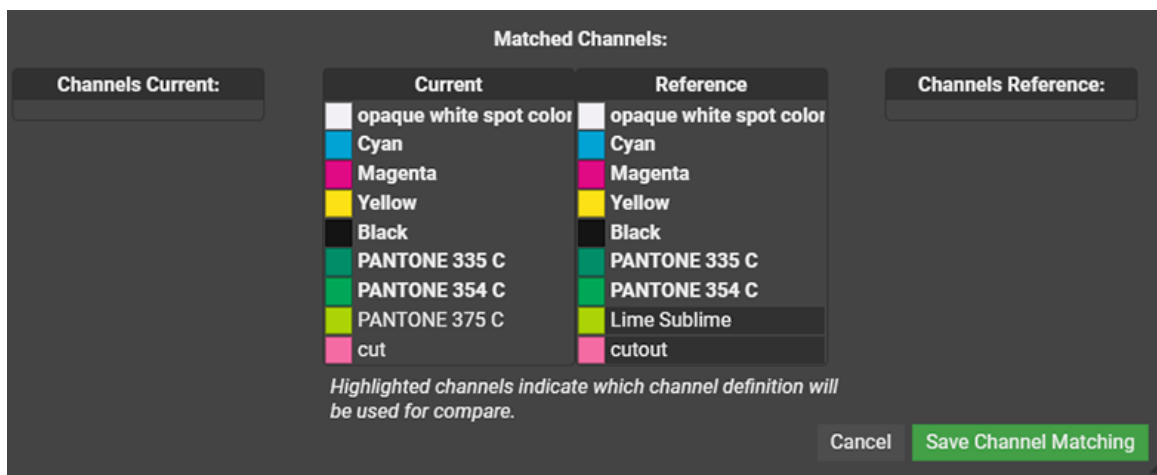

**Note:** Channel names are shown in bold when you can not un-match them.

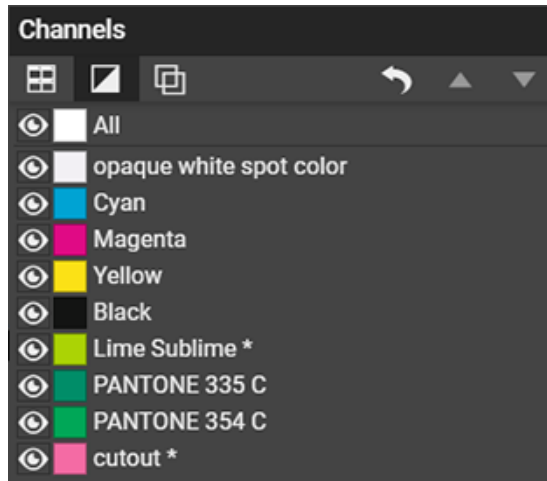

4. Click **Save Channel Matching**. After saving, in the Channels widget, the modified channel is marked with an asterisk \* next to its name.



**Note:** Instead of using **Cancel**, note that it is possible to drag a channel **back** from the middle to its left or right column (drop it high enough, right below the name of the column).

### Orientation while Comparing

Use the **Orientation** tools to rotate, mirror or invert the reference document relatively to the current document.

- : To **Rotate** the reference document.
- : To **Mirror** the reference document.
- : To **Invert** the reference document. This can be useful when comparing a positive and negative version of the same document.

### Alignment Tools

Alignment tools help you compare files with different sizes, or files with the same size where the content is offset differently from the trim box.



Apart from the ones already mentioned in [Orientation while Comparing](#) on page 1124, you can align such files by using these tools:

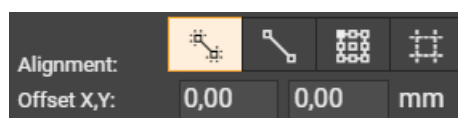

### Auto Align

 **Auto Align** uses the currently visible view of the two compared documents to attempt an automatic alignment.

When the data surrounding the alignment points match, the tool will be able to increase the alignment precision (and have a good alignment with fewer iterations).



**Note:** The resulting **offset** values are filled in automatically.

Using this tool repeatedly with one or more zoom-ins can be a very easy and fast way to align two files. Its accuracy increases when the documents have a high resolution.



**Note:** You can disable an automatic alignment by manually changing the offset values. Alternatively, go to the **Compare with**, click  to the right and click **Turn off comparison**.





**Note:** You can also use this to align the CAD overlay on the graphics correctly.

### Manual Alignment using Anchor Points

In case you would need it, there is also a manual way to align documents, although you can still combine this method with a final touch of automatic alignment as well.

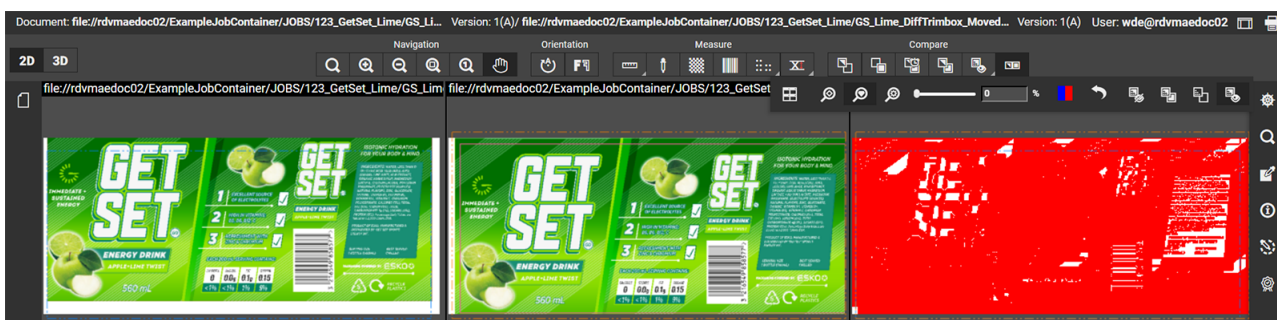
1. In the top tools bar, select your preferred compare view mode. In the example we use on this page, we chose  **View both - Side by Side**. See how the difference view on the right shows up very red, as expected because the documents are not aligned at all:



2. In the Document Select widget, click  the **Anchor Point Alignment** tool.  
The Viewer now replaces the default top tools bar by a new 'Anchor Point Alignment' tool bar.



- On top, this tool bar still offers the **Navigation** and **Orientation** tools. These will help you to work very precise.
- Below that, it offers both the manual and automatic align tools.

The 3rd view on the right is the **Alignment Result**, an overlay of both documents.

3. Now click  to activate the **Anchor Tool**, so you can start setting your anchor points manually.

Below screenshot was taken we after we already used the zoom-in and pan tools (learn the shortcuts!) to zoom in to an area that allows to define anchor points in detail (the top right corner of the barcode rectangle).

The **Alignment Result** (right side window) clearly shows that these documents are not aligned.

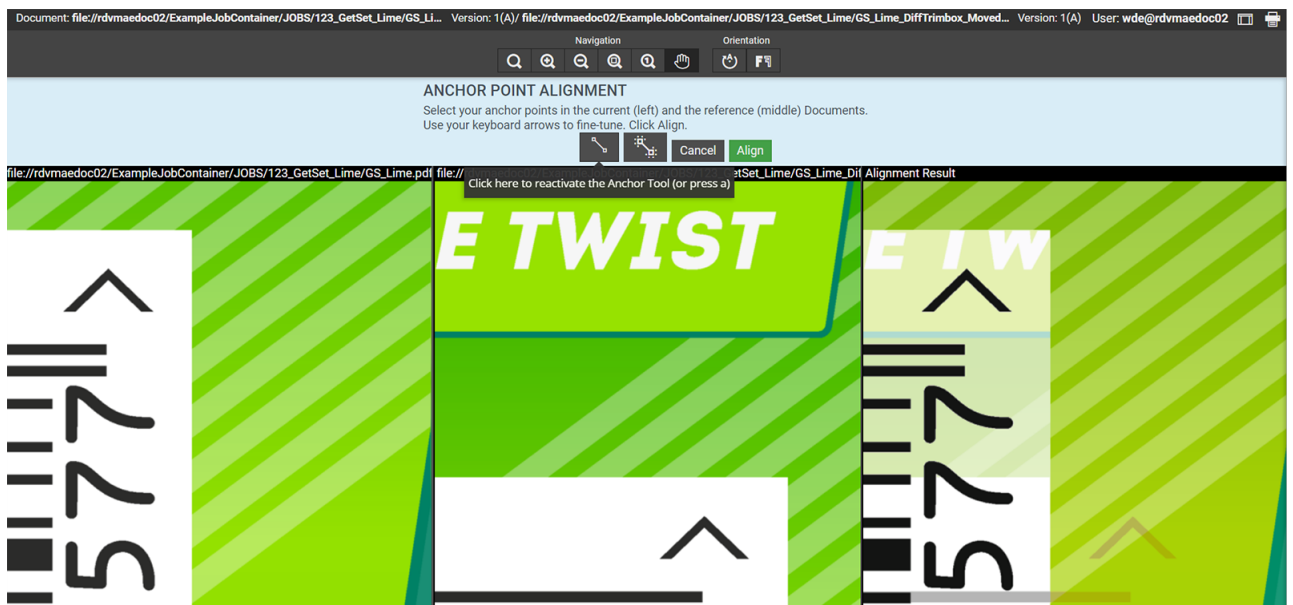

4. Now click a **first anchor point** in the left window (current).

An anchor point looks like this:



Extra tools that can help precision:

- Use your arrow keys to fine-tune the position of an active anchor point.

- You can also drag an anchor point to another location.
  - You can still zoom in to position the anchor even more precise.
5. Now click the **second anchor point** in the middle window (reference).

The reference document will instantly be re-aligned.

6. Check the result in the right **Alignment Result** window. Click **Align** to confirm this result.

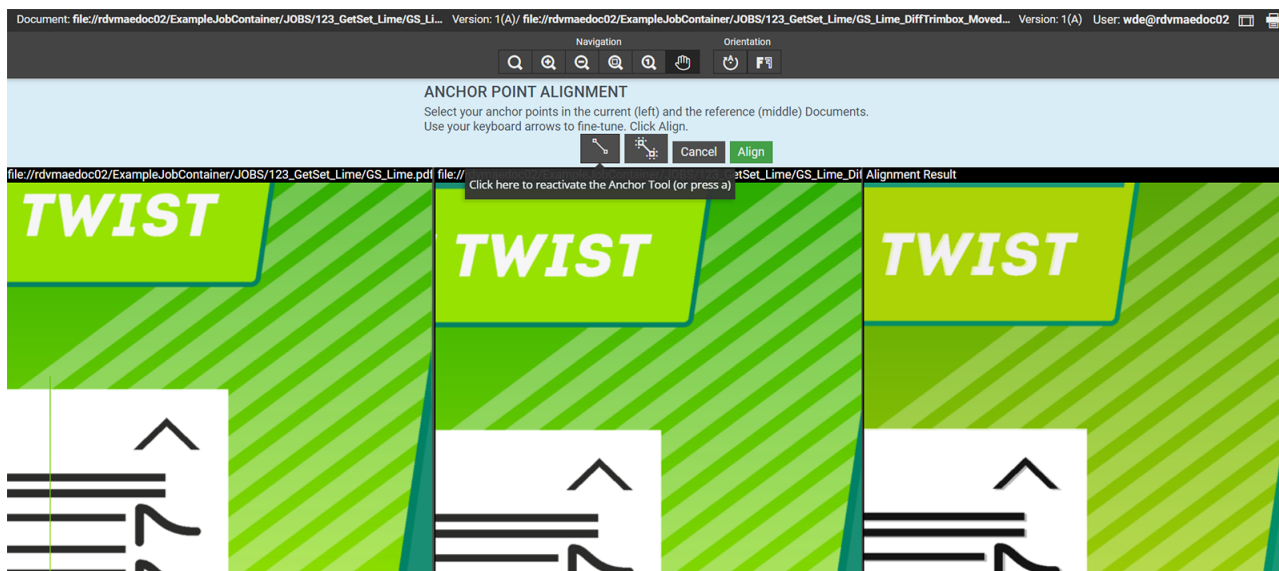

**Tip:** Even after defining the two anchor points and the alignment that was based on that, you can still click  **Auto Align**.

The Viewer will return to its original state when you click **Align** or **Cancel**.

7. Back in the initial compare view mode, the actual alignment that was done is visible in the offset fields in the Document Select widget.

The right window shows the differences based on this new alignment. In our example, there are none (the red dust particles you see in this screenshot will disappear when zooming in).

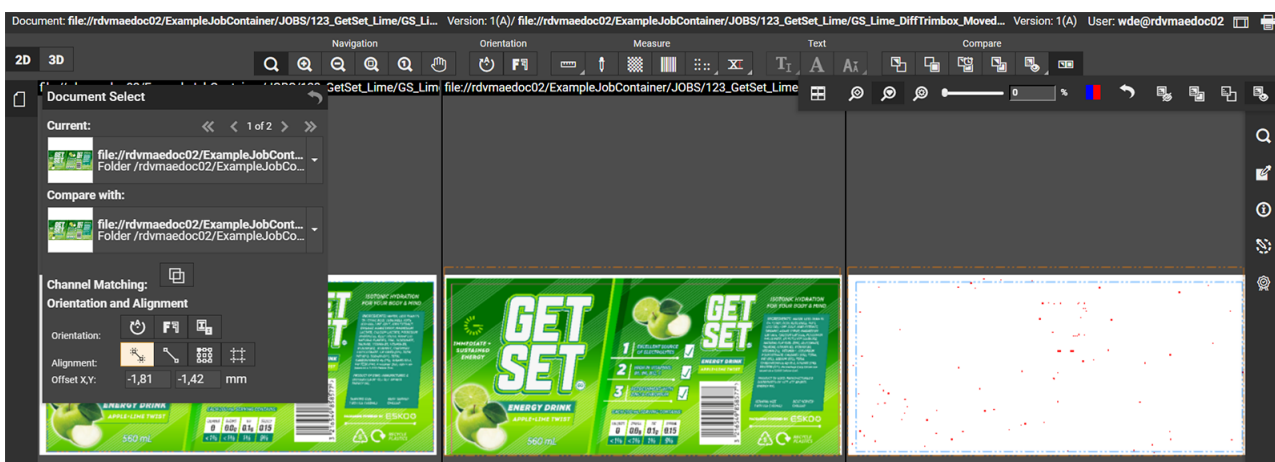

**Using Corner, Trim Box or Offset**

- Click  to define a corner that should be used to align the reference file.

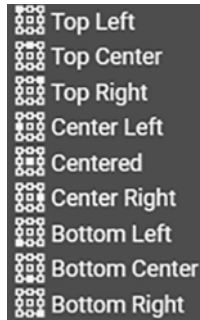

- Click  to **Use margins (trim boxes) for alignment.**

When you change the corner alignment while this is selected, the trim box alignment will be remembered.

When this is not selected or when a trim box is not described in the document's XMP, the alignment will be relative to the document's boundaries.

- You can also manually specify an **Offset.**

This offset takes the selected corner and trim box settings into account.

These fields will also show the results of any automatic or anchor point alignment.



**Note:**

- When aligning **two graphic files**, the offset will be the distance between the **current** and the **reference** according to the graphics coordinate system: the positive horizontal is set to the right and positive vertical is pointing downwards.
- When aligning **a CAD and a graphic** file, the offset is taken as the distance between the CAD overlay and the graphics page using the CAD coordinate system: positive vertical pointing downwards.
- When aligning **two CAD files**, the offset is the distance between the **reference** and the **current** document page (in that order) according to the CAD coordinate system.

**Aligning two CAD files**

Also when comparing two CAD files, you can use these alignment tools:

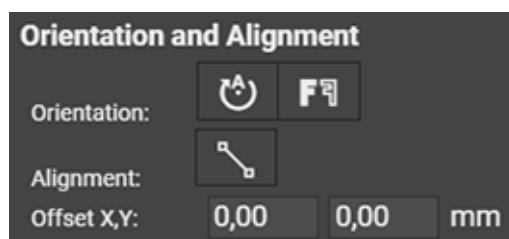

- **Rotate** the reference document.
- **Mirror** will flip your reference document (from the centre of the view).
- **Anchor Point Alignment**. Learn how to use this tool in [here](#).
- **Offset** to manually define the offset of the reference document.



**Note:** When aligning two CAD files, the offset is the distance between the **reference** and the **current** document page (in that order) according to the CAD coordinate system: positive vertical pointing downwards.

## 15.2.14. Working with Prepared View Data

### Workflow

This topic was introduced in [About Working with Prepared View Data](#) on page 1082.

We there described how this preparation is always needed for RIP'ed data and how for graphic files this concept is only available in older viewing technologies.

In those older technologies, when you regularly experience significant delays when opening files, then consider preparing view data first. Files with prepared view data always open fast. Zooming and panning will be faster on files with prepared view data. The load on the server is also smaller when using prepared view data. However, the server did have to spend a certain amount of load earlier, to prepare.



**Note:** When a (deep) zoom needs a resolution that is higher than the prepared one, the data for that zoom area will automatically be streamed from the server. You may notice this delay (visible in the progress bar).



**Tip:** In the Pilot Java based Viewer, **Ctrl-Shift-V** displays the current view resolution.

### Workflow

The [Prepare For Viewer task](#) creates prepared view data. Depending on your workflow, the size of the files and how consistent viewing delays are, you can choose to launch this task in one or more of these ways:

- **Ad hoc (manually)**, by selecting a file and launching the [Prepare For Viewer task](#) (or, in a browser client, a launching a workflow containing that task). When you often use this, consider making it a favorite ticket.
- **Automatic, as part of workflow tickets**. For example, when you often check RIP'ed data in the Viewer, then consider adding the [Prepare For Viewer task](#) as a workflow step after the RIP'ing step. Some users also add a [Wait for Action \(Checkpoint\) task](#) to create a QC step in the users' To-Do list. An example:

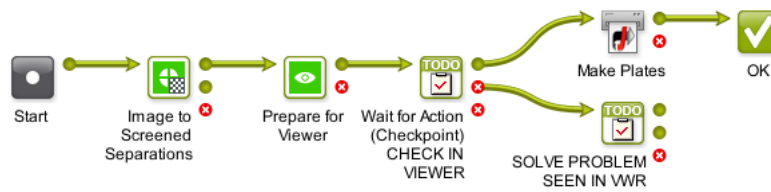

- **Automatic, for all files in a specific folder.** For example, when you check all files arriving in a specific folder, you can have that folder automatically launch the *Prepare For Viewer* task on all incoming files. This way, you win time when opening those files in the viewer. Learn more in [Speed Up For Viewing](#) on page 1131.

### Make sure your Prepared View Data is Up-To-Date

As mentioned in [Starting the Viewer from the Pilot](#), you will not be able to view a file when it has prepared view data that is outdated (older than the source file). In a Pilot, this is indicated by a specific status in the **View** column: - (Prepared).

View data typically becomes outdated because the source file has a more recent modification date. So make sure you only create the prepared view data as a last step before checking it in the viewer.



**Important:** View data that were created with another viewing technology than the *current one configured for that type of files* will need to be created again.



**Attention:** Prepared view data becomes useless when the source file was manually moved or renamed (manually = without Automation Engine knowing about this).



**Note:** When you move a source file with the *Copy or Move File task* or using the features in the browser client, then the view data will follow automatically.

Learn more in [Managing View Data](#) on page 1132.

## Prepare for Viewer Task

### Concept

This task creates view data that will be used when you open its input file(s) in the Automation Engine Viewer. The supported files types for this task are those that the Viewer supports, combined with which viewing technology is used. Learn all about both in [Several Viewing Technologies](#) on page 1080.



**Restriction:** When, in the *Configure tool*, you choose to open PDF files using the latest technology as also used in ArtPro+, creating prepared view data is no longer possible ; this task will fail then. Note that with that configuration, this task remains possible for RIP'ed data.



**Attention:** In many cases, you do not have to use this task before opening a file in the Viewer. Learn more about this choice and workflows using prepared view data [here](#). Find an introduction to the Automation Engine Viewer [here](#).

### Task Settings



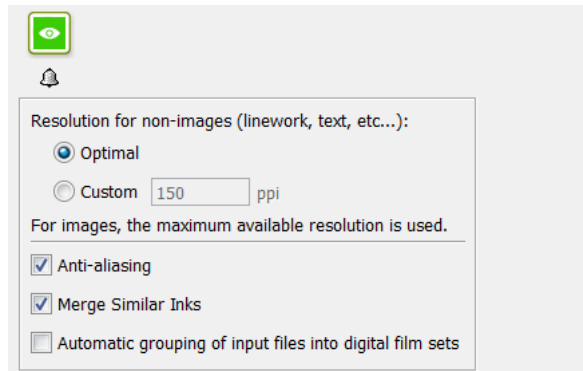

• **Resolution for non-images:**

- **Optimal:** The task uses a smart algorithm to decide the optimal resolution for the view data (the one that offers the best balance insuring both speed and detail). The calculated resolution is mentioned in the tasks 'Details' pane and in the log file.
- **Custom:** Specify the resolution yourself.



**Attention:** We advise to only set a custom resolution in cases where you found that the optimal setting created a too small or too large set of view data.

- **Anti-aliasing:** This smooth-ens the staircase effect when images are generated from line-art objects.
- **Merge Similar Inks:** This merges inks that have a same name but have a different ruling or angle.



**Attention:** We strongly advise to enable this option when viewing ArtPro files or Normalized PDF files generated by ArtPro.

- **Automatic grouping of input files into digital film sets:** When digital film separations (RIP'ed files) are grouped into sets, they will open together in the Viewer and can so be inspected as a composite image. See some examples in [Working with RIP data](#) on page 1133.
- When this option is **not selected**, the list of task input files that the user manually selected or that a workflow created for this ticket will be **grouped regardless of their file names**. This is how you can for example get a composite view of these files (where not all have the same name before the suffix with the ink name):

Name ▲	View	Type	Size	Date
GreenMan_K.len	<a href="#">View</a> (Prepared)	CDI File	6.6MB	9/2/15 4:10 PM
Shrek_C.len	<a href="#">View</a> (Prepared)	CDI File	13MB	9/2/15 4:10 PM
Shrek_M.len	<a href="#">View</a> (Prepared)	CDI File	12MB	9/2/15 4:10 PM
Shrek_Y.len	<a href="#">View</a> (Prepared)	CDI File	5.7MB	9/2/15 4:10 PM

- When this option is **selected**, the grouping is done automatically **based on the file names** of the task input files. Using above example, you would then get 2 groups for composite viewing: one with only 3 separations from the `Shrek` files and one with one separation from the `GreenMan` file.

### Speed Up For Viewing

As mentioned [above](#), you can have prepared view data created automatically for all **new** files in a subfolder of a [Job Folder](#).



**Attention:** Using this option will generate view data as soon as a file is written in this folder. And when a file in this folder is updated, its view data will be regenerated. This can lead to overhead on the server when view data are generated that will not be used. Therefore, as a more optimal alternative, consider inserting a **Prepare for Viewer** task at the right place in your workflows.



**Restriction:** This functionality was more important when *older viewing technologies* would be able to also *prepare graphics data for viewing*. This tool is not advised to be used for RIP'ed data.

The following setup is **only possible in the Pilot**, not in a browser client:

- To add this functionality to a folder, right-click any folder in a Job folder and select **Speed Up for Viewing**. The folder will get a specific icon . From that moment on, Automation Engine will automatically launch the **Prepare for Viewer** task on all new or modified files (that the **Speed Up for Viewing** task supports as input files).

The ticket of the **Prepare for Viewer** task that is used for these automatically launched tasks is defined in [the Configure tool](#).



**Tip:** When you are *creating Jobs* based on a template Job that has a subfolder with the attribute "**Speed Up for Viewing**", then this attribute will be inherited in the folder in the new Job.



**Note:** When, in such a folder, a file is opened and being edited in classic editors PackEdge or Plato, the system will not re-created this view data every time you click **Save**. The **Prepare for Viewer** task will only start and update the view data once the file is closed in the editor.

- To stop this functionality, right-click the folder and select **Speed Up for Viewing** to switch it off again. This attribute is also removed automatically when the Job is removed, exported or archived.

## Managing View Data

The [Prepare for Viewer Task](#) creates the prepared view data in a hidden `.view` folder next to the input file.



**Warning:** Accessing that hidden folder and deleting, moving or renaming this view data manually will create Viewer errors.

The size of the view data depends on the chosen resolution and on the size and amount of channels of the source file.

Because this data is not small and temporary by nature, these mechanisms help to clean up the prepared view data:

- When you *demote a Job* (by removing, exporting or archiving it), all view data in that job folder is **automatically** deleted.
- In the Pilot, you can **manually** delete the (hidden) prepared view data, by:
  - right-clicking a file and choosing **Delete View Data**. This removes the prepared view data for that selected file only.
  - right-clicking a folder and choosing **Delete View Data**. This removes the prepared view data for all files in that folder and its subfolders.

## 15.2.15. Working with RIP data

### A Composite View of RIP'ed Separations



**Note:** As mentioned in [the introduction](#), RIP'ed files (aka 'digital film sets') require prepared view data before you can open them in any Automation Engine Viewer.

When you want to see a composite view of all RIP'ed separations of a file, you do not need to multi-select these files and click 'View' (icon). You only need to select one of them and click 'View'. The viewer will automatically load the other separations.

This mechanism does require that the [Prepare for Viewer task](#) was launched on all files together and that the option '**Automatic grouping of input files into digital film sets**' was enabled.

### Measuring Screen Ruling and Angle

When viewing RIP data, you can use : the **Calculate Screening and Angle** tool.

Similar to the [densitometer](#), you can click a point or click-drag an area to be measured, or you can double-click to make a measurement based on the current selection or, when no selection is active, the current view.

The results show up in a pop-up and in the [Channels panel](#). Click or use **Ctrl-Shift-U** to choose the measurement units.

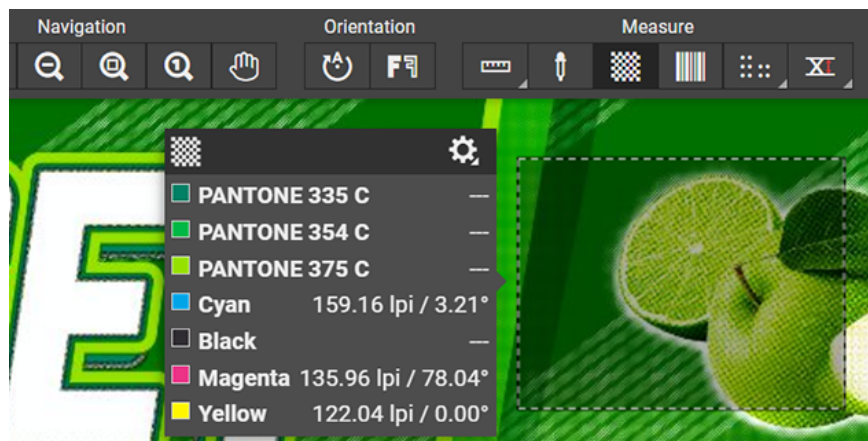

**Important:** When no screen ruling or angle can be measured, no values are shown for that channel. This can be because there's no such data in that area or because there's only 100% of such data in that area.

### Changing the Orientation of the Screen Angle

In the pop-up, click  and, at the bottom, select the way measured screen angles should be shown: **Screen Orientation CW** (clockwise, downwards counting) or **Screen Orientation CCW** (counter-clockwise, upwards counting).

**Checking Registration Errors while Viewing Dots**

The *registration error* tool is also available when viewing RIP'ed data.

Here is an example where a white gap appears on a file that was trapped with 0.2 mm, while simulating a max error of 0.3 mm:



**Extra Set of View Data for Print Simulation**

When using advanced screening effects, it is possible that the dot on screen does not look like the dot when printed.

Esko RIPs allow creating an extra set of view data that simulate the printed dots. This is an extra option in the tab 'Output' of an Imaging Engine task ticket.

An example: On the left we see a Concentric screen at 27% (with its typical ring-shaped holes). On the right we see its print simulation, where the holes were filled with ink:



Learn more about creating print simulation view data in the chapter on [Imaging Engine](#), in [Inspecting Screens with Advanced Screening Effects](#) on page 1214.

### 15.2.16. Working with 3D

The left side of the top tools bar shows the **2D** **3D** buttons (except when viewing RIP'ed data). You can activate one of them or both. The 3D view can also show transparency, reflection, etc.

- Click and drag the mouse to rotate and swirl. Scroll to zoom in or zoom out.
- Use **Shift + drag** to change the object's position.
- Use **CTRL + drag** to change the lighting angle.

The 3D view supports various modes:

- You can view graphic files together with their 3D version.
- You can simulate a visualisation of the printed finishing of a graphic file.
- You can view 3D files themselves.

Some examples:

- **Viewing a PDF that links to a ZAE or DAE file.**

See an example of a PDF that has a valid link to a ZAE or DAE (Collada) file.

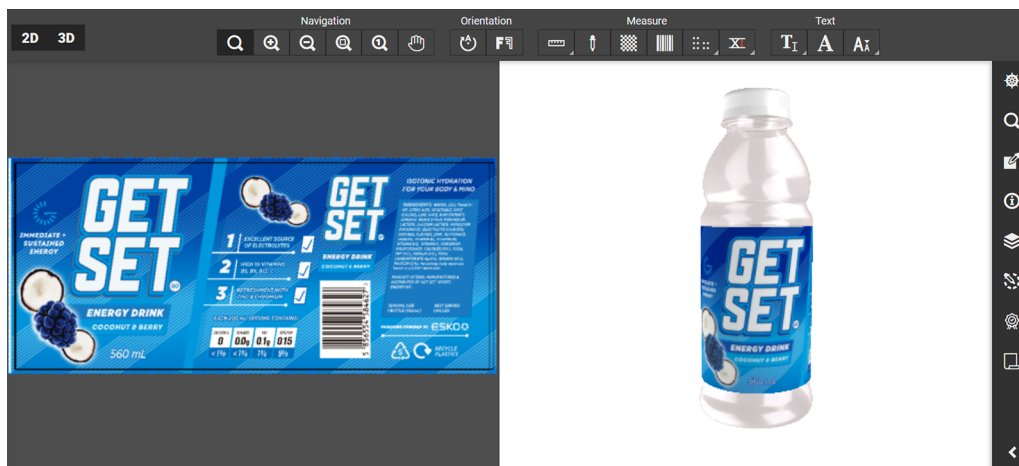

**Important:** The link to the structural file must be the name of the structural file only. Absolute or relative file paths are not supported.

- **Viewing a PDF that links to an ARD file.**

See an example of a PDF that has a valid link to an ARD (ArtiosCAD) structural design file.

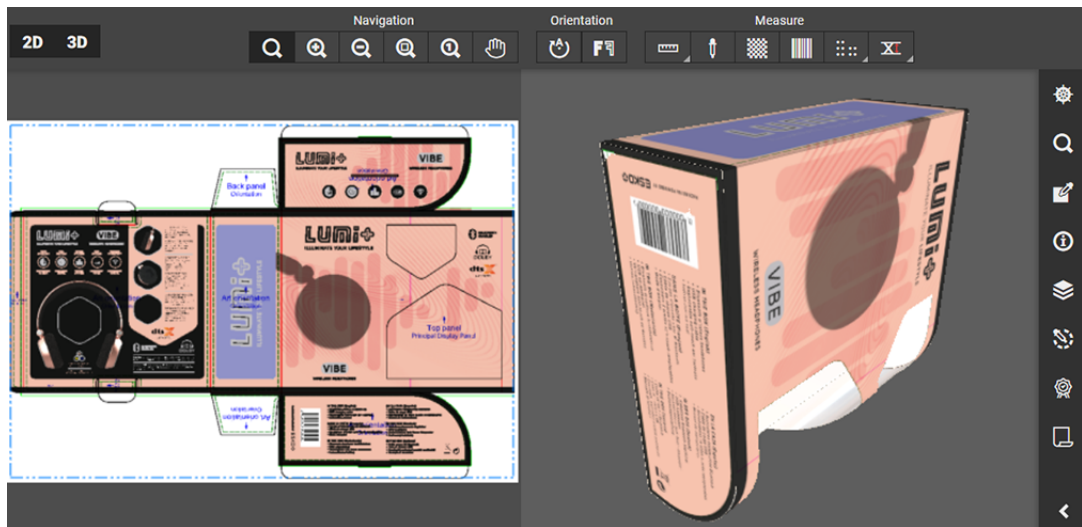

**Important:** The link to the structural file must be the name of the structural file only. Absolute or relative file paths are not supported.

- **Viewing an ARD file.**

Opening an ARD file itself in this Viewer will, when the required structural is available, also show its 3D version:

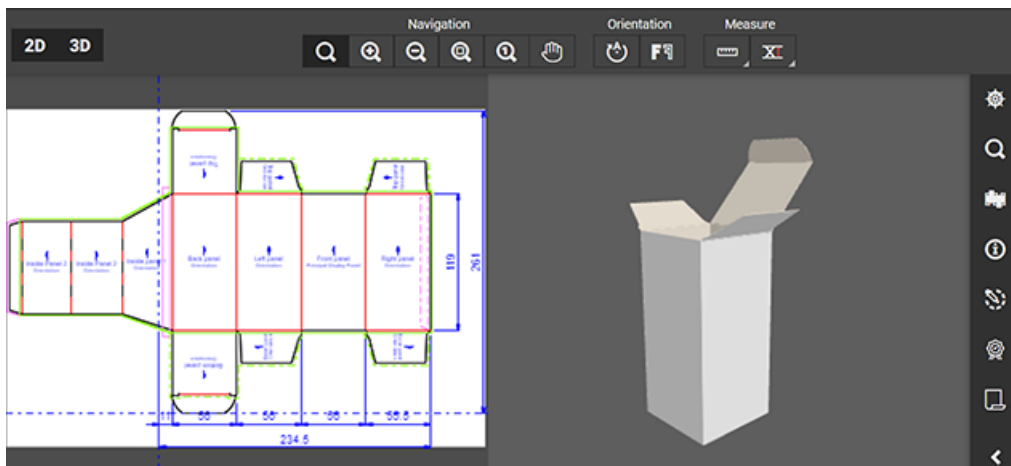

- **Viewing a ZAE or DAE file.**

Opening a Collada file itself in this Viewer will also shows its 3D view.

See first a collada file with the graphics info embedded and then one without any graphics info:

Document: file:///rdvmaedoc02/ExampleJobContainer/JOBS/123\_GetSet\_Lime/3D/GET SET\_BOTTLE\_GREEN.zae Version: 1(A) User: wde@rdvmaedoc02



Document: file:///rdvmaedoc02/ExampleJobContainer/JOBS/123\_GetSet\_Lime/3D/blue/GET SET\_BOTTLE\_OUTlines.zae Version: 1(A) User: wde@rdvmaedoc02



- **Viewing a print finishing simulation of a PDF.**

When you open a graphic file that does not have a link to valid 3D data, you can still request a 3D view but it will show a flat representation. An example:



However, you can still define several 3D options to display a print finishing visualisation. An example:

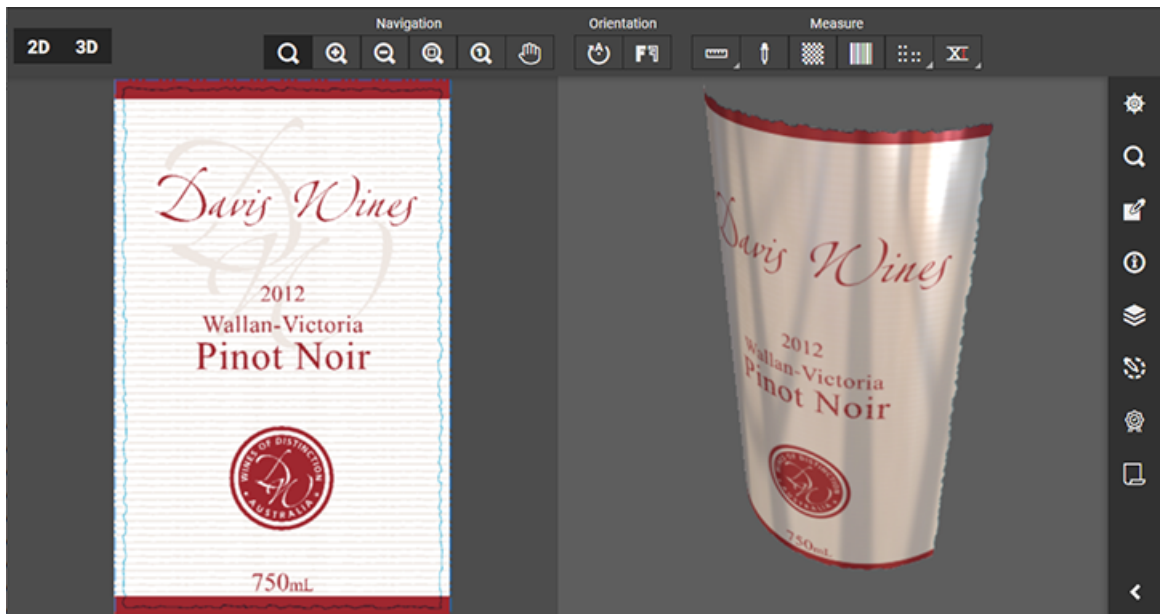

Learn more in [3D Setup](#) on page 1138.

### 3D Setup

With the 3D view mode activated, click  in the right side tool bar to open the **3D Setup** widget. It offers a few parameters to create a finishing visualisation of the printed PDF.

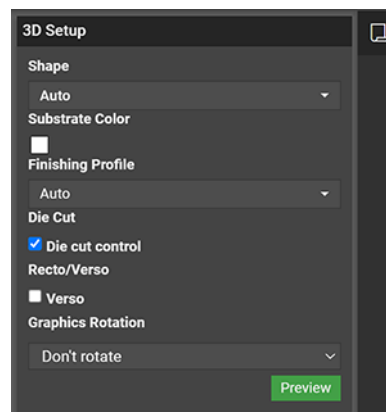

This widget will be empty when the opened PDF already links to a 3D file (ZAE, ARD) which already includes most of these parameters.

- **Shape:** Select **Auto**, **Flat sheet** or **Curved Sheet** (which will ask to specify the **Angle** of the curvature in degrees).
- **Substrate Color:** Pick the color that the substrate should be simulated with.
- **Finishing Profile:** This Viewer can visualize 3D simulations of specific finishing effects, such as varnish or embossing. A finishing profile defines how the separations of a given PDF are mapped to these effects. You can here choose from nine profiles that each map to a set of characteristics of that print substrate and finishing steps.



- **Die Cut Control:** Choose to show the die cut lines in this 3D view.
- **Recto/Verso:** Choose this option to view the text written or printed on the front side and on the back side.
- **Graphics Rotation:** Choose a rotation angle that you wish to see in the 3D view.

Click **Preview** to apply and view the settings instantly in the 3D view.





### 15.2.17. Working with Annotations

All annotations in this Viewer are read-only.

The Viewer can show 2 types of annotations:

- Approval workflow annotations. These are only available when using the Viewer's [latest technology](#).
- Inspection workflow annotations.

Click  to open the annotations widget. It offers these tools:

- : This icon is not used - annotations remain read-only.
- : Step through the annotations, including zoom-in.
- : Refresh, to pick up new or changes in annotations.
- : Settings regarding display, filtering, order.

#### Share & Approve Approval Annotations

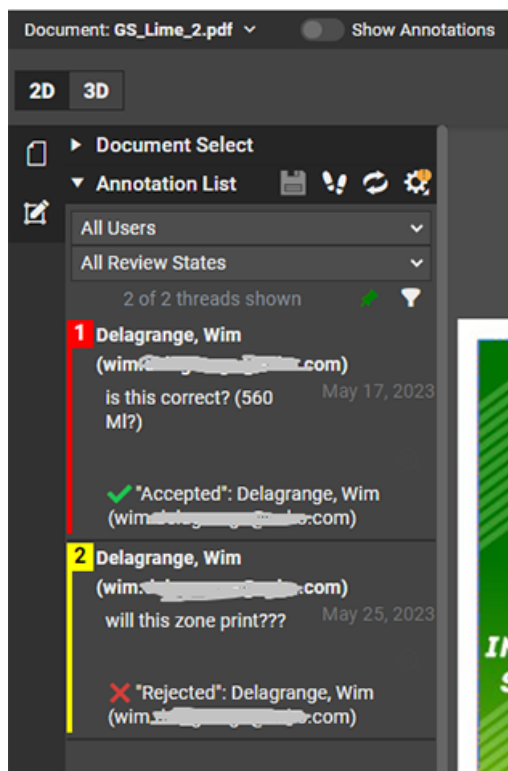

The Viewer (and ArtPro+) will only be able to show the S&A annotations when the file includes a metadata link describing its place on Esko Cloud. Learn about this required link in [Task 'Upload Files to Share & Approve'](#) on page 1762.

Learn all about Share & Approve annotations

- in the [user guide of the Share & Approve Viewer](#).
- by watching the eLearning video on the Esko Blended Learning platform <https://learning.esko.com/course/view.php?id=61>.

### GlobalVision Inspection task annotations



**Note:** Learn more about the GlobalVision Inspection tasks and the XFDF files they create in [GlobalVision Inspection Tasks](#) on page 1155.

When viewing an inspected file in the Automation Engine Viewer, the annotations that these tasks may have created will be automatically visualized in the Viewer.

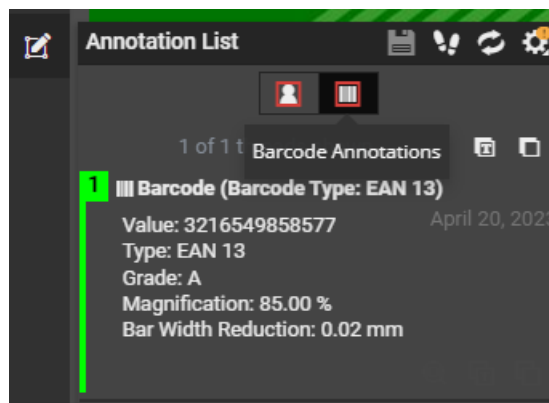

Learn more below in [Viewing Inspection task Annotations](#) on page 1140.

### Viewing Inspection task Annotations



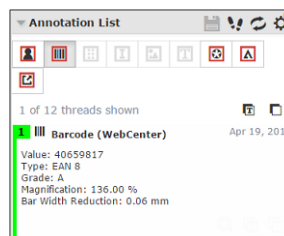

When a document has XFDF type annotations, a group of buttons is shown in the Viewer's **Annotation List**. Select any of them to see their details.



Click the **User Annotations** button to view or hide those of specific users.

The GlobalVision Inspection tasks can create these five different types of annotations:

- **Barcode Annotations**

-  **Braille Annotations**
-  **Spell Check Annotations**
-  **Artwork Compare Annotations**
-  **Text Compare Annotations.**



**Note:** Also these types of annotations are read-only. You cannot reply to them.

Some examples:

- You can view the **Braille**, **Barcode** and **Spelling** annotations on a single document.



- **Artwork Compare** and **Text Compare** annotations are available when you used the functionality in the [Inspect Artwork task](#).

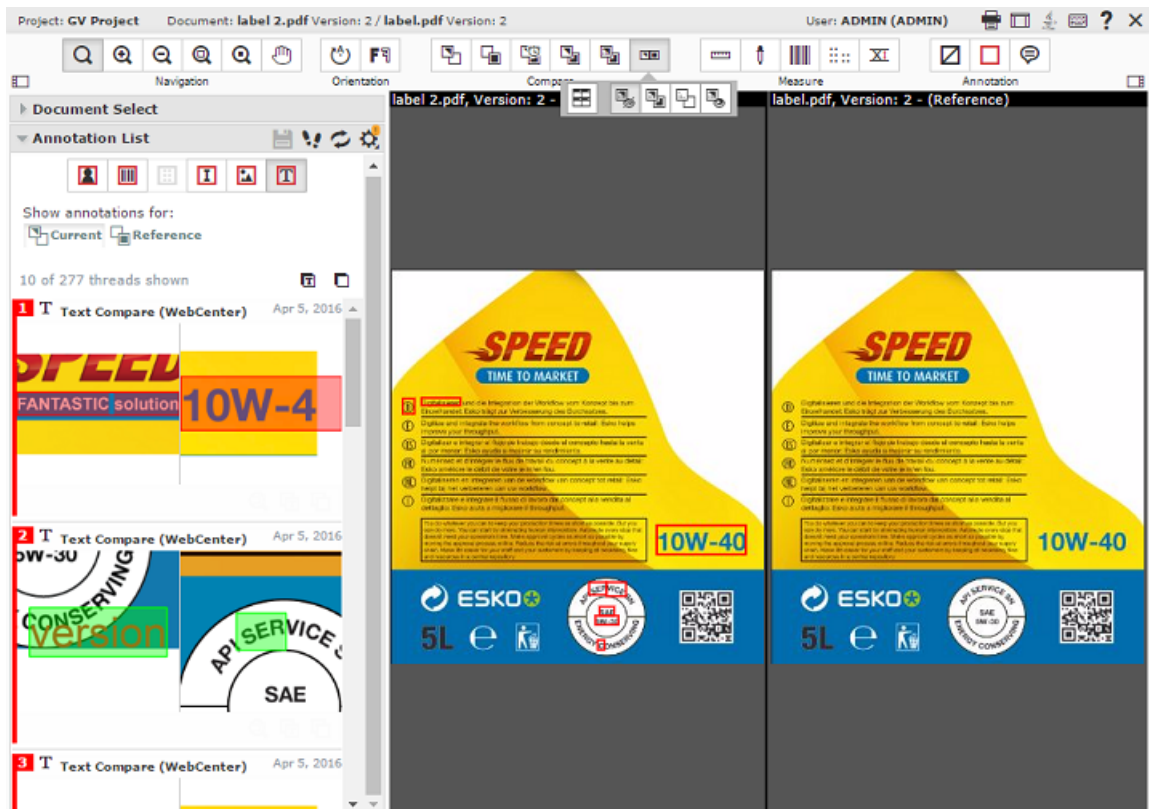

**Based on XFDF**

The five *"Inspection" tasks* generate XFDF files that contain inspection annotations. These XFDF files are written in a hidden subfolder.

When viewing a file in the Automation Engine Viewer that has such XFDF data, they will appear in the **Annotation list**.

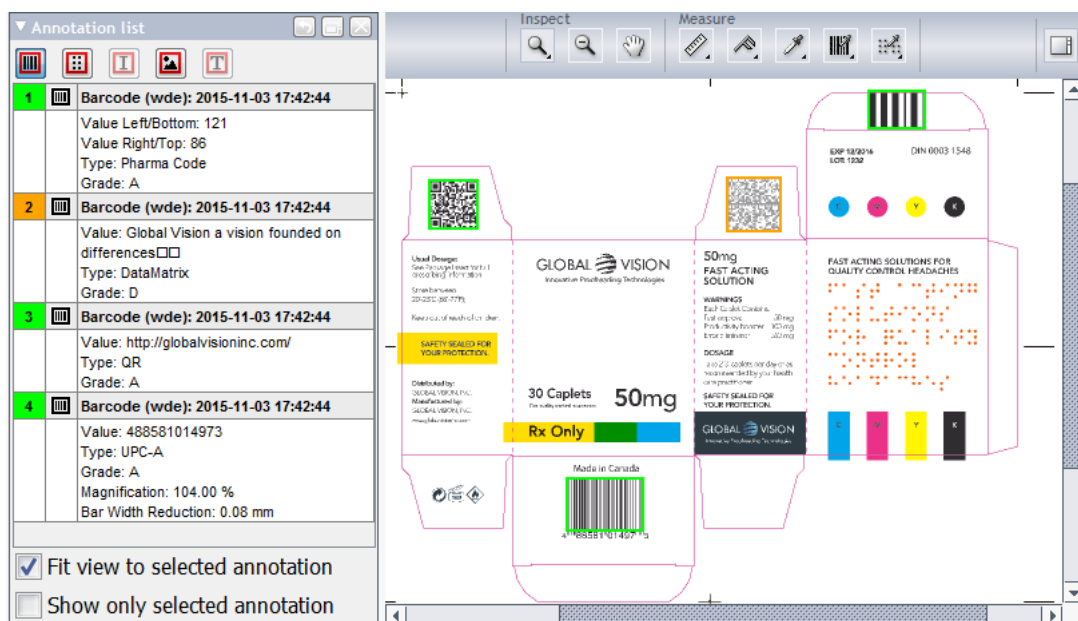

### The Inspection Annotations List Panel

- Click its toolbar icons to choose the type of annotations that you want to see detailed. Tool-tips mention their type. They are greyed out when no such annotations are available.
- Each annotation is assigned a specific number and color.
- Select an annotation in the panel to see its colored rectangle highlighted in the main window. When **Fit view to selected annotation** is selected, the window will also zoom in to that object or found difference.
- For multi-page files, the panel shows the annotations of all pages.
- Annotations can show as outdated when the modification date of the viewed file is newer than the date when the inspection task was run on that file (modification dates of any referenced files from the input file are not taken into account).

Learn more about the content of the annotations in the pages on their respective task: [Inspect Barcodes](#), [Inspect Braille](#), [Inspect Spelling](#), [Inspect Artwork](#), [Inspect Text](#).





**Attention:** When you move or copy the input file using the [Copy or Move File task](#) or the [Publish on WebCenter task](#), the hidden folder with the XFDF file will be moved as well. However, when you move the input file with other tools, Automation Engine is not aware and the XFDF file will not move along and will so not be found from the new file location.

## 15.2.18. Working with Multi-Page Files

### Extra tools

When opening a multi-page file, extra viewing tools become available:

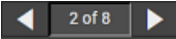
- In the top tool bar:
  - Click  to switch to a reader spread view (pairs of pages).

- Use  to navigate or select a page.
- In the left side bar, click  to open a **Page List** widget.



Although you can view two pages at the same time, there can only be one active page: the one with its number in a yellow highlight (its folio number). You can make a page active by clicking on its thumbnail.

In above example, the pairs of pages are displayed according to 'left edge binding': The first page and the odd numbered pages are displayed on the right. The even numbered pages will be on the left. Your PDF may be different and show a 'right edge binding': the first page and the odd numbered pages are then displayed on the left, and even numbered pages on the right.

### Comparing Multi-Page files

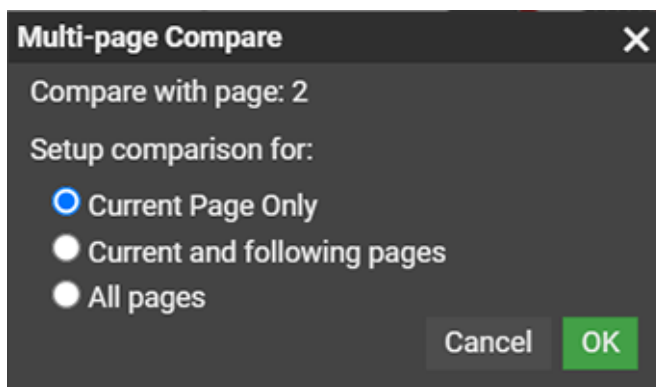

This dialog asks you to define how the pages of the active document should be mapped to the reference pages.

- **Current Page Only:** To map the current active page to the selected reference page. The other pages will follow page number mapping.
- **Current and following pages:** To map the current active page to the selected reference page. This mapping will be used for the next reference pages. If there are no following reference pages, the last one will be set as the 'Compare To' page.
- **All pages:** To map all pages of the two documents. The previous current pages will be mapped to the respective reference pages. If there are no previous reference pages, the first one will be set as the current page.

Select an option and click **OK**.

### 15.2.19. Keyboard Shortcuts (latest technology - browser)

On macOS, as a standard practice, replace below mentioned **Right-click** by **Ctrl-click** and replace **Ctrl-** by **cmd-**.

<b>Ctrl-Down Arrow</b>	Pan 1/4 window down
<b>Ctrl-Left Arrow</b>	Pan 1/4 window left
<b>Ctrl-Right Arrow</b>	Pan 1/4 window right
<b>Ctrl-Up Arrow</b>	Pan 1/4 window up
<b>End</b>	Go to last file or page
<b>Home</b>	Go to first file or page
<b>Page Down</b>	Go to next file or page
<b>Page Up</b>	Go to previous file or page
<b>Right-click</b>	Switches the zoom in tool to a zoom out tool
<b>Click or Ctrl- '+'</b>	Zoom in by a factor 2
<b>Right-click or Ctrl- '-'</b>	Zoom out by a factor 2
<b>Keep spacebar pressed in</b>	To temporarily pan. Release to go back to previous active function.

<b>Ctrl-O</b>	Fit document in view
<b>Ctrl-A</b>	Select all
<b>Ctrl-D</b>	Clear selection
<b>Ctrl-L</b>	Auto align
<b>Ctrl-M</b>	Mirror view
<b>Ctrl-S</b>	Toggle between current and previous view (in difference view mode)
<b>Ctrl-U</b>	Toggle size units
<b>Ctrl-Shift-U</b>	Toggle resolution and screen ruling units
<b>F5</b>	Zoom in
<b>F6</b>	Zoom out
<b>F9 or Double click</b> 	Fit document in view

## 15.3. PitStop Preflight

---

### 15.3.1. Preflight Concept

Preflighting can be done for several reasons:

- Just to check a file (no "fixes" done).
- To check and correct ("fix").
- To do more than just fixes, to edit a file through one or many "actions".

There also several ways to make preflighting a part of your workflow:

- You can send the design back for others to correct it.
- You can correct what was found to be wrong and continue the workflow.
- Right before sending the file to output, you can do (another) final check, now to prevent outputting wrong data.

#### Tools

Automation Engine's [PitStop Profile Editor](#) is where you can create and manage

- PitStop **Profiles**: A set of rules that a file's content should adhere to.
- PitStop **Action Lists**: A set of changes you want to execute on a file.



In Automation Engine, you can use these profiles or action lists by using the [Preflight with PitStop task](#).

### 15.3.2. The PitStop Profile Editor

You can create and manage PitStop PDF **Profiles** and **Action Lists** in Automation Engine's **PitStop Profile Editor**.

You can find an extensive documentation on PitStop on <https://www.enfocus.com/en/support/manuals/pitstop-server-manuals>.

We here limit our description to topics specific to Automation Engine:

#### Setting Up the PitStop Profile Editor

This tool is one of the client tools that you can download from the [AE Server ADMIN web page](#).

1. Open this **Server Web Page** by entering `http://<name of your server>` or `http://<name of your server>:9999` in the address field of your browser. You can find this tool in the section **Client Apps**, in the page **Tools**.
2. Click **Download** to install the **PitStop Profile Editor** on your client computer.
  - On Windows:
    1. Double-click the downloaded `Automation Engine PitStop Profile Editor.exe`.
    2. Click **Next** and click **Yes** to confirm the installation.
    3. **Browse** to the install location, by default `C:\Esko`.
    4. Click **Next** and click **Finish**.
  - On Mac:
    1. Double-click the downloaded `Automation Engine PitStop Profile Editor.dmg`.
    2. Double-click the resulting `.pkg` file.
    3. Click **Continue** and click **Change Install Location** to specify an install location.
    4. Click **Install** and fill in your credentials to confirm.
    5. When "**The installation was successful**" appears, click **Close** to finish the installation.
3. Start the application from:
  - (Windows) **All Programs > Esko > Automation Engine PitStop Profile Editor > PitStop Profile Editor**.
  - (Mac) **Applications > Automation Engine PitStop Profile Editor > PitStop Profile Editor**.
4. In **Edit > Preferences**, fill in the host name of your Automation Engine server. This is needed to make this tool see the profiles and action lists on that server.

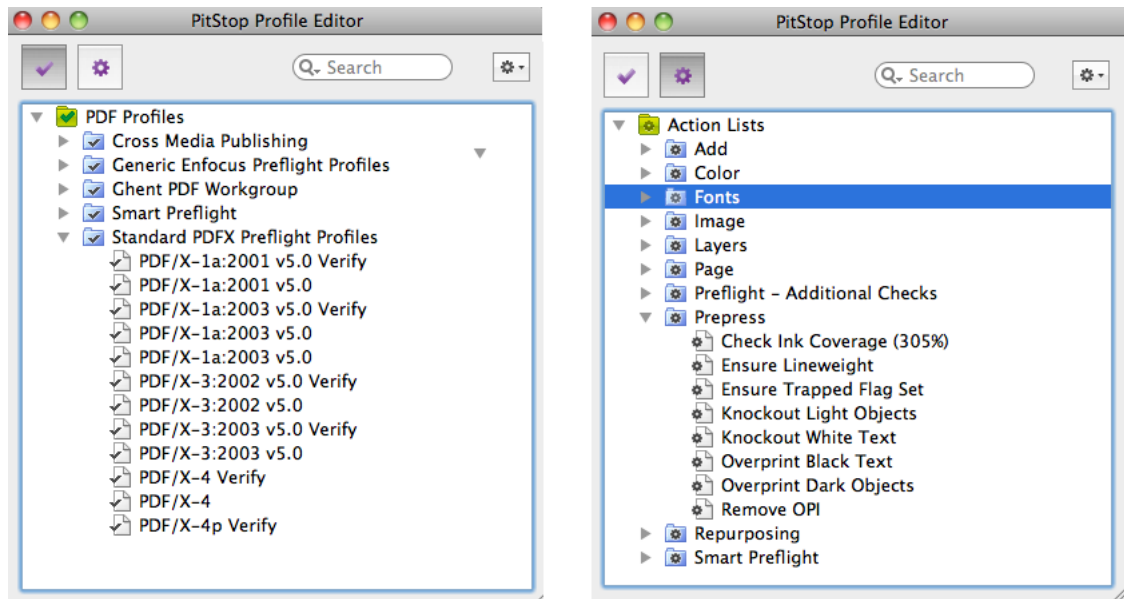

### Smart Preflight: Using Variable Names in PitStop Profiles

Just like when using task Tickets, you can reduce the number of profiles and action lists by using SmartNames. In PitStop terminology, this concept is named "**Smart Preflight**".

Follow these steps:

1. Use the Pilot to create SmartNames. Learn more in [Creating a SmartName \(General\)](#) on page 651.
2. In the **PitStop Profile Editor**, select one of the **PDF Profiles** and click on . Choose **New** and choose any of its options.
3. In the open profile, enable one of the options in the category **CHECK ON**.
  - a) Choose any of the **Available Checks**.
  - b) Click on and choose **Enable Variable Names** ('Variable Names' is PitStop's term for SmartNames).
4. Click on the blue SmartName icon to open a list with all global SmartNames.

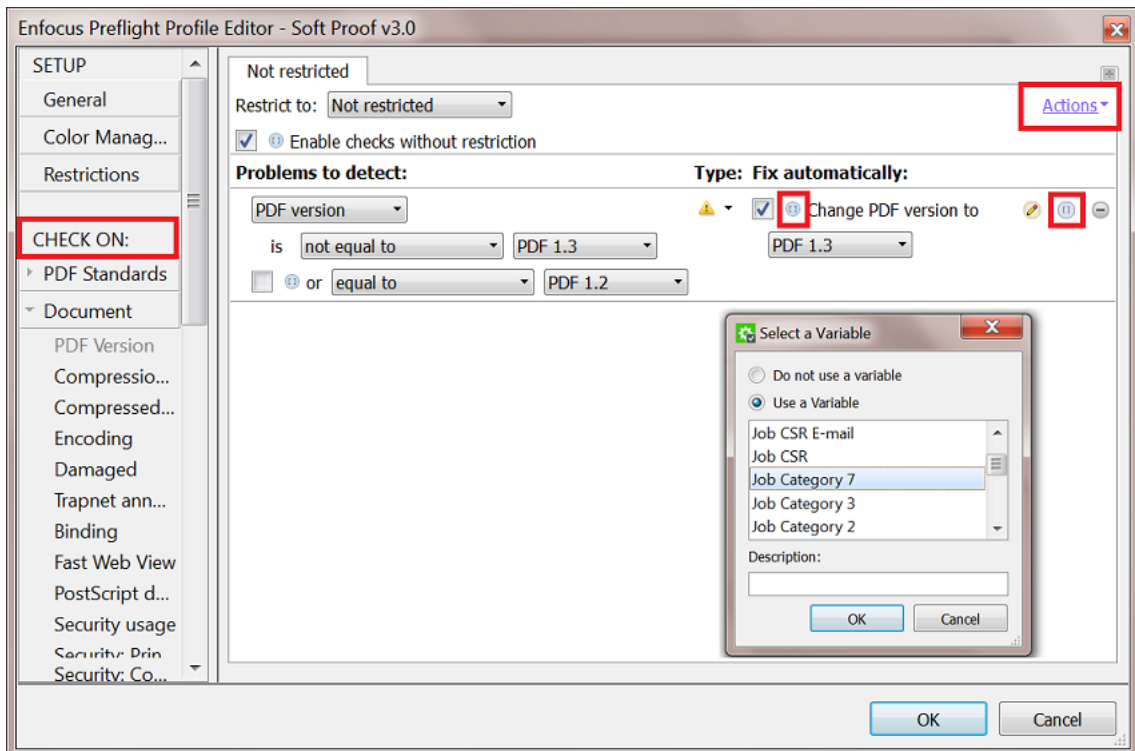

5. Select a **Variable** (SmartName) and click **OK**.

You can use a SmartName in fields that require

- text
- numbers
- measurements with a size in "mm", "cm", "in", "p" (picas) or "pt" (points)



**Attention:** Measurements needs to include the unit! For example "210 mm". When no unit is specified, it assumes **points** as unit.

For example, to represent A4 dimensions, the SmartName should resolve to "210 mm" and "297 mm". If the SmartName resolves to "210" and "297", the dimensions will be seen as 74 mm x 105 mm .

- a toggle that sets a check-box to on or off.
  - Off = a SmartName value "0", "FALSE" or empty.
  - On = a SmartName value "1", "TRUE" or anything else.

### 15.3.3. Preflight with PitStop Task

#### Basics of the Preflight with PitStop task

The **Preflight with PitStop** task allows you to preflight a PDF file in Automation Engine using technology from Enfocus.

This task uses the latest [Enfocus PitStop Server preflight technology](#) (its version number is mentioned in the [report](#)). [This KB article](#) shows which version of PitStop is used internally in this task.



**Important:** While Automation Engine shares the same components as Enfocus PitStop, not all functionality is available (in the same way). Note these limitations:

- In the Automation Engine PitStop Profile Editor, it is not possible to use the font picker and color picker.
- The action 'Select art and create outline path' is not supported by this task.



**Attention:** When the input file is a normalized PDF, the task does not allow to run **profiles** with the option "**Allow Fixes**" selected. It then also does not allow to run **action lists**, regardless whether these actions change the file or not.

### Preflight Result States

As a workflow step, this task by default offers four output pins where your input files can end up (hover your cursor over a pin to see its default name):



- **Finished OK:** When the preflight resulted in an OK status (no warnings or errors were found).
- **Finished with Warnings:** When the preflight resulted in warnings (but no errors).
- **Finished with Errors:** When the preflight resulted in one or more errors.
- **Error:** When the task encounters an error unrelated to the preflight status.

Learn more about controlling task statuses [here](#).

### Preflight Tab

You can use this task to run one or more **Action Lists** and/or run a preflight **Profile**.



**Attention:** An Enfocus preflight profile can also contain action lists.

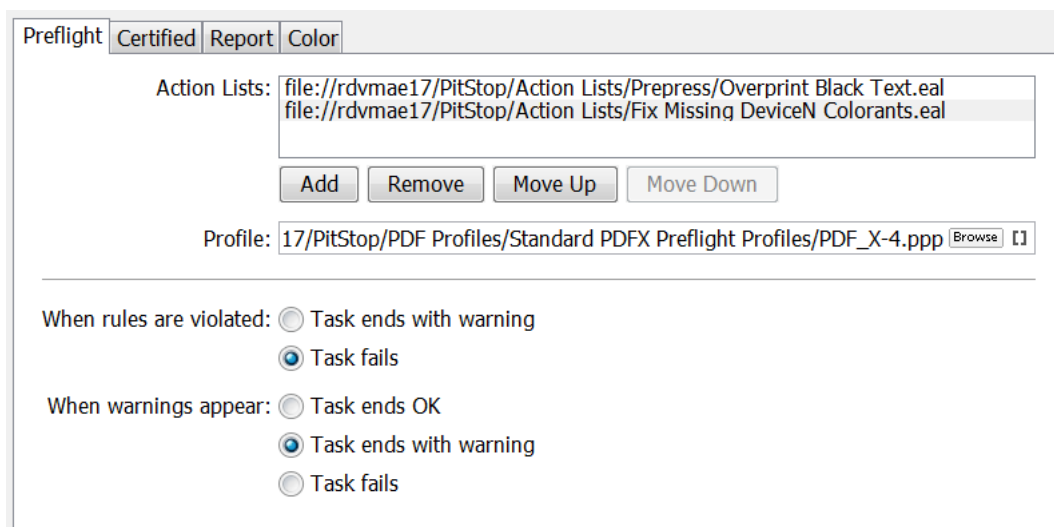

You can create action lists and profiles in the [PitStop Profile Editor](#) that comes with Automation Engine.

- **Action Lists:** Use **Add** or **Remove** to define which action lists you want to run. Use **Move Up / Down** to change the order in which they will be executed.
- **Profile:** If you want to check the PDF against a profile, select a preflight profile from the list.



**Note:** You can use **Variable Names** inside profiles or action lists. This makes the profile or action list 'smart'. Learn more about this concept of **Smart Preflight** in [Smart Preflight: Using Variable Names in PitStop Profiles](#) on page 1148

### Extra Task Status Options When Used as a Single Ticket

When you open a single ticket (when it is not a step in a workflow), extra options appear (as in above screen shot):

- In **When rules are violated**, choose what happens when preflighting results in errors: **Task ends with warning** or **Task fails**.
- In **When warnings appear**, choose what happens when preflighting results in warnings: **Task ends OK**, **Task ends with warning** or **Task fails**.



**Attention:** Learn more [here](#) about controlling the statuses when this task is a workflow step.

## Certified Tab

### Concept of Certification

Certifying a PDF means that you embed a 'proof of preflight' in the PDF. The generator of a PDF can so embed a proof of having done a preflight with a specific profile.

The receiver of that PDF (for example a printer) can then check whether the generator did this required QC step before sending him that file. Some industry partners may even only accept PDF files with specific PitStop Certifications.

Here is an example of how a certification is documented on board the preflight report:

Processing	
Certified PDF status	Preflighted successfully
Preflight Profile	Soft Proof v3.0 Easy
Created by	Enfocus Customer Support - Digimagic Inc. Enfocus - Digimagic Inc.
Pages processed	1
Application used to preflight	Automation Engine 14.1.0 powered by Enfocus PitStop 13 update 1
Application used to create the report	Enfocus PitStop 13 update 1
Preflighted on	UTC: November 30, 2015 - 13:55:25 [ November 30, 2015 - 14:55:25 ]

Whereas a regular PDF only contains Acrobat metadata, an Enfocus Certified PDF contains a lot of additional information ("Enfocus metadata"), such as the used preflight profile and the version history.

You can also use this task to remove an (earlier made) certification or to insist to keep it.

The certification itself can be checked separately by the [Verify Certification task](#), for example at the start of the workflow at the printer.



**Note:** To learn more about the certification concept and workflow, search for "Understanding Certified PDF" in the [PitStop \(Pro / Server\) reference guides](#).

### Options

- Set **Certify** to
  - **Make Certified** to certify the file according the profile selected in the tab "Preflight".
  - **Keep Certified** to preserve the existing (un)certified status of the file.
  - **Make Uncertified** to remove all the certified information from the file.

When choosing **Make Certified** or **Keep Certified**, you can define these extra parameters:

- Add a **User** name, **E-Mail** or **Session Comment** to the certified PDF.
- **Allow to roll back**: Enable this if you want the users to be able to roll back to previous versions of the file (for example to compare). When you disable this, the certification history will still be in the file but users can not roll back to previous versions.



**Attention:** Because the **roll back** option stores extra data, the PDF file size can increase drastically.

## Report Tab

- Decide if you want to **Generate a report** and where this **Report** should be written.
- **Settings for the generated report:**
  - **Units:** Choose from **Inch, mm, cm, Point** or **Pica**.
  - **Language:** Choose one from the list.
  - **Type:** Choose if you want a PDF or XML report, or both.

### Preflight Report Contents

A preflight report contains the **Errors** and **Warnings** found during the preflight, and also lists the **Fixes** it may have done.

An example of the first page of a PDF report:



**Errors were found on page 1 and in general document properties**

- Document contains layers
- Document uses 0 separations, should be equal to 1
- Transparent objects have been found (1x on page 1)
- Resolution of color or grayscale image is less than 250 dpi (1x on page 1)
- RGB color is used (1x on page 1)

**Warnings**

- Compression ratio of image is more than 10 (1x on page 1)

**Fixes**

- Removed marked content (2x on pages 1-2)
- Removed form fields (1x on page 1)



**Tip:** You can make reports appear on their own task status output pin. Learn more in [Configuring Output Statuses](#) on page 743.

**Color Tab**

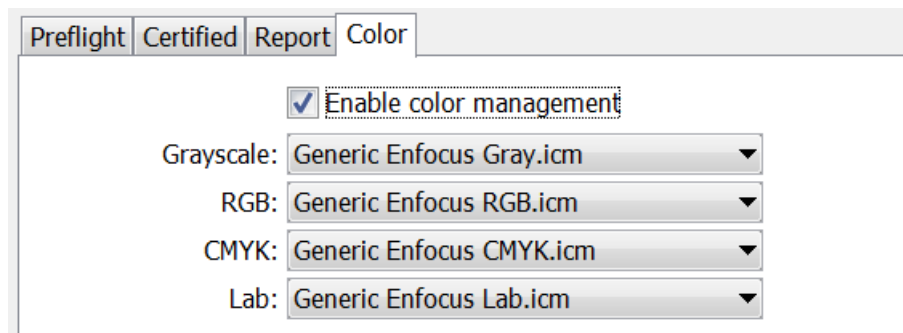

Preflighting often includes color conversions. Unlike normalized PDFs, native PDFs can contain objects in RGB or device independent color spaces.

When the action list or profile includes a color conversion, you can here specify the default ICC profile that will be used for objects that were not tagged with one yet.



To do so, select **Enable Color Management** and choose an ICC profile for the object types in **Grayscale**, **RGB**, **CMYK** or **Lab**.

### 15.3.4. Verify Certification Task



**Note:** The concept of certification is described [in this page about the tab 'Certify' in the 'Preflight with PitStop' task](#).

Certifying a PDF stores the preflight information on board the PDF file. This includes the preflight profile, the preflight report and the information whether the PDF has subsequently been modified.

If you do not re-certify a PDF after it has been modified, it is no longer certified.

You can certify a PDF using **PitStop Pro**, PitStop **Server** or by using the ['Preflight with PitStop' task](#).

The **Verify Certification** task checks if the PDF file was certified to comply with the settings of the profile that you indicated in **Verify against a Profile**.

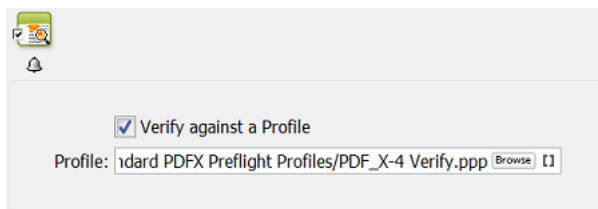

The task's status will be **'Verification OK'** when the profile that was used to certify the PDF is identical or stricter than the profile selected in this task.

## 15.4. GlobalVision Inspection Tasks

---

### 15.4.1. Introduction

Automation Engine offers a set of tasks that use technology from the company [GlobalVision](#):

- [Inspect Artwork](#) compares files.
- [Inspect Barcodes](#) detects and decodes barcodes in the file.
- [Inspect Braille](#) detects and decodes braille in the file.
- [Inspect Spelling](#) checks spelling (of a chosen language).
- [Inspect Text](#) checks text rules.

#### Profiles

Several of these tasks ask you to select an inspection **Profile**.

You can change and create such profiles using the standard profile editor from GlobalVision.

### These Tasks Require a Software License from GlobalVision

To enable these **Inspection** tasks, you need to get a license from GlobalVision and then have it installed on Automation Engine. You can also purchase this license via Esko, as a subscription.

Learn more in [the Configure panel where you do this](#).



**Attention:** Your GlobalVision **license is checked every time you launch** an inspection task by GlobalVision. This means that your server needs internet access to run these tasks.



**Note:** Since AE 21.03, the GlobalVision SDK is more up to date, the licensing activation was simplified and the profile editor now needs to be the standard one from GlobalVision.

## 15.4.2. Recurring Options in GlobalVision Tasks

The following options are available in several GlobalVision tasks:

### Resolution

Several tasks first rasterize the files to RGB files and then inspect that data (PNG files). This option allows you to define the resolution of these RGB images. The minimum supported resolution is 72 ppi, the maximum is 2400 ppi.



**Note:** The default resolution is 300 ppi. Do not set this higher when it is not necessary. Creating high resolution raster data is a significant load for the server. See this other note with [specific information about a different resolution that is used to inspect barcodes](#).



**Note:** Low resolutions like 72 ppi may not be good enough to detect differences. Especially braille needs a higher resolution.



**Note:** These RGB images are written in a central temporary folder that is automatically deleted when the task ends successfully.

### Region

This option allows you to indicate the region in the master file that you want to have inspected. All artwork outside that region will be ignored during the inspection. This region can be rectangular or have the shape of a (die-)line.



**Tip:** Smaller regions will also create smaller rasterized data and so speed up the inspection. This is also true when you select or ignore specific inks or layers (see below).



**Note:** In case of the [Inspect Artwork task](#), this is the region of the master file that you want to compare with the sample file(s). Adding to below mentioned general rules, learn more specifics in [Compare Artwork Tab](#) on page 1163.

Several regions match to the standard PDF page boxes:

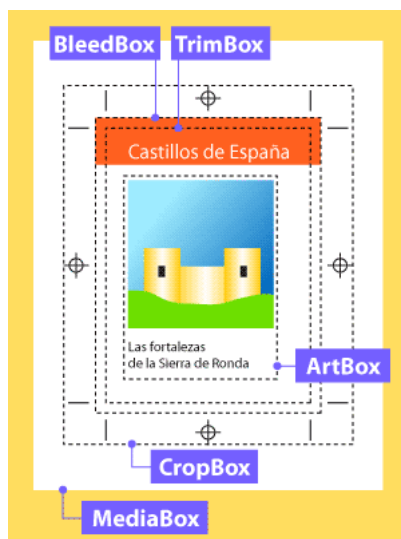

- **Trim Box.** The area after cropping to an area with all content. When no trim box is defined, the crop box will be chosen. When no crop box is defined, the media box will be chosen.
- **Media Box.** This is the entire "real" page and may be larger than the actual crop box.
- **Visible Objects.** Automatically crops to the area with all content, starting from the crop box.
- **Crop Box.** Adobe Acrobat uses this size for screen display and printing. When no crop box is defined, the media box will be chosen.
- **Shape.** Locates the largest object in center of the master file and uses that shape as region. This might be a rectangle or a circle (labels, pages...) or a specific shape typically defined by a die-line (boxes). An example:



Alternatively, you can define the shape in the **Options...** dialog:

- Define shape by **Inks**. Use this when you want to specify the shape by using the bounding box of all data in the here defined ink. You here typically define the ink of the die line. All objects inside the shape (contour) that can be formed out of the data in that ink will be inspected. Process inks are not supported to define a shape.

Click on  to get a list of the inks of the input file. Use Ctrl/cmd- or Shift-select to select multiple inks.



**Note:** In case of the *Inspect Artwork* task, although you here selected them from the input file, the ink(s) will serve to find a region in the master file.



**Note:** The input field is not case sensitive.



**Attention:** When specifying multiple inks (for example "die, cut, knife"),

- only the first one of which a shape can be made will be used.
- when none of them can be used as a shape, the task will result in an error.

- Define shape by **Layers**. Similar to above **Inks**. All objects inside the shape (contour) that can be formed out of the data in that layer will be inspected.

### Ignoring Ink or Layers

Ignoring an ink or layer means that their data will not be part of the raster image and so not part of the inspection.

- **Ignore Inks.** Click on  to have them read from the task input file (you can multi-select in this dialog). Use this for example if you have made a difference in the ink used for text. In such case, you could here choose to ignore that ink to check if there are any unwanted differences in the other inks.
- **Ignore Layers.** Same as above "Ignore Inks", but to ignore layers. You can for example ignore the layer that contains the images.



**Attention:** It is also common to here ignore the ink or layer that was used to define a region based on a shape. For example: inspect the region defined by the shape of the ink "die line" and also here also add the ink "die line" to ignore it from the comparison.

### Report

All "Inspect" tasks write report(s).

- **Report File.** Define the report's location and name. When you use SmartNames to define a relative path, the report will be created relative to the parent folder of the input file. The task will fail when the report tries to overwrite the input file.



**Tip:** You can configure an extra output pin to see the report appear on its own pin. Learn more in [Configuring Output Statuses](#) on page 743.

- **Report Type.** Choose whether you want a PDF and/or an XML report.
  - A PDF report contains several pages, showing and describing what it found during the inspection. The first page shows the bounding box of the region that was inspected.  
The first page of the report shows a preview of the RGB data. It also shows bounding box around the region that was inspected (in pink). When any inks or layers were ignored, this data will also not be shown here.
  - An XML report contains the file URLs and details of what was found during the inspection.

- **Add annotations output pin.** This will add an extra workflow step output pin so it becomes possible to launch specific tasks on the XFDF annotation file (if the type of task writes it). learn more about working with these annotation files in [Inspection Results as Annotations in Viewers](#) on page 1159.

### 15.4.3. Inspection Results as Annotations in Viewers

The five GlobalVision Inspection tasks generate XFDF files that contain inspection annotations. These XFDF files are written in a hidden subfolder.

These annotations show up in the Automation Engine Viewer (and in the WebCenter Viewer). Learn more in [Working with Annotations](#) on page 1139.

#### Seeing Inspection Annotations in the WebCenter Viewer

There are 2 ways to see the annotations in the WebCenter Viewer:

- When publishing an inspected file from Automation Engine to WebCenter.
- When launching the inspection from WebCenter itself.

#### Publishing an Inspected File to WebCenter

When you ran an inspection task in Automation Engine and you then use the [Publish on WebCenter task](#), you can select its option **Publish Annotations** to make sure that also the XFDF file is published to the chosen WebCenter project.

When you then view the document in the WebCenter Viewer, the annotations will also be visible.

#### Launching the Inspection from WebCenter

In this case, WebCenter triggers the inspection(s)(and creation of the XFDF). It does this as part of a **WebCenter Task** that triggers a workflow on its own OBGE (or on an external Automation Engine).

We illustrate this workflow by means of an example:



**Attention:** This example assumes you are familiar with creating WebCenter Tasks. Learn more in the [WebCenter documentation](#).

Here are the main steps to set up this workflow:

1. In your WebCenter project (template), define a WebCenter **Task** that contains a **Submit Workflow** that will launch the inspection task(s) on a graphics file.
2. The **Submit Workflow** step in that WebCenter **Task** links to a workflow that uses inspection tasks where you configured an extra output pin in for the annotation file. This XFDF file is so forwarded to the **Integrate with WebCenter** task (more details on this task in below steps). For example:



- The **Submit Workflow** step in that WebCenter Task needs to use the **Workflow Parameters "Add Document properties"** See an example:

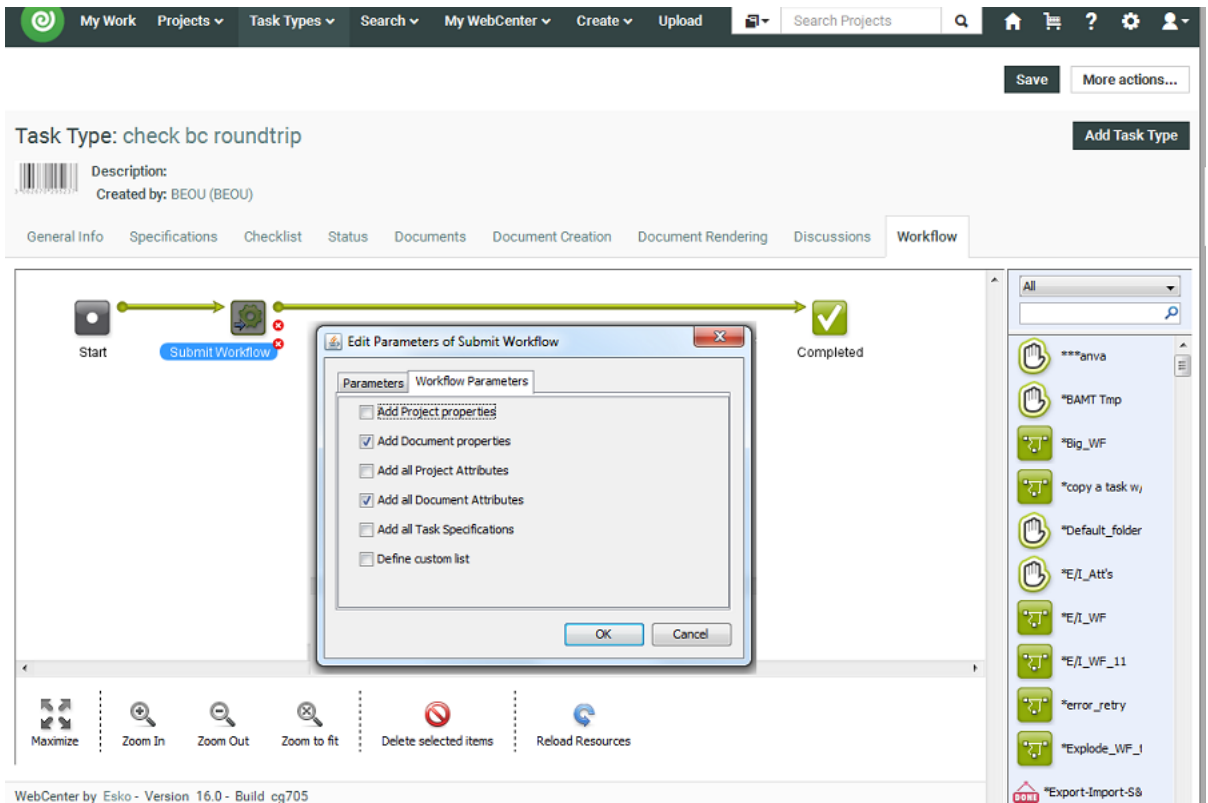

Optionally, also use **Add all Document Attributes**. This can for example be useful to communicate the document's language to the spelling inspection.

- In workflow that is being submitted, in the **Integrate with WebCenter** ticket(s), the **action "Upload Document Annotations"** is used.

In the **Options** of that action, use the workflow parameter `[wfp.document.versionid]`. This is needed to associate that (set of) annotations with that document version. An example:

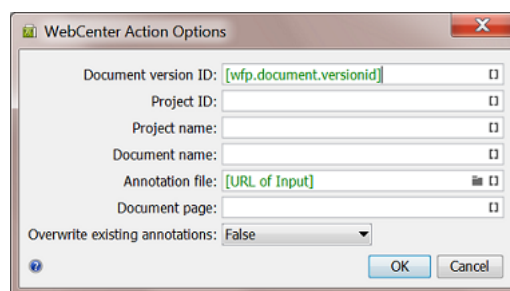

## 15.4.4. Inspect Artwork



**Note:** This is one of several inspection tasks that use technology from the company [GlobalVision](#). Learn about the general concept and setup in the [Introduction](#) on page 1155.

### Concept and Workflow

#### Concept

This task compares one or more 'sample' files to a 'master' file. It selects the defined region of interest, aligns the files and then compares them. It supports multi-page inspections as well as step & repeat files.

Comparing files is typically done

- to make sure files are identical when you ignore a specific ink or layer.
- to make sure only the intended differences are there.

The task detects these types of differences:

- Text changes (moved, missing, broken, added)
- Font changes (size, style)
- Graphics (deletion, insertion, change)
- Color
- Registration

#### Technique

The task prepares RGB raster data of the sample and master file at a custom resolution and then compares that raster data.

This task compares colors, meaning the way as if a human eye or a camera or a scanner looks at the files. For example if the task sees that a green object is the exact same color in both master and sample file, it will not see this as a difference, no matter what separations that green color is made up of.



**Note:** In the Automation Engine Viewer, the default compare mode is one that compares separations ('channels'). In that mode, the Viewer will detect a difference if the same green object is in one file made up of a Pantone ink and in the other file a mix of CMYK. The Viewer also offers the mode to compare HSV values, which is similar to the mode this task uses.



**Note:** This task is similar to the [Compare PDF \(Classic\)](#) task.

The found differences are mentioned in the report file but are also written as an XFDF file (a standard Acrobat comments file). When you open the inspected sample file in the Automation Engine Viewer, the viewer will read this XFDF file and show its contents in the annotations list. Learn more in [Working with \(GlobalVision\) Annotations](#).

### Smart comparing

The task automatically uses these features:

- Rotation detection. The task detects if the sample file is a rotated version of the master file and takes this into account when inspecting.
- Skew correction and alignment. This is for example useful when one of the files is a scan that was slightly angled when being scanned.
- Repeat detection. The task automatically detects if a file is a repeated area inside the other file. Such detected repeats are mentioned and shown in the report file.

### Supported File Types

The sample and the master files can be any of these file types:

- PDF
- Normalized PDF
- PDFPLA
- AI Adobe Illustrator (when PDF compatible)
- TIFF (1-bit and 8-bit. Multichannel images are not supported)
- LEN
- JPEG
- PNG
- BMP
- Folder

### Detailed Reporting

A detailed PDF report lists and visualises the found differences. An XML report details the coordinates of where differences were found. Learn more in [Report Tab](#) on page 1164.

### Status and Workflow Output Pins

The sample file (task input file) is also the task output file. This makes it easy to continue your workflow with this file. It will be placed on one of these output pins:

- **Match.** When no differences were found.
- **Mismatch.** When one or multiple differences were found.
- **Error.** When the task itself could not function properly. For example when no [profile](#) was selected, when the master file could not be found or when the files could not be matched.

See an example (to help visualize the output pins, an end status step was created with the same name as the status):



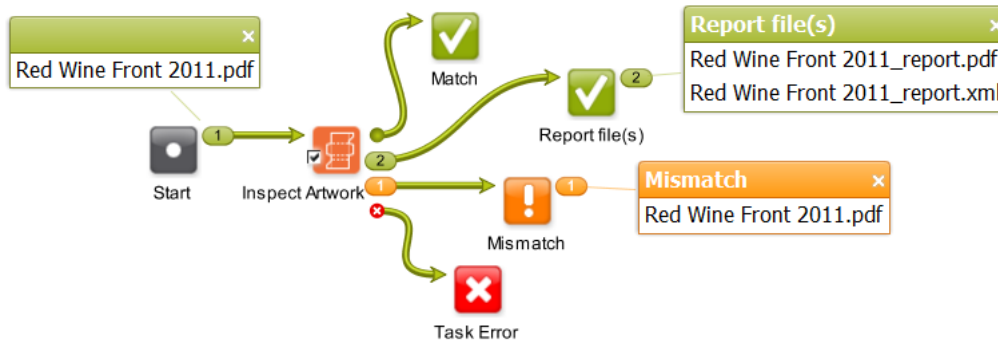

**Tip:** To get that extra output pin for the report(s) as in above example, you will need to configure it as mentioned in [the page about the inspection report](#).

### Integration with Automation Engine Viewer

When opening the sample file in the Automation Engine Viewer, the area where differences were found are shown in red rectangles and automatically become part of the **Annotations list**. Learn more in [Working with \(GlobalVision\) Annotations](#).

### Compare Artwork Tab

- **Compare With.** Indicate the master file you that want to compare your input sample file(s) with.



**Note:** This field needs a full URL (path). When using SmartNames, make sure you also define a file extension.

When the task input is a folder, you here also need to define a folder. The first file in the master folder is compared with the first one in the sample folder. The second master one to the second sample one, etc. When the amount of files in the input folder is not equal to that in the master folder, the task ends in error. The task does not check files in subfolders.

- **Compare Resolution.** This option is present in several GlobalVision tasks. Learn more in [Generic Option "Resolution"](#).
- **Profile.** An inspection profile is a collection of parameters that define how (precise) to inspect. Profiles differ (slightly) in thresholds of what you consider as differences. They are centrally located \*.ini files that you can adapt using the [GlobalVision Profile Editor \(OUTDATED\)](#) on page 1175. You can there both adapt the default inspection profiles or create your own.



**Attention:** The profiles listed below are the default ones from GlobalVision. You might use a (test-)version that already offers other profiles that were fine-tuned for Esko prepress workflows.

- **None.** The task will end in error when you do not select a profile.
- **Booklet.** Choose this setup to compare multi-page files. It will compare all pages of the sample file with each same-number page of the master-file. Alternatively, for a slightly more precise inspection, choose **Digital** and select **Multipage**.
- **Digital to Scan.** Choose this profile to compare a digital artwork file to a scanned master file.
- **Digital.** Choose this profile to compare revisions or variations of digital artwork.

- **Proof.** Choose this profile to compare files that are supposed to be the same. This is typically to compare digital artwork against a digital proof. Also use it to compare a proof against a printed hard copy. This profile uses refine, auto distort and smoothing to compensate for changes in the image.
- **Scan to Scan.** Choose this profile to compare scanned files.



**Note:** The parameters of the chosen profile are listed on the last page of the [report](#).

- **Multipage.** By default only the first page of a document is inspected. Select this option to compare all pages of the input multi-page sample file to each same-number page of the master file.



**Note:** The task will end in error when the sample file and the master file do not have the same number of pages.



**Note:** This option is ignored when the profile 'Booklet' is chosen (or any other custom profile that already uses the multi-page parameter in its configuration).

- **Region.** This option is present in all GlobalVision tasks. Learn its basics in [Generic Option "Region"](#). As this task has both a master and sample file(s), these following notes are important:



**Note:** When using a region based on a **Shape**, the task looks for the content of the defined shape in the master file and looks for that similar content in the sample file. This also done when choosing regions based on **Trim** or **Media Box**: the content in that box of the master file will be looked for in the sample file and then compared.



**Attention:** Even when you select an ink or layer from the list of those in the input sample file, this ink or layer is used to find a shape in the master file.

- **Ignore Inks** and **Ignore Layers.** These options are present in several GlobalVision tasks. Learn more in [Generic Options "Ignore Inks or Layers"](#).
- **Configure.** This button opens the item in the configure panel where you can activate the software license that you acquired from GlobalVision.

## Report Tab

This option is present in several GlobalVision tasks. Learn more in [the Generic Option "Report"](#). We here only mention some specifics for this task.



**Attention:** The last page of the PDF report summarizes the parameters of the profile chosen in the task ticket. Any parameters that were chosen separately in the Esko ticket (like resolution), and that overruled parameters in that profile, are not mentioned here. This means that the here mentioned 'Desired DPI' is possibly not the one that was really used for inspection.

### 15.4.5. Inspect Barcodes



**Note:** This is one of several inspection tasks that use technology from the company [GlobalVision](#). Learn about the general concept and setup in the [Introduction](#) on page 1155.

## Concept and Workflow

This task inspects all barcodes in a file. It scans and decodes them and verifies their grade (quality level) against the minimum grade chosen in the ticket.

A barcode quality problem could for example be that it is too small or it could have too little color contrast, a QR code could miss some parts, etc.

You can also check if the barcodes defined in the Product or Job database are present in the file.

The main advantage of this task is that you do not have to open these files and check them visually or use a device to verify them. The detailed report is also a useful step in your quality control process.



**Note:** You can use the [GlobalVision Profile Editor](#) to compare barcodes in a master and sample file.

This task also checks the barcode "quiet zones". For 2D barcodes, a specific grade is given for these zones, one for each side, 100% when the zone is big enough.

## Supported Barcodes



**Attention:** Add-on codes and composite codes are not supported. UPC-A or EAN-13 add-on codes are recognized but are not graded.

- **1D/Linear codes:**
  - PharmaCode
  - RSS/GS1 Databar Omnidirectional Stacked
  - RSS/GS1 Databar Expanded
  - RSS/GS1 Databar Limited
  - RSS/GS1 Databar Stacked
  - RSS/GS1 Databar Expanded Stacked
  - RSS/GS1 Databar Omnidirectional
  - RSS/GS1 Databar Truncated
  - UPC-E
  - UPC-A
  - EAN 13
  - EAN 8
  - Code 39
  - Code 93
  - Code 128
  - GS1 128
  - MSI
  - Interleaved 2 of 5
  - Codabar
  - ITF-14
  - ITF-16
  - Telepen (only decoding supported)
  - Code 11 (only decoding supported)
  - UPC-A add-on codes (only decoding supported)
- **2D codes:**

- Data Matrix
- GS1 Data Matrix
- QR
- MicroQR

### Detecting Rotated Barcodes

For linear barcodes, the option "Support Rotation" in the profile needs to be enabled in order to be guaranteed that a rotated barcode is detected. If the option is not enabled, linear barcodes can only be detected when in 0, 90, 180 and 270 degree angles.

However, because linear barcodes can be sheared, it is possible that rotated barcodes are still detected even if the option "Support Rotation" is not enabled.

Rotated 2d barcodes with an angle other than 0, 90, 180, 270 degrees can not be guaranteed to be detected.

### Supported File Types

The input file types supported by this task are the same [as described here for the Inspect Artwork task](#), here excluding the type 'Folder'.

### Status and Workflow Output Pins

The task input file is also the task output file. It will be placed on one of these output pins:

- **OK.** When all barcodes conform to the chosen minimum barcode grade and, when that option is selected, all the barcodes described as product or job barcode are found (with their specified parameters). Learn about these options in [this next page](#).
- **Not OK** (status 'Warning'). When one or more barcodes do not conform to the chosen minimum grade, or, when that option is selected, when a barcode described as product or job barcode is not found or has different parameters. This is also the status when the input file has no barcodes.
- **Warning.** When all barcodes conform to the chosen minimum grade, and, when that option is selected, when a barcode described as product or job barcode is not found or has different parameters.
- **Error.** When the task itself could not function properly. For example when no [profile](#) was selected, or no license was available.

See an example (to help visualize the output pins, an end status step was created with the same name as the status):



**Tip:** To get that extra output pin for the report(s) as in above example, you will need to configure it as mentioned in [Configuring Output Statuses](#) on page 743.

### Integration with Automation Engine Viewer

When opening the inspected file in the Automation Engine Viewer, the detected barcodes are indicated in red rectangles and is detailed in the **Annotations list**. Learn more in [Working with \(GlobalVision\) Annotations](#).



**Note:** Due to used resolutions, small differences can occur when comparing BWR measured by the task with BWR measured interactive in the AE Viewer. Learn more [here](#).

### Check Barcodes Tab

- **Minimum Grade.** Select the minimum grade (quality level) to which all found barcodes must comply. Choose a letter or a number. Numbers deliver more detail. Learn more below and in the [GlobalVision Profile Editor \(OUTDATED\)](#) on page 1175.
- **Grades in Letters (ISO 15416:2000)**

Table: Overview of Barcode Grades in Letters

Grade	Meaning
<b>A</b>	These barcodes should scan easily the first time with most scanning equipment. The aim should be to produce codes of this quality whenever the printing processes and materials allow this.
<b>B</b>	Codes of this quality may read after a single scan. If a second scan is required, the probability of success is very high.
<b>C</b>	This is the minimum quality that most barcodes should achieve. It means that re-scanning might be required to get a successful read. Flatbed scanners, which read the barcode at several places, are recommended with codes of this quality.
<b>D</b>	This grade is only acceptable for ITF-14 barcodes printed on fiberboard.
<b>F</b>	F is fail.

### Barcode Individual Grade Parameters (Letters)

The overall grade of a barcode is determined by its individual grade parameters. The overall grade is equal to the lowest grade of any of these individual ones:

Table: Value of Individual Grade Factors in overall Barcode grade (Letters)

Barcode Group Type	Individual Grade Parameter	Meaning
<b>1D/Linear</b>	<b>Minimum Reflectance</b>	Pass or fail grade (A or F) and the min reflectance value (darkest part of the barcode).
<b>1D/Linear</b>	<b>Symbol Contrast</b>	The difference in contrast between the darkest and the lightest part of a barcode (%).
<b>1D/Linear</b>	<b>Minimum Edge Contrast</b>	Pass or fail grade (A or F) determined by the minimum contrast between a space and its adjacent bars.
<b>1D/Linear</b>	<b>Modulation</b>	The ratio between symbol contrast and minimum edge contrast.

Barcode Group Type	Individual Grade Parameter	Meaning
1D/Linear	Defects	The amount of discrepancies in the reflectance of a barcode.
1D/Linear	Decode	Pass or fail grade (A or F) determined by whether the barcode was generated correctly (i.e. sufficient spacing between bars).
1D/Linear	Decodability	The ease of barcode identification.
2D	Modulation	The contrast difference between light and dark regions.
2D	Decode	Pass or fail grade (A or F) determined by whether the barcode was generated correctly (for example sufficient spacing between bars).
2D	Axial Non-Uniformity	The difference in length of the two axis of the barcode.
2D	Grid Non-Uniformity	The vector deviation of the barcode from an ideal position.
2D	Fixed Pattern Damage	The damage done to the pattern of a barcode.
2D	Unused Error Correction	The amount of unused error correction embedded in the barcode.

- Grades in Numbers (ISO 15416:2016)**

This new calculation method can in some cases result in a higher averaged score for the above parameters using this interpolation method compared with the method using letters (ISO 15416:2000).

Find more details about the decimal grades method in [http://www.aisvision.com/files/2815/1602/9515/ISO\\_15416\\_December\\_2016\\_Changes.pdf](http://www.aisvision.com/files/2815/1602/9515/ISO_15416_December_2016_Changes.pdf) and in <https://www.sis.se/api/document/preview/921309/>.

There are 41 possible grades: 0.0 , 0.1, 0.2 up to 4.0 (source <http://www.axicon.com/fractional-grading.html>).

**Table: Value of Individual Grade Factors in overall Barcode grade (Numbers)**

Grade	Symbol contrast	Modulation	Decodability	Defects	Decode	Rmax/Rmin	Min. Edge Contrast
0.0	< 15%	< 30%	< 20%	> 30%	Fail	< 2	< 15%
0.1 to 0.9	15% to 19%	30% to 39%	20% to 24%	NA			
1.0 to 1.9	20% to 38%	40% to 49%	25% to 36%	26% to 30%			
2.0 to 2.9	39% to 54%	50% to 59%	37% to 49%	21% to 29%			

Grade	Symbol contrast	Modulation	Decodability	Defects	Decode	Rmax/Rmin	Min. Edge Contrast
3.0 to 3.9	55% to 69%	60% to 69%	50% to 61%	16% to 20%			
4.0	>= 70%	>= 70%	>= 62%	<= 15%	Pass	>= 2	>= 15%

- Profile.** An inspection profile is a collection of parameters that defines how (precise) to inspect. They are centrally located \*.ini files that you can adapt using the Esko tool "[GlobalVision Profile Editor](#)". You can there both adapt the default inspection profiles or create your own.

When unsure, use the **Default** profile. Selecting **None** will result the task to end in error.

- Compare barcode data with job or product barcode data.** When this option is selected, the task will, after having checked the minimum grade, also check if all barcodes specified in the [Product Part Properties](#) or in the [Job Setup](#) of the input file are present as such in this file. Not just their type or code, but also all the other parameters entered in those product or job parameters.

This table shows you how the terms in Automation Engine's product and job parameters map to the terms used by GlobalVision (that are also used in the reports).

Automation Engine term	GlobalVision term
BOBST	Laetus Pharma Code
CLF-8	Laetus Pharma Code
CODABAR	Codabar
CODE-128	Code 128
CODE-39	Code 39
CODE39_EXTENDED	Code 39
DATAMATRIX	DataMatrix
EAN-13	EAN 13
EAN-8	EAN 8
GS1-128	GS1 128
GS1_DATABAR-OMNIDIRECTIONAL	GS1 Databar Omnidirectional
GS1_DATABAR-EXPANDED	GS1 Databar Expanded
GS1_DATABAR-EXPANDED_STACKED	GS1 Databar Expanded Stacked
GS1_DATABAR-LIMITED	GS1 Databar Limited
GS1_DATABAR_STACKED	GS1 Databar Stacked
GS1_DATABAR_STACKED_OMNIDIRECTIONAL	GS1 Databar Stacked Omnidirectional
GS1_DATABAR_TRUNCATED	GS1 Databar Truncated
GS1_DATAMATRIX	GS1 DataMatrix
GS1_US-COUPON-INTERIM	UPC-A + GS1 Databar Expanded Stacked
HIBC-39	Code 39
HIBC-128	Code 128

Automation Engine term	GlobalVision term
ITF-14	ITF-14
ITF-16	ITF-16
INT_2_of_5	Int. 2 of 5
KURANDT	Laetus Pharma Code
LAETUS_PHARMA	Laetus Pharma Code
MS_7	EAN 8
MSI	MSI
MARKS_AND_SPENCER	EAN 13
NDC_HRI	UPC-A
PLESSEY	MSI
PZN	Code 39
PZN8	Code 39
PARAF_ITALY	Code 39
QR	QR
MicroQR	Micro QR
UPC-A	UPC-A
UPC-E	UPC-E
UPC-SCS	Int. 2 of 5

- **Region.** Learn more about specifying an inspection region in [Generic Options](#).
- **Resolution.** This option is present in several GlobalVision tasks. Learn more in [Generic Option "Resolution"](#). Make sure the resolution is high enough to detect barcodes.



**Attention:** The resolution you can specify here does not influence the accuracy with which the barcode is inspected. This resolution is used to render the complete file before inspecting any barcodes. The higher this resolution, the longer it will take to render the complete file.

To set a high accuracy of inspection of the barcode itself, you can define a higher resolution in the barcode profile that you are using. This can be done via the GlobalVision Profile Editor.

This means that it's possible to inspect the file at for example a resolution of 300 ppi, but that the barcode is inspected at 1.200 ppi.

Setting different resolutions in the profile leads to different results. An example:

An 'Inspect Barcodes' task that inspects at 300 ppi, can result in a narrow bar width of

- 0.48 mm when the profile resolution is set to 300 ppi
- 0.46 mm when the profile resolution is set to 600 ppi
- 0.45 mm when the profile resolution is set to 1.200 ppi.

- **Ignore Inks.** When you are sure your barcodes do not contain specific inks, you can here ask to ignore those inks. This can speed up the task. Learn more in [Ignoring Ink or Layers](#) on page 1158.



- **Ignore Layers.** Same as above, but for layers.
- **Configure.** This button opens the item in the configure panel where you can activate the software license that you acquired from GlobalVision.

### Report Tab

This option is present in several GlobalVision tasks. Learn more in [the Generic Option "Report"](#). We here only mention some specifics for this task.



**Note:** Pharma codes (folder and gluer) return a different number when read upside down. The report mentions both possible numbers. For example "121" might show up as "121 86".



**Attention:** These reports do not include information about the comparison with Product or Job barcode data. Those details are part of the task's log file.

- The **PDF report** first shows a summary of all found barcodes and their grade. It then describes the barcodes in detail.
- The **XML report** also contains all details about the found barcodes.

## 15.4.6. Inspect Braille



**Note:** This is one of several inspection tasks that use technology from the company [GlobalVision](#). Learn about the general concept and setup in the [Introduction](#) on page 1155.

### Concept and Workflow

This task detects braille, translates it to a chosen language and displays information such as the language, number of dots, number of characters, number of lines, dot spacing, character spacing, word spacing and line spacing values.

Braille should comply to the [Marburg Medium braille specification](#). Braille that does not comply might get misinterpreted. For example wrongly grouping dots of different characters into one character, or not detecting certain dots to be part of the braille, or not recognizing the braille at all.

The task can also compare the found braille to a given text.



**Note:** You can use the [GlobalVision Profile Editor](#) to **compare braille** data between a master and sample file.

### Supported File Types

The input file types supported by this task are the same [as described here for the Inspect Artwork task](#), except the type 'Folder'.

### Status and Workflow Output Pins

When finished, the task input file will be placed on one of these output pins:

- **OK.** When no error occurred and when the **compare** option is not enabled.

- **Not OK** (status "warning"). When the option **compare** was used and found a mismatch.



**Attention:** A mismatch will not be shown in the report file (the actual comparison is done with the report data). Mismatches are mentioned at the bottom of the task log file. For example:

```
INFO: GlobalVisionTask.INFO.ComparingWithBrailleData
ERROR: GlobalVisionTask.Message.BrailleDataDifference (< correct text >, < mismatch >)
```

- **Error.** When the task itself could not function properly. For example when no license was available.



**Tip:** To get an extra output pin for the report(s), you will need to configure it as mentioned in [the page about the inspection report](#).

### Integration with Automation Engine Viewer

When opening the inspected file in the Automation Engine Viewer, the detected braille is indicated in red rectangles and is detailed in the **Annotations list**. Learn more in [Working with \(GlobalVision\) Annotations](#).

### Check Braille Tab

- **Language.** Braille is written in a specific language. Some braille characters mean different things in different languages. Select the language in which you think that the braille code is written. You then will get the correctly translated version in that language.



**Note:** A language translation set is an XML file that describes mapping of characters. Some (pharma) companies create their own mapping style. You can use the [GlobalVision Profile Editor \(OUTDATED\)](#) on page 1175 to export and add custom languages.

- **Compare.** Enable this option to compare the text resulting from all the detected and translated braille with the text written in this field or resolved by a SmartName in this field. To indicate a new line in the text, add a space in the text field.



**Attention:** The comparison is done with the text in this field, *not* with text present inside an external file.



**Note:** If your file has separate groups of braille that you want to compare with a text you defined here in this field, you can work with layers. Add the different groups of braille to different layers in your file and use the option **Select Layers** to control which translated braille you here compare with the here defined (smart) text.

- **Region.** Learn more about specifying an inspection region in [Generic Option 'Region'](#).
- **Resolution.** Make sure the resolution is high enough to detect braille. 72 ppi for example will not be sufficient to detect the braille objects. Learn more in [Generic Option "Resolution"](#).
- **Select Inks.** Braille is usually present in a specific ink or layer. Specify one or more inks that contain the braille data. Once braille is found in one ink, all braille is expected to be in that ink (all braille in another selected ink will then be ignored). The list of inks does not determine the order in which the inks are searched.
- **Select Layers.** Same as **Select Inks**, but for layers. Except that when you specify multiple layers, that not just the first (found) layer will be checked.

- **Configure.** This button opens the item in the configure panel where you can activate the software license that you acquired from GlobalVision.

## Report Tab

This option is present in several GlobalVision tasks. Learn more in [the Generic Option "Report"](#).

### 15.4.7. Inspect Spelling



**Note:** This is one of several inspection tasks that use technology from the company [GlobalVision](#). Learn about the general concept and setup in the [Introduction](#) on page 1155.

#### Concept and Workflow

##### Concept

This task checks the spelling of the text in the input file. You need to specify the language the text is written in. This can also be a custom dictionary.



**Attention:** This task only checks spelling of live text objects (not of contoured text).

##### Supported File Types

This task supports PDF, Normalized PDF, PDFPLA, AI (when PDF compatible), TXT, DOC(X), RTF, XML, HTML and XLS(X) files.

##### Status and Workflow Output Pins

When finished, the task input file will be placed on one of these output pins:

- **Match** (status "OK"). When the spelling was correct.
- **Mismatch** (status "Warning"). When the spelling was not correct.
- **Error.** When no live text was found or when the task itself could not function properly (for example when no license was available).



**Tip:** To get an extra output pin for the report(s), you need to configure it as mentioned in [the page about the inspection report](#).

##### Integration with Automation Engine Viewer

When opening the inspected file in the Automation Engine Viewer, the spelling violations are indicated in the **Annotations list**. Learn more in [Working with \(GlobalVision\) Annotations](#).

#### Check Spelling Tab

- **Language.** Select the language the text is written in.



**Note:** You can customize a language (dictionary) by using the [GlobalVision Profile Editor \(OUTDATED\)](#) on page 1175.

- **Region.** Learn more about specifying an inspection region in [Generic Option "Region"](#).



**Tip:** When your file contains live text in more than one language, you could organize the different texts in specific layers and then specify a layer selection in this task.

- **Select Layers.** You can specify one or more layers that contain the text in the selected language.

### Report Tab

This option is present in several GlobalVision tasks. Learn more in [the Generic Option "Report"](#).

## 15.4.8. Inspect Text



**Note:** This is one of several inspection tasks that use technology from the company [GlobalVision](#). Learn about the general concept and setup in the [Introduction](#) on page 1155.

### Concept and Workflow

#### Concept

This task compares the text in the input file with the text in another file. You select a profile that defines how should be compared and what should be seen as a difference (for example if you consider a font type or font size change a difference).



**Attention:** This task only detects and compares live text objects (not contoured text).

#### Supported File Types

This task supports PDF, Normalized PDF, PDFPLA, AI (when PDF compatible), TXT, DOC(X), RTF, XML, HTML and XLS(X) files.



**Note:** For XLS(X) files only the visible text is checked, so not the text outside the visible part of the cell.

#### Status and Workflow Output Pins

When finished, the task input file will be placed on one of these output pins:

- **Match** (status "OK"). When the text matches.
- **Mismatch** (status "Warning"). When the text does not match.
- **Error.** When one of the files has no live text or when the task itself could not function properly (for example when no license was available).



**Tip:** To get an extra output pin for the report(s), you need to configure it as mentioned in [the page about the inspection report](#).

### Integration with Automation Engine Viewer

When opening the inspected file in the Automation Engine Viewer, the found differences are indicated in the **Annotations list**. Learn more in [Working with \(GlobalVision\) Annotations](#).

### Compare Text Tab

- **Compare with.** Indicate the file (full URL) that contains the text that you want to compare with the text from the input file. For example: your input file is a PDF and you compare it with a Word file containing the original text.
- **Profile.** Select a profile that defines what should be seen as a difference and other parameters. Learn more about these profiles in the [GlobalVision Profile Editor \(OUTDATED\)](#) on page 1175.
- **Region.** Learn more about specifying an inspection region in [Generic Option 'Region'](#).
- **Select Layers.** You can specify one or more layers that contain the text.

### Report Tab

This option is present in several GlobalVision tasks. Learn more in [the Generic Option "Report"](#).

## 15.4.9. GlobalVision Profile Editor (OUTDATED)

Since v21.03, the 'GlobalVision Profile Editor' (an Esko-branded version of that editor) is no longer available.

Since 21.03, users should use the standard profile editor application from GlobalVision itself.



**Note:** You can still find documentation of this editor on [versions of the AE manual](#) older than v21.03.

## 15.5. Other QC Tasks

---

### 15.5.1. Check Print Rules (PRC) (Classic)

Print Rule Checker (PRC) is an old technology on board the Esko editor PackEdge. It checks the file, completely or partially, for potential printing problems or violations of standard printing conventions. These checks can include insufficient line thickness, wrong halftone densities, the use of too many inks, and various other production related issues.

This task checks the file according a rule set that you made in PackEdge. The task adds the results of its checks into the Normalized PDF file. When you then open this file in PackEdge, you can quickly see

a full report of these checks and use dedicated tools to quickly navigate to the parts where rules were violated.

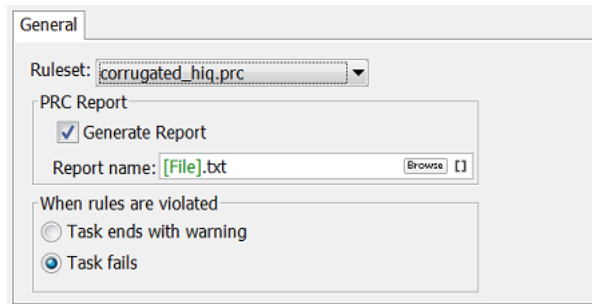



Task options:

- Select the **Ruleset** from the drop-down list. These were created in PackEdge and saved in a default central folder. Learn more about defining such rule sets in [the PackEdge user guide](#).



**Note:** In this background task version of PRC, rules on 'Small Parts' and 'Close Objects' are not checked.

- **PRC Report.** Enable this also get a .txt report that describes the used rule set and the found infringements.
- Decide what the state of the task should be **when rules are violated: Task ends with a warning**  or **Task fails** .

## 15.5.2. Compare PDF (Classic)

### Concept and workflow

This task compares the input PDF file(s) to a reference PDF file. It creates TIFF files of each separation and then compares those.

You can see the found differences in a separate layer or file and also in an XML report.



**Note:** The [Inspect Artwork](#) task also serves to compare files but is more elaborate.

The task can have these output states:

- **Match:** No differences were found.
- **Mismatch:** Differences were found.
- **Error:** The task itself malfunctioned (reference file was not found, no license was available...).

### Task Options

- **Compare**
  - **Compare With.** Define the reference file with which you want to compare the input PDF file(s).
  - Select the **Compare Region** (of both input and reference file) within which you want to compare. Learn more about page boxes [here](#).

- Set the **Compare Resolution** for the automatically created TIFF files. Enter a value between 50 and 300 ppi.
- Set the **Noise Tolerance**. The compare resolution defines in what *detail* you compare the files. This noise tolerance however defines how *strict* you want to compare: what do you consider as a difference? If you do not want the most strict form, you can here define a tolerance.

The distance in this field represents the maximum (horizontal or vertical) distance between isolated pixels for them to be ignored. An isolated pixel is a pixel that is different in both files but that has all surrounding pixels equal in both files. The higher you put the value, the more tolerant you are against noise. The more you allow noise, the less strict the comparison will be. The default is '0 mm' (no differences allowed, most strict).

An example: A comparison shows 2 isolated pixels that are 10 mm apart and also 2 isolated pixels that are only 2 mm apart. If you now set the noise tolerance to '5 mm', then the set of isolated pixels that are 10 mm apart will be ignored in the comparison.

- **Ignore Separations**. Add the names of separations to ignore during the comparison. For example for multilingual variants you may want to ignore the separation(s) that contain(s) text.



**Tip:** Double-click on a line in the canvas and use the small drop-down list to select separations of the ticket's input file.

• **Differences**

- **Output in:** Define the folder where you want to save the file containing the found differences and the report file. When you type in a name, it will be created as a subfolder of the input file.



**Note:** This field is thus only valid when you enable one or both of the below options.

- Select **Create Differences layer** if you want to add the found differences in a separate layer.



**Note:** When page boxes are different and/or separations do not match, the task will report a mismatch but will not create a difference layer.

In **Layer File**, when you use the SmartName `[File]`, the extra layer will be added to your input file. Alternatively, you could browse to an existing PDF file or use SmartNames to have a new one created automatically, for example `"[file]_Diff"`.

- Select **Report differences to file** to save the differences in a separate XML report file. This XML file has the extension \*.comp. When the files don't match, this report contains the coordinates of the mismatched pixels for each separation.



**Note:** In the Esko editor Neo, you can insert these .comp files on top of the opened PDF to see the coordinates of where differences were found.



**Tip:** You can configure an extra output pin to see your report appear on its own pin. Learn more in [Configuring Output Statuses](#) on page 743.

## 16. RIP'ing with Imaging Engine

---

### 16.1. What is Imaging Engine?

---

#### An Adobe PDF Print Engine Based RIP

Imaging Engine is Esko's **Raster Image Processor (RIP)**, based on the industry standard Adobe PDF Print Engine.

On top of Adobe PDF Print Engine, Imaging Engine includes Esko's renowned [color management](#), [screening](#), [dot gain compensation](#) and [output formats](#).

You can use Imaging Engine to both [proof and RIP](#) your files.

#### A RIP Integrated Seamlessly into Automation Engine

Imaging Engine is completely integrated into Automation Engine. This means that the Automation Engine Pilot is your single point of contact for using Imaging Engine (you do not need to launch or use any separate software).

You can run the [Imaging Engine tasks](#) on any PDF or Normalized PDF.

#### A Powerful Multi-Files Processing RIP

Taking advantage of Adobe PDF Print Engine's capabilities (64-bit, multi-threaded, multi-process architecture), Imaging Engine is powerful and highly scalable.

You can add more RAM and cores to your server hardware to process more files in parallel, and faster.



**Note:** The amount of parallel processing you can do also depends on your [license](#).

### 16.2. Using Imaging Engine for Proofing and RIP'ing

---

Files coming from a graphic designer often need a lot of prepress work before being printed. You can do this prepress work in Automation Engine for example.

After that, you can use Imaging Engine to both **proof** and **RIP** your files. When using the same solution for both proofing and RIP'ing, your proof will look much more like your final print than if you had used two different solutions.

#### Proofing with Imaging Engine

You can use Imaging Engine for both **content proofing** and **contract proofing**.

- You typically make a **content proof** to check whether the contents of your file (layout, text, barcodes...) are correct.
  - You can make a **physical** content proof with Imaging Engine's [Proof for Content Approval](#) task (this uses the Esko Proof Server and your proofer of choice).



- You can make a **digital** content proof with Imaging Engine's [Image to Content Proof \(RGB\)](#) task (this generates a high resolution preview file).
- You typically make a **contract proof** once you are satisfied with the content proof, to check that the colors of your proof also look as expected, and to show it to your customer as final proof before printing.

To ensure that your proof is as color accurate as possible, you [color manage](#) your job when making a contract proof.

You can do this with Imaging Engine's [Image to Unscreened Proof](#) task.



**Tip:**

If you also want to unquestionably **verify** the color accuracy of your proof against your customer's criteria when **contract proofing**, we recommend you use **Pack Proof** together with Imaging Engine.

See the [Pack Proof documentation](#) for more information.

### RIP'ing with Imaging Engine

After the proof is approved, the RIP is the last essential step to make sure your files are ready to send to your **output device**.

Imaging Engine can generate **screened** or **unscreened** files, depending on the device you want to use.

- You typically need **screened output** to send to a platesetter or filmsetter (for offset or flexo for example).

You can do this with Imaging Engine's [Image to Screened Separations](#) task.

- You typically need **unscreened output** to send to a device that will take care of the screening, or a device that doesn't need screened input (for gravure for example).

You can do this with Imaging Engine's [Image to Unscreened Separations](#) task.

See [Screened or Unscreened Output?](#) for more information.

You can also use Imaging Engine to generate [ink distribution data](#) for the files you want to send to your offset press (so that the press can automatically calculate the amount of ink needed for each separation of your RIP'ed files, without needing manual adjustments from the press operator).

You can do this with the [Calculate Ink Key Settings \(CIP3\)](#) task.

## 16.3. What Does Imaging Engine Do?

---

When **proofing** with Imaging Engine, you can:

- perform general file transformations to make sure the output is as expected (select the right page box, rotate/invert/mirror the file as needed, apply a distortion to pre-compensate for substrate distortion...),
- [color manage](#) objects in your file, or the whole file, so they look as expected on press (for contract proofing),
- [rasterize](#) the vector graphics to continuous tone bitmaps,
- output your file either [directly to your proofer](#), or to the [file format](#) needed for your proofing workflow or device (TIFF, PDF or JPEG).

When **RIP'ing** with Imaging Engine, you can:

- perform general file transformations to make sure the output is as expected,
- [rasterize](#) the vector graphics to continuous tone bitmaps,
- if needed, [screen](#) those bitmaps at the correct resolution for your output device and with the screening settings most applicable to your printing method,
- add [dot gain compensation](#) to compensate for plate and/or press dot gain,
- output your file to the [file format](#) needed for your imaging device (TIFF, LEN, LENX, or PDF).

**Note:**

Make sure you have done all other necessary prepress before sending your file(s) to Imaging Engine, either in your editor of choice or in Automation Engine.

For example if you are working with a file that has different versions or languages, and you need to merge one of the "language" separations with one of your base separations, you can do this using a PDF action list before sending your file to Imaging Engine.

You can make this PDF action list in ArtPro+, and use it in Automation Engine's **Apply PDF Action List** task. See the [Automation Engine - Merging Separations using PDF Action Lists](#) knowledge base article.

### 16.3.1. Color Management

Color management is making sure that colors are reproduced consistently at different stages of the printing process.

This consistency is especially important for specific "brand" colors, that have to look the same when printed on different substrates (cardboard, paper, plastic...).

#### How Are Colors Defined?

##### The Lab Color Space



Colors are generally defined by their position in the **Lab** color space, which is a 3D color model representing all colors visible to the average human eye (developed by the Commission Internationale de l'Eclairage).

It is based on three axes:

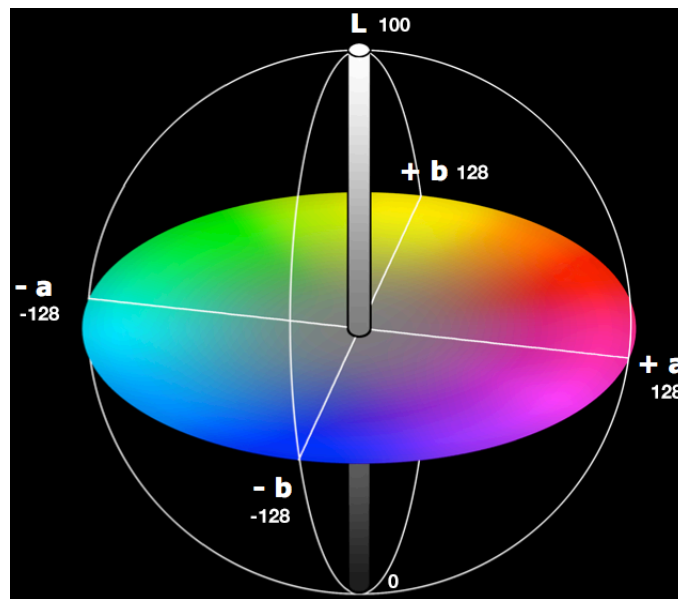
- the **L** axis (going from 0 to 100) defines the lightness of the color (a dark color has a low **L** value, a light color has a high one),
- the **a** axis (going from -128 to 128) defines how green or red a color is (a greenish color has a low **a** value, a reddish color has a high one),
- the **b** axis (going from -128 to 128) defines how blue or yellow a color is (a blueish color has a low **b** value, a yellowish color has a high one).



For example:

Color	Lab values
 light yellow	Lab (100, 0, 60)
 dark green	Lab (15, -128, 0)
 medium gray	Lab (50, 0, 0)

### Devices and Color Spaces

Different devices (a digital camera, computer monitor, proofer, press...) display or reproduce colors in different ways.

Colors in photographs are generally defined in the **RGB** color space (Red, Green, Blue), and monitors also use RGB to display colors.

Proofers and presses use **CMYK** (Cyan, Magenta, Yellow and Black -or "Key") for printing, and sometimes additional inks (for example Orange, Green and Blue, to be able to reproduce more colors, or one or two **spot colors** -generally Pantone inks- used in a particular file).

Files coming from a graphic designer may contain CMYK, spot colors and sometimes images in RGB.

### Devices' Profiles

Even within one color space, different devices can reproduce colors differently. For example, two CMYK proofers from different brands may print completely differently.

A device's **gamut** is the totality of the colors that device can reproduce (for example, the area shown in light green below).

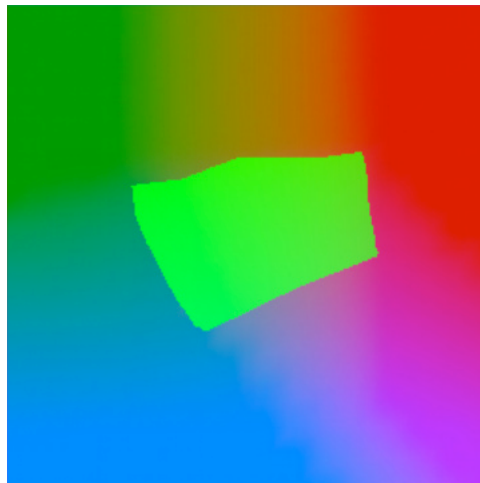

This is captured in the device's **profile**, which describes all the colors achieved when using different combinations of percentages from the base colors (RGB, CMYK, or CMYK + extra colors).

To create a profile for a press or proofer, you need to print and measure a profiling chart containing these combinations of percentages.

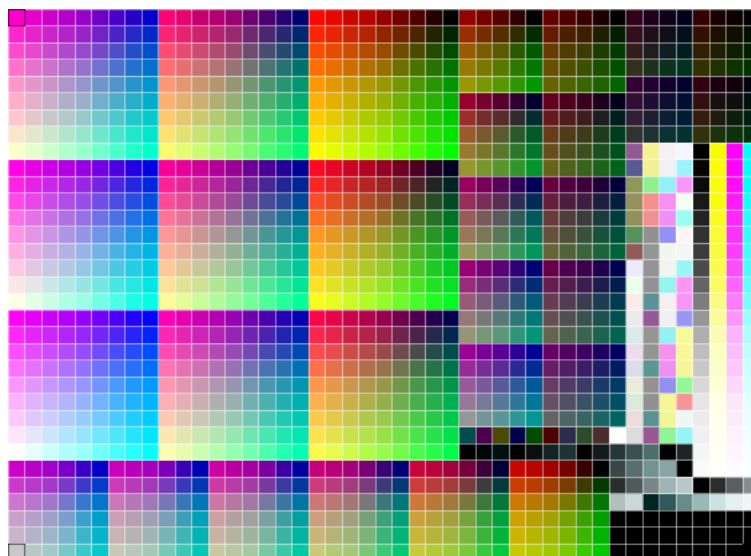

See the [Color Pilot documentation](#) for more information about creating profiles.

Imaging Engine support the following types of device profiles:

- Esko profiles, created in Color Pilot,
- ICC profiles, created in a third party application and written in a standard format.

### Using Profiles for Color Management

You need to have a profile for **each of your devices** to perform color management.



**Note:**

Proofers and presses' profiles need to reflect the device's exact printing characteristics (inks, substrate...).

So if for example you change your substrate, you need to make a new profile taking that substrate into account.

Once you have made the profiles, you can perform a **controlled conversion** of the colors between the different device profiles.

For example if you are printing a photograph, you need to convert its colors from the digital camera's RGB profile (the **source profile**) to the printer's CMYK profile (the **destination profile**).

This means that every color in the source profile is converted to the closest possible color that can be reproduced by the destination profile.

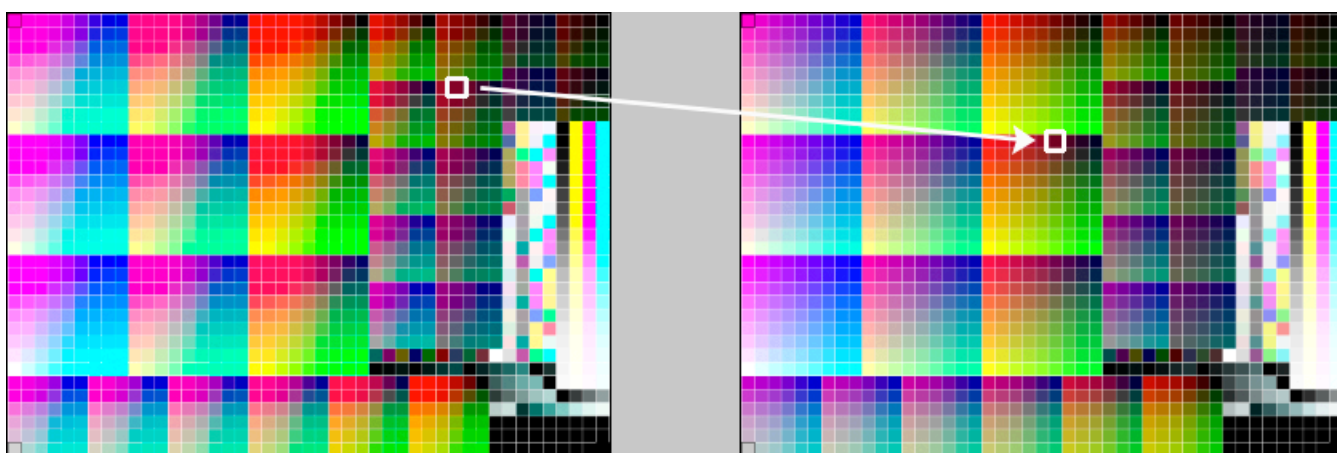

**Note:**

If you want to proof a file that will be printed on your press, you are trying to reproduce your **press'** colors on your **proofer**.

This means that the press profile is your **source** profile, and the proofer profile is your **destination** profile.

### Color Strategies

If you want to refine your color management, you can use **color strategies**.

A color strategy is a bundle of color management settings that contains at least the source and destination *profiles* of the devices you are using, and can contain other color management settings (*dot gain compensation curves*, settings like *rendering intent* for converting *out-of-gamut* spot colors and the background color, other settings for converting specific spot colors, etc).

Your company's color management expert can create these color strategies in Color Pilot, and you can simply select the one you need in your proofing ticket.

For more detailed information about Color Strategies, see the [Color Pilot documentation](#).

### Rendering Intents

A **Rendering Intent** is a part of your *color strategy* that handles the conversion of *out-of-gamut* spot colors and of the background color.

Each rendering intent does this in a different way, so you should choose the one that is more adapted to the way you are printing and the result you want to achieve:

- Use the **Relative Colorimetric** rendering intent if you don't want to simulate the source background (the point that has 0% of all inks in the source profile).

This will proof your file as if the proofer substrate was exactly the same as the substrate defined in your source profile.

For example: your press prints on cream colored card stock whereas your proofer prints on bright white paper, but you don't want to simulate the cream background on your proof.



With this rendering intent, colors from the source profile that cannot be reproduced by the proofer will be converted to the closest color(s) the proofer can reproduce.

In some cases several colors will be converted to the same color, which means that you can sometime lose some detail, especially in dark saturated areas and the dark parts of gradations.

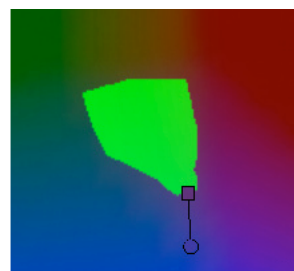
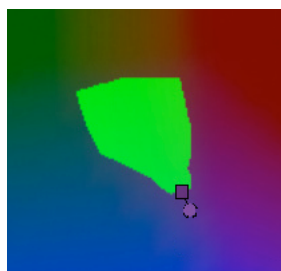



Note that typically the proofer profile has a bigger gamut than the press profile, so there are not many colors that the proofer cannot reproduce.

- Use the **Absolute Colorimetric** rendering intent if you want to simulate the source background to get as exact a color match as possible.

For example: you do want to simulate the cream colored card stock used on your press on your proofer substrate, to see how the final output will look like (this doesn't only affect the white but all the colors in your file).



As with the Relative Colorimetric rendering intent, colors from the source profile that cannot be reproduced by the proofer will be converted to the closest color(s) the proofer can reproduce, meaning you can sometime lose some detail, although there are typically not many press colors that a proofer cannot reproduce.

- Use the **Perceptual** rendering intent if you are not trying to get an exact color match but want the proof to look visually pleasing.

If there are colors from the source profile that cannot be reproduced by the proofer, this will shrink the source gamut to fit inside the gamut of the proofer, so that all colors are converted (even the colors already in the proofer's gamut), but the relationship between colors is kept.

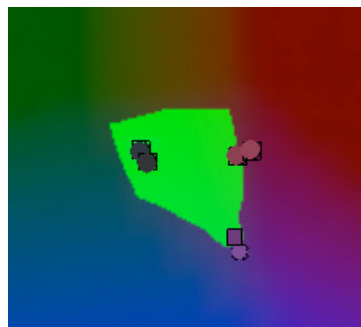

This means that colors won't be really accurate, but you won't lose detail in dark saturated areas or gradations.

This rendering intent is most commonly used in commercial printing (for newspapers, magazines, posters...).

- Use the **Saturation** rendering intent if you mostly want to make sure the colors on your proof are saturated enough.

Colors from the source profile that cannot be reproduced by the proofer will be mapped onto close saturated colors that are in the proofer's gamut.

This rendering intent is most commonly used for business presentations containing graphics, or cartoons/comics.



**Note:**

- If you are working with Esko source and destination profiles, you can use the **Absolute Colorimetric** or **Relative Colorimetric** rendering intent.
- If you are working with ICC source and destination profiles, you can use any rendering intent.

### The Color Management Database

All your [profiles](#), [color strategies](#) and inks are stored in a color management database (also called "CMS database").

You install this color management database when installing Automation Engine. You can install it on your Automation Engine server or on another server (the server you install your color management, [curves](#) and [screens](#) databases on is called the "resources server").

After this, the profiles, color strategies and inks in your color management database are automatically available in the [Imaging Engine tasks](#).



**Important:**

If you are using Imaging Engine [for proofing](#), you should also install Color Pilot when installing Imaging Engine.

This will enable you to create your own profiles, color strategies and inks, and to access [PantoneLIVE inks](#) (if you have a PantoneLIVE license).

### PantoneLIVE

PantoneLIVE® is a database of Pantone inks in the cloud. It contains information about how different tints of an ink look like, and how the ink will look like on different substrates.

Because it is in the cloud, the same color data is accessible to every actor of the packaging production, globally (while being protected by a login). This ensures that you get predictable and accurate color every step of the way, saving time and costs.

To use PantoneLIVE inks, you need Color Pilot and a PantoneLIVE license.

After logging on to the PantoneLIVE cloud from Color Pilot, you will be able to download PantoneLIVE ink books from the cloud, and use PantoneLIVE inks in your files.



Please see the [Color Pilot documentation](#) for more information about accessing PantoneLIVE ink books.

**Note:**

If you don't have a PantoneLIVE license, any PantoneLIVE ink in your files will be treated as an unregistered ink (an ink not present in your color database), and you will not be able to proof or RIP it accurately.

In this case you should ask the file's designer to replace the PantoneLIVE ink by an ink that is present in your color management database.

## 16.3.2. Rendering

### What is Rendering?

Files coming from a graphic designer may contain **vector graphics** or "linework" (especially for fonts or logos).

Vector graphics are highly scalable without any loss of quality (as they are not based on pixels but on mathematical formulas), but they are **not printable**.

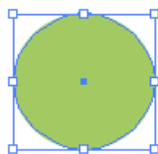

To be able to print those graphics, you need to **render** them on a **raster** (this is also called **rasterizing**). This raster is a rectangular grid composed of square pixels. You then get **bitmap images**, or "contones" (continuous tone images), made up of pixels.

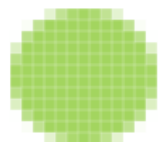

The raster has a certain width and height in pixels, and a certain **bit depth**. This is the range of colors that its pixels can have (for example 1-bit is monochrome, 8-bit is grayscale or a limited range of colors, 16-bit is a larger range of colors...).

Low-resolution bitmaps can look pixellated, but Imaging Engine generates high-resolution bitmaps.

In Imaging Engine, you can choose to:

- output your files as contones if you need [unscreened output](#) (you can do this with the [Image to Unscreened Separations](#) and the [Image to Unscreened Proof](#) tasks).
- screen those contones to get "halftones" if you need [screened output](#) (you can do this with the [Image to Screened Separations](#) task).

## Rendering Options

Depending on your input file type and the result you want, you can set several options in Imaging Engine to help you make sure your bitmap images look good on print:

- [Anti-Aliasing](#) on page 1188,
- [Resampling](#) on page 1188,
- [Identical One-Ups](#) on page 1190.

## Anti-Aliasing

You may sometimes experience issues with jagged edges, in text and along other slanted or curved edges. This happens more often at lower resolutions, and is due to the square pixels not being able to represent these edges finely enough.

In such cases, you can apply **Anti-aliasing**, to average the color of the edge pixels, and make these edges appear smoother.

In the example below, you can see the difference between output without anti-aliasing (on the left), and with anti-aliasing applied (on the right).

text text



**Attention:** Because anti-aliasing changes the output sampling to smooth the jagged edges, you cannot [resample](#) your images if you use anti-aliasing.

## Resampling

When rendering an input file with images, the images' pixels may not map exactly to output pixels if:

- the images' resolution is different from the output resolution you chose,
- scaling and rotation effects change the size and placement of the images' pixels.

This is especially problematic when the images' resolution is much lower than the output resolution, as this makes them look pixellated and/or fuzzy in the output. In such cases, you need to **resample** these images to be able to output them at the same resolution as the rest of the file.

You can choose between two resampling methods:

- Use the **Auto Resampling** method to upsample the images to an automatically calculated resolution (generally half or a third of the output resolution) before smoothing them.

When using this for unscreened output, images are a lot less pixellated and fuzzy.



For screened output, this method significantly reduces the risk of broken dots.

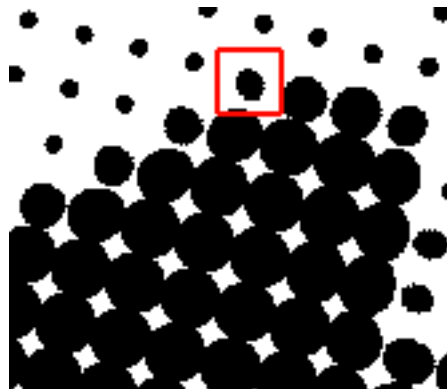

This method takes some time but gives images of a good quality, so it is recommended in most cases.

- Use the **Full Resampling** method to upsample the images to the full output resolution. This method is the slowest, but gives the highest quality images (not pixellated and only slightly fuzzy in unscreened output).



When using this for screened output, images have no risk of broken dots.

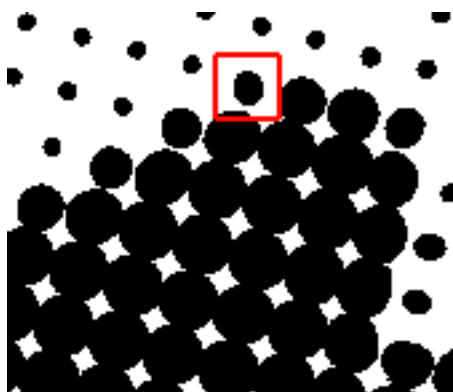

Use this if **Auto Resampling** doesn't give you the results you want.



**Attention:**

Resampling to full resolution can require significant amounts of memory when the output resolution is high (especially from 4000 dpi).

If you want to do this, we recommend that you have at least 8GB of RAM available for each worker (see the installation documentation).

**Identical One-Ups**

When working with Step and Repeat files, you sometimes want your one-ups to look exactly identical on print.

If you are printing with Gravure for example, small differences in your one-ups can lead to slightly different engraving. Since Gravure typically uses lower resolutions, this may be visible on print: fine details may be different between one-ups (in images or text, for example in Asian characters).

Below you can see a zoomed in area of two one-ups, and the pixel comparison of these one-ups (on the right) in the Bitmap Viewer.

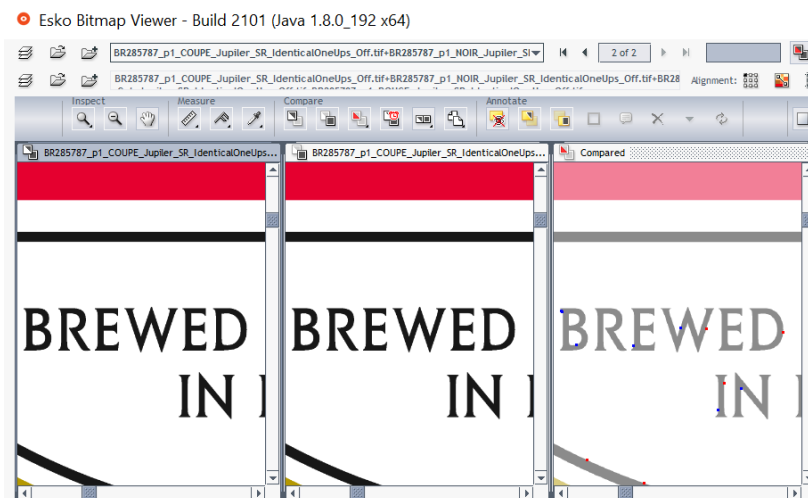

To counter this, you can choose to make your one-ups identical in Imaging Engine.

While *rendering* the file, Imagine Engine makes subtle shifts to the one-ups' positions on the pixel grid so that they are rendered identically. The shifts used are the smallest possible, to keep the output as predictable as possible.

This corrects (most of) the pixel differences between the one-ups.

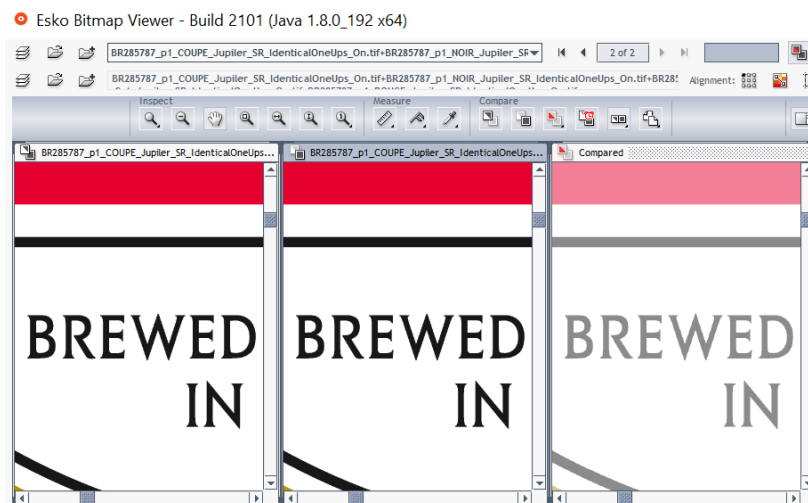

**Note:** In some cases, there can still be some very small pixel differences detectable in the Viewer, but these are too small to be visible on print.

You can choose to render identical one-ups for the following input file formats:

- *Plato* files (.pdf, .pla files and Normalized PDFs from Plato),

- Step and Repeat files in the Native PDF format (made by ArtPro+ or 3rd party software),
- Step and Repeat files in the ArtPro Classic file format (.ap or .art), if they were previously Normalized.

Apart from Step and Repeat files, you can also use this for input files using the **same external file several times** (for example, using the same image in several places), if:

- the input files are PDF+, and created in ArtPro+,
- each occurrence of the repeated external file has been added as "placed art" in ArtPro+,
- all occurrences of the repeated external file are identical (for example they all have the same size and orientation).

### Identical Screening for One-Ups

When setting **Identical One-Ups** for *screened output*, the screen is reset for each one-up, so that they are screened identically.

In some cases there can be minimal differences (as you can see below when zooming in a lot in the Viewer), but these are too small to be visible on print.



## 16.3.3. Screening

### What is Screening?

When printing an image on press, each ink (Cyan, Magenta, Yellow, Black and any additional ink) is laid out separately on the substrate, and the super-imposition gives the final colors.

At a high detail level, the press can either print ink or not print ink, so to create differences of color intensity within one ink, you use a small scale pattern of dots of varying size, called a screen.

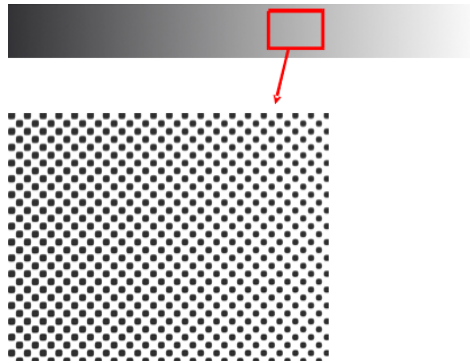

When viewed from a regular distance, this pattern looks like a lighter or darker shade of that color, depending on how big the dots are (what percentage of the area they cover).

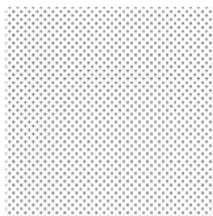

10%

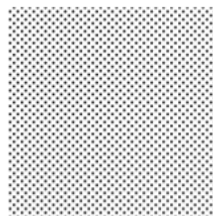

20%

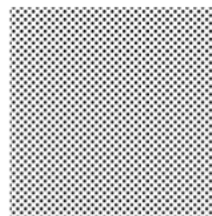

30%

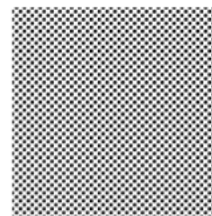

40%

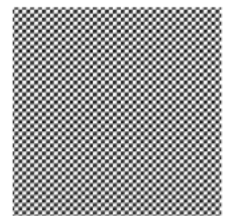

50%

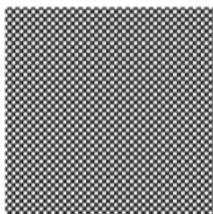

60%

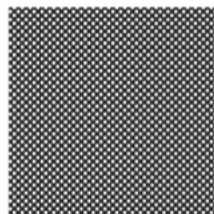

70%

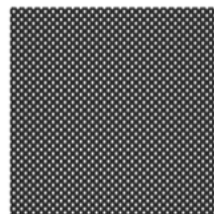

80%

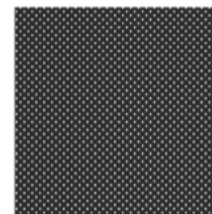

90%

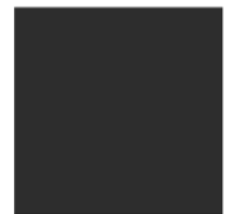

100%

### Screen Ruling

The screen can also be coarser or finer, so that you have to be more or less far away to see it as shades of a color. This depends on how many lines of dots can fit in a certain measurement. This is expressed in lines per inch (**lpi**), lines per centimeter (**lpcm**) or lines per millimeter (**lpmm**), and is called the **screen ruling**.



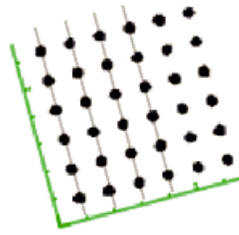

A low screen ruling as below left looks very coarse, and the quality improves as the screen ruling gets higher.



25 Lpi



45 Lpi



85 Lpi

### Screen Angles and Moiré

#### What is Moiré?

When placing the screens of two or more separations on top of each other, a visually disturbing effect called moiré can occur.

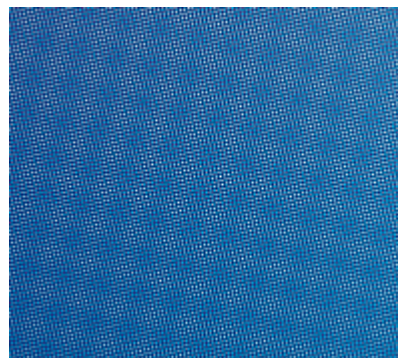

This is caused by the way the screen patterns are positioned relative to each other.

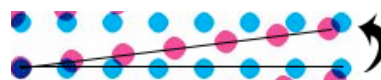



The most noticeable moiré patterns happen when the screens have a very small difference in angle between them:

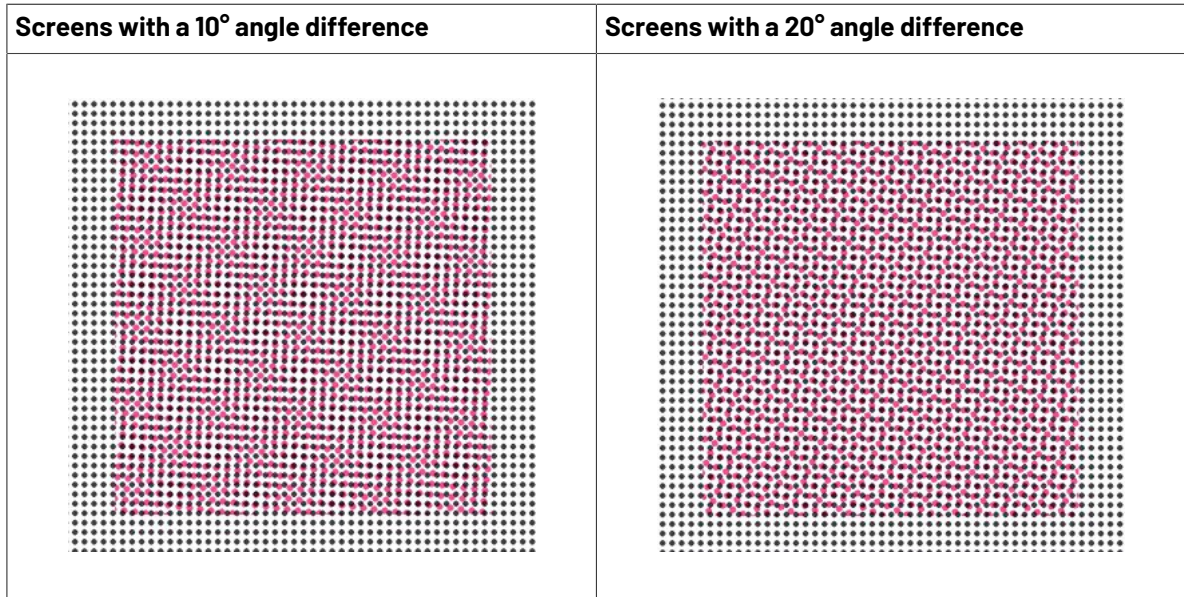

**Screen Angles**

To minimize moiré, the different separations' screens are placed at a sufficiently big angle from each other.

For CMYK, the most "visible" inks (Cyan, Magenta and Black) are placed at 30° intervals, and Yellow at a 15° interval.

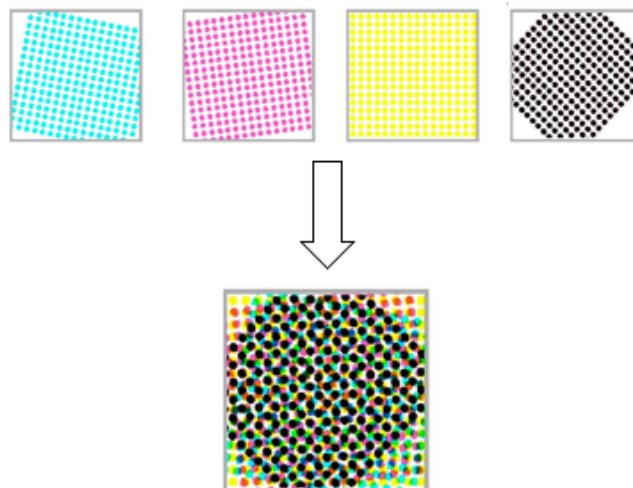

The exact screen angles used depend on the printing process:

- Basic offset angles are: Y at 0 degrees, C, M, and K at 15, 45 or 75 degrees depending on the application.

- Basic flexo angles are: Y at 7.5 degrees, C, M and K at 22.5, 52.5 or 82.5 degrees depending on the application (or Y at 82.5 degrees, C, M and K at 7.5, 37.5 or 67.5 degrees depending on the application).

Flexo angles are different from offset angles due to the anilox roll used in flexo presses (a cylinder which is engraved with millions of small cells that carry a thin film of ink which is deposited on the plate).

Putting the flexo screens on angles based on a 7.5° offset is needed to prevent moiré between the screen and the pattern of the inking cells of the anilox roll.

### Rosettes

When overlaying the screens of the different separations at *their respective screen angles*, you get a type of *moiré* which is much less visible and distracting at a normal viewing distance. This is called a rosette pattern.

A rosette pattern can be clear centered or dot centered.

- Clear centered rosettes (also called hole centered rosettes) (below left) are built up around a hole, and generally considered to be more stable.
- Dot centered rosettes (below right) are built up around a dot, and can give a more saturated result.

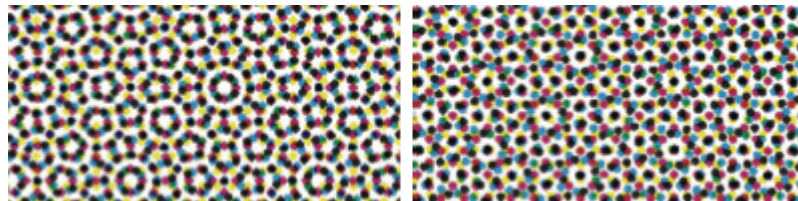

### Yellow Moiré

In four color printing, you may get "yellow moiré" or "4 color moiré" because the Yellow separation is only *at a 15° angle* from the Cyan.

This is typically less visible than *other types of moiré*, but may be a problem if:

- the yellow becomes contaminated by other inks on your press,
- you are printing lots of yellows, light greens and/or skin tones.

If you run into this problem, you need to adjust your yellow screen pattern so that it interferes less with other separations' screen patterns.

You can do this in Imaging Engine by automatically adjusting the yellow *screen ruling*.

### Screen Angle Range

Conventional screens can either work with a 90° or a 180° screen angle range.

#### Modulo 90 Screens

Modulo 90 screens are screens that only work with screen angles between 0° and 90°.

This is because when you rotate such a screen 90°, it looks exactly the same.

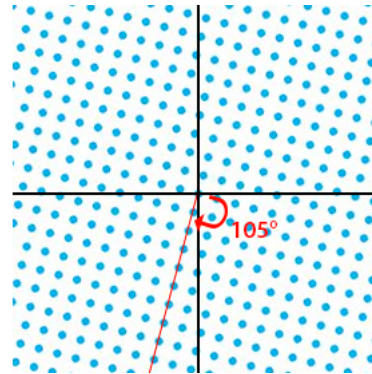
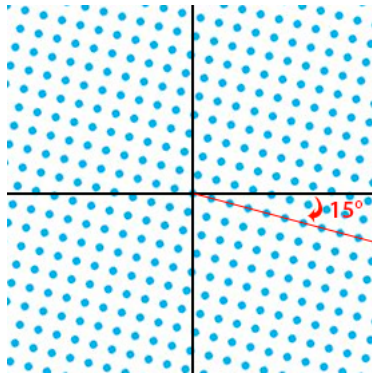

When working with such screens, you cannot place two different separations at angles that are  $90^\circ$  apart (if you did, the smallest registration error would cause severe *moiré*).

You need to place all separations between  $0^\circ$  and  $90^\circ$  (typically the most visible separations are placed  $30^\circ$  apart, and the least visible  $15^\circ$  from other separations).

Modulo  $90$  screens are usually screens that have a symmetrical dot shape, for example the *Circular dot*. However, some modulo  $90$  screens can have an asymmetrical dot shape, like the *Rugby dot*.

### Modulo 180 Screens

Modulo  $180$  screens are screens that work with screen angles between  $0^\circ$  and  $180^\circ$ .

Such screens look the same when rotated  $180^\circ$ , but not when rotated  $90^\circ$ .

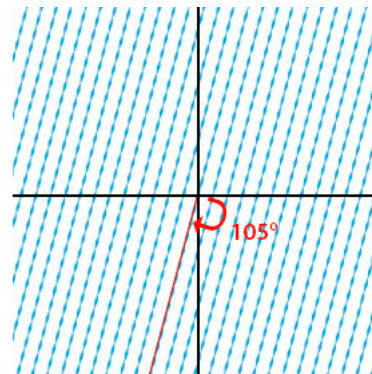
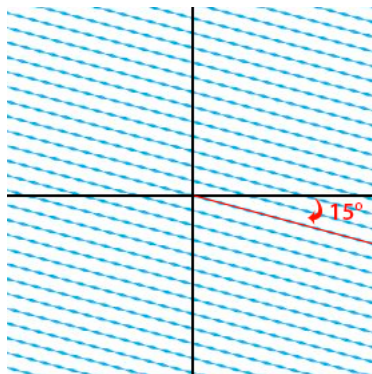

When working with such screens, you can place all separations between  $0^\circ$  and  $180^\circ$  (typically separations are placed  $60^\circ$  apart).

Modulo  $180$  screens are usually screens that have an asymmetrical dot shape, such as the *Eccentric* series of screens.



**Note:** You can check the characteristics of a screen in ScreenManager: in the screen details, a modulo  $90$  screen only lists angles from  $0^\circ$  to  $90^\circ$ , while a modulo  $180$  screen lists angles from  $0^\circ$  to  $180^\circ$ .

### Types of Screens Supported

Imaging Engine supports different types of screens:

- [screens with standard dot shapes](#),
- [screens with advanced dot shapes](#),
- [stochastic \(FM\) screens](#),
- [legacy screens](#) (screens that you have from an old version of FlexRip or Nexus RIP),
- [custom screens](#) (screens you have created in the Print Control Wizard, ScreenManager or HD Flexo).

Depending on your particular license, some of these screens will be included in your Imaging Engine, and others can be purchased as an option.

Please check the sales material of your product to know what is included.

Screens have a short name and a long name. For example **R** -> **Round Fogra** (**R** being the short name and **Round Fogra** the long name). When selecting a screen, they are listed alphabetically by short name.



**Note:**

Imaging Engine's halftone phase origin (the point where it starts screening the input file) is the top left corner.

This is the same origin point as FlexRip and Nexus RIP, so you should be able to re-run old jobs and get the same alignment (you may notice 1 pixel difference with old Nexus jobs).

**Screens with Standard Dot Shapes**

Depending on your license, your Imaging Engine product may include the following screens:

**Circular (Euclidean) (short name: C)**

This screen uses circular dots, that grow continuously circular until 100%.

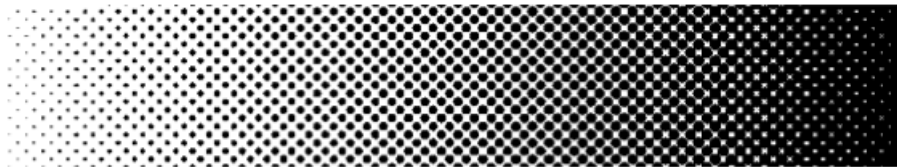

The circular dot is typically used for **flexography** and **letterpress**.

This dot gives good results in many situations. However in some printing conditions the holes in the shadows can fill in, which can result in unstable or high dot gain, and cause a loss in tonal range.

In this case consider using the Round Fogra dot instead.

**Double Circular (short name: F)**

This screen has circular dots in the highlights and mid-tones, and circular holes in the shadows.

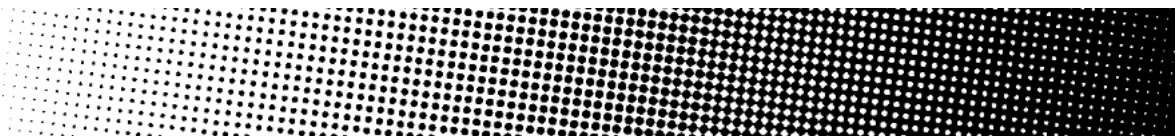

Note that this screen can cause irregular ink bridging ("bridges" between dots) around the mid-tones, which can give unstable dot gain in that tonal range.

In this case use the Round Fogra dot instead.

**Paragon Euclidean (short name: PAREUC)**

Paragon screens are designed for **offset** and **flexo** environments, to eliminate rosette drift and suppress red and green patterns.



This is a Paragon screen with a round dot in the highlights, a checkerboard pattern in the 50% region, and a negative round dot in the shadows.

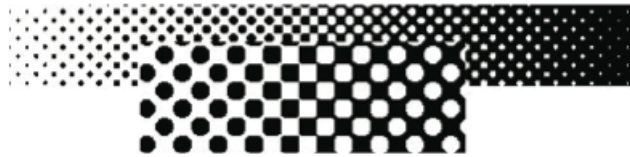

**Round Fogra (short name: R)**

This screen uses the Round Fogra dot, that closely resembles the elliptical and circular dots, and can be used the same way. It is also a better alternative for square dots.

It goes from a round dot to a round hole, with a square/diamond shape in the mid-tones.



As with elliptical dots, the touching of the dots at the four corners at 50% (leading to a 50% intensity jump) is avoided by using a more elongated dot shape so that the dots first touch around 45% forming a chain and touching for the second time around 55%. This causes less artefacts and less dot gain when printing.

The Round Fogra dot can be used for virtually all printing processes. It is very popular for **offset printing**, but it can also be used for **flexography, letterpress, silk screen printing** and for making films for **offset-helio conversion**. Only chemical etching gravure cannot be done with this dot shape.

**Screens with Advanced Dot Shapes**

Depending on your license, your Imaging Engine product may include screens with advanced dot shapes.

**Rugby (short name: D)**

This screen has a special dot shape and is used for **screen printing**. Rugby dots are shaped like a rugby ball, or a diamond with round edges, which dramatically reduces the interference of the dots with the mesh structure of the silk screen.



The dots touch around 35% to form chains. At 65%, a negative dot with rugby shape appears. This dot shape is fully symmetrical.

**Elliptical (short name: E)**

This screen uses a more elliptical version of the [Round Fogra](#) dots.



For these dots, the first touching point is around 35%. Between 35% and 65%, a chain is formed with the same orientations as for the Round Fogra dots.

**Helio (short name: H)**

Helio dots continuously grow square, even above 50%, forming "helio walls".

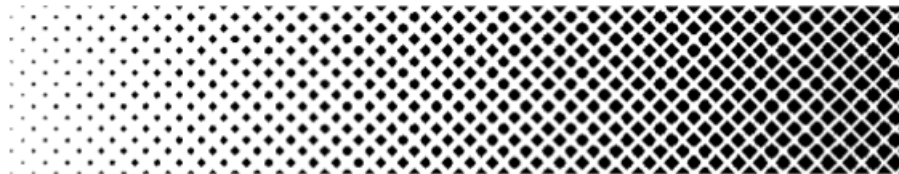

This dot is needed for the **classic gravure etching** processes only. The dot shape is highly optimized for both contone reproduction and linework areas.

**Convex helio** dots are the standard helio dots. The dot is as square as possible.

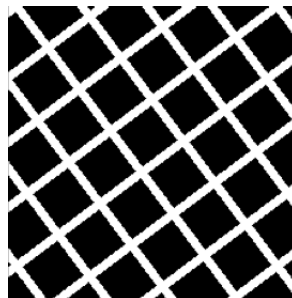

However in some circumstances the etching process smoothes out the square shape of the dots, which can cause the helio walls to break during printing (especially at the highest dot percentages), resulting in bad print quality.

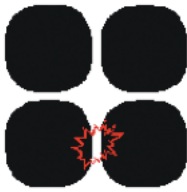
On film	On plate
	

In this case, you should use concave helio dots instead:



**Helio Concave (short name: G)**

**Concave helio** dots are designed to avoid the helio walls breaking that sometimes happen with standard **helio** dots.

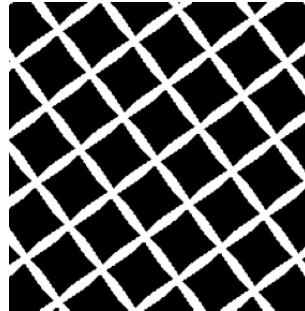
In the concave helio screens, the square-shaped screen dots are replaced by more pillow-shaped dots.



When etching the cylinder, the sharp ends are rounded off and the final result is closer to a square than the result of the standard helio dot.

On film	On plate
	

This dot shape will be useable up to slightly higher screen levels than the standard helio dot.

**Line (short name: L)**

This screen use lines instead of dots.



The advantages of using line screens are:

- there is no tonal jump because the lines never touch,
- the rosette patterns disappear completely, which gives the illusion of a higher ruling.

**Paragon Diamond35 (short name: PARDIA35)**

Paragon screens are designed for **offset** and **flexo** environments, to eliminate rosette drift and suppress red and green patterns.

Paragon Diamond35 is a screen with diamond shaped dots.



**Paragon Elliptical35 (short name: PARELL35)**

This is a Paragon screen with elliptical dots.



**Square (short name: S)**

This screen uses square dots in the highlights, forms a checkerboard at 50% and has square holes in the shadows.



At 50%, the tonal jump can be very noticeable, especially when the printing process causes the holes to fill (for example in Flexo), which results in a large dot gain. If the tonal jump is too obvious, use Round Fogra or elliptical dots instead.

**Eccentric 0 (short name: X0)**

Eccentric dots are a series of more or less elongated dots, X0 being the most elongated (the furthest from a round shape). A screen with X0 dots is close to forming lines.



Because of the more or less elongated shape of the dots, different eccentric dots have different touching points. The dots form a chain between the two touching points.

Eccentric 0 has a first touching point at 5% and a second touching point at 95%.





**Note:**

Eccentric dots have specific advantages for the **flexo** printing process:

- The flexo process is characterized by a high dot gain. Eccentric dots tend to lower this dot gain, as well as the tonal jumps caused by dot gain.
- The more eccentric the dot is (X0 and X1 dots), the less noticeable rosette patterns it generates. The difference in rosette patterns between eccentric dots and conventional round or circular dots is more striking in flexo than in offset or gravure, due to the lower rulings used in flexo.

**Eccentric 1 (short name: X1)**

Eccentric 1 dots are slightly less elongated than X0 dots.



Eccentric 1 has a first touching point at 10% and a second touching point at 90%.

**Eccentric 2 (short name: X2)**

Eccentric 2 dots are less elongated again.



Eccentric 2 has a first touching point at 20% and a second touching point at 80%.

**Eccentric 3 (short name: X3)**

Eccentric 3 dots are only slightly elongated.



Eccentric 3 has a first touching point at 30% and a second touching point at 70%.

**Eccentric 4 (short name: X4)**

Eccentric 4 dots are the least elongated of the eccentric dots. They are close to [Round Fogra](#) dots.

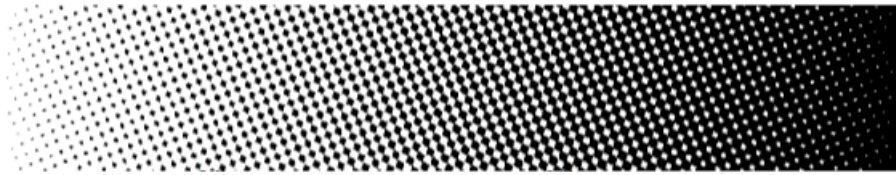

Eccentric 4 has a first touching point at 40% and a second touching point at 60%. At 50% the dots form a checkerboard.

**Stochastic (FM) Screens**

In "stochastic" (or Frequency Modulated) screens, dots are not placed on a regular grid pattern like in conventional (Amplitude Modulated) screens.

In a conventional screen, the dot size grows with the intensity (you have bigger dots at 50% than at 25%). In a stochastic screen, the dot size stays the same, but you get more dots per area as the intensity increases.

The advantages of stochastic screens are:

- sharper images,
- the full elimination of disturbing rosette patterns,
- no color shift caused by small registration errors (those errors are less visible than the same errors with conventional screens, which can reduce press preparation time),
- the possibility to combine more than 4 separations without *moiré*.

**FM (short name: FM)**

The FM screen is a first order stochastic screen (dots have the same size all over the density range), that uses square dots.



Each FM dot size corresponds to a specific set of rulings, for different output resolutions. You can find more information in the [Imaging Engine Screen Rulings](#) look-up table.

**Monet (short name: M)**

The Monet screen also uses dots of the same size all over the density range, but unlike the FM screen, it can have square and/or rectangular dots. It is optimized for **offset** printing.

In many cases, it can also be used in combination with a [Rugby dot](#) for **silk screen printing**.

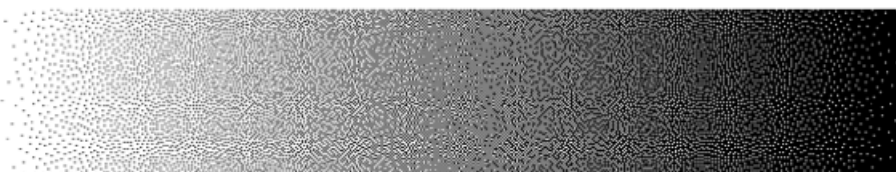

If you experience high dot gain when using a Monet screen, we recommend you switch to an Organic screen.

Each Monet/Monet for Flexo dot size corresponds to a specific set of rulings, for different output resolutions. You can find more information in the [Imaging Engine Screen Rulings](#) look-up table.

**Monet for Flexo (short name: MF)**

This screen is based on the Monet screen.

The Monet for Flexo screen has holes in the shadows that are bigger than the dots in the highlights, so they don't fill up as much with dot gain (not increasing the shadows' darkness too much).

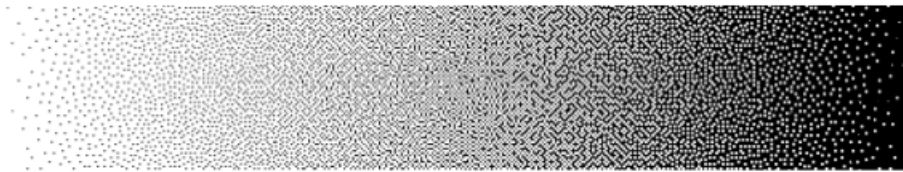

This is especially beneficial for printing processes with high dot gain such as **flexo**.

Each Monet/Monet for Flexo dot size corresponds to a specific set of rulings, for different output resolutions. You can find more information in the [Imaging Engine Screen Rulings](#) look-up table.

**(Older) Monet for Flexo (short name: MFOLD)**

The **Monet for Flexo** screen used in FlexRip and versions of Imaging Engine up to 16.0.2 has been renamed to **Monet for Flexo - with perimeter info for FlexRip (short name: MFOLD)** from Imaging Engine 16.1.

- If using this screen gave you satisfactory results, you can continue using it as before.
- If you experienced problems with the grey levels not being linear enough throughout the tonal range (such as the mid-tones being too light), you can use the new Monet for Flexo (short name: MF) screen instead (available from Imaging Engine 16.1).

**Organic (short name: O)**

Unlike first order stochastic screens like FM, Monet or Monet for Flexo, where the single dots are left on their own, the organic dots are combined in clusters, forming organic-like random structures. This reduces the dot gain around the mid-tones.

However, Organic screens can generate noise in images, giving a grainy appearance. If you experience this problem, we recommend you switch to a Monet screen.

The Organic screen is optimized for **offset** printing.



**Legacy Screens**

If you have some screens that you got with an old version of FlexRip or Nexus RIP, they will still be available in Imaging Engine.



**Note:**

Those are pre-calculated screens that were created for specific printing environments or to solve specific problems. They can only perfectly match certain sets of conditions.

Today, you can get the same effects, fine-tuned for your particular printing conditions, by creating [custom screens](#) in HD Flexo and/or ScreenManager.

See the HD Flexo and/or ScreenManager documentation for more information.

**Conventional (AM) Screens**

**TwinBeam (short name: CD0)**

The TwinBeam screen was developed for the CDI. It uses round dots that are exposed by two laser beams.

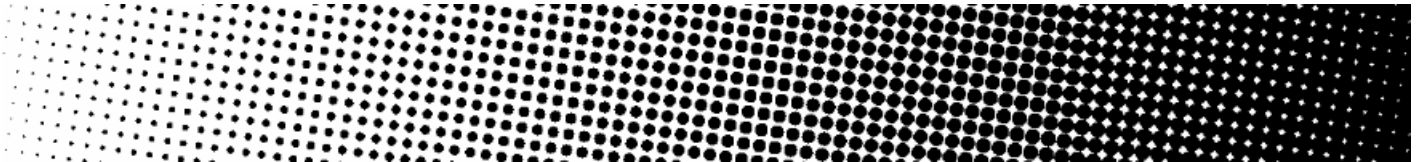

**CDI MultiBeam Optimized (short name: CD1)**

The CDI MultiBeam Optimized screen was also developed for the CDI, as an improvement to the TwinBeam screen. It uses round dots that are exposed by several laser beams.

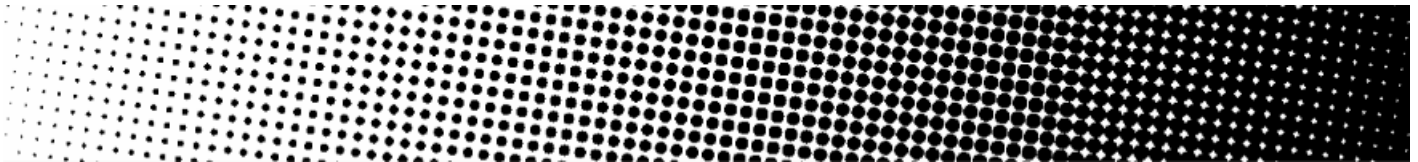

**Endless (short name: C0)**

This screen was used in combination with cylindrical sleeves on the CDI, to make several copies of a job print continuously on the substrate, without broken dots at the edges of each job.

For best results, we recommend you use the [seamless screening](#) functionality to create a custom seamless screen instead of using the Endless dot.

This screen uses a circular dot shape.

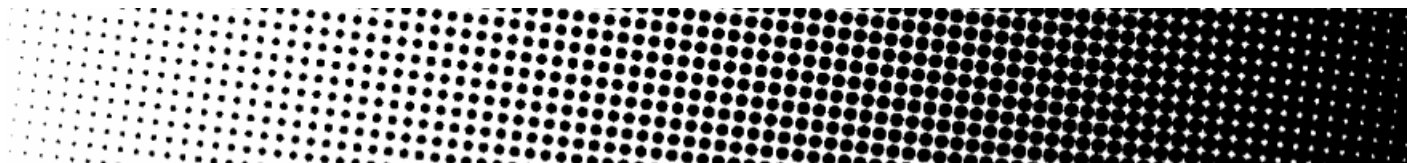

**Groovy (short names: GY1 to GY5)**

Groovy screens put a line pattern in the dark areas of the screen only. The lighter areas have a [Double Circular](#) dot pattern.



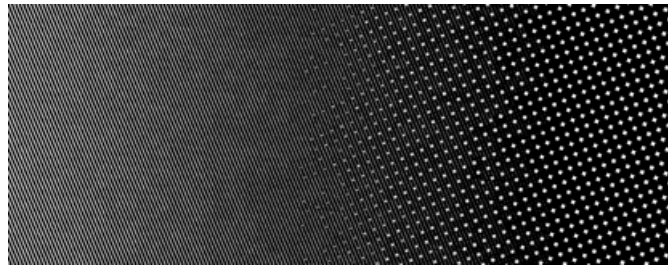

The transition between the normal screen pattern and the line pattern is smooth, leading to a smooth gradation on print between the lower density (non-groovy) and higher density areas (groovy).

They improve solid rendering in **flexo** printing (the lines help even out the ink distribution) and have their best performance on foils. Performance on other substrates (paper, metal) is heavily dependent on the printing circumstances.

You can choose between different groovy screens:

Long name	Short name	Pattern angle	Pattern ruling	Transition start	Maximum pattern percentage	Pattern
Groovy1	GVY1	Close to 45 degrees	3 times the original ruling	95%	45%	Lines
Groovy2	GVY2	Close to 45 degrees	3 times the original ruling	90%	45%	Lines
Groovy3	GVY3	Close to 45 degrees	4 times the original ruling	95%	45%	Lines
Groovy4	GVY4	Close to 45 degrees	4 times the original ruling	90%	45%	Lines
Groovy5	GVY5	Close to 45 degrees	3 times the original ruling	93%	45%	Eccentric1

### Transitional (AM/FM) Screens

#### Circular Samba (short name: CS)

Samba screens are transitional screens, that were designed to solve problems in the highlights in **flexo**.

They have a *stochastic* part in highlights and shadows, a conventional part in the mid-tones and the transition between both contains a pattern that is gradually going from stochastic to conventional over a large number of intermediate patterns.

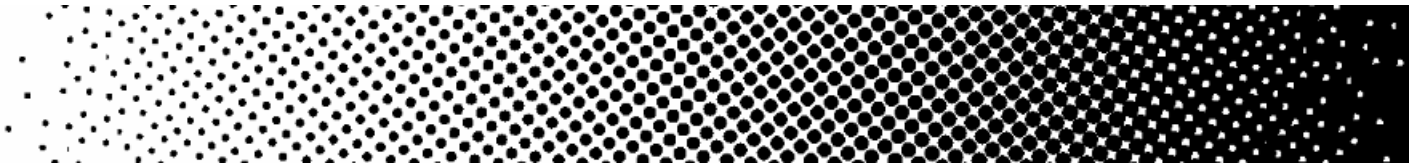

**SambaFlex (short names: CS4 to CS45)**

Like Samba screens (which they are based on), SambaFlex screens are transitional screens, going from stochastic to conventional and back.

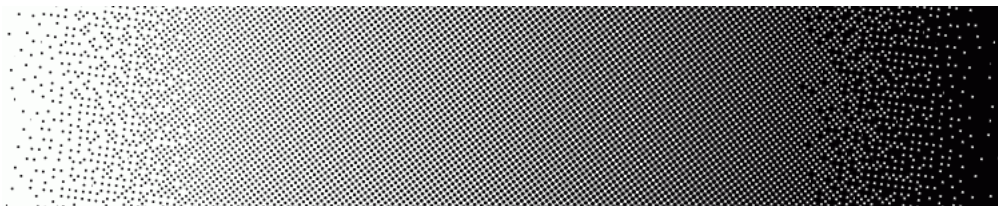

SambaFlex screens support seven different minimum dot sizes, for every imagesetter resolution. These sizes cover a very broad range, from hardly visible dots until dots so big that they can only be used for artistic effects.

- Screens with a small minimum dot size (like **CS4**) have almost unnoticeable stochastic effects.
- Screens with a bigger minimum dot size (like **CS45**) have a coarser stochastic pattern, and less dots in the highlights. The transition point in the highlights shifts up to higher dot percentages.

**SambaFlex Highlight (short names: CS4H to CS45H)**

These screens are based on the SambaFlex screens, and only have a stochastic part in the highlights. In the shadows, they stop at the darkest point, whether it is 100% or not (for these screens it is usually 95%).

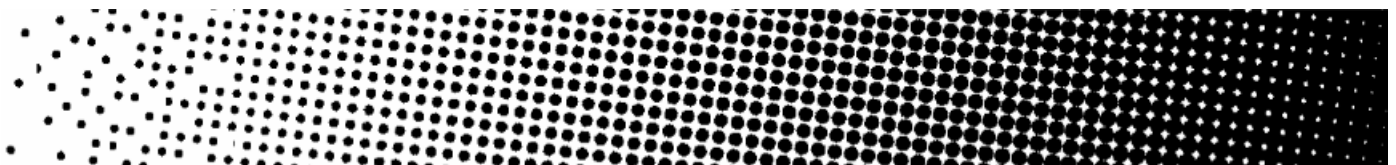

**Custom Screens**

In Imaging Engine, you can also use any custom screen you created in the **Print Control Wizard**, **HD Flexo** or **ScreenManager** application. You will recognize those custom screens because:

- Screens created with the **Print Control Wizard** have a short name beginning with **CRS** (**CRS01**, **CRS02**...).
- **CRS** (or "Crystal") screens are developed exclusively for use with the *CDI Crystal imager series* and the *XPS Crystal exposure unit series*.
- See *Crystal Screens* on page 1209 for more information.
- You can find more information about creating a screen with the Print Control Wizard in the *Print Control Wizard documentation*.
- Screens created in **HD Flexo** have a short name beginning with **HD** (**HD01**, **HD02**...).

For more information about creating a screen with HD Flexo, please see the HD Flexo documentation (available from within your application).

- Screens created in **ScreenManager** have a short name beginning with **SCR (SCR01, SCR02...)**.

For more information about creating a screen with ScreenManager, please see the ScreenManager documentation (available from within your application).

### Crystal Screens

Crystal screens are Esko's latest screening technology, developed exclusively for use with the [CDI Crystal imager series](#) and the [XPS Crystal exposure unit series](#), for a high quality flexo printing workflow.

You can create Crystal screens using the [Print Control Wizard](#), that will guide you in creating custom screens and curves for your specific printing setup, to ensure better quality control.

For more information about creating a custom Crystal screen, see the [Print Control Wizard documentation](#).

### Screen Characteristics

Crystal screens use multiple Esko screening technologies:

- Pixel+ technology, where each dot is made of individual pixels, that are "boosted" on the CDI to make printable dots,



- a transition from solid dots in the highlights to Pixel+ dots in the rest of the tonal range (for the Crystal C variant of the Crystal screens),

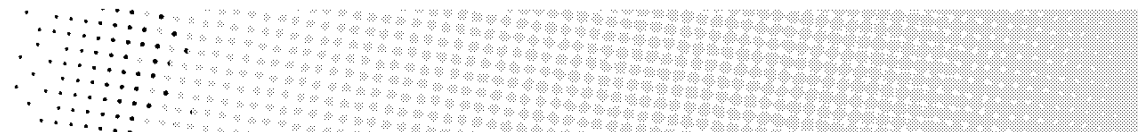

- [FM screening](#) in the highlights (used in your custom screen when it benefits your specific printing setup),
- [support dots](#) at single or double ruling (used in your custom screen when it benefits your specific printing setup).

When using Crystal screens, you don't need to use object-based screening (different screens for individual objects in your file), as they give good results in all areas:

- They provide a smooth transition from the solids into the shadows and mid-tones, with reduced dot bridging.

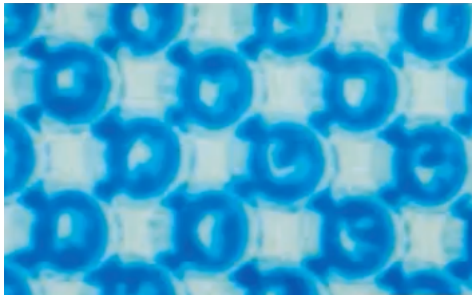

dot bridging with a circular dot

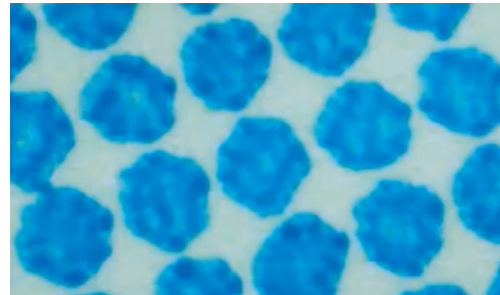

no dot bridging with a crystal screen

- They produce stable highlights that fade out to zero more smoothly than with other screening technologies.

### The Screens Database

All your *screens* are stored in a screens database.

You install this screens database when installing Automation Engine. You can install it on your Automation Engine server or on another server (the server you install your screens, *curves* and *color management* databases on is called the "resources server").

After this, the screens in your screens database are automatically available in the *Imaging Engine tasks*.

### Seamless Screening

#### What is Seamless Screening?

You can use seamless screening if you want to print several copies of a job continuously on your substrate (typically using flexo sleeves, that you image using a *CDI* or other CTP device).

Seamless screening makes sure the screening is continuous between jobs in the horizontal direction, so that there are no broken dots at the edges of each job (that could cause a visible join or *moiré* effects).





**How Does it Work?**

Imaging Engine starts from the requested screening parameters (resolution, dot shape, screen angle and ruling), and if necessary modifies them slightly to ensure there are no broken dots at the horizontal seam between jobs.

This modification can be a slight scaling and/or rotation, and gives a result which is very close to the requested screening parameters. Depending on your file and parameters, there may be:

- a ruling difference of maximum 2 lpi,
- an angle difference of maximum 1 degree,
- in some cases, a slight horizontal or vertical shift near the seam,

This shift is typically no bigger than 1 pixel, except when using a high resolution with a low ruling (like 4000 ppi and 80 lpi, or 2000 ppi and 40 lpi), where it can be slightly more.

- a rosette shift over a distance of at least 1 meter.

A rosette shift is when the *rosette pattern* gradually shifts from clear centered to dot centered (or vice-versa), over a certain distance.

Since seamless screening makes sure that the rosette pattern is identical on both sides of the seam, the most variation occurs in the middle of the file.

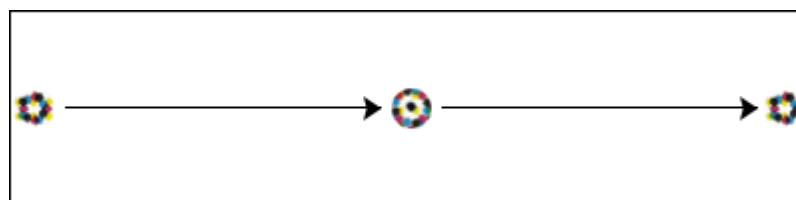

In most cases (for example when using a 400 mm wide CDI sleeve), this will not be noticeable.

For 2 meter wide files, the rosette pattern will be different in the middle of the file (for example, it will go from clear centered on one edge, to dot centered in the middle, and back to clear centered on the other edge, as in the example above).



**Note:** You can find information about any modification made to your screening parameters to make your screen seamless in the Imaging Engine task's log file.

### What Screens Can You Use it With?

You can use seamless screening with any dot shape/screen except:

- stochastic screens,
- Groovy screens,
- Samba or SambaFlex screens,
- Paragon or other legacy Artwork Systems screens.



**Tip:**

If you need a seamless Samba screen, do the following:

1. In ScreenManager, create a custom screen that has the same properties as the Samba screen:
  - with highlight effects enabled,
  - with the transition method set to "Traditional PerfectHighlight",
  - with the same transition point as the Samba screen (for example, to replace the Samba screen "CS25", set the transition point to 25).
2. Make that custom screen seamless.
3. Use that custom screen in Imaging Engine, with the seamless screening option.

See the ScreenManager documentation for more information.

The following screens cannot completely be made seamless:

- AutoBlend screens (that use stochastic screening in the highlights and conventional screening in the rest of the range): the stochastic part of the screen will not be seamless.
- HD Flexo screens with advanced screening effects (for example a highlight effect or surface screening): the dot, screen ruling and angle will be seamless, but not the advanced screening effects. For example:

If your screen has a highlight effect that removes some dots to decrease tone in the highlights, the same dots will not be removed on both sides of the seam.

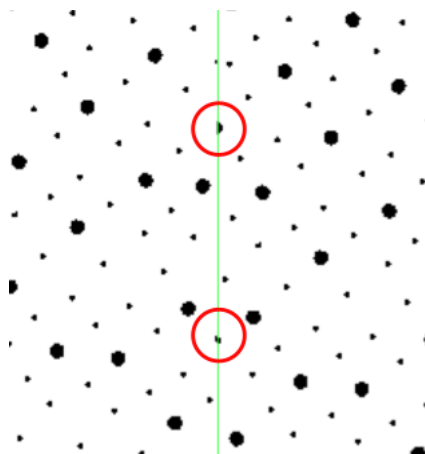

If your screen has microcells that perforate dots and solids to improve ink lay down, the microcell pattern will not repeat continuously near the seam.

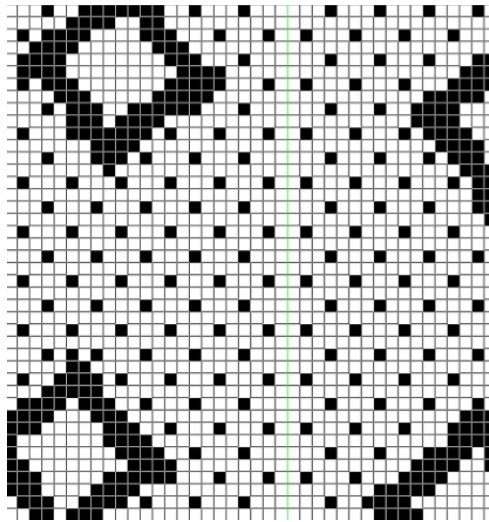

### Screened or Unscreened Output?

When RIP'ing your files with Imaging Engine, you can produce either screened or unscreened output.

- You typically need **screened output** to send to a platesetter or filmsetter (for offset or flexo for example).

Run the [Image to Screened Separations task](#) on your input file to produce screened output (a screened file per separation).

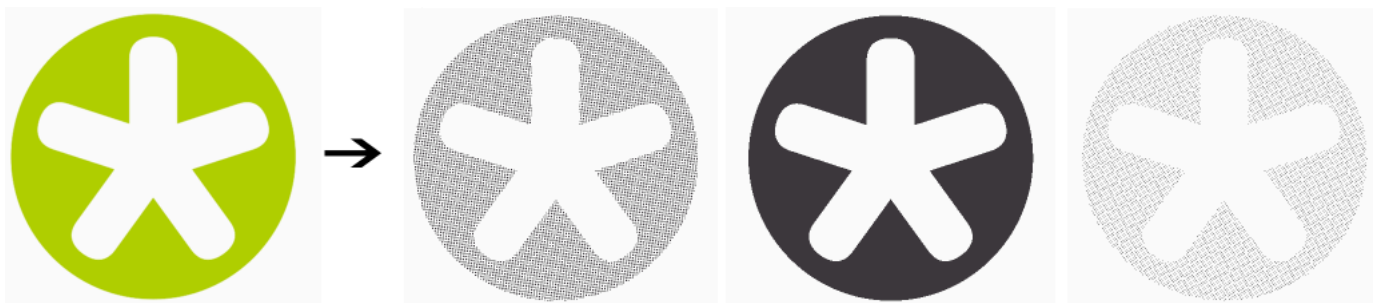

- You typically need **unscreened output** to send to a device that will take care of the screening, or a device that doesn't need screened input (for gravure for example).

Run the [Image to Unscreened Separations task](#) on your input file to produce unscreened output (an unscreened file per separation).



## Quality Control for Screened Output

### Inspecting Screened Files with the Bitmap Viewer

Once you have generated screened files with Imaging Engine, you can inspect them with the [Bitmap Viewer](#).

The Bitmap Viewer is a powerful quality control tool that will help you verify the content and printability of your screened files before you make plates from them.

It is a separate application, that you should have [installed](#) as part of your Imaging Engine installation.

#### Using the Bitmap Viewer

You can open the Bitmap Viewer from:

- your desktop (using its shortcut icon ) ,
- your output file in Automation Engine (as explained below).

The first time you want to open a file in the Bitmap Viewer from the Automation Engine Pilot, do the following:

1. Right-click the file to open and select **Open With** then **Other...**
2. In the **Select Application** dialog that opens, click **Register...**
3. In the **Register** dialog that opens, click **Browse...** and browse to the executable of your Bitmap Viewer application.

If you installed it in the location proposed by default, the path should look like either:

- `C:\Esko\BitmapViewer_x64\BitmapViewer.exe` if you have installed the 64-bit version of the application,
- `C:\Program Files (x86)\BitmapViewer\BitmapViewer.exe` if you have installed the 32-bit version of the application.

4. Click **OK**.
5. Click **Open** in the **Select Application** dialog.

The next time you want to use the Bitmap Viewer, you can just right-click your file, select **Open With**, and select **BitmapViewer**.

### Inspecting Screens with Advanced Screening Effects

**What is an Advanced Screening Effect?**

If you are using HD Flexo screens or *custom screens* created in ScreenManager, those screens may contain advanced screening effects to help improve your printing quality.

Advanced screening effects modify specific parts of your screen, to improve how the plate interacts with the ink and paper, and achieve a better printed result in those areas.

Typically they are applied in the highlights (**highlight effects**), or the shadows (**surface screening effects**).

For example:

- **PerfectHighlights** screens have very small "support dots" in the highlights, that are not printable but improve the highlights' stability.

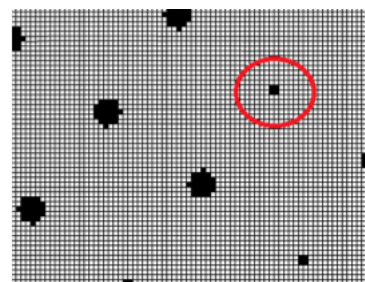
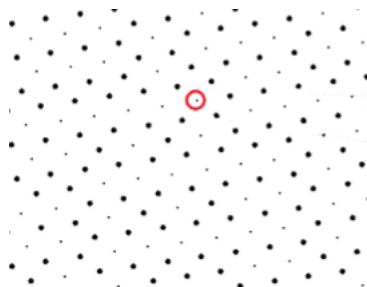

- **Groovy** screens have grooves in the solids (or in the dots and solids), to improve ink lay-down and print more evenly (the grooves will fill up when printing).

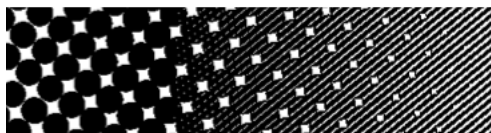

This helps prevent "pin holes" created by too much ink in the solids.

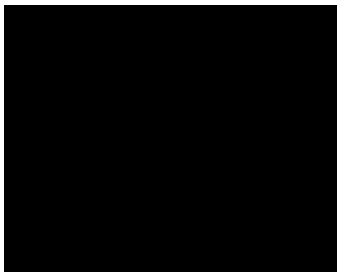
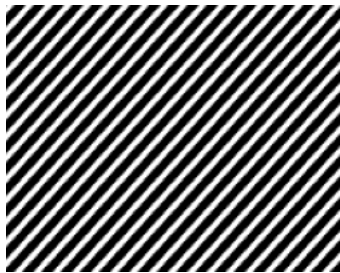
	Plain solid	Solid with surface screening effect
Digital file		

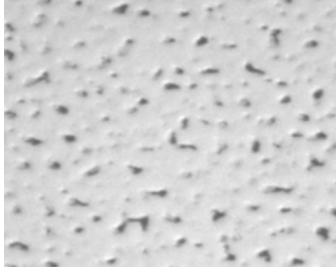
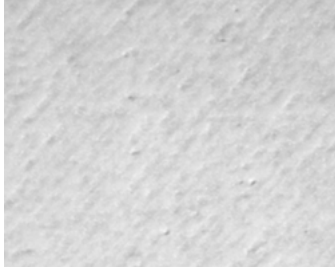
	Plain solid	Solid with surface screening effect
Printed result (with white ink)		

- **Cell centered / Platecell** screens have holes in the dots that grow as the dots grow (the dots are "cell centered"), while the solids are perforated by a uniform pattern (the "platecell" pattern). This also improves ink lay-down.

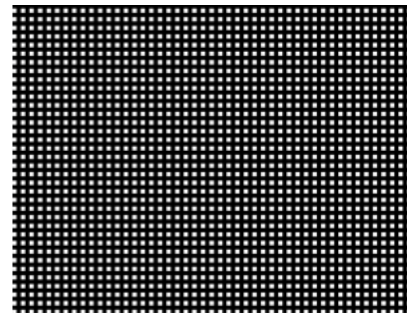
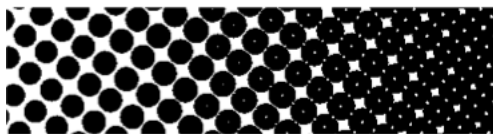

- **Microcell** screens have a specific type of holes ("microcell" holes) in the dots and solids. This also improves ink lay-down.

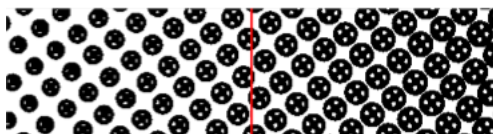

- **P+ Microcell** screens use a pattern composed of single pixels to create holes in the dots and solids. These screens are used on certain CDI devices, for example for Full HD Flexo.



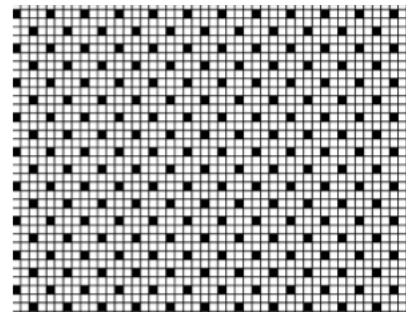
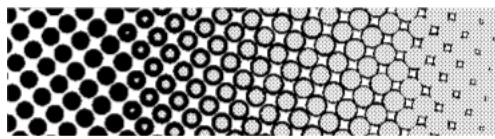

- **Concentric** screens have ring-shaped holes in the dots, to print with a thinner ink layer and improve the color of the printed result.

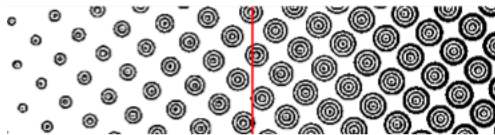

For more information about advanced screening effects and how to use them, please see the HD Flexo and/or ScreenManager documentation.

**Performing Quality Control on Screens with Advanced Screening Effects**

While screening effects improve print quality, screens with those effects do not look like your printed sheets.

For example, the holes in the solids that you see in your screened file will not be there on your print, and tone readings in LEN or LENX files will not match printed tones.

This makes it difficult to perform quality control on such screens.

Imaging Engine offers a solution for this problem: when you are making your screened files for production, you can create **print simulation** files at the same time.

These print simulation files look like your production files, but with the advanced screening effects removed, so you can open them in the Bitmap Viewer and check exactly how your output will look like.

For example (you can see the screens with advanced effects on the left, and the print simulations on the right):



*PerfectHighlights screen at 2.5% (with support dots), and print simulation (with support dots removed)*

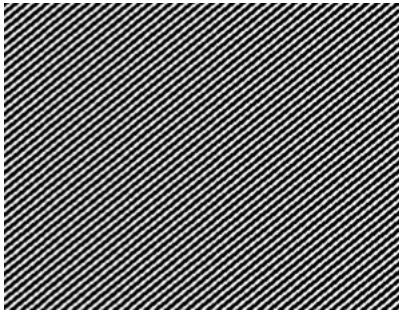

Groovy screen at 100% (with grooves), and print simulation (with grooves removed)



**Note:** This also applies to [predefined groovy screens](#) (GVY1 to GVV5).

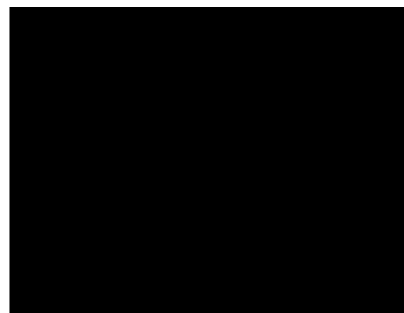
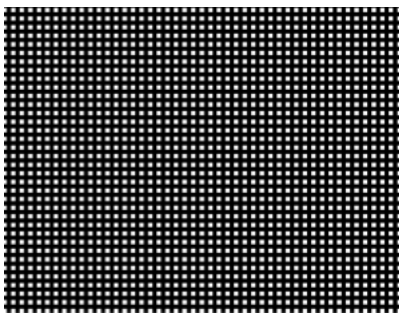

Platcell screen at 100% (with platcell pattern), and print simulation (with pattern removed)

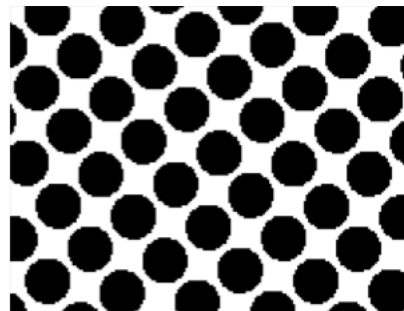

Microcell screen at 57% (with microcell holes), and print simulation (with microcell holes removed)

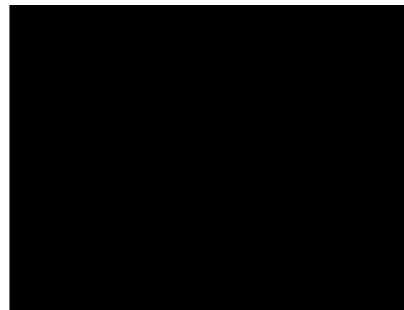
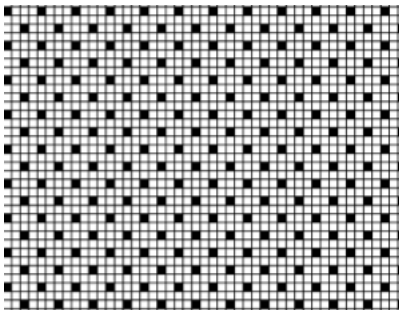

P+ Microcell screen at 100% (with pixel pattern), and print simulation (with pattern removed)



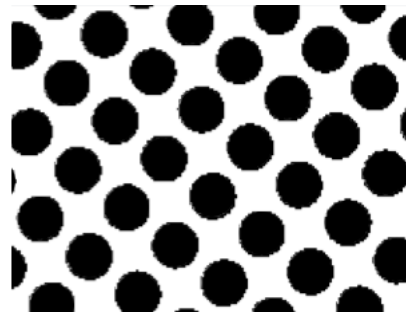

Concentric screen at 27% (with ring-shaped holes), and print simulation (with rings removed)



**Attention:**

Measuring the print simulation version of a concentric screen in the Bitmap Viewer will give slightly higher percentages than on the final print.

This is because unlike surface screening effects (groovy, platecell, microcell...), the main effect of concentric screening is not to improve ink lay-down but to print with a thinner ink layer.

### 16.3.4. Dot Gain Compensation

#### What is Dot Gain?

When printing a job, the dots tend to print larger on the press than on the plate, which makes the output darker than the original file.





Original job	
Plate	
Print	

This is due to different factors:

- the type of ink: the more fluid the ink is, the more it will spread under pressure of the press.
- the type of substrate: paper with a rougher and more porous surface (like uncoated paper) reflects less light, making the printed area look darker.
- the type of press:
  - offset presses typically print at a 67% density for a 50% dot,
  - flexo presses have an even higher dot gain as they put more pressure on the substrate,
  - gravure presses have a dot gain similar to offset presses for small dot sizes (up to about 30%) and a sharply increasing dot gain for higher percentages (70% prints as solid).

### What is Dot Gain Compensation?

To compensate for dot gain and have the printed output look like the original file, you use **dot gain compensation (DGC)**. This consists in making the dots on the plate smaller, so that with dot gain they print to the correct density.

	Dot on plate	Dot on press
Without DGC		
With DGC		

### Dot Gain Compensation Curves

You apply dot gain compensation by using a dot gain compensation curve, which defines which percentage to use on plate for each desired percentage on press.

In the example below, you see how a press prints without any dot gain compensation in the **dot gain curve** at left: a 20% on the plate prints to 57% on press. 57% on the plate would print to almost 90% on press.

At right, you see the **dot gain compensation curve** used to make the press print to the expected value in the job: to print a 57% on press, a 20% will be used on the plate. To print a 20% on press, you would need about 5% on the plate.

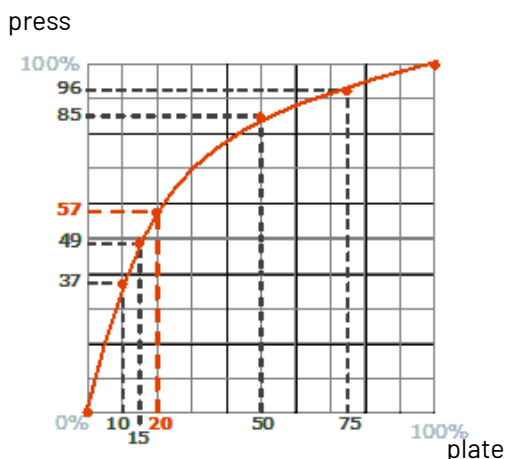

Dot gain curve

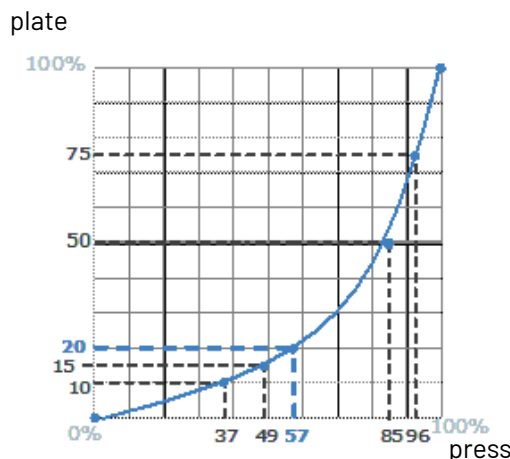

Dot gain compensation curve

### Creating a Dot Gain Compensation Curve

You can create dot gain compensation curves in Curve Pilot (for more information, see the Curve Pilot User Guide: <https://www.esko.com/en/support/product?id=Curve%20Pilot>).

Dot gain compensation curve files have the .dgc extension.

### Using a Dot Gain Compensation Curve

You can apply a dot gain compensation curve on all or some separations of your job in the [Image to Screened Separations](#) and [Image to Unscreened Separations](#) tasks in Imaging Engine.

## DGC Curve Strategies

### Different Dot Gains within a Job

When using a [single dot gain compensation curve](#), the same dot gain compensation is applied to the complete job, without making any compensation difference in the screening parameters, the inks or the type of content (continuous tone images or line work).

However, dot gain is influenced by those factors.

#### Screening parameters

The following parameters influence dot gain:

- The **dot shape**: for example square, round and elliptic dots have slightly different dot gain characteristics.  
Stochastic screens produce more dot gain in the mid-tones than conventional screens.  
See [Types of Screens Supported](#) on page 1197 for more information about dot shapes and screens.
- The **screen ruling**: dot gain only happens on the perimeter of the printing dots, which means that higher rulings always result in higher dot gain.  
For example, a double ruling means double dot gain.

#### Inks

Dot gain compensation on a Yellow separation is often less important and less needed than dot gain compensation on a Cyan separation.

The viscosity of the ink also has a big influence.

### Continuous tone images or line work

Sometimes, images have been pre-compensated for dot gain in an image editing program, so they need less dot gain compensation than linework.

### Dot Gain Compensation Curve Strategies

A **dot gain compensation curve strategy** contains several dot gain compensation curves, and defines when to apply which curve (it can have different curves per separation, dot shape, ruling, for continuous tone images or line work...).

### Creating a Dot Gain Compensation Curve Strategy

You can create dot gain compensation curve strategies in Curve Pilot (see the [Curve Pilot documentation](#) for more information).

Dot gain compensation curve files have the `.icpro` extension.

### Using a Dot Gain Compensation Curve Strategy

You can apply a dot gain compensation curve strategy in the [Image to Screened Separations](#) and [Image to Unscreened Separations](#) tasks in Imaging Engine.

Each job separation or object is automatically compensated with the appropriate dot gain compensation curve.



**Note:** You can also use legacy screen-based DGC files (`.scrdgc`) as dot gain compensation curve strategies in Imaging Engine.

### PressSync Curves

PressSync curves are predefined compensation curves that can cover the dot gain compensation needs of most presses, while significantly reducing the complexity of dot gain compensation in workflows.

### Slope and Mid-tone Compensation

Curves are defined by a letter and a number.

- The letter (A to H) describes how the press behaves in the highlights and shadows (the slope): an A curve makes the press print darker in the highlights and lighter in the shadows (for presses who have the opposite problem), while an H curve, on the contrary, makes the press print lighter in the highlights and darker in the shadows.

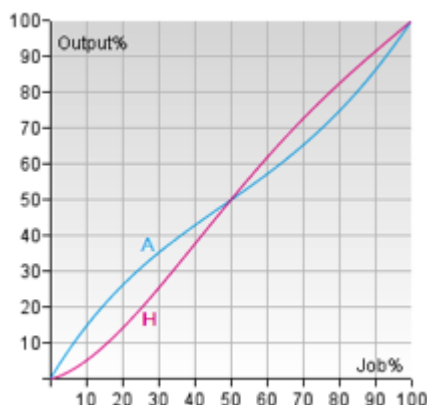

An E curve is halfway in between and has a straight slope: it corrects the output the same way throughout the range. Use it for presses whose output is consistent in the highlights, mid-tones and shadows.

- The number indicates how much the 50% dot (mid-tone) prints to: an E20 curve compensates the 50% dot to 20%, while an E70 curve compensates 50% to 70%.

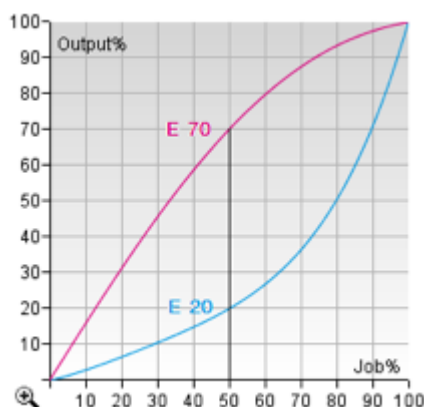

### Creating a PressSync Curve

You cannot create PressSync curves, they are predefined. There are 400 different PressSync curves, to match most dot gain compensation needs.

If you wish, you can see each PressSync curve on a graph in PressSync Pilot (for more information, see the Curve Pilot User Guide: <https://www.esko.com/en/support/product?id=Curve%20Pilot>).

### Using a PressSync Curve

You can apply a PressSync curve as press curve on all or some separations of your job in the [Image to Screened Separations](#) and [Image to Unscreened Separations](#) tasks in Imaging Engine (you just need to enter the letter and number of the PressSync curve).

### PressSync Curve Sets

A PressSync curve set contains several PressSync curves, each assigned to an ink (a process ink or any spot color defined in Esko's CMS database).

### Creating a PressSync Curve Set

You can create PressSync curve sets in PressSync Pilot (see the PressSync Pilot documentation for more information).

PressSync curve sets files have the `.prsync` extension.

### Using a PressSync Curve Set

You can apply a PressSync curve set as press curve in the [Image to Screened Separations](#) and [Image to Unscreened Separations](#) tasks in Imaging Engine.

Each job separation is automatically compensated with the appropriate PressSync curve.

### The Curves Database

All your [dot gain curves](#), [dgc curve strategies](#), [PressSync curves](#) and [PressSync curve sets](#) are stored in a curves database (also called "DGC database").

You install this curves database when installing Automation Engine. You can install it on your Automation Engine server or on another server (the server you install your curves, [screens](#) and [color management](#) databases on is called the "resources server").

After this, the dot gain curves, curve strategies, PressSync curves and curve sets in your curves database are automatically available in the [Imaging Engine tasks](#).

## 16.3.5. File Formats

Imaging Engine can output to the following formats:

#### For Proofing

- **TIFF**, a bitmap file format widely supported by image-processing, publishing, DTP and other applications.

Imaging Engine can generate [composite](#) TIFF proofs (with the [Image to Unscreened Proof](#) task).

- **PDF**, a multifunctional file format, supported by most graphics-related applications.

Imaging Engine can generate composite PDF proofs (with the [Image to Unscreened Proof](#) task).

- **JPEG**, an image file format widely used for photographs and preview images (with the [Image to Content Proof \(RGB\)](#) or [Image to Unscreened Proof](#) task).
- Imaging Engine can also generate proofs directly into your proofer's format for immediate proofing (with the [Proof for Content Approval](#) task).

#### For RIP'ing

- **TIFF**, a bitmap file format widely supported by image-processing, publishing, DTP and other applications.

You can output to [screened](#) or [unscreened](#) TIFF (with the [Image to Screened Separations](#) or [Image to Unscreened Separations](#) tasks).

- **PDF**, a multifunctional file format, supported by most graphics-related applications.

You can output to screened or unscreened PDF (with the [Image to Screened Separations](#) or [Image to Unscreened Separations](#) tasks).

- **LEN**, a bitmap file format developed for Esko's [Cyrel Digital Imager](#), or "CDI".

LEN files have high resolutions of 2100 ppi or more. They are always screened. You can output to LEN files with the [Image to Screened Separations](#) task.

You can then send your LEN files to your flexo plate making software (Automation Engine's Automated Flexo Plate Making module, the Digital Flexo Suite, or Grapholas), which will use them to expose flexo plates on the CDI drum.

- **LENX**, an encrypted version of the LEN file format developed exclusively for Esko's [CDI Crystal imager series](#) and [Crystal screens](#).

You can use the [Image to Screened Separations](#) task to generate them (they are always generated when you use [Crystal screens](#)).



**Note:** The file formats you can generate with your Imaging Engine software depend on your license. Please contact your Esko sales representative for more information.

## Composite and Separated Files

With Imagine Engine, you can generate either **composite** or **separated** files.

### Composite Files

Composite files are files that contain several separations.

Imaging Engine can generate composite **PDF** and composite **TIFF** files (from the [Image to Unscreened Separations](#) and [Image to Unscreened Proof](#) tasks).

**JPEG** output (from the [Image to Content Proof \(RGB\)](#) and [Image to Unscreened Proof](#) tasks) is always composite.

When generating composite output from:

- a single page input file, you get a single page output file containing all of the separations you choose to output (after excluding technical inks for example).

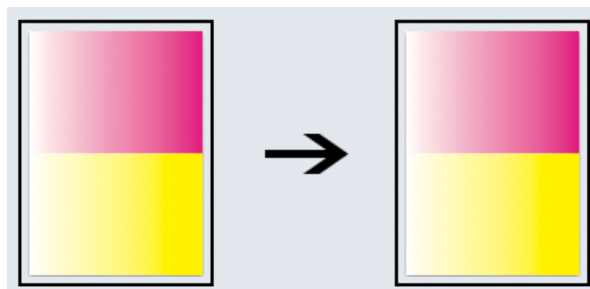

- a multi-page input file, you get one output file per page of the input file, containing all of the separations you choose to output from that input file page.

In the example below, the input file has 2 pages, containing respectively Magenta and Yellow, and Yellow and Cyan. When outputting to composite files, you get 2 one-page files, each containing the separations of the corresponding page in the input file.

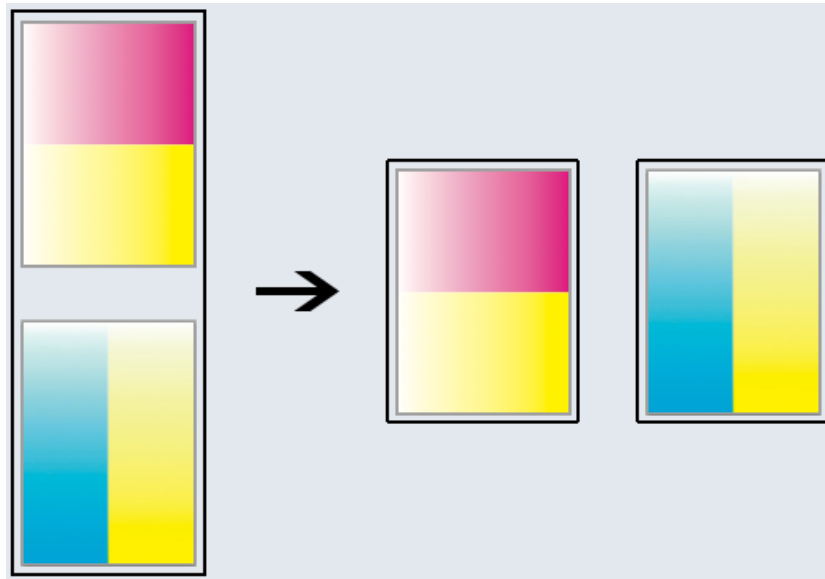

**Separated Files**

Separated files are files that only contain one separation each. Imaging Engine can generate separated **PDF, TIFF, LEN** and **LENX** files.

You can generate separated output using the *Image to Unscreened Separations* and the *Image to Screened Separations* tasks.

When generating separated output from:

- a single page input file, you get one output file per separation of the input file that you choose to output (after excluding technical inks for example).

In the example below, the input file has one page with a Magenta and a Yellow vignette. After RIP'ing, you get 2 files (one for each separation), each containing a single channel bitmap.

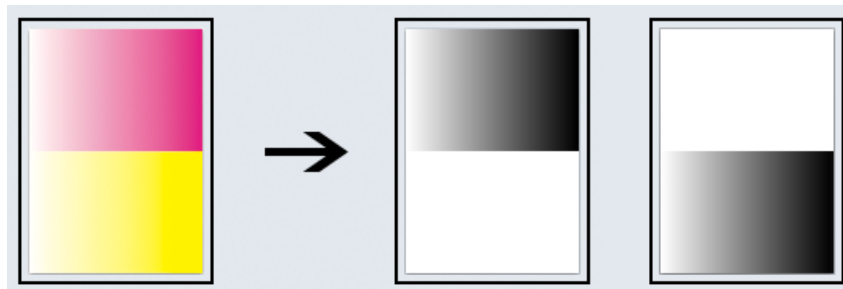

*Unscreened separated output*

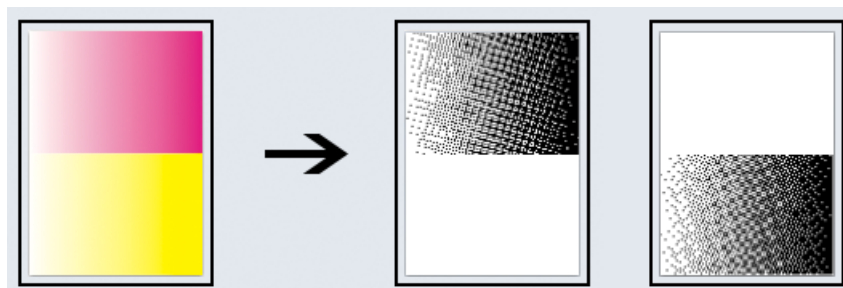



**Screened separated output**

- a multi-page input file, you get one output file per page of the input file and per separation that you choose to output.

In the example below, the input file has 2 pages, each containing a Magenta and a Yellow vignette. After RIP'ing, you get 4 files (one for the 1st separation of the 1st page, one for the 2nd separation of the 1st page, etc.), each containing a single channel bitmap.

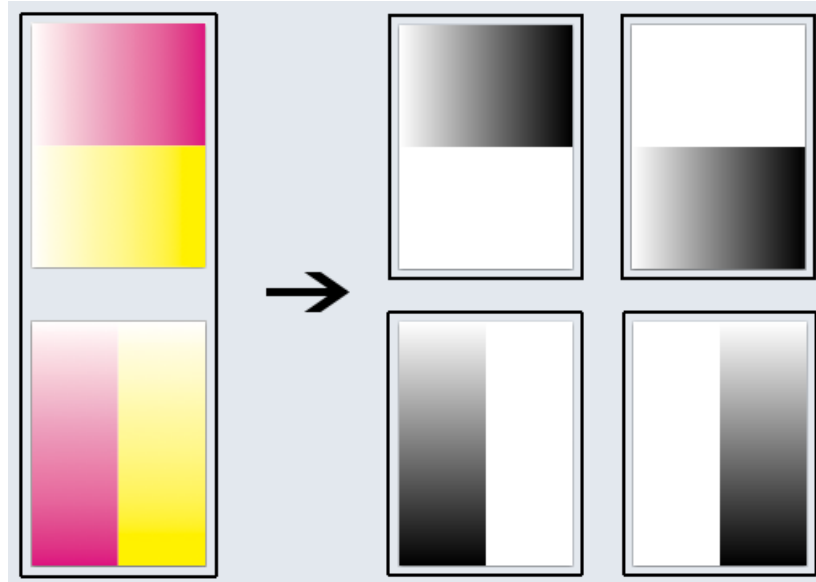

*Unscreened separated output*

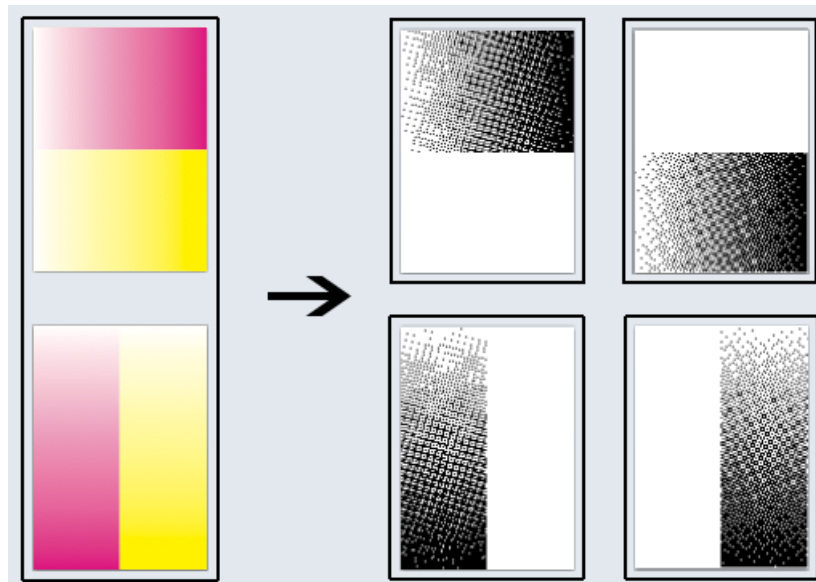

*Screened separated output*

### 16.3.6. Calculating Ink Distribution

If you print with an offset press, there is an extra quality step you can perform once your files have been proofed and RIP'ed and are production ready.

With Imaging Engine, you can generate CIP3 files, which are technical files containing information about the ink distribution in your production ready files.

When you send those CIP3 files to the press, the press software knows the amount of ink needed for each separation of your RIP'ed files, and where in the file it is needed.

It can then automatically calculate how to distribute the ink among the different print heads, without needing manual adjustments from the press operator.

This is faster and more accurate, and helps keep your prints "clean".

You can create CIP3 files using the [Calculate Ink Key Settings \(CIP3\)](#) task.

## 16.4. Imaging Engine Installation and Configuration

---

### 16.4.1. Licensing

To use the Imaging Engine functionality in Automation Engine, you need an Imaging Engine license (in the form of a product key file).

If you don't have this license, you will not be able to [configure Imaging Engine in the Automation Engine Pilot](#), or see [the Imaging Engine tasks](#).

Depending on the license you have, you will be able to output to some or all of the supported [output formats](#) (TIFF, PDF, LEN and LENX), and you may be limited to a certain output file size or not (for LEN files).

For more information about the available licenses and which would fit your production best, please talk to your Esko sales representative.

### 16.4.2. Installation

#### Installation or Upgrade?

##### Software Version

This document covers the installation of / upgrade to the latest version of **Imaging Engine** (and related applications):

Product version	<b>Imaging Engine 23</b>
Current release	<b>Imaging Engine July 2023 Release</b> also called <b>Imaging Engine 23.07</b>

For more information about the released version and build number of each of the applications, please see the **Released versions** page on the installation DVD.

### Installation or Upgrade?

If...

- no Esko software has been installed on your computer yet, you need to perform a new installation of Imaging Engine 23.07.

See [Installation Overview](#) on page 1229.

- Esko RIP or proofing software is installed on your computer, you need to upgrade to Imaging Engine 23.07 instead.

See [Upgrade Overview](#) on page 1239.

### Installation Overview

To use Imaging Engine, you will need to first license then install the following applications:

application:	before installing, please check:
<p><b>Automation Engine</b></p> <div style="border: 1px solid black; padding: 5px; margin-top: 10px;">  <p><b>Note:</b> You should have already installed Automation Engine before starting to install Imaging Engine and the Esko Proof Server.  See the Automation Engine installation documentation for details if needed.</p> </div>	<p>the <a href="#">Automation Engine system requirements</a></p>
<p><b>Imaging Engine</b></p>	<p>the <a href="#">Imaging Engine system requirements</a></p>
<p>the <b>Esko Proof Server</b> (if you are planning to proof using Imaging Engine and the Esko Proof Server)</p>	<p>the <a href="#">Esko Proof Server system requirements</a></p>

You can either install these applications on the same server, or on two or three different servers. If you install them on different servers, these servers need to be in the same Local Area Network.

#### General installation procedure:

1. Make sure you have the relevant DVDs.
  - To install Imaging Engine, you need the **Esko Software - Imaging Engine 23 Installation** DVD.
  - To install the Esko Proof Server, you need the **Esko Software - Pack Proof 23.07 Installation** DVD.



**Note:** If you downloaded the software from [MySoftware.esko.com](http://MySoftware.esko.com), you will need to mount the corresponding .iso files as virtual DVDs, or unpack the .iso files first.

2. Make sure you have the relevant **licenses**.  
You need a product key file for Imaging Engine 23 (which includes all necessary licenses). If you do not have a product key file yet, contact [Esko Customer Support](#).
3. On all servers on which you want to install Esko software, [prepare for the installation](#).

4. On your license server (which can be either your Automation Engine server or a central license server), [activate your licenses](#).
5. On the server on which you want to install Imaging Engine, perform the steps listed in [Installing Imaging Engine](#).
6. If you want to install the Esko Proof Server, perform the steps listed in [Installing the Esko Proof Server](#) on the server on which you want to install it.

### Preparing for the Installation

Before you install Imaging Engine 23.07 on your system, check the following:

- You need to have Administrator privileges.
- You need Internet access.
- Your computer must meet the minimum requirements for the installation, as described in the [System Requirements](#).
- You must make sure your anti-virus software is not blocking the installation or configuration.

### Activating the Licenses

Imaging Engine 23 is protected with licenses. These licenses are distributed as a product key file (in .html).

You need to activate the product keys in the product key file using the **Network License Manager** application, on the server that you are using as a **license server** (this can be either your Automation Engine server or a central license server).

You should have installed the Network License Manager as part of your Automation Engine installation. See the Automation Engine installation guide if needed.

You need:

- A product key file for Imaging Engine 23 (which includes all necessary licenses). If you do not have a product key file yet, contact [Esko Customer Support](#).
- Internet access on the server that you are using as a license server.
- An **Esko ID** in order to activate the licenses. You can get one at <http://www.esko.com/licensing/CreateAccount>.

On the server that you are using as a license server:

1. Open the **Network License Manager**.

Depending on your operating system, you can do this by:

- going to **Start > All Programs > Esko > Network License Manager > Network License Manager**,
  - clicking **Network License Manager** on your **Apps** screen.
2. In the **Esko Network License Manager**, do one of the following:
    - drag your product key file in the area marked **Drag your Product Key File or your Response file here**,
    - click the **Activate** button.
  3. Follow the instructions of the **Activate License Wizard**.
  4. When asked about the product keys, choose **I have received an HTML file containing my Product Keys**.
  5. Click **Browse** to select the product key file.
  6. When asked, fill in your **Esko ID** and **Password**.

**7. Click **Finish**.**

The licensed products you can use are now visible in the Network License Manager.

### Installing Imaging Engine

You need the **Esko Software - Imaging Engine 23 Installation** DVD for the installation. Use the following procedure to install Imaging Engine 23.07:

1. Open the **Esko Software - Imaging Engine 23 Installation** window:
  - If you insert the **Esko Software - Imaging Engine 23 Installation** DVD into the DVD drive, or mount the corresponding .iso file, the window appears automatically.
  - If you unpacked a downloaded .iso file, or if the window doesn't open automatically, double-click `setup.exe` in the root folder.
2. Select the installation language.
3. Click **Proceed to the installation**.
4. Under **Imaging Engine/Pack Proof 23 installation, including related tools (Color Pilot, Curve Pilot, HD Flexo Screens and ScreenManager)**, click **Install**.
5. On the page that opens:
  - a) If you [activated your licences](#) on a central license server (not the server on which you are installing Imaging Engine), connect your Imaging Engine server to this license server.  
See [How to Connect to the License Server](#) on page 1231 for details.
  - b) Check and install the prerequisites.  
See [How to Install the Imaging Engine Prerequisites](#) on page 1232.
  - c) Proceed with the software installation.  
See [How to Install Imaging Engine](#) on page 1233.
  - d) Install the Bitmap Viewer.  
See [How to Install the Bitmap Viewer](#) on page 1234.

#### How to Connect to the License Server

If you [activated your licences](#) on a central license server, you need to connect to this license server from your Imaging Engine server.

1. On the **Imaging Engine 23 Installer** page, click on **Install the Network License Manager**.
2. Follow the instructions of the installation wizard.
3. Back on the **Imaging Engine 23 Installer** page, click **Activate the licenses** to open the **Network License Manager**.
4. In the **Esko Network License Manager**, go to **Tools > License Client Configuration**.
5. In the **License Client Configuration** dialog:
  - a) Enter the name of the server that you are using as a [license server](#).  
If your license server is also the server you are installing Imaging Engine on, you can enter `localhost` here.
  - b) Click **Apply**.
  - c) Click **Exit**.
6. Close the **Network License Manager** and go back to the **Imaging Engine 23 Installer** page.

**How to Install the Imaging Engine Prerequisites**

Before you install Imaging Engine, you need to install the Imaging Engine prerequisites.

1. On the **Imaging Engine 23 Installer** page, click on **Check and install the Imaging Engine/Pack Proof System prerequisites**.

This checks whether the operating system is suited for installing and running Imaging Engine 23.07, and starts the Imaging Engine 23.07 prerequisites installation.

2. If:

- you see an error message about the Windows version, your operating system is not suited for running Imaging Engine 23.07.

Check the [System Requirements](#) again and install Imaging Engine 23.07 on a suitable operating system.

- you see the message `Ready to install the prerequisite components for the Imaging Engine software. Do you want to start the installation?, click Yes.`

3. The installation wizard for the prerequisite components will check the licenses, list the prerequisite components to install on the system, request confirmation for the installation and then install the required components.

Follow the instructions of the installation wizard.

The installation wizard will install the following components:

- Microsoft Visual Studio Redistributables
- Message Passing Interface service

If you are prompted to reboot your computer, do so and restart this installation procedure.

4. If the installer cannot find a running Automation Engine 23.07 server on the local machine, you will see the **Enter Server name** window, prompting you to enter the name of the server running your Automation Engine.



**Note:**

- You should be able to access this server from your Imaging Engine machine.
- You can still use the local machine as Automation Engine server (if Automation Engine 23.07 is installed on it): start up Automation Engine, and leave the field in the **Enter Server name** window blank.

The installer then checks if the server you entered has a running Automation Engine 23.07 server.

If you get the following error:	then:
<pre>ERROR - Imaging Engine requires Automation Engine 23.07 The provided master server does not have Automation Engine 23.07 running Checked server: [yourservername]</pre>	<p>Automation Engine 23.07 is not running on the server you entered.</p> <ol style="list-style-type: none"> <li>1. Check that you entered the server name correctly.</li> <li>2. Make sure Automation Engine 23.07 is running on it.</li> </ol>

If you get the following error:	then:
	<ol style="list-style-type: none"> <li>Restart the Imaging Engine prerequisites installation.</li> </ol>
<pre>ERROR - Imaging Engine requires Automation Engine 23.07 The provided master server does not have Automation Engine 23.07 installed Checked server: [yourservername] (version [yourserverversion])</pre>	<p>Automation Engine 23.07 is not installed on the server you entered.</p> <ol style="list-style-type: none"> <li>Check that you entered the server name correctly.</li> <li>Install Automation Engine 23.07 on it.</li> <li>Restart the Imaging Engine prerequisites installation.</li> </ol>

- Click **Exit** when the installation wizard is finished.

### How to Install Imaging Engine

- On the **Imaging Engine 23 Installer** page, click **Install the Imaging Engine/Pack Proof 23 products**.
- Follow the instructions of the installation wizard.
- Read the **End user license agreement** carefully and select **Yes, I accept the license agreement**.
- When asked to select the products to install on this system, select **Imaging Engine** and the desired related products (for example **ScreenManager, Curve Pilot, Color Pilot...**).
  - The products available depend on your license.
  - The **System Components** group cannot be deselected and will be installed on all systems.
  - The products' **Common Components** that are used by several products (for example **DGC Data** and **Color Management System**) will only be installed once (each product's installer will check if the necessary components are present, and update them if necessary).
  - You should already have installed the **screens** and the **printing conditions database** during your Automation Engine installation (as part of the Automation Engine **Common Components**), either on your Automation Engine server or on a central resources server.

The printing conditions database is where the [Print Control Wizard](#) tool saves any printing condition that you make.

See the Automation Engine installation guide if needed.

- Select a **Destination Folder** for the chosen products or use the default folder.
- In the **Set Automation Engine System Account** pop-up, enter the credentials (user name and password) of the system account you want to use for Automation Engine.



**Note:** The user name of the default Automation Engine system user is pre-filled in. You can either choose a password for this system user, or use different credentials.

These credentials will be stored and remembered during subsequent updates / upgrades of the software.

- At the end of the installation, click **Finish**.

**How to Install the Bitmap Viewer**

You can install the Bitmap Viewer either on the server hosting Imaging Engine, or on a separate computer. If you are installing it on a separate computer, please consult the [Bitmap Viewer system requirements](#) for that computer.



**Note:** If you want to install it on a Mac, please see [How to Install the Bitmap Viewer on Mac](#) on page 1234 instead.

1. On the installation page, click **Install the Bitmap Viewer 21 (64-bit) software**.
2. Follow the instructions of the installation wizard.
3. Select the **Destination Directory** or use the default folder.
4. Select the file types you want to associate with the **Bitmap Viewer** or keep the defaults.
5. Select the language to use or leave **Automatic** selected to use the computer's language.
6. Click **Install**.
7. When all components have been installed, close the installation window and eject the DVD.

**How to Install the Bitmap Viewer on Mac**

You can also install the Bitmap Viewer on its own on a Mac. Please consult the [Bitmap Viewer system requirements](#) to make sure your Mac is suitable for installing the Bitmap Viewer.

You can either:

- Install it from the **Esko Software - Imaging Engine 23 Installation** DVD you have on hand:
  - a) Go to the `BitmapViewer_XX_Installer` folder under the DVD root folder (where `XX` is the major version number, for example 21).
  - b) Install the **License Manager** (Esko Network License Manager `XX.XX.dmg` - where `XX.XX` is the full version number, for example 21.11).
  - c) Go to your `Applications` folder and open `Esko Network License Manager/ReadMe.rtf`.
  - d) Follow the instructions in the `ReadMe` file to start the **Esko License Server** and activate the **Bitmap Viewer license**.



**Note:** If you have a **DotSpy** license, you can also run the Bitmap Viewer on Mac using this license.

- e) Install the **Bitmap Viewer** (`Esko Bitmap Viewer.dmg`).
- Install it from [MySoftware.esko.com](http://MySoftware.esko.com):
  - a) Download and install the **Network License Manager** (of the same version as the Bitmap Viewer you want to install).
  - b) Go to your `Applications` folder and open `Esko Network License Manager/ReadMe.rtf`.
  - c) Follow the instructions in the `ReadMe` file to start the **Esko License Server** and activate the **Bitmap Viewer license**.



**Note:** If you have a **DotSpy** license, you can also run the Bitmap Viewer on Mac using this license.

- d) Download and install the **Bitmap Viewer**.





**Note:** Every time you reboot your Mac, make sure you restart the Esko License Server before launching the Bitmap Viewer.

### Repairing Your Installed Software

In case something goes wrong during the installation (for example, the Automation Engine server [you are connected to](#) goes offline while you are [installing your products](#)), you can repair your installation.

You can also repair/reinstall your software later, for example if:

- a component stops working because its program tree has become corrupt on the system,
- you loaded licenses for new functionality after your initial installation.



**Note:**

- You can only repair installed software that has the same version as the software in your installation DVD.

If you have a different version installed, either use/request an installation DVD of that version to repair it, or uninstall your software and [perform a new installation](#) using the installation DVD you have.

- If you have installed hotfixes, you will need to install them again after the repair/reinstallation.

1. From the DVD's home page, select the installation language then click **Proceed to the installation**.
2. Under **Imaging Engine/Pack Proof 23 installation, including related tools (Color Pilot, Curve Pilot, HD Flexo Screens and ScreenManager)**, click **Repair/re-install**.
3. On the next page, click on the software component that you want to repair:
  - **Repair the Network License Manager (including the License Server)**
  - **Repair/re-install installed Imaging Engine/Pack Proof 23 components**
4. If you are repairing the Network License Manager, follow the instructions of the installation wizard and click **Finish** when it is done.
5. If you are repairing one or more of the products:
  - a) Click **Next** on the first screen of the installation wizard.
  - b) Select the component(s) that need repair.



**Tip:**

After selecting a component, you can click the **Version Info** button to see more details about that component (the creation date, build number, installed date...).

You can also **Select All** or **Deselect All** components.

- c) Follow the instructions of the installation wizard.
- d) Click **Finish** when it is done.

### Installing the Esko Proof Server

If you are planning to proof using Imaging Engine and the Esko Proof Server, you now need to install the Esko Proof Server.

You need the **Esko Software - Pack Proof 23.07 Installation** DVD for the installation. Use the following procedure to install the Esko Proof Server:

1. Open the **Esko Software - Pack Proof 23.07 Installation** window:
  - If you insert the **Esko Software - Pack Proof 23.07 Installation** DVD into the DVD drive, or mount the corresponding .iso file, the window appears automatically.
  - If you unpacked a downloaded .iso file, or if the window doesn't open automatically, double-click `setup.exe` in the root folder.
2. Select the installation language.
3. Click **Proceed to the installation**.
4. On the **Esko Pack Proof 23 Installer** page:
  - a) If you [activated your licences](#) on a central license server (not the server on which you are installing the Esko Proof Server), connect your Esko Proof Server server to this license server. See [How to Connect to the License Server](#) on page 1236 for details.
  - b) Check and install the prerequisites. See [How to Install the Pack Proof Prerequisites](#) on page 1236.
  - c) Proceed with the software installation. See [How to Install the Esko Proof Server](#) on page 1237.
  - d) If you are installing the Esko Proof Server on a separate server (not your Automation Engine server), make sure that Automation Engine can send files to the Esko Proof Server share. See [Giving Automation Engine Access to the Esko Proof Server Share](#) on page 1239 for details.

#### **How to Connect to the License Server**

If you [activated your licences](#) on a central license server, you need to connect to this license server from your Esko Proof Server.

1. On the **Esko Pack Proof 23 Installer** page, click on **Install, update or repair the License Server (Network License Manager component)**.
2. Follow the instructions of the installation wizard. If the wizard asks you to restart the computer, do so, then relaunch the installation.
3. Back on the **Esko Pack Proof 23 Installer** page, click **Activate the licenses** to open the **Network License Manager**.
4. In the **Esko Network License Manager**, go to **Tools > License Client Configuration**.
5. In the **License Client Configuration** dialog:
  - a) Enter the name of the server that you are using as a [license server](#).
  - b) Click **Apply**.
  - c) Click **Exit**.
6. Close the **Network License Manager** and go back to the **Esko Pack Proof 23 Installer** page.

#### **How to Install the Pack Proof Prerequisites**

Before you install the Esko Proof Server, you need to install the Pack Proof prerequisites.

1. On the **Esko Pack Proof 23 Installer** page, click on **Check and install the Esko Pack Proof 23 Prerequisites**.

This checks whether the operating system is suited for installing and running your software, and starts the Pack Proof 23.07 prerequisites installation.

**2.** If:

- you see an error message about the Windows version, your operating system is not suited for running your software.

Check the [System Requirements](#) again and install your software on a suitable operating system.

- you see the message Ready to install the prerequisite components for the Imaging Engine software. Do you want to start the installation?, click **Yes**.

**3.** The installation wizard for the prerequisite components will check the licenses, list the prerequisite components to install on the system, request confirmation for the installation and then install the required components.

Follow the instructions of the installation wizard.

The installation wizard will install the following components:

- Microsoft Visual Studio Redistributables
- Message Passing Interface service

If you are prompted to reboot your computer, do so and restart this installation procedure.

**4.** Click **Exit** when the installation wizard is finished.

#### ***How to Install the Esko Proof Server***

**1.** On the **Esko Pack Proof 23 Installer** page, under **Install or upgrade the Esko Proof Server component**, click the **Install or upgrade the Esko Proof Server component** link.

This first checks if the prerequisite components are installed, and if you have the correct licenses.

Click **Yes** in the pop-up asking whether you want to install the Esko Proof Server component.

**2.** Follow the instructions of the installation wizard.

- If the wizard needs to install any redistributables, click **Yes** to install them.
- Select the **Destination Folder** to use for the installation, or use the default folder.
- At the end of the wizard, we recommend you select **Yes, I want to restart my computer now** before clicking **Finish**.

You can choose to restart your computer later, but you need to do so before using the application.



**Note:**

This also installs the Esko EPL linearization files for the proofing devices tested and supported by Esko.

An EPL linearization file adjusts how your proofer prints to get best results on a certain substrate (it adapts the quantities of inks used so that your proofer can achieve maximum color density without hue shifts).

Esko provides you with a number of EPL files made in controlled conditions for different proofer models and substrate types. We strongly recommend you use the one made for your proofer and substrate combination (before profiling your proofer). This will improve the color accuracy of your proofs. Please see [this knowledge base article](#) to know how to use and evaluate the EPL file(s) made for your proofer series.

3. After restarting your computer, the **Esko Server Control** application pops up.

Esko Server Control starts the Esko Proof Server automatically.

4. If you want to install **Fiery Command WorkStation** (the Client application of the Esko Proof Server) on the same server:

- a) If your computer has the Network License Manager installed, stop the Esko Network License Services before installing **Fiery Command WorkStation**.

If needed, contact Esko AfterCare for assistance.

- b) Relaunch the installation.
- c) Select your language and click **Proceed to the installation** to go back to the **Esko Pack Proof 23 Installer** page.
- d) Under **Install or upgrade the Esko Proof Server component**, click the **Install or upgrade the Fiery Command WorkStation component** link.
- e) Click **Yes** in the pop-up asking whether you want to install the Fiery Command WorkStation component.
- f) The **Fiery Command WorkStation Package** wizard installs Fiery Command WorkStation.  
The installation wizard may take a long time (up to one hour on some systems).
- g) At the end of the wizard, select **Yes, I want to restart my computer now** before clicking **Finish**.

Alternatively, you can install **Fiery Command WorkStation** on another machine using this same DVD.

5. If you want to install the **Fiery Verify** tool (the proof verification application of the Esko Proof Server) on the same server:

- a) Relaunch the installation.
- b) Select your language and click **Proceed to the installation** to go back to the **Esko Pack Proof 23 Installer** page.
- c) Under **Install or upgrade the Esko Proof Server component**, click the **Install or upgrade the Fiery Verify component** link.
- d) Click **Yes** in the pop-up asking whether you want to install the Fiery Verify component.
- e) The **Fiery Verify** wizard installs Fiery Verify.
- f) Click **Exit** at the end of the installation.

Alternatively, you can install **Fiery Verify** on another machine using this same DVD.

### Giving Automation Engine Access to the Esko Proof Server Share

If you installed the Esko Proof Server on a separate server (that has no other Esko software), you need to make sure that Automation Engine can send files to the Esko Proof Server share.



**Note:** If you installed the Esko Proof Server on the server where Automation Engine is installed, this is done automatically.

Do the following:

1. On the Automation Engine server, check under which user Automation Engine is running.

Automation Engine runs as a service under either a **local user** or a **Windows domain user**. You can see which user that is:

- in Automation Engine's **Server Admin**, under **System Account** (see the Automation Engine documentation for more details).
- in your Automation Engine server's **Task Manager** (in **Processes**, select **Show processes for all users**, and check which user the **bgmd.exe** process runs under).

2. On the server where you installed the Esko Proof Server, locate the `ProofFolder` share in which Automation Engine will send files to be printed by the Esko Proof Server.

If you used the default installation location (`C:\Esko`), this is `C:\Esko\ProofFolder`.

3. Give the Automation Engine user **Full Control** on this share.

- If the Automation Engine user is a **local user**:
  1. Make sure the same user exists on the Esko Proof Server computer (with the same password).
  2. Open the `ProofFolder`'s sharing properties (right-click it, select **Properties** and go to the **Sharing** tab).
  3. Add the user to the share with full rights (click **Share...**, type the user name and click **Add**, select **Read/Write** as **Permission Level** and click **Share** to confirm).
- If the Automation Engine user is a **Windows domain user**:
  1. Open the `ProofFolder`'s sharing properties (right-click it, select **Properties** and go to the **Sharing** tab).
  2. Add the user to the share with full rights (click **Share...**, type the user name and click **Add**, select **Read/Write** as **Permission Level** and click **Share** to confirm).

## Upgrade Overview

You can upgrade from any working previous version of Imaging Engine or FlexRip.

In case you need help with the upgrade (especially from older FlexRip versions), contact [Esko Customer Support](#).

If you have an Esko Proof Server:

- If you have a previous Esko Proof Server 20 installation (that came with a previous version of Imaging Engine/Pack Proof), you only need to update it to the latest build of Esko Proof Server 20, that comes with Imaging Engine/Pack Proof 23.07. See [How to Update the Esko Proof Server](#) on page 1247.

- If you have an Esko Proof Server 18.0 or older, you need to upgrade it instead. See [How to Upgrade the Esko Proof Server](#) on page 1246.



**Note:**

Make sure no users are using the system or are connected to the server.  
When upgrading, it is advised that all users save their work and create a backup.

**License and System Requirements:**

To upgrade Imaging Engine, you will need to first license then install the latest version of the following applications:

application:	before upgrading, please check:
<p><b>Automation Engine</b></p> <div data-bbox="261 768 327 833" data-label="Image"> </div> <p><b>Note:</b> You should have already upgraded Automation Engine before starting to upgrade Imaging Engine and the Esko Proof Server.  See the Automation Engine installation documentation for details if needed.</p>	<p>the <a href="#">Automation Engine system requirements</a></p>
<p><b>Imaging Engine</b></p>	<p>the <a href="#">Imaging Engine system requirements</a></p>
<p>the <b>Esko Proof Server</b> (if you are planning to proof using Imaging Engine and the Esko Proof Server)</p>	<p>the <a href="#">Esko Proof Server system requirements</a></p>



**Note:**

If you have a distributed setup (these applications are installed on two or three different servers), you should keep the same setup for the upgrade.  
  
However, please make sure that the server hosting Automation Engine, the one hosting the Esko Proof Server, and your proofing device(s) are in the same Local Area Network.

**General upgrade procedure:**

1. Make sure you have the relevant DVDs.
  - To upgrade Imaging Engine, you need the **Esko Software - Imaging Engine 23 Installation** DVD.
  - To upgrade the Esko Proof Server, you need the **Esko Software - Pack Proof 23.07 Installation** DVD.



**Note:** If you downloaded the software from [MySoftware.esko.com](http://MySoftware.esko.com), you will need to mount the corresponding .iso files as virtual DVDs, or unpack the .iso files first.

2. Make sure you have the relevant **licenses**.

You need a product key file for Imaging Engine 23 (which includes all necessary licenses). If you do not have a product key file yet, contact [Esko Customer Support](#).

3. On your license server (which can be either your Automation Engine server or a central license server), [activate your licenses](#).
4. On the server on which you want to upgrade Imaging Engine, perform the steps listed in [Upgrading Imaging Engine](#).
5. If you want to upgrade the Esko Proof Server, perform the steps listed in [Upgrading the Esko Proof Server](#) on the server on which you want to upgrade it.

### Activating the Licenses

Imaging Engine 23 is protected with licenses. These licenses are distributed as a product key file (in .html).

You need to activate the product keys in the product key file using the **Network License Manager** application, on the server that you are using as a **license server** (this can be either your Automation Engine server or a central license server).

You should have installed the Network License Manager as part of your Automation Engine installation. See the Automation Engine installation guide if needed.

You need:

- A product key file for Imaging Engine 23 (which includes all necessary licenses). If you do not have a product key file yet, contact [Esko Customer Support](#).
- Internet access on the server that you are using as a license server.
- An **Esko ID** in order to activate the licenses. You can get one at <http://www.esko.com/licensing/CreateAccount>.

On the server that you are using as a license server:

1. Open the **Network License Manager**.

Depending on your operating system, you can do this by:

- going to **Start > All Programs > Esko > Network License Manager > Network License Manager**,
- clicking **Network License Manager** on your **Apps** screen.

2. In the **Esko Network License Manager**, do one of the following:

- drag your product key file in the area marked **Drag your Product Key File or your Response file here**,
- click the **Activate** button.

3. Follow the instructions of the **Activate License Wizard**.

4. When asked about the product keys, choose **I have received an HTML file containing my Product Keys**.

5. Click **Browse** to select the product key file.

6. When asked, fill in your **Esko ID** and **Password**.

7. Click **Finish**.

The licensed products you can use are now visible in the Network License Manager.

### Upgrading Imaging Engine

You need the **Esko Software - Imaging Engine 23 Installation** DVD for the upgrade. Use the following procedure to upgrade to Imaging Engine 23.07:

1. Open the **Esko Software - Imaging Engine 23 Installation** window:
  - If you insert the **Esko Software - Imaging Engine 23 Installation** DVD into the DVD drive, or mount the corresponding .iso file, the window appears automatically.
  - If you unpacked a downloaded .iso file, or if the window doesn't open automatically, double-click `setup.exe` in the root folder.
2. Select the installation language.
3. Click **Proceed to the installation**.
4. Under **Imaging Engine/Pack Proof 23 installation, including related tools (Color Pilot, Curve Pilot, HD Flexo Screens and ScreenManager)**, click **Install**.
5. On the page that opens:
  - a) If you are using a central license server, connect to it.  
See [How to Connect to the License Server](#) on page 1231 for details.
  - b) Check and install the prerequisites.  
See [How to Upgrade the Imaging Engine Prerequisites](#) on page 1242.
  - c) Proceed with the software upgrade.  
See [How to Upgrade Imaging Engine](#) on page 1243.
  - d) Update/upgrade the Bitmap Viewer.  
See [How to Upgrade the Bitmap Viewer](#) on page 1244.

#### **How to Connect to the License Server**

If you [activated your licences](#) on a central license server, you need to connect to this license server from your Imaging Engine server.

1. On the **Imaging Engine 23 Installer** page, click on **Install the Network License Manager**.
2. Follow the instructions of the installation wizard.
3. Back on the **Imaging Engine 23 Installer** page, click **Activate the licenses** to open the **Network License Manager**.
4. In the **Esko Network License Manager**, go to **Tools > License Client Configuration**.
5. In the **License Client Configuration** dialog:
  - a) Enter the name of the server that you are using as a [license server](#).  
If your license server is also the server you are installing Imaging Engine on, you can enter `localhost` here.
  - b) Click **Apply**.
  - c) Click **Exit**.
6. Close the **Network License Manager** and go back to the **Imaging Engine 23 Installer** page.

#### **How to Upgrade the Imaging Engine Prerequisites**

Before you upgrade Imaging Engine, you need to upgrade the Imaging Engine prerequisites.

1. On the **Imaging Engine 23 Installer** page, click on **Check and install the Imaging Engine/Pack Proof System prerequisites**.  
This checks whether the operating system is suited for installing and running Imaging Engine 23.07, and starts the Imaging Engine 23.07 prerequisites installation.
2. If:



- you see an error message about the Windows version, your operating system is not suited for running Imaging Engine 23.07.

In this case you need to perform a *fresh installation* on a suitable operating system instead. Check the *System Requirements*.

- you see a message saying that the prerequisite components will be upgraded, click **OK**.
3. The installation wizard for the prerequisite components will check the licenses, list the prerequisite components to upgrade on the system, request confirmation for the upgrade and then upgrade the required components.

Follow the instructions of the installation wizard.

The installation wizard will upgrade the following components:

- Microsoft Visual Studio Redistributables
- Message Passing Interface service

If you are prompted to reboot your computer, do so and restart this installation procedure.

4. The installer then checks if Automation Engine 23.07 is running on your Automation Engine server.

If you get the following error:	then:
<pre>ERROR - Imaging Engine requires Automation Engine 23.07 The provided master server does not have Automation Engine 23.07 running Checked server: [yourservername]</pre>	<p>Automation Engine 23.07 is not running on the server you entered.</p> <ol style="list-style-type: none"> <li>1. Check that you entered the server name correctly.</li> <li>2. Make sure Automation Engine 23.07 is running on it.</li> <li>3. Restart the Imaging Engine prerequisites installation.</li> </ol>
<pre>ERROR - Imaging Engine requires Automation Engine 23.07 The provided master server does not have Automation Engine 23.07 installed Checked server: [yourservername] (version [yourserverversion])</pre>	<p>Automation Engine 23.07 is not installed on the server you entered.</p> <ol style="list-style-type: none"> <li>1. Check that you entered the server name correctly.</li> <li>2. Install Automation Engine 23.07 on it.</li> <li>3. Restart the Imaging Engine prerequisites installation.</li> </ol>

5. Click **Exit** when the installation wizard is finished.

### How to Upgrade Imaging Engine

1. On the **Imaging Engine 23 Installer** page, click **Install the Imaging Engine/Pack Proof 23 products**.
2. Follow the instructions of the installation wizard.
3. Read the **End user license agreement** carefully and select **Yes, I accept the license agreement**.
4. When asked to select the products to install on this system, select **Imaging Engine** and the desired related products (for example **ScreenManager, Curve Pilot, Color Pilot...**).
  - The products available depend on your license.

- The **System Components** group cannot be deselected and will be installed on all systems.
- The products' **Common Components** that are used by several products (for example **DGC Data** and **Color Management System**) will only be installed once (each product's installer will check if the necessary components are present, and update them if necessary).
- You should already have installed the **screens** and the **printing conditions database** during your Automation Engine installation (as part of the Automation Engine **Common Components**), either on your Automation Engine server or on a central resources server.

The printing conditions database is where the [Print Control Wizard](#) tool saves any printing condition that you make.

See the Automation Engine installation guide if needed.

5. At the end of the installation, click **Finish**.

#### *How to Upgrade the Bitmap Viewer*

1. On the installation page, click **Install the Bitmap Viewer 21 (64-bit) software**.
2. Follow the instructions of the installation wizard.
3. Select the **Destination Directory** or use the default folder.
4. Select the file types you want to associate with the **Bitmap Viewer** or keep the defaults.
5. Select the language to use or leave **Automatic** selected to use the computer's language.
6. Click **Install**.
7. When all components have been installed, close the installation window and eject the DVD.

#### **Upgrading the Esko Proof Server**

If you are planning to proof using Imaging Engine and the Esko Proof Server, you now need to upgrade the Esko Proof Server.

You need the **Esko Software - Pack Proof 23.07 Installation** DVD for the upgrade. Use the following procedure to upgrade the Esko Proof Server:

1. Back up the data from your existing Esko Proof Server.
 

Please see the documentation of your existing Esko Proof Server version on the [Pack Proof documentation page](#) for details.
2. Open the **Esko Software - Pack Proof 23.07 Installation** window:
  - If you insert the **Esko Software - Pack Proof 23.07 Installation** DVD into the DVD drive, or mount the corresponding .iso file, the window appears automatically.
  - If you unpacked a downloaded .iso file, or if the window doesn't open automatically, double-click `setup.exe` in the root folder.
3. Select the installation language.
4. Click **Proceed to the installation**.
5. On the **Esko Pack Proof 23 Installer** page:
  - a) If you are using a central license server, connect to it.
 

See [How to Connect to the License Server](#) on page 1236 for details.
  - b) Check and install the prerequisites.

See [How to Install the Pack Proof Prerequisites](#) on page 1236.

c) Proceed with the software upgrade.

See [How to Upgrade the Esko Proof Server](#) on page 1246.

6. Restore the Esko Proof Server data you backed up.

Please see the Esko Proof Server documentation on the [Pack Proof documentation page](#) for details.

#### **How to Connect to the License Server**

If you [activated your licences](#) on a central license server, you need to connect to this license server from your Esko Proof Server.

1. On the **Esko Pack Proof 23 Installer** page, click on **Install, update or repair the License Server (Network License Manager component)**.
2. Follow the instructions of the installation wizard.  
If the wizard asks you to restart the computer, do so, then relaunch the installation.
3. Back on the **Esko Pack Proof 23 Installer** page, click **Activate the licenses** to open the **Network License Manager**.
4. In the **Esko Network License Manager**, go to **Tools > License Client Configuration**.
5. In the **License Client Configuration** dialog:
  - a) Enter the name of the server that you are using as a [license server](#).
  - b) Click **Apply**.
  - c) Click **Exit**.
6. Close the **Network License Manager** and go back to the **Esko Pack Proof 23 Installer** page.

#### **How to Install the Pack Proof Prerequisites**

Before you install the Esko Proof Server, you need to install the Pack Proof prerequisites.

1. On the **Esko Pack Proof 23 Installer** page, click on **Check and install the Esko Pack Proof 23 Prerequisites**.

This checks whether the operating system is suited for installing and running your software, and starts the Pack Proof 23.07 prerequisites installation.

2. If:
  - you see an error message about the Windows version, your operating system is not suited for running your software.  
Check the [System Requirements](#) again and install your software on a suitable operating system.
  - you see the message `Ready to install the prerequisite components for the Imaging Engine software. Do you want to start the installation?, click Yes.`
3. The installation wizard for the prerequisite components will check the licenses, list the prerequisite components to install on the system, request confirmation for the installation and then install the required components.

Follow the instructions of the installation wizard.

The installation wizard will install the following components:

- Microsoft Visual Studio Redistributables

- Message Passing Interface service

If you are prompted to reboot your computer, do so and restart this installation procedure.

4. Click **Exit** when the installation wizard is finished.

#### How to Upgrade the Esko Proof Server

1. On the **Esko Pack Proof 23 Installer** page, under **Install or upgrade the Esko Proof Server component**, click the **Install or upgrade the Esko Proof Server component** link.

2. Follow the instructions of the installation wizard.

- a) If the wizard needs to install any redistributables, click **Yes** to install them.
- b) Click **Yes** in the pop-up asking to remove your previous Esko Profiles.

If you are instructed to restart your computer, do so and then relaunch the installation.

- c) Click **Yes** in the pop-up asking to remove your previous Esko Proof Server version.

If you are instructed to restart your computer, do so and then relaunch the installation.

- d) At the end of the wizard, we recommend you select **Yes, I want to restart my computer now** before clicking **Finish**.

You can choose to restart your computer later, but you need to do so before using the application.



#### Note:

This also installs/updates the Esko EPL linearization files for the proofing devices tested and supported by Esko.

An EPL linearization file adjusts how your proofer prints to get best results on a certain substrate (it adapts the quantities of inks used so that your proofer can achieve maximum color density without hue shifts).

Esko provides you with a number of EPL files made in controlled conditions for different proofer models and substrate types. We strongly recommend you use the one made for your proofer and substrate combination (before profiling your proofer). This will improve the color accuracy of your proofs. Please see [this knowledge base article](#) to know how to use and evaluate the EPL file(s) made for your proofer series.

3. After restarting your computer, the **Esko Server Control** application pops up.

Esko Server Control starts the Esko Proof Server automatically.

4. If you want to upgrade the Esko Proof Client to **Fiery Command WorkStation** (the new name of the Esko Proof Server's client application) on this same server:

- a) If your computer has the Network License Manager installed, stop the Esko Network License Services before installing **Fiery Command WorkStation**.

If needed, contact Esko AfterCare for assistance.

- b) Relaunch the installation.
- c) Select your language and click **Proceed to the installation** to go back to the **Esko Pack Proof 23 Installer** page.
- d) Under **Install or upgrade the Esko Proof Server component**, click the **Install or upgrade the Fiery Command WorkStation component** link.

- e) Click **Yes** in the pop-up asking whether you want to install the Fiery Command WorkStation component.
  - f) The **Fiery Command WorkStation Package** wizard installs Fiery Command WorkStation.  
The installation wizard may take a long time (up to one hour on some systems).
  - g) At the end of the wizard, select **Yes, I want to restart my computer now** before clicking **Finish**.  
Alternatively, you can upgrade it on another machine using this same DVD.
- 5.** If you want to upgrade the Verification tool to **Fiery Verify** (the new name of the Esko Proof Server's proof verification application) on this same server:
- a) Relaunch the installation.
  - b) Select your language and click **Proceed to the installation** to go back to the **Esko Pack Proof 23 Installer** page.
  - c) Under **Install or upgrade the Esko Proof Server component**, click the **Install or upgrade the Fiery Verify component** link.
  - d) Click **Yes** in the pop-up asking whether you want to install the Fiery Verify component.
  - e) The **Fiery Verify** wizard installs Fiery Verify.
  - f) Click **Exit** at the end of the installation.  
Alternatively, you can upgrade it on another machine using this same DVD.
- 6.** Restore the Esko Proof Server data you backed up.  
Please see the Esko Proof Server documentation on the [Pack Proof documentation page](#) for details.

#### **How to Update the Esko Proof Server**

If you have a previous Esko Proof Server 20 installation (that you used with a previous version of Imaging Engine), you only need to update it to the latest build of Esko Proof Server 20, released with Imaging Engine 23.07 and Pack Proof 23.07.

(If you have an Esko Proof Server 18.0 or older, you need to [upgrade it](#) instead.)

- 1.** On the **Esko Pack Proof 23 Installer** page, under **Install or upgrade the Esko Proof Server component**, click the **Install or upgrade the Esko Proof Server component** link.
- 2.** Follow the instructions of the installation wizard.
  - a) If the wizard needs to install any redistributables, click **Yes** to install them.
  - b) Click **Yes** in the pop-up asking to update the Esko Proof Server component.
  - c) In the **Esko Proof - InstallShield Wizard**, select **Repair** and click **Next**.

The wizard updates your Esko Proof Server version. Click **Finish** when the update is done, then **Exit** when the post-installation step is done in the **Esko Proof Server Installation** window.



**Note:**

This also installs/updates the Esko EPL linearization files for the proofing devices tested and supported by Esko.

An EPL linearization file adjusts how your proofer prints to get best results on a certain substrate (it adapts the quantities of inks used so that your proofer can achieve maximum color density without hue shifts).

Esko provides you with a number of EPL files made in controlled conditions for different proofer models and substrate types. We strongly recommend you use the one made for your proofer and substrate combination (before profiling your proofer). This will improve the color accuracy of your proofs. Please see [this knowledge base article](#) to know how to use and evaluate the EPL file(s) made for your proofer series.

3. To update your **Fiery Command WorkStation** application (the Esko Proof Server's client application) on this same server:

a) If your computer has the Network License Manager installed, stop the Esko Network License Services before installing **Fiery Command WorkStation**.

If needed, contact Esko AfterCare for assistance.

b) Under **Install or upgrade the Esko Proof Server component**, click the **Install or upgrade the Fiery Command WorkStation component** link.

The installer checks whether your installed version of Fiery Command WorkStation requires an update.

- If it doesn't, click **Exit**.

Then restart your computer if it has the Network License Manager installed and you have stopped the Esko Network License Services.

- If it doesn't but a hotfix is available, follow the instructions on screen to install the hotfix.

Then restart your computer if it has the Network License Manager installed and you have stopped the Esko Network License Services.

- If it does, follow the rest of the steps below.

c) Click **Yes** in the pop-up asking whether you want to install the Fiery Command WorkStation component.

d) The **Fiery Command WorkStation Package** wizard installs Fiery Command WorkStation.

The installation wizard may take a long time (up to one hour on some systems).

e) At the end of the wizard, select **Yes, I want to restart my computer now** before clicking **Finish**.

Alternatively, you can install it on another machine using this same DVD.

4. To update your **Fiery Verify** tool (the Esko Proof Server's proof verification tool) on this same server:

a) Relaunch the installation.

Select your language and click **Proceed to the installation** to go back to the **Esko Pack Proof 23 Installer** page.

b) Under **Install or upgrade the Esko Proof Server component**, click the **Install or upgrade the Fiery Verify component** link.

The installer checks whether your installed version of Fiery Verify requires an update.

- If it doesn't, click **Exit**.
- If it does, follow the rest of the steps below.
- c) Click **Yes** in the pop-up asking whether you want to install the Fiery Verify component.
- d) The **Fiery Verify** wizard installs Fiery Verify.
- e) Click **Exit** at the end of the installation.

Alternatively, you can install it on another machine using this same DVD.

## Installing the Automation Engine SaaS Tools

If you are working in a **SaaS** (Software as a Service) environment, your Automation Engine and Imagine Engine software are hosted by Esko and not installed on your local servers.

However, you will probably need to install some software locally, for when you need to edit or manage your resources:

- Color Pilot, to manage your color resources,
- Curve Pilot, to manage your curves resources,
- HD Flexo Screens, to manage your HD Flexo screens,
- ScreenManager, to manage your custom screens.

You can install these "Automation Engine SaaS tools" (or "Calibration tools") using the **Esko Software - Imaging Engine 23 Installation** DVD.

1. On all servers on which you want to install Esko software, [prepare for the installation](#).
2. On the computer on which you want to install the Automation Engine SaaS tools, perform the steps listed in [Installing the Automation Engine SaaS tools](#).
3. Activate the licenses of the software you want to use:
  - a) Your **Color Pilot**, **Curve Pilot** and **ScreenManager** licenses have normally already been activated on your Automation Engine SaaS server by the Esko team.
  - b) Activate the **HDFlexo** license on the computer you are installing the Automation Engine SaaS tools on.

See [Activating the HDFlexo License](#) on page 1251.

If you don't you have the correct licenses yet, contact [Esko Customer Support](#).

## Preparing for the Installation

Before you install the [Automation Engine SaaS tools](#) on your system, check the following:

- You need to have Administrator privileges.
- You need Internet access.
- Your computer must meet the minimum requirements for the applications you want to install, please consult the [System Requirements](#).
- You must make sure your anti-virus software is not blocking the installation or configuration.

## Installing the Automation Engine SaaS Tools

On the computer on which you want to install the Automation Engine SaaS tools:

1. Open the DVD installer:

- If you insert the **Esko Software - Imaging Engine 23 Installation** DVD into the DVD drive, or mount the corresponding .iso file, the installation window appears automatically.
  - If you unpacked a downloaded .iso file, or if the installation window doesn't open automatically, double-click `setup.exe` in the root folder.
2. Select the installation language.
  3. Click **Proceed to the installation**.
  4. Under **Automation Engine SaaS Tools 23 installation (Automation Engine Editor Connection Tools, Color Pilot, Curve Pilot, HD Flexo Screens and ScreenManager)**, click **Install**.
  5. On the **Automation Engine SaaS Tools 23 Installer** page:
    - a) Check and install the prerequisites.  
See [How to Install the Automation Engine SaaS Tools Prerequisites](#) on page 1250.
    - b) Proceed with the software installation.  
See [How to Install the Automation Engine SaaS Tools](#) on page 1250.

#### **How to Install the Automation Engine SaaS Tools Prerequisites**

Before you install the Automation Engine SaaS tools, you need to install the Automation Engine SaaS tools prerequisites.

1. On the **Automation Engine SaaS Tools 23 Installer** page, click on **Check and install the Automation Engine SaaS Tools 23 System prerequisites**.

This checks whether the operating system is suited for installing and running the Automation Engine SaaS tools, and starts the prerequisites installation.

2. If:

- you see an error message about the Windows version, your operating system is not suited for running the Automation Engine SaaS tools.

Check the [System Requirements](#) again and install the Automation Engine SaaS tools on a suitable operating system.

- you see the message `Ready to install the prerequisite components for the Automation Engine SaaS Tools software. Do you want to start the installation?`, click **Yes**.

3. The installation wizard for the prerequisite components will check the licenses, list the prerequisite components to install on the system, request confirmation for the installation and then install the required components.

Follow the instructions of the installation wizard.

The installation wizard will install the following components:

- Microsoft Visual Studio Redistributables
- Message Passing Interface service

If you are prompted to reboot your computer, do so and restart this installation procedure.

4. Click **Exit** when the installation wizard is finished.

#### **How to Install the Automation Engine SaaS Tools**

1. On the **Automation Engine SaaS Tools 23 Installer** page, click **Install the Automation Engine SaaS Tools 23 products**.



2. Follow the instructions of the installation wizard.
3. Read the **End user license agreement** carefully and select **Yes, I accept the license agreement**.
4. When asked to select the products to install on this system, select the desired products (for example **ScreenManager, Curve Pilot, Color Pilot...**).

On Windows, make sure you select the **Automation Engine Editor Connection Tools** component (this installs the Automation Engine syncer tool, that connects the local applications you install to your SaaS databases).

5. Select a **Destination Folder** for the chosen products or use the default folder.
6. Next you will be prompted to enter the Automation Engine SaaS Server name and the login credentials to check the licenses for the applications.
  - a) First, the **Color Pilot** and **ScreenManager** licenses will be checked.
    1. You will be prompted to enter the **Automation Engine host name** where the required licenses are defined.
    2. You will then need to sign in to the Automation Engine SaaS Server.
  - b) You will be prompted in the same way again to check for **Curve Pilot** and **HDFlexo** licenses.



**Note:**

- If the Color Pilot or Curve Pilot licenses are not found, the installation will be stopped with an error.
- If ScreenManager or HDFlexo licenses are not found, you will receive a warning but will still be able to continue with the installation. The applications will be installed but you will not be able to use them without the license.

7. At the end of the installation, click **Finish**.

You now have a Color Pilot shortcut icon on your desktop. You can open the other resource editors (Curve Pilot, HD Flexo Screens and ScreenManager) from Color Pilot's **Curves** or **Screens** explorers as needed (please see the Color Pilot documentation for more details). This is because these editors use Color Pilot to connect to your SaaS screens and curves databases.



**Note:**

If you already had Color Pilot, Curve Pilot, HDFlexo Screens or ScreenManager shortcut icons on your desktop, these are local applications connecting to local databases (not SaaS). Make sure to not mix them up with the ones you just installed that connect to your SaaS databases!

When working with your SaaS data, always open Curve Pilot, HDFlexo Screens and ScreenManager from Color Pilot.

### Activating the HDFlexo License

To use the HDFlexo application and HDFlexo screens, you need to first activate your **HDFlexo Screens Generator(IE\_HDFLEXO\_230)** license and the **HDFlexo Screens(RSSCRC00HD)** license in the Network License Manager that is automatically installed.

These licenses are distributed as product key file(s)(in .html).

If you don't you have the product key files yet, contact [Esko Customer Support](#).

1. Open the **Network License Manager**.

Depending on your operating system, you can do this by:

- going to **Start > All Programs > Esko > Network License Manager > Network License Manager**,

- clicking **Network License Manager** on your **Apps** screen.
- 2. In the **Network License Manager**, do one of the following:
  - a) drag your product key file in the area marked **Drag your Product Key File or your Response file here**,
  - b) click the **Activate** button.
- 3. Follow the instructions of the **Activate License Wizard**.
- 4. When asked about the product keys, choose **I have received an HTML file containing my Product Keys**.
- 5. Click **Browse** to select the product key file.
- 6. When asked, fill in your **Esko ID** and **Password**.



**Note:** If you don't have your **Esko ID** yet, you can get one at <http://www.esko.com/licensing/CreateAccount>.

- 7. Click **Finish**.  
The licensed products you can use are now visible in the **Network License Manager**.

### Repairing the Automation Engine SaaS Tools

In case something goes wrong during the [Automation Engine SaaS Tools installation](#), you can repair it.

You can also repair/reinstall your software later, for example if:

- a component stops working because its program tree has become corrupt on the system,
- you loaded licenses for new functionality after your initial installation.



**Note:**

- You can only repair installed software that has the same version as the software in your installation DVD.  
  
If you have a different version installed, either use/request an installation DVD of that version to repair it, or uninstall your software and [perform a new installation](#) using the installation DVD you have.
- If you have installed hotfixes, you will need to install them again after the repair/reinstallation.

1. From the DVD's home page, select the installation language then click **Proceed to the installation**.
2. Under **Automation Engine SaaS Tools 23 installation (Automation Engine Editor Connection Tools, Color Pilot, Curve Pilot, HD Flexo Screens and ScreenManager)**, click **Repair/re-install**.
3. On the next page, click on the software component that you want to repair:
  - **Repair the Network License Manager (including the License Server)**
  - **Repair/re-install installed Automation Engine SaaS Tools 23 components**
4. If you are repairing the Network License Manager, follow the instructions of the installation wizard and click **Finish** when it is done.
5. If you are repairing one or more of the Automation Engine SaaS Tools:
  - a) Click **Next** on the first screen of the installation wizard.
  - b) Select the component(s) needing repair.



**Tip:**

After selecting a component, you can click the **Version Info** button to see more details about that component (the creation date, build number, installed date...).

You can also **Select All** or **Deselect All** components.

- c) Follow the instructions of the installation wizard.
- d) Click **Finish** when it is done.

### 16.4.3. Configuration in the Automation Engine Pilot

After installing all the software components required for Imaging Engine, you need to launch the Automation Engine Pilot and perform some configuration:

1. Connect your Automation Engine server to your Imaging Device and perform general Imaging Engine configuration.  
See [Imaging Engine Configuration](#) on page 1253.
2. If you are planning to proof using Imaging Engine and the Esko Proof Server, you also need to connect those two components.  
See [Connecting Imaging Engine to the Esko Proof Server](#) on page 1256.

#### Imaging Engine Configuration





**Note:**

- You need to perform this configuration before you can use Imaging Engine.
- If you have already configured Imaging Engine, you can only edit the configuration while it is not processing files (if it is processing files while you try to change the configuration, you will see a warning, and will have to wait until the processing is done).

To connect your Automation Engine server to your Imaging Device:

1. In the Automation Engine Pilot, go to **Tools > Configure**.
2. Select **Imaging Engines** in the left pane.
3. Go to **File > New** or press the **Insert** key (on PC).  
This creates an **Imaging1** entry under **Imaging Engines** and shows settings in the right pane.
4. In the right pane's **General** tab:
  - a) In **Host Name**, enter the name of the server running your Imaging Engine and press **Enter** or **Tab** (or click the **Connect** button next to **Imaging Engine**).
  - b) Check that you see a green dot with the message **Imaging Engine is up and running**.

If you see...	it means that...
a grey dot  with the message <b>Imaging Engine is starting up on host</b>	you need to wait a few minutes before you can use Imaging Engine.

If you see...	it means that...
a red dot  with the message <b>No license for Imaging Engine on host</b>	your Imaging Engine license is missing. Please check your licenses.
a red dot  with the message <b>No Imaging Engine available on host</b>	the server you have entered doesn't have Imaging Engine or even Automation Engine installed.  Please check if you have entered the server name wrong.

You may see other error messages in some cases, but you will always get some advice as to what you need to do (for example with the  **Missing resource for Imaging Engine on host** message, you will get advised to `Please reinstall the Imaging Engine`).



**Note:** You can **Stop** and **Start** Imaging Engine from here for troubleshooting purposes, but this is generally not necessary, as Imaging Engine starts automatically, and will restart automatically in case of a crash or after being force quitted.

- c) Set the **Number of Workers**. This is the number of parallel processes used to work on multiple pages of a file, or multiple files at the same time.



**Note:**

The maximum number of workers you can set depends on your license and on the number of cores on your server.

Please see the [system requirements page](#) for details.

- d) The **Maximum Memory Limit** is the maximum amount of memory a worker can use to process a file. In most cases, you should keep the default **Maximum Memory Limit** as it is. However:
  - If you need to process some really complex files and/or you had issues with Imaging Engine running out of memory when processing some of your files in the past, you can raise that limit.



**Attention:**

The **Maximum Memory Limit** cannot be larger than the **Available Physical Memory** (indicated above) divided by the **Number of Workers**.

If you enter a value that is too large, it will be automatically changed to the maximum value possible.

- If you are only processing simple files that don't require a lot of memory, you can lower that limit.



**Attention:**

If you try to process a file that needs more than the **Maximum Memory Limit** that you have allocated, the processing can fail.

You cannot lower the limit to less than 1 GB/1024 MB. If you enter a value that is too small, it will be automatically changed to the minimum value possible.

You can enter your desired value in gigabytes (GB) or megabytes (MB), or without a unit. When using GB, your value will be converted to MB, and when not using a unit, it will be taken as MB.

You will see a warning when trying to change the **Maximum Memory Limit**.

5. In the **Settings** tab:

- a) Select what kind of *Rosettes* you want to use in the *Image to Screened Separations task*:

- **Clear Centered** rosettes are generally considered to be more stable. This is the default.
- **Dot Centered** rosettes can give a more saturated result.

You can see which imaging device and which kind of rosettes have been used for each file in that file's log.

- b) Enable (check) **Minimum Ruling** if you want to enforce a minimum ruling, and optionally edit the minimum ruling value. The default value in an Imaging Engine device is 65 lpi. You can enter a minimum ruling as low as 1 lpi.



**Note:** The minimum ruling value has no effect unless **Minimum Ruling** is enabled (checked).

- c) Enable (check) **Maximum Ruling** if you want to enforce a maximum ruling, and optionally edit the maximum ruling value. The default value in an Imaging Engine device is 300 lpi.



**Note:** The maximum ruling value has no effect unless **Maximum Ruling** is enabled (checked).



**Note:** When both **Minimum Ruling** and **Maximum Ruling** are enabled (checked), the minimum ruling value cannot be higher than the current maximum ruling value. In case **Minimum Ruling** is enabled last, the minimum ruling value is decreased automatically to the current maximum ruling value; in case **Maximum Ruling** is enabled last, the maximum ruling value is increased automatically to the current minimum ruling value.

- d) Check that `Jump to nearest ruling` is selected under the **Exact Ruling not Available** list. This is the default setting, ensuring that the closest available ruling value will be used when the exact requested ruling value is not implemented. In case using the exact requested ruling value is a hard constraint, select `Task fails` under the **Exact Ruling not Available** list.
- e) If you use `Jump to nearest ruling`, you can additionally enable (check) **Maximum Ruling Difference** to edit the maximum ruling difference value that you can tolerate. The default maximum ruling difference in an Imaging Engine device is 10 lpi.

To clarify the usage of these parameters and their inter-workings, a few representative examples are shown below. In all the examples, available rulings are assumed to be 65, 70, 80, 90, 100, 110, 120, 130, 135, and 140 lpi.

**Example 1:** The requested ruling is 75 lpi. **Minimum Ruling** is disabled (unchecked); the actual minimum ruling value does not matter. `Jump to nearest ruling` is selected with a maximum

ruling difference of 10 lpi. The nearest available rulings to 75 lpi observing the maximum ruling difference of 10 lpi are 70 and 80 lpi. The lower value of 70 lpi will be used. The task will succeed.

**Example 2:** The requested ruling is 60 lpi. **Minimum Ruling** is enabled (checked); the actual minimum ruling value is 68 lpi. `Jump to nearest ruling` is selected with a maximum ruling difference of 5 lpi. The nearest available ruling to 60 lpi observing the maximum ruling difference of 5 lpi is 65 lpi. This value cannot be used because it is lower than the minimum ruling of 68 lpi. The task will fail.

**Example 3:** The requested ruling is 60 lpi. **Minimum Ruling** is enabled (checked); the actual minimum ruling value is 68 lpi. `Jump to nearest ruling` is selected with a maximum ruling difference of 10 lpi. The nearest available rulings to 60 lpi observing the maximum ruling difference of 10 lpi are 65 and 70 lpi. The value of 65 lpi cannot be used because it is lower than the minimum ruling of 68 lpi. The value of 70 lpi is higher than the minimum ruling and can be used. The task will succeed.

**Example 4:** The requested ruling is 145 lpi. **Maximum Ruling** is disabled (unchecked); the actual maximum ruling value does not matter. `Jump to nearest ruling` is selected with a maximum ruling difference of 10 lpi. The nearest available ruling to 145 lpi observing the maximum ruling difference of 10 lpi is 140 lpi. This value will be used. The task will succeed.

**Example 5:** The requested ruling is 145 lpi. **Maximum Ruling** is enabled (checked); the actual maximum ruling value is 138 lpi. `Jump to nearest ruling` is selected with a maximum ruling difference of 10 lpi. The nearest available rulings to 145 lpi observing the maximum ruling difference of 10 lpi are 140 and 135 lpi. The value of 140 lpi is higher than the maximum ruling and cannot be used. The value of 135 lpi is lower than the maximum ruling and can be used. The task will succeed.

6. In the **Queue** tab, enter a name for your Imaging Engine **Queue**.
7. In the left pane, select the **Imaging1** entry, go to **File > Rename** and give it a meaningful name.  
You can also select it and press **F2** (on PC).
8. Go to **File > Save** or use **Ctrl+S** (on PC) to save your configuration.

If you changed the configuration while Imaging Engine was running (but not processing files), it will restart with the updated configuration.

## Connecting Imaging Engine to the Esko Proof Server

This configuration will connect your **Automation Engine** server (and Imaging Engine) to your **Esko Proof Server**, so that Imaging Engine can send files to the Proof Server, for proofing on your device.

For more flexibility, you can connect to several Proof Servers, and have access to all the workflows configured on these Proof Servers. When sending files through Imaging Engine's **Proof for Content Approval** task, you can then select which workflow of which Proof Server you want to use.



**Important:** You need to perform this configuration before you can use the **Proof for Content Approval** task.

1. In the Automation Engine Pilot, go to **Tools > Configure**.
2. Select **Proof Servers** in the left pane.
3. For each Proof Server that you want to connect to:
  - a) Click **Add** at the bottom of the right pane.
  - b) In the **New Proof Server** pop-up, enter the name of the server on which your Proof Server is running, and click **Add**.



**Note:**

If you get an error message like The shared folder "ProofFolder" on the host is not writable for the user BGSYSTEM, it means that Automation Engine cannot access the Proof Server share (where it needs to send files to proof).

In this case, follow the steps in [Giving Automation Engine Access to the Esko Proof Server Share](#) on page 1239.

- c) In the **Status** column, check that your Proof Server is **Running**. You also can **Remove** the connection to a Proof Server if needed.
- 4. Go to **File > Save** or use **Ctrl+S** (on PC) to save your configuration.

## 16.5. The Imaging Engine Tasks

Imagine Engine consists of:

- three proofing tasks: [Proof for Content Approval](#), [Image to Content Proof \(RGB\)](#) and [Image to Unscreened Proof](#),
- two RIP'ing tasks: [Image to Screened Separations](#) and [Image to Unscreened Separations](#),
- a task to help the press calculate the ink needed to print the RIP'ed files: [Calculate Ink Key Settings \(CIP3\)](#).

For a general introduction to each task's purpose, see [Using Imaging Engine for Proofing and RIP'ing](#).

### Using SmartNames and Public Parameters in the Imaging Engine Tasks

Use the Imaging Engine tasks as you would use other Automation Engine tasks. For most of the settings, you can also use public parameters (so an operator can define them through Shuttle) and/or SmartNames.

You can use SmartNames everywhere you see the SmartName icon , and you can use SmartNames in public parameters even for settings without that icon (for example if the setting is a button).



**Important:** SmartNames values must resolve to a value that is valid for that setting at the moment the task runs. Any invalid SmartName value will make the task end in error.



**Tip:**

- SmartNames are case insensitive (for example it doesn't matter whether your SmartName resolves to `AngleAndRuling` or `angleandruling`).
- To know what value a SmartName must resolve to for a specific setting:
  1. select the setting value you want (for example **Scale : Fit to page size**),
  2. right-click that value (**Fit to page size**) and select **Copy Parameter Value**,
  3. paste the value in a text editor (in this example it is `FitSize`).

For more information about SmartNames and public parameters, see the **SmartNames** and **Using Public Parameters** sections of the Automation Engine manual.



### 16.5.1. Proof for Content Approval

You can use the **Proof for Content Approval** task for generating a **content proof** and sending it automatically to your proofer. You typically make a content proof to check whether the contents of your file (layout, text, barcodes...) are correct.

At that stage, you are typically not checking the color accuracy of your proof yet, so the **Proof for Content Approval** task only performs some default color management, based on the ISO standard, in the background (for example to convert RGB objects to CMYK so they are printable).

When you are satisfied with the content proof and want to make a contract proof with color management, you can use the *Image to Unscreened Proof* task.

#### Proofing with the Proof for Content Approval Task

The **Proof for Content Approval task**  sends the ready-to-proof files to the **workflow** of your choice on the **Esko Proof Server** , who then proofs it automatically on the proofer connected to that workflow. This proofer can be one of many types of *proofing devices supported* by the Esko Proof Server.

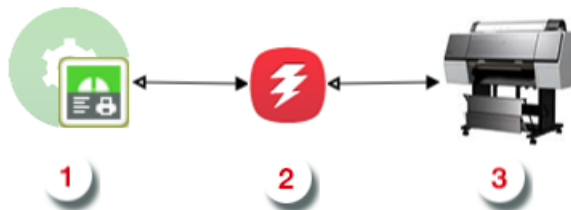

**Note:**

To use this task, you need to have created a printer, workflow and media in Fierey Command WorkStation (the client application of the Esko Proof Server). Make sure that the correct media is selected in the **Media Associated** option in the **Print Settings** tab of the workflow.

For information about creating a Proof Server workflow, please see the Esko Proof Server documentation, available from the *Pack Proof documentation page*.



**Attention:**

You can use several Proof Servers, but in this case, make sure that every workflow has a unique name, even across Proof Servers.

If there are workflows with the same name on several Proof Servers, you will not be able to send files to those workflows through the **Proof for Content Approval** task.

#### Task Parameters

In the **Device** field, select the imaging device *that you configured*.



Then use the tabs at left to show more settings to fill in. See:

- [General](#) on page 1259,
- [Proofer](#) on page 1260,
- [Transformations](#) on page 1262,
- [PDF Objects](#) on page 1264,
- [Processing Steps](#) on page 1265
- [Inks](#) on page 1269,
- [Output](#) on page 1276,
- [Summary](#) on page 1280.

### Using the Proof Server Workflow Parameters

If you are using a **Proof Server workflow** that already has proofing parameters defined (for example the number of copies to print, or the rotation or scaling to apply to your file), those parameters will be filled in by default in the **Proof for Content Approval** task, so that you don't have to go check them in the Proof Server workflow and copy them into the task.



**Note:** This is not the case if you are using a SmartName or a public parameter to select your Proof Server workflow.

You can of course change those parameters as desired in the **Proof for Content Approval** task.

### General

1. Define what **Page Box** of the input PDF you want to proof.

You can either select **Media Box**, **Trim Box**, or insert a SmartName  that must resolve to either `media` or `trim`.

After selecting your file's page box you will see its dimensions under the **Page Box** option.

2. If your input file is a multi-page PDF, select which **Pages** you want to proof:

- a) First select **All pages**, **Odd pages only** or **Even pages only** in the **Pages** option.

You can also insert a SmartName resolving to either `All`, `Even` or `Odd`.

- b) Then you can refine your selection by entering page numbers or a **Page Range**.

You can separate page numbers by a comma, or use a dash to indicate a page range (for example `3, 6-9`). You can also use a SmartName resolving to page numbers and/or page ranges using this same format.



**Note:**

- Page numbers are always physical pages. If your document starts with page 5, you should not use 5 but 1 to get the first page.
- If you enter page numbers that are not part of your document, they will be excluded from the output (all the other valid pages will be proofed).
- If you enter the same page(s) more than once (for example `1, 1-2`), it/they will only be output once.
- Pages are proofed in the order of the document (entering `5-1` will be automatically changed to `1-5`).

3. If you want to invert your output so it is compatible with the output device or software system that will process it, click .

You can also click  or **Edit...** to insert a SmartName that must resolve to `1` or `true` (to invert the output), or to `0` or `false` (to leave the output as it is).



**Tip:** If that setting is already defined in your *Proof Server workflow*, it will be filled in by default. You can of course change it as desired.

4. If you want to mirror your output so it is compatible with the output device or software system that will process it, click .

You can also click  or **Edit...** to insert a SmartName that must resolve to `1` or `true` (to mirror the output), or to `0` or `false` (to leave the output as it is).

If that setting is already defined in your Proof Server workflow, it will be filled in by default. You can of course change it as desired.

5. If you want to add **SmartMarks (Classic)** or **Dynamic Marks** in your output file(s), select the **Type of Marks** you want to add and then select the specific **Mark Set** you want to use.

**SmartMarks (Classic)** or **Dynamic Marks** are marks whose content is variable, so you can make them display information about that specific job and use them as a production control. For example, you can include some of the parameters used during RIP'ing in your output file(s) by using SmartMarks (Classic) or Dynamic Marks.

You need to:

- a) First create the SmartMarks (Classic) you want to use in **PackEdge** or **Plato** and the Dynamic Marks in **ArtPro+** (see the PackEdge, Plato and Arpro+ manuals for more details).

You can create either:

- a general SmartMark (Classic) or Dynamic Mark (for example a corner mark or split mark),
- a Text Mark with Smart Text, that will display the information included in your input file,
- an Imaging Engine-specific Text Mark with Smart Text, that will display the parameters that you set in the ticket.

To do this, select **Output Parameter** in the **Smart Text** pop-up in the PackEdge/ArtPro+ application. Make sure you use the RIP-related SmartMark attributes from the **Output Parameter** category, and not those from the **Ink/Color** category.

If your PackEdge, Plato or ArtPro+ application is linked to your Automation Engine server, your SmartMarks (Classic) or Dynamic Marks will automatically be saved in the correct location and will be available in Imaging Engine.

- b) Then select that SmartMark (Classic) or Dynamic Mark in your **Imaging Engine task** using the **Mark Set** option.

The SmartMarks (Classic) or Dynamic Marks will be added to each proof generated from your input file.

## Proofer

This is where you select the *Esko Proof Server workflow* to which the task sends your RIP'ed output.

1. In the **Proof Server Workflow** list, you can see all of the valid workflows found on the Proof Server(s) *you are connected to*.



**Note:**

To use this task, you need to have created a printer, workflow and media in Fiery Command WorkStation (the client application of the Esko Proof Server). Make sure that the correct media is selected in the **Media Associated** option in the **Print Settings** tab of the workflow.

For information about creating a Proof Server workflow, please see the Esko Proof Server documentation, available from the [Pack Proof documentation page](#).



**Attention:**

If you are connected to several Proof Servers, make sure that every workflow has a unique name, even across Proof Servers.

If there are workflows with the same name on several Proof Servers, you will not be able to select any of those workflows here (the name will be greyed out).

You can:

- select a workflow from the list,
- use SmartNames (that must resolve to the name of a valid Proof Server workflow),
- set the workflow using public parameters.



**Tip:**

When you select a workflow from the list, its proofing parameters (number of copies to print, rotation or scaling to apply to your file...), will be filled in by default in the **Proof for Content Approval** task, so that you don't have to go check them in the Proof Server workflow and copy them into the task.

You can of course change those parameters as desired in the **Proof for Content Approval** task.

2. In **Submit Method**, choose how you want to submit your print jobs to your Proof Server workflow.

You can either have the Esko Proof Server print them directly, or keep them in the "held" queue, so that you can make changes in Fiery Command WorkStation (for example, add them to a manual nesting).

- Choose **Default from Proof Workflow** to use the setting defined in the Proof Server workflow.



**Tip:**

You can find this setting in Fiery Command WorkStation's **Server Manager** view: select your proofer and workflow, then go to **File > Job Detection**.

If **Put all incoming jobs on hold** is selected, print jobs will stay in the "held" queue until you print them manually from Command WorkStation. They will be shown as **Spoiled** in Command WorkStation's **Job Center** list.

If **Put all incoming jobs on hold** is deselected, they will be printed automatically as they arrive.

For more information, see the Esko Proof Server documentation, available from the [Pack Proof documentation page](#).

- Choose **Hold in Proof queue** if you want to disregard the **Put all incoming jobs on hold** setting in Command WorkStation, and always keep jobs (launched with this ticket) on hold in Command WorkStation's **Job Center** list (shown as **Spoiled**).

In Automation Engine's **Tasks** view, the task is in the waiting state  until the job is printed in Command WorkStation.

- Choose **Print** if you want to disregard the **Put all incoming jobs on hold** setting in Command WorkStation, and have the Esko Proof Server always automatically print jobs (launched with this ticket).

## Transformations

Use the **Transformations** settings to scale or rotate your output relative to your input file.





**Tip:**

If you are using a [Proof Server workflow](#) that already has scaling and/or rotation parameters defined, those parameters will be filled in by default, so that you don't have to go check them in the Proof Server workflow and copy them into the task.

You can of course change those parameters as desired.

1. If you want to **Scale** your input file's contents, select either:

- **Scale by percent** and enter the vertical  and horizontal  scaling percentages to use (they must be between 10% and 1000%).



**Note:**

By default, you enter the vertical scaling percentage and the horizontal one is calculated automatically to keep the proportions.

If you want to enter the horizontal scaling percentage manually, click  to unlink it from the vertical one first.

However, if you do this then link the percentages again, the last percentage you entered will be kept, and the other one will be recalculated automatically to keep the proportions.

- **Fit to page size** to fit your output to the substrate defined in your [Proof Server workflow](#), while keeping the proportions (this will fit it to either the width or the height of the substrate, while making sure everything is on the substrate).
- **Fit to page width** to fit it to the width of the substrate defined in your Proof Server workflow, while keeping the proportions.

If you [added SmartMarks](#) to your output, they will be taken into account when fitting the proof to the substrate's width or size.



**Note:**

If you have chosen to print borderless in your Proof Server workflow, the task will take this into account when fitting your output to the substrate, and make your output slightly larger to cover the whole substrate width or height.

You can only print borderless if your proofing device supports it. Please check the Esko Proof Server documentation (available from the [Pack Proof documentation page](#)) and your proofing device documentation for more information about borderless printing.

If you don't want to scale your file's contents, leave **Do not scale** selected.

You can use SmartNames resolving to `not` (**Do not scale**), `ByPercent` (**Scale by percent**), `FitSize` (**Fit to page size**) or `FitWidth` (**Fit to page width**).

When entering SmartNames for vertical and horizontal scaling percentages, they must resolve to the numerical value (without the % sign).

2. If you want to rotate your file, select the **Rotation** you want to apply here.

You can choose to either:

- use a fixed rotation (this can be **0°**, **90° Counter Clockwise**, **90° Clockwise** or **180°**; any other value will give an error),
- rotate your file if necessary to fit, or fit better, on the substrate (select **Minimal Media Consumption**). This can be useful when using narrow rolls of substrate for example.

If it did fit on the substrate already, this option makes sure that the largest dimension of the file will be placed in the substrate width, to use less substrate material when cutting.

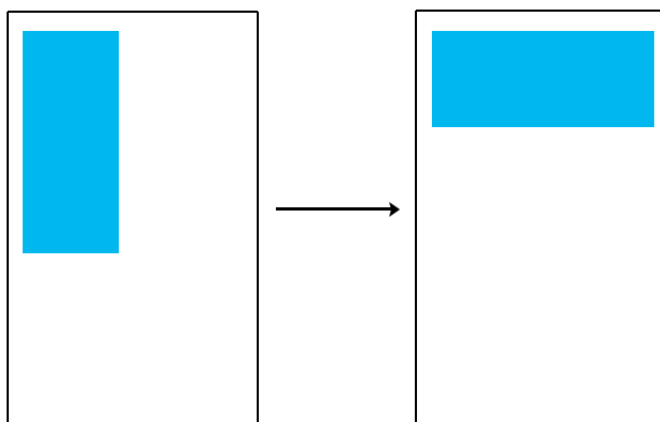

**Note:**

- If you have chosen to print borderless in your Proof Server workflow, the task will take the extra space into account when rotating your file to fit (or fit better) on the substrate.
- You can use a SmartName that resolves to 0, 90 (for **90° Counter Clockwise**), 180, 270 (for **90° Clockwise**), or `minimal`.
- When using a fixed rotation, you need to use a numerical value (`ninety` will not work).
- This is a public parameter, that you can fill in when submitting files through Shuttle.

## PDF Objects

1. If you experience issues with a font that doesn't look smooth enough at your selected resolution, your font may have **font hinting errors**.

Font hinting is the rendering of the outline (vectorized) font to pixels. For certain fonts, this rendering sometimes doesn't give a visually pleasing result, especially at low resolutions. In the image below, the top font has font hinting errors, the bottom font doesn't.

Label Pack  
Label Pack

Choose how to handle files containing font hinting errors:

- Leave **Task ends in error when the job contains font hinting errors** selected if you want the task to end in error when encountering font hinting errors. You can also use a SmartName resolving to `true`.
- Deselect **Task ends in error when the job contains font hinting errors** if you want to output your file anyway, whether it has font hinting errors or not (your task will end with a warning). You can also use a SmartName resolving to `false`.

This may lead to reduced quality rendering of the text, but it will not generate incorrect characters in your output file.

2. If your PDF+ input file has linked artwork and the external reference files have been modified, the changes do not get updated automatically in the PDF+ file. This will result in outdated data in the input as well as output files.

Choose how to handle files containing **outdated linked artwork**:

- Select **Task ends in error when linked artwork is not up to date** if you want the task to end in error if the input file contains outdated external references. You can also use a SmartName resolving to `true`.

- Deselect **Task ends in error when linked artwork is not up to date** if you want to output the file anyway, whether the references are outdated or not (your task will end with a warning). You can also use a SmartName resolving to `false`. This is the default option.

## Processing Steps

### What is a Processing Step?

PDF input files typically contain different types of objects, used at different stages of the production process: not only printable objects (that make up the design), but also other objects containing **post-processing data** (for example a cut path or crease lines).

Your production workflow needs to handle these object types accordingly.

If your customers, suppliers, etc. all define their post-processing data in their own way (for example a die cut path could be in a separation called "die" or "cut"), it can lead to:

- needing to make the production workflow more complex to catch all possibilities,
- loss of time,
- mistakes (possibly wasting plates or having a wrong print).

Imaging Engine and Pack Proof support the [ISO 19593 standard](#), that defines "**processing steps**" corresponding to different types of post-processing data. With input files that use these processing steps, you can work in a more uniform way, increasing efficiency and decreasing mistakes.

### Processing Step Groups

The **ISO 19593 standard** groups the different processing steps as follows:

#### Structural Data

Contours indicating how the printed product will be processed to make a 3D end product.

These include for example cutting, creasing and folding lines, and correspond to operations performed by finishing devices like die cutters, folder-glueers, etc.

#### Braille

Contours of objects representing braille content. The braille characters are made after printing, typically by a die cutter or inkjet device.

#### Legend

PDF objects outside the boundaries of the actual printed product (for example solid patches of the inks used in the design). They can contain job related data used in review, approval, and manual production steps.

#### Dimensions

These are also outside the printed area, and indicate the physical size of certain items in the design (using arrows, numbers and units).

#### Positions

Contours giving the position of certain graphic elements (for example where a barcode should be, or which area of a folding carton flap can be printed). They can also be used to indicate areas where graphic elements shouldn't be printed.

#### White

PDF objects indicating where the white backing ink (the opaque white ink used for white underprint on transparent or metallic substrates) will be on the design.

**Varnish**

PDF objects indicating where the varnish will go after printing.

Imaging Engine and Pack Proof also include the following custom processing steps groups by default:

**Esko\_PlateCutting**

Contours indicating how a flexo plate needs to be cut.

**Esko\_PlateID**

PDF objects containing information to identify the plate.



**Note:**

See [Structural Data Processing Steps](#) on page 1266 and [Positions Processing Steps](#) on page 1267 for a more detailed list of the processing steps in these groups.

The **Esko\_PlateID** is only used in the **Image to Screened Separations** task. See [Plate ID Processing Step](#) on page 1340.

**Structural Data Processing Steps**

Structural data processing steps are contours indicating how the printed product will be processed to make a 3D end product.

These include for example cutting, creasing and folding lines, and correspond to operations performed by finishing devices like die cutters, folder-glueers, etc.

This processing step type:	indicates:
Cutting	where the printed artwork will be cut from the printed sheet (for example with a guillotine cutter or die cutting device)
PartialCutting	where the substrate will be cut partially (not entirely through the material)
ReversePartialCutting	where the substrate will be cut partially (not entirely through the material) on the back side of the substrate
Creasing	where the substrate will be creased to guide subsequent folding
ReverseCreasing	where the substrate will be creased on the back side of the substrate
CuttingCreasing	where the substrate will undergo alternating cutting and creasing
ReverseCuttingCreasing	where the substrate will undergo alternating cutting and creasing on the back side of the substrate
PartialCuttingCreasing	where the substrate will undergo alternating partial cutting and creasing
ReversePartial-CuttingCreasing	where the substrate will undergo alternating partial cutting and creasing on the back side of the substrate
Drilling	locations where the substrate will be drilled, and the intended size of the resulting hole
Gluing	an area where glue will be applied



This processing step type:	indicates:
FoilStamping	an area where foil will be applied through hot foil stamping
ColdFoilStamping	an area where foil will be applied through cold foil stamping (using glue)
Embossing	an area where embossing will be applied
Debossing	an area where debossing will be applied
Perforating	where the substrate will be perforated
Bleed	the intended bleed for print
VarnishFree	an area where it is not allowed to have varnish
InkFree	an area where it is not allowed to have printing ink
InkVarnishFree	an area where it is not allowed to have printing ink or varnish
Folding	where the substrate will be folded without prior creasing
Punching	where the substrate will be punched, and the size and shape of the resulting holes
Stapling	where the substrate will be stapled or stitched, and the size of the staples or stitches to be used

### Positions Processing Steps

Positions processing steps are contours giving the position of certain graphic elements (for example where a barcode should be, or which area of a folding carton flap can be printed). They can also be used to indicate areas where graphic elements shouldn't be printed.

This processing step type:	indicates:
Hologram	the intended position of holograms
Barcode	the intended position of barcodes
ContentArea	areas where it is allowed to place text and other graphical elements
CodingMarking	<p>areas where additional information (not contained in the PDF) will be printed on the packaging at a post-press stage (such as on filling lines where the final products are being packed).</p> <p>These processing step objects are specific to packaging and can be used for lot numbers, production dates, best before dates, tracking codes...</p>
Imprinting	<p>areas where additional information will be printed in a secondary print stage (after most of the graphical content is already printed).</p> <p>This can be used to indicate the position of variable data for example.</p>

## Working with Processing Steps

### The Processing Steps tab

Imaging Engine and Pack Proof display the processing steps associated with the layers in your input file (or files placed in it) in the **Processing Steps** tab.

The list of processing steps that you see depends on various factors like the number of jobs you select, the input file type, etc.

If you select input files that are not PDF files	the <b>Processing Steps</b> tab will not be visible as processing steps are only applicable to PDF files  For example, for Normalized PDF files, the <b>Processing Steps</b> tab will always be hidden.
If you select only one job	only the processing steps of your job's printable layers are listed in the <b>Processing Steps</b> tab
If you select multiple jobs or if you don't select any job	all the processing steps supported by Imaging Engine and Pack Proof are listed
If your input file contains no layers	the processing steps tab will display an empty table with the "No printable processing steps found" message
If your input file contains layers that do not have equivalent processing steps in Imaging Engine/ Pack Proof	those layers will not be listed under this tab



**Note:** Adobe Illustrator layers can also be used as processing steps though they are not the same as PDF layers.

### Handling Processing Steps Content

By default, all processing steps are selected. This means that the processing steps data will be treated as regular content and go through the RIP. If an ink is only used by a processing step and that processing step is selected, Imaging Engine will output a separation for that ink.

If you don't want to output some processing step data (for example a cut line), deselect that processing step. You can also select or deselect a group: for example, deselect **Structural** to deselect all processing steps from that group.

Inks only used by deselected or non-printable processing steps will not be displayed in the **Inks** tab.

### Custom Processing Steps

You can add custom processing steps manually in the **Processing Steps** tab: use the **Add** button at the bottom of the tab (or the **Remove** button to remove a custom processing step).

This is useful if you want to use the same ticket with different selected/deselected processing steps for different files.



**Note:** You cannot add the same custom processing step twice.

## Inks

### Selecting Which Separations to Proof

Use the **Inks** settings to select which separations of the input file(s) you want to proof.

For example, you can use these settings to exclude technical and/or varnish inks from your output.

You can choose to proof either:

- **All** separations.
- A number of separations you select **Manually**.
- A number of separations you select **by using selection criteria**.

Selection criteria are rules that you define to select separations automatically for you when the task is launched on a file.

Selecting separations manually is the easiest option, but you can only do it on a file by file basis (when you launch the task on a single input file).

Using selection criteria is more advanced but also more powerful than selecting separations manually, and you can do it anytime (when launching the task on one or more input files, when using the task in a workflow, when defining ticket settings...).

Therefore, we recommend that you first try selecting separations manually when running the task on individual files, then switch to using selection criteria to automate your workflow further.

**Tip:**

To get used to working with selection criteria, try the following on a few of your files:

1. select the separations you want to output manually,
2. then change **Select Inks** to **by using selection criteria** and see which rules have been created based on your manual selection.

For more information, see [Selecting Inks Manually](#) on page 1270 and [Selecting Inks Using Selection Criteria](#) on page 1271.



**Tip:** You can also make the ink selection parameter public so that an operator can set it [through Shuttle](#) as needed for each job. See [Selecting Inks through Shuttle](#) on page 1274 for more information.

### Proofing Files with Unregistered Inks

Unregistered inks are inks that are not present in your [color management database](#), so there is no information about these inks apart from their RGB values in the input file.

If your input file contains [PantoneLIVE inks](#) and you don't have a PantoneLIVE license, those inks are also considered to be unregistered inks.

When [content proofing](#) with the **Proof for Content Approval** task, unregistered inks (and unlicensed PantoneLIVE inks) are output without making the task error, but their color on the proof may be inaccurate.



However, when you want to make a color managed proof with the [Image to Unscreened Proof](#) on page 1299 task, we recommend you replace all unregistered inks in your input file by inks from your color database before proofing.

### Selecting Inks Manually



**Note:** You can only select inks manually when you are launching the task on a (single) file, not when you are defining a generic ticket without an input file.

When choosing to **Select Inks Manually**, you will see a table containing all of your document's inks, showing each ink's:

<b>Ink Name</b>	
<b>Ink Book</b>	If an ink book is not present in your color database, it will show here as <unregistered "">.
<b>Ink Index</b>	<p>The <b>ink index</b> is the order in which the file's inks will be printed (the ink with ink index 1 is at the bottom of the document and will be printed first).</p> <p>If your file has several of the same ink, they will have the same ink index, and the next ink will have the next one (for example two Cyans will both have ink index 1, then Magenta will have ink index 2).</p> <p>This means that when selecting inks for processing, both Cyans will be selected together and handled the same way.</p> <div style="border: 1px solid #ccc; padding: 5px; margin-top: 10px;"> <p> <b>Tip:</b></p> <p>To find the ink index of a file:</p> <ol style="list-style-type: none"> <li>1. select the file in the Automation Engine Pilot's <b>Files</b> view,</li> <li>2. click ,</li> <li>3. in the <b>Info</b> dialog that opens, select <b>Inks</b> in the left panel.</li> </ol> <p>The order of the inks at right is the ink index (the topmost ink has an index of 1, the second of 2, etc.).</p> <p>Note that if you reorder the inks by one of the columns (for example by <b>ink name</b>), they won't be ordered by ink index anymore. You will need to close that dialog and reopen it to see the ink index order again.</p> </div>
<b>Spot Ink Index</b>	<p>The <b>Spot Ink index</b> is the order in which a spot ink will be printed (when counting only spot inks and not process inks).</p> <p>For example, if the first 4 inks of the document are CMYK, the first spot ink will have 5 as <b>ink index</b> but 1 as <b>Spot Ink Index</b>.</p> <p>As for the ink index, if your file has several of the same spot ink, they will have the same spot ink index, and will be handled together when you select them.</p>
<b>Ink Type</b>	This can be for example Normal, Technical, Varnish...
<b>Printing Method</b>	<p>If you have set a <b>Printing Method</b> for an ink it will be shown here (this can be for example Offset, Gravure, Flexo... or any custom printing method you configured).</p> <p>See the Automation Engine documentation for more information about printing methods.</p>

Select the ink(s) you want to proof, or select the toggle in the table header to select/deselect all inks.

### Selecting Inks Using Selection Criteria

If you don't want to [select inks manually](#) every time, you can define some rules to automatically select certain inks in your input file(s).

You can do this:

- either when running the task on one or more files, or when creating a task ticket to use later,
- by choosing to **Select Inks by using selection criteria** in the **Document Inks** settings.

#### How Does it Work?

You select the inks to be output by checking a combination of criteria:

1. You define what to check. You can check any of the following ink characteristics in your criteria:

<b>Ink name</b>	
<b>Ink book</b>	
<b>Ink index</b>	<p>The <b>Ink index</b> is the order in which the file's inks will be printed (the ink with ink index 1 is at the bottom of the document and will be printed first).</p> <p>To find the ink index of a file:</p> <ol style="list-style-type: none"> <li>1. select the file in the Automation Engine Pilot's <b>Files</b> view,</li> <li>2. click ,</li> <li>3. in the <b>Info</b> dialog that opens, select <b>Inks</b> in the left panel.</li> </ol> <p>The order of the inks at right is the ink index (the topmost ink has an index of 1, the second of 2, etc.).</p> <p>Note that if you reorder the inks by one of the columns (for example by <b>Ink name</b>), they won't be ordered by ink index anymore. You will need to close that dialog and reopen it to see the ink index order again.</p>
<b>Spot ink index</b>	<p>The <b>Spot ink index</b> is the order in which a spot ink will be printed (when counting only spot inks and not process inks).</p> <p>For example, if the first 4 inks of the document are CMYK, the first spot ink will have 5 as <b>Ink index</b> but 1 as <b>Spot ink index</b>.</p>
<b>Ink type</b>	This can be for example <i>Normal, Technical, Varnish...</i>
<b>Printing method</b>	<p>If you have set a <b>Printing method</b> for an ink it will be shown here (this can be for example <i>Offset, Gravure, Flexo...</i> or any custom printing method you configured).</p> <p>See the Automation Engine documentation for more information about printing methods.</p>

For example, you can check whether the **Ink book is** *process*, whether the **Ink name is** *yellow*...

You can use as many criteria as you want.

2. You define how to combine your criteria into a rule. For example:

- If you want to output only process yellow, you should check for inks that match **both** of the criteria:

**Ink book is** process  
**Ink name is** yellow

- If you want to output both all process inks and all yellow inks, you should check for inks that match **either** of the criteria:

**Ink book is** process  
**Ink name is** yellow

- If you don't want to output any process inks or any yellow inks, you should check for inks that match **neither** of the criteria:

**Ink book is** process  
**Ink name is** yellow

### How Do I Build Rules?

Build your rules the following way:

1. Choose how to combine the criteria in your rule:

- Select **All of the following are true** if you want to only select the inks that match **all** of the criteria you define.
- Select **Any of the following are true** if you want to select all the inks that match **at least one** of the criteria you define.
- Select **None of the following are true** if you want to only select the inks that match **none** of the criteria you define.

2. Define your first selection criterion.

You can select an ink based on its:

- **Ink name:** you can define if it **contains/begins with/ends with/is** a piece of text (alphanumerical characters), or if it **is empty**.
- **Ink book:** you can define if it **contains/begins with/ends with/is** a piece of text (alphanumerical characters), or if it **is empty**.
- **Ink index:** you can define if it **equals/is less than/is greater than** the number you enter, or is **is between** the two numbers you enter (in this case the ink indexes you enter as boundaries are also selected).
- **Spot ink index:** you can define if it **equals/is less than/is greater than** the number you enter, or is **is between** the two numbers you enter (in this case the spot ink indexes you enter as boundaries are also selected).
- **Ink type:** you can define if it **is** a piece of text (alphanumerical characters).
- **Printing method:** you can define if it **is** a piece of text (alphanumerical characters).

For example, you could use:	to:
<p><b>All of the following are true</b>  <b>Ink book is</b> <code>designer</code></p>	select all inks from the "designer" ink book
<p><b>None of the following are true</b>  <b>Ink name is</b> <code>crease</code></p>	exclude an ink called "crease"
<p><b>None of the following are true</b>  <b>Ink type is</b> <code>Technical</code>  <b>Ink type is</b> <code>Varnish</code></p>	exclude all technical and all varnish inks



**Tip:**

- You can enter several values to check for: just use a semicolon (;) between them. For example, to check for both inks called `Cyan` and inks called `Magenta`, choose **Ink name is** and enter `Cyan;Magenta`.
- When launching the task on a file, you can also click  to select one or more of the **Ink names/Ink books/Ink types/Printing methods** used in your input file(s). A criterion will automatically be created based on your selection.

3. Click + to add more criteria and define them.

To remove a criterion, click - next to it.



**Tip:** If you are launching the task on a single input file, you will see a table listing the **Selected document inks**, and another table with the **Document inks that are not selected** under the rules you defined.



**Attention:** If no ink is selected, you cannot launch the task.

### Switching How You Select Inks

You can switch between the two methods of selecting inks (*manually* and *using selection criteria*), and this will keep the same inks selected.

#### Switching from Selecting Inks Manually to Selecting Inks Using Selection Criteria

When switching from selecting inks manually to selecting inks using selection criteria, the task will translate your manual ink selection into rules, so that the same inks are selected (you can see them in the **Selected document inks** table).

The rules you get are based on the characteristics of the inks you selected.

For example, if you selected all the process colors but no spot color in your file, for an offset job, you will get the following rule:

**All of the following are true**

**Ink name is** `Cyan;Magenta;Yellow;Black`

**Ink book is** process  
**Ink type is** Normal  
**Printing method is** Offset



**Note:**

If you...

- first selected inks using selection criteria,
- then switched to manual selection without changing the selection,
- then switched back to selection criteria,

... then your rules will be kept.

If you did change the selection in manual mode, the task will automatically generate new rules.

**Switching from Selecting Inks Using Selection Criteria to Selecting Inks Manually**

When switching from selecting inks using selection criteria to selecting inks manually, all the inks selected by the rules you defined (the inks in the **Selected document inks** table) become selected manually.



**Note:** You can only switch to selecting inks manually when you are launching the task on a (single) file.

**Selecting Inks through Shuttle**

If you want to be able to decide which inks to proof when submitting your input file *through Shuttle*, do the following:

**In Your Imaging Engine Ticket**

1. To make the ink selection a public parameter, you can either:
  - Right-click **Select Inks** and choose **Make Parameter Public**.
  - If you (are currently launching the ticket on a file and) have chosen to *select inks manually*, right-click the preview table under **Select Inks** and choose **Make Parameter Public**.

Select Inks: Manually

<input type="checkbox"/>	Ink Name	Ink Book	Ink Index	Spot Ink Ind...	Ink Type	Printing Met...
<input type="checkbox"/>	Cyan	process	1	-	Normal	Unknown
<input type="checkbox"/>	Magenta	process	2	-	Normal	Unknown
<input type="checkbox"/>	Yellow	process	3	-	Normal	Unknown
<input type="checkbox"/>	Black	process	4	-	Normal	Unknown
<input type="checkbox"/>	crease	Visualizer St...	5	1	Technical	Unknown
<input type="checkbox"/>	Cut	<unregistere...	6	2	Technical	Unknown

- If you have chosen to *use selection criteria*, right-click the rules builder under **Select Inks** and choose **Make Parameter Public**.



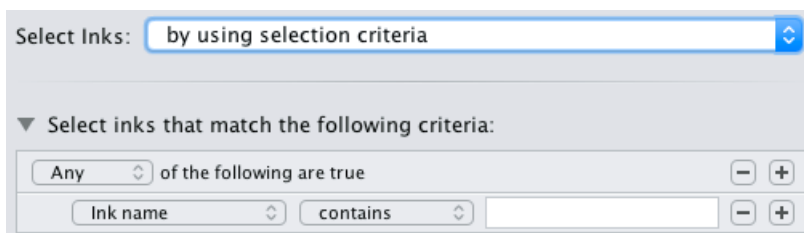

**Note:** You will not be able to create rules using Shuttle, you will only be able to select inks manually.

- Go to **Advanced > Manage Public Parameters...**, find the **Ink Selection** parameter at the bottom of the list, and drag it to the right hand side.

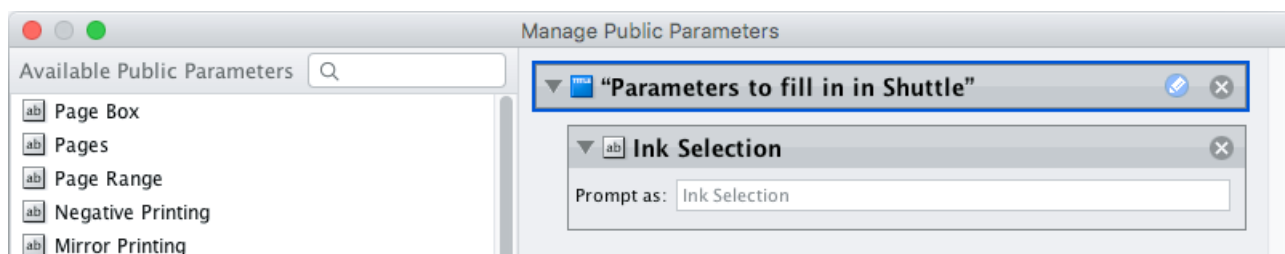

2. By default, the public parameter that appears in Shuttle will be called **Ink Selection**. You can change its name by:
  - right-clicking one of the elements mentioned above, selecting **Modify Public Parameter** and entering a new name,
  - if you are using the **Manage Public Parameters** window, entering the new name in **Prompt as**.
3. Make sure your ticket is also **Public**.

### In Shuttle

The ink selection parameter may look a bit different depending on which Shuttle you are using (the Shuttle standalone application or a Shuttle plug-in in an Editor application).

- In the Shuttle standalone, the ink selection parameter will look like this:

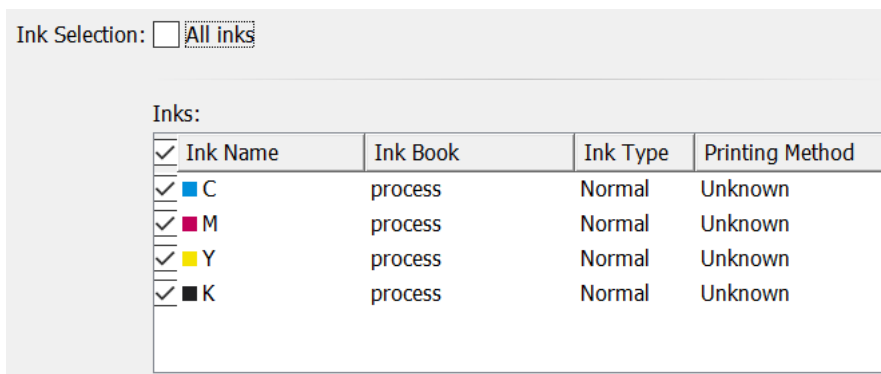

The table shows a preview of all inks in your input file, with their characteristics.

- To proof all inks from your input file, either leave all inks selected in the preview table, or select **All inks** at the top (this will hide the preview table).
- To only proof certain inks, make sure **All inks** is not selected, and deselect the input inks that you don't want to proof.
- In ArtPro+ for example, the ink selection parameter will look like this:

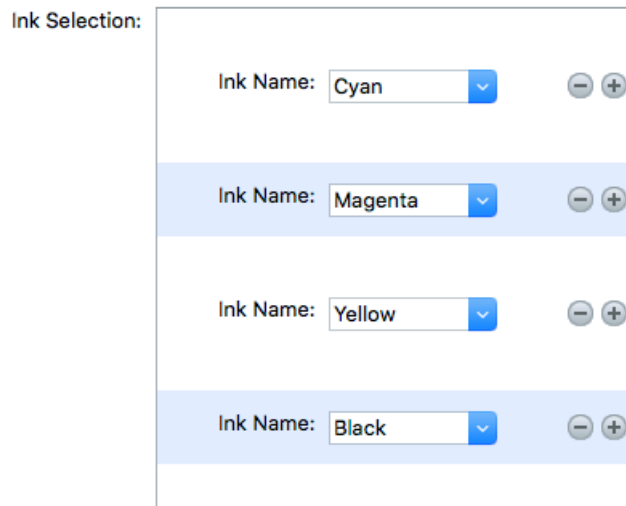

By default, all the inks from your input file will be proofed, but you can remove any ink you don't want to proof using the  button.

## Output

Use the **Output** settings to define how many copies of your proof you want, and whether to keep the files to proof them again later.

1. Enter the number of **Copies** you want to print (at least 1).

You can use SmartNames and/or public parameters.



**Tip:**

If the number of copies to print is already defined in your [Proof Server workflow](#), that number will be filled in by default.

You can of course change it as desired.

2. Select **Keep job files for relaunch purposes** if you want to be able to proof jobs a second time without having to RIP them again.

In this case, the files created for proofing will not be automatically cleaned up. When you don't need to keep them anymore, you will have to delete them manually from the `\\[Esko Proof Server]\ProofFolder` share.

You can set this option with a SmartName resolving to `true` to keep the files, or `false` to discard them.



**Note:**

To re-proof files that you have kept using this option, do the following:

1. Double-click the **Send to Proof Server** sub-task that was run on the job you want to reuse.
2. This reopens the ticket with a limited number of settings. Change your desired setting as necessary (for example the number of **Copies**).
3. Click **Launch**.

If you didn't select the **Keep job files for relaunch purposes**, you will see `The job cannot be reprinted as the files from the job were not kept when reopening the ticket.`

## Rendering

Use the **Rendering** settings to define how to handle images that have a different resolution than the output resolution, and set [other rendering options](#) to optimize your output.



**Note:**

Imaging Engine uses the output resolution defined in your [Proof Server workflow](#), where you need to decide whether quality or speed is more important to you.

- If you have chosen **High Quality** in your Proof Server workflow, Imaging Engine will output your file(s) at the maximum resolution supported by your proofing device (you can check this resolution in Fiery Command WorkStation, the Esko Proof Server's client application).  
You would typically use this for your final output, where quality is much more important than speed.
- If you have chosen **Standard** in your Proof Server workflow, Imaging Engine will output your file(s) at 50% of the maximum resolution supported by your proofing device.
- If you have chosen **Fast**, Imaging Engine will output your file(s) at 25% of the maximum resolution supported by your proofing device.

You would typically use this for drafts, where you don't need high quality yet but want a fast result.

For more information, please see the Esko Proof Server documentation, available from the [Pack Proof documentation page](#).

1. If your input file contains outlines, line art or contoured text, and you notice that they look too thick on print, we recommend you select the **Fine Line Rendering** option.

This will render objects with fine lines, for example Asian characters or barcodes, with a "thin fill".

You can set this option with a SmartName resolving to `true` to use **Fine Line Rendering** or `false` to use the standard rendering (also known as "fat fill").



**Note:**

If you have an older saved ticket (created in a version of Imaging Engine older than 22.11) with the outdated **Compensate for Outline Thickness** option selected, **Fine Line Rendering** will be used instead.

You will see a message about this:

- when opening the ticket,
- in the task details,
- in the log file.

When using this ticket, the task will end with a warning.

You can choose to not show this message again (in this case it won't be mentioned in the ticket, task details or log file, and the task won't end with a warning), but please note that this will apply to all users of that ticket.

2. If you experience problems with jagged edges, for example in small text, you can set an **Anti-aliasing** factor to smooth those edges.

See [Anti-Aliasing](#) on page 1188 for more information.

You can adjust the amount of anti-aliasing applied by choosing a factor of either 2, 3 or 4 (note that using a higher anti-aliasing factor may slow down processing).

You can also set this with a SmartName resolving to `None` (if you don't need anti-aliasing), or to the anti-aliasing factor you want (for example 2).



**Attention:** Because anti-aliasing changes the output sampling to smooth the jagged edges, you cannot resample your images (with the **Image Resampling** option) if you use anti-aliasing.

3. If needed, you can [resample](#) your images.

This is typically needed when the images' pixels don't map exactly to output pixels, for example if:

- the images' resolution is different from your chosen [output resolution](#),
- scaling and rotation effects change the size and placement of the images' pixels.

In the **Image Resampling** option, choose the resampling method you want to use:

- Choose **Auto Resampling** to upsample the images to an automatically calculated resolution (generally half or a third of the output resolution) before smoothing them.

When using this, images are a lot less pixellated and fuzzy.

This method takes some time but gives images of a good quality, so it is recommended in most cases.

You can also use a SmartName resolving to `ResampleAuto`.

- Choose **Full Resampling** to upsample the images to the full output resolution.

This method is the slowest, but gives the highest quality images (not pixellated and only slightly fuzzy).

You can also use a SmartName resolving to `ResampleFull`.

Use this if **Auto Resampling** doesn't give you the results you want.



**Attention:**

Resampling to full resolution can require significant amounts of memory when the output resolution is high (especially from 4000 dpi).

If you want to do this, we recommend that you have at least 8GB of RAM available for each worker (see the installation documentation).

- Choose **None** if you don't want to resample your input file's images.



**Note:**

If you upgraded from a previous version of Imaging Engine, in some cases you may have saved a ticket with a less optimal resampling method (**From File** or **PDF Interpolation**) in your older version. These methods are deprecated from Imaging Engine 18.1.1.

When processing a file with such a ticket, Imaging Engine will use the **Auto Resampling** method instead. You will get a warning about this.

4. If your input file is a Step and Repeat file, choose whether you want **Identical One-Ups**. This makes sure that on print, the details look the same in all your one-ups (see [Identical One-Ups](#) on page 1190 for more information).

- Select **On** if you want all one-ups of your input Step and Repeat files to look identical on print.



**Note:**

You can do this for the following input file types:

- **Plato** files (.pdfpla files or Normalized PDFs from Plato),
- Step and Repeat files in the Native PDF format (made by ArtPro+ or 3rd party software),
- Step and Repeat files in the ArtPro Classic file format (.ap or .art), if they were previously Normalized.



**Tip:**

If you were previously using FlexRip in combination with Plato, and setting the **Reset for each external file** option for **Screen Registration** in Plato, select **On** here to get a comparable result with Imaging Engine.

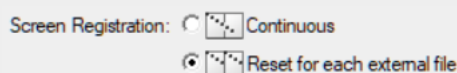

- Select **Off** if:
  - it is not important for you to have identical one-ups when doing Step and Repeat,
  - you are not currently working with Step and Repeat files or files with repeated placed art,

- if you are re-running a separation from an old job, and want your screens to match the previous run,
- you were satisfied with the screened output of previous versions of Imaging Engine that did not have this option (22.07 and older).

**Off** is selected by default. We recommend you leave it like this if you don't need identical one-ups, as rendering the one-ups identically can in some cases slow down your output.

- Select **Use from file** to use the information in your input Step and Repeat files to decide whether your one-ups need to be identical or not.

This is only applicable to Plato files with the **Screen Registration** parameter filled in.

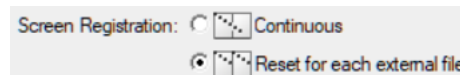

- If your input Plato file has the **Reset for each external file** option selected for the **Screen Registration** parameter, your one-ups will be aligned to the pixel grid to be made identical.
- If your input Plato file has the **Continuous** option selected for the **Screen Registration** parameter, your one-ups will be left as they are.

### Summary

This shows a summary of all the settings you defined in the ticket.

- To show the settings from a tab, click + (on PC) or ► (on Mac) beside the tab name in the right pane. Click **Expand All** to show the settings from all tabs.
- To hide the settings from a tab, click - (on PC) or ▼ (on Mac) beside the tab name in the right pane. Click **Collapse All** to hide the settings from all tabs.

## 16.5.2. Image to Content Proof (RGB)

Use the **Image to Content Proof (RGB)** task if you need a **high-resolution preview file**.

You can use this for **digital content proofing**, to check whether the contents of your file (layout, text, barcodes...) are correct. This is particularly useful in cases where a *physical content proof* would not be practical (for example if the customer is far away).

At that stage, you are typically not checking the color accuracy of your proof yet, so the **Image to Content Proof (RGB)** task only performs some default color management in the background (for preview purposes).

When you are satisfied with the content proof and want to make a contract proof with color management, you can use the *Image to Unscreened Proof* task.

### Task Output

The **Image to Content Proof (RGB)** task generates a high-resolution RGB preview file, in the *JPEG format*.

### Task Parameters

In the **Device** field, select the imaging device *that you configured*.

Then use the tabs at left to show more settings to fill in. See:

- [General](#) on page 1281,
- [Transformations](#) on page 1282,
- [PDF Objects](#) on page 1283,
- [Processing Steps](#) on page 1283
- [Inks](#) on page 1287,
- [File Output](#) on page 1295,
- [Summary](#) on page 1299.

### General

1. Define what **Page Box** of the input PDF you want to proof.

You can either select **Media Box**, **Trim Box**, or insert a SmartName `[]` that must resolve to either `media` or `trim`.

After selecting your file's page box you will see its dimensions under the **Page Box** option.

2. If your input file is a multi-page PDF, select which **Pages** you want to proof:

- a) First select **All pages**, **Odd pages only** or **Even pages only** in the **Pages** option.

You can also insert a SmartName resolving to either `All`, `Even` or `Odd`.

- b) Then you can refine your selection by entering page numbers or a **Page Range**.

You can separate page numbers by a comma, or use a dash to indicate a page range (for example `3, 6-9`). You can also use a SmartName resolving to page numbers and/or page ranges using this same format.



**Note:**

- Page numbers are always physical pages. If your document starts with page 5, you should not use 5 but 1 to get the first page.
- If you enter page numbers that are not part of your document, they will be excluded from the output (all the other valid pages will be proofed).
- If you enter the same page(s) more than once (for example `1, 1-2`), it/they will only be output once.
- Pages are proofed in the order of the document (entering `5-1` will be automatically changed to `1-5`).

3. If you want to invert your output so it is compatible with the output device or software system that will process it, click **A**.

You can also click `[]` or **Edit...** to insert a SmartName that must resolve to `1` or `true` (to invert the output), or to `0` or `false` (to leave the output as it is).



4. If you want to mirror your output so it is compatible with the output device or software system that will process it, click **M**.

You can also click **[ ]** or **Edit...** to insert a SmartName that must resolve to `1` or `true` (to mirror the output), or to `0` or `false` (to leave the output as it is).

## Transformations

Use the **Transformations** settings to scale or rotate your output relative to your input file.

1. Choose whether to **Scale** your input file's contents. Select either:

- **Scale by percent** and enter the vertical  and horizontal  scaling percentages to use (they must be between 10% and 1000%).



**Note:**

By default, you enter the vertical scaling percentage and the horizontal one is calculated automatically to keep the proportions.

If you want to enter the horizontal scaling percentage manually, click  to unlink it from the vertical one first.

However, if you do this then link the percentages again, the last percentage you entered will be kept, and the other one will be recalculated automatically to keep the proportions.

- **Do not scale** if you don't want to scale your file's contents.

You can use SmartNames resolving to `not` (**Do not scale**) or `ByPercent` (**Scale by percent**).

When entering SmartNames for vertical and horizontal scaling percentages, they must resolve to the numerical value (without the % sign).

2. If you want to rotate your file's contents, select the **Rotation** you want to apply here.

This can be:

- **0°**
- **90° Counter Clockwise**
- **180°**
- **90° Clockwise**

Any other value will give an error.



**Note:**

- You can use a SmartName that resolves to `0`, `90` (for **90° Counter Clockwise**), `180` or `270` (for **90° Clockwise**).
- You need to use a numerical value (`ninety` will not work).
- This is a public parameter, that you can fill in when submitting files through Shuttle.



## PDF Objects

1. If you experience issues with a font that doesn't look smooth enough at your selected resolution, your font may have **font hinting errors**.

Font hinting is the rendering of the outline (vectorized) font to pixels. For certain fonts, this rendering sometimes doesn't give a visually pleasing result, especially at low resolutions. In the image below, the top font has font hinting errors, the bottom font doesn't.



Label Pack  
Label Pack

Choose how to handle files containing font hinting errors:

- Leave **Task ends in error when the job contains font hinting errors** selected if you want the task to end in error when encountering font hinting errors. You can also use a SmartName resolving to `true`.
- Deselect **Task ends in error when the job contains font hinting errors** if you want to output your file anyway, whether it has font hinting errors or not (your task will end with a warning). You can also use a SmartName resolving to `false`.

This may lead to reduced quality rendering of the text, but it will not generate incorrect characters in your output file.

2. If your PDF+ input file has linked artwork and the external reference files have been modified, the changes do not get updated automatically in the PDF+ file. This will result in outdated data in the input as well as output files.

Choose how to handle files containing **outdated linked artwork**:

- Select **Task ends in error when linked artwork is not up to date** if you want the task to end in error if the input file contains outdated external references. You can also use a SmartName resolving to `true`.
- Deselect **Task ends in error when linked artwork is not up to date** if you want to output the file anyway, whether the references are outdated or not (your task will end with a warning). You can also use a SmartName resolving to `false`. This is the default option.

## Processing Steps

### What is a Processing Step?

PDF input files typically contain different types of objects, used at different stages of the production process: not only printable objects (that make up the design), but also other objects containing **post-processing data** (for example a cut path or crease lines).

Your production workflow needs to handle these object types accordingly.

If your customers, suppliers, etc. all define their post-processing data in their own way (for example a die cut path could be in a separation called "die" or "cut"), it can lead to:

- needing to make the production workflow more complex to catch all possibilities,
- loss of time,
- mistakes (possibly wasting plates or having a wrong print).

Imaging Engine and Pack Proof support the [ISO 19593 standard](#), that defines "**processing steps**" corresponding to different types of post-processing data. With input files that use these processing steps, you can work in a more uniform way, increasing efficiency and decreasing mistakes.

### Processing Step Groups

The **ISO 19593 standard** groups the different processing steps as follows:

#### Structural Data

Contours indicating how the printed product will be processed to make a 3D end product.

These include for example cutting, creasing and folding lines, and correspond to operations performed by finishing devices like die cutters, folder-glueers, etc.

#### Braille

Contours of objects representing braille content. The braille characters are made after printing, typically by a die cutter or inkjet device.

#### Legend

PDF objects outside the boundaries of the actual printed product (for example solid patches of the inks used in the design). They can contain job related data used in review, approval, and manual production steps.

#### Dimensions

These are also outside the printed area, and indicate the physical size of certain items in the design (using arrows, numbers and units).

#### Positions

Contours giving the position of certain graphic elements (for example where a barcode should be, or which area of a folding carton flap can be printed). They can also be used to indicate areas where graphic elements shouldn't be printed.

#### White

PDF objects indicating where the white backing ink (the opaque white ink used for white underprint on transparent or metallic substrates) will be on the design.

#### Varnish

PDF objects indicating where the varnish will go after printing.

Imaging Engine and Pack Proof also include the following custom processing steps groups by default:

#### **Esko\_PlateCutting**

Contours indicating how a flexo plate needs to be cut.

#### **Esko\_PlateID**

PDF objects containing information to identify the plate.



**Note:**

See [Structural Data Processing Steps](#) on page 1285 and [Positions Processing Steps](#) on page 1286 for a more detailed list of the processing steps in these groups.

The **Esko\_PlateID** is only used in the **Image to Screened Separations** task. See [Plate ID Processing Step](#) on page 1340.

**Structural Data Processing Steps**

Structural data processing steps are contours indicating how the printed product will be processed to make a 3D end product.

These include for example cutting, creasing and folding lines, and correspond to operations performed by finishing devices like die cutters, folder-glueers, etc.

This processing step type:	indicates:
Cutting	where the printed artwork will be cut from the printed sheet (for example with a guillotine cutter or die cutting device)
PartialCutting	where the substrate will be cut partially (not entirely through the material)
ReversePartialCutting	where the substrate will be cut partially (not entirely through the material) on the back side of the substrate
Creasing	where the substrate will be creased to guide subsequent folding
ReverseCreasing	where the substrate will be creased on the back side of the substrate
CuttingCreasing	where the substrate will undergo alternating cutting and creasing
ReverseCuttingCreasing	where the substrate will undergo alternating cutting and creasing on the back side of the substrate
PartialCuttingCreasing	where the substrate will undergo alternating partial cutting and creasing
ReversePartial-CuttingCreasing	where the substrate will undergo alternating partial cutting and creasing on the back side of the substrate
Drilling	locations where the substrate will be drilled, and the intended size of the resulting hole
Gluing	an area where glue will be applied
FoilStamping	an area where foil will be applied through hot foil stamping
ColdFoilStamping	an area where foil will be applied through cold foil stamping (using glue)
Embossing	an area where embossing will be applied
Debossing	an area where debossing will be applied
Perforating	where the substrate will be perforated
Bleed	the intended bleed for print
VarnishFree	an area where it is not allowed to have varnish
InkFree	an area where it is not allowed to have printing ink

This processing step type:	indicates:
InkVarnishFree	an area where it is not allowed to have printing ink or varnish
Folding	where the substrate will be folded without prior creasing
Punching	where the substrate will be punched, and the size and shape of the resulting holes
Stapling	where the substrate will be stapled or stitched, and the size of the staples or stitches to be used

**Positions Processing Steps**

Positions processing steps are contours giving the position of certain graphic elements (for example where a barcode should be, or which area of a folding carton flap can be printed). They can also be used to indicate areas where graphic elements shouldn't be printed.

This processing step type:	indicates:
Hologram	the intended position of holograms
Barcode	the intended position of barcodes
ContentArea	areas where it is allowed to place text and other graphical elements
CodingMarking	<p>areas where additional information (not contained in the PDF) will be printed on the packaging at a post-press stage (such as on filling lines where the final products are being packed).</p> <p>These processing step objects are specific to packaging and can be used for lot numbers, production dates, best before dates, tracking codes...</p>
Imprinting	<p>areas where additional information will be printed in a secondary print stage (after most of the graphical content is already printed).</p> <p>This can be used to indicate the position of variable data for example.</p>

**Working with Processing Steps**

**The Processing Steps tab**

Imaging Engine and Pack Proof display the processing steps associated with the layers in your input file (or files placed in it) in the **Processing Steps** tab.

The list of processing steps that you see depends on various factors like the number of jobs you select, the input file type, etc.

If you select input files that are not PDF files	<p>the <b>Processing Steps</b> tab will not be visible as processing steps are only applicable to PDF files</p> <p>For example, for Normalized PDF files, the <b>Processing Steps</b> tab will always be hidden.</p>
--------------------------------------------------	----------------------------------------------------------------------------------------------------------------------------------------------------------------------------------------------------------------------

If you select only one job	only the processing steps of your job's printable layers are listed in the <b>Processing Steps</b> tab
If you select multiple jobs or if you don't select any job	all the processing steps supported by Imaging Engine and Pack Proof are listed
If your input file contains no layers	the processing steps tab will display an empty table with the "No printable processing steps found" message
If your input file contains layers that do not have equivalent processing steps in Imaging Engine/ Pack Proof	those layers will not be listed under this tab



**Note:** Adobe Illustrator layers can also be used as processing steps though they are not the same as PDF layers.

### Handling Processing Steps Content

By default, all processing steps are selected. This means that the processing steps data will be treated as regular content and go through the RIP. If an ink is only used by a processing step and that processing step is selected, Imaging Engine will output a separation for that ink.

If you don't want to output some processing step data (for example a cut line), deselect that processing step. You can also select or deselect a group: for example, deselect **Structural** to deselect all processing steps from that group.

Inks only used by deselected or non-printable processing steps will not be displayed in the **Inks** tab.

### Custom Processing Steps

You can add custom processing steps manually in the **Processing Steps** tab: use the **Add** button at the bottom of the tab (or the **Remove** button to remove a custom processing step).

This is useful if you want to use the same ticket with different selected/deselected processing steps for different files.



**Note:** You cannot add the same custom processing step twice.

## Inks

### Selecting Which Separations to Proof

Use the **Inks** settings to select which separations of the input file(s) you want to proof.

For example, you can use these settings to exclude technical and/or varnish inks from your output.

You can choose to proof either:

- **All** separations.
- A number of separations you select **Manually**.
- A number of separations you select **by using selection criteria**.

Selection criteria are rules that you define to select separations automatically for you when the task is launched on a file.

Selecting separations manually is the easiest option, but you can only do it on a file by file basis (when you launch the task on a single input file).

Using selection criteria is more advanced but also more powerful than selecting separations manually, and you can do it anytime (when launching the task on one or more input files, when using the task in a workflow, when defining ticket settings...).

Therefore, we recommend that you first try selecting separations manually when running the task on individual files, then switch to using selection criteria to automate your workflow further.



**Tip:**

To get used to working with selection criteria, try the following on a few of your files:

1. select the separations you want to output manually,
2. then change **Select Inks** to **by using selection criteria** and see which rules have been created based on your manual selection.

For more information, see [Selecting Inks Manually](#) and [Selecting Inks Using Selection Criteria](#).



**Tip:** You can also make the ink selection parameter public so that an operator can set it [through Shuttle](#) as needed for each job. See [Selecting Inks through Shuttle](#) on page 1293 for more information.



### Selecting Inks Manually



**Note:** You can only select inks manually when you are launching the task on a (single) file, not when you are defining a generic ticket without an input file.

When choosing to **Select Inks Manually**, you will see a table containing all of your document's inks, showing each ink's:

<b>Ink Name</b>	
<b>Ink Book</b>	If an ink book is not present in your color database, it will show here as <unregistered "">.
<b>Ink Index</b>	<p>The <b>ink index</b> is the order in which the file's inks will be printed (the ink with ink index 1 is at the bottom of the document and will be printed first).</p> <p>If your file has several of the same ink, they will have the same ink index, and the next ink will have the next one (for example two Cyans will both have ink index 1, then Magenta will have ink index 2).</p> <p>This means that when selecting inks for processing, both Cyans will be selected together and handled the same way.</p>

	 <p><b>Tip:</b></p> <p>To find the ink index of a file:</p> <ol style="list-style-type: none"> <li>1. select the file in the Automation Engine Pilot's <b>Files</b> view,</li> <li>2. click ,</li> <li>3. in the <b>Info</b> dialog that opens, select <b>Inks</b> in the left panel.</li> </ol> <p>The order of the inks at right is the ink index (the topmost ink has an index of 1, the second of 2, etc.).</p> <p>Note that if you reorder the inks by one of the columns (for example by <b>Ink name</b>), they won't be ordered by ink index anymore. You will need to close that dialog and reopen it to see the ink index order again.</p>
<b>Spot Ink Index</b>	<p>The <b>Spot Ink index</b> is the order in which a spot ink will be printed (when counting only spot inks and not process inks).</p> <p>For example, if the first 4 inks of the document are CMYK, the first spot ink will have 5 as <b>Ink Index</b> but 1 as <b>Spot Ink Index</b>.</p> <p>As for the ink index, if your file has several of the same spot ink, they will have the same spot ink index, and will be handled together when you select them.</p>
<b>Ink Type</b>	<p>This can be for example <i>Normal, Technical, Varnish...</i></p>
<b>Printing Method</b>	<p>If you have set a <b>Printing Method</b> for an ink it will be shown here (this can be for example <i>Offset, Gravure, Flexo...</i> or any custom printing method you configured).</p> <p>See the Automation Engine documentation for more information about printing methods.</p>

Select the ink(s) you want to proof, or select the toggle in the table header to select/deselect all inks.

### Selecting Inks Using Selection Criteria

If you don't want to [select inks manually](#) every time, you can define some rules to automatically select certain inks in your input file(s).

You can do this:

- either when running the task on one or more files, or when creating a task ticket to use later,
- by choosing to **Select Inks by using selection criteria** in the **Document Inks** settings.

#### How Does it Work?

You select the inks to be output by checking a combination of criteria:

1. You define what to check. You can check any of the following ink characteristics in your criteria:

<b>Ink name</b>	
<b>Ink book</b>	
<b>Ink index</b>	<p>The <b>Ink index</b> is the order in which the file's inks will be printed (the ink with ink index 1 is at the bottom of the document and will be printed first).</p>

	<p>To find the ink index of a file:</p> <ol style="list-style-type: none"> <li>1. select the file in the Automation Engine Pilot's <b>Files</b> view,</li> <li>2. click ,</li> <li>3. in the <b>Info</b> dialog that opens, select <b>Inks</b> in the left panel.</li> </ol> <p>The order of the inks at right is the ink index (the topmost ink has an index of 1, the second of 2, etc.).</p> <p>Note that if you reorder the inks by one of the columns (for example by <b>Ink name</b>), they won't be ordered by ink index anymore. You will need to close that dialog and reopen it to see the ink index order again.</p>
<b>Spot ink index</b>	<p>The <b>Spot ink index</b> is the order in which a spot ink will be printed (when counting only spot inks and not process inks).</p> <p>For example, if the first 4 inks of the document are CMYK, the first spot ink will have 5 as <b>Ink index</b> but 1 as <b>Spot ink index</b>.</p>
<b>Ink type</b>	<p>This can be for example Normal, Technical, Varnish...</p>
<b>Printing method</b>	<p>If you have set a <b>Printing method</b> for an ink it will be shown here (this can be for example <i>Offset, Gravure, Flexo...</i> or any custom printing method you configured).</p> <p>See the Automation Engine documentation for more information about printing methods.</p>

For example, you can check whether the **Ink book is** process, whether the **Ink name is** yellow...

You can use as many criteria as you want.

2. You define how to combine your criteria into a rule. For example:

- If you want to output only process yellow, you should check for inks that match **both** of the criteria:

**Ink book is** process  
**Ink name is** yellow

- If you want to output both all process inks and all yellow inks, you should check for inks that match **either** of the criteria:

**Ink book is** process  
**Ink name is** yellow

- If you don't want to output any process inks or any yellow inks, you should check for inks that match **neither** of the criteria:

**Ink book is** process  
**Ink name is** yellow

**How Do I Build Rules?**

Build your rules the following way:

1. Choose how to combine the criteria in your rule:

- Select **All of the following are true** if you want to only select the inks that match **all** of the criteria you define.



- Select **Any of the following are true** if you want to select all the inks that match **at least one** of the criteria you define.
  - Select **None of the following are true** if you want to only select the inks that match **none** of the criteria you define.
2. Define your first selection criterion.

You can select an ink based on its:

- **Ink name:** you can define if it **contains/begins with/ends with/is** a piece of text (alphanumerical characters), or if it **is empty**.
- **Ink book:** you can define if it **contains/begins with/ends with/is** a piece of text (alphanumerical characters), or if it **is empty**.
- **Ink index:** you can define if it **equals/is less than/is greater than** the number you enter, or **is between** the two numbers you enter (in this case the ink indexes you enter as boundaries are also selected).
- **Spot ink index:** you can define if it **equals/is less than/is greater than** the number you enter, or **is between** the two numbers you enter (in this case the spot ink indexes you enter as boundaries are also selected).
- **Ink type:** you can define if it **is** a piece of text (alphanumerical characters).
- **Printing method:** you can define if it **is** a piece of text (alphanumerical characters).

For example, you could use:	to:
<b>All of the following are true</b> <b>Ink book is</b> designer	select all inks from the "designer" ink book
<b>None of the following are true</b> <b>Ink name is</b> crease	exclude an ink called "crease"
<b>None of the following are true</b> <b>Ink type is</b> Technical <b>Ink type is</b> Varnish	exclude all technical and all varnish inks



**Tip:**

- You can enter several values to check for: just use a semicolon (;) between them.  
For example, to check for both inks called Cyan and inks called Magenta, choose **Ink name is** and enter Cyan;Magenta.
- When launching the task on a file, you can also click  to select one or more of the **Ink names/Ink books/Ink types/Printing methods** used in your input file(s).  
A criterion will automatically be created based on your selection.

3. Click + to add more criteria and define them.

To remove a criterion, click - next to it.



**Tip:** If you are launching the task on a single input file, you will see a table listing the **Selected document inks**, and another table with the **Document inks that are not selected** under the rules you defined.



**Attention:** If no ink is selected, you cannot launch the task.

### Switching How You Select Inks

You can switch between the two methods of selecting inks (*manually* and *using selection criteria*), and this will keep the same inks selected.

#### Switching from Selecting Inks Manually to Selecting Inks Using Selection Criteria

When switching from selecting inks manually to selecting inks using selection criteria, the task will translate your manual ink selection into rules, so that the same inks are selected (you can see them in the **Selected document inks** table).

The rules you get are based on the characteristics of the inks you selected.

For example, if you selected all the process colors but no spot color in your file, for an offset job, you will get the following rule:

**All of the following are true**

**Ink name is** Cyan;Magenta;Yellow;Black

**Ink book is** process

**Ink type is** Normal

**Printing method is** Offset



**Note:**

If you...

- first selected inks using selection criteria,
- then switched to manual selection without changing the selection,
- then switched back to selection criteria,

... then your rules will be kept.

If you did change the selection in manual mode, the task will automatically generate new rules.

#### Switching from Selecting Inks Using Selection Criteria to Selecting Inks Manually

When switching from selecting inks using selection criteria to selecting inks manually, all the inks selected by the rules you defined (the inks in the **Selected document inks** table) become selected manually.



**Note:** You can only switch to selecting inks manually when you are launching the task on a (single) file.







### Selecting Inks through Shuttle

If you want to be able to decide which inks to proof when submitting your input file *through Shuttle*, do the following:

#### In Your Imaging Engine Ticket

1. To make the ink selection a public parameter, you can either:
  - Right-click **Select Inks** and choose **Make Parameter Public**.
  - If you (are currently launching the ticket on a file and) have chosen to *select inks manually*, right-click the preview table under **Select Inks** and choose **Make Parameter Public**.

Select Inks: Manually

<input type="checkbox"/>	Ink Name	Ink Book	Ink Index	Spot Ink Ind...	Ink Type	Printing Met...
<input type="checkbox"/>	 Cyan	process	1	-	Normal	Unknown
<input type="checkbox"/>	 Magenta	process	2	-	Normal	Unknown
<input type="checkbox"/>	 Yellow	process	3	-	Normal	Unknown
<input type="checkbox"/>	 Black	process	4	-	Normal	Unknown
<input type="checkbox"/>	 crease	Visualizer St...	5	1	Technical	Unknown
<input type="checkbox"/>	 Cut	<unregistre...	6	2	Technical	Unknown

- If you have chosen to *use selection criteria*, right-click the rules builder under **Select Inks** and choose **Make Parameter Public**.

Select Inks: by using selection criteria

▼ Select inks that match the following criteria:

Any of the following are true

Ink name contains



**Note:** You will not be able to create rules using Shuttle, you will only be able to select inks manually.

- Go to **Advanced > Manage Public Parameters...**, find the **Ink Selection** parameter at the bottom of the list, and drag it to the right hand side.

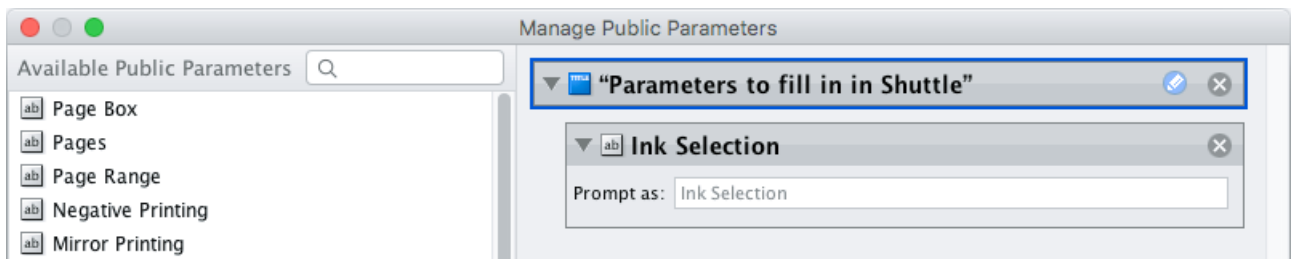

2. By default, the public parameter that appears in Shuttle will be called **Ink Selection**. You can change its name by:
  - right-clicking one of the elements mentioned above, selecting **Modify Public Parameter** and entering a new name,
  - if you are using the **Manage Public Parameters** window, entering the new name in **Prompt as**.
3. Make sure your ticket is also **Public**.

### In Shuttle

The ink selection parameter may look a bit different depending on which Shuttle you are using (the Shuttle standalone application or a Shuttle plug-in in an Editor application).

- In the Shuttle standalone, the ink selection parameter will look like this:

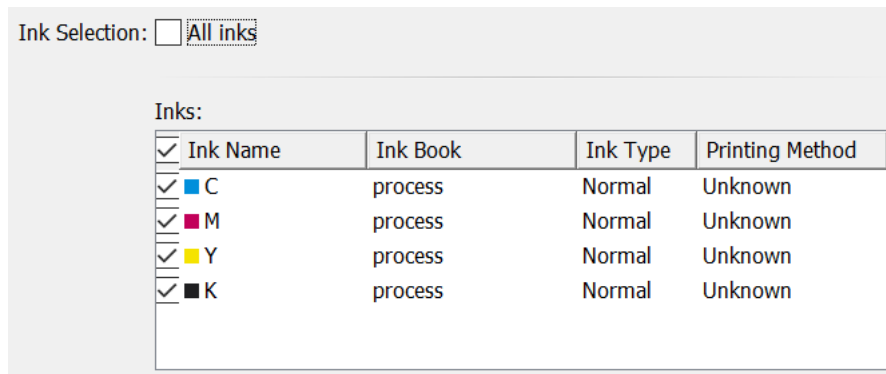

The table shows a preview of all inks in your input file, with their characteristics.

- To proof all inks from your input file, either leave all inks selected in the preview table, or select **All inks** at the top (this will hide the preview table).
- To only proof certain inks, make sure **All inks** is not selected, and deselect the input inks that you don't want to proof.
- In ArtPro+ for example, the ink selection parameter will look like this:

Ink Selection:

Ink Name:	Cyan	▼	⊖	⊕
Ink Name:	Magenta	▼	⊖	⊕
Ink Name:	Yellow	▼	⊖	⊕
Ink Name:	Black	▼	⊖	⊕

By default, all the inks from your input file will be proofed, but you can remove any ink you don't want to proof using the ⊖ button.

### File Output

Use the **File Output** settings to define what type of output you want and where to output it.

You can set these through public parameters or using SmartNames.

1. Enter your output **File Name** and output **Folder**.



**Note:**

- You can use Imaging Engine-specific SmartNames for the **File Name**.  
By default, it is set to:
  - [File] for single page input files (which gives output file names like Myfile.jpg),
  - [File]\_p[Page] for multi-page input files (which gives output file names like Myfile\_p1.jpg).
- The **File Name** and **Folder** can contain special characters (except \ / : \* ? < > " |).
- The whole path to the output file (including the container, **Folder** and **File Name**) can be up to 255 characters.
- You can set a local or remote URL for the output **Folder**, but it must be an absolute path.
- If your output folder doesn't exist yet, the task will create it if the location you request is valid (you should place this folder on an Automation Engine container accessible by your Automation Engine user).

If the output folder creation fails, please check the task log for the full list of conditions and adapt your output folder path accordingly.

2. Define what to do if a file of the same name already exists in your output folder:

a) Click **Set Overwrite Policy...**

b) Choose what to do **If files exist already**. You can either:

- **Extend the file name** if you want to keep the existing output file and give the new output file a different name. In this case, your new output file name consists of:
  - the **Output file name** (the **File Name** you set earlier) - which is what the file would be called if no file with the same name existed,
  - a custom suffix that you can define using plain text and/or SmartNames (by default, this is `_c`, for "copy"),
  - an automatic suffix made of the three last digits of the task **ID**,



**Tip:**

To see the task ID of your tasks:

1. Go to the Pilot's **Tasks** pane (in the **Files** or **Tasks** view).
2. Go to **View > Select Columns in 'Tasks'...**
3. In the **Columns** dialog, select **Task ID** in the **Available columns** list and click  to move it to the **Show these columns:** list.
4. Click **OK**.
5. You now have a **Task ID** column in the **Tasks** pane, listing the task ID of all the tasks.

- the file extension.

For example, your input file is called `file.pdf` and you have left the tasks' output **File Name** to its default value (the SmartName **[File]**).

The first JPEG you generate will be called `file.jpg`.

If you generate output from this input file again, with the task 3668, and you have set the overwrite policy to **Extend the file name** with the default **Output File Name + \_c + ID** name, the new output file will be called `file_c668.jpg`

- **Overwrite** the existing file(s).
- **End the task in error**.



**Note:** If you use a SmartName to set this, it must resolve to `extend` or 0 (for **Extend the file name**), `overwrite` or 1 (for **Overwrite**), or `error` or 2 (for **End the task in error**).

c) Click **Set**.

3. The output **File Type** is always a **JPEG File**.

See [File Formats](#) on page 1224 for more information.

4. Choose the **Compression** to use for your output file(s).

You should choose a compression method based on the compression speed and the compressed file size. Typically, faster compression methods compress the file less, so the output file is bigger.

They are sorted from very high compression, which reduces the file size a lot but loses a lot of detail (**JPEG Limited Quality**), to very low compression, which doesn't lose much detail but doesn't reduce the file size much (**JPEG Extreme Quality**).



**Attention:**

When using a SmartName to set the output file's **Compression**, it must resolve to one of the following (case insensitive): **JPEGLimited**, **JPEGLow**, **JPEGStandardLow**, **JPEGStandard**, **JPEGStandardHigh**, **JPEGHigh**, or **JPEGExtreme**.

Setting any other value will make the task error.

## Rendering

Use the **Rendering** settings to set the output resolution and *other rendering options* to optimize your output.

1. Set the **Resolution** of your output files.



**Note:**

- The **Resolution** unit is taken from the general Automation Engine Preferences.
- You can enter values from 1 to 25400 ppi (or equivalent in your unit). SmartNames must also resolve to a value in that range.
- Values in another unit than the one from the general Preferences will be recalculated, and values like 300ppi + 500ppm will be calculated correctly.

2. If your input file contains outlines, line art or contoured text, and you notice that they look too thick on print, we recommend you select the **Fine Line Rendering** option.

This will render objects with fine lines, for example Asian characters or barcodes, with a "thin fill".

You can set this option with a SmartName resolving to `true` to use **Fine Line Rendering** or `false` to use the standard rendering (also known as "fat fill").



**Note:**

If you have an older saved ticket (created in a version of Imaging Engine older than 22.11) with the outdated **Compensate for Outline Thickness** option selected, **Fine Line Rendering** will be used instead.

You will see a message about this:

- when opening the ticket,
- in the task details,
- in the log file.

When using this ticket, the task will end with a warning.

You can choose to not show this message again (in this case it won't be mentioned in the ticket, task details or log file, and the task won't end with a warning), but please note that this will apply to all users of that ticket.

3. If you experience problems with jagged edges, for example in small text, you can set an **Anti-aliasing** factor to smooth those edges.

See [Anti-Aliasing](#) on page 1188 for more information.

You can adjust the amount of anti-aliasing applied by choosing a factor of either 2, 3 or 4 (note that using a higher anti-aliasing factor may slow down processing).

You can also set this with a SmartName resolving to `None` (if you don't need anti-aliasing), or to the anti-aliasing factor you want (for example 2).

4. If your input file is a Step and Repeat file, choose whether you want **Identical One-Ups**. This makes sure that on print, the details look the same in all your one-ups (see [Identical One-Ups](#) on page 1190 for more information).
  - Select **On** if you want all one-ups of your input Step and Repeat files to look identical on print.



**Note:**

You can do this for the following input file types:

- [Plato](#) files (.pdfpla files or Normalized PDFs from Plato),
- Step and Repeat files in the Native PDF format (made by ArtPro+ or 3rd party software),
- Step and Repeat files in the ArtPro Classic file format (.ap or .art), if they were previously Normalized.



**Tip:**

If you were previously using FlexRip in combination with Plato, and setting the **Reset for each external file** option for **Screen Registration** in Plato, select **On** here to get a comparable result with Imaging Engine.

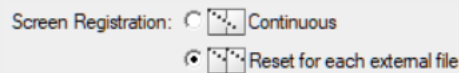

- Select **Off** if:
  - it is not important for you to have identical one-ups when doing Step and Repeat,
  - you are not currently working with Step and Repeat files or files with repeated placed art,
  - if you are re-running a separation from an old job, and want your screens to match the previous run,
  - you were satisfied with the screened output of previous versions of Imaging Engine that did not have this option (22.07 and older).

**Off** is selected by default. We recommend you leave it like this if you don't need identical one-ups, as rendering the one-ups identically can in some cases slow down your output.

- Select **Use from file** to use the information in your input Step and Repeat files to decide whether your one-ups need to be identical or not.

This is only applicable to Plato files with the **Screen Registration** parameter filled in.



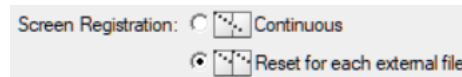

- If your input Plato file has the **Reset for each external file** option selected for the **Screen Registration** parameter, your one-ups will be aligned to the pixel grid to be made identical.
- If your input Plato file has the **Continuous** option selected for the **Screen Registration** parameter, your one-ups will be left as they are.

### Summary

This shows a summary of all the settings you defined in the ticket.

- To show the settings from a tab, click + (on PC) or ► (on Mac) beside the tab name in the right pane. Click **Expand All** to show the settings from all tabs.
- To hide the settings from a tab, click - (on PC) or ▼ (on Mac) beside the tab name in the right pane. Click **Collapse All** to hide the settings from all tabs.

### 16.5.3. Image to Unscreened Proof

You can use the **Image to Unscreened Proof** task for **contract proofing**. You typically make a **contract proof** once you are satisfied with the *physical* or *digital* content proof.

At the contract proof stage, you *color manage* your job to ensure that your proof is as color accurate as possible, then send it to your customer for final approval before printing.



**Tip:**

If you also want to unquestionably **verify** the color accuracy of your proof against your customer's criteria when **contract proofing**, we recommend you use **Pack Proof** together with Imaging Engine.

See the [Pack Proof documentation](#) for more information.

### Task Output

The **Image to Unscreened Proof** task generates unscreened but color managed output, in a file that you can send to a proofer. You can choose to output separated TIFF files, or composite *TIFF, PDF or JPEG files* (one file with all the separations).

In the example below, processing a file containing the lime green Esko star generates one multi-channel unscreened file containing the Cyan, Yellow, Magenta and Black channels, where the Magenta channel is empty.

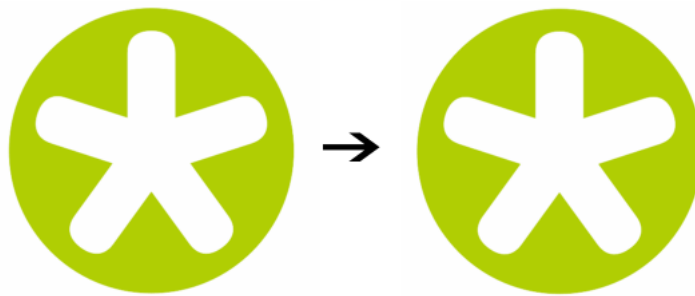

### Task Parameters

In the **Device** field, select the imaging device *that you configured*.

Then use the tabs at left to show more settings to fill in. See:

- [General](#) on page 1300,
- [Proofer](#) on page 1302,
- [Transformations](#) on page 1302,
- [PDF Objects](#) on page 1303,
- [Processing Steps](#) on page 1305
- [Inks](#) on page 1309,
- [Color Management](#) on page 1317,
- [File Output](#) on page 1321,
- [Summary](#) on page 1329.

### General

1. Define what **Page Box** of the input PDF you want to proof.

You can either select **Media Box**, **Trim Box**, or insert a SmartName `{}` that must resolve to either `media` or `trim`.

After selecting your file's page box you will see its dimensions under the **Page Box** option.

2. If your input file is a multi-page PDF, select which **Pages** you want to proof:

- a) First select **All pages**, **Odd pages only** or **Even pages only** in the **Pages** option.

You can also insert a SmartName resolving to either `All`, `Even` or `Odd`.

- b) Then you can refine your selection by entering page numbers or a **Page Range**.

You can separate page numbers by a comma, or use a dash to indicate a page range (for example `3, 6-9`). You can also use a SmartName resolving to page numbers and/or page ranges using this same format.



**Note:**

- Page numbers are always physical pages. If your document starts with page 5, you should not use 5 but 1 to get the first page.
- If you enter page numbers that are not part of your document, they will be excluded from the output (all the other valid pages will be proofed).
- If you enter the same page(s) more than once (for example 1, 1-2), it/they will only be output once.
- Pages are proofed in the order of the document (entering 5-1 will be automatically changed to 1-5).

3. If you want to invert your output so it is compatible with the output device or software system that will process it, click **A**.

You can also click **I** or **Edit...** to insert a SmartName that must resolve to 1 or `true` (to invert the output), or to 0 or `false` (to leave the output as it is).

4. If you want to mirror your output so it is compatible with the output device or software system that will process it, click **M**.

You can also click **I** or **Edit...** to insert a SmartName that must resolve to 1 or `true` (to mirror the output), or to 0 or `false` (to leave the output as it is).

5. If you want to add **SmartMarks (Classic)** or **Dynamic Marks** in your output file(s), select the **Type of Marks** you want to add and then select the specific **Mark Set** you want to use.

**SmartMarks (Classic)** or **Dynamic Marks** are marks whose content is variable, so you can make them display information about that specific job and use them as a production control. For example, you can include some of the parameters used during RIP'ing in your output file(s) by using SmartMarks (Classic) or Dynamic Marks.

You need to:

- a) First create the SmartMarks (Classic) you want to use in **PackEdge** or **Plato** and the Dynamic Marks in **ArtPro+** (see the PackEdge, Plato and Arpro+ manuals for more details).

You can create either:

- a general SmartMark (Classic) or Dynamic Mark (for example a corner mark or split mark),
- a Text Mark with Smart Text, that will display the information included in your input file,
- an Imaging Engine-specific Text Mark with Smart Text, that will display the parameters that you set in the ticket.

To do this, select **Output Parameter** in the **Smart Text** pop-up in the PackEdge/ArtPro+ application. Make sure you use the RIP-related SmartMark attributes from the **Output Parameter** category, and not those from the **Ink/Color** category.

If your PackEdge, Plato or ArtPro+ application is linked to your Automation Engine server, your SmartMarks (Classic) or Dynamic Marks will automatically be saved in the correct location and will be available in Imaging Engine.

- b) Then select that SmartMark (Classic) or Dynamic Mark in your **Imaging Engine task** using the **Mark Set** option.

The SmartMarks (Classic) or Dynamic Marks will be added to each output file generated from your input file.

## Proofer

If you already know the **Substrate Size** you will proof your output files on, select it here.



**Tip:** The size you select here can be used to scale the input file's contents to the substrate automatically (to do this, select **Fit to page size** or **Fit to page width** in the [Transformations tab](#)).

- You can either:
  - Select your **Substrate Size** from a list of predefined sizes.
  - Enter the substrate's **Width** and **Height** yourself to define a **Custom** substrate.



**Note:**

- By default, the **Substrate Size** is set to **Custom**, with the **Width** and **Height** values of an A3 page.
- The **Width** and **Height** unit is taken from the general Automation Engine Preferences.

You can set those values using public parameters and/or SmartNames. If you use SmartNames, make sure that:



- the SmartName for **Substrate Size** resolves to one of the substrate sizes offered in the list (when using a SmartName here, the **Width** and **Height** options will show **0**, but the task will use the correct dimensions when it runs).
- the SmartNames for **Width** and **Height** resolve to a numerical value, without any unit (the default task unit, mm, will then be used, regardless of the unit set in the general Automation Engine Preferences). When using a SmartName in one or both of these options, the **Substrate Size** will show **Custom**.

If one or more of the SmartNames resolves to an invalid value, the task will fail.

## Transformations

Use the **Transformations** settings to scale or rotate your output relative to your input file.

- If you want to **Scale** your input file's contents, select either:

- Scale by percent** and enter the vertical  and horizontal  scaling percentages to use (they must be between 10% and 1000%).



**Note:**

By default, you enter the vertical scaling percentage and the horizontal one is calculated automatically to keep the proportions.

If you want to enter the horizontal scaling percentage manually, click  to unlink it from the vertical one first.

However, if you do this then link the percentages again, the last percentage you entered will be kept, and the other one will be recalculated automatically to keep the proportions.

- **Fit to page size** to fit your output to the substrate you defined in the [Proofer settings](#), while keeping the proportions (this will fit it to either the width or the height of the substrate, while making sure everything is on the substrate).
- **Fit to page width** to fit it to the width of the substrate you defined in the [Proofer settings](#), while keeping the proportions.

If you [added SmartMarks](#) to your output, they will be taken into account when fitting the proof file to the substrate's width or size.

If you don't want to scale your file's contents, leave **Do not scale** selected.

You can use SmartNames resolving to `not` (**Do not scale**), `ByPercent` (**Scale by percent**), `FitSize` (**Fit to page size**) or `FitWidth` (**Fit to page width**).

When entering SmartNames for vertical and horizontal scaling percentages, they must resolve to the numerical value (without the % sign).

2. If you want to rotate your file's contents, select the **Rotation** you want to apply here.

This can be:

- **0°**
- **90° Counter Clockwise**
- **180°**
- **90° Clockwise**

Any other value will give an error.



**Note:**

- You can use a SmartName that resolves to 0, 90 (for **90° Counter Clockwise**), 180 or 270 (for **90° Clockwise**).
- You need to use a numerical value (`ninety` will not work).
- This is a public parameter, that you can fill in when submitting files through Shuttle.

## PDF Objects

Use the **PDF Objects** settings to define:

- how to color manage RGB objects in your input file,
- what dot gain compensation to apply to your input file's images.

All parameters in this tab are public parameters, that you can fill in when submitting files through Shuttle.

1. In **Default RGB Profile**, specify the profile to use if no profile is specified for a certain RGB object in the input file. The default is `srgb.icc`.

You can use a SmartName that resolves to the full profile name.

2. Select **Use PDF transfer curves** if you want to use:
  - the *Dot Gain Compensation curves* attached to the images in your input PDF. These curves compensate for the unwanted characteristics of the device that created the images (scanner, digital camera...).
  - the **Color Correction curves** added by ArtPro+ version 20 and higher. These curves allow you to correct individual separations for color deviations on proof from the reference proof. The correction will be applied on both the proof and the production files.



**Note:**

You can only use the correction curves if the Color Correction curves option is enabled in the global Imaging Engine configuration.

Please contact Esko Support for assistance.

You can use a SmartName that resolves to `true` (to use the input file's curves) or `false` (to not use them).

3. If you experience issues with a font that doesn't look smooth enough at your selected resolution, your font may have **font hinting errors**.

Font hinting is the rendering of the outline (vectorized) font to pixels. For certain fonts, this rendering sometimes doesn't give a visually pleasing result, especially at low resolutions. In the image below, the top font has font hinting errors, the bottom font doesn't.

Label Pack  
Label Pack

Choose how to handle files containing font hinting errors:

- Leave **Task ends in error when the job contains font hinting errors** selected if you want the task to end in error when encountering font hinting errors. You can also use a SmartName resolving to `true`.
- Deselect **Task ends in error when the job contains font hinting errors** if you want to output your file anyway, whether it has font hinting errors or not (your task will end with a warning). You can also use a SmartName resolving to `false`.

This may lead to reduced quality rendering of the text, but it will not generate incorrect characters in your output file.

4. If your PDF+ input file has linked artwork and the external reference files have been modified, the changes do not get updated automatically in the PDF+ file. This will result in outdated data in the input as well as output files.

Choose how to handle files containing **outdated linked artwork**:

- Select **Task ends in error when linked artwork is not up to date** if you want the task to end in error if the input file contains outdated external references. You can also use a SmartName resolving to `true`.
- Deselect **Task ends in error when linked artwork is not up to date** if you want to output the file anyway, whether the references are outdated or not (your task will end with a warning). You can also use a SmartName resolving to `false`. This is the default option.

## Processing Steps

### What is a Processing Step?

PDF input files typically contain different types of objects, used at different stages of the production process: not only printable objects (that make up the design), but also other objects containing **post-processing data** (for example a cut path or crease lines).

Your production workflow needs to handle these object types accordingly.

If your customers, suppliers, etc. all define their post-processing data in their own way (for example a die cut path could be in a separation called "die" or "cut"), it can lead to:

- needing to make the production workflow more complex to catch all possibilities,
- loss of time,
- mistakes (possibly wasting plates or having a wrong print).

Imaging Engine and Pack Proof support the [ISO 19593 standard](#), that defines "**processing steps**" corresponding to different types of post-processing data. With input files that use these processing steps, you can work in a more uniform way, increasing efficiency and decreasing mistakes.

### Processing Step Groups

The **ISO 19593 standard** groups the different processing steps as follows:

#### Structural Data

Contours indicating how the printed product will be processed to make a 3D end product.

These include for example cutting, creasing and folding lines, and correspond to operations performed by finishing devices like die cutters, folder-glueers, etc.

#### Braille

Contours of objects representing braille content. The braille characters are made after printing, typically by a die cutter or inkjet device.

#### Legend

PDF objects outside the boundaries of the actual printed product (for example solid patches of the inks used in the design). They can contain job related data used in review, approval, and manual production steps.

**Dimensions**

These are also outside the printed area, and indicate the physical size of certain items in the design (using arrows, numbers and units).

**Positions**

Contours giving the position of certain graphic elements (for example where a barcode should be, or which area of a folding carton flap can be printed). They can also be used to indicate areas where graphic elements shouldn't be printed.

**White**

PDF objects indicating where the white backing ink (the opaque white ink used for white underprint on transparent or metallic substrates) will be on the design.

**Varnish**

PDF objects indicating where the varnish will go after printing.

Imaging Engine and Pack Proof also include the following custom processing steps groups by default:

**Esko\_PlateCutting**

Contours indicating how a flexo plate needs to be cut.

**Esko\_PlateID**

PDF objects containing information to identify the plate.



**Note:**

See [Structural Data Processing Steps](#) on page 1306 and [Positions Processing Steps](#) on page 1307 for a more detailed list of the processing steps in these groups.

The **Esko\_PlateID** is only used in the **Image to Screened Separations** task. See [Plate ID Processing Step](#) on page 1340.

**Structural Data Processing Steps**

Structural data processing steps are contours indicating how the printed product will be processed to make a 3D end product.

These include for example cutting, creasing and folding lines, and correspond to operations performed by finishing devices like die cutters, folder-glueers, etc.

This processing step type:	indicates:
Cutting	where the printed artwork will be cut from the printed sheet (for example with a guillotine cutter or die cutting device)
PartialCutting	where the substrate will be cut partially (not entirely through the material)
ReversePartialCutting	where the substrate will be cut partially (not entirely through the material) on the back side of the substrate
Creasing	where the substrate will be creased to guide subsequent folding
ReverseCreasing	where the substrate will be creased on the back side of the substrate
CuttingCreasing	where the substrate will undergo alternating cutting and creasing



This processing step type:	indicates:
ReverseCuttingCreasing	where the substrate will undergo alternating cutting and creasing on the back side of the substrate
PartialCuttingCreasing	where the substrate will undergo alternating partial cutting and creasing
ReversePartial-CuttingCreasing	where the substrate will undergo alternating partial cutting and creasing on the back side of the substrate
Drilling	locations where the substrate will be drilled, and the intended size of the resulting hole
Gluing	an area where glue will be applied
FoilStamping	an area where foil will be applied through hot foil stamping
ColdFoilStamping	an area where foil will be applied through cold foil stamping (using glue)
Embossing	an area where embossing will be applied
Debossing	an area where debossing will be applied
Perforating	where the substrate will be perforated
Bleed	the intended bleed for print
VarnishFree	an area where it is not allowed to have varnish
InkFree	an area where it is not allowed to have printing ink
InkVarnishFree	an area where it is not allowed to have printing ink or varnish
Folding	where the substrate will be folded without prior creasing
Punching	where the substrate will be punched, and the size and shape of the resulting holes
Stapling	where the substrate will be stapled or stitched, and the size of the staples or stitches to be used

**Positions Processing Steps**

Positions processing steps are contours giving the position of certain graphic elements (for example where a barcode should be, or which area of a folding carton flap can be printed). They can also be used to indicate areas where graphic elements shouldn't be printed.

This processing step type:	indicates:
Hologram	the intended position of holograms
Barcode	the intended position of barcodes
ContentArea	areas where it is allowed to place text and other graphical elements
CodingMarking	areas where additional information (not contained in the PDF) will be printed on the packaging at a post-press stage (such as on filling lines where the final products are being packed).

This processing step type:	indicates:
	These processing step objects are specific to packaging and can be used for lot numbers, production dates, best before dates, tracking codes...
Imprinting	areas where additional information will be printed in a secondary print stage (after most of the graphical content is already printed).  This can be used to indicate the position of variable data for example.

## Working with Processing Steps

### The Processing Steps tab

Imaging Engine and Pack Proof display the processing steps associated with the layers in your input file (or files placed in it) in the **Processing Steps** tab.

The list of processing steps that you see depends on various factors like the number of jobs you select, the input file type, etc.

If you select input files that are not PDF files	the <b>Processing Steps</b> tab will not be visible as processing steps are only applicable to PDF files  For example, for Normalized PDF files, the <b>Processing Steps</b> tab will always be hidden.
If you select only one job	only the processing steps of your job's printable layers are listed in the <b>Processing Steps</b> tab
If you select multiple jobs or if you don't select any job	all the processing steps supported by Imaging Engine and Pack Proof are listed
If your input file contains no layers	the processing steps tab will display an empty table with the "No printable processing steps found" message
If your input file contains layers that do not have equivalent processing steps in Imaging Engine/ Pack Proof	those layers will not be listed under this tab



**Note:** Adobe Illustrator layers can also be used as processing steps though they are not the same as PDF layers.

### Handling Processing Steps Content

By default, all processing steps are selected. This means that the processing steps data will be treated as regular content and go through the RIP. If an ink is only used by a processing step and that processing step is selected, Imaging Engine will output a separation for that ink.

If you don't want to output some processing step data (for example a cut line), deselect that processing step. You can also select or deselect a group: for example, deselect **Structural** to deselect all processing steps from that group.

Inks only used by deselected or non-printable processing steps will not be displayed in the **Inks** tab.

### Custom Processing Steps

You can add custom processing steps manually in the **Processing Steps** tab: use the **Add** button at the bottom of the tab (or the **Remove** button to remove a custom processing step).

This is useful if you want to use the same ticket with different selected/deselected processing steps for different files.



**Note:** You cannot add the same custom processing step twice.

## Inks

### Selecting Which Separations to Proof

Use the **Inks** settings to select which separations of the input file(s) you want to proof.

For example, you can use these settings to exclude technical and/or varnish inks from your output.

You can choose to proof either:

- **All** separations.
- A number of separations you select **Manually**.
- A number of separations you select **by using selection criteria**.

Selection criteria are rules that you define to select separations automatically for you when the task is launched on a file.

Selecting separations manually is the easiest option, but you can only do it on a file by file basis (when you launch the task on a single input file).

Using selection criteria is more advanced but also more powerful than selecting separations manually, and you can do it anytime (when launching the task on one or more input files, when using the task in a workflow, when defining ticket settings...).

Therefore, we recommend that you first try selecting separations manually when running the task on individual files, then switch to using selection criteria to automate your workflow further.



**Tip:**

To get used to working with selection criteria, try the following on a few of your files:

1. select the separations you want to output manually,
2. then change **Select Inks** to **by using selection criteria** and see which rules have been created based on your manual selection.

For more information, see [Selecting Inks Manually](#) on page 1310 and [Selecting Inks Using Selection Criteria](#) on page 1311.



**Tip:** You can also make the ink selection parameter public so that an operator can set it [through Shuttle](#) as needed for each job. See [Selecting Inks through Shuttle](#) on page 1315 for more information.

### Handling Unregistered Inks

Unregistered inks are inks that are not present in your *color management database*. Since there is no information about these inks apart from their RGB values in the input file, they cannot be color managed or proofed accurately.

Therefore, we recommend you exclude them from the output, especially for contract proofing.

Choose what to do in case some unregistered inks are still in the list of inks to be proofed:

- If you want the task to end with a warning, leave **Task ends in error when the job contains unregistered inks** deselected.  
All the inks you chose to include in the output will be proofed, but the unregistered inks will not be color accurate.
- If you want the task to end in error, select **Task ends in error when the job contains unregistered inks**.

In both cases, you will also see a message in the log.



**Note:** If your input file contains *PantoneLIVE inks* and you don't have a PantoneLIVE license, those inks will be treated as unregistered inks.



### Selecting Inks Manually



**Note:** You can only select inks manually when you are launching the task on a (single) file, not when you are defining a generic ticket without an input file.

When choosing to **Select Inks Manually**, you will see a table containing all of your document's inks, showing each ink's:

<b>Ink Name</b>	
<b>Ink Book</b>	If an ink book is not present in your color database, it will show here as <code>&lt;unregistered ""&gt;</code> .
<b>Ink Index</b>	<p>The <b>ink index</b> is the order in which the file's inks will be printed (the ink with ink index 1 is at the bottom of the document and will be printed first).</p> <p>If your file has several of the same ink, they will have the same ink index, and the next ink will have the next one (for example two Cyans will both have ink index 1, then Magenta will have ink index 2).</p> <p>This means that when selecting inks for processing, both Cyans will be selected together and handled the same way.</p>

	 <p><b>Tip:</b></p> <p>To find the ink index of a file:</p> <ol style="list-style-type: none"> <li>1. select the file in the Automation Engine Pilot's <b>Files</b> view,</li> <li>2. click ,</li> <li>3. in the <b>Info</b> dialog that opens, select <b>Inks</b> in the left panel.</li> </ol> <p>The order of the inks at right is the ink index (the topmost ink has an index of 1, the second of 2, etc.).</p> <p>Note that if you reorder the inks by one of the columns (for example by <b>Ink name</b>), they won't be ordered by ink index anymore. You will need to close that dialog and reopen it to see the ink index order again.</p>
<b>Spot Ink Index</b>	<p>The <b>Spot Ink index</b> is the order in which a spot ink will be printed (when counting only spot inks and not process inks).</p> <p>For example, if the first 4 inks of the document are CMYK, the first spot ink will have 5 as <b>Ink Index</b> but 1 as <b>Spot Ink Index</b>.</p> <p>As for the ink index, if your file has several of the same spot ink, they will have the same spot ink index, and will be handled together when you select them.</p>
<b>Ink Type</b>	<p>This can be for example <i>Normal, Technical, Varnish...</i></p>
<b>Printing Method</b>	<p>If you have set a <b>Printing Method</b> for an ink it will be shown here (this can be for example <i>Offset, Gravure, Flexo...</i> or any custom printing method you configured).</p> <p>See the Automation Engine documentation for more information about printing methods.</p>

Select the ink(s) you want to proof, or select the toggle in the table header to select/deselect all inks.

### Selecting Inks Using Selection Criteria

If you don't want to [select inks manually](#) every time, you can define some rules to automatically select certain inks in your input file(s).

You can do this:

- either when running the task on one or more files, or when creating a task ticket to use later,
- by choosing to **Select Inks by using selection criteria** in the **Document Inks** settings.

#### How Does it Work?

You select the inks to be output by checking a combination of criteria:

1. You define what to check. You can check any of the following ink characteristics in your criteria:

<b>Ink name</b>	
<b>Ink book</b>	
<b>Ink index</b>	<p>The <b>Ink index</b> is the order in which the file's inks will be printed (the ink with ink index 1 is at the bottom of the document and will be printed first).</p>

	<p>To find the ink index of a file:</p> <ol style="list-style-type: none"> <li>1. select the file in the Automation Engine Pilot's <b>Files</b> view,</li> <li>2. click ,</li> <li>3. in the <b>Info</b> dialog that opens, select <b>Inks</b> in the left panel.</li> </ol> <p>The order of the inks at right is the ink index (the topmost ink has an index of 1, the second of 2, etc.).</p> <p>Note that if you reorder the inks by one of the columns (for example by <b>Ink name</b>), they won't be ordered by ink index anymore. You will need to close that dialog and reopen it to see the ink index order again.</p>
<b>Spot ink index</b>	<p>The <b>Spot ink index</b> is the order in which a spot ink will be printed (when counting only spot inks and not process inks).</p> <p>For example, if the first 4 inks of the document are CMYK, the first spot ink will have 5 as <b>Ink index</b> but 1 as <b>Spot ink index</b>.</p>
<b>Ink type</b>	<p>This can be for example Normal, Technical, Varnish...</p>
<b>Printing method</b>	<p>If you have set a <b>Printing method</b> for an ink it will be shown here (this can be for example <i>Offset, Gravure, Flexo...</i> or any custom printing method you configured).</p> <p>See the Automation Engine documentation for more information about printing methods.</p>

For example, you can check whether the **Ink book is** process, whether the **Ink name is** yellow...

You can use as many criteria as you want.

2. You define how to combine your criteria into a rule. For example:

- If you want to output only process yellow, you should check for inks that match **both** of the criteria:

**Ink book is** process  
**Ink name is** yellow

- If you want to output both all process inks and all yellow inks, you should check for inks that match **either** of the criteria:

**Ink book is** process  
**Ink name is** yellow

- If you don't want to output any process inks or any yellow inks, you should check for inks that match **neither** of the criteria:

**Ink book is** process  
**Ink name is** yellow

**How Do I Build Rules?**

Build your rules the following way:

1. Choose how to combine the criteria in your rule:

- Select **All of the following are true** if you want to only select the inks that match **all** of the criteria you define.

- Select **Any of the following are true** if you want to select all the inks that match **at least one** of the criteria you define.
  - Select **None of the following are true** if you want to only select the inks that match **none** of the criteria you define.
2. Define your first selection criterion.

You can select an ink based on its:

- **Ink name:** you can define if it **contains/begins with/ends with/is** a piece of text (alphanumerical characters), or if it **is empty**.
- **Ink book:** you can define if it **contains/begins with/ends with/is** a piece of text (alphanumerical characters), or if it **is empty**.
- **Ink index:** you can define if it **equals/is less than/is greater than** the number you enter, or **is between** the two numbers you enter (in this case the ink indexes you enter as boundaries are also selected).
- **Spot ink index:** you can define if it **equals/is less than/is greater than** the number you enter, or **is between** the two numbers you enter (in this case the spot ink indexes you enter as boundaries are also selected).
- **Ink type:** you can define if it **is** a piece of text (alphanumerical characters).
- **Printing method:** you can define if it **is** a piece of text (alphanumerical characters).

For example, you could use:	to:
<b>All of the following are true</b> <b>Ink book is</b> <code>designer</code>	select all inks from the "designer" ink book
<b>None of the following are true</b> <b>Ink name is</b> <code>crease</code>	exclude an ink called "crease"
<b>None of the following are true</b> <b>Ink type is</b> <code>Technical</code> <b>Ink type is</b> <code>Varnish</code>	exclude all technical and all varnish inks



**Tip:**

- You can enter several values to check for: just use a semicolon (;) between them.  
For example, to check for both inks called `Cyan` and inks called `Magenta`, choose **Ink name is** and enter `Cyan;Magenta`.
- When launching the task on a file, you can also click  to select one or more of the **Ink names/Ink books/Ink types/Printing methods** used in your input file(s).  
A criterion will automatically be created based on your selection.

3. Click + to add more criteria and define them.

To remove a criterion, click - next to it.



**Tip:** If you are launching the task on a single input file, you will see a table listing the **Selected document inks**, and another table with the **Document inks that are not selected** under the rules you defined.



**Attention:** If no ink is selected, you cannot launch the task.

### Switching How You Select Inks

You can switch between the two methods of selecting inks (*manually* and *using selection criteria*), and this will keep the same inks selected.

#### Switching from Selecting Inks Manually to Selecting Inks Using Selection Criteria

When switching from selecting inks manually to selecting inks using selection criteria, the task will translate your manual ink selection into rules, so that the same inks are selected (you can see them in the **Selected document inks** table).

The rules you get are based on the characteristics of the inks you selected.

For example, if you selected all the process colors but no spot color in your file, for an offset job, you will get the following rule:

**All of the following are true**

**Ink name is** Cyan;Magenta;Yellow;Black

**Ink book is** process

**Ink type is** Normal

**Printing method is** Offset



**Note:**

If you...

- first selected inks using selection criteria,
- then switched to manual selection without changing the selection,
- then switched back to selection criteria,

... then your rules will be kept.

If you did change the selection in manual mode, the task will automatically generate new rules.

#### Switching from Selecting Inks Using Selection Criteria to Selecting Inks Manually

When switching from selecting inks using selection criteria to selecting inks manually, all the inks selected by the rules you defined (the inks in the **Selected document inks** table) become selected manually.



**Note:** You can only switch to selecting inks manually when you are launching the task on a (single) file.









### Selecting Inks through Shuttle

If you want to be able to decide which inks to proof when submitting your input file *through Shuttle*, do the following:

#### In Your Imaging Engine Ticket

- To make the ink selection a public parameter, you can either:
  - Right-click **Select Inks** and choose **Make Parameter Public**.
  - If you (are currently launching the ticket on a file and) have chosen to *select inks manually*, right-click the preview table under **Select Inks** and choose **Make Parameter Public**.

Select Inks: Manually

<input type="checkbox"/>	Ink Name	Ink Book	Ink Index	Spot Ink Ind...	Ink Type	Printing Met...
<input type="checkbox"/>	 Cyan	process	1	-	Normal	Unknown
<input type="checkbox"/>	 Magenta	process	2	-	Normal	Unknown
<input type="checkbox"/>	 Yellow	process	3	-	Normal	Unknown
<input type="checkbox"/>	 Black	process	4	-	Normal	Unknown
<input type="checkbox"/>	 crease	Visualizer St...	5	1	Technical	Unknown
<input type="checkbox"/>	 Cut	<unregistre...	6	2	Technical	Unknown

- If you have chosen to *use selection criteria*, right-click the rules builder under **Select Inks** and choose **Make Parameter Public**.

Select Inks: by using selection criteria

▼ Select inks that match the following criteria:

Any of the following are true

Ink name contains



**Note:** You will not be able to create rules using Shuttle, you will only be able to select inks manually.

- Go to **Advanced > Manage Public Parameters...**, find the **Ink Selection** parameter at the bottom of the list, and drag it to the right hand side.

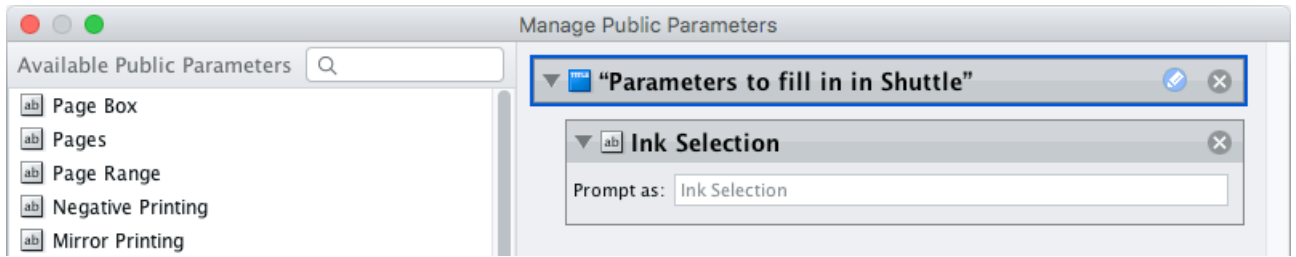

2. By default, the public parameter that appears in Shuttle will be called **Ink Selection**. You can change its name by:
  - right-clicking one of the elements mentioned above, selecting **Modify Public Parameter** and entering a new name,
  - if you are using the **Manage Public Parameters** window, entering the new name in **Prompt as**.
3. Make sure your ticket is also **Public**.

### In Shuttle

The ink selection parameter may look a bit different depending on which Shuttle you are using (the Shuttle standalone application or a Shuttle plug-in in an Editor application).

- In the Shuttle standalone, the ink selection parameter will look like this:

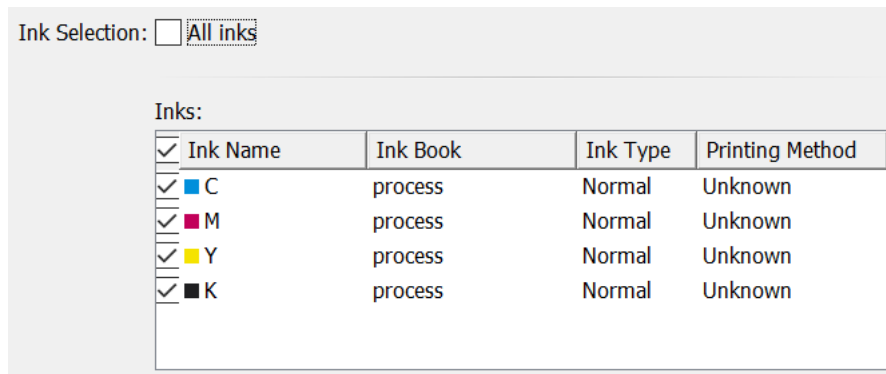

The table shows a preview of all inks in your input file, with their characteristics.

- To proof all inks from your input file, either leave all inks selected in the preview table, or select **All inks** at the top (this will hide the preview table).
- To only proof certain inks, make sure **All inks** is not selected, and deselect the input inks that you don't want to proof.
- In ArtPro+ for example, the ink selection parameter will look like this:

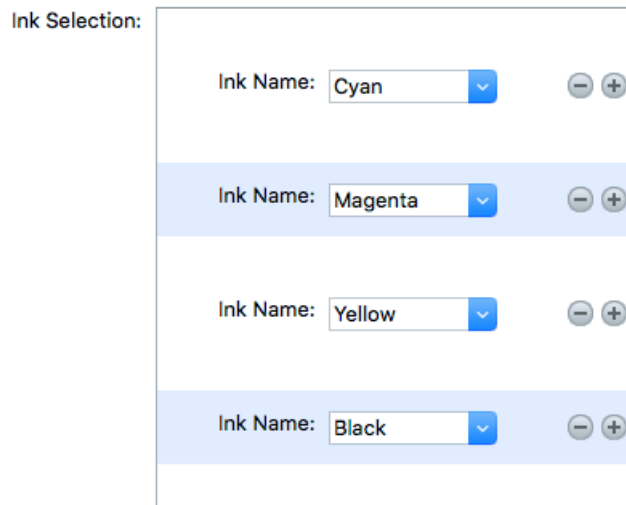

By default, all the inks from your input file will be proofed, but you can remove any ink you don't want to proof using the  button.

## Color Management

This is where you apply [color management](#) to your output file(s). To do this, you use a [color strategy](#) containing your color management settings.

You can apply two types of color management, depending on the type of proof you want to make:

### Standard Proof

If you are making a standard proof, you are creating a proofing file that you will later send to a proofer, to try and reproduce your press' output. In this case, we recommend that you:

1. Get the profile of the proofer you want to use, and use it as **destination profile** in your color strategy.
2. Use your press profile as **source profile** in your color strategy.

See [Color Management for Standard Proof](#) on page 1318.

### Emulation Proof

If you are working with both a regular press and a digital press, and you want to be able to move jobs between presses, you need to make sure they have comparable output.

This can be useful if you want to use your digital press instead of your main press to reprint a few copies of a job, or to print short run jobs (with the same results as on the regular press) in general.

In this case, you should make an **emulation proof**, that takes both presses into account when proofing. It will:

- first simulate how your regular press prints on your digital press,
- then simulate that simulation on your proofer.

This will help you find out which colors can or cannot be reproduced on your digital press, as a digital press can have a narrower gamut than both a regular press and a proofer.

See [Color Management for Emulation Proof](#) on page 1319.

### Color Management for Standard Proof

If you are making a standard proof, you are creating a proofing file that you will later send to a proofer, to try and reproduce your press' output. In this case, we recommend that you:

1. Get the profile of the proofer you want to use, and use it as **destination profile** in your color strategy.
2. Use your press profile as **source profile** in your color strategy.

See [Color Strategies](#) on page 1183 for more information about color strategies.

You can either select an existing color strategy (that you have created in Color Pilot), or create a new (basic) color strategy on-demand.

Note that when creating a basic color strategy on-demand, you will only be able to use it for the current task (you will not be able to store it, edit it later or reuse it).

- If you have created a color strategy in Color Pilot, select it in the **Color Strategy** list.

To be available in this list, your color strategy must be stored in the color database defined for your Automation Engine server (if your Esko software is set up correctly, Color Pilot saved it in the right place automatically).

You can also select your desired color strategy through a public parameter, or using a SmartName. The SmartName for the color strategy must resolve to one of the available color strategies.



**Note:** When you output to [JPEG](#) or to [composite TIFF](#) with JPEG [compression](#), you can only select color strategies that have a CMYK destination profile.

The default color strategy is **linear**.

- If you want to create a basic color strategy on demand:
  - a) Select **Create Custom Strategy...** in the **Color Strategy** list.
  - b) Select a **Source Profile** and a **Destination Profile**.



**Note:**

If your input file is a Normalized PDF that contains a document profile, and you want to use that as the source, select **Use document profile if available** (or use a SmartName resolving to `true`).

If the input file does not contain a document profile, the **Source Profile** you selected will be used instead.

PDF+ files don't contain document profiles (they use output intents instead).



**Note:** When you output to [JPEG](#) or to [composite TIFF](#) with JPEG [compression](#), you can only select a CMYK destination profile.

- c) Select a **Rendering Intent**.

See [Rendering Intents](#) on page 1184 for details on how each rendering intent handles the conversion of [out-of-gamut](#) spot colors and of the background color, and which to use in which case.



**Note:**

- If you are working with Esko source and destination profiles, you can use the **Absolute Colorimetric** or **Relative Colorimetric** rendering intent.
- If you are working with ICC source and destination profiles, you can use any rendering intent.

d) Click **OK**.

- If the **output intent** from the input file is different from the input profile of your proofing color strategy, it might result in wrong proofer output.

Choose what to do in that case:

- If you want the task to end in error, select **Task ends in error when the output intent is different from the source profile**. You can also use a SmartName resolving to `true`.
- If you want to output the file anyway, leave **Task ends in error when the output intent is different from the source profile** deselected (your task will end with a warning). You can also use a SmartName resolving to `false`. This is the default option.

In both cases, you will also see a message in the log.



**Note:** This option is only applicable to native PDF files and does not affect Normalized PDF files.

Once you have selected or created your desired color strategy, the task shows the **Source** and **Destination** profiles used in the strategy.

**Color Management for Emulation Proof**

If you are working with both a regular press and a digital press, and you want to be able to move jobs between presses, you need to make sure they have comparable output.

This can be useful if you want to use your digital press instead of your main press to reprint a few copies of a job, or to print short run jobs (with the same results as on the regular press) in general.

In this case, you should make an **emulation proof**, that takes both presses into account when proofing. It will:

- first simulate how your regular press prints on your digital press,
- then simulate that simulation on your proofer.

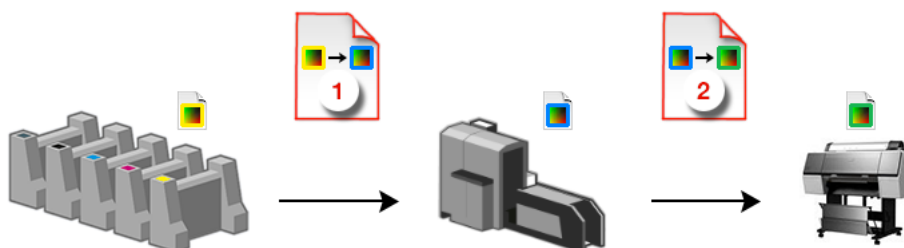

This will help you find out which colors can or cannot be reproduced on your digital press, as a digital press can have a narrower gamut than both a regular press and a proofer.



1. Select **Emulation Proof** to display color management settings for an emulation proof.
- 2.

Under **Analog Press**, select your first color strategy .

This color strategy should have:

- your regular press profile  as **Source Profile** (or the profile for a printing standard you want to match, for example `ISOcoated_V2_eci.icc`),
- your digital press profile  as **destination profile (Emulation Profile)**.

To be available in this list, your color strategy must be stored in the color database defined for your Automation Engine server (if your Esko software is set up correctly, Color Pilot saved it in the right place automatically).

You can also select your desired color strategy through a public parameter, or using a SmartName. The SmartName for the color strategy must resolve to one of the available color strategies.



**Note:**



You will only be able to choose a color strategy with a destination profile  that is the same as the source profile of the second color strategy (see below).

To choose a color strategy with a different destination profile, you need to first select a second color strategy that has that profile as source profile.

- 3.

Under **Digital Press**, select your second color strategy .

This color strategy should have:

- your digital press profile  as **Source Profile**,
- the profile of the proofer you want to use (or a profile with the right ink set if you don't know which proofer you will use yet)  as **Destination Profile**.



**Note:** When *outputting to JPEG or TIFF*, you can only select color strategies that have a CMYK destination profile.

To be available in this list, your color strategy must be stored in the color database defined for your Automation Engine server (if your Esko software is set up correctly, Color Pilot saved it in the right place automatically).

You can also select your desired color strategy through a public parameter, or using a SmartName. The SmartName for the color strategy must resolve to one of the available color strategies.

4. If the **output intent** from the input file is different from the input profile of your proofing color strategy, it might result in the generation of wrong proofer output.

Choose what to do when the output intent profile from file is different from the input profile of the proofing color strategy:

- If you want the task to end in error, select **Task ends in error when the output intent is different from the source profile**. You can also use a SmartName resolving to `true`.
- If you want to output the file anyway, leave **Task ends in error when the output intent is different from the source profile** deselected (your task will end with a warning). You can also use a SmartName resolving to `false`. This is the default option.

In both cases, you will also see a message in the log.



**Note:** This option is only applicable to native PDF files and does not affect normalized PDF files.

## File Output

Use the **File Output** settings to define what type of output you want and where to output it.

You can set these through public parameters or using SmartNames.

1. Enter your output **File Name** and output **Folder**.



### Note:

- You can use Imaging Engine-specific SmartNames for the **File Name**.  
By default, it is set to:
  - `[File]` for single page input files (which gives output file names like `Myfile.tif`),
  - `[File]_p[Page]` for multi-page input files (which gives output file names like `Myfile_p1.tif`).This is a good default for composite output.  
For separated output, we recommend you use:
  - `[File]_[ShortInk]` for single page input files (which gives output file names like `Myfile_C.tif`),
  - `[File]_p[Page]_[ShortInk]` for multi-page input files (which gives output file names like `Myfile_p1_C.tif`).
- The **File Name** and **Folder** can contain special characters (except `\ / : * ? < > " |`).
- The whole path to the output file (including the container, **Folder** and **File Name**) can be up to 255 characters.
- You can set a local or remote URL for the output **Folder**, but it must be an absolute path.
- If your output folder doesn't exist yet, the task will create it if the location you request is valid (you should place this folder on an Automation Engine container accessible by your Automation Engine user).

If the output folder creation fails, please check the task log for the full list of conditions and adapt your output folder path accordingly.

2. Define what to do if a file of the same name already exists in your output folder:

a) Click **Set Overwrite Policy...**

b) Choose what to do **If files exist already**. You can either:

- **Extend the file name** if you want to keep the existing output file and give the new output file a different name. In this case, your new output file name consists of:
  - the **Output file name** (the **File Name** you set earlier) - which is what the file would be called if no file with the same name existed,
  - a custom suffix that you can define using plain text and/or SmartNames (by default, this is `_c`, for "copy"),
  - an automatic suffix made of the three last digits of the task **ID**,



**Tip:**

To see the task ID of your tasks:

1. Go to the Pilot's **Tasks** pane (in the **Files** or **Tasks** view).
2. Go to **View > Select Columns in 'Tasks'...**
3. In the **Columns** dialog, select **Task ID** in the **Available columns** list and click  to move it to the **Show these columns:** list.
4. Click **OK**.
5. You now have a **Task ID** column in the **Tasks** pane, listing the task ID of all the tasks.

- the file extension.

For example, your input file is called `file.pdf` and you have left the tasks' output **File Name** to its default value (the SmartName **[File]**).

The first TIFF you generate will be called `file.tif`.

If you generate output from this input file again, with the task 3668, and you have set the overwrite policy to **Extend the file name** with the default **Output File Name + \_c + ID** name, the new output file will be called `file_c668.tif`



**Tip:**

- If you are working with the Bitmap Viewer, we recommend you keep the default overwrite policy (**Output File Name + \_c + ID**), which is compatible with the Bitmap Viewer.
- If you are not, you can define the custom suffix as you wish. For example, you could use date and time SmartNames.

- **Overwrite** the existing file(s).
- **End the task in error**.





**Note:** If you use a SmartName to set this, it must resolve to `extend` or 0 (for **Extend the file name**), `overwrite` or 1 (for **Overwrite**), or `error` or 2 (for **End the task in error**).

c) Click **Set**.

3. Select the output **File Type** you want. This can be a **TIFF File**, a **PDF File** or a **JPEG File**.

See [File Formats](#) on page 1224 for more information.

4. Select how you want to output your files in **File Assembly**.

- For **TIFF** files, you can choose to output either [composite](#) or [separated](#) files.
  - To output **Composite** files, select **1 File Per Page** in **File Assembly** (or use a SmartName that resolves to `FilePerPage`).

The **Output Type** is then automatically set to **Composite**.

- To output **Separated** files, select **1 File Per Separation** in **File Assembly** (or use a SmartName that resolves to `FilePerSeparation`).

The **Output Type** is then automatically set to **Separate**.

- For **PDF** and **JPEG** files, the task always generates **Composite** files.

The **File Assembly** is automatically set to **1 File Per Page**, and the **Output Type** set to **Composite**.



**Note:**

- Every output file that Imaging Engine generates contains XMP metadata (information about file creation, separations, calibration curves, etc.).

You can view this XMP metadata by selecting your output file in the Automation Engine Pilot's **Files** view and clicking [i](#).

For more information about XMP metadata, see the **XMP Metadata white paper** under **Related Documentation** on the [documentation page of your Imaging Engine version](#).

- TIFF files produced by Imaging Engine are fully compatible with Esko's Bitmap Viewer and DotSpy.
- Separated files are shown in the correct separation in the Bitmap Viewer (as it can read the separation information in the XMP data) and in grayscale in other viewers.
 

When proofing them, they are also in the correct separation (for example the proofer proofs the Magenta file using the Magenta cartridge).



**Tip:**

With separated output, you can easily see how *color management* affects your output separations relative to the input separations.

- If you are using a **linear Color Strategy** (that doesn't color manage process colors), the process separated output files will contain the same objects as the corresponding separations in the input file.

In the CMYK example below, each solid object in an input separation is the same in the output separation (for example the Cyan bar is still only 100% Cyan).



- If you selected something other than **linear** in the *Color Strategy* (you are color managing all separations of your file), the process output separations will be different from the corresponding input separations.

In the CMYK example below, each solid object in an input separation is now made up of several output separations (for example the Cyan bar is now 60% Cyan, 36% Magenta and 22% Black, and appears in these three separated output files).





**5. Choose the **Compression** to use for your output file(s).**

- For **TIFF** output, you can choose between lossless and lossy compression. Lossless compression preserves all the detail in the file, while lossy compression removes some detail.

We recommend you use lossless compression for the final output, and lossy compression only for previews and thumbnails.

For both compression types (lossless and lossy), you should then choose a compression method, based on the compression speed and the compressed file size. Typically, faster compression methods compress the file less, so the output file is bigger (note that TIFF files can be a maximum of 4GB).

<p>If you want lossless compression...</p>	<p>choose either:</p> <ul style="list-style-type: none"> <li>• <b>PackBits</b>, a fast lossless compression method for graphic files.</li> </ul> <div data-bbox="699 367 1426 456" style="border: 1px solid #ccc; padding: 5px; margin: 5px 0;">  <b>Tip:</b> Use this if you want fast output and file size is not too much of an issue.         </div> <ul style="list-style-type: none"> <li>• <b>LZW</b>, a lossless compression method for graphic files and other files.</li> </ul> <div data-bbox="699 573 1426 663" style="border: 1px solid #ccc; padding: 5px; margin: 5px 0;">  <b>Tip:</b> This compression method works best for files with large images.         </div>
<p>If you want lossy compression...</p>	<p>choose one of the <b>JPEG</b> compression methods (those are more suitable for images like photographs and natural artwork than sharp edged or flat color images like line art or lettering, as JPEG compression tends to introduce noise into solid color areas).</p> <p>They are sorted from very high compression, which reduces the file size a lot but loses a lot of detail (<b>JPEG Limited Quality</b>), to very low compression, which doesn't lose much detail but doesn't reduce the file size much (<b>JPEG Extreme Quality</b>).</p>

- For **PDF** output, all available compression methods are lossless.

You should choose a compression method based on the compression speed and the compressed file size. Typically, faster compression methods compress the file less, so the output file is bigger (note that PDF files can be a maximum of 12GB).

Choose either:

- **PackBits** (see above).
- **Flate**, a lossless compression method similar to zipping, based on the LZW compression.



**Tip:** This compression method works best for images with large single color areas or repeating patterns.

- **JPEG 2000**, a compression method based on **JPEG** and suitable for large images (the version of **JPEG 2000** used by Imaging Engine is lossless).
- For **JPEG** output, all available compression methods are lossy.

You should choose a compression method based on the compression speed and the compressed file size. Typically, faster compression methods compress the file less, so the output file is bigger.

They are sorted from very high compression, which reduces the file size a lot but loses a lot of detail (**JPEG Limited Quality**), to very low compression, which doesn't lose much detail but doesn't reduce the file size much (**JPEG Extreme Quality**).



**Attention:**

- When using a SmartName to set the output file's **Compression**, it must resolve to one of the following (case insensitive):
  - **PackBits, LZW, JPEGLimited, JPEGLow, JPEGStandardLow, JPEGStandard, JPEGStandardHigh, JPEGHigh, or JPEGExtreme** for **TIFF** output,
  - **PackBits, Flate** or **JPEG2000** for **PDF** output,
  - **JPEGLimited, JPEGLow, JPEGStandardLow, JPEGStandard, JPEGStandardHigh, JPEGHigh, or JPEGExtreme** for **JPEG** output.

Setting any other value, or an unsupported compression for the file type you chose, will make the task error (with the message **Unsupported combination of output type and compression** in the log).

- If you have already set the **Compression** but decide to change the output **File Type**, by default the task will either:
  - keep the same **Compression** (if it is supported for the new output **File Type**),
  - or (if it isn't), set it to the first **Compression** available for this **File Type**.

You can still change it as desired.

**6. Select **Make all output files ready for viewing** if:**

- you are generating separated (TIFF) files,
- you are doing quality control using the **Automation Engine Viewer**,
- you want to be able to open your output files in the **Automation Engine Viewer** without needing to use a **Prepare for Viewer** task.

If you don't use this option, you can still use a **Prepare for Viewer** task later to be able to view your output files in the **Automation Engine Viewer**. However, this will take more time than already preparing the files for viewing in your Imaging Engine task.

As with the **Prepare for Viewer** task, you will see **View (Prepared)** next to the prepared files in the Pilot, and you will be able to zoom in to the files up to their full resolution.



**Note:** If you use this option together with composite output files (via SmartNames or Public Parameters), the task will error out.

**Rendering**

Use the **Rendering** settings to define how to handle images that have a different resolution than the output resolution, and set [other rendering options](#) to optimize your output.

- 1. Set the **Resolution** of your output files.**



**Note:**

- The **Resolution** unit is taken from the general Automation Engine Preferences.
- You can enter values from 1 to 25400 ppi (or equivalent in your unit). SmartNames must also resolve to a value in that range.
- Values in another unit than the one from the general Preferences will be recalculated, and values like 300ppi + 500ppm will be calculated correctly.

2. If your input file contains outlines, line art or contourized text, and you notice that they look too thick on print, we recommend you select the **Fine Line Rendering** option.

This will render objects with fine lines, for example Asian characters or barcodes, with a "thin fill".

You can set this option with a SmartName resolving to `true` to use **Fine Line Rendering** or `false` to use the standard rendering (also known as "fat fill").



**Note:**

If you have an older saved ticket (created in a version of Imaging Engine older than 22.11) with the outdated **Compensate for Outline Thickness** option selected, **Fine Line Rendering** will be used instead.

You will see a message about this:

- when opening the ticket,
- in the task details,
- in the log file.

When using this ticket, the task will end with a warning.

You can choose to not show this message again (in this case it won't be mentioned in the ticket, task details or log file, and the task won't end with a warning), but please note that this will apply to all users of that ticket.

3. If you experience problems with jagged edges, for example in small text, you can set an **Anti-aliasing** factor to smooth those edges.

See [Anti-Aliasing](#) on page 1188 for more information.

You can adjust the amount of anti-aliasing applied by choosing a factor of either 2, 3 or 4 (note that using a higher anti-aliasing factor may slow down processing).

You can also set this with a SmartName resolving to `None` (if you don't need anti-aliasing), or to the anti-aliasing factor you want (for example 2).



**Attention:** Because anti-aliasing changes the output sampling to smooth the jagged edges, you cannot resample your images (with the **Image Resampling** option) if you use anti-aliasing.

4. If needed, you can [resample](#) your images.

This is typically needed when the images' pixels don't map exactly to output pixels, for example if:

- the images' resolution is different from your chosen [output resolution](#),

- scaling and rotation effects change the size and placement of the images' pixels.

In the **Image Resampling** option, choose the resampling method you want to use:

- Choose **Auto Resampling** to upsample the images to an automatically calculated resolution (generally half or a third of the output resolution) before smoothing them.

When using this, images are a lot less pixellated and fuzzy.

This method takes some time but gives images of a good quality, so it is recommended in most cases.

You can also use a SmartName resolving to `ResampleAuto`.

- Choose **Full Resampling** to upsample the images to the full output resolution.

This method is the slowest, but gives the highest quality images (not pixellated and only slightly fuzzy).

You can also use a SmartName resolving to `ResampleFull`.

Use this if **Auto Resampling** doesn't give you the results you want.



**Attention:**

Resampling to full resolution can require significant amounts of memory when the output resolution is high (especially from 4000 dpi).

If you want to do this, we recommend that you have at least 8GB of RAM available for each worker (see the installation documentation).

- Choose **None** if you don't want to resample your input file's images.



**Note:**

If you upgraded from a previous version of Imaging Engine, in some cases you may have saved a ticket with a less optimal resampling method (**From File** or **PDF Interpolation**) in your older version. These methods are deprecated from Imaging Engine 18.1.1.

When processing a file with such a ticket, Imaging Engine will use the **Auto Resampling** method instead. You will get a warning about this.

5. If your input file is a Step and Repeat file, choose whether you want **Identical One-Ups**.

This makes sure that on print, the details look the same in all your one-ups (see [Identical One-Ups](#) on page 1190 for more information).

- Select **On** if you want all one-ups of your input Step and Repeat files to look identical on print.



**Note:**

You can do this for the following input file types:

- *Plato* files (.pdfpla files or Normalized PDFs from Plato),
- Step and Repeat files in the Native PDF format (made by ArtPro+ or 3rd party software),
- Step and Repeat files in the ArtPro Classic file format (.ap or .art), if they were previously Normalized.



**Tip:**

If you were previously using FlexRip in combination with Plato, and setting the **Reset for each external file** option for **Screen Registration** in Plato, select **On** here to get a comparable result with Imaging Engine.

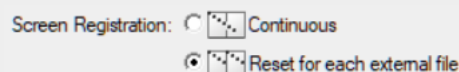

- Select **Off** if:
  - it is not important for you to have identical one-ups when doing Step and Repeat,
  - you are not currently working with Step and Repeat files or files with repeated placed art,
  - if you are re-running a separation from an old job, and want your screens to match the previous run,
  - you were satisfied with the screened output of previous versions of Imaging Engine that did not have this option (22.07 and older).

**Off** is selected by default. We recommend you leave it like this if you don't need identical one-ups, as rendering the one-ups identically can in some cases slow down your output.

- Select **Use from file** to use the information in your input Step and Repeat files to decide whether your one-ups need to be identical or not.

This is only applicable to Plato files with the **Screen Registration** parameter filled in.

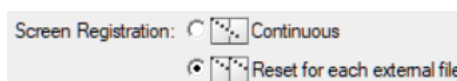

- If your input Plato file has the **Reset for each external file** option selected for the **Screen Registration** parameter, your one-ups will be aligned to the pixel grid to be made identical.
- If your input Plato file has the **Continuous** option selected for the **Screen Registration** parameter, your one-ups will be left as they are.

**Summary**

This shows a summary of all the settings you defined in the ticket.

- To show the settings from a tab, click + (on PC) or ► (on Mac) beside the tab name in the right pane. Click **Expand All** to show the settings from all tabs.
- To hide the settings from a tab, click - (on PC) or ▼ (on Mac) beside the tab name in the right pane. Click **Collapse All** to hide the settings from all tabs.

### 16.5.4. Image to Screened Separations

Use this task if you need *screened* output to send to a platesetter or filmsetter (for offset or flexo for example).

#### Task Output

The **Image to Screened Separations** task generates one file per separation, in either *PDF, TIFF, LEN or LENX format*.

For example, you can send screened LEN separations to the CDI.

In the example below, processing a file containing the lime green Esko star generates screened files for the Cyan, Yellow and Black separations.

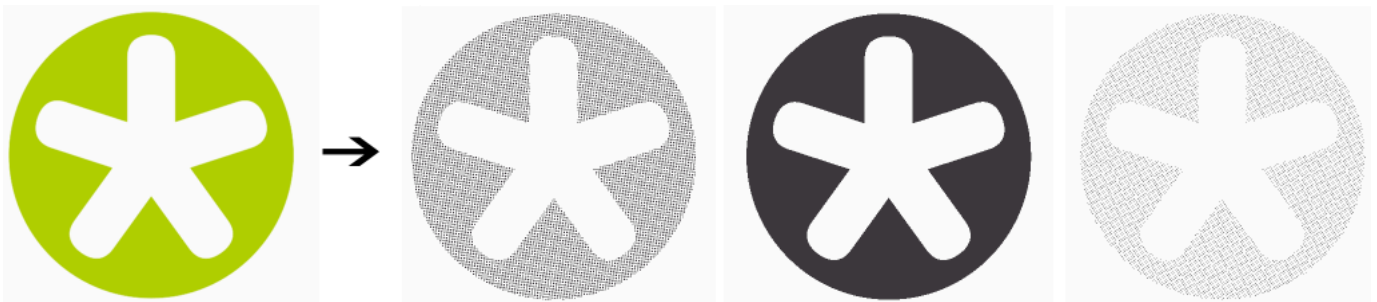

#### Task Parameters

1. In the **Device** field, select the imaging device *that you configured*.
2. If you have made a **Printing Condition** in the Print Control Wizard, you can use it in Imaging Engine. See *Working with Printing Conditions from the Print Control Wizard* on page 1331.  
If you don't have (a license for) the Print Control Wizard, the **Printing Condition** option is not visible.
3. Use the tabs at left to show more settings to fill in. See:
  - *General* on page 1333,
  - *Transformations* on page 1335,
  - *PDF Objects* on page 1336,
  - *Processing Steps* on page 1338
  - *Inks* on page 1343,
  - *File Output* on page 1350,



- [Separations](#) on page 1362,
- [Post-RIP](#) on page 1395,
- [Summary](#) on page 1398.

## Working with Printing Conditions from the Print Control Wizard

If you have made a printing condition in the Print Control Wizard, you can use it in Imaging Engine.

### What is the Print Control Wizard?

The Print Control Wizard is a set of tools in the Color Pilot application, designed to help you optimize your print quality.

Based on your exact production workflow, your current print quality and the standard you want to print towards, the Print Control Wizard calculates the best possible screens and curves that you can use to achieve great results on press.

This helps you avoid common problems, for example a lack of smoothness in the transition from highlights to paper, or from shadows to solids, and makes getting good printing quality time after time easier.

See [Print Control Wizard](#) for more information.

### What is a Printing Condition?

The Print Control Wizard generates a **printing condition** based on your production workflow settings and the measurement results of a print sample made with those settings.

This printing condition:

- describes your exact production workflow (plate-making workflow and printing setup) and the way it prints,
- includes the standard you want to print towards (an ISO standard, G7, linear printing...),
- results in the best possible **curve(s) and screen(s)** to achieve the quality of that standard with your production workflow.



If you do not have a license for the Print Control Wizard but you think it might be a good fit for your workflow, please contact your Esko representative.

### Using a Printing Condition

After [making your printing condition in the Print Control Wizard](#), you use it when RIP'ing your jobs with Imaging Engine to get great results on press.



**Important:**

- You can only use a printing condition if you have the license for it.
- You can only use a printing condition that you have **completed** (it has a /  **Ready for production Status** in the [Printing Condition Explorer](#).  
If you are still working on your printing condition in the Print Control Wizard, you will not be able to select it in Imaging Engine yet.
- After making a printing condition for your production workflow, you should always use it in Imaging Engine when printing with that production workflow.  
If you make changes to your workflow (for example you print on a different substrate, or you switch to a different ink vendor), we recommend you make a new printing condition in the Print Control Wizard.

**Selecting a Printing Condition**

There are different ways to select a **Printing Condition**:

- By selecting the **Printing Condition** from the drop-down list.
- By using a **SmartName** that resolves to an available printing condition. The task will fail if the SmartName does not resolve to a printing condition.
- By using a **public parameter**. The public parameter input follows the same rules as a SmartName.

The default selection is **None**.

When you select a printing condition, the following settings will be automatically filled in the **Image to Screened Separations** ticket.

- The output *file type* will be set to **LENX**.
- The output *resolution* will be set to **4000ppi** if your printing condition contains *Crystal screens* for **flexibles or labels**, and to **2540ppi** if your printing condition contains Crystal screens for **corrugated**.

You can find more information about the different types of printing conditions in the [Print Control Wizard User Guide](#).

- No *plate curve* will be selected and *press curves from the input file* cannot be used (as the printing condition already has a curve).
- Default **Screen** and **Curve** parameters are provided by the printing condition.
  - If the selected printing condition is an old printing condition (generated using the Print Control Wizard application) the press curve will be a `.prsync` file and you will be able to select a different press curve.
  - If the selected printing condition does not include default values for screens or curves, you will be able to select the dot, ruling, angle set and press curve manually (but the selected parameters will only be applied to the screens, without default values from the printing condition)
  - You can choose to use all the screen and curve values, or only angles or rulings (or both) from the file rather than from the printing condition.
  - You will still be able to set custom values for each separation manually by changing it in the preview table.
- In the ink preview table, you will see the screen based on values from the input file, the printing condition and custom settings.
- [Print simulations files](#) will be generated by default, but you can choose not to generate them.

- *Dot cleanup* will be selected, and the printing condition will set the minimum dot size (using the minimum dot size from the printing condition's screen). Pixels will be used as dot size unit.

If you choose a different printing condition, the settings will change according to the new printing condition.



**Note:** The custom values set by using the preview table will remain the same even if you change the printing condition.

The settings automatically filled by the printing condition cannot be changed except for **Dot cleanup** and **Print Simulation** settings. If you change the **Ruling** or **Minimum Dot Size** to a different value, a warning will be shown.

If you select a printing condition and then deselect it and change to `none`, all settings will remain except for the default screen and curve parameters, and dot cleanup settings.

### Using a SmartName

Using a **SmartName** will affect the same settings as a printing condition, but you will be able to overrule the defaults provided for the following settings:

- Default Ruling and Minimum Dot Size for Dot Cleanup.
- Default PressCurve, Angle Set, Dot and Ruling.

### General

1. Define what **Page Box** of the input PDF you want to RIP.

You can either select **Media Box**, **Trim Box**, or insert a SmartName `[]` that must resolve to either `media` or `trim`.

After selecting your file's page box you will see its dimensions under the **Page Box** option.

2. If your input file is a multi-page PDF, select which **Pages** you want to RIP:
  - a) First select **All pages**, **Odd pages only** or **Even pages only** in the **Pages** option.

You can also insert a SmartName resolving to either `All`, `Even` or `Odd`.

- b) Then you can refine your selection by entering page numbers or a **Page Range**.

You can separate page numbers by a comma, or use a dash to indicate a page range (for example `3, 6-9`). You can also use a SmartName resolving to page numbers and/or page ranges using this same format.





**Note:**

- Page numbers are always physical pages. If your document starts with page 5, you should not use 5 but 1 to get the first page.
- If you enter page numbers that are not part of your document, they will be excluded from the output (all the other valid pages will be RIP'ed).
- If you enter the same page(s) more than once (for example `1, 1-2`), it/they will only be output once.
- Pages are RIP'ed in the order of the document (entering `5-1` will be automatically changed to `1-5`).

3. If you want to invert your output so it is compatible with the output device or software system that will process it, click .

You can also click  or **Edit...** to insert a SmartName that must resolve to `1` or `true` (to invert the output), or to `0` or `false` (to leave the output as it is).

4. If you want to mirror your output so it is compatible with the output device or software system that will process it, click .

You can also click  or **Edit...** to insert a SmartName that must resolve to `1` or `true` (to mirror the output), or to `0` or `false` (to leave the output as it is).

5. If you want to add **SmartMarks (Classic)** or **Dynamic Marks** in your output file(s), select the **Type of Marks** you want to add and then select the specific **Mark Set** you want to use.

**SmartMarks (Classic)** or **Dynamic Marks** are marks whose content is variable, so you can make them display information about that specific job and use them as a production control. For example, you can include some of the parameters used during RIP'ing in your output file(s) by using SmartMarks (Classic) or Dynamic Marks.

You need to:

- a) First create the SmartMarks (Classic) you want to use in **PackEdge** or **Plato** and the Dynamic Marks in **ArtPro+** (see the PackEdge, Plato and Arpro+ manuals for more details).

You can create either:

- a general SmartMark (Classic) or Dynamic Mark (for example a corner mark or split mark),
- a Text Mark with Smart Text, that will display the information included in your input file,
- an Imaging Engine-specific Text Mark with Smart Text, that will display the parameters that you set in the ticket.



**Attention:**

Unless you exclusively use the [screening settings from your input file](#) in Imaging Engine:

1. When you create your SmartMark in PackEdge or Plato, make sure you use the RIP-related SmartMark attributes from the **Output Parameter** category, and not those from the **Ink/Color** category.
2. Add this SmartMark using your **Imaging Engine ticket** (don't add it to in your input file using PackEdge or Plato, or using the **Add SmartMarks** Automation Engine task).

This way, your SmartMark will display the RIP parameters set in your Imaging Engine ticket.

If your PackEdge, Plato or ArtPro+ application is linked to your Automation Engine server, your SmartMarks (Classic) or Dynamic Marks will automatically be saved in the correct location and will be available in Imaging Engine.

- b) Then select that SmartMark (Classic) or Dynamic Mark in your **Imaging Engine task** using the **Mark Set** option.

The SmartMarks (Classic) or Dynamic Marks will be added to each output file generated from your input file.

## Transformations

Use the **Transformations** settings to rotate or distort your output relative to your input file.

1. If you want to rotate your file's contents, select the **Rotation** you want to apply here.

This can be:

- **0°**
- **90° Counter Clockwise**
- **180°**
- **90° Clockwise**

Any other value will give an error.





**Note:**

- You can use a SmartName that resolves to 0, 90 (for **90° Counter Clockwise**), 180 or 270 (for **90° Clockwise**).
- You need to use a numerical value (`ninety` will not work).
- This is a public parameter, that you can fill in when submitting files through Shuttle.

2. If you want to apply **Distortion** to your file's contents, select the type of distortion to apply:

- a) **Flexo distortion**

If you want to apply **Flexo distortion**, enter the vertical  and horizontal  distortion percentages to use.

You can enter numerical values, or insert SmartNames that resolve to numerical values (without the % sign).



**Note:**

- The values should be within the 85%-115% range. If you enter a percentage outside of this range it will be automatically adjusted to the nearest value in the range (for example 80 will be adjusted to 85%).  
However, if you use a SmartName that resolves to a percentage outside the range, the task will end in error.
- You can enter a simple formula and it will be calculated automatically (for example you can enter `100+2` and this will be changed to 102%). This only works with numerical values and not with SmartNames.

You can find more information about Flexo distortion in [this knowledge base article](#).

- b) **Values from file**

If you selected **Values from file** and the input file contains distortion values, you will see these in the fields below (greyed out)



**Note:** The values should be within the 85%-115% range. If the input file's distortion values are outside of this range, the task will end in error.

c) **No distortion**

This is the default option and no distortion will be selected.

You can also use a SmartName that resolves to `Flexo`, `File` or `Not`.

## PDF Objects

Use the **PDF Objects** settings to define:

- how to color manage RGB objects in your input file,
- what dot gain compensation to apply to your input file's images.

All parameters in this tab are public parameters, that you can fill in when submitting files through Shuttle.

1. In **Default RGB Profile**, specify the profile to use if no profile is specified for a certain RGB object in the input file. The default is `srgb.icc`.

You can use a SmartName that resolves to the full profile name.

2. Select what output profile you want to use when converting RGB objects to CMYK:

- If you want to use the output profile from the input file (if there is one available), leave **Use output intent from file** selected (it is selected by default).
- If you don't want to use the output profile from the input file, deselect **Use output intent from file** and specify the output profile to use in **Output Color Profile**.

This output profile will also be used if there is none available in the input file.

The default is `ISOcoated_v2_300_eci.icc`.

For the **Use output intent from file** option, you can use a SmartName that resolves to `true` (to use the file's profile) or `false` (to not use it).

For **Output Color Profile**, you can use a SmartName that resolves to the full profile name.

3. Select **Use PDF transfer curves** if you want to use:

- the [Dot Gain Compensation curves](#) attached to the images in your input PDF. These curves compensate for the unwanted characteristics of the device that created the images (scanner, digital camera...).
- the **Color Correction curves** added by ArtPro+ version 20 and higher. These curves allow you to correct individual separations for color deviations on proof from the reference proof. The correction will be applied on both the proof and the production files.



**Note:**

You can only use the correction curves if the Color Correction curves option is enabled in the global Imaging Engine configuration.

Please contact Esko Support for assistance.

Aside from these curves applied on individual images or separations, you can still apply:

- a *plate curve* (to compensate for the dot growth or reduction –for example in Digital Flexo– happening when making the plate)
- and/or a *press curve* (to compensate for the dot gain on press)

... to the full file(s) before output.

You can use a SmartName that resolves to `true` (to use the input file's curves) or `false` (to not use them).

4. If you experience issues with a font that doesn't look smooth enough at your selected resolution, your font may have **font hinting errors**.

Font hinting is the rendering of the outline (vectorized) font to pixels. For certain fonts, this rendering sometimes doesn't give a visually pleasing result, especially at low resolutions. In the image below, the top font has font hinting errors, the bottom font doesn't.

Label Pack

Label Pack

Choose how to handle files containing font hinting errors:

- Leave **Task ends in error when the job contains font hinting errors** selected if you want the task to end in error when encountering font hinting errors. You can also use a SmartName resolving to `true`.
- Deselect **Task ends in error when the job contains font hinting errors** if you want to output your file anyway, whether it has font hinting errors or not (your task will end with a warning). You can also use a SmartName resolving to `false`.

This may lead to reduced quality rendering of the text, but it will not generate incorrect characters in your output file.

5. If your PDF+ input file has linked artwork and the external reference files have been modified, the changes do not get updated automatically in the PDF+ file. This will result in outdated data in the input as well as output files.

Choose how to handle files containing **outdated linked artwork**:

- Select **Task ends in error when linked artwork is not up to date** if you want the task to end in error if the input file contains outdated external references. You can also use a SmartName resolving to `true`.
- Deselect **Task ends in error when linked artwork is not up to date** if you want to output the file anyway, whether the references are outdated or not (your task will end with a warning). You can also use a SmartName resolving to `false`. This is the default option.

## Processing Steps

### What is a Processing Step?

PDF input files typically contain different types of objects, used at different stages of the production process: not only printable objects (that make up the design), but also other objects containing **post-processing data** (for example a cut path or crease lines).

Your production workflow needs to handle these object types accordingly.

If your customers, suppliers, etc. all define their post-processing data in their own way (for example a die cut path could be in a separation called "die" or "cut"), it can lead to:

- needing to make the production workflow more complex to catch all possibilities,
- loss of time,
- mistakes (possibly wasting plates or having a wrong print).

Imaging Engine and Pack Proof support the [ISO 19593 standard](#), that defines "**processing steps**" corresponding to different types of post-processing data. With input files that use these processing steps, you can work in a more uniform way, increasing efficiency and decreasing mistakes.

### Processing Step Groups

The **ISO 19593 standard** groups the different processing steps as follows:

#### Structural Data

Contours indicating how the printed product will be processed to make a 3D end product.

These include for example cutting, creasing and folding lines, and correspond to operations performed by finishing devices like die cutters, folder-gluers, etc.

#### Braille

Contours of objects representing braille content. The braille characters are made after printing, typically by a die cutter or inkjet device.

#### Legend

PDF objects outside the boundaries of the actual printed product (for example solid patches of the inks used in the design). They can contain job related data used in review, approval, and manual production steps.

#### Dimensions

These are also outside the printed area, and indicate the physical size of certain items in the design (using arrows, numbers and units).

#### Positions

Contours giving the position of certain graphic elements (for example where a barcode should be, or which area of a folding carton flap can be printed). They can also be used to indicate areas where graphic elements shouldn't be printed.

#### White

PDF objects indicating where the white backing ink (the opaque white ink used for white underprint on transparent or metallic substrates) will be on the design.

#### Varnish



PDF objects indicating where the varnish will go after printing.

Imaging Engine and Pack Proof also include the following custom processing steps groups by default:

**Esko\_PlateCutting**

Contours indicating how a flexo plate needs to be cut.

**Esko\_PlateID**

PDF objects containing information to identify the plate.



**Note:**

See [Structural Data Processing Steps](#) on page 1339 and [Positions Processing Steps](#) on page 1340 for a more detailed list of the processing steps in these groups.

See [Plate ID Processing Step](#) on page 1340 for more information on how to use the **Esko\_PlateID** processing step.

**Structural Data Processing Steps**

Structural data processing steps are contours indicating how the printed product will be processed to make a 3D end product.

These include for example cutting, creasing and folding lines, and correspond to operations performed by finishing devices like die cutters, folder-glueers, etc.

This processing step type:	indicates:
Cutting	where the printed artwork will be cut from the printed sheet (for example with a guillotine cutter or die cutting device)
PartialCutting	where the substrate will be cut partially (not entirely through the material)
ReversePartialCutting	where the substrate will be cut partially (not entirely through the material) on the back side of the substrate
Creasing	where the substrate will be creased to guide subsequent folding
ReverseCreasing	where the substrate will be creased on the back side of the substrate
CuttingCreasing	where the substrate will undergo alternating cutting and creasing
ReverseCuttingCreasing	where the substrate will undergo alternating cutting and creasing on the back side of the substrate
PartialCuttingCreasing	where the substrate will undergo alternating partial cutting and creasing
ReversePartial-CuttingCreasing	where the substrate will undergo alternating partial cutting and creasing on the back side of the substrate
Drilling	locations where the substrate will be drilled, and the intended size of the resulting hole
Gluing	an area where glue will be applied
FoilStamping	an area where foil will be applied through hot foil stamping
ColdFoilStamping	an area where foil will be applied through cold foil stamping (using glue)

This processing step type:	indicates:
Embossing	an area where embossing will be applied
Debossing	an area where debossing will be applied
Perforating	where the substrate will be perforated
Bleed	the intended bleed for print
VarnishFree	an area where it is not allowed to have varnish
InkFree	an area where it is not allowed to have printing ink
InkVarnishFree	an area where it is not allowed to have printing ink or varnish
Folding	where the substrate will be folded without prior creasing
Punching	where the substrate will be punched, and the size and shape of the resulting holes
Stapling	where the substrate will be stapled or stitched, and the size of the staples or stitches to be used

**Positions Processing Steps**

Positions processing steps are contours giving the position of certain graphic elements (for example where a barcode should be, or which area of a folding carton flap can be printed). They can also be used to indicate areas where graphic elements shouldn't be printed.

This processing step type:	indicates:
Hologram	the intended position of holograms
Barcode	the intended position of barcodes
ContentArea	areas where it is allowed to place text and other graphical elements
CodingMarking	<p>areas where additional information (not contained in the PDF) will be printed on the packaging at a post-press stage (such as on filling lines where the final products are being packed).</p> <p>These processing step objects are specific to packaging and can be used for lot numbers, production dates, best before dates, tracking codes...</p>
Imprinting	<p>areas where additional information will be printed in a secondary print stage (after most of the graphical content is already printed).</p> <p>This can be used to indicate the position of variable data for example.</p>

**Plate ID Processing Step**

Use the **Esko\_PlateID** processing step as part of a workflow involving **Plate ID**. A Plate ID element is a non-printable element imaged on the plate, that identifies this individual plate. This helps you when archiving and reusing plates for cost-cutting and speed reasons.

You need to use several Esko applications to work with Plate ID. Here is an overview of the workflow and how to use the **Esko\_PlateID** processing step in the **Image to Screened Separations** task.

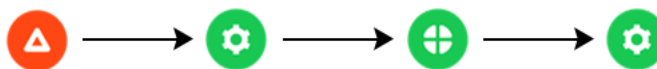

1. In **ArtPro+**, add a Plate ID element to your PDF+ input file, and decide on which separation(s) you want to apply it.

You can either:

- convert some text to a static Plate ID object,
- create a Plate ID (dynamic) mark.

Please see [the ArtPro+ documentation](#) for more information.



**Note:** Your file must be a **PDF+** file, not a Normalized PDF file.

2. In your **Automation Engine** workflow, you can update the Plate ID information in your input file if needed.

Please see [the Automation Engine documentation](#) for more information.

3. In **Imaging Engine's Image to Screened Separations** task, make sure that you select [output parameters](#) compatible with Plate ID:

- The [output file type](#) must be **LENX**.
- The output [resolution](#) must be either **2540 ppi** or **2400 ppi**.

4. On the **Image to Screened Separations's Processing Steps** tab, you can either:

- Leave the **Esko\_PlateID** processing step selected if you want to generate an extra LENX file containing only the Plate ID information, for quality control purposes.

You can open this file in the Automation Engine Viewer or the Bitmap Viewer, to check where the Plate ID information will be on your plate.

It is also easier to have located it at this point if you plan to do [another quality check after applying the Plate ID pattern](#), especially if your file is big and complex.



**Note:** At this point, the LENX files of the other separations only contain the Plate ID information as metadata, it is not visible yet.

- Deselect the **Esko\_PlateID** processing step if you don't want this.

You can still use Plate ID with the **Esko\_PlateID** processing step deselected, you just won't be able to have the same manual quality control step after the RIP.

5. In your **Automation Engine** workflow, use the **Apply Plate ID to LENX File** task to convert the Plate ID information (stored as metadata in the other separations) into the actual Plate ID pattern.

It will be added to the separations [you defined in ArtPro+](#).



**Note:**

Make sure you select the right plate type, as it also determines the pattern that will be used to image the Plate ID element on the plate.

This is because the Plate ID pattern for a specific plate and resolution is selected in the **DFS Merger** connected to the CDI. Please see the [Digital Flexo Suite documentation](#) for more information.

Please see [the Automation Engine documentation](#) for more information.

6. If desired, you can have an extra quality control step, to check the Plate ID patterns in the LENX separations.
7. Send your LENX separations to the **Submit to Plate Merger** task as usual.

Please see [the Automation Engine documentation](#) for more information.

## Working with Processing Steps

### The Processing Steps tab

Imaging Engine and Pack Proof display the processing steps associated with the layers in your input file (or files placed in it) in the **Processing Steps** tab.

The list of processing steps that you see depends on various factors like the number of jobs you select, the input file type, etc.

If you select input files that are not PDF files	the <b>Processing Steps</b> tab will not be visible as processing steps are only applicable to PDF files For example, for Normalized PDF files, the <b>Processing Steps</b> tab will always be hidden.
If you select only one job	only the processing steps of your job's printable layers are listed in the <b>Processing Steps</b> tab
If you select multiple jobs or if you don't select any job	all the processing steps supported by Imaging Engine and Pack Proof are listed
If your input file contains no layers	the processing steps tab will display an empty table with the "No printable processing steps found" message
If your input file contains layers that do not have equivalent processing steps in Imaging Engine/ Pack Proof	those layers will not be listed under this tab



**Note:** Adobe Illustrator layers can also be used as processing steps though they are not the same as PDF layers.

### Handling Processing Steps Content

By default, all processing steps are selected. This means that the processing steps data will be treated as regular content and go through the RIP. If an ink is only used by a processing step and that processing step is selected, Imaging Engine will output a separation for that ink.

If you don't want to output some processing step data (for example a cut line), deselect that processing step. You can also select or deselect a group: for example, deselect **Structural** to deselect all processing steps from that group.

Inks only used by deselected or non-printable processing steps will not be displayed in the **Inks** or **Separations** tabs and no separation will be generated for these inks.

### Custom Processing Steps

You can add custom processing steps manually in the **Processing Steps** tab: use the **Add** button at the bottom of the tab (or the **Remove** button to remove a custom processing step).

This is useful if you want to use the same ticket with different selected/deselected processing steps for different files.



**Note:** You cannot add the same custom processing step twice.

### Inks

Use the **Inks** settings to select which separations of the input file(s) you want to RIP.

For example, you can use these settings to exclude technical and/or varnish inks from your output.

You can choose to RIP either:

- **All** separations.
- A number of separations you select **Manually**.
- A number of separations you select **by using selection criteria**.

Selection criteria are rules that you define to select separations automatically for you when the task is launched on a file.

Selecting separations manually is the easiest option, but you can only do it on a file by file basis (when you launch the task on a single input file).

Using selection criteria is more advanced but also more powerful than selecting separations manually, and you can do it anytime (when launching the task on one or more input files, when using the task in a workflow, when defining ticket settings...).

Therefore, we recommend that you first try selecting separations manually when running the task on individual files, then switch to using selection criteria to automate your workflow further.



**Tip:**

To get used to working with selection criteria, try the following on a few of your files:

1. select the separations you want to output manually,
2. then change **Select Inks** to **by using selection criteria** and see which rules have been created based on your manual selection.

For more information, see [Selecting Inks Manually](#) on page 1344 and [Selecting Inks Using Selection Criteria](#) on page 1345.





**Tip:** You can also make the ink selection parameter public so that an operator can set it *through Shuttle* as needed for each job. See *Selecting Inks through Shuttle* on page 1348 for more information.

### Selecting Inks Manually



**Note:** You can only select inks manually when you are launching the task on a (single) file, not when you are defining a generic ticket without an input file.

When choosing to **Select Inks Manually**, you will see a table containing all of your document's inks, showing each ink's:

<b>Ink Name</b>	
<b>Ink Book</b>	If an ink book is not present in your color database, it will show here as <unregistered "">.
<b>Ink Index</b>	<p>The <b>ink index</b> is the order in which the file's inks will be printed (the ink with ink index 1 is at the bottom of the document and will be printed first).</p> <p>If your file has several of the same ink, they will have the same ink index, and the next ink will have the next one (for example two Cyans will both have ink index 1, then Magenta will have ink index 2).</p> <p>This means that when selecting inks for processing, both Cyans will be selected together and handled the same way.</p> <div style="border: 1px solid #ccc; padding: 5px; margin-top: 10px;">  <p><b>Tip:</b></p> <p>To find the ink index of a file:</p> <ol style="list-style-type: none"> <li>1. select the file in the Automation Engine Pilot's <b>Files</b> view,</li> <li>2. click ,</li> <li>3. in the <b>Info</b> dialog that opens, select <b>Inks</b> in the left panel.</li> </ol> <p>The order of the inks at right is the ink index (the topmost ink has an index of 1, the second of 2, etc.).</p> <p>Note that if you reorder the inks by one of the columns (for example by <b>ink name</b>), they won't be ordered by ink index anymore. You will need to close that dialog and reopen it to see the ink index order again.</p> </div>
<b>Spot Ink Index</b>	<p>The <b>Spot Ink index</b> is the order in which a spot ink will be printed (when counting only spot inks and not process inks).</p> <p>For example, if the first 4 inks of the document are CMYK, the first spot ink will have 5 as <b>ink index</b> but 1 as <b>Spot Ink Index</b>.</p> <p>As for the ink index, if your file has several of the same spot ink, they will have the same spot ink index, and will be handled together when you select them.</p>
<b>Ink Type</b>	This can be for example Normal, Technical, Varnish...
<b>Printing Method</b>	If you have set a <b>Printing Method</b> for an ink it will be shown here (this can be for example Offset, Gravure, Flexo... or any custom printing method you configured).

	See the Automation Engine documentation for more information about printing methods.
--	--------------------------------------------------------------------------------------

Select the ink(s) you want to RIP, or select the toggle in the table header to select/deselect all inks.

### Selecting Inks Using Selection Criteria

If you don't want to *select inks manually* every time, you can define some rules to automatically select certain inks in your input file(s).

You can do this:

- either when running the task on one or more files, or when creating a task ticket to use later,
- by choosing to **Select Inks by using selection criteria** in the **Document Inks** settings.

#### How Does it Work?

You select the inks to be output by checking a combination of criteria:

1. You define what to check. You can check any of the following ink characteristics in your criteria:

<b>Ink name</b>	
<b>Ink book</b>	
<b>Ink index</b>	<p>The <b>Ink index</b> is the order in which the file's inks will be printed (the ink with ink index 1 is at the bottom of the document and will be printed first).</p> <p>To find the ink index of a file:</p> <ol style="list-style-type: none"> <li>1. select the file in the Automation Engine Pilot's <b>Files</b> view,</li> <li>2. click ,</li> <li>3. in the <b>Info</b> dialog that opens, select <b>Inks</b> in the left panel.</li> </ol> <p>The order of the inks at right is the ink index (the topmost ink has an index of 1, the second of 2, etc.).</p> <p>Note that if you reorder the inks by one of the columns (for example by <b>Ink name</b>), they won't be ordered by ink index anymore. You will need to close that dialog and reopen it to see the ink index order again.</p>
<b>Spot ink index</b>	<p>The <b>Spot ink index</b> is the order in which a spot ink will be printed (when counting only spot inks and not process inks).</p> <p>For example, if the first 4 inks of the document are CMYK, the first spot ink will have 5 as <b>Ink index</b> but 1 as <b>Spot ink index</b>.</p>
<b>Ink type</b>	This can be for example Normal, Technical, Varnish...
<b>Printing method</b>	<p>If you have set a <b>Printing method</b> for an ink it will be shown here (this can be for example <i>Offset, Gravure, Flexo...</i> or any custom printing method you configured).</p> <p>See the Automation Engine documentation for more information about printing methods.</p>

For example, you can check whether the **Ink book is** process, whether the **Ink name is** yellow...

You can use as many criteria as you want.

2. You define how to combine your criteria into a rule. For example:

- If you want to output only process yellow, you should check for inks that match **both** of the criteria:

**Ink book is** process  
**Ink name is** yellow

- If you want to output both all process inks and all yellow inks, you should check for inks that match **either** of the criteria:

**Ink book is** process  
**Ink name is** yellow

- If you don't want to output any process inks or any yellow inks, you should check for inks that match **neither** of the criteria:

**Ink book is** process  
**Ink name is** yellow

**How Do I Build Rules?**

Build your rules the following way:

1. Choose how to combine the criteria in your rule:

- Select **All of the following are true** if you want to only select the inks that match **all** of the criteria you define.
- Select **Any of the following are true** if you want to select all the inks that match **at least one** of the criteria you define.
- Select **None of the following are true** if you want to only select the inks that match **none** of the criteria you define.

2. Define your first selection criterion.

You can select an ink based on its:

- **Ink name:** you can define if it **contains/begins with/ends with/is** a piece of text (alphanumerical characters), or if it **is empty**.
- **Ink book:** you can define if it **contains/begins with/ends with/is** a piece of text (alphanumerical characters), or if it **is empty**.
- **Ink index:** you can define if it **equals/is less than/is greater than** the number you enter, or **is between** the two numbers you enter (in this case the ink indexes you enter as boundaries are also selected).
- **Spot ink index:** you can define if it **equals/is less than/is greater than** the number you enter, or **is between** the two numbers you enter (in this case the spot ink indexes you enter as boundaries are also selected).
- **Ink type:** you can define if it **is** a piece of text (alphanumerical characters).
- **Printing method:** you can define if it **is** a piece of text (alphanumerical characters).



For example, you could use:	to:
<p><b>All of the following are true</b></p> <p><b>Ink book is</b> <code>designer</code></p>	select all inks from the "designer" ink book
<p><b>None of the following are true</b></p> <p><b>Ink name is</b> <code>crease</code></p>	exclude an ink called "crease"
<p><b>None of the following are true</b></p> <p><b>Ink type is</b> <code>Technical</code></p> <p><b>Ink type is</b> <code>Varnish</code></p>	exclude all technical and all varnish inks



**Tip:**

- You can enter several values to check for: just use a semicolon (;) between them. For example, to check for both inks called `Cyan` and inks called `Magenta`, choose **Ink name is** and enter `Cyan;Magenta`.
- When launching the task on a file, you can also click  to select one or more of the **Ink names/Ink books/Ink types/Printing methods** used in your input file(s). A criterion will automatically be created based on your selection.

3. Click + to add more criteria and define them.

To remove a criterion, click - next to it.



**Tip:** If you are launching the task on a single input file, you will see a table listing the **Selected document inks**, and another table with the **Document inks that are not selected** under the rules you defined.



**Attention:** If no ink is selected, you cannot launch the task.

### Switching How You Select Inks

You can switch between the two methods of selecting inks (*manually* and *using selection criteria*), and this will keep the same inks selected.

#### Switching from Selecting Inks Manually to Selecting Inks Using Selection Criteria

When switching from selecting inks manually to selecting inks using selection criteria, the task will translate your manual ink selection into rules, so that the same inks are selected (you can see them in the **Selected document inks** table).

The rules you get are based on the characteristics of the inks you selected.

For example, if you selected all the process colors but no spot color in your file, for an offset job, you will get the following rule:

**All of the following are true**

**Ink name is** `Cyan;Magenta;Yellow;Black`

**Ink book is** process  
**Ink type is** Normal  
**Printing method is** Offset



**Note:**

If you...

- first selected inks using selection criteria,
- then switched to manual selection without changing the selection,
- then switched back to selection criteria,

... then your rules will be kept.

If you did change the selection in manual mode, the task will automatically generate new rules.

**Switching from Selecting Inks Using Selection Criteria to Selecting Inks Manually**

When switching from selecting inks using selection criteria to selecting inks manually, all the inks selected by the rules you defined (the inks in the **Selected document inks** table) become selected manually.



**Note:** You can only switch to selecting inks manually when you are launching the task on a (single) file.

**Selecting Inks through Shuttle**

If you want to be able to decide which inks to RIP when submitting your input file *through Shuttle*, do the following:

**In Your Imaging Engine Ticket**

1. To make the ink selection a public parameter, you can either:
  - Right-click **Select Inks** and choose **Make Parameter Public**.
  - If you (are currently launching the ticket on a file and) have chosen to *select inks manually*, right-click the preview table under **Select Inks** and choose **Make Parameter Public**.

Select Inks: Manually

<input type="checkbox"/>	Ink Name	Ink Book	Ink Index	Spot Ink Ind...	Ink Type	Printing Met...
<input type="checkbox"/>	Cyan	process	1	-	Normal	Unknown
<input type="checkbox"/>	Magenta	process	2	-	Normal	Unknown
<input type="checkbox"/>	Yellow	process	3	-	Normal	Unknown
<input type="checkbox"/>	Black	process	4	-	Normal	Unknown
<input type="checkbox"/>	crease	Visualizer St...	5	1	Technical	Unknown
<input type="checkbox"/>	Cut	<unregistere...	6	2	Technical	Unknown

- If you have chosen to *use selection criteria*, right-click the rules builder under **Select Inks** and choose **Make Parameter Public**.

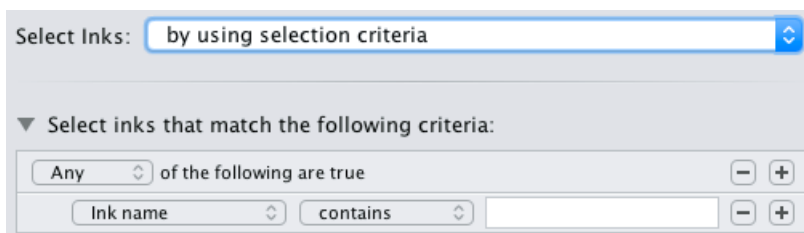

**Note:** You will not be able to create rules using Shuttle, you will only be able to select inks manually.

- Go to **Advanced > Manage Public Parameters...**, find the **Ink and Screening Selection** parameter at the bottom of the list, and drag it to the right hand side.

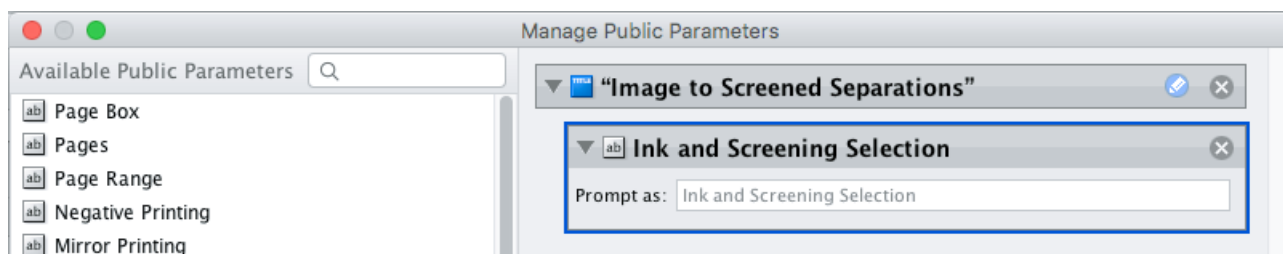

2. By default, the public parameter that appears in Shuttle will be called **Ink and Screening Selection**. You can change its name by:
  - right-clicking one of the elements mentioned above, selecting **Modify Public Parameter** and entering a new name,
  - if you are using the **Manage Public Parameters** window, entering the new name in **Prompt as**.
3. Make sure your ticket is also **Public**.

### In Shuttle

The ink selection parameter may look a bit different depending on which Shuttle you are using (the Shuttle standalone application or a Shuttle plug-in in an Editor application).

- In the Shuttle standalone, the ink selection parameter will look like this:

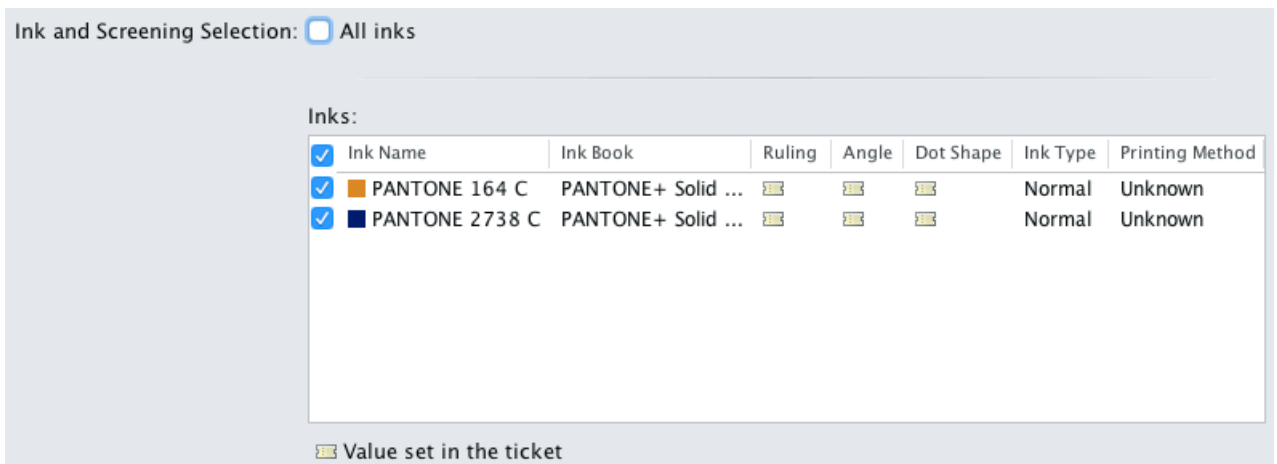

The table shows a preview of all inks in your input file, with their characteristics.

- To RIP all inks from your input file, either leave all inks selected in the preview table, or select **All inks** at the top (this will hide the preview table).
- To only RIP certain inks, make sure **All inks** is not selected, and deselect the input inks that you don't want to RIP.
- In ArtPro for example, the ink selection parameter will look like this:

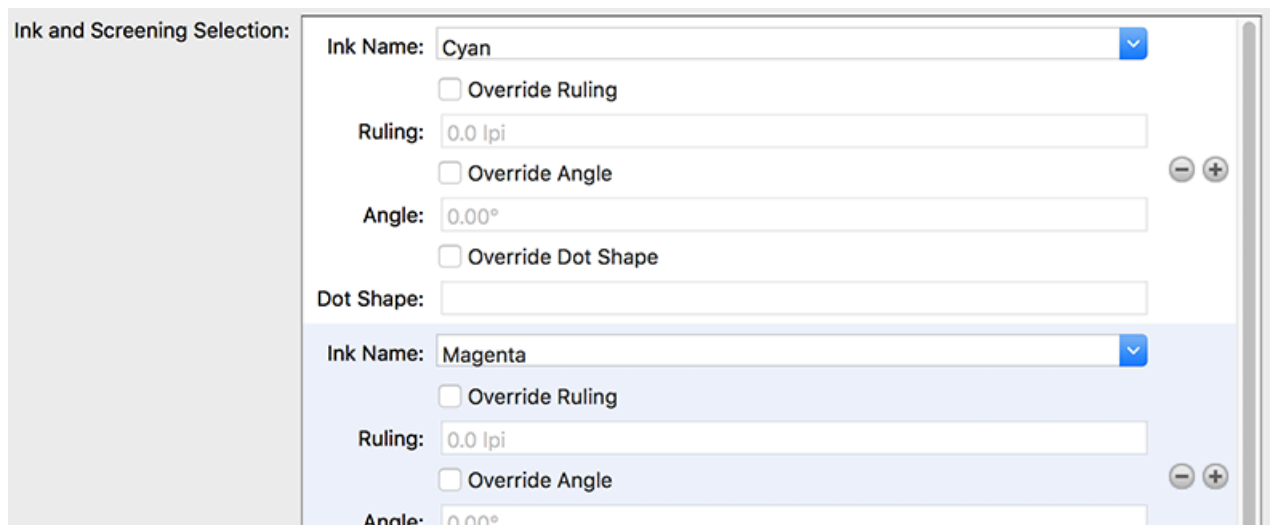

By default, all the inks from your input file will be RIP'ed, but you can remove any ink you don't want to RIP using the  button.



**Note:** This public parameter also enables you to choose the screening parameters to use for the inks you want to RIP. See [Selecting Screening Parameters through Shuttle](#) on page 1379 for more information.

### File Output

Use the **File Output** settings to define what type of output you want and where to output it.

You can set these through public parameters or using SmartNames.

1. Enter your output **File Name** and output **Folder**.



**Note:**

- You can use Imaging Engine-specific SmartNames for the **File Name**.  
For example, you can add the [Printing Unit] SmartName if you have added printing unit information in ArtPro+. This way, the printing unit number will be included in the file name, making it easier for the press operator to know on which printing tower of the press each separation should be printed.  
By default, the **File Name** is set to:
  - [File]\_[ShortInk] for single page input files (which gives output file names like Myfile\_C.tif),
  - [File]\_p[Page]\_[ShortInk] for multi-page input files (which gives output file names like Myfile\_p1\_C.tif).
- The **File Name** and **Folder** can contain special characters (except \ / : \* ? < > " |).
- The whole path to the output file (including the container, **Folder** and **File Name**) can be up to 255 characters.
- You can set a local or remote URL for the output **Folder**, but it must be an absolute path.
- If your output folder doesn't exist yet, the task will create it if the location you request is valid (you should place this folder on an Automation Engine container accessible by your Automation Engine user).  
If the output folder creation fails, please check the task log for the full list of conditions and adapt your output folder path accordingly.

2. Define what to do if a file of the same name already exists in your output folder:

a) Click **Set Overwrite Policy...**

b) Choose what to do **If files exist already**. You can either:

- **Extend the file name** if you want to keep the existing output file and give the new output file a different name. In this case, your new output file name consists of:
  - the **Output file name** (the **File Name** you set earlier) - which is what the file would be called if no file with the same name existed,
  - a custom suffix that you can define using plain text and/or SmartNames (by default, this is \_c, for "copy"),
  - an automatic suffix made of the three last digits of the task **ID**,



**Tip:**

To see the task ID of your tasks:

1. Go to the Pilot's **Tasks** pane (in the **Files** or **Tasks** view).
2. Go to **View > Select Columns in 'Tasks'...**
3. In the **Columns** dialog, select **Task ID** in the **Available columns** list and click  to move it to the **Show these columns:** list.
4. Click **OK**.
5. You now have a **Task ID** column in the **Tasks** pane, listing the task ID of all the tasks.

- the file extension.

For example, you are working with a CMYK input file called `file.pdf` and you have left the tasks' output **File Name** to its default value (the SmartName **[File]**).

The first TIFF files you generate will be called:

- `file_C.tif`
- `file_M.tif`
- `file_Y.tif`
- `file_K.tif`

If you generate output from this input file again, with the task 3669, and you have set the overwrite policy to **Extend the file name** with the default **Output File Name + \_c + ID** name, the new output files will be called:

- `file_C_c669.tif`
- `file_M_c669.tif`
- `file_Y_c669.tif`
- `file_K_c669.tif`



**Tip:**

- If you are working with the Bitmap Viewer, we recommend you keep the default overwrite policy (**Output File Name + \_c + ID**), which is compatible with the Bitmap Viewer.
- If you are not, you can define the custom suffix as you wish. For example, you could use date and time SmartNames.

- **Overwrite** the existing file(s).
- **End the task in error.**



**Note:** If you use a SmartName to set this, it must resolve to `extend` or 0 (for **Extend the file name**), `overwrite` or 1 (for **Overwrite**), or `error` or 2 (for **End the task in error**).

c) Click **Set**.

3. Select the output **File Type** you want to generate.



**Note:**

The file formats you can generate with your Imaging Engine software depend on your license. Please contact your Esko sales representative for more information.

See [File Formats](#) on page 1224 for more information about the different file formats.

You can choose to generate:

- a **TIFF File**,
- a **PDF File**,
- a **LENX File**,



**Note:**

- If you are using a [printing condition](#), the output files are always **LENX**.
- You need to output to **LENX** if you are using [Crystal screens](#) (either if you select a CRS screen in the ticket -in the [default screening settings](#) or with an [exception-](#), or if the screening settings in your input file contain one or more Crystal screens).
- In versions of Imaging Engine before 20.1, you could only generate **LENX** files together with Crystal screens and a [resolution](#) of 4000 ppi. In newer versions, you can also use the LENX format with other dots/screens and resolutions.
- To make plates from your **LENX** files, you need a CDI Crystal with version 18.1 or newer of the Grapholas/Digital Flexo Suite software.
- If your workflow involves [Plate ID](#), you should always generate **LENX** output, with a [resolution](#) of either 2540 ppi or 2400 ppi.

- a **LEN File**.



**Attention:**

If you use *Crystal screens* and you set the output file type to **LEN**, you will get a warning that you need to switch to **LENX** and the task will not launch (when launching the task manually), or it will switch to **LENX** automatically and end in a warning (in a workflow or when using a SmartName resolving to **LEN**).

However, you can use LEN:

- if your input file does not contain Crystal screens,
- if it does, but you make *exceptions* to use other screens than the Crystal screens from your input file,
- if it does, but you choose not to *use the dot shape from your input file*.



**Note:**

If you are opening or launching old tickets set to use **LEN/LENX** as **File Type**, the file type will automatically become:

- **LENX** if crystal screens are present,
- **LEN** if crystal screens are not selected.

4. The task generates *separated* output for all file types. This means you get one output file per page of the input file, and per output separation.

The **File Assembly** is automatically set to **1 File Per Separation**, and the **Output Type** set to **Separate** (for all file types).



**Note:**

- Every output file that Imaging Engine generates contains XMP metadata (information about file creation, separations, calibration curves, etc.).

You can view this XMP metadata by selecting your output file in the Automation Engine Pilot's **Files** view and clicking .

For more information about XMP metadata, see the **XMP Metadata white paper** under **Related Documentation** on the [documentation page of your Imaging Engine version](#).

- TIFF files produced by Imaging Engine are fully compatible with Esko's Bitmap Viewer and DotSpy.
- LEN files produced by Imaging Engine are fully compatible with Esko's CDI (Cyrel Digital Imager), just as LEN files produced by FlexRip.
- LENX files produced by Imaging Engine are compatible with version 18.1 of the Grapholas/Digital Flexo Suite software accompanying your CDI.

5. Choose the **Compression** to use for your output files.





**Note:**

For screened output, all available compression methods are lossless (so you don't lose any of the high-resolution detail).

You should choose a compression method based on the compression speed and the compressed file size. Typically, faster compression methods compress the file less, so the output file is bigger.

Note that TIFF files can be a maximum of 4GB, PDF files 12GB, and LEN files are unlimited. Files using stochastic screening are generally larger.

- For **TIFF** output, choose either:
  - **PackBits**, a fast lossless compression method for graphic files.



**Tip:** Use this if you want fast output and file size is not too much of an issue (if you have a fast network for example).

- **LZW**, a lossless compression method for graphic files and other files.



**Tip:** This compression method works best for files with large images.

- **CCITT Group 4**, a lossless compression method only used for files containing black and white.



**Tip:**

- This compression method works best for files with a lot of text.
- Use this if having a small output file is more important than processing speed (for example, if you want to store your screened files on a server to rerun jobs later, or if you are working with really large input files that may give screened TIFFs of over 4GB).

- For **PDF** output, choose either:
  - **PackBits** (see above).
  - **Flate**, a lossless compression method similar to zipping, based on the LZW compression.



**Tip:** This compression method works best for images with large single color areas or repeating patterns.

- **CCITT Group 4** (see above).

- For **LENX** output, choose:

- **Flate** (see above).



**Note:** If you have no compression (**None**) selected for LENX output, **Flate** compression will be automatically applied.

- For **LEN** output, choose either:

- **Flate** (see above).

- no compression (**None**).



**Tip:** The **Compression** method offered by default for the output **File Type** you select (**LZW** for **TIFF**, **PackBits** for **PDF** and **Flate** for **LEN** or **LENX**) is generally the best for this file type.



**Attention:**

- When using a SmartName to set the output file's **Compression**, it must resolve to one of the following (case insensitive):
  - **PackBits**, **LZW** or **CCITT-G4** for **TIFF** output,
  - **PackBits**, **Flate** or **CCITT-G4** for **PDF** output,
  - **Flate** for **LENX** output.
  - **Flate** or **None** for **LEN** output.

Setting any other value, or an unsupported compression for the file type you chose, will make the task error (with the message **Unsupported combination of output type and compression** in the log).

- If you have already set the **Compression** but decide to change the output **File Type**, by default the task will either:
  - keep the same **Compression** (if it is supported for the new output **File Type**),
  - or (if it isn't), set it to the first **Compression** available for this **File Type**.

You can still change it as desired.

6. If you are using a screen with *advanced screening effects*, select **Save print simulations** to also generate print simulation files (that you can use for easier quality control).

Print simulation files look like the screened files you are making for production, but with the advanced screening effects removed, so you can open them in the **Bitmap Viewer** and check exactly how your output will look like.

See [Performing Quality Control on Screens with Advanced Screening Effects](#) on page 1217 for more information.



**Note:** If you are using a *printing condition*, Imaging Engine will generate print simulation files by default (as the *Crystal screens* in your printing condition may contain advanced screening effects such as Pixel+ and/or support dots).

Imaging Engine creates one print simulation file for each screened separation, and saves the print simulation files in the same place as your screened separations. Print simulation files have a `.view` extension.

For example, if you are generating the following screened separations:

- `file_C.tif`
- `file_M.tif`

- file\_Y.tif
- file\_Y.tif

and you choose to also generate print simulation files, you will have the following files alongside your screened separations:

- file\_C.view
- file\_M.view
- file\_Y.view
- file\_Y.view

You can then open these .view files in the [Bitmap Viewer](#) for quality control.

**Tip:**

The first time you want to open a print simulation file in the Bitmap Viewer, do the following:

1. Right-click the print simulation file and select **Open With** then **Other...**
2. In the **Select Application** dialog that opens, click **Register...**
3. In the **Register** dialog that opens, click **Browse...** and browse to the executable of your Bitmap Viewer application.

If you installed it in the location proposed by default, the path should look like either:

- C:\Esko\BitmapViewer\_x64\BitmapViewer.exe if you have installed the 64-bit version of the application,
- C:\Program Files (x86)\BitmapViewer\BitmapViewer.exe if you have installed the 32-bit version of the application.

4. Click **OK**.
5. Click **Open** in the **Select Application** dialog.

The next time you want to use the Bitmap Viewer, you can just right-click your file, select **Open With**, and select **BitmapViewer**.

You can also compare the print simulation file and the corresponding screened separation in the Bitmap Viewer (see the Bitmap Viewer documentation for information about comparing files).

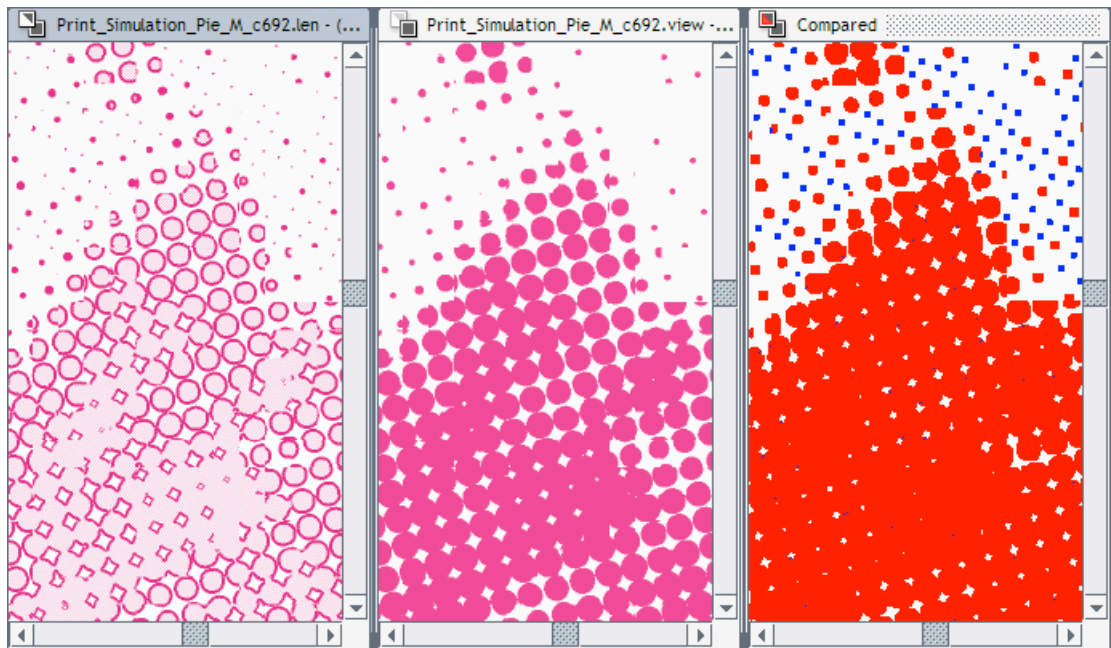

**Tip:**

You can also compare your print simulation files to your input file(s) in the Automation Engine Viewer.

To be able to open print simulation files in the Automation Engine Viewer, you need to either:

- use the **Make all output files ready for viewing** option in your Imaging Engine task,
- use Automation Engine's **Prepare for Viewer** task after your Imaging Engine task in your workflow.



**Note:** If you use the **Image to Screened Separations** task in a workflow and choose to generate print simulations files, they will go through an extra output pin called **Preview Files**.

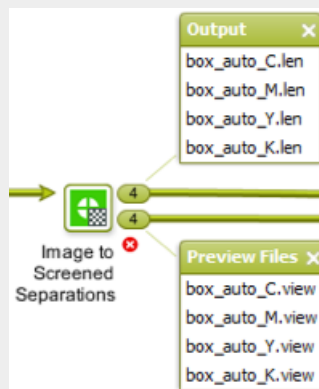

7. Select **Make all output files ready for viewing** if you are doing quality control using the **Automation Engine Viewer** and generating **TIFF, LEN** or **LENX** files.

Use this option to be able to open your output files in the **Automation Engine Viewer** without needing to use a **Prepare for Viewer** task.

If you don't use this option, you can still use a **Prepare for Viewer** task later to be able to view your output files in the **Automation Engine Viewer**. However, this will take more time than already preparing the files for viewing in your Imaging Engine task.

This prepares both your RIP'ed files and your *print simulation* files (if you are using them) for viewing with the **Automation Engine Viewer**.

As with the **Prepare for Viewer** task, you will see **View (Prepared)** next to the prepared files in the Pilot, and you will be able to zoom in to the files up to their full resolution.

**Note:**

- If you are generating **PDF** files, you can view them in the **Automation Engine Viewer** without preparation.  
However if you are generating print simulation files for those PDFs (see above), you still need to prepare your files for viewing (as the **Automation Engine Viewer** doesn't open print simulation files natively).
- You can also view **TIFF, LEN** and **LENX** files in the **Bitmap Viewer** without preparation.

## Rendering

Use the **Rendering** settings to define how to handle images that have a different resolution than the output resolution, and set [other rendering options](#) to optimize your output.

1. Set the **Resolution** of your output files.
  - The **Resolution** unit is taken from the general Automation Engine Preferences.
  - You can enter values from 1 to 25400 ppi (or equivalent in your unit). SmartNames must also resolve to a value in that range.
  - Values in another unit than the one from the general Preferences will be recalculated, and values like 300ppi + 500ppm will be calculated correctly.

Depending on the **Resolution** you set here, you will have different screen **Rulings** available in the [Separations tab](#).



**Note:**

- If you are using a [printing condition](#), the resolution is automatically set to **4000ppi** if your printing condition contains [Crystal screens](#) for **flexibles or labels**, and to **2540ppi** if your printing condition contains Crystal screens for **corrugated**.  
You can find more information about the different types of printing conditions in the [Print Control Wizard User Guide](#).
- If you have an input file with screening settings specifying [Crystal screens](#) or [HD Flexo screens](#), and you try to process it with a saved ticket in which the input file's dot shape *is used* (and not overridden by any [exception](#)), you will get an error.
- If your workflow involves [Plate ID](#), you should always generate [LENX output](#), with a resolution of either 2540 ppi or 2400 ppi.

2. If your input file contains outlines, line art or contoured text, and you notice that they look too thick on print, we recommend you select the **Fine Line Rendering** option.

This will render objects with fine lines, for example Asian characters or barcodes, with a "thin fill".

You can set this option with a SmartName resolving to `true` to use **Fine Line Rendering** or `false` to use the standard rendering (also known as "fat fill").



**Note:**

If you have an older saved ticket (created in a version of Imaging Engine older than 22.11) with the outdated **Compensate for Outline Thickness** option selected, **Fine Line Rendering** will be used instead.

You will see a message about this:

- when opening the ticket,
- in the task details,
- in the log file.

When using this ticket, the task will end with a warning.

You can choose to not show this message again (in this case it won't be mentioned in the ticket, task details or log file, and the task won't end with a warning), but please note that this will apply to all users of that ticket.

3. If needed, you can [resample](#) your images.

This is typically needed when:

- the images' resolution is different from your chosen [output resolution](#),
- scaling and rotation effects change the size and placement of the images' pixels.

In the **Image Resampling** option, choose the resampling method you want to use:

- Choose **Auto Resampling** to upsample the images to an automatically calculated resolution (generally half or a third of the output resolution) before smoothing them.

This method takes some time, but gives images of a good quality and significantly reduces the risk of broken dots, so it is recommended in most cases.

You can also use a SmartName resolving to `ResampleAuto`.

- Choose **Full Resampling** to upsample the images to the full output resolution.

This method is the slowest, but gives the highest quality images, with no risk of broken dots.

You can also use a SmartName resolving to `ResampleFull`.

Use this if **Auto Resampling** doesn't give you the results you want.



**Attention:**

Resampling to full resolution can require significant amounts of memory when the output resolution is high (especially from 4000 dpi).

If you want to do this, we recommend that you have at least 8GB of RAM available for each worker (see the installation documentation).

- Choose **None** if you don't want to resample your input file's images.



**Note:**

If you upgraded from a previous version of Imaging Engine, in some cases you may have saved a ticket with a less optimal resampling method (**From File** or **PDF Interpolation**) in your older version. These methods are deprecated from Imaging Engine 18.1.1.

When processing a file with such a ticket, Imaging Engine will use the **Auto Resampling** method instead. You will get a warning about this.

4. If your input file is a Step and Repeat file, choose whether you want **Identical One-Ups**.

This makes sure that on print, the details look the same in all your one-ups (see [Identical One-Ups](#) on page 1190 for more information).

- Select **On** if you want all one-ups of your input Step and Repeat files to look identical on print.



**Note:**

You can do this for the following input file types:

- *Plato* files (`.pdfpla` files or Normalized PDFs from Plato),
- Step and Repeat files in the Native PDF format (made by ArtPro+ or 3rd party software),
- Step and Repeat files in the ArtPro Classic file format (`.ap` or `.art`), if they were previously Normalized.



**Tip:**

If you were previously using FlexRip in combination with Plato, and setting the **Reset for each external file** option for **Screen Registration** in Plato, select **On** here to get a comparable result with Imaging Engine.

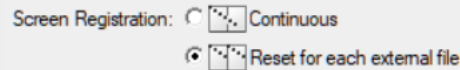

- Select **Off** if:
  - it is not important for you to have identical one-ups when doing Step and Repeat,
  - you are not currently working with Step and Repeat files or files with repeated placed art,
  - if you are re-running a separation from an old job, and want your screens to match the previous run,
  - you were satisfied with the screened output of previous versions of Imaging Engine that did not have this option (22.07 and older).

**Off** is selected by default. We recommend you leave it like this if you don't need identical one-ups, as rendering the one-ups identically can in some cases slow down your output.

- Select **Use from file** to use the information in your input Step and Repeat files to decide whether your one-ups need to be identical or not.

This is only applicable to Plato files with the **Screen Registration** parameter filled in.

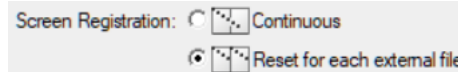

- If your input Plato file has the **Reset for each external file** option selected for the **Screen Registration** parameter, your one-ups will be aligned to the pixel grid, and their screening will start from the same point, so they are identical on print.
- If your input Plato file has the **Continuous** option selected for the **Screen Registration** parameter, your one-ups will be left as they are.

## Separations

Use the **Separations** settings to define the *screening* and *dot gain compensation* to apply to the separations that will be output (the separations you selected in the *Inks tab*).

You can:

- use the settings saved in the input file,
  - apply general settings to all output separations, by either specifying a **Dot, Ruling** and/or **Default Press Curve**, or by *selecting a printing condition*,
  - apply specific settings to certain separations.
1. Use **Seamless screening** if you are printing several copies of a job continuously on the substrate, and want to minimize *moiré* at the seam between jobs.



See [Seamless Screening](#) on page 1210 and [Using Seamless Screening](#) on page 1368 for more information.

2. If your input file contains screening settings, you can have the task use (some of) those if desired.

In **Use From File**, select which setting(s) to use:

- select **None** if you want to ignore any screening settings present in the input file and only use settings you define here,
- select **All** if you want to use all the screening settings (dot shape, ruling and angle) present in the input file (this is selected by default),
- select **Angle only** if you want to use the screen angles defined in the file, but use the dot shape and ruling defined here,
- select **Ruling only** if you want to use the ruling defined in the file, but use the dot shape defined here (the task then uses offset angles for your separations),
- select **Angle and ruling** if you want to use the angles and ruling defined in the file, but use the dot shape defined here.

You can use SmartNames resolving to `none`, `all`, `angle`, `ruling` or `angleandruling`.



**Note:**

If your input file...

- has specific screening settings for certain objects,
- was exported as Normalized PDF from either ArtPro (14.1 or later) or ArtPro+ (14.1.1 or later),

... then Imaging Engine will screen these objects with their specific settings when using the input file's settings.

For objects in the file that don't have any screening settings assigned, Imaging Engine will use the **Default Screening Settings** you define here.

For information about assigning screening settings to specific objects in ArtPro or ArtPro+, see the [ArtPro](#) or [ArtPro+](#) documentation.

3. Click **Advanced Screening Settings...** to set options to modify your chosen screen.

See [Using Advanced Screening Settings](#) on page 1370.

4. Define **Default Screening Settings** for the settings you are not taking from your input file (or as a back-up if some settings you wanted to take from the file are missing).

The settings you define here are applied to all separations (but you will still be able to define specific settings per separation later).



**Note:** If you are using a printing condition, the default dot and ruling for every separation are taken from the printing condition. In that case, **Dot** and **Ruling** will show **set by Printing Condition**, and will not be editable.

- a) In **Dot**, select the screen/dot shape to use.

You can choose from a list of screens installed on your Automation Engine server (on the screens server).

Screens have a short name and a long name. For example **R** -> **Round Fogra** (**R** being the short name and **Round Fogra** the long name).

- Screens with a short name beginning with **CRS** are *Crystal screens*, custom screens created in the **Print Control Wizard**.

Please see the [Print Control Wizard documentation](#) for more information.



**Note:**

- You can only use a CRS screen when outputting your job to *LENX files*.
- When you *use a printing condition*, Imaging Engine uses the Crystal screen(s) defined in that printing condition (and automatically sets the *output file type* and *output resolution* correctly).

You can also select a Crystal screen without using a printing condition, but you may get incorrect output (for example if you set the wrong output resolution).

- Screens with a short name beginning with **HD** are custom screens created in **HD Flexo**. Please see the HD Flexo documentation for more information.



**Note:** You can only use an HD Flexo screen when outputting your job to *LEN files*.

- Screens with a short name beginning with **SCR** are custom screens created in **ScreenManager**. Please see the ScreenManager documentation for more information.
- Screens with a short name beginning with another prefix are predefined screens:
  - *screens with standard dot shapes*,
  - *screens with advanced dot shapes*,
  - *stochastic (FM) screens*,
  - *legacy screens* you have from an old version of FlexRip or Nexus RIP (any legacy screen for which you have a license will have been copied to your Automation Engine server during installation).



**Tip:**

- When selecting a screen, they are listed alphabetically by short name.
- When using a SmartName to set the screen, it should resolve to either the screen's short name or its long name (not both).

- b) Select the **Angle Set** for the task. You can choose either **Offset** (the default), **Flexo -7.5**, and **Flexo +7.5**. You can also use a SmartName resolving to one of these values.



**Note:**

Some angle sets are not available for certain dots. When this is the case, you will see (not available for the selected dot) next to the angle set, and it will be grayed out.

For example, when using a C0 (Endless), CD0 (TwinBeam), or CD1 (CDI MultiBeam Optimized) dot, you cannot use the **Offset Angle Set**.

c) Select the **Ruling** to use.



**Note:**

Displayed values under the **Ruling** selection list depend on the **Dot** you selected, on the **Angle Set** for the task, and on the **Resolution** you entered in the [Output settings](#).

If you have used SmartNames for the **Dot** and/or **Resolution**, you will not see **Ruling** values to choose from, and you will need to enter a ruling manually (which must be a valid ruling for the dot shape and output resolution your SmartNames resolve to).

If you have specified the **Angle Set** through a SmartName, you will see all rulings available for all angle sets, each followed by the application type in parentheses, i.e. 43 lpi (Flexo only), 57 lpi (Offset only), etc.

When using a SmartName for the **Ruling**, make sure it resolves to the ruling value in lpi but without the unit (for example it should resolve to 150 for 150 lpi).

This ruling is applied to all separations, but you can [change the yellow ruling](#) to minimize yellow moiré.



**Note:**

You can make the screening parameters (dot shape, ruling, and angles) public so that they are editable in other applications, such as Automation Engine Shuttle and PackEdge.

To make these parameters public, right-click anywhere inside the exception rules table of the **Separations > Exceptions** tab, and select **Make Parameter Public** from the context menu.

If the task already contains a single input file, you can alternatively right click anywhere inside the inks preview table of the **Separations** tab, or even anywhere inside the inks preview table of the **Inks** tab.

Inks and screening parameters are grouped together for preview, and making either one public implies that the other one will be made public as well.

5. If desired, you can apply a **Plate Curve** to all output separations.

A plate curve is used to compensate for the dot growth or dot reduction (for example in Digital Flexo) happening when making the plate. You can choose either:

- **None** if you don't want to apply any plate curve.
- **Single Curve** if you want to apply one curve for all separations.

In this case, select the `.dgc` curve to apply at right. You can choose from a list of curves available in the curves database.

- **Curve Strategy** if you want to apply a curve strategy (a file created in Curve Pilot that contains several curves to apply in different cases: it can have different curves per separation, dot shape, ruling, for continuous tone images or line work...).

In this case, select the `.icpro` curve strategy or legacy `.scrdgc` screen-based DGC file to apply at right.

You can choose from a list of curve strategies available in the curves database.

For more information, see:

- [Dot Gain Compensation Curves](#) on page 1220,
- [DGC Curve Strategies](#) on page 1221,
- [The Curves Database](#) on page 1224.



**Note:** If you are using a [printing condition](#), no **Plate Curve** is used (as the printing condition contains dot gain compensation curves).



**Note:**

- You can use SmartNames resolving to the exact name of the **Single Curve** or **Curve Strategy** (including the extension).
- This will set the **Plate Curve** type to `Unknown` in the ticket, but will resolve to the correct curve type if the SmartNames are correct.

6. If your input file contains objects that have a press curve assigned, you can choose to use those curves if desired: select **Use press curves from file**.



**Tip:**

Select this if you have assigned dot gain compensation curves from Imaging Engine's curves database to your input file's objects using ArtPro 14.1 or later.

See the [ArtPro documentation](#) for more information.

For objects in the file that don't have a press curve assigned, Imaging Engine will use the **Default Press Curve** you define here.



**Note:** If you are using a [printing condition](#), it is not possible to use the press curves from the input file (as the printing condition contains dot gain compensation curves).

7. Define the **Default Press Curve** you want to use on the output separations (or on the objects that do not have a press curve assigned if you selected **Use press curves from file**).



**Note:** If you are selecting a printing condition, the **Default Press Curve** is set to the PressSync curve from the printing condition. It can still be changed afterwards.

This curve is used to compensate for the dot gain on press. You can choose either:

- **None** if you don't want to apply any press curve,
- **Single Curve** if you want to apply one curve for all separations (you can still define exceptions for some of the separations later).

In this case, select the `.dgc` curve to apply at right. You can choose from a list of curves available in the curves database.

- **Curve Strategy** if you want to apply a curve strategy (a file created in Curve Pilot that contains several curves to apply in different cases: it can have different curves per separation, dot shape, ruling, for continuous tone images or line work...).

In this case, select the curve strategy to apply at right (you can select a `.icpro` curve strategy, a `.prsync` PressSync curve set or a legacy `.scrdgc` screen-based DGC file).

You can choose from a list of curve strategies available in the curves database.

- **PressSync** if you want to apply a PressSync curve (a predefined curve applicable to your printing environment).

In this case, select the letter and number of the PressSync curve.

For more information, see:

- [Dot Gain Compensation Curves](#) on page 1220,
- [DGC Curve Strategies](#) on page 1221,
- [PressSync Curves](#) on page 1222,
- [PressSync Curve Sets](#) on page 1223,
- [The Curves Database](#) on page 1224.



**Note:**

- You can use SmartNames resolving to the exact name of the **Single Curve, Curve Strategy** (including the extension) or **PressSync** curve.
- This will set the **Default Press Curve** type to `Unknown` in the ticket, but will resolve to the correct curve type if the SmartNames are correct.

8. When launching the task on a single file, you can see the file's separations and the settings that will be applied to them in a preview table.

You can also use this table to define custom screening and dot gain compensation settings for specific separations: click in the **Dot, Ruling, Angle** or **Press Curve** column, and enter/select the value you want to use for that ink.

Your custom values are shown in italics.



**Note:** If you enter a **Ruling** or **Angle** value that is not valid for the separation's **Dot** shape, Imaging Engine will change it to the closest valid ruling or angle when RIP'ing.

If you want to go back to the previous setting, right-click the value you just set and select **Clear Custom Value**.



**Tip:** You can use this table to make your ink selection and screening parameters public, so that an operator can set them [through Shuttle](#) when submitting a job. See [Selecting Screening Parameters through Shuttle](#) on page 1379 for details.

9. If you notice a dot gain compensation problem in your job, and you want to compensate for it without changing your main curves, you can apply some corrections (to all separations).

See [Corrections](#) on page 1381.

10. If you are setting up a task ticket to use in a workflow for example, you can create a rule to always apply a specific setting to a specific separation.

You can do this if for example you have a curve you want to use for Yellow in all your jobs, or to use specific screens for specific spot colors...

See [Exceptions](#) on page 1392 to know how to create rules.



**Tip:**

Applying a specific setting to a specific separation manually (in the preview table) also automatically creates a rule. So if you are not used to working with rules yet, you can:

1. Take a file containing the separations you usually work with, and open the task on it.
2. In the **Separations** table, set your desired screening and/or dot gain compensation settings on your separations manually.
3. The task automatically creates the corresponding rules in the **Exceptions** tab (if you change your settings again, these rules will be updated).
4. Save your ticket. You can now use it on other files that need the same settings for those separations.

**Using Seamless Screening**

If you want to use [seamless screening](#), we recommend you do the following:

1. When preparing your input file, make sure that its horizontal dimension matches the sleeve size around the drum.

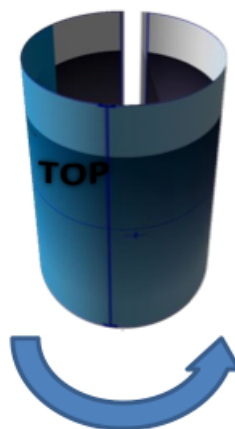

You can check this in PackEdge for example.

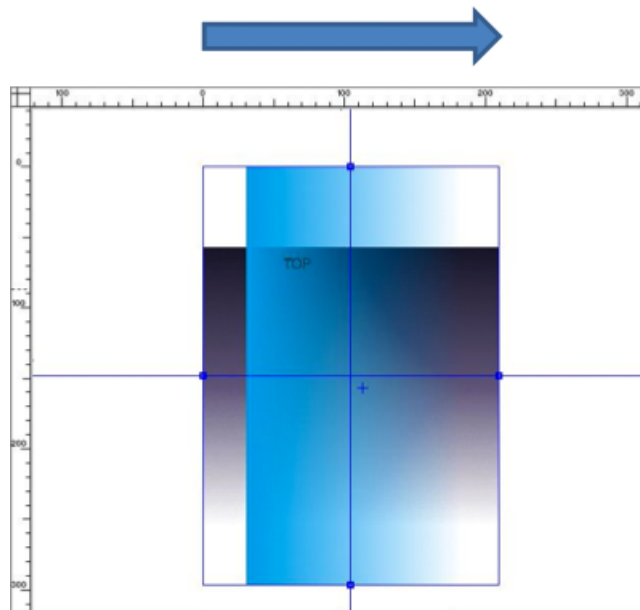

2. When RIP'ing your file with the **Image to Screened Separations** task, select the following [Separations](#) settings:
  - a) Select **Seamless screening**.
  - b) Select a **Dot** shape/screen that is compatible with seamless screening.



**Note:**

You can use seamless screening with any dot shape/screen except:

- stochastic screens,
- Groovy screens,
- Samba or SambaFlex screens,
- Paragon or other legacy Artwork Systems screens,
- HD Flexo screens with advanced screening effects (the dot, screen ruling and angle can be made be seamless, but not the advanced screening effects).

Dot shapes/screens that are not compatible with seamless screening are shown in grey with the mention (not available for seamless screening).



**Attention:** If you *chose to use* all the screening settings specified in your input file (including the dot), and that dot is not compatible with seamless screening, the task will end in error.

RIP'ing a file with seamless screening is slightly slower since the screens need to be generated dynamically.

However the processing time depends mostly on other factors (the number and type of screens that need to be processed for each separation, the resolution, the presence of advanced effects in the screens...).

3. After RIP'ing your file, you can inspect it in the **Bitmap Viewer**.

- a) Click  in the Bitmap Viewer to show the file repeated continuously (in the horizontal and vertical direction).

The seam lines are indicated in green.

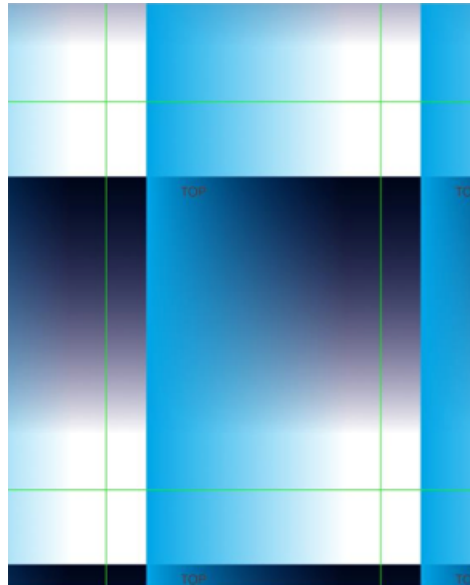

- b) Zoom in on the horizontal seam lines to check that the screening is seamless.

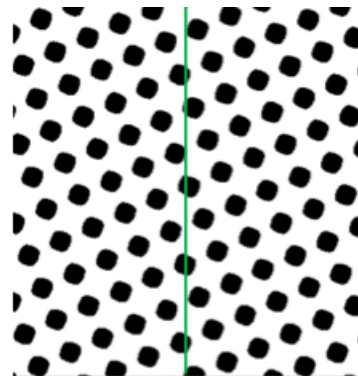
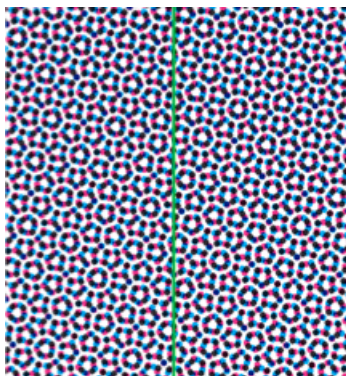

4. If desired, you can also check the exact ruling and angle that were used to make the screen seamless:
- a) Click  in the Bitmap Viewer to open the **Info** window.
  - b) For each separation, you can see the **Ruling, Angle** and **Dot shape** used under **Screens and DGC**.

### Using Advanced Screening Settings

In the **Advanced Screening Settings** dialog, you can set options to modify *your chosen screen*.

1. When working with AM Screening, you can minimize *yellow moiré* by changing the ruling of the yellow separation.



To do this:

- a) In **Change Y Ruling**, select **Yes (conventional)**.

When using a SmartName to set this, it must resolve to `conventional` (or to `no` if you don't want to use yellow moiré reduction).

- b) Choose **by** how much to change the ruling: **-15 %**, **-7 %**, **+7 %** or **+15 %**.

When using a SmartName to set this, it must resolve to `-15`, `-7`, `+7` or `+15`.



**Note:**

- If your file doesn't contain a yellow separation, yellow moiré reduction won't be applied. The task will run as normal but you will get a warning in the log.
- You cannot set yellow moiré reduction options when using a Paragon dot, as Paragon dots already have built-in yellow moiré reduction.



**Tip:**

- If you encounter *four color moiré* when printing with a yellow spot color, or with a light color other than yellow, you can adjust that color's ruling using an *exception*.
- If you want to minimize yellow moiré by changing the yellow screen to a Monet screen (instead of changing the yellow ruling), you can also do this with an exception.

2. In **Screen Angle Direction**, choose how Imaging Engine should read the screening angles (whether you are using *angles from your file*, *default angles* or *specific angles per separation*).

- Choose **Clockwise (FlexRip Compatible)** to read all angles as clockwise.

For example, if you are using the angles from your file, and your file specifies a 75° angle for Cyan, this will be read as 75° clockwise.

If you were previously using FlexRip, we recommend you use this option to get consistent output. This is the default option.

- Choose **Counter Clockwise (Nexus Compatible)** to read all angles as counter clockwise.

In this case, the same 75° Cyan angle from your file will be read as 75° counter clockwise.

If you were previously using Nexus, we recommend you use this option to get consistent output.

- You can use SmartNames resolving to `CW` for clockwise or `CCW` for counter clockwise.



**Note:**

If you use a different angle direction than your screen was designed for, Imaging Engine will create a custom screen on-the-fly, based on your original screen and the screen angle direction you chose.

See *The Effect of Changing a Screen's Angle Direction* on page 1376 for details.



**Attention:**

Certain screens can only be used with a clockwise **Screen Angle Direction** (see [Clockwise Only Screens](#) on page 1376).

- If you have selected a counter clockwise direction, you will not be able to select one of those screens.
- If you select one of those screens, then select a counter clockwise angle direction, you will get a warning that this screen doesn't support counter clockwise angles and that the dot will be changed to [Round Fogra](#).

If desired, you can keep your selected screen but change the angle direction back to clockwise by clicking **Cancel** in the **Advanced Screening Settings** dialog.



**Attention:**

When using older **Image to Screened Separations** tickets (saved in a version of Imaging Engine earlier than 14.1.1), the screen angle direction in your output may not be the same as before in certain cases.

See [Screen Angles in Older Tickets](#) on page 1377 for more information.

**3. Choose a Screening Model** if:

- you are using the screening settings *from your input file*,
- your input file contains overlapping objects that have different screens assigned.

The **Screening Model** you choose determines which screen to use for which separation of the overlapping objects.

- Choose **Esko** for screening results similar to what you would have obtained using FlexRip.

If your input file contains images or shadings showing through flat tint objects because of transparencies, the screening of the image or shading will be used for the parts showing through.

For example, the file below contains an image object, with two (yellow) flat tint objects above it. The yellow object on the left is opaque, but the one on the right has a transparency applied, so that the image shows through it.



The input file contains the following screening information: Round Fogra dot for the image, and Rugby dot for the yellow objects.

When RIP'ing this file using the **Esko Screening Model**, you get the following screened file for the Yellow separation:

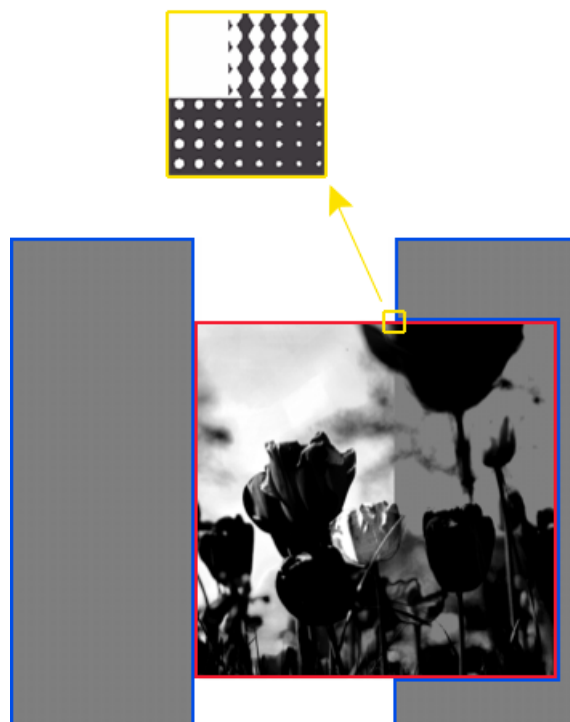

- The area highlighted in red consists of the parts of the image that either don't have another object on top, or have a transparent object on top.

These parts are screened using the screening information of the image object (the Round Fogra dot).

- The areas highlighted in blue consists of the (parts of the) flat tints objects that are either opaque, or that are not on top of the image.

These parts are screened using the screening information of the flat tint objects (the Rugby dot).



**Note:**

- This is the default option when launching a new ticket on your input file(s).
- When re-running old FlexRip jobs using this option, you will get a screening identical to what you used to get with FlexRip in most cases.

In certain particular cases, there are slight differences due to some improvements in the screening model.

See [Imaging Engine - Differences between Esko \(FlexRip compatible\) screening in Imaging Engine and FlexRip](#) in the Knowledge Base for more details.

- Choose **Adobe** for screening results similar to what you would have obtained using Nexus.

If your input file contains overlapping objects that have different screens assigned, the screening of the top object will be used (even in case of images or shadings showing through flat tint objects because of transparencies).

With the same example as above (an image object, with two yellow flat tint objects above it, one opaque and one with a transparency) ...



... you get the following screened file for the Yellow separation when RIP'ing with the **Adobe Screening Model**:

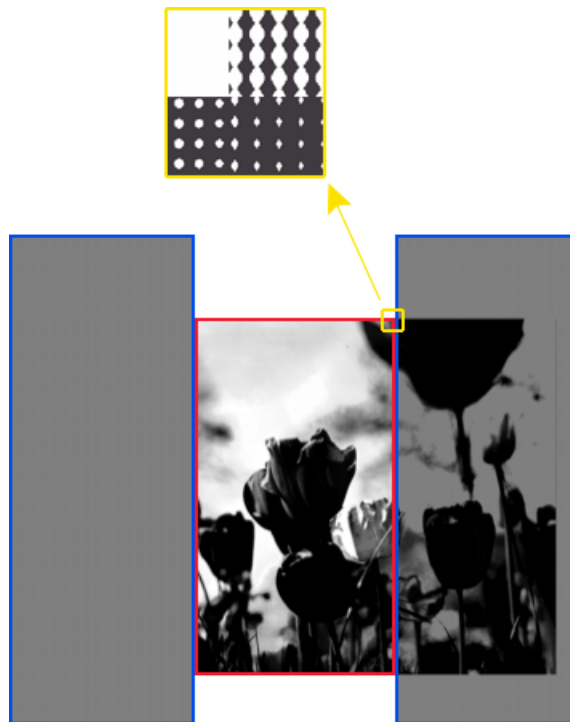

- The area highlighted in red consists of the parts of the image that don't have another object on top.  
These parts are screened using the screening information of the image object (the Round Fogra dot).
- The areas highlighted in blue consists of the flat tints objects that are either on top of the image, or not on top of anything.  
These parts are screened using the screening information of the flat tint objects (the Rugby dot).



**Note:**

- Older versions of Imaging Engine (before 16.0.2) used this screening model by default.  
When using an **Image to Screened Separations** ticket you saved in such an Imaging Engine version, the screening model will be automatically set to **Adobe** to give you consistent results.
- When re-running old Nexus jobs using this option, you will get a screening identical to what you used to get with Nexus in most cases.  
In certain particular cases, there are slight differences due to some improvements in the screening model.  
See [Imaging Engine - Differences between Adobe®\(Nexus compatible\) screening in Imaging Engine and Nexus](#) in the Knowledge Base for more details.

- You can also use a SmartName resolving to Esko or Adobe.

4. Click **Set** to confirm your choices.

### Changing a Screen's Angle Direction

#### The Effect of Changing a Screen's Angle Direction

If you use a *different angle direction* than your screen was designed for, Imaging Engine will create a custom screen on-the-fly, based on your original screen and the screen angle direction you chose.

The way it creates it depends on your type of screen:

- If your original screen only works with angles between 0 and 90° (it is a *modulo 90* screen), the screen will be mirrored along the horizontal axis to produce the other angle direction.

In the example below, a 15° counter clockwise screen angle is mirrored horizontally (along the blue axis) to give a 15° clockwise angle.

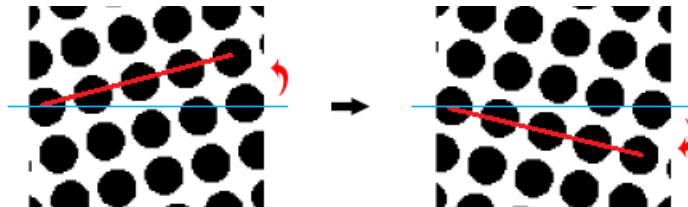

- If your original screen works with angles between 0 and 180° (it is a *modulo 180* screen), the screen angle is simply translated into the other angle direction.

In the example below, a 15° counter clockwise screen angle becomes a 165° clockwise angle.

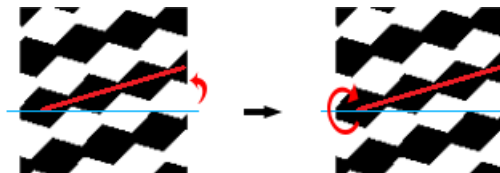

**Note:** You can check the characteristics of a screen in ScreenManager: in the screen details, a modulo 90 screen only lists angles from 0° to 90°, while a modulo 180 screen lists angles from 0° to 180°.

#### Clockwise Only Screens

You cannot change the **Screen Angle Direction** for screens that have the following characteristics:



- they only work with screens angles between 0 and 90° (*modulo 90* screens),
- they contain *surface screening effects*.

When using a screen with a surface screening effect, the pattern frequency and orientation of the effect should be adapted to your inking system (for example, your anilox roll).

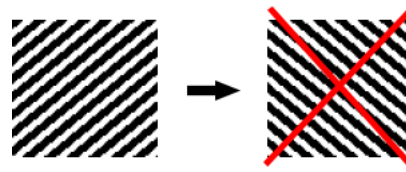
For modulo 90 screens, changing the screen angle direction would change the surface screening pattern's orientation, which would affect how the screen prints.



This applies to the following screens, that were designed for, and can only be used with, a **clockwise angle direction**:

Screen types	Which are clockwise only?
<p><i>Groovy screens</i> (short names: GYY1 to GYY5)</p>	All groovy screens
<p><i>HD Flexo screens</i> (short names starting with HD)</p>	<p>HD Flexo screens that use surface screening effects</p> <p> <b>Note:</b> You can check this in HD Flexo: any screen that mentions <b>Enhanced Shadows and Solids</b> has surface screening effects.</p>
<p><i>Full HD Flexo screens</i> (short names starting with HD)</p>	All Full HD Flexo screens
<p><i>Custom screens created in ScreenManager</i> (short names starting with SCR)</p>	<p>Any custom screen that is modulo 90 and uses surface screening effects</p> <p> <b>Note:</b> You can check the characteristics of a screen in ScreenManager.</p>

**Screen Angles in Older Tickets**

When using older **Image to Screened Separations** tickets (saved in a version of Imaging Engine earlier than 14.1.1), the screen angle direction in your output may not be the same as before in certain cases.

This is because the screen angles are **reinterpreted** according to the [screen angle direction](#) setting (available from Imaging Engine 14.1.1).

**When Will the Angles Stay the Same?**

The screen angles in your output will stay **the same** as before if you **relaunch your old tickets without opening them**.

This is the case when:

- You launch an old ticket on a file using the **Launch with** option in the Pilot (right-click the file in the **Files** view, select **Launch with**, then select your old ticket).
- You run a file through an old workflow containing your old ticket (from the **Pilot**, from **Shuttle**, or from another application connecting to Automation Engine).
- You relaunch an old file with its original ticket settings (right-click the entry corresponding to your old file and ticket in the Pilot's **Tasks** list and select **Relaunch**).

### When May the Angles Change?

If you **open an old ticket** and then launch it on a file, the direction of the screen angles in your output **may be different** from your previous output with that old ticket.

This can be the case when:

- You launch an old ticket on a file using the **New Task** option in the Pilot (right-click the file in the **Files** view, select **New Task**, then select your old ticket; it opens automatically).
- You open the old ticket in the **Tickets** view (next time you launch it on a file, the screen angles in your output may be different).

When opening an old ticket, you will get a message warning you that the *screen angle direction* will be set to **clockwise** by default. This means that Imaging Engine will read all angle values in the files and/or the ticket as being clockwise values.

In most cases, this will give the same output as before, but we recommend you review the following if you are concerned about whether your output will be consistent with previous versions of Imaging Engine:

### Working with Screen Angles from the Input File

If you use the screen angles *defined in your input file*, we recommend you do the following to keep your output consistent with previous versions of Imaging Engine:

- Use a **clockwise** *screen angle direction* if you work with **Normalized PDF** files.
- Use a **counter clockwise** screen angle direction if you work with **standard PDF** files.

Otherwise, you may get different output than previously, as illustrated by the example below:

Input file	Output in older Imaging Engine versions	Output in Imaging Engine 14.1.1 onwards
<b>Normalized PDF file</b> with Cyan at 45°	<p><b>45° clockwise</b>, which could be displayed in the ticket as either:</p> <ul style="list-style-type: none"> <li>• 45° clockwise</li> <li>• 135° counter clockwise</li> </ul> <p>... depending on what you chose in the Preferences of your old Imaging Engine version.</p>	<p>For both <b>Normalized PDF</b> and <b>standard PDF</b> files:</p> <ul style="list-style-type: none"> <li>• <b>45° clockwise</b> if you set a clockwise <i>screen angle direction</i>.</li> <li>• <b>45° counter clockwise</b> if you set a counter clockwise screen angle direction.</li> </ul>
<b>Standard PDF file</b> with Cyan at 45°	<p><b>45° counter clockwise</b>, which could be displayed in the ticket as either:</p> <ul style="list-style-type: none"> <li>• 45° counter clockwise</li> <li>• 135° clockwise</li> </ul> <p>... depending on what you chose in the Preferences of your old Imaging Engine version.</p>	

### Working with Default Screen Angles

The *default screen angles* are the angles used for the separations whose screening settings are not:

- taken from the input file,
- defined using an exception.



When reopening an older ticket that used default screen angles for some separations, your output will be:

- the same as before when working with *modulo 180* screens,
- different when working with *modulo 90* screens.

For more details, please see [Angle interpretation: behaviour for existing IE tickets](#) in the [Knowledge Base](#).

### Working with Screen Angles from Exceptions

If you have set your screen angles using *exceptions*, we recommend you choose a **clockwise screen angle direction** to keep your output consistent with previous versions of Imaging Engine.



**Note:**

If you had chosen to display your angles as counter clockwise in the Preferences of your old Imaging Engine version, the angles will look different in your ticket (as the ticket will now display the clockwise equivalent of your angles).

However, the output will be the same.

### Selecting Screening Parameters through Shuttle

To be able to set screening parameters for each ink when submitting an input file *through Shuttle*, do the following:

#### In Your Imaging Engine Ticket

1. Make your ink selection and screening parameters public in one of the following ways:
  - If you have opened your **Image to Screened Separations** ticket without an input file, you can either:
    - Go to **Advanced > Manage Public Parameters...**, find the **Ink and Screening Selection** parameter at the bottom of the list, and drag it to the right hand side.

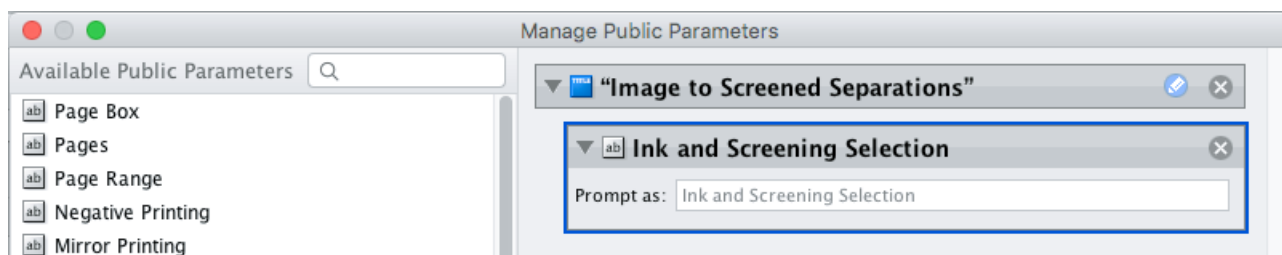

- Go to the **Exceptions** tab, right click the rules table at the top, and choose **Make Parameter Public**.



**Note:** You will not be able to create rules using Shuttle, you will only be able to select inks and screening parameters manually.

- Use the **Inks** tab (see [Selecting Inks through Shuttle](#) on page 1348 for details).
- If you have opened your **Image to Screened Separations** ticket on an input file (even a dummy file), you use any of the above options, or:

- Go to either the **Separations** tab or the **Exceptions** tab, right click the preview table at the bottom, and choose **Make Parameter Public**.
2. By default, the public parameter that appears in Shuttle will be called **Ink and Screening Selection**. You can change its name by:
    - right-clicking one of the elements mentioned above, selecting **Modify Public Parameter** and entering a new name,
    - if you are using the **Manage Public Parameters** window, entering the new name in **Prompt as**.
  3. Make sure your ticket is also **Public**.

**In Shuttle**

The ink selection and screening parameters may look a bit different depending on which Shuttle you are using (the Shuttle standalone application or a Shuttle plug-in in an Editor application).

- In the Shuttle standalone, they will look like this:

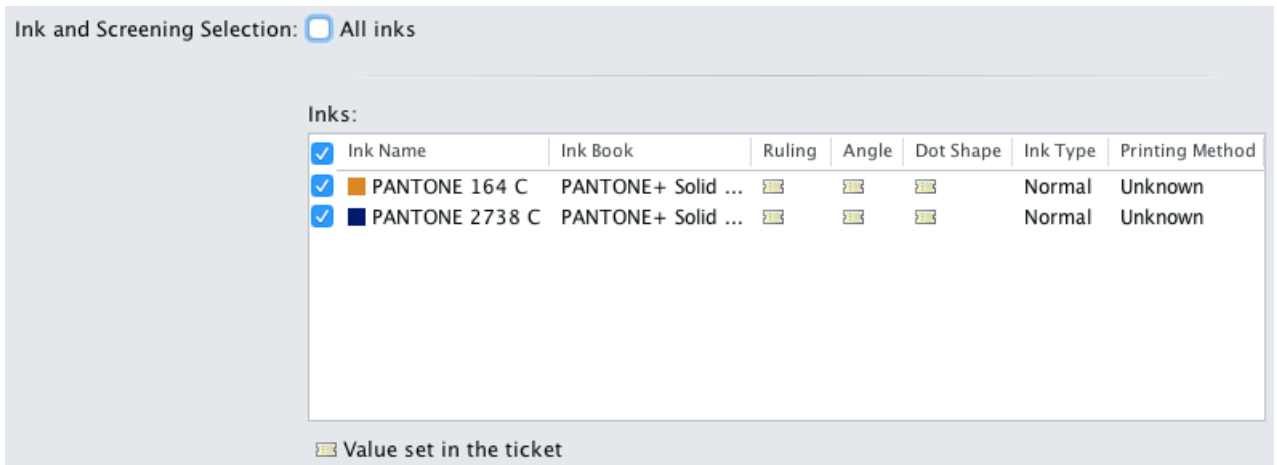

The table shows a preview of all inks in the input file, with their characteristics, and the screening parameters that will be used for each ink.

You can decide which inks to RIP, and with which parameters:

- To RIP all inks from your input file, either leave all inks selected in the preview table, or select **All inks** at the top (this will hide the preview table).
- To only RIP certain inks, make sure **All inks** is not selected, and deselect the input inks that you don't want to RIP.

By default, the screening parameters saved in the ticket are used, but you can change this by clicking the ticket icon and entering the value you want to use.

You can enter values for the **Ruling**, **Angle** and **Dot Shape** as you would in the [Separations tab](#).

- In ArtPro for example, the ink selection and screening parameters will look like this:

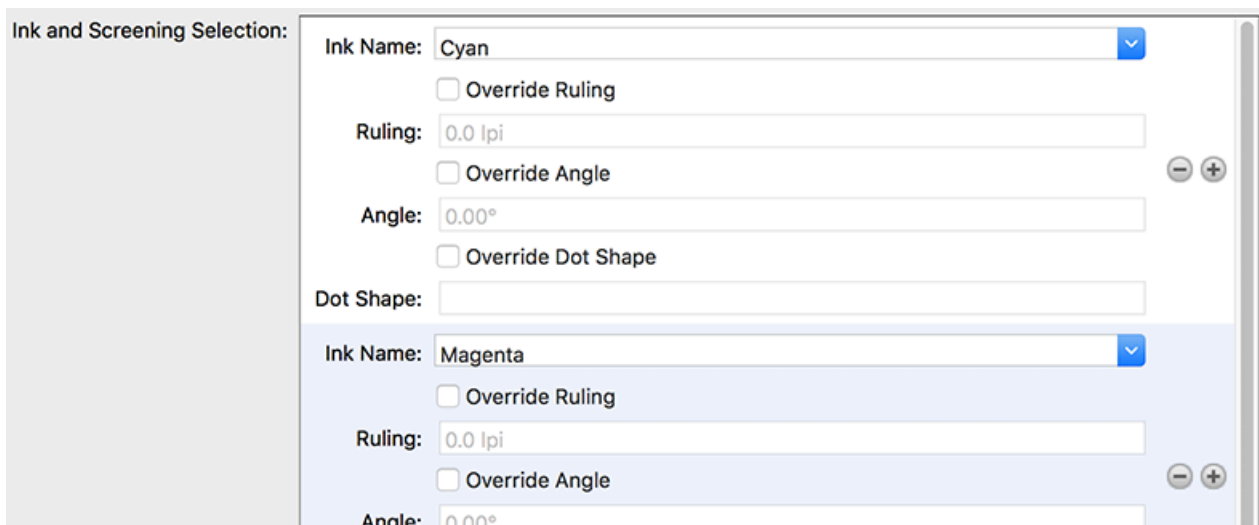

By default, all the inks from your input file will be RIP'ed, but you can remove any ink you don't want to RIP using the  button.

By default, the screening parameters saved in the ticket are used, but you can change this by selecting **Override (Parameter Name)** and entering the value you want to use.

### Corrections

If you notice a specific dot gain related problem in your job, you can use the **Corrections** settings to compensate for that problem without changing your [general dot gain compensation settings](#) (that you may also use for other jobs).

You can:

- apply a correction curve,
- correct dot gain problems in the highlights,
- correct dot gain problems in the shadows.



**Note:**

The corrections you define here are applied to all output separations. If you need to apply a different correction to a specific separation, we recommend you create a **curve strategy** in Curve Pilot for this purpose.

When doing this, the tools in Curve Pilot help you keep your gray balance in check when changing the dot gain compensation for specific separations.

Please see the [Curve Pilot documentation](#) for more information.

1. If needed, select a **Correction Curve** to apply to all the separations that will be output.

You can use this for example to handle press fluctuations, or to modify the transition point when using [transitional screens](#).

- **None** if you don't want to apply any plate curve.
- **Single Curve** if you want to apply one curve for all separations.

In this case, select the `.dgc` curve to apply at right. You can choose from a list of curves available in the curves database.

- **Curve Strategy** if you want to apply a curve strategy (a file created in Curve Pilot that contains several curves to apply in different cases: it can have different curves per separation, dot shape, ruling, for continuous tone images or line work...).

In this case, select the `.icpro` curve strategy or legacy `.srdgc` screen-based DGC file to apply at right.

You can choose from a list of curve strategies available in the curves database.



**Note:** In case you select the option **Curve Strategy**, the option **Range Correction** (see below) will not be available or applied. Also if a SmartName resolves to a `.icpro` or `.srdgc` file any Range Correction defined will not be applied.

For more information, see:

- [Dot Gain Compensation Curves](#) on page 1220,
- [DGC Curve Strategies](#) on page 1221,
- [The Curves Database](#) on page 1224.



**Note:** You can use SmartNames resolving to the exact name of the Single Curve or Curve Strategy (including the extension). In the ticket, this will set the Correction Curve type to Unknown, but it will resolve to the correct curve type if the SmartNames are correct.

2. Choose when to **Apply the Correction Curve**:

- **Before Press Curve**
- **Between Press & Plate Curve**
- **After Plate Curve**
- you can also use a SmartName resolving to `BeforePress`, `BetweenPressAndPlate` or `AfterPlate`.

The order in which you apply your dot gain compensation curves makes a difference to your final result. In the example below, you can see what happens to the 50% value depending on the order of the curves:

- When applying the correction curve first (**Before Press Curve**):
  1. The **Correction Curve** changes the initial 50% value to 60%.

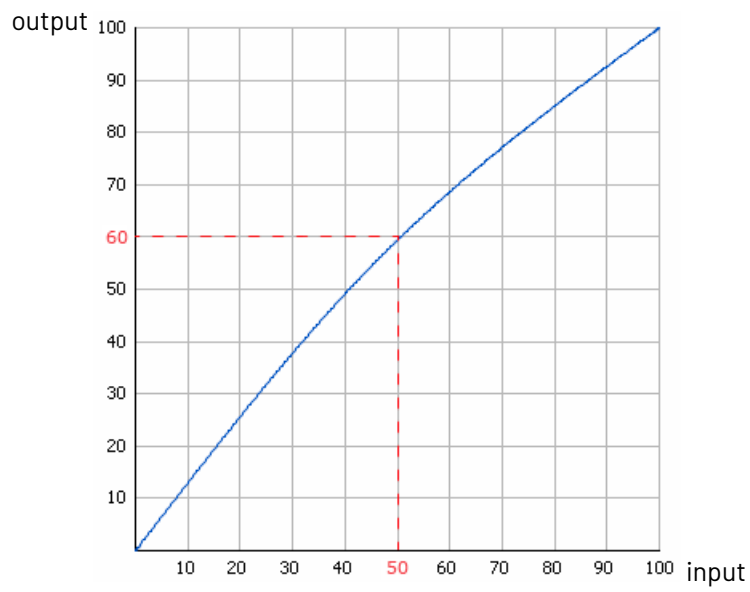

2. For that 60% value, the **Press Curve** gives 48%.

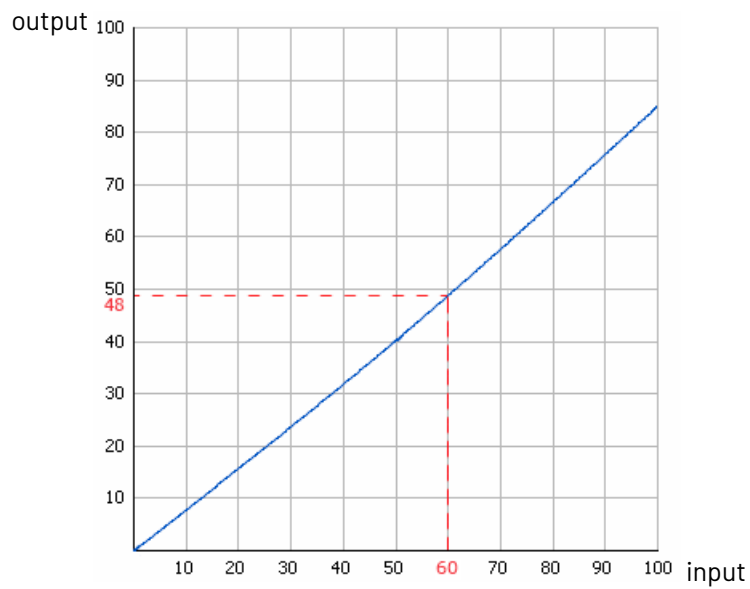

3. For that 48% value, the **Plate Curve** gives a final value of **53%**.

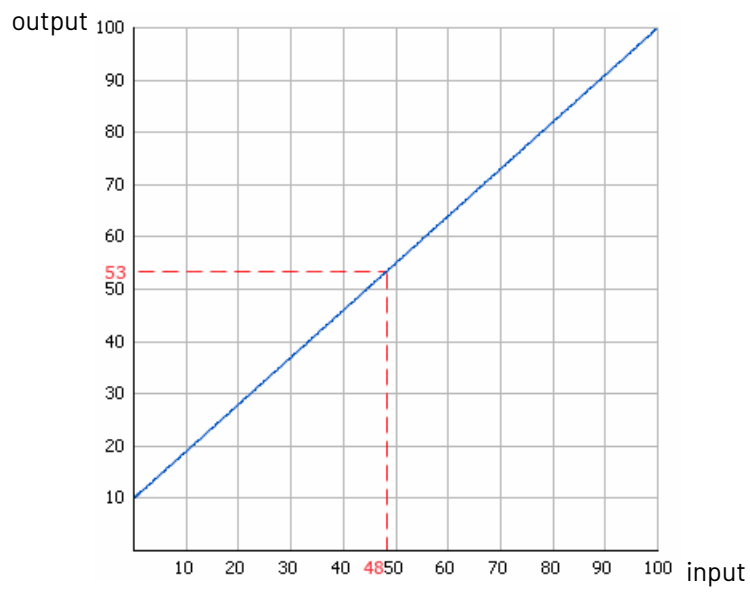

- When applying the correction curve **Between Press & Plate Curve**:

1. The **Press Curve** changes the initial 50% value to 40%.

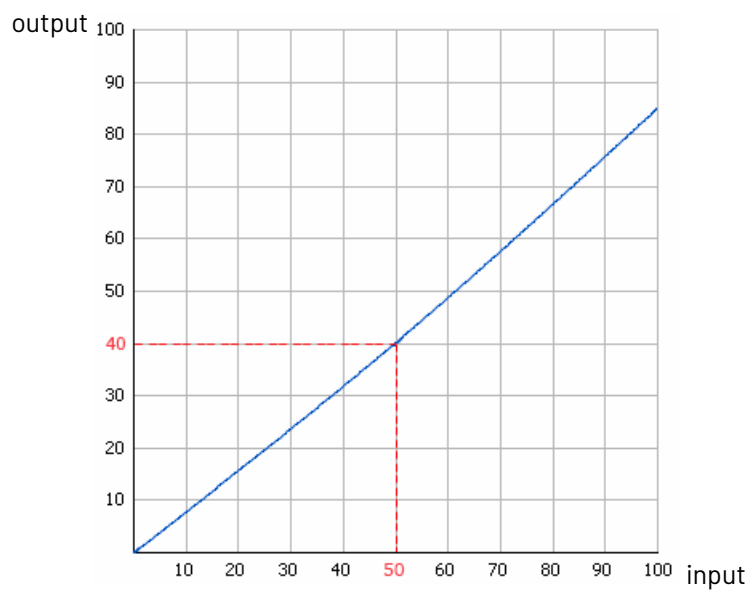

2. For that 40% value, the **Correction Curve** gives 49%.

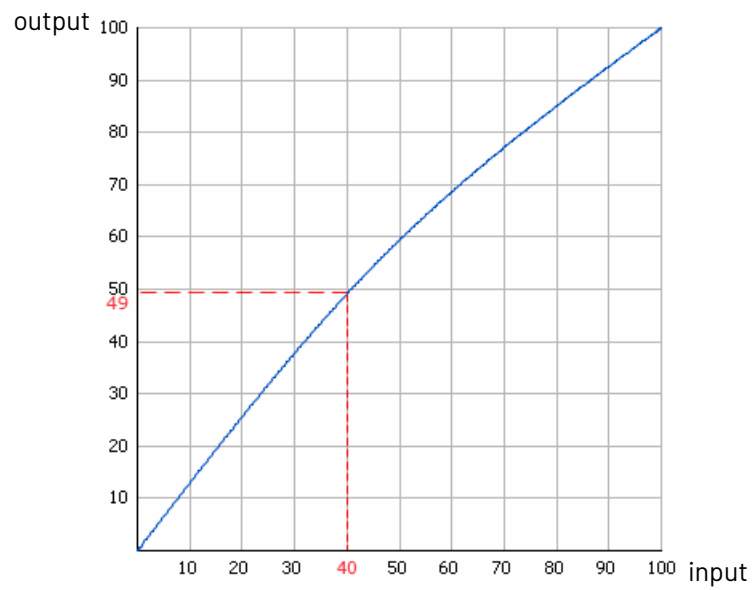

3. For that 49% value, the **Plate Curve** gives a final value of **54%**.

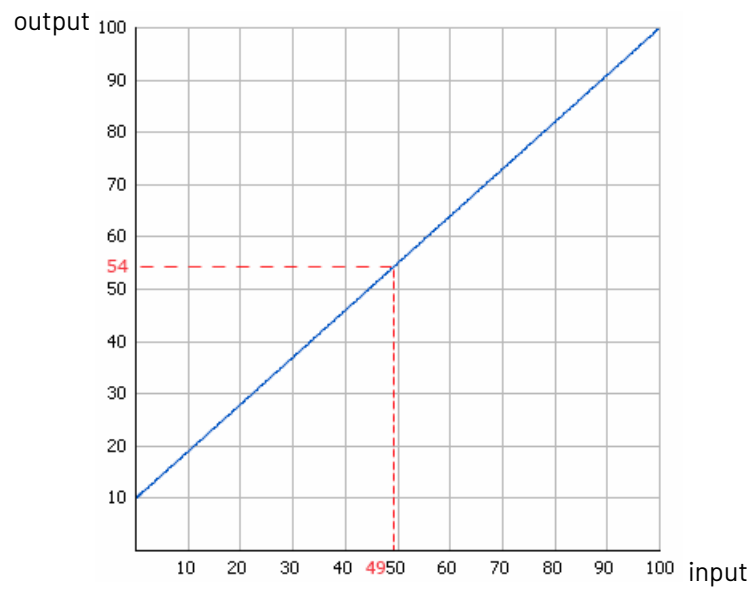

- When applying the correction curve last (**After Plate Curve**):
  1. The **Press Curve** changes the initial 50% value to 40%.

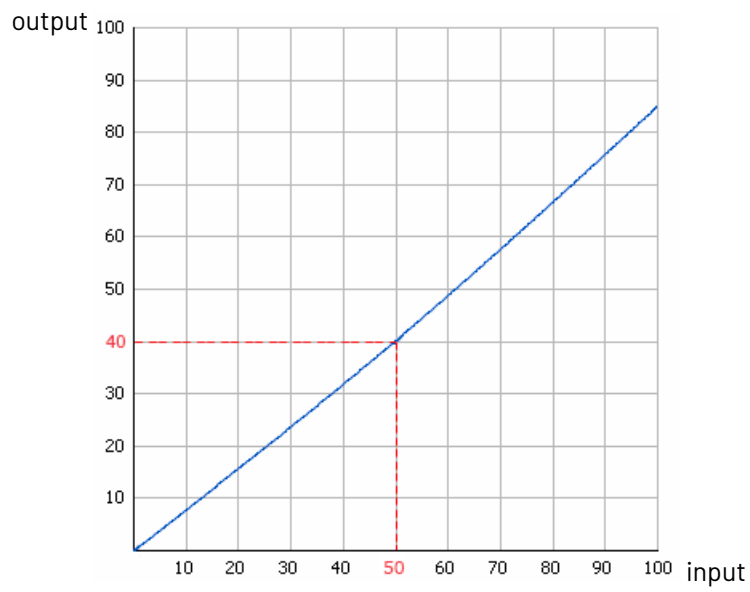

2. For that 40% value, the **Plate Curve** gives 46%.

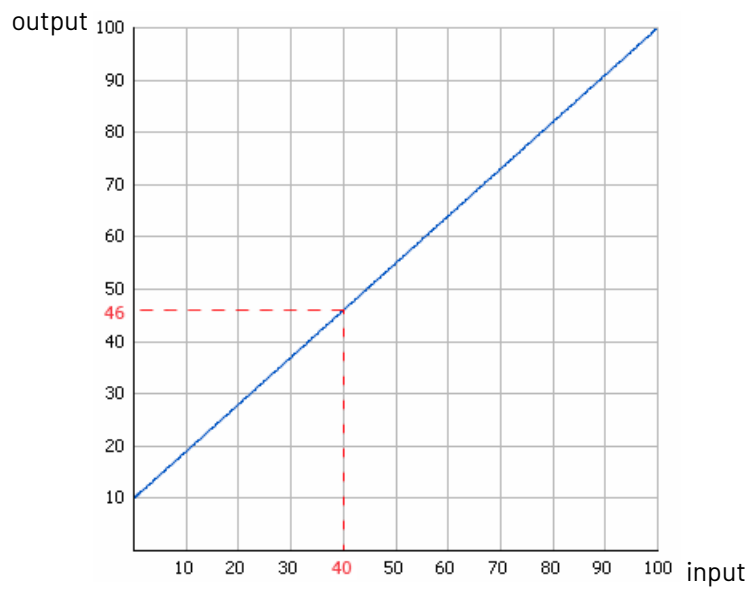

3. For that 46% value, the **Correction Curve** gives a final value of **56%**.



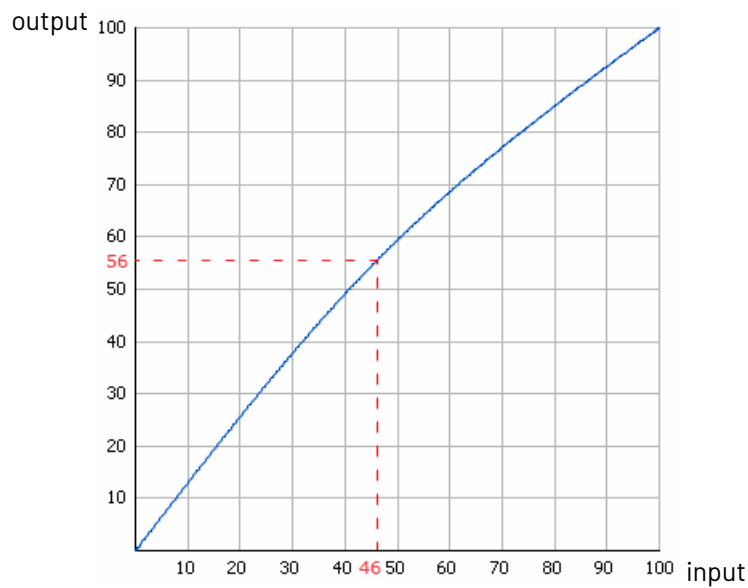

3. After your curves have been applied, you can also use the **Range Correction** to correct dot gain problems in the highlights and/or shadows.
  - Select **Minimum Correction** if you only want to correct the highlights.
  - Select **Maximum Correction** if you only want to correct the shadows.
  - Select **Minimum & Maximum Correction** if you want to correct both highlights and shadows.
  - You can also use a SmartName resolving to `Minimum`, `Maximum` or `MinimumAndMaximum`.



**Note:**

- If you have already applied a highlights and/or shadows correction in your *plate curve* or *default press curve* you don't need to make that correction again here.
- Correcting your highlights and/or shadows does not affect your mid-tones. If you want to correct your mid-tones, you can use a correction curve.

4. If you have problems with the highlights (for example they print unevenly, giving you missing or partial dots), you can do the following to correct them:
  - a) Enter the **Minimum Dot** that you know your plate can safely print. In the screened files, Imaging Engine will not generate dots any smaller than what you enter here.



**Note:**

- The **Minimum Dot** must be within the 0%-30% range. If you enter a percentage outside of this range it will be automatically adjusted to the nearest value in the range (for example 32 will be adjusted to 30%).
- When using a SmartName, it must resolve to a number between 0 and 30 (without the % sign). If you use a SmartName that resolves to a percentage outside the range, the task will end in error.
- You can enter a simple formula and it will be calculated automatically (for example you can enter 10+2 and this will be changed to 12%). This only works with numerical values and not with SmartNames.

b) In **How to Handle Minimum Job Tones**, enter the range of input file tones that typically gives you problems on output (for example, you may find that tones between 0% and 1% in your input file typically give you missing or partial dots on output).



**Note:**

- The **Minimum Job Tones** range always starts at 0% and can go up to 10%. If you enter a percentage outside of this range it will be automatically adjusted to the nearest value in the range.
- When using a SmartName, it must resolve to a number between 0 and 10 (without the % sign). If you use a SmartName that resolves to a percentage outside the range, the task will end in error.
- You can enter a simple formula and it will be calculated automatically. This only works with numerical values and not with SmartNames.

c) Decide how to treat this range of problematic tones to prevent output problems. You can either:

- Not print those small percentages (select **Drop To 0%**).

In this case, anything in that range will be rendered at 0% (so removed from the output), and the first percentage above that will become the **Minimum Dot**.

In the example below, the **Minimum Job Tones** are 0% to 5% and the **Minimum Dot** is 10%.

If you select **Drop To 0%**, the 0% to 5% range in your input file becomes 0% in the output, and the first percentage after that (5.01%) becomes 10% (the **Minimum Dot**).

Higher percentages follow the dot gain compensation you applied (the combination of the plate curve, press curve and correction curve you have set). Note that the transition between your highlights correction and the combined curve is smoothed to give you better printing results.

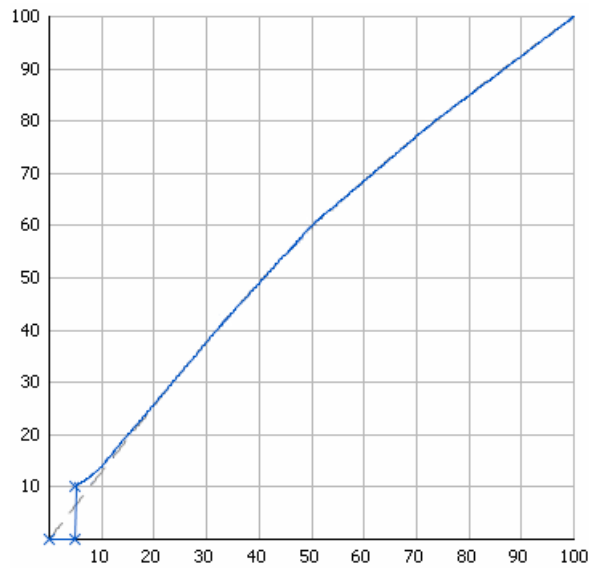

- Increase those small percentages so they meet the threshold to become your **Minimum Dot** on output (select **Hold To Minimum Dot**).

In this case, anything in that range (except 0%) will be rendered at the percentage you entered as **Minimum Dot**.

With the same example, if you select **Hold To Minimum Dot**, 0% will stay 0%, and the 0.01% to 5% range in your input file will become 10% in the output (the **Minimum Dot**).

Higher percentages follow the dot gain compensation you applied (the combination of the plate curve, press curve and correction curve you have set). Note that the transition between your highlights correction and the combined curve is smoothed to give you better printing results.

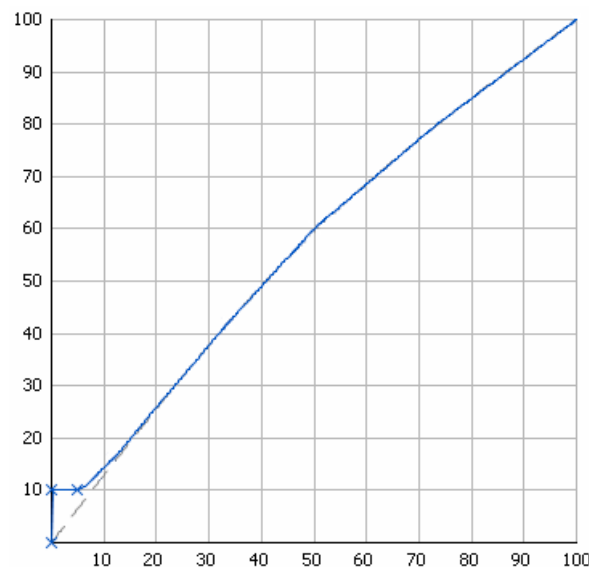

5. If you have problems with the shadows (for example you lose detail in the darkest areas, or you get *pin holes* in the solids from laying down too much ink), you can do the following to correct them:
- Enter the **Maximum Dot** that you know you can safely print for a good result in the shadows. In the screened file, Imaging Engine will not generate dots any bigger than what you enter here.



**Note:**

- The **Maximum Dot** must be within the 70%-100% range. If you enter a percentage outside of this range it will be automatically adjusted to the nearest value in the range (for example 68 will be adjusted to 70%).
- When using a SmartName, it must resolve to a number between 70 and 100 (without the % sign). If you use a SmartName that resolves to a percentage outside the range, the task will end in error.
- You can enter a simple formula and it will be calculated automatically (for example you can enter 70+5 and this will be changed to 75%). This only works with numerical values and not with SmartNames.

- In **How to Handle Maximum Job Tones**, enter the range of input file tones that typically gives you problems on output (for example, you may find that tones between 97% and 100% don't show enough details on output).



**Note:**

- The **Maximum Job Tones** range can start from 90% and always go up to 100%. If you enter a percentage outside of this range it will be automatically adjusted to the nearest value in the range.
- When using a SmartName, it must resolve to a number between 90 and 100 (without the % sign). If you use a SmartName that resolves to a percentage outside the range, the task will end in error.
- You can enter a simple formula and it will be calculated automatically. This only works with numerical values and not with SmartNames.

- Decide how to treat this range of problematic tones to prevent output problems. You can either:
  - Make those large percentages solid (select **Raise To 100%**).

In this case, anything in that range will be rendered at 100%, and the first percentage below that range will become the **Maximum Dot**.

In the example below, the **Maximum Job Tones** are 95% to 100% and the **Maximum Dot** is 90%.

If you select **Raise To 100%**, the 95% to 100% range in your input file becomes 100% in the output, and the first percentage below that (94.99%) becomes 90% (the **Maximum Dot**).

Lower percentages follow the dot gain compensation you applied (the combination of the plate curve, press curve and correction curve you have set). Note that the transition between the combined curve and your shadows correction is smoothed to give you better printing results.

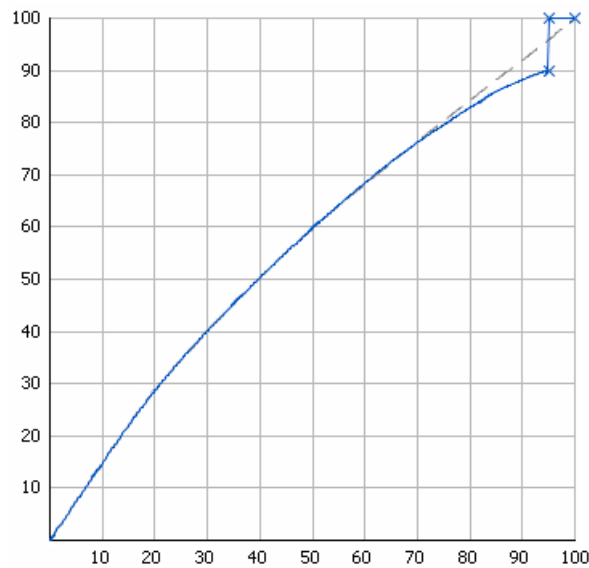

You can use this if you don't want your darkest shadows to be screened (for files containing linework for example).

- Decrease those large percentages so they become your **Maximum Dot** on output (select **Hold To Maximum Dot**).

In this case, anything in that range (including 100%) will be rendered at the percentage you entered as **Maximum Dot**.

With the same example, if you select **Hold To Maximum Dot**, the 95% to 100% range in your input file will become 90% in the output (the **Maximum Dot**).

Lower percentages follow the dot gain compensation you applied (the combination of the plate curve, press curve and correction curve you have set). Note that the transition between the combined curve and your shadows correction is smoothed to give you better printing results.

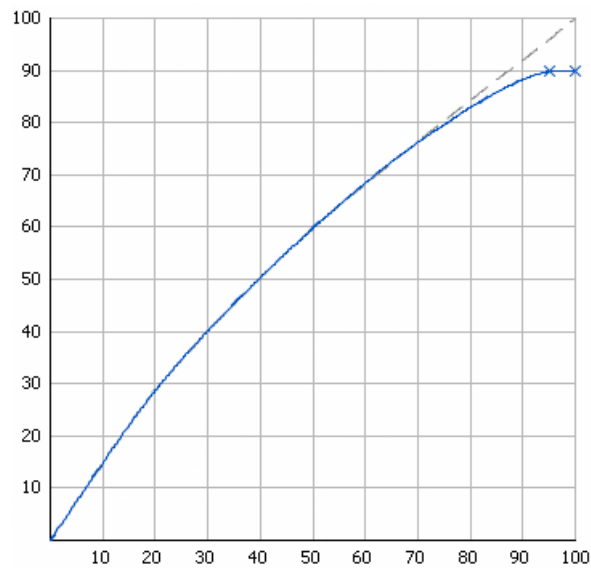

You can use this if you want your darkest shadows to be screened (for files containing images for example).

6. You can see the number of corrections you applied next to the **Corrections** tab at left.

For example, if you apply a **Correction Curve**, a **Minimum Correction** (on the highlights), and a **Maximum Correction** (on the shadows), you will see **Corrections (3)**.

**Exceptions**

Use the **Exceptions** tab if you want to always apply specific screening and dot gain compensation settings to certain separations (for example spot colors).

These specific settings overrule your more general screening and dot gain compensation settings (for example, you can apply a *default press curve* to your input file, but choose to use a different press curve for a specific separation).

You can do this anytime (when launching the task on one or more input files, when defining ticket settings, when setting up a workflow...).

You do this by setting up **rules**. This works as follows:

- You create a rule for each separation or set of separations that need specific screening and/or dot gain compensation settings.
- Within each rule:
  1. You select the separation(s) you want to apply specific settings to. You do this by setting criteria that a separation has to match to be selected.

For example if you want to select all process inks, you can set that the ink book must be `process` for the inks to be selected.

You can use the following ink characteristics in your criteria:

<b>Ink name</b>	
<b>Ink book</b>	

<p><b>Ink index</b></p>	<p>The <b>Ink index</b> is the order in which the file's inks will be printed (the ink with ink index 1 is at the bottom of the document and will be printed first).</p> <p>To find the ink index of a file:</p> <ol style="list-style-type: none"> <li>1. select the file in the Automation Engine Pilot's <b>Files</b> view,</li> <li>2. click ,</li> <li>3. in the <b>Info</b> dialog that opens, select <b>Inks</b> in the left panel.</li> </ol> <p>The order of the inks at right is the ink index (the topmost ink has an index of 1, the second of 2, etc.).</p> <p>Note that if you reorder the inks by one of the columns (for example by <b>Ink name</b>), they won't be ordered by ink index anymore. You will need to close that dialog and reopen it to see the ink index order again.</p>
<p><b>Spot ink index</b></p>	<p>The <b>Spot ink index</b> is the order in which a spot ink will be printed (when counting only spot inks and not process inks).</p> <p>For example, if the first 4 inks of the document are CMYK, the first spot ink will have 5 as <b>Ink index</b> but 1 as <b>Spot ink index</b>.</p>
<p><b>Ink type</b></p>	<p>This can be for example <i>Normal, Technical, Varnish...</i></p>
<p><b>Printing method</b></p>	<p>If you have set a <b>Printing method</b> for an ink it will be shown here (this can be for example <i>Offset, Gravure, Flexo...</i> or any custom printing method you configured).</p> <p>See the Automation Engine documentation for more information about printing methods.</p>

2. You define the screening and/or dot gain compensation settings to apply to the selected separation(s).

- If you have several rules, you can reorder them in order of priority (the top one is applied first).

To define a rule manually, you need to do the following in the **Exceptions** tab:

1. Click **+** at the bottom of the table.
2. In the **Rules Properties** dialog, enter a **Rule Name**.
3. Under **If separation matches**, define one or more criteria to select your desired separation(s).

You can use the following elements:

- **Ink name:** you can define if it **contains/begins with/ends with/is** a piece of text (alphanumerical characters), or if it **is empty**.
- **Ink book:** you can define if it **contains/begins with/ends with/is** a piece of text (alphanumerical characters), or if it **is empty**.
- **Ink index:** you can define if it **equals/is less than/is greater than** the number you enter, or **is between** the two numbers you enter (in this case the ink indexes you enter as boundaries are also selected).
- **Spot ink index:** you can define if it **equals/is less than/is greater than** the number you enter, or **is between** the two numbers you enter (in this case the spot ink indexes you enter as boundaries are also selected).

- **Ink type:** you can define if it **is** a piece of text (alphanumerical characters).
- **Printing method:** you can define if it **is** a piece of text (alphanumerical characters).



**Tip:**

- You can enter several values to check for: just use a semicolon (;) between them.  
For example, to check for both inks called Cyan and inks called Magenta, choose **Ink name is** and enter Cyan;Magenta.
- Click **+** to add more criteria. You can also add sub-criteria by holding **Alt** while clicking **+**.  
For example, if you want to make a rule for Process Yellow, you can use:  
**All of the following are true:**  
**Ink name is** Yellow  
**Ink book is** Process
- When launching the task on a file, you can also click  to select one or more of the **Ink names/Ink books/Ink types/Printing methods** used in your input file(s).  
A criterion will automatically be created based on your selection.

4. Define the settings (**Dot, Ruling, Angle** and/or **Press Curve**) you want to use for the selected separation(s).



**Note:** If you enter a **Ruling** or **Angle** value that is not valid for the separation's **Dot** shape, Imaging Engine will change it to the closest valid ruling or angle when RIP'ing.

5. Click **Add**.

You can see your rule and the settings you defined for the selected separation(s) in the **Exceptions** tab table.



**Tip:** You can double-click your rule if you still want to edit it.



**Note:**

If you have defined specific settings for certain separations *manually* (when launching the task on a single file), you can see that these settings have been automatically added as rules in the **Exceptions** tab (and shown in italics).

A rule is added for each setting that you define (for example if you select a specific **Dot** and **Press Curve** for Yellow, you will get one rule for the dot and one for the press curve).

6. Repeat steps 1 to 5 to define more rules if desired.

If you want to remove a rule, select it and click **Remove**.

You can see the number of rules defined next to the **Exceptions** tab at left.

7. If desired, you can reorder your rules (they are applied from top to bottom). To do this, select a rule and click **Move Up** or **Move Down** (or drag it up or down).



8. When launching the task on a single file, you can see the file's separations and the settings that will be applied to them in a table (make sure to leave the **Preview** option selected).

This is the same table as at the bottom of the *Separations* tab. It includes:

- the settings you have *taken from the input file*,
- the settings you have *defined for all separations*,
- the settings you have defined *for specific separations*,
- the settings defined by your exception rules.

As in the **Separations** tab, you can use this table to define specific screening and dot gain compensation settings for certain separations.

Click in the **Dot**, **Ruling**, **Angle** or **Press Curve** column, and enter/select the value you want to use for that ink.

Your custom values are shown in italics.



**Note:** If you enter a **Ruling** or **Angle** value that is not valid for the separation's **Dot** shape, Imaging Engine will change it to the closest valid ruling or angle when RIP'ing.

If you want to go back to the previous setting, right-click the value you just set and select **Clear Custom Value**.



**Note:**

When launching your Imaging Engine ticket on a file from Automation Engine Shuttle, you cannot see the exceptions defined in the ticket (Shuttle always displays the parameter values found in the input file).

However, if you modify some public parameter values in Shuttle then launch the ticket, when you go to back to the Automation Engine Pilot and open the ticket, you will see all your modified parameters saved as exceptions.

### Post-RIP

When a job is RIP'ed with screening, it can happen that very small or broken dots (sometimes called "scum dots") appear in highlight areas.

These dots can be smaller than the minimum dot size that can be held on a flexo plate, which can cause "dragging" and other unwanted effects when the job is printed.

You can use **Post-RIP** settings to clean up areas of the output files where:

- Halftone dots are smaller than a certain minimum dot size.
- *Advanced screening effects* like support dots and surface screening patterns are broken or different from the intended pattern.

This is typically the result of a resolution mismatch between the input file and the screen ruling applied.



**Note:** The **Post-RIP** tab is only available if you have a dot clean up license.

The cleanup algorithm adapts itself to the screen(s) used by the task:

- For screens with surface screening effects (micro-cells, patterns or line perforations in dots and solids to improve ink lay-down), dot cleanup will preserve the surface screening.
- For screens with support dots (non-printing pixels that support isolated printing dots), dot cleanup will replace pixel residues by a supporting dot.
- For screens with *Pixel+* pixels used to form halftone dots (Crystal screens), dot cleanup will preserve the isolated pixels and the minimum dot size will be interpreted as the minimum number of isolated *Pixel+* pixels.



**Note:**

If you are using *Crystal screens* and generating *print simulation files*, you will be able to see differences between the LENX files (with the Crystal screens) and their print simulation files after dot cleanup.

This is because print simulation files are meant to show the final result (after boosting on the CDI if they are previews of LENX files), so they do not use *Pixel+* pixels but simulate the final screening with AM screens. Screens using *Pixel+* and AM screens are cleaned up differently.

See [this knowledge base article](#) for more information.



**Note:** If the task also contains a *minimum dot correction* set in the **Separations > Corrections** tab, both actions will be performed independently; the post-RIP dot cleanup will be performed last.

1. Select **Clean up scum dots**.
2. You can see all your input file's separations in the table below, with some default dot cleanup settings.



**Note:**

If you are *using a printing condition*, **Clean up scum dots** is selected by default, and the clean up settings are calculated based on your printing condition's screen(s).

By default, white is not cleaned up (as this could interfere with the specific surface screening patterns that can be used for the white separation).

3. Select the separations that you want to clean up, deselect those that you don't.  
You can also **Deselect All** or **Select All** separations.
4. To edit a separation's dot clean up parameters:
  - a) Double-click that separation's row in the table.
  - b) In the **Clean up Scum Dots** pop-up that opens, leave **Clean up scum dots** selected.
  - c) Depending on the type of screening used for this separation, you should either:
    - do a simple clean up (for most screens); see [Simple Clean up](#) on page 1397,
    - do an advanced clean up (for Print Control Wizard screens containing transitional dots - like in High Quality Corrugated printing conditions-, or for separations with object based screening); see [Advanced Clean up](#) on page 1397.
  - d) When you are done, click either **Apply** (to this separation only) or **Apply to all separations**.
5. If needed, you can set different dot clean up parameters for other separations.

### Simple Clean up

For most screens, you can do a simple clean up to remove the scum dots. If you are working with Print Control Wizard screens containing transitional dots, or separations with object based screening, you should do an [advanced clean up](#) instead.

The simple clean up targets small isolated dots, which means small dots that don't have neighboring dots within a certain distance, as these dots are not likely to print in a stable way.

Using a neighboring distance ensures that the clean up doesn't interfere with support dots.

1. In **Dot Sizes Smaller than**, enter the minimum dot size that you want to keep.

You can enter this dot size in pixels, percentage or microns. A SmartName defining the dot size unit must resolve to %, pixels, or  $\mu\text{m}$ .

All dots smaller than this size will be examined, and cleaned up if necessary.



**Note:**

- If you are using a [printing condition](#), this is the minimum dot size used in the screen from your printing condition.
- For **HD Flexo** or **Full HD Flexo** screens which use highlights or a minimum dot size, enter the minimum dot size for that screen.  
  
For example, for an HD Flexo screen whose name contains "C16", you should enter 16 pixels.

2. In **Distance**, enter the distance within which there should be another dot.

If your small dots (smaller than your specified dot size) don't have another dot within this distance, they will be cleaned up.



**Note:**

Versions of Imaging Engine older than 21.11 used a **Ruling** parameter instead of the **Distance**.

If you have upgraded from an older version, you can see that the pop-up gives an equivalent ruling for the distance you enter here, and you can compare it to the ruling in your older tickets, if necessary.

### Advanced Clean up

If you are working with Print Control Wizard screens containing transitional dots (like in High Quality Corrugated printing conditions), or separations with object based screening, you should do an advanced clean up (otherwise you can do a [simple clean up](#) instead).

For the advanced clean up we are not only considering one dot size and distance like for the simple clean up, but we are working with a range of sizes and distances.

1. Select **Vary distance with dot size**.
2. In **Dot Sizes Smaller than**, you need to enter two sizes:
  - The **smaller size** should be the absolute minimum dot size that you want to keep.

For Print Control Wizard screens containing transitional dots, this should be the size of your **transitional dot**.

For separations with object based screening, this should be the size of the **smallest mindot** out of the different screens you are using.

- The **larger size** should be the size after which dots don't need to be cleaned up (from this size, they should not be scum dots but regular sized dots that will print well).

For Print Control Wizard screens containing transitional dots, this should be the size of your **regular mindot**.

For separations with object based screening, this should be the size of the **largest mindot** out of the different screens you are using.

You can enter these dot sizes in pixels, percentage or microns. A SmartName defining the dot size unit must resolve to %, pixels, or  $\mu\text{m}$ .

**3. In Distance**, enter two neighboring distances, corresponding to your two dot sizes.

- Dots of your **smaller dot size** should have a neighboring dot within the **smaller distance**, otherwise they will be cleaned up.
- Dots of your **larger dot size** should have a neighboring dot within the **larger distance**, otherwise they will be cleaned up.
- The neighboring distance **increases with the dot size**: for example if your 2px dots need to have a neighbor within 0.4mm, and your 4px dots need one within 0.8mm, then your 3px dots need one within 0.6mm.
- Dots smaller than your smaller dot size will **always be cleaned up**.



**Note:**

Versions of Imaging Engine older than 21.11 used a **Ruling** parameter instead of the **Distance**.

If you have upgraded from an older version, you can see that the pop-up gives an equivalent ruling for the distance you enter here, and you can compare it to the ruling in your older tickets, if necessary.

**Summary**

This shows a summary of all the settings you defined in the ticket.

- To show the settings from a tab, click + (on PC) or ► (on Mac) beside the tab name in the right pane. Click **Expand All** to show the settings from all tabs.
- To hide the settings from a tab, click - (on PC) or ▼ (on Mac) beside the tab name in the right pane.

Click **Collapse All** to hide the settings from all tabs.

### 16.5.5. Image to Unscreened Separations

Use this task if you need unscreened output to send to a device that will take care of the screening, or a device that doesn't need screened input (for gravure for example).

#### Task Output

The **Image to Unscreened Separations** task generates one file per separation, in either [PDF](#) or [TIFF format](#).

In the example below, processing a file containing the lime green Esko star generates unscreened files for the Cyan, Yellow and Black separations.



#### Task Parameters

In the **Device** field, select the imaging device [that you configured](#).

Then use the tabs at left to show more settings to fill in. See:

- [General](#) on page 1399,
- [Transformations](#) on page 1401,
- [PDF Objects](#) on page 1402,
- [Processing Steps](#) on page 1404
- [Inks](#) on page 1408,
- [File Output](#) on page 1415,
- [Separations](#) on page 1424,
- [Summary](#) on page 1439.

#### General

1. Define what **Page Box** of the input PDF you want to RIP.

You can either select **Media Box**, **Trim Box**, or insert a SmartName  that must resolve to either `media` or `trim`.

After selecting your file's page box you will see its dimensions under the **Page Box** option.

2. If your input file is a multi-page PDF, select which **Pages** you want to RIP:
  - a) First select **All pages**, **Odd pages only** or **Even pages only** in the **Pages** option.

You can also insert a SmartName resolving to either `All`, `Even` or `Odd`.

- b) Then you can refine your selection by entering page numbers or a **Page Range**.

You can separate page numbers by a comma, or use a dash to indicate a page range (for example 3, 6–9). You can also use a SmartName resolving to page numbers and/or page ranges using this same format.



**Note:**

- Page numbers are always physical pages. If your document starts with page 5, you should not use 5 but 1 to get the first page.
- If you enter page numbers that are not part of your document, they will be excluded from the output (all the other valid pages will be RIP'ed).
- If you enter the same page(s) more than once (for example 1, 1–2), it/they will only be output once.
- Pages are RIP'ed in the order of the document (entering 5–1 will be automatically changed to 1–5).

3. If you want to invert your output so it is compatible with the output device or software system that will process it, click .

You can also click or **Edit...** to insert a SmartName that must resolve to 1 or `true` (to invert the output), or to 0 or `false` (to leave the output as it is).

4. If you want to mirror your output so it is compatible with the output device or software system that will process it, click .

You can also click or **Edit...** to insert a SmartName that must resolve to 1 or `true` (to mirror the output), or to 0 or `false` (to leave the output as it is).

5. If you want to add **SmartMarks (Classic)** or **Dynamic Marks** in your output file(s), select the **Type of Marks** you want to add and then select the specific **Mark Set** you want to use.

**SmartMarks (Classic)** or **Dynamic Marks** are marks whose content is variable, so you can make them display information about that specific job and use them as a production control. For example, you can include some of the parameters used during RIP'ing in your output file(s) by using SmartMarks (Classic) or Dynamic Marks.

You need to:

- a) First create the SmartMarks (Classic) you want to use in **PackEdge** or **Plato** and the Dynamic Marks in **ArtPro+** (see the PackEdge, Plato and Arpro+ manuals for more details).

You can create either:

- a general SmartMark (Classic) or Dynamic Mark (for example a corner mark or split mark),
- a Text Mark with Smart Text, that will display the information included in your input file,
- an Imaging Engine-specific Text Mark with Smart Text, that will display the parameters that you set in the ticket.

To do this, select **Output Parameter** in the **Smart Text** pop-up in the PackEdge/ArtPro + application. Make sure you use the RIP-related SmartMark attributes from the **Output Parameter** category, and not those from the **Ink/Color** category.

If your PackEdge, Plato or ArtPro+ application is linked to your Automation Engine server, your SmartMarks (Classic) or Dynamic Marks will automatically be saved in the correct location and will be available in Imaging Engine.

- b) Then select that SmartMark (Classic) or Dynamic Mark in your **Imaging Engine task** using the **Mark Set** option.

The SmartMarks (Classic) or Dynamic Marks will be added to each output file generated from your input file.

## Transformations

Use the **Transformations** settings to rotate or distort your output relative to your input file.

1. If you want to rotate your file's contents, select the **Rotation** you want to apply here.

This can be:

- **0°**
- **90° Counter Clockwise**
- **180°**
- **90° Clockwise**

Any other value will give an error.





**Note:**

- You can use a SmartName that resolves to 0, 90 (for **90° Counter Clockwise**), 180 or 270 (for **90° Clockwise**).
- You need to use a numerical value (*ninety* will not work).
- This is a public parameter, that you can fill in when submitting files through Shuttle.

2. If you want to apply **Distortion** to your file's contents, select the type of distortion to apply:

- a) **Flexo distortion**

If you want to apply **Flexo distortion**, enter the vertical  and horizontal  distortion percentages to use.

You can enter numerical values, or insert SmartNames that resolve to numerical values (without the % sign).



**Note:**

- The values should be within the 85%-115% range. If you enter a percentage outside of this range it will be automatically adjusted to the nearest value in the range (for example 80 will be adjusted to 85%).  
  
However, if you use a SmartName that resolves to a percentage outside the range, the task will end in error.
- You can enter a simple formula and it will be calculated automatically (for example you can enter `100+2` and this will be changed to `102%`). This only works with numerical values and not with SmartNames.

b) **Values from file**

If you selected **Values from file** and the input file contains distortion values, you will see these in the fields below (greyed out)



**Note:** The values should be within the 85%-115% range. If the input file's distortion values are outside of this range, the task will end in error.

c) **No distortion**

This is the default option and no distortion will be selected.

You can also use a SmartName that resolves to `Flexo`, `File` or `Not`.

## PDF Objects

Use the **PDF Objects** settings to define:

- how to color manage RGB objects in your input file,
- what dot gain compensation to apply to your input file's images.

All parameters in this tab are public parameters, that you can fill in when submitting files through Shuttle.

1. In **Default RGB Profile**, specify the profile to use if no profile is specified for a certain RGB object in the input file. The default is `srgb.icc`.

You can use a SmartName that resolves to the full profile name.

2. Select what output profile you want to use when converting RGB objects to CMYK:

- If you want to use the output profile from the input file (if there is one available), leave **Use output intent from file** selected (it is selected by default).
- If you don't want to use the output profile from the input file, deselect **Use output intent from file** and specify the output profile to use in **Output Color Profile**.

This output profile will also be used if there is none available in the input file.

The default is `ISOcoated_v2_300_eci.icc`.

For the **Use output intent from file** option, you can use a SmartName that resolves to `true` (to use the file's profile) or `false` (to not use it).

For **Output Color Profile**, you can use a SmartName that resolves to the full profile name.

3. Select **Use PDF transfer curves** if you want to use:



- the *Dot Gain Compensation curves* attached to the images in your input PDF. These curves compensate for the unwanted characteristics of the device that created the images (scanner, digital camera...).
- the **Color Correction curves** added by ArtPro+ version 20 and higher. These curves allow you to correct individual separations for color deviations on proof from the reference proof. The correction will be applied on both the proof and the production files.

**Note:**

You can only use the correction curves if the Color Correction curves option is enabled in the global Imaging Engine configuration.

Please contact Esko Support for assistance.

You can use a SmartName that resolves to `true` (to use the input file's curves) or `false` (to not use them).

4. If you experience issues with a font that doesn't look smooth enough at your selected resolution, your font may have **font hinting errors**.

Font hinting is the rendering of the outline (vectorized) font to pixels. For certain fonts, this rendering sometimes doesn't give a visually pleasing result, especially at low resolutions. In the image below, the top font has font hinting errors, the bottom font doesn't.

Label Pack  
Label Pack

Choose how to handle files containing font hinting errors:

- Leave **Task ends in error when the job contains font hinting errors** selected if you want the task to end in error when encountering font hinting errors. You can also use a SmartName resolving to `true`.
- Deselect **Task ends in error when the job contains font hinting errors** if you want to output your file anyway, whether it has font hinting errors or not (your task will end with a warning). You can also use a SmartName resolving to `false`.

This may lead to reduced quality rendering of the text, but it will not generate incorrect characters in your output file.

5. If your PDF+ input file has linked artwork and the external reference files have been modified, the changes do not get updated automatically in the PDF+ file. This will result in outdated data in the input as well as output files.

Choose how to handle files containing **outdated linked artwork**:

- Select **Task ends in error when linked artwork is not up to date** if you want the task to end in error if the input file contains outdated external references. You can also use a SmartName resolving to `true`.
- Deselect **Task ends in error when linked artwork is not up to date** if you want to output the file anyway, whether the references are outdated or not (your task will end with a warning). You can also use a SmartName resolving to `false`. This is the default option.

## Processing Steps

### What is a Processing Step?

PDF input files typically contain different types of objects, used at different stages of the production process: not only printable objects (that make up the design), but also other objects containing **post-processing data** (for example a cut path or crease lines).

Your production workflow needs to handle these object types accordingly.

If your customers, suppliers, etc. all define their post-processing data in their own way (for example a die cut path could be in a separation called "die" or "cut"), it can lead to:

- needing to make the production workflow more complex to catch all possibilities,
- loss of time,
- mistakes (possibly wasting plates or having a wrong print).

Imaging Engine and Pack Proof support the [ISO 19593 standard](#), that defines "**processing steps**" corresponding to different types of post-processing data. With input files that use these processing steps, you can work in a more uniform way, increasing efficiency and decreasing mistakes.

### Processing Step Groups

The **ISO 19593 standard** groups the different processing steps as follows:

#### Structural Data

Contours indicating how the printed product will be processed to make a 3D end product.

These include for example cutting, creasing and folding lines, and correspond to operations performed by finishing devices like die cutters, folder-glueers, etc.

#### Braille

Contours of objects representing braille content. The braille characters are made after printing, typically by a die cutter or inkjet device.

#### Legend

PDF objects outside the boundaries of the actual printed product (for example solid patches of the inks used in the design). They can contain job related data used in review, approval, and manual production steps.

#### Dimensions

These are also outside the printed area, and indicate the physical size of certain items in the design (using arrows, numbers and units).

#### Positions

Contours giving the position of certain graphic elements (for example where a barcode should be, or which area of a folding carton flap can be printed). They can also be used to indicate areas where graphic elements shouldn't be printed.

**White**

PDF objects indicating where the white backing ink (the opaque white ink used for white underprint on transparent or metallic substrates) will be on the design.

**Varnish**

PDF objects indicating where the varnish will go after printing.

Imaging Engine and Pack Proof also include the following custom processing steps groups by default:

**Esko\_PlateCutting**

Contours indicating how a flexo plate needs to be cut.

**Esko\_PlateID**

PDF objects containing information to identify the plate.



**Note:**

See [Structural Data Processing Steps](#) on page 1405 and [Positions Processing Steps](#) on page 1406 for a more detailed list of the processing steps in these groups.

The **Esko\_PlateID** is only used in the **Image to Screened Separations** task. See [Plate ID Processing Step](#) on page 1340.

**Structural Data Processing Steps**

Structural data processing steps are contours indicating how the printed product will be processed to make a 3D end product.

These include for example cutting, creasing and folding lines, and correspond to operations performed by finishing devices like die cutters, folder-glueers, etc.

This processing step type:	indicates:
Cutting	where the printed artwork will be cut from the printed sheet (for example with a guillotine cutter or die cutting device)
PartialCutting	where the substrate will be cut partially (not entirely through the material)
ReversePartialCutting	where the substrate will be cut partially (not entirely through the material) on the back side of the substrate
Creasing	where the substrate will be creased to guide subsequent folding
ReverseCreasing	where the substrate will be creased on the back side of the substrate
CuttingCreasing	where the substrate will undergo alternating cutting and creasing
ReverseCuttingCreasing	where the substrate will undergo alternating cutting and creasing on the back side of the substrate
PartialCuttingCreasing	where the substrate will undergo alternating partial cutting and creasing

This processing step type:	indicates:
ReversePartial-CuttingCreasing	where the substrate will undergo alternating partial cutting and creasing on the back side of the substrate
Drilling	locations where the substrate will be drilled, and the intended size of the resulting hole
Gluing	an area where glue will be applied
FoilStamping	an area where foil will be applied through hot foil stamping
ColdFoilStamping	an area where foil will be applied through cold foil stamping (using glue)
Embossing	an area where embossing will be applied
Debossing	an area where debossing will be applied
Perforating	where the substrate will be perforated
Bleed	the intended bleed for print
VarnishFree	an area where it is not allowed to have varnish
InkFree	an area where it is not allowed to have printing ink
InkVarnishFree	an area where it is not allowed to have printing ink or varnish
Folding	where the substrate will be folded without prior creasing
Punching	where the substrate will be punched, and the size and shape of the resulting holes
Stapling	where the substrate will be stapled or stitched, and the size of the staples or stitches to be used

**Positions Processing Steps**

Positions processing steps are contours giving the position of certain graphic elements (for example where a barcode should be, or which area of a folding carton flap can be printed). They can also be used to indicate areas where graphic elements shouldn't be printed.

This processing step type:	indicates:
Hologram	the intended position of holograms
Barcode	the intended position of barcodes
ContentArea	areas where it is allowed to place text and other graphical elements
CodingMarking	<p>areas where additional information (not contained in the PDF) will be printed on the packaging at a post-press stage (such as on filling lines where the final products are being packed).</p> <p>These processing step objects are specific to packaging and can be used for lot numbers, production dates, best before dates, tracking codes...</p>
Imprinting	areas where additional information will be printed in a secondary print stage (after most of the graphical content is already printed).

This processing step type:	indicates:
	This can be used to indicate the position of variable data for example.

## Working with Processing Steps

### The Processing Steps tab

Imaging Engine and Pack Proof display the processing steps associated with the layers in your input file (or files placed in it) in the **Processing Steps** tab.

The list of processing steps that you see depends on various factors like the number of jobs you select, the input file type, etc.

If you select input files that are not PDF files	the <b>Processing Steps</b> tab will not be visible as processing steps are only applicable to PDF files  For example, for Normalized PDF files, the <b>Processing Steps</b> tab will always be hidden.
If you select only one job	only the processing steps of your job's printable layers are listed in the <b>Processing Steps</b> tab
If you select multiple jobs or if you don't select any job	all the processing steps supported by Imaging Engine and Pack Proof are listed
If your input file contains no layers	the processing steps tab will display an empty table with the "No printable processing steps found" message
If your input file contains layers that do not have equivalent processing steps in Imaging Engine/ Pack Proof	those layers will not be listed under this tab



**Note:** Adobe Illustrator layers can also be used as processing steps though they are not the same as PDF layers.

### Handling Processing Steps Content

By default, all processing steps are selected. This means that the processing steps data will be treated as regular content and go through the RIP. If an ink is only used by a processing step and that processing step is selected, Imaging Engine will output a separation for that ink.

If you don't want to output some processing step data (for example a cut line), deselect that processing step. You can also select or deselect a group: for example, deselect **Structural** to deselect all processing steps from that group.

Inks only used by deselected or non-printable processing steps will not be displayed in the **Inks** or **Separations** tabs and no separation will be generated for these inks.

### Custom Processing Steps

You can add custom processing steps manually in the **Processing Steps** tab: use the **Add** button at the bottom of the tab (or the **Remove** button to remove a custom processing step).

This useful if you want to use the same ticket with different selected/deselected processing steps for different files.



**Note:** You cannot add the same custom processing step twice.

## Inks

Use the **Inks** settings to select which separations of the input file(s) you want to RIP.

For example, you can use these settings to exclude technical and/or varnish inks from your output.

You can choose to RIP either:

- **All** separations.
- A number of separations you select **Manually**.
- A number of separations you select **by using selection criteria**.

Selection criteria are rules that you define to select separations automatically for you when the task is launched on a file.

Selecting separations manually is the easiest option, but you can only do it on a file by file basis (when you launch the task on a single input file).

Using selection criteria is more advanced but also more powerful than selecting separations manually, and you can do it anytime (when launching the task on one or more input files, when using the task in a workflow, when defining ticket settings...).

Therefore, we recommend that you first try selecting separations manually when running the task on individual files, then switch to using selection criteria to automate your workflow further.



**Tip:**

To get used to working with selection criteria, try the following on a few of your files:

1. select the separations you want to output manually,
2. then change **Select Inks** to **by using selection criteria** and see which rules have been created based on your manual selection.

For more information, see [Selecting Inks Manually](#) on page 1408 and [Selecting Inks Using Selection Criteria](#) on page 1409.



**Tip:** You can also make the ink selection parameter public so that an operator can set it [through Shuttle](#) as needed for each job. See [Selecting Inks through Shuttle](#) on page 1413 for more information.



## Selecting Inks Manually



**Note:** You can only select inks manually when you are launching the task on a (single) file, not when you are defining a generic ticket without an input file.

When choosing to **Select Inks Manually**, you will see a table containing all of your document's inks, showing each ink's:

Ink Name	

<p><b>Ink Book</b></p>	<p>If an ink book is not present in your color database, it will show here as &lt;unregistered ""&gt;.</p>
<p><b>Ink Index</b></p>	<p>The <b>Ink index</b> is the order in which the file's inks will be printed (the ink with ink index 1 is at the bottom of the document and will be printed first).</p> <p>If your file has several of the same ink, they will have the same ink index, and the next ink will have the next one (for example two Cyans will both have ink index 1, then Magenta will have ink index 2).</p> <p>This means that when selecting inks for processing, both Cyans will be selected together and handled the same way.</p> <div data-bbox="523 629 1425 1061" style="border: 1px solid #ccc; padding: 10px; background-color: #f9f9f9;"> <p> <b>Tip:</b></p> <p>To find the ink index of a file:</p> <ol style="list-style-type: none"> <li>1. select the file in the Automation Engine Pilot's <b>Files</b> view,</li> <li>2. click ,</li> <li>3. in the <b>Info</b> dialog that opens, select <b>Inks</b> in the left panel.</li> </ol> <p>The order of the inks at right is the ink index (the topmost ink has an index of 1, the second of 2, etc.)</p> <p>Note that if you reorder the inks by one of the columns (for example by <b>Ink name</b>), they won't be ordered by ink index anymore. You will need to close that dialog and reopen it to see the ink index order again.</p> </div>
<p><b>Spot Ink Index</b></p>	<p>The <b>Spot Ink index</b> is the order in which a spot ink will be printed (when counting only spot inks and not process inks).</p> <p>For example, if the first 4 inks of the document are CMYK, the first spot ink will have 5 as <b>Ink Index</b> but 1 as <b>Spot Ink Index</b>.</p> <p>As for the ink index, if your file has several of the same spot ink, they will have the same spot ink index, and will be handled together when you select them.</p>
<p><b>Ink Type</b></p>	<p>This can be for example <i>Normal, Technical, Varnish...</i></p>
<p><b>Printing Method</b></p>	<p>If you have set a <b>Printing Method</b> for an ink it will be shown here (this can be for example <i>Offset, Gravure, Flexo...</i> or any custom printing method you configured).</p> <p>See the Automation Engine documentation for more information about printing methods.</p>

Select the ink(s) you want to RIP, or select the toggle in the table header to select/deselect all inks.

### Selecting Inks Using Selection Criteria

If you don't want to [select inks manually](#) every time, you can define some rules to automatically select certain inks in your input file(s).

You can do this:

- either when running the task on one or more files, or when creating a task ticket to use later,
- by choosing to **Select Inks by using selection criteria** in the **Document Inks** settings.

**How Does it Work?**

You select the inks to be output by checking a combination of criteria:

1. You define what to check. You can check any of the following ink characteristics in your criteria:

<b>Ink name</b>	
<b>Ink book</b>	
<b>Ink index</b>	<p>The <b>Ink index</b> is the order in which the file's inks will be printed (the ink with ink index 1 is at the bottom of the document and will be printed first).</p> <p>To find the ink index of a file:</p> <ol style="list-style-type: none"> <li>1. select the file in the Automation Engine Pilot's <b>Files</b> view,</li> <li>2. click ,</li> <li>3. in the <b>Info</b> dialog that opens, select <b>Inks</b> in the left panel.</li> </ol> <p>The order of the inks at right is the ink index (the topmost ink has an index of 1, the second of 2, etc.).</p> <p>Note that if you reorder the inks by one of the columns (for example by <b>Ink name</b>), they won't be ordered by ink index anymore. You will need to close that dialog and reopen it to see the ink index order again.</p>
<b>Spot ink index</b>	<p>The <b>Spot ink index</b> is the order in which a spot ink will be printed (when counting only spot inks and not process inks).</p> <p>For example, if the first 4 inks of the document are CMYK, the first spot ink will have 5 as <b>Ink index</b> but 1 as <b>Spot ink index</b>.</p>
<b>Ink type</b>	This can be for example Normal, Technical, Varnish...
<b>Printing method</b>	<p>If you have set a <b>Printing method</b> for an ink it will be shown here (this can be for example <i>Offset, Gravure, Flexo...</i> or any custom printing method you configured).</p> <p>See the Automation Engine documentation for more information about printing methods.</p>

For example, you can check whether the **Ink book is** process, whether the **Ink name is** yellow...

You can use as many criteria as you want.

2. You define how to combine your criteria into a rule. For example:

- If you want to output only process yellow, you should check for inks that match **both** of the criteria:

**Ink book is** process  
**Ink name is** yellow

- If you want to output both all process inks and all yellow inks, you should check for inks that match **either** of the criteria:

**Ink book is** process  
**Ink name is** yellow



- If you don't want to output any process inks or any yellow inks, you should check for inks that match **neither** of the criteria:

**Ink book is** process

**Ink name is** yellow

### How Do I Build Rules?

Build your rules the following way:

**1.** Choose how to combine the criteria in your rule:

- Select **All of the following are true** if you want to only select the inks that match **all** of the criteria you define.
- Select **Any of the following are true** if you want to select all the inks that match **at least one** of the criteria you define.
- Select **None of the following are true** if you want to only select the inks that match **none** of the criteria you define.

**2.** Define your first selection criterion.

You can select an ink based on its:

- **Ink name:** you can define if it **contains/begins with/ends with/is** a piece of text (alphanumerical characters), or if it **is empty**.
- **Ink book:** you can define if it **contains/begins with/ends with/is** a piece of text (alphanumerical characters), or if it **is empty**.
- **Ink index:** you can define if it **equals/is less than/is greater than** the number you enter, or **is between** the two numbers you enter (in this case the ink indexes you enter as boundaries are also selected).
- **Spot ink index:** you can define if it **equals/is less than/is greater than** the number you enter, or **is between** the two numbers you enter (in this case the spot ink indexes you enter as boundaries are also selected).
- **Ink type:** you can define if it **is** a piece of text (alphanumerical characters).
- **Printing method:** you can define if it **is** a piece of text (alphanumerical characters).

For example, you could use:	to:
<b>All of the following are true</b> <b>Ink book is</b> designer	select all inks from the "designer" ink book
<b>None of the following are true</b> <b>Ink name is</b> crease	exclude an ink called "crease"
<b>None of the following are true</b> <b>Ink type is</b> Technical <b>Ink type is</b> Varnish	exclude all technical and all varnish inks



**Tip:**

- You can enter several values to check for: just use a semicolon (;) between them.  
For example, to check for both inks called Cyan and inks called Magenta, choose **Ink name is** and enter Cyan;Magenta.
- When launching the task on a file, you can also click  to select one or more of the **Ink names/Ink books/Ink types/Printing methods** used in your input file(s).  
A criterion will automatically be created based on your selection.

3. Click + to add more criteria and define them.

To remove a criterion, click - next to it.



**Tip:** If you are launching the task on a single input file, you will see a table listing the **Selected document inks**, and another table with the **Document inks that are not selected** under the rules you defined.



**Attention:** If no ink is selected, you cannot launch the task.

### Switching How You Select Inks

You can switch between the two methods of selecting inks (*manually* and *using selection criteria*), and this will keep the same inks selected.

#### Switching from Selecting Inks Manually to Selecting Inks Using Selection Criteria

When switching from selecting inks manually to selecting inks using selection criteria, the task will translate your manual ink selection into rules, so that the same inks are selected (you can see them in the **Selected document inks** table).

The rules you get are based on the characteristics of the inks you selected.

For example, if you selected all the process colors but no spot color in your file, for an offset job, you will get the following rule:

**All of the following are true**

**Ink name is** Cyan;Magenta;Yellow;Black

**Ink book is** process

**Ink type is** Normal

**Printing method is** Offset



**Note:**

If you...

- first selected inks using selection criteria,
- then switched to manual selection without changing the selection,
- then switched back to selection criteria,

... then your rules will be kept.

If you did change the selection in manual mode, the task will automatically generate new rules.

### Switching from Selecting Inks Using Selection Criteria to Selecting Inks Manually

When switching from selecting inks using selection criteria to selecting inks manually, all the inks selected by the rules you defined (the inks in the **Selected document inks** table) become selected manually.



**Note:** You can only switch to selecting inks manually when you are launching the task on a (single) file.

### Selecting Inks through Shuttle

If you want to be able to decide which inks to RIP when submitting your input file *through Shuttle*, do the following:

#### In Your Imaging Engine Ticket

- To make the ink selection a public parameter, you can either:
  - Right-click **Select Inks** and choose **Make Parameter Public**.
  - If you (are currently launching the ticket on a file and) have chosen to *select inks manually*, right-click the preview table under **Select Inks** and choose **Make Parameter Public**.

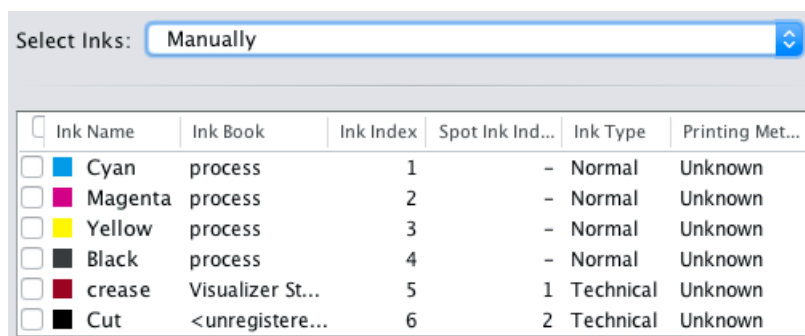

- If you have chosen to *use selection criteria*, right-click the rules builder under **Select Inks** and choose **Make Parameter Public**.

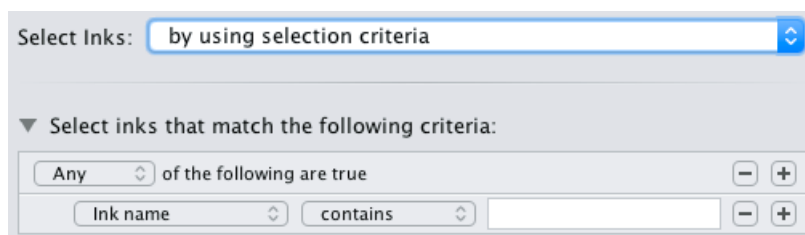

**Note:** You will not be able to create rules using Shuttle, you will only be able to select inks manually.

- Go to **Advanced > Manage Public Parameters...**, find the **Ink Selection** parameter at the bottom of the list, and drag it to the right hand side.

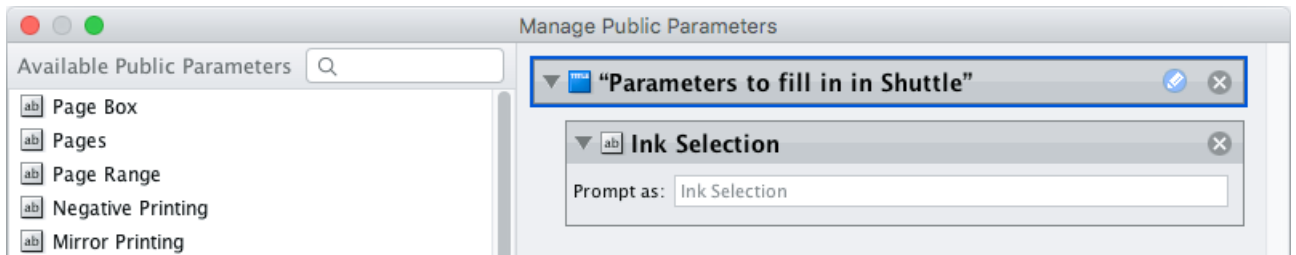

2. By default, the public parameter that appears in Shuttle will be called **Ink Selection**. You can change its name by:
  - right-clicking one of the elements mentioned above, selecting **Modify Public Parameter** and entering a new name,
  - if you are using the **Manage Public Parameters** window, entering the new name in **Prompt as**.
3. Make sure your ticket is also **Public**.

### In Shuttle

The ink selection parameter may look a bit different depending on which Shuttle you are using (the Shuttle standalone application or a Shuttle plug-in in an Editor application).

- In the Shuttle standalone, the ink selection parameter will look like this:

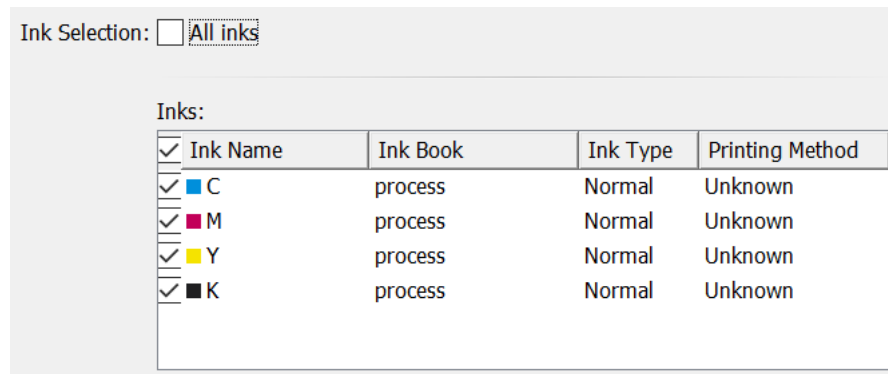

The table shows a preview of all inks in your input file, with their characteristics.

- To RIP all inks from your input file, either leave all inks selected in the preview table, or select **All inks** at the top (this will hide the preview table).
- To only RIP certain inks, make sure **All inks** is not selected, and deselect the input inks that you don't want to RIP.
- In ArtPro+ for example, the ink selection parameter will look like this:

Ink Selection:

Ink Name:	<input type="text" value="Cyan"/>	<input type="button" value="-"/>	<input type="button" value="+"/>
Ink Name:	<input type="text" value="Magenta"/>	<input type="button" value="-"/>	<input type="button" value="+"/>
Ink Name:	<input type="text" value="Yellow"/>	<input type="button" value="-"/>	<input type="button" value="+"/>
Ink Name:	<input type="text" value="Black"/>	<input type="button" value="-"/>	<input type="button" value="+"/>

By default, all the inks from your input file will be RIP'ed, but you can remove any ink you don't want to RIP using the  button.

## File Output

Use the **File Output** settings to define what type of output you want and where to output it.

You can set these through public parameters or using SmartNames.

1. Enter your output **File Name** and output **Folder**.



**Note:**

- You can use Imaging Engine-specific SmartNames for the **File Name**.  
For example, you can add the [Printing Unit] SmartName if you have added printing unit information in ArtPro+ . This way, the printing unit number will be included in the file name, making it easier for the press operator to know on which printing tower of the press each separation should be printed.  
By default, the **File Name** is set to:
  - [File]\_[ShortInk] for single page input files (which gives output file names like Myfile\_C.tif),
  - [File]\_p[Page]\_[ShortInk] for multi-page input files (which gives output file names like Myfile\_p1\_C.tif).
- The **File Name** and **Folder** can contain special characters (except \ / : \* ? < > " |).
- The whole path to the output file (including the container, **Folder** and **File Name**) can be up to 255 characters.
- You can set a local or remote URL for the output **Folder**, but it must be an absolute path.
- If your output folder doesn't exist yet, the task will create it if the location you request is valid (you should place this folder on an Automation Engine container accessible by your Automation Engine user).  
If the output folder creation fails, please check the task log for the full list of conditions and adapt your output folder path accordingly.

2. Define what to do if a file of the same name already exists in your output folder:

a) Click **Set Overwrite Policy...**

b) Choose what to do **If files exist already**. You can either:

- **Extend the file name** if you want to keep the existing output file and give the new output file a different name. In this case, your new output file name consists of:
  - the **Output file name** (the **File Name** you set earlier) - which is what the file would be called if no file with the same name existed,
  - a custom suffix that you can define using plain text and/or SmartNames (by default, this is \_c, for "copy"),
  - an automatic suffix made of the three last digits of the task **ID**,



**Tip:**

To see the task ID of your tasks:

1. Go to the Pilot's **Tasks** pane (in the **Files** or **Tasks** view).
2. Go to **View > Select Columns in 'Tasks'...**
3. In the **Columns** dialog, select **Task ID** in the **Available columns** list and click  to move it to the **Show these columns:** list.
4. Click **OK**.
5. You now have a **Task ID** column in the **Tasks** pane, listing the task ID of all the tasks.

- the file extension.

For example, you are working with a CMYK input file called `file.pdf` and you have left the tasks' output **File Name** to its default value (the SmartName **[File]**).

The first TIFF files you generate will be called:

- `file_C.tif`
- `file_M.tif`
- `file_Y.tif`
- `file_K.tif`

If you generate output from this input file again, with the task 3669, and you have set the overwrite policy to **Extend the file name** with the default **Output File Name + \_c + ID** name, the new output files will be called:

- `file_C_c669.tif`
- `file_M_c669.tif`
- `file_Y_c669.tif`
- `file_K_c669.tif`



**Tip:**

- If you are working with the Bitmap Viewer, we recommend you keep the default overwrite policy (**Output File Name + \_c + ID**), which is compatible with the Bitmap Viewer.
- If you are not, you can define the custom suffix as you wish. For example, you could use date and time SmartNames.

- **Overwrite** the existing file(s).
- **End the task in error.**



**Note:** If you use a SmartName to set this, it must resolve to `extend` or 0 (for **Extend the file name**), `overwrite` or 1 (for **Overwrite**), or `error` or 2 (for **End the task in error**).

c) Click **Set**.

3. Select the output **File Type** you want. This can be a **TIFF File** or a **PDF File**.

See [File Formats](#) on page 1224 for more information.

4. For both TIFF and PDF, you can choose to output either *composite* or *separated* files.

- To output **Composite** files, select **1 File Per Page** in **File Assembly** (or use a SmartName that resolves to `FilePerPage`).

The **Output Type** is then automatically set to **Composite**.

- To output **Separated** files, select **1 File Per Separation** in **File Assembly** (or use a SmartName that resolves to `FilePerSeparation`).

The **Output Type** is then automatically set to **Separate**.



**Note:**

- Every output file that Imaging Engine generates contains XMP metadata (information about file creation, separations, calibration curves, etc.).

You can view this XMP metadata by selecting your output file in the Automation Engine Pilot's **Files** view and clicking [i](#).

For more information about XMP metadata, see the **XMP Metadata white paper** under **Related Documentation** on the [documentation page of your Imaging Engine version](#).

- TIFF files produced by Imaging Engine are fully compatible with Esko's Bitmap Viewer and DotSpy.
- Separated files are shown in the correct separation in the Bitmap Viewer (as it can read the separation information in the XMP data) and in grayscale in other viewers.

When proofing them, they are also in the correct separation (for example the proofer proofs the Magenta file using the Magenta cartridge).

5. Choose the **Compression** to use for your output files.

- For **TIFF** output, you can choose between lossless and lossy compression. Lossless compression preserves all the detail in the file, while lossy compression removes some detail.

We recommend you use lossless compression for the final output (for files you will send to a third party RIP for example), and lossy compression only for previews and thumbnails.

For both compression types (lossless and lossy), you should then choose a compression method, based on the compression speed and the compressed file size. Typically, faster compression methods compress the file less, so the output file is bigger (note that TIFF files can be a maximum of 4GB).

If you want lossless compression...	choose either: <ul style="list-style-type: none"> <li><b>PackBits</b>, a fast lossless compression method for graphic files.</li> </ul>
-------------------------------------	-----------------------------------------------------------------------------------------------------------------------------------------



	<div data-bbox="703 248 762 309" data-label="Image"> </div> <div data-bbox="783 248 1430 331" data-label="Text"> <p><b>Tip:</b> Use this if you want fast output and file size is not too much of an issue.</p> </div> <ul data-bbox="659 367 1430 432" style="list-style-type: none"> <li>• <b>LZW</b>, a lossless compression method for graphic files and other files.</li> </ul> <div data-bbox="703 459 762 519" data-label="Image"> </div> <div data-bbox="783 459 1430 542" data-label="Text"> <p><b>Tip:</b> This compression method works best for files with large images.</p> </div>
<p>If you want lossy compression...</p>	<p>choose one of the <b>JPEG</b> compression methods (those are more suitable for images like photographs and natural artwork than sharp edged or flat color images like line art or lettering, as JPEG compression tends to introduce noise into solid color areas).</p> <p>They are sorted from very high compression, which reduces the file size a lot but loses a lot of detail (<b>JPEG Limited Quality</b>), to very low compression, which doesn't lose much detail but doesn't reduce the file size much (<b>JPEG Extreme Quality</b>).</p>

- For **PDF** output, all available compression methods are lossless.

You should choose a compression method based on the compression speed and the compressed file size. Typically, faster compression methods compress the file less, so the output file is bigger (note that PDF files can be a maximum of 12GB).

Choose either:

- **PackBits** (see above).
- **Flate**, a lossless compression method similar to zipping, based on the LZW compression.



**Tip:** This compression method works best for images with large single color areas or repeating patterns.

- **JPEG 2000**, a compression method based on **JPEG** and suitable for large images (the version of **JPEG 2000** used by Imaging Engine is lossless).



**Attention:**

- When using a SmartName to set the output file's **Compression**, it must resolve to one of the following (case insensitive):
  - **PackBits, LZW, JPEGLimited, JPEGLow, JPEGStandardLow, JPEGStandard, JPEGStandardHigh, JPEGHigh, or JPEGExtreme** for **TIFF** output,
  - **PackBits, Flate** or **JPEG2000** for **PDF** output.

Setting any other value, or an unsupported compression for the file type you chose, will make the task error (with the message **Unsupported combination of output type and compression** in the log).

- If you have already set the **Compression** but decide to change the output **File Type**, by default the task will either:
  - keep the same **Compression** (if it is supported for the new output **File Type**),
  - or (if it isn't), set it to the first **Compression** available for this **File Type**.

You can still change it as desired.

**6. Select **Make all output files ready for viewing** if:**

- you are generating separated TIFF files,
- you are doing quality control using the **Automation Engine Viewer**,
- you want to be able to open your output files in the **Automation Engine Viewer** without needing to use a **Prepare for Viewer** task.

If you don't use this option, you can still use a **Prepare for Viewer** task later to be able to view your output files in the **Automation Engine Viewer**. However, this will take more time than already preparing the files for viewing in your Imaging Engine task.

As with the **Prepare for Viewer** task, you will see **View (Prepared)** next to the prepared files in the Pilot, and you will be able to zoom in to the files up to their full resolution.



**Note:**

- If you are generating separated PDF files, you can view them in the **Automation Engine Viewer** without preparation.
- You can also view separated TIFF files in the **Bitmap Viewer** without preparation.
- If you use the **Make all output files ready for viewing** option together with composite output files (via SmartNames or Public Parameters), the task will error out.

**7. If you are working with Gravure, Imaging Engine can help you optimize the processing time of your engraving machine by indicating the empty spaces in your output separations, so that your engraving machine can skip them.**



**Note:** This is only possible when working with separated output files (when you have set **File Assembly** to **1 File Per Separation**).

You can do this the following way:

- a) Select **Write skip areas to file** (or use a SmartName resolving to `true`).
- b) In **Threshold**, enter the number of lines that need to be empty before an area is skipped (each line being 1 pixel wide).

You can select any (integer) number that is at least 1, but we recommend you use a large enough number so that it makes sense to lift the engraving head for that amount of empty space (the default threshold is **240 empty lines**).

You can also use a SmartName resolving to your desired number of lines.

In the example below, the whole area at the bottom of the Cyan separation can be skipped.



- c) The task outputs a skip area file (`.svs`) per output separation (whether you output to TIFF or PDF), even for separations that have no empty areas (so the engraving machine will know it cannot skip anything in those separations).

Those `.svs` are generated in the same output folder as your output separations. If you are using the task in a workflow, the task has a separate output pin for the `.svs` files.

- d) When sending your output separations to your engraving machine software, make sure you also send the `.svs` files.

## Rendering

Use the **Rendering** settings to define how to handle images that have a different resolution than the output resolution, and set [other rendering options](#) to optimize your output.

1. Set the **Resolution** of your output files.



**Note:**

- The **Resolution** unit is taken from the general Automation Engine Preferences.
- You can enter values from 1 to 25400 ppi (or equivalent in your unit). SmartNames must also resolve to a value in that range.
- Values in another unit than the one from the general Preferences will be recalculated, and values like 300ppi + 500ppm will be calculated correctly.

2. If your input file contains outlines, line art or contourized text, and you notice that they look too thick on print, we recommend you select the **Fine Line Rendering** option.

This will render objects with fine lines, for example Asian characters or barcodes, with a "thin fill".

You can set this option with a SmartName resolving to `true` to use **Fine Line Rendering** or `false` to use the standard rendering (also known as "fat fill").



**Note:**

If you have an older saved ticket (created in a version of Imaging Engine older than 22.11) with the outdated **Compensate for Outline Thickness** option selected, **Fine Line Rendering** will be used instead.

You will see a message about this:

- when opening the ticket,
- in the task details,
- in the log file.

When using this ticket, the task will end with a warning.

You can choose to not show this message again (in this case it won't be mentioned in the ticket, task details or log file, and the task won't end with a warning), but please note that this will apply to all users of that ticket.

3. If you experience problems with jagged edges, for example in small text, you can set an **Anti-aliasing** factor to smooth those edges.

See [Anti-Aliasing](#) on page 1188 for more information.

You can adjust the amount of anti-aliasing applied by choosing a factor of either 2, 3 or 4 (note that using a higher anti-aliasing factor may slow down processing).

You can also set this with a SmartName resolving to `None` (if you don't need anti-aliasing), or to the anti-aliasing factor you want (for example 2).



**Attention:** Because anti-aliasing changes the output sampling to smooth the jagged edges, you cannot resample your images (with the **Image Resampling** option) if you use anti-aliasing.

4. If needed, you can [resample](#) your images.

This is typically needed when the images' pixels don't map exactly to output pixels, for example if:

- the images' resolution is different from your chosen [output resolution](#),

- scaling and rotation effects change the size and placement of the images' pixels.

In the **Image Resampling** option, choose the resampling method you want to use:

- Choose **Auto Resampling** to upsample the images to an automatically calculated resolution (generally half or a third of the output resolution) before smoothing them.

When using this, images are a lot less pixellated and fuzzy.

This method takes some time but gives images of a good quality, so it is recommended in most cases.

You can also use a SmartName resolving to `ResampleAuto`.

- Choose **Full Resampling** to upsample the images to the full output resolution.

This method is the slowest, but gives the highest quality images (not pixellated and only slightly fuzzy).

You can also use a SmartName resolving to `ResampleFull`.

Use this if **Auto Resampling** doesn't give you the results you want.



**Attention:**

Resampling to full resolution can require significant amounts of memory when the output resolution is high (especially from 4000 dpi).

If you want to do this, we recommend that you have at least 8GB of RAM available for each worker (see the installation documentation).

- Choose **None** if you don't want to resample your input file's images.



**Note:**

If you upgraded from a previous version of Imaging Engine, in some cases you may have saved a ticket with a less optimal resampling method (**From File** or **PDF Interpolation**) in your older version. These methods are deprecated from Imaging Engine 18.1.1.

When processing a file with such a ticket, Imaging Engine will use the **Auto Resampling** method instead. You will get a warning about this.

5. If your input file is a Step and Repeat file, choose whether you want **Identical One-Ups**.

This makes sure that on print, the details look the same in all your one-ups (see [Identical One-Ups](#) on page 1190 for more information).

- Select **On** if you want all one-ups of your input Step and Repeat files to look identical on print.



**Note:**

You can do this for the following input file types:

- *Plato* files (.pdfpla files or Normalized PDFs from Plato),
- Step and Repeat files in the Native PDF format (made by ArtPro+ or 3rd party software),
- Step and Repeat files in the ArtPro Classic file format (.ap or .art), if they were previously Normalized.



**Tip:**

If you were previously using FlexRip in combination with Plato, and setting the **Reset for each external file** option for **Screen Registration** in Plato, select **On** here to get a comparable result with Imaging Engine.

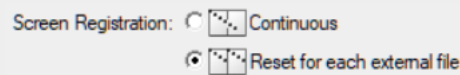

- Select **Off** if:
  - it is not important for you to have identical one-ups when doing Step and Repeat,
  - you are not currently working with Step and Repeat files or files with repeated placed art,
  - if you are re-running a separation from an old job, and want your screens to match the previous run,
  - you were satisfied with the screened output of previous versions of Imaging Engine that did not have this option (22.07 and older).

**Off** is selected by default. We recommend you leave it like this if you don't need identical one-ups, as rendering the one-ups identically can in some cases slow down your output.

- Select **Use from file** to use the information in your input Step and Repeat files to decide whether your one-ups need to be identical or not.

This is only applicable to Plato files with the **Screen Registration** parameter filled in.

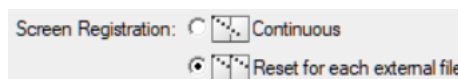

- If your input Plato file has the **Reset for each external file** option selected for the **Screen Registration** parameter, your one-ups will be aligned to the pixel grid to be made identical.
- If your input Plato file has the **Continuous** option selected for the **Screen Registration** parameter, your one-ups will be left as they are.

### Separations

Use the **Separations** settings to define the *dot gain compensation* to apply to the separations that will be output (the separations you selected in the *Inks tab*).

You can:

- apply general curves to all output separations,
  - apply specific curves to certain separations.
1. If desired, you can apply a **Plate Curve** to all output separations.

A plate curve is used to compensate for the dot growth or dot reduction (for example in Digital Flexo) happening when making the plate. You can choose either:

- **None** if you don't want to apply any plate curve.
- **Single Curve** if you want to apply one curve for all separations.

In this case, select the `.dgc` curve to apply at right. You can choose from a list of curves available in the curves database.

- **Curve Strategy** if you want to apply a curve strategy (a file created in Curve Pilot that contains several curves to apply in different cases: it can have different curves per separation, dot shape, ruling, for continuous tone images or line work...).

In this case, select the `.icpro` curve strategy or legacy `.scredgc` screen-based DGC file to apply at right.

You can choose from a list of curve strategies available in the curves database.

For more information, see:

- [Dot Gain Compensation Curves](#) on page 1220,
- [DGC Curve Strategies](#) on page 1221,
- [The Curves Database](#) on page 1224.



**Note:**

- You can use SmartNames resolving to the exact name of the **Single Curve** or **Curve Strategy** (including the extension).
- This will set the **Plate Curve** type to `Unknown` in the ticket, but will resolve to the correct curve type if the SmartNames are correct.

2. If desired, apply a **Press Curve** to all output separations.

This curve is used to compensate for the dot gain on press. You can choose either:

- **None** if you don't want to apply any press curve,
- **Single Curve** if you want to apply one curve for all separations (you can still define exceptions for some of the separations later).

In this case, select the `.dgc` curve to apply at right. You can choose from a list of curves available in the curves database.

- **Curve Strategy** if you want to apply a curve strategy (a file created in Curve Pilot that contains several curves to apply in different cases: it can have different curves per separation, dot shape, ruling, for continuous tone images or line work...).

In this case, select the curve strategy to apply at right (you can select a `.icpro` curve strategy, a `.prsync` PressSync curve set or a legacy `.scredgc` screen-based DGC file).

You can choose from a list of curve strategies available in the curves database.

- **PressSync** if you want to apply a PressSync curve (a predefined curve applicable to your printing environment).

In this case, select the letter and number of the PressSync curve.

For more information, see:

- [Dot Gain Compensation Curves](#) on page 1220,
- [DGC Curve Strategies](#) on page 1221,
- [PressSync Curves](#) on page 1222,
- [PressSync Curve Sets](#) on page 1223,
- [The Curves Database](#) on page 1224.



**Note:**

- You can use SmartNames resolving to the exact name of the **Single Curve, Curve Strategy** (including the extension) or **PressSync** curve.
- This will set the **Press Curve** type to `Unknown` in the ticket, but will resolve to the correct curve type if the SmartNames are correct.

3. If desired, you can also apply a specific press curve to a specific separation (when launching the task on a single file).

To do this, click that separation's **Press Curve** in the table and select the curve you want to use instead.

Your separation-specific curve is shown in italics.

If you want to go back to the previous curve, right-click the curve you just set and select **Clear Custom Value**.

4. If you notice a specific problem in your job, and you want to compensate for it without changing your main curves, you can apply some corrections (to all separations).

See [Corrections](#) on page 1427.

5. If you are setting up a task ticket to use in a workflow for example, you can create a rule to always apply a specific press curve to a specific separation.

You can do this if for example you have a curve you want to use for Yellow in all your jobs, or to use specific curves for specific spot colors...

See [Exceptions](#) to know how to create rules.





**Tip:**

Applying a specific press curve to a specific separation manually (in the table) also automatically creates a rule. So if you are not used to working with rules yet, you can:

1. Take a file containing the separations you usually work with, and open the task on it.
2. In the **Separations** table, set your desired press curves on your separations manually.
3. The task automatically creates the corresponding rules in the **Exceptions** tab (if you change your press curves again, these rules will be updated).
4. Save your ticket. You can now use it on other files that need the same press curves for those separations.

**Corrections**

If you notice a specific dot gain related problem in your job, you can use the **Corrections** settings to compensate for that problem without changing your [general dot gain compensation settings](#) (that you may also use for other jobs).

You can:

- apply a correction curve,
- correct dot gain problems in the highlights,
- correct dot gain problems in the shadows.



**Note:**

The corrections you define here are applied to all output separations. If you need to apply a different correction to a specific separation, we recommend you create a **curve strategy** in Curve Pilot for this purpose.

When doing this, the tools in Curve Pilot help you keep your gray balance in check when changing the dot gain compensation for specific separations.

Please see the [Curve Pilot documentation](#) for more information.

1. If needed, select a **Correction Curve** to apply to all the separations that will be output.

You can select any single curve (.dgc) available in your [curves database](#). You can also use SmartNames resolving to the exact .dgc file name (including the extension).

2. Choose when to **Apply the Correction Curve**:

- **Before Press Curve**
- **Between Press & Plate Curve**
- **After Plate Curve**
- you can also use a SmartName resolving to `BeforePress`, `BetweenPressAndPlate` or `AfterPlate`.

The order in which you apply your dot gain compensation curves makes a difference to your final result. In the example below, you can see what happens to the 50% value depending on the order of the curves:

- When applying the correction curve first (**Before Press Curve**):
  1. The **Correction Curve** changes the initial 50% value to 60%.

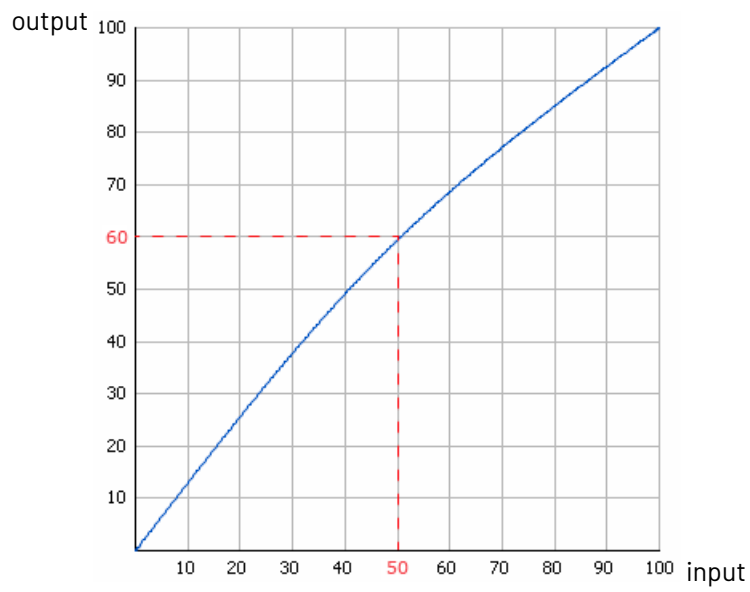

2. For that 60% value, the **Press Curve** gives 48%.

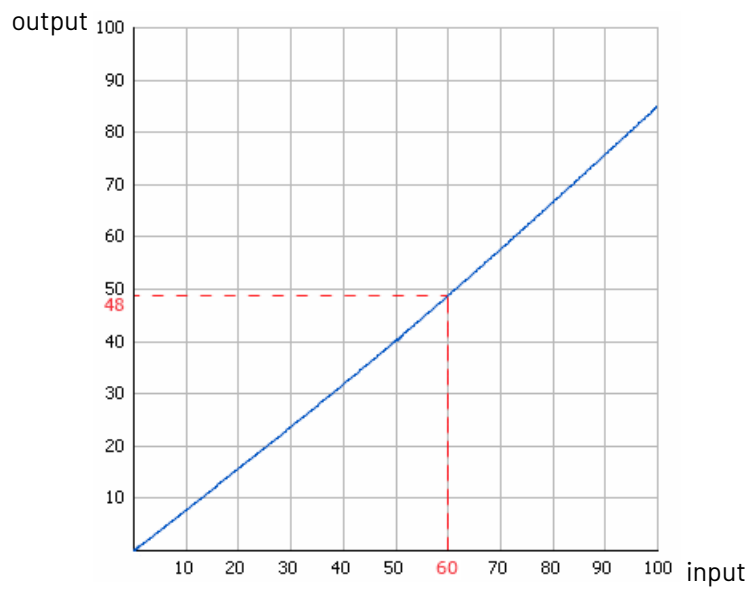

3. For that 48% value, the **Plate Curve** gives a final value of **53%**.

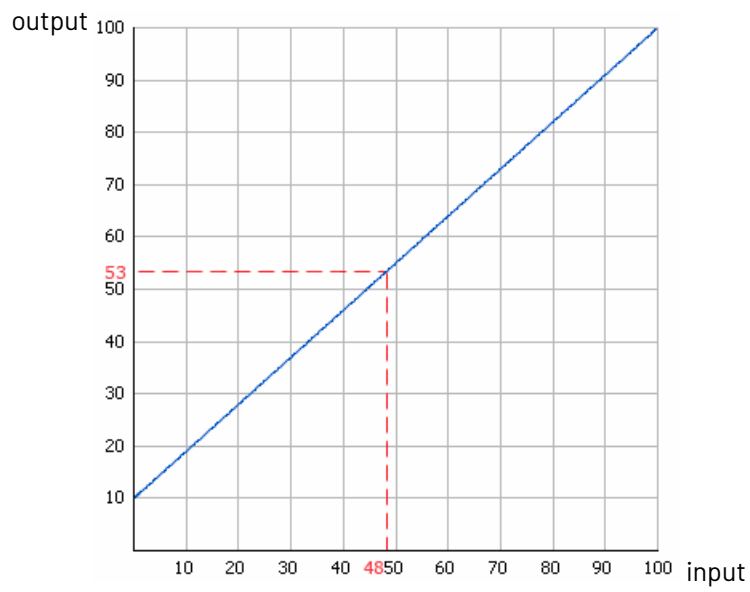

- When applying the correction curve **Between Press & Plate Curve**:

1. The **Press Curve** changes the initial 50% value to 40%.

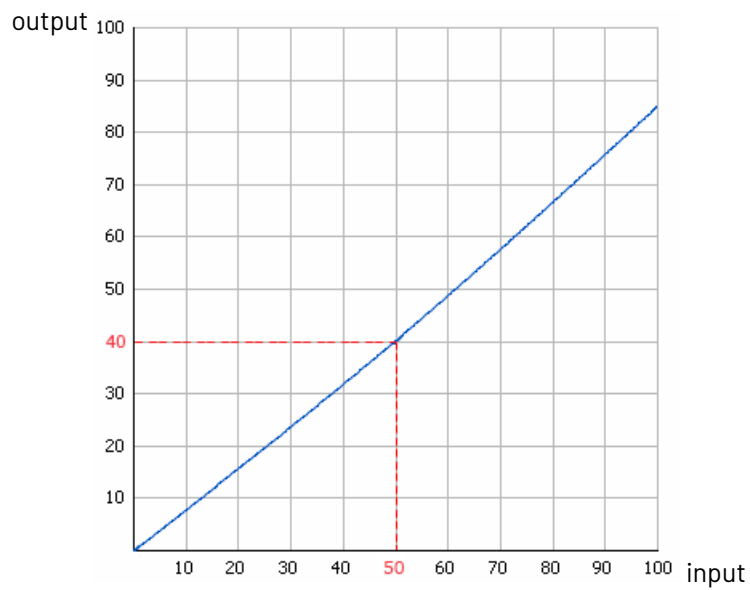

2. For that 40% value, the **Correction Curve** gives 49%.

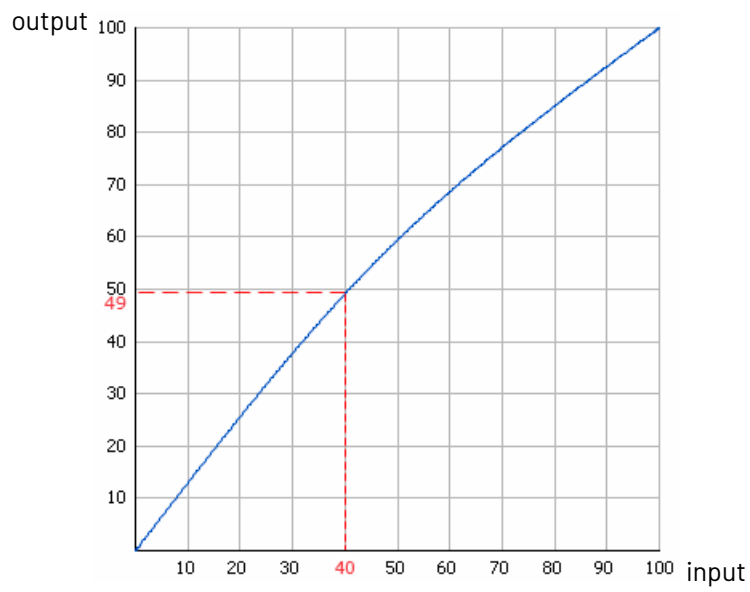

3. For that 49% value, the **Plate Curve** gives a final value of **54%**.

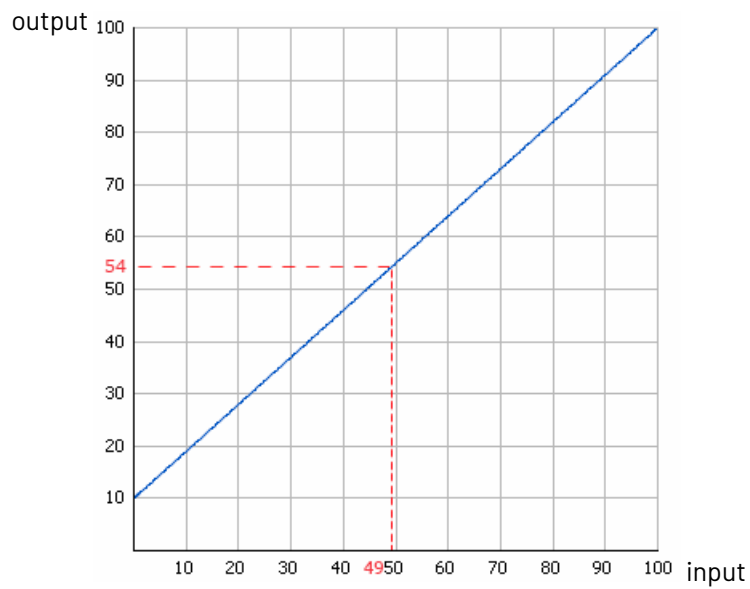

- When applying the correction curve last (**After Plate Curve**):
  1. The **Press Curve** changes the initial 50% value to 40%.

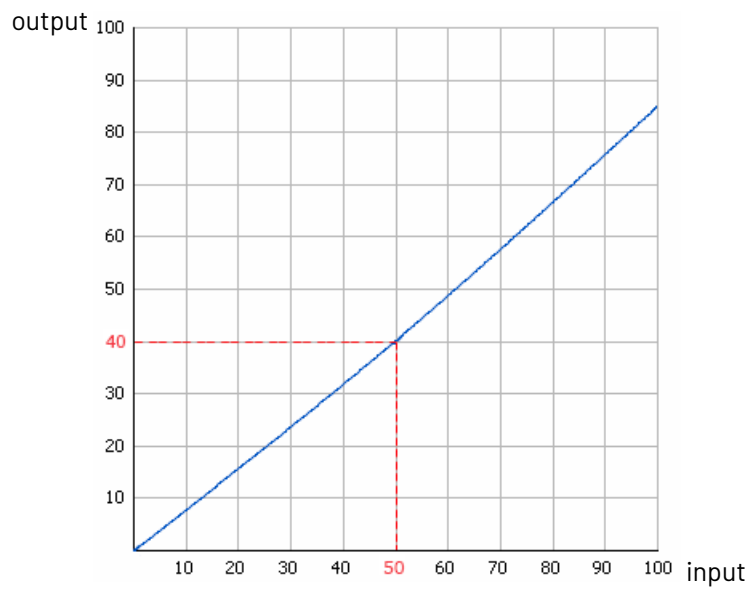

2. For that 40% value, the **Plate Curve** gives 46%.

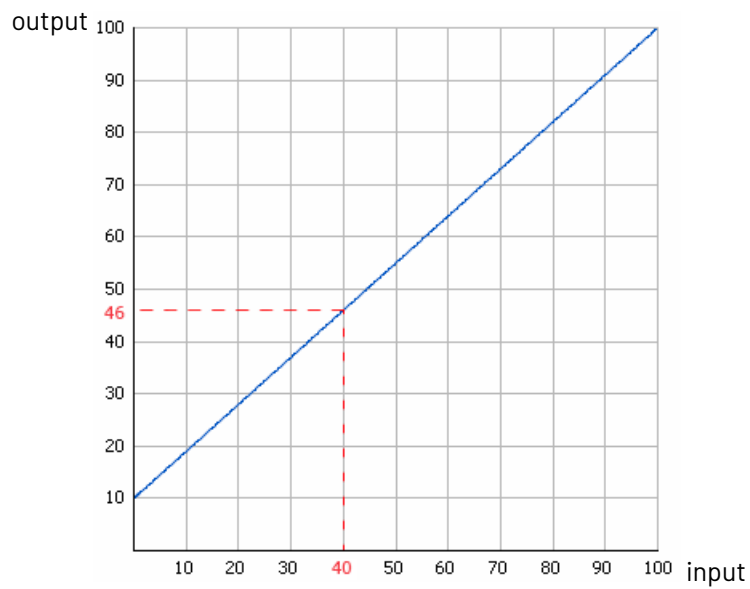

3. For that 46% value, the **Correction Curve** gives a final value of **56%**.

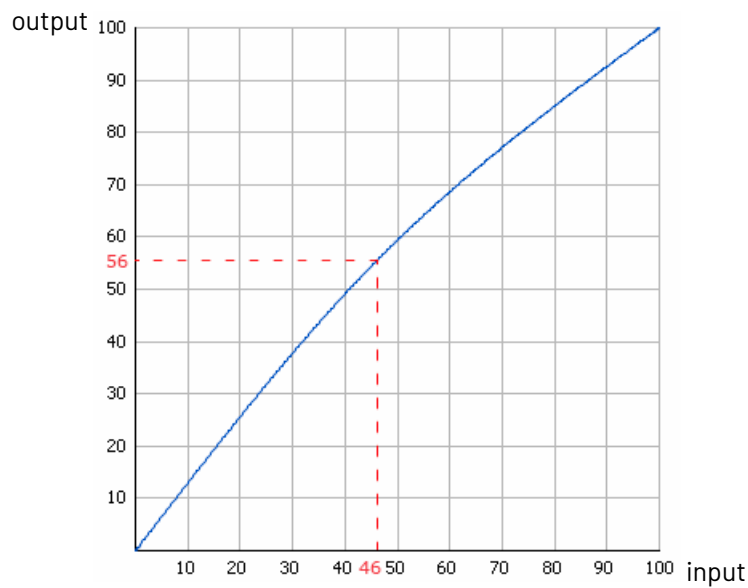

3. After your curves have been applied, you can also use the **Range Correction** to correct dot gain problems in the highlights and/or shadows.
  - Select **Minimum Correction** if you only want to correct the highlights.
  - Select **Maximum Correction** if you only want to correct the shadows.
  - Select **Minimum & Maximum Correction** if you want to correct both highlights and shadows.
  - You can also use a SmartName resolving to `Minimum`, `Maximum` or `MinimumAndMaximum`.



**Note:**

- If you have already applied a highlights and/or shadows correction in your *plate curve* or *press curve* you don't need to make that correction again here.
- Correcting your highlights and/or shadows does not affect your mid-tones. If you want to correct your mid-tones, you can use a **correction curve**.

4. If you have problems with the highlights (for example if they are grainy or print unevenly), you can do the following to correct them:
  - a) In **Minimum Dot**, enter the smallest percentage that you know won't give you any printing problem. In the unscreened files, Imaging Engine will not generate percentages any smaller than what you enter here.



**Note:**

- The **Minimum Dot** must be within the 0%-30% range. If you enter a percentage outside of this range it will be automatically adjusted to the nearest value in the range (for example 32 will be adjusted to 30%).
- When using a SmartName, it must resolve to a number between 0 and 30 (without the % sign). If you use a SmartName that resolves to a percentage outside the range, the task will end in error.
- You can enter a simple formula and it will be calculated automatically (for example you can enter 10+2 and this will be changed to 12%). This only works with numerical values and not with SmartNames.

b) In **How to Handle Minimum Job Tones**, enter the range of input file tones that typically gives you problems on output (for example, you may find that tones between 0% and 1% in your input file give you grainy images on output).



**Note:**

- The **Minimum Job Tones** range always starts at 0% and can go up to 10%. If you enter a percentage outside of this range it will be automatically adjusted to the nearest value in the range.
- When using a SmartName, it must resolve to a number between 0 and 10 (without the % sign). If you use a SmartName that resolves to a percentage outside the range, the task will end in error.
- You can enter a simple formula and it will be calculated automatically. This only works with numerical values and not with SmartNames.

c) Decide how to treat this range of problematic tones to prevent output problems. You can either:

- Not print those small percentages (select **Drop To 0%**).

In this case, anything in that range will be rendered at 0% (so removed from the output), and the first percentage above that will become the **Minimum Dot**.

In the example below, the **Minimum Job Tones** are 0% to 5% and the **Minimum Dot** is 10%.

If you select **Drop To 0%**, the 0% to 5% range in your input file becomes 0% in the output, and the first percentage after that (5.01%) becomes 10% (the **Minimum Dot**).

Higher percentages follow the dot gain compensation you applied (the combination of the plate curve, press curve and correction curve you have set). Note that the transition between your highlights correction and the combined curve is smoothed to give you better printing results.

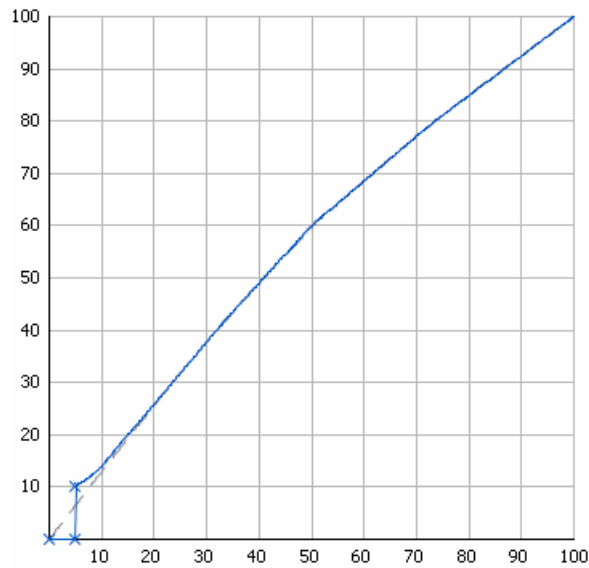

- Increase those small percentages so they meet the threshold to become your **Minimum Dot** on output (select **Hold To Minimum Dot**).

In this case, anything in that range (except 0%) will be rendered at the percentage you entered as **Minimum Dot**.

With the same example, if you select **Hold To Minimum Dot**, 0% will stay 0%, and the 0.01% to 5% range in your input file will become 10% in the output (the **Minimum Dot**).

Higher percentages follow the dot gain compensation you applied (the combination of the plate curve, press curve and correction curve you have set). Note that the transition between your highlights correction and the combined curve is smoothed to give you better printing results.

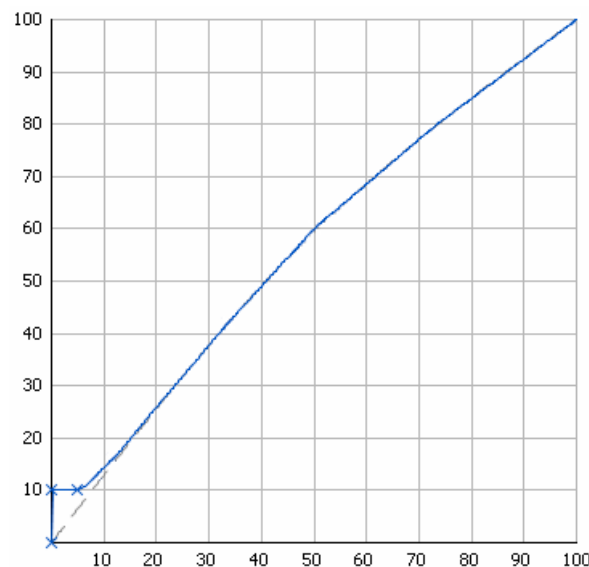



5. If you have problems with the shadows (for example you lose detail in the darkest areas), you can do the following to correct them:

- a) In **Maximum Dot**, enter the highest percentage that you know you can safely print for a good result in the shadows. In the unscreened files, Imaging Engine will not generate percentages any higher than what you enter here.



**Note:**

- The **Maximum Dot** must be within the 70%-100% range. If you enter a percentage outside of this range it will be automatically adjusted to the nearest value in the range (for example 68 will be adjusted to 70%).
- When using a SmartName, it must resolve to a number between 70 and 100 (without the % sign). If you use a SmartName that resolves to a percentage outside the range, the task will end in error.
- You can enter a simple formula and it will be calculated automatically (for example you can enter 70+5 and this will be changed to 75%). This only works with numerical values and not with SmartNames.

- b) In **How to Handle Maximum Job Tones**, enter the range of input file tones that typically gives you problems on output (for example, you may find that tones between 97% and 100% don't show enough details on output).



**Note:**

- The **Maximum Job Tones** range can start from 90% and always go up to 100%. If you enter a percentage outside of this range it will be automatically adjusted to the nearest value in the range.
- When using a SmartName, it must resolve to a number between 90 and 100 (without the % sign). If you use a SmartName that resolves to a percentage outside the range, the task will end in error.
- You can enter a simple formula and it will be calculated automatically. This only works with numerical values and not with SmartNames.

- c) Decide how to treat this range of problematic tones to prevent output problems. You can either:

- Make those large percentages solid (select **Raise To 100%**).

In this case, anything in that range will be rendered at 100%, and the first percentage below that range will become the **Maximum Dot**.

In the example below, the **Maximum Job Tones** are 95% to 100% and the **Maximum Dot** is 90%.

If you select **Raise To 100%**, the 95% to 100% range in your input file becomes 100% in the output, and the first percentage below that (94.99%) becomes 90% (the **Maximum Dot**).

Lower percentages follow the dot gain compensation you applied (the combination of the plate curve, press curve and correction curve you have set). Note that the transition between the combined curve and your shadows correction is smoothed to give you better printing results.

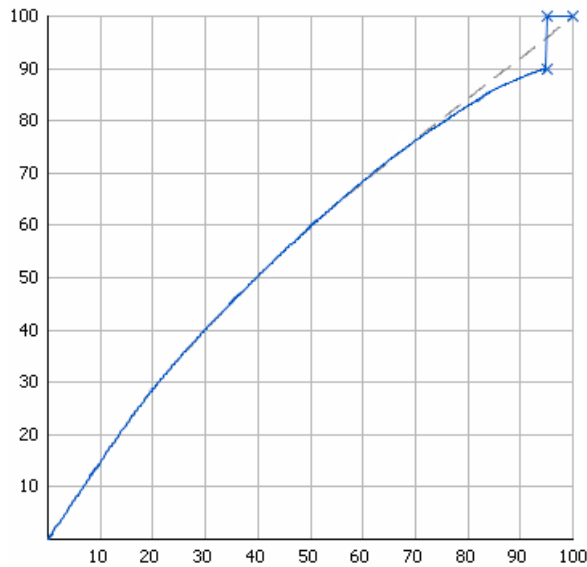

- Decrease those large percentages so they become your **Maximum Dot** on output (select **Hold To Maximum Dot**).

In this case, anything in that range (including 100%) will be rendered at the percentage you entered as **Maximum Dot**.

With the same example, if you select **Hold To Maximum Dot**, the 95% to 100% range in your input file will become 90% in the output (the **Maximum Dot**).

Lower percentages follow the dot gain compensation you applied (the combination of the plate curve, press curve and correction curve you have set). Note that the transition between the combined curve and your shadows correction is smoothed to give you better printing results.

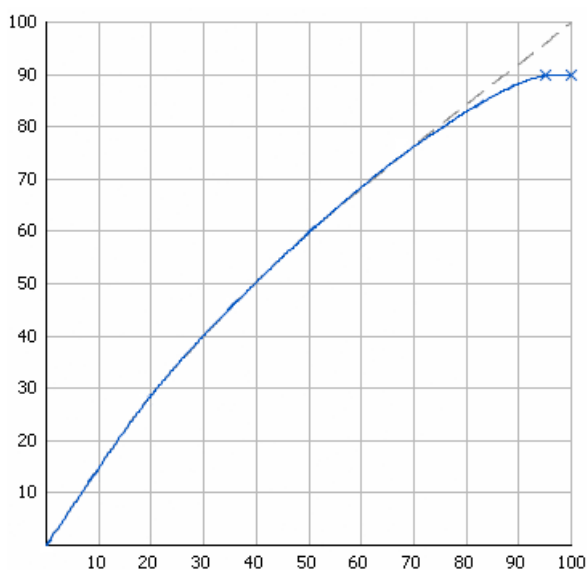

6. You can see the number of corrections you applied next to the **Corrections** tab at left.  
 For example, if you apply a **Correction Curve**, a **Minimum Correction** (on the highlights), and a **Maximum Correction** (on the shadows), you will see **Corrections (3)**.

**Exceptions**

Use the **Exceptions** tab if you want to always apply specific press curves to certain separations (for example spot colors).

The press curves you select in this tab will overrule your general *press curve* for those separations.

You can do this anytime (when launching the task on one or more input files, when defining ticket settings, when setting up a workflow...).

You do this by setting up **rules**. This works as follows:

- You create a rule for each separation or set of separations that need a specific press curve.
- Within each rule:
  1. You select the separation(s) you want to apply a specific curve to. You do this by setting criteria that a separation has to match to be selected.

For example if you want to select all process inks, you can set that the ink book must be `process` for the inks to be selected.

You can use the following ink characteristics in your criteria:

<b>Ink name</b>	
<b>Ink book</b>	
<b>Ink index</b>	<p>The <b>Ink index</b> is the order in which the file's inks will be printed (the ink with ink index 1 is at the bottom of the document and will be printed first).</p> <p>To find the ink index of a file:</p> <ol style="list-style-type: none"> <li>1. select the file in the Automation Engine Pilot's <b>Files</b> view,</li> <li>2. click ,</li> <li>3. in the <b>Info</b> dialog that opens, select <b>Inks</b> in the left panel.</li> </ol> <p>The order of the inks at right is the ink index (the topmost ink has an index of 1, the second of 2, etc.).</p> <p>Note that if you reorder the inks by one of the columns (for example by <b>Ink name</b>), they won't be ordered by ink index anymore. You will need to close that dialog and reopen it to see the ink index order again.</p>
<b>Spot ink index</b>	<p>The <b>Spot ink index</b> is the order in which a spot ink will be printed (when counting only spot inks and not process inks).</p> <p>For example, if the first 4 inks of the document are CMYK, the first spot ink will have 5 as <b>Ink index</b> but 1 as <b>Spot ink index</b>.</p>
<b>Ink type</b>	This can be for example <code>Normal</code> , <code>Technical</code> , <code>Varnish...</code>

<b>Printing method</b>	<p>If you have set a <b>Printing method</b> for an ink it will be shown here (this can be for example <i>Offset, Gravure, Flexo...</i> or any custom printing method you configured).</p> <p>See the Automation Engine documentation for more information about printing methods.</p>
------------------------	---------------------------------------------------------------------------------------------------------------------------------------------------------------------------------------------------------------------------------------------------------------------------------------

2. You choose the press curve to apply to the selected separation(s).

- If you have several rules, you can reorder them in order of priority (the top one is applied first).

In practice, you need to do the following in the **Exceptions** tab:

1. Click **+** at the bottom of the table.
2. In the **Rules Properties** dialog, enter a **Rule Name**.
3. Under **If separation matches**, define one or more criteria to select your desired separation(s).

You can use the following elements:

- **Ink name:** you can define if it **contains/begins with/ends with/is** a piece of text (alphanumerical characters), or if it **is empty**.
- **Ink book:** you can define if it **contains/begins with/ends with/is** a piece of text (alphanumerical characters), or if it **is empty**.
- **Ink index:** you can define if it **equals/is less than/is greater than** the number you enter, or **is between** the two numbers you enter (in this case the ink indexes you enter as boundaries are also selected).
- **Spot ink index:** you can define if it **equals/is less than/is greater than** the number you enter, or **is between** the two numbers you enter (in this case the spot ink indexes you enter as boundaries are also selected).
- **Ink type:** you can define if it **is** a piece of text (alphanumerical characters).
- **Printing method:** you can define if it **is** a piece of text (alphanumerical characters).



**Tip:**

- You can enter several values to check for: just use a semicolon (;) between them.  
For example, to check for both inks called *Cyan* and inks called *Magenta*, choose **Ink name is** and enter *Cyan;Magenta*.
- Click **+** to add more criteria. You can also add sub-criteria by holding **Alt** while clicking **+**.  
For example, if you want to make a rule for *Process Yellow*, you can use:  
**All of the following are true:**  
**Ink name is** *Yellow*  
**Ink book is** *Process*
- When launching the task on a file, you can also click  to select one or more of the **Ink names/Ink books/Ink types/Printing methods** used in your input file(s).  
A criterion will automatically be created based on your selection.

4. Select **Press Curve** and choose the press curve to use for the selected separation(s).
5. Click **Add**.

You can see your rule and the **Press Curve** that will be applied to your selected separation(s) in the **Exceptions** tab table.



**Tip:** You can double-click your rule if you still want to edit it.



**Note:** If you have defined specific press curves for certain separations *manually* (when launching the task on a single file), you can see that these curves have been automatically added as rules in the **Exceptions** tab (and shown in italics).

6. Repeat steps 1 to 5 to define more rules if desired.

If you want to remove a rule, select it and click **Remove**.

You can see the number of rules defined next to the **Exceptions** tab at left.

7. If desired, you can reorder your rules (they are applied from top to bottom). To do this, select a rule and click **Move Up** or **Move Down** (or drag it up or down).
8. When launching the task on a single file, you can see the file's separations and the press curves that will be applied to them in a table (make sure to leave the **Preview** option selected).

This is the same table as at the bottom of the **Separations** tab. It includes:

- the curves you have *defined for all separations*,
- the curves you have defined *for specific separations*,
- the curves defined by your exception rules.

As in the **Separations** tab, you can use this table to define specific press curves for certain separations.

To do this, click that separation's **Press Curve** in the table and select the curve you want to use instead.

Your separation-specific curve is shown in italics.

If you want to go back to the previous curve, right-click the curve you just set and select **Clear Custom Value**.



**Note:**

When launching your Imaging Engine ticket on a file from Automation Engine Shuttle, you cannot see the exceptions defined in the ticket (Shuttle always displays the parameter values found in the input file).

However, if you modify some public parameter values in Shuttle then launch the ticket, when you go back to the Automation Engine Pilot and open the ticket, you will see all your modified parameters saved as exceptions.

## Summary

This shows a summary of all the settings you defined in the ticket.

- To show the settings from a tab, click + (on PC) or ► (on Mac) beside the tab name in the right pane.

Click **Expand All** to show the settings from all tabs.

- To hide the settings from a tab, click - (on PC) or ▼ (on Mac) beside the tab name in the right pane.

Click **Collapse All** to hide the settings from all tabs.

### 16.5.6. Calculate Ink Key Settings (CIP3)

Use this task to generate *ink distribution data* for the files you want to send to your offset press.

If you send this data to the press along with your press-ready RIP'ed files, the press can automatically calculate the amount of ink needed for each separation of your RIP'ed files, without needing manual adjustments from the press operator.

In the example below, after the prepress is done, your file is both:

- RIP'ed by the *Image to Screened Separations* task to produce your press-ready files, which are then copied to the platesetter queue,
- RIP'ed by the **Calculate Ink Key Settings (CIP3)** task to produce the ink distribution data, which is then sent to the press room.

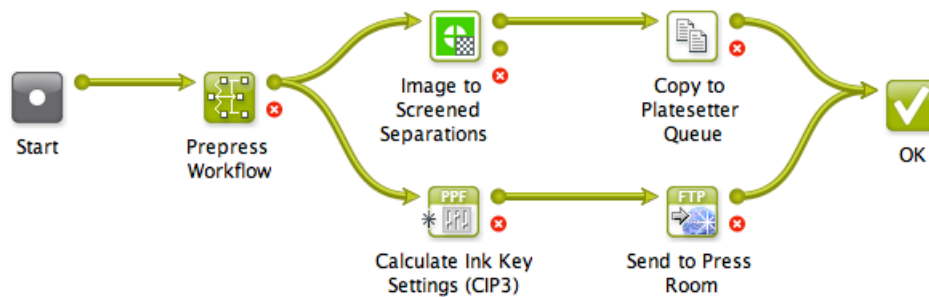

#### Task Output

When sending a file to the **Calculate Ink Key Settings (CIP3)** task, it generates its ink distribution data in the form of one or more (unscreened) CIP3 file(s), in the .ppf format (Print Production Format).

This is a press standard format which can be used with many types of press (for example Heidelberg, Man Roland, Creo, Komori...).

A CIP3 file contains:

- a low resolution version of the part of the input file it corresponds to (you can output a CIP3 file per separation, per page, per side of a two-sided file...),
- the ink distribution for that part of the file (an overview of how much of which separation is used in which area of the file).

For example, for the following single page CMY input file:



... the task can generate a Cyan, a Magenta and a Yellow .ppf file, indicating where the ink needs to be.

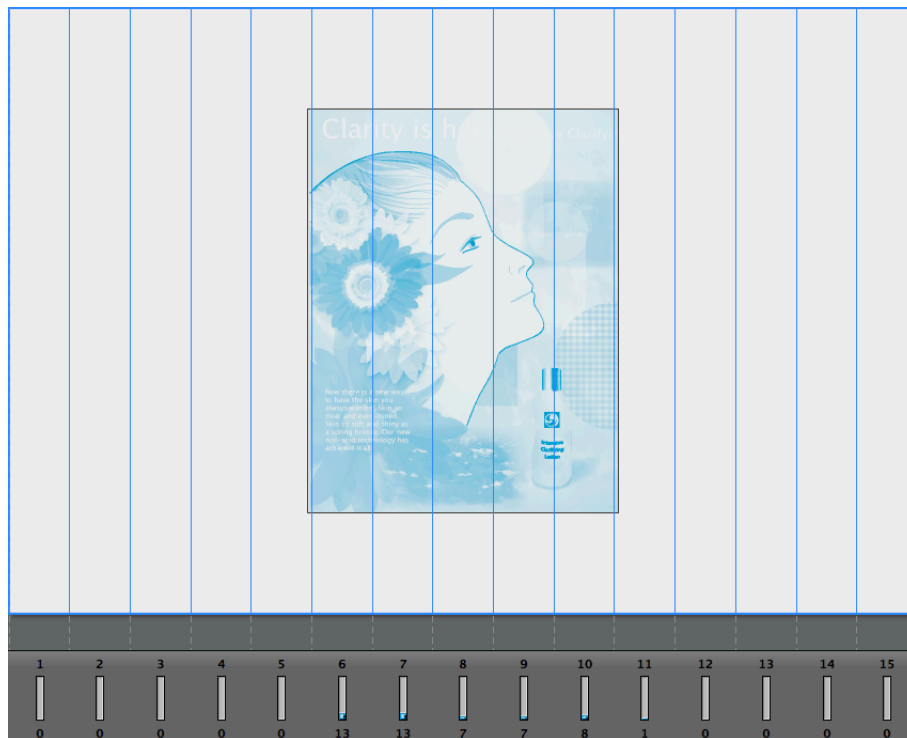

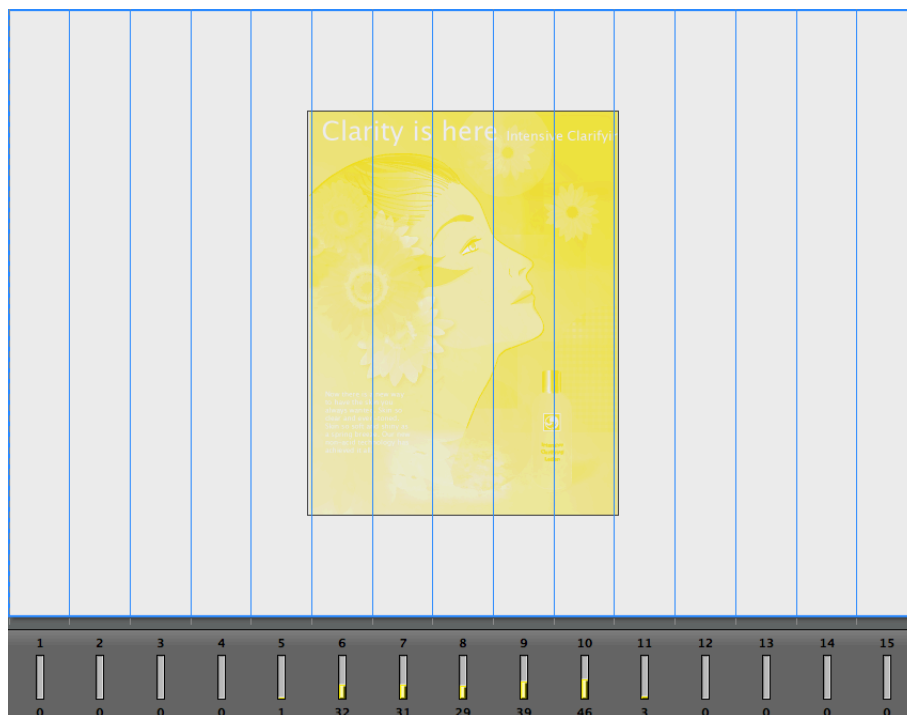
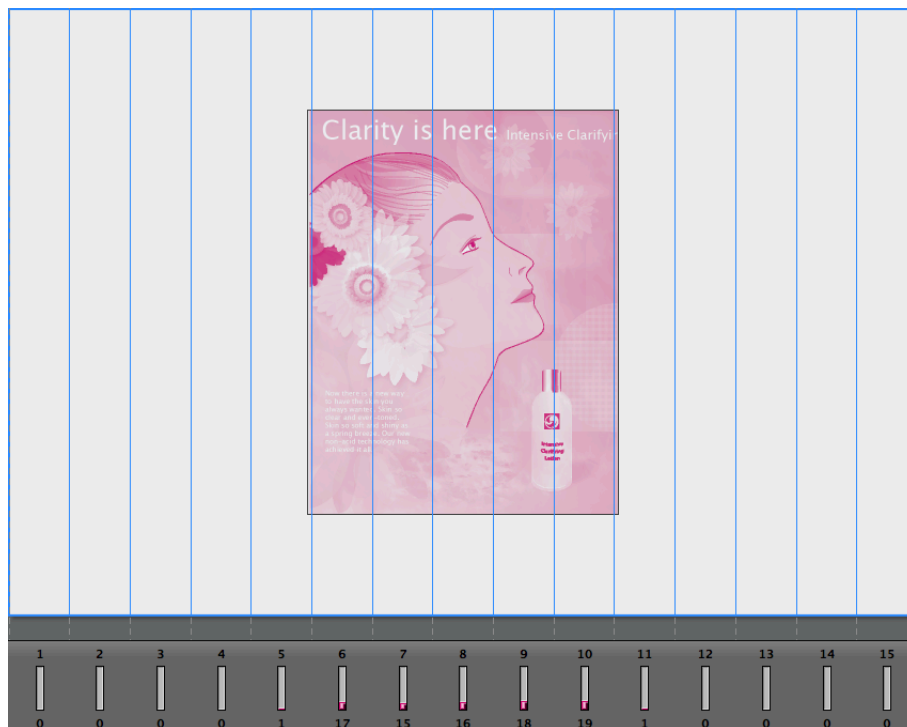

**Task Parameters**

In the **Device** field, select the imaging device *that you configured*.

Then use the tabs at left to show more settings to fill in. See:



- [General](#) on page 1443,
- [Transformations](#) on page 1444,
- [PDF Objects](#) on page 1445,
- [Processing Steps](#) on page 1447
- [Inks](#) on page 1451,
- [Sizes and Offsets](#) on page 1458,
- [Production Data](#) on page 1460,
- [Paper Data](#) on page 1463,
- [File Output](#) on page 1465,
- [Summary](#) on page 1470.

## General

1. Define what **Page Box** of the input PDF you want to RIP.

You can either select **Media Box**, **Trim Box**, or insert a SmartName `[]` that must resolve to either `media` or `trim`.

After selecting your file's page box you will see its dimensions under the **Page Box** option.

2. If your input file is a multi-page PDF, select which **Pages** you want to RIP:

- a) First select **All pages**, **Odd pages only** or **Even pages only** in the **Pages** option.

You can also insert a SmartName resolving to either `All`, `Even` or `Odd`.

- b) Then you can refine your selection by entering page numbers or a **Page Range**.

You can separate page numbers by a comma, or use a dash to indicate a page range (for example `3, 6-9`). You can also use a SmartName resolving to page numbers and/or page ranges using this same format.



### Note:

- Page numbers are always physical pages. If your document starts with page 5, you should not use 5 but 1 to get the first page.
- If you enter page numbers that are not part of your document, they will be excluded from the output (all the other valid pages will be RIP'ed).
- If you enter the same page(s) more than once (for example `1, 1-2`), it/they will only be output once.
- Pages are RIP'ed in the order of the document (entering `5-1` will be automatically changed to `1-5`).

3. If you want to invert your output so it is compatible with the output device or software system that will process it, click **A**.

You can also click `[]` or **Edit...** to insert a SmartName that must resolve to `1` or `true` (to invert the output), or to `0` or `false` (to leave the output as it is).

4. If you want to mirror your output so it is compatible with the output device or software system that will process it, click **M**.

You can also click `[]` or **Edit...** to insert a SmartName that must resolve to `1` or `true` (to mirror the output), or to `0` or `false` (to leave the output as it is).

5. If you want to add **SmartMarks (Classic)** or **Dynamic Marks** in your output file(s), select the **Type of Marks** you want to add and then select the specific **Mark Set** you want to use.

**SmartMarks (Classic)** or **Dynamic Marks** are marks whose content is variable, so you can make them display information about that specific job and use them as a production control. For example, you can include some of the parameters used during RIP'ing in your output file(s) by using SmartMarks (Classic) or Dynamic Marks.

You need to:

- a) First create the SmartMarks (Classic) you want to use in **PackEdge** or **Plato** and the Dynamic Marks in **ArtPro+** (see the PackEdge, Plato and Arpro+ manuals for more details).

You can create either:

- a general SmartMark (Classic) or Dynamic Mark (for example a corner mark or split mark),
- a Text Mark with Smart Text, that will display the information included in your input file,
- an Imaging Engine-specific Text Mark with Smart Text, that will display the parameters that you set in the ticket.

To do this, select **Output Parameter** in the **Smart Text** pop-up in the PackEdge/ArtPro + application. Make sure you use the RIP-related SmartMark attributes from the **Output Parameter** category, and not those from the **Ink/Color** category.

If your PackEdge, Plato or ArtPro+ application is linked to your Automation Engine server, your SmartMarks (Classic) or Dynamic Marks will automatically be saved in the correct location and will be available in Imaging Engine.

- b) Then select that SmartMark (Classic) or Dynamic Mark in your **Imaging Engine task** using the **Mark Set** option.

The SmartMarks (Classic) or Dynamic Marks will be added to each output file generated from your input file.

## Transformations

Use the **Transformations** settings to rotate or distort your output relative to your input file.

1. If you want to rotate your file's contents, select the **Rotation** you want to apply here.

This can be:

- **0°**
- **90° Counter Clockwise**
- **180°**
- **90° Clockwise**

Any other value will give an error.





**Note:**

- You can use a SmartName that resolves to 0, 90 (for **90° Counter Clockwise**), 180 or 270 (for **90° Clockwise**).
- You need to use a numerical value (*ninety* will not work).
- This is a public parameter, that you can fill in when submitting files through Shuttle.

2. If you want to apply **Distortion** to your file's contents, select the type of distortion to apply:

a) **Flexo distortion**

If you want to apply **Flexo distortion**, enter the vertical  and horizontal  distortion percentages to use.

You can enter numerical values, or insert SmartNames that resolve to numerical values (without the % sign).



**Note:**

- The values should be within the 85%-115% range. If you enter a percentage outside of this range it will be automatically adjusted to the nearest value in the range (for example 80 will be adjusted to 85%).  
However, if you use a SmartName that resolves to a percentage outside the range, the task will end in error.
- You can enter a simple formula and it will be calculated automatically (for example you can enter  $100+2$  and this will be changed to 102%). This only works with numerical values and not with SmartNames.

b) **Values from file**

If you selected **Values from file** and the input file contains distortion values, you will see these in the fields below (greyed out)



**Note:** The values should be within the 85%-115% range. If the input file's distortion values are outside of this range, the task will end in error.

c) **No distortion**

This is the default option and no distortion will be selected.

You can also use a SmartName that resolves to `Flexo`, `File` or `Not`.

## PDF Objects

Use the **PDF Objects** settings to define:

- how to color manage RGB objects in your input file,
- what dot gain compensation to apply to your input file's images.

All parameters in this tab are public parameters, that you can fill in when submitting files through Shuttle.

1. Select what output profile you want to use when converting RGB objects to CMYK:

- If you want to use the output profile from the input file (if there is one available), leave **Use output intent from file** selected (it is selected by default).
- If you don't want to use the output profile from the input file, deselect **Use output intent from file** and specify the output profile to use in **Output Color Profile**.

This output profile will also be used if there is none available in the input file.

The default is `ISOcoated_v2_300_eci.icc`.

For the **Use output intent from file** option, you can use a SmartName that resolves to `true` (to use the file's profile) or `false` (to not use it).

For **Output Color Profile**, you can use a SmartName that resolves to the full profile name.

2. In **Default RGB Profile**, specify the profile to use if no profile is specified for a certain RGB object in the input file. The default is `srgb.icc`.

You can use a SmartName that resolves to the full profile name.

3. Select **Use PDF transfer curves** if you want to use:

- the *Dot Gain Compensation curves* attached to the images in your input PDF. These curves compensate for the unwanted characteristics of the device that created the images (scanner, digital camera...).
- the **Color Correction curves** added by ArtPro+ version 20 and higher. These curves allow you to correct individual separations for color deviations on proof from the reference proof. The correction will be applied on both the proof and the production files.



**Note:**

You can only use the correction curves if the Color Correction curves option is enabled in the global Imaging Engine configuration.

Please contact Esko Support for assistance.

You can use a SmartName that resolves to `true` (to use the input file's curves) or `false` (to not use them).

4. If you experience issues with a font that doesn't look smooth enough at your selected resolution, your font may have **font hinting errors**.

Font hinting is the rendering of the outline (vectorized) font to pixels. For certain fonts, this rendering sometimes doesn't give a visually pleasing result, especially at low resolutions. In the image below, the top font has font hinting errors, the bottom font doesn't.

Label Pack

Label Pack

Choose how to handle files containing font hinting errors:

- Leave **Task ends in error when the job contains font hinting errors** selected if you want the task to end in error when encountering font hinting errors. You can also use a SmartName resolving to `true`.
- Deselect **Task ends in error when the job contains font hinting errors** if you want to output your file anyway, whether it has font hinting errors or not (your task will end with a warning). You can also use a SmartName resolving to `false`.

This may lead to reduced quality rendering of the text, but it will not generate incorrect characters in your output file.

5. If your PDF+ input file has linked artwork and the external reference files have been modified, the changes do not get updated automatically in the PDF+ file. This will result in outdated data in the input as well as output files.

Choose how to handle files containing **outdated linked artwork**:

- Select **Task ends in error when linked artwork is not up to date** if you want the task to end in error if the input file contains outdated external references. You can also use a SmartName resolving to `true`.
- Deselect **Task ends in error when linked artwork is not up to date** if you want to output the file anyway, whether the references are outdated or not (your task will end with a warning). You can also use a SmartName resolving to `false`. This is the default option.

## Processing Steps

### What is a Processing Step?

PDF input files typically contain different types of objects, used at different stages of the production process: not only printable objects (that make up the design), but also other objects containing **post-processing data** (for example a cut path or crease lines).

Your production workflow needs to handle these object types accordingly.

If your customers, suppliers, etc. all define their post-processing data in their own way (for example a die cut path could be in a separation called "die" or "cut"), it can lead to:

- needing to make the production workflow more complex to catch all possibilities,
- loss of time,
- mistakes (possibly wasting plates or having a wrong print).

Imaging Engine and Pack Proof support the [ISO 19593 standard](#), that defines "**processing steps**" corresponding to different types of post-processing data. With input files that use these processing steps, you can work in a more uniform way, increasing efficiency and decreasing mistakes.

### Processing Step Groups

The **ISO 19593 standard** groups the different processing steps as follows:

#### Structural Data

Contours indicating how the printed product will be processed to make a 3D end product.

These include for example cutting, creasing and folding lines, and correspond to operations performed by finishing devices like die cutters, folder-glueers, etc.

**Braille**

Contours of objects representing braille content. The braille characters are made after printing, typically by a die cutter or inkjet device.

**Legend**

PDF objects outside the boundaries of the actual printed product (for example solid patches of the inks used in the design). They can contain job related data used in review, approval, and manual production steps.

**Dimensions**

These are also outside the printed area, and indicate the physical size of certain items in the design (using arrows, numbers and units).

**Positions**

Contours giving the position of certain graphic elements (for example where a barcode should be, or which area of a folding carton flap can be printed). They can also be used to indicate areas where graphic elements shouldn't be printed.

**White**

PDF objects indicating where the white backing ink (the opaque white ink used for white underprint on transparent or metallic substrates) will be on the design.

**Varnish**

PDF objects indicating where the varnish will go after printing.

Imaging Engine and Pack Proof also include the following custom processing steps groups by default:

**Esko\_PlateCutting**

Contours indicating how a flexo plate needs to be cut.

**Esko\_PlateID**

PDF objects containing information to identify the plate.



**Note:**

See [Structural Data Processing Steps](#) on page 1448 and [Positions Processing Steps](#) on page 1449 for a more detailed list of the processing steps in these groups.

The **Esko\_PlateID** is only used in the **Image to Screened Separations** task. See [Plate ID Processing Step](#) on page 1340.

**Structural Data Processing Steps**

Structural data processing steps are contours indicating how the printed product will be processed to make a 3D end product.

These include for example cutting, creasing and folding lines, and correspond to operations performed by finishing devices like die cutters, folder-glueers, etc.

This processing step type:	indicates:
Cutting	where the printed artwork will be cut from the printed sheet (for example with a guillotine cutter or die cutting device)

This processing step type:	indicates:
PartialCutting	where the substrate will be cut partially (not entirely through the material)
ReversePartialCutting	where the substrate will be cut partially (not entirely through the material) on the back side of the substrate
Creasing	where the substrate will be creased to guide subsequent folding
ReverseCreasing	where the substrate will be creased on the back side of the substrate
CuttingCreasing	where the substrate will undergo alternating cutting and creasing
ReverseCuttingCreasing	where the substrate will undergo alternating cutting and creasing on the back side of the substrate
PartialCuttingCreasing	where the substrate will undergo alternating partial cutting and creasing
ReversePartial-CuttingCreasing	where the substrate will undergo alternating partial cutting and creasing on the back side of the substrate
Drilling	locations where the substrate will be drilled, and the intended size of the resulting hole
Gluing	an area where glue will be applied
FoilStamping	an area where foil will be applied through hot foil stamping
ColdFoilStamping	an area where foil will be applied through cold foil stamping (using glue)
Embossing	an area where embossing will be applied
Debossing	an area where debossing will be applied
Perforating	where the substrate will be perforated
Bleed	the intended bleed for print
VarnishFree	an area where it is not allowed to have varnish
InkFree	an area where it is not allowed to have printing ink
InkVarnishFree	an area where it is not allowed to have printing ink or varnish
Folding	where the substrate will be folded without prior creasing
Punching	where the substrate will be punched, and the size and shape of the resulting holes
Stapling	where the substrate will be stapled or stitched, and the size of the staples or stitches to be used

### Positions Processing Steps

Positions processing steps are contours giving the position of certain graphic elements (for example where a barcode should be, or which area of a folding carton flap can be printed). They can also be used to indicate areas where graphic elements shouldn't be printed.

This processing step type:	indicates:
Hologram	the intended position of holograms
Barcode	the intended position of barcodes
ContentArea	areas where it is allowed to place text and other graphical elements
CodingMarking	<p>areas where additional information (not contained in the PDF) will be printed on the packaging at a post-press stage (such as on filling lines where the final products are being packed).</p> <p>These processing step objects are specific to packaging and can be used for lot numbers, production dates, best before dates, tracking codes...</p>
Imprinting	<p>areas where additional information will be printed in a secondary print stage (after most of the graphical content is already printed).</p> <p>This can be used to indicate the position of variable data for example.</p>

### Working with Processing Steps

#### The Processing Steps tab

Imaging Engine and Pack Proof display the processing steps associated with the layers in your input file (or files placed in it) in the **Processing Steps** tab.

The list of processing steps that you see depends on various factors like the number of jobs you select, the input file type, etc.

If you select input files that are not PDF files	<p>the <b>Processing Steps</b> tab will not be visible as processing steps are only applicable to PDF files</p> <p>For example, for Normalized PDF files, the <b>Processing Steps</b> tab will always be hidden.</p>
If you select only one job	only the processing steps of your job's printable layers are listed in the <b>Processing Steps</b> tab
If you select multiple jobs or if you don't select any job	all the processing steps supported by Imaging Engine and Pack Proof are listed
If your input file contains no layers	the processing steps tab will display an empty table with the "No printable processing steps found" message
If your input file contains layers that do not have equivalent processing steps in Imaging Engine/ Pack Proof	those layers will not be listed under this tab



**Note:** Adobe Illustrator layers can also be used as processing steps though they are not the same as PDF layers.



## Handling Processing Steps Content

By default, all processing steps are selected. This means that the processing steps data will be treated as regular content and go through the RIP. If an ink is only used by a processing step and that processing step is selected, Imaging Engine will output a separation for that ink.

If you don't want to output some processing step data (for example a cut line), deselect that processing step. You can also select or deselect a group: for example, deselect **Structural** to deselect all processing steps from that group.

Inks only used by deselected or non-printable processing steps will not be displayed in the **Inks** tab, and the task will not generate ink distribution data for these inks.

## Custom Processing Steps

You can add custom processing steps manually in the **Processing Steps** tab: use the **Add** button at the bottom of the tab (or the **Remove** button to remove a custom processing step).

This is useful if you want to use the same ticket with different selected/deselected processing steps for different files.



**Note:** You cannot add the same custom processing step twice.

## Inks

Use the **Inks** settings to select for which separations of your input file(s) you want to generate *ink distribution data*.

For example, you can use these settings to make sure that technical and/or varnish inks are not taken into account.

You can choose to generate ink distribution data for either:

- **All** separations.
- A number of separations you select **Manually**.
- A number of separations you select **by using selection criteria**.

Selection criteria are rules that you define to select separations automatically for you when the task is launched on a file.

Selecting separations manually is the easiest option, but you can only do it on a file by file basis (when you launch the task on a single input file).

Using selection criteria is more advanced but also more powerful than selecting separations manually, and you can do it anytime (when launching the task on one or more input files, when using the task in a workflow, when defining ticket settings...).

Therefore, we recommend that you first try selecting separations manually when running the task on individual files, then switch to using selection criteria to automate your workflow further.



### Tip:

To get used to working with selection criteria, try the following on a few of your files:

1. select the separations you want to output manually,
2. then change **Select Inks** to **by using selection criteria** and see which rules have been created based on your manual selection.

For more information, see [Selecting Inks Manually](#) on page 1452 and [Selecting Inks Using Selection Criteria](#) on page 1453.





**Tip:** You can also make the ink selection parameter public so that an operator can set it *through Shuttle* as needed for each job. See *Selecting Inks through Shuttle* on page 1456 for more information.

### Selecting Inks Manually



**Note:** You can only select inks manually when you are launching the task on a (single) file, not when you are defining a generic ticket without an input file.

When choosing to **Select Inks Manually**, you will see a table containing all of your document's inks, showing each ink's:

<b>Ink Name</b>	
<b>Ink Book</b>	If an ink book is not present in your color database, it will show here as <unregistered "">.
<b>Ink Index</b>	<p>The <b>ink index</b> is the order in which the file's inks will be printed (the ink with ink index 1 is at the bottom of the document and will be printed first).</p> <p>If your file has several of the same ink, they will have the same ink index, and the next ink will have the next one (for example two Cyans will both have ink index 1, then Magenta will have ink index 2).</p> <p>This means that when selecting inks for processing, both Cyans will be selected together and handled the same way.</p> <div style="border: 1px solid #ccc; padding: 5px; margin-top: 10px;">  <p><b>Tip:</b></p> <p>To find the ink index of a file:</p> <ol style="list-style-type: none"> <li>1. select the file in the Automation Engine Pilot's <b>Files</b> view,</li> <li>2. click ,</li> <li>3. in the <b>Info</b> dialog that opens, select <b>Inks</b> in the left panel.</li> </ol> <p>The order of the inks at right is the ink index (the topmost ink has an index of 1, the second of 2, etc.).</p> <p>Note that if you reorder the inks by one of the columns (for example by <b>ink name</b>), they won't be ordered by ink index anymore. You will need to close that dialog and reopen it to see the ink index order again.</p> </div>
<b>Spot Ink Index</b>	<p>The <b>Spot Ink index</b> is the order in which a spot ink will be printed (when counting only spot inks and not process inks).</p> <p>For example, if the first 4 inks of the document are CMYK, the first spot ink will have 5 as <b>Ink Index</b> but 1 as <b>Spot Ink Index</b>.</p> <p>As for the ink index, if your file has several of the same spot ink, they will have the same spot ink index, and will be handled together when you select them.</p>
<b>Ink Type</b>	This can be for example Normal, Technical, Varnish...
<b>Printing Method</b>	If you have set a <b>Printing Method</b> for an ink it will be shown here (this can be for example Offset, Gravure, Flexo... or any custom printing method you configured).

	See the Automation Engine documentation for more information about printing methods.
--	--------------------------------------------------------------------------------------

Select the ink(s) you want to RIP, or select the toggle in the table header to select/deselect all inks.

### Selecting Inks Using Selection Criteria

If you don't want to *select inks manually* every time, you can define some rules to automatically select certain inks in your input file(s).

You can do this:

- either when running the task on one or more files, or when creating a task ticket to use later,
- by choosing to **Select Inks by using selection criteria** in the **Document Inks** settings.

#### How Does it Work?

You select the inks to be output by checking a combination of criteria:

1. You define what to check. You can check any of the following ink characteristics in your criteria:

<b>Ink name</b>	
<b>Ink book</b>	
<b>Ink index</b>	<p>The <b>Ink index</b> is the order in which the file's inks will be printed (the ink with ink index 1 is at the bottom of the document and will be printed first).</p> <p>To find the ink index of a file:</p> <ol style="list-style-type: none"> <li>1. select the file in the Automation Engine Pilot's <b>Files</b> view,</li> <li>2. click ,</li> <li>3. in the <b>Info</b> dialog that opens, select <b>Inks</b> in the left panel.</li> </ol> <p>The order of the inks at right is the ink index (the topmost ink has an index of 1, the second of 2, etc.).</p> <p>Note that if you reorder the inks by one of the columns (for example by <b>Ink name</b>), they won't be ordered by ink index anymore. You will need to close that dialog and reopen it to see the ink index order again.</p>
<b>Spot ink index</b>	<p>The <b>Spot ink index</b> is the order in which a spot ink will be printed (when counting only spot inks and not process inks).</p> <p>For example, if the first 4 inks of the document are CMYK, the first spot ink will have 5 as <b>Ink index</b> but 1 as <b>Spot ink index</b>.</p>
<b>Ink type</b>	This can be for example Normal, Technical, Varnish...
<b>Printing method</b>	<p>If you have set a <b>Printing method</b> for an ink it will be shown here (this can be for example <i>Offset, Gravure, Flexo...</i> or any custom printing method you configured).</p> <p>See the Automation Engine documentation for more information about printing methods.</p>

For example, you can check whether the **Ink book is** process, whether the **Ink name is** yellow...

You can use as many criteria as you want.

2. You define how to combine your criteria into a rule. For example:

- If you want to output only process yellow, you should check for inks that match **both** of the criteria:

**Ink book is** process  
**Ink name is** yellow

- If you want to output both all process inks and all yellow inks, you should check for inks that match **either** of the criteria:

**Ink book is** process  
**Ink name is** yellow

- If you don't want to output any process inks or any yellow inks, you should check for inks that match **neither** of the criteria:

**Ink book is** process  
**Ink name is** yellow

**How Do I Build Rules?**

Build your rules the following way:

1. Choose how to combine the criteria in your rule:

- Select **All of the following are true** if you want to only select the inks that match **all** of the criteria you define.
- Select **Any of the following are true** if you want to select all the inks that match **at least one** of the criteria you define.
- Select **None of the following are true** if you want to only select the inks that match **none** of the criteria you define.

2. Define your first selection criterion.

You can select an ink based on its:

- **Ink name:** you can define if it **contains/begins with/ends with/is** a piece of text (alphanumerical characters), or if it **is empty**.
- **Ink book:** you can define if it **contains/begins with/ends with/is** a piece of text (alphanumerical characters), or if it **is empty**.
- **Ink index:** you can define if it **equals/is less than/is greater than** the number you enter, or **is between** the two numbers you enter (in this case the ink indexes you enter as boundaries are also selected).
- **Spot ink index:** you can define if it **equals/is less than/is greater than** the number you enter, or **is between** the two numbers you enter (in this case the spot ink indexes you enter as boundaries are also selected).
- **Ink type:** you can define if it **is** a piece of text (alphanumerical characters).
- **Printing method:** you can define if it **is** a piece of text (alphanumerical characters).

For example, you could use:	to:
<p><b>All of the following are true</b></p> <p><b>Ink book is</b> <code>designer</code></p>	select all inks from the "designer" ink book
<p><b>None of the following are true</b></p> <p><b>Ink name is</b> <code>crease</code></p>	exclude an ink called "crease"
<p><b>None of the following are true</b></p> <p><b>Ink type is</b> <code>Technical</code></p> <p><b>Ink type is</b> <code>Varnish</code></p>	exclude all technical and all varnish inks



**Tip:**

- You can enter several values to check for: just use a semicolon (;) between them. For example, to check for both inks called `Cyan` and inks called `Magenta`, choose **Ink name is** and enter `Cyan;Magenta`.
- When launching the task on a file, you can also click  to select one or more of the **Ink names/Ink books/Ink types/Printing methods** used in your input file(s). A criterion will automatically be created based on your selection.

3. Click + to add more criteria and define them.

To remove a criterion, click - next to it.



**Tip:** If you are launching the task on a single input file, you will see a table listing the **Selected document inks**, and another table with the **Document inks that are not selected** under the rules you defined.



**Attention:** If no ink is selected, you cannot launch the task.

### Switching How You Select Inks

You can switch between the two methods of selecting inks (*manually* and *using selection criteria*), and this will keep the same inks selected.

#### Switching from Selecting Inks Manually to Selecting Inks Using Selection Criteria

When switching from selecting inks manually to selecting inks using selection criteria, the task will translate your manual ink selection into rules, so that the same inks are selected (you can see them in the **Selected document inks** table).

The rules you get are based on the characteristics of the inks you selected.

For example, if you selected all the process colors but no spot color in your file, for an offset job, you will get the following rule:

**All of the following are true**

**Ink name is** `Cyan;Magenta;Yellow;Black`

**Ink book is** process  
**Ink type is** Normal  
**Printing method is** Offset



**Note:**

If you...

- first selected inks using selection criteria,
- then switched to manual selection without changing the selection,
- then switched back to selection criteria,

... then your rules will be kept.

If you did change the selection in manual mode, the task will automatically generate new rules.

**Switching from Selecting Inks Using Selection Criteria to Selecting Inks Manually**

When switching from selecting inks using selection criteria to selecting inks manually, all the inks selected by the rules you defined (the inks in the **Selected document inks** table) become selected manually.



**Note:** You can only switch to selecting inks manually when you are launching the task on a (single) file.

**Selecting Inks through Shuttle**

If you want to be able to decide which inks to RIP when submitting your input file *through Shuttle*, do the following:

**In Your Imaging Engine Ticket**

1. To make the ink selection a public parameter, you can either:
  - Right-click **Select Inks** and choose **Make Parameter Public**.
  - If you (are currently launching the ticket on a file and) have chosen to *select inks manually*, right-click the preview table under **Select Inks** and choose **Make Parameter Public**.

Select Inks: Manually

<input type="checkbox"/>	Ink Name	Ink Book	Ink Index	Spot Ink Ind...	Ink Type	Printing Met...
<input type="checkbox"/>	Cyan	process	1	-	Normal	Unknown
<input type="checkbox"/>	Magenta	process	2	-	Normal	Unknown
<input type="checkbox"/>	Yellow	process	3	-	Normal	Unknown
<input type="checkbox"/>	Black	process	4	-	Normal	Unknown
<input type="checkbox"/>	crease	Visualizer St...	5	1	Technical	Unknown
<input type="checkbox"/>	Cut	<unregistere...	6	2	Technical	Unknown

- If you have chosen to *use selection criteria*, right-click the rules builder under **Select Inks** and choose **Make Parameter Public**.

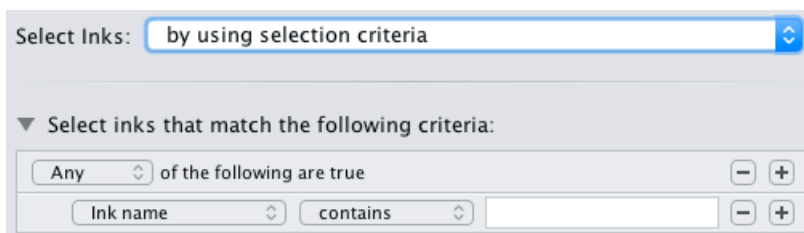

**Note:** You will not be able to create rules using Shuttle, you will only be able to select inks manually.

- Go to **Advanced > Manage Public Parameters...**, find the **Ink Selection** parameter at the bottom of the list, and drag it to the right hand side.

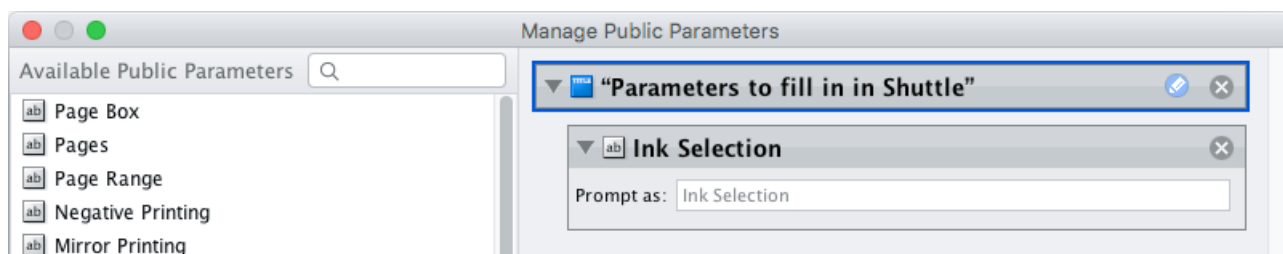

2. By default, the public parameter that appears in Shuttle will be called **Ink Selection**. You can change its name by:
  - right-clicking one of the elements mentioned above, selecting **Modify Public Parameter** and entering a new name,
  - if you are using the **Manage Public Parameters** window, entering the new name in **Prompt as**.
3. Make sure your ticket is also **Public**.

### In Shuttle

The ink selection parameter may look a bit different depending on which Shuttle you are using (the Shuttle standalone application or a Shuttle plug-in in an Editor application).

- In the Shuttle standalone, the ink selection parameter will look like this:

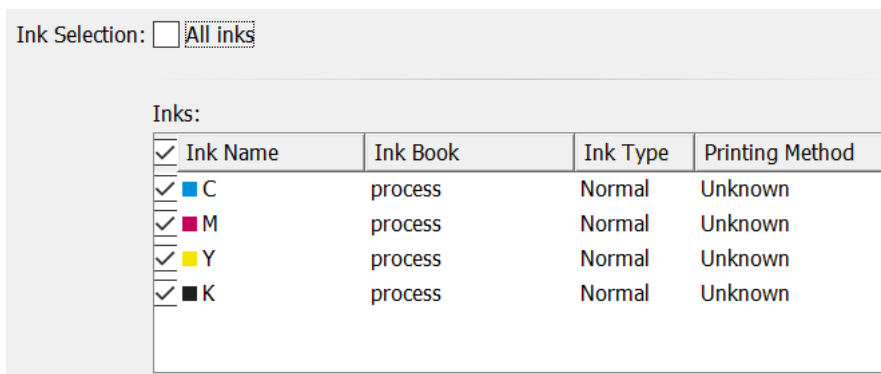

The table shows a preview of all inks in your input file, with their characteristics.

- To RIP all inks from your input file, either leave all inks selected in the preview table, or select **All inks** at the top (this will hide the preview table).
- To only RIP certain inks, make sure **All inks** is not selected, and deselect the input inks that you don't want to RIP.
- In ArtPro+ for example, the ink selection parameter will look like this:

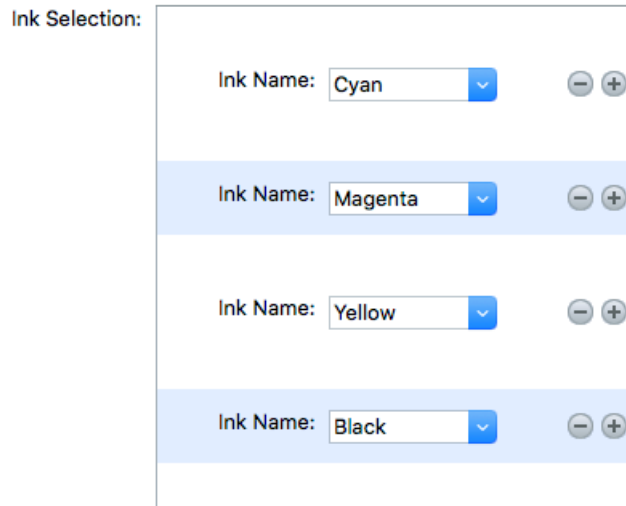

By default, all the inks from your input file will be RIP'ed, but you can remove any ink you don't want to RIP using the button.

### Sizes and Offsets

Use the **Sizes and Offsets** settings to define the size and relative positioning of your file, plate, press drum and paper.



**Note:** The default unit for size and positioning is the **Dimension** unit you have set in your Pilot preferences. You can type in a different unit and your values will be converted to that default unit.

1. If you are working with XMP metadata in your input files, you can use the plate and paper information from the metadata. To do this, select **Use plate and paper values from file**.
2. The **File Width** and **Height** information is calculated automatically, taking into account:
  - the *page box* you are RIP'ing,
  - the *rotation* you applied to your file,
  - the *distortion* you applied to your file.

When launching the task on a single file, the calculated values are shown in the ticket (unless any of the parameters used in the calculation are set using SmartNames).

3. For the **Plate** and **Paper**:



- If you selected **Use plate and paper values from file**, the size and positioning will be taken from the XMP metadata, and be uneditable (if the metadata doesn't contain this information, it will not be included in the CIP3 files).
- Otherwise you will be able to edit them manually (if the file has metadata that contains this information, it will still be filled in as a default).



**Tip:** The number of decimals you can set depends on your Pilot preference. You can also use simple calculations.



**Note:**

You will only be able to see the size and positioning values from the metadata when launching the task on a single file.

When launching it on several files at once or creating a ticket, those values will be retrieved when processing each file / when using the ticket.

4. You can always define the **Press** drum's **Width, Height, H Offset** (horizontal offset relative to the right edge of the plate) and **V Offset** (vertical offset relative to the bottom edge of the plate) manually.

When defining size and positioning values manually, you need to first select the component you want to define (**Plate, Press** and/or **Paper**).

A preview shows the components you selected (**File, Plate, Press** and/or **Paper**), and the size or offset you are currently defining is highlighted in blue.

For example, if you are entering the press drum width, you will see this:

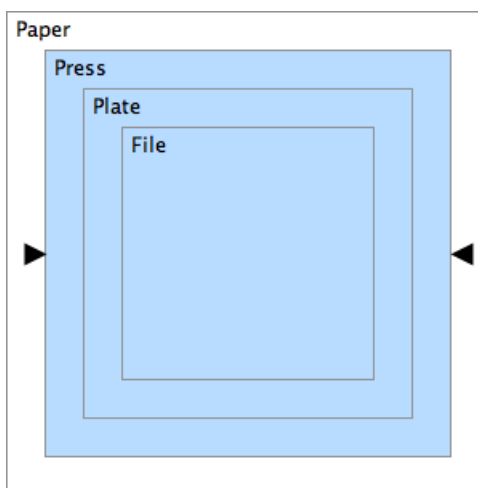

If you are entering the vertical offset between the file and the plate, you will see this:

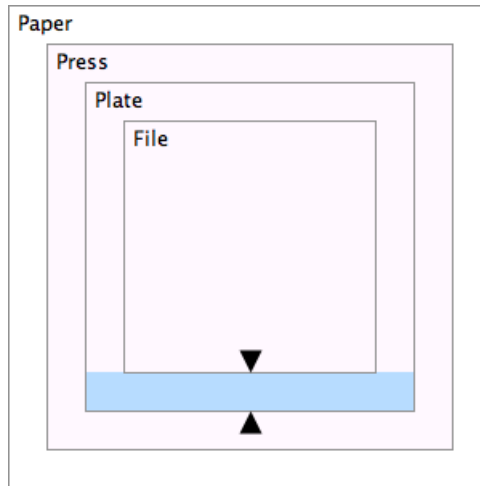

### Production Data

Use the **Production Data** settings to add job tracking information to your CIP3 files. This can help press operators control the workflow.

1. Add job tracking information to your CIP3 files. You can use text and/or SmartNames to add:
  - the **Customer Name**,
  - the job name in **Job Name Template**,
  - the code used for job identification in **Job Code Template**.



**Note:**

- If you use a SmartName that resolves to an empty value for **Job Name Template**, the task will end in error.  
Your press manufacturer may require you to enter this information in a specific format. Please check your press user manual.
- The **Customer Name** and **Job Code Template** settings are optional. If you don't need to add this information to the resulting .ppf file, you can leave them empty.

2. If desired, enter the number of **Copies** you will print of your job (the print volume).  
You must use a numerical value (*ninety* will not work). This is also an optional setting.
3. Enter the sheet name in **Sheet Name Template**.  
If you are working with several sheets, the **Sheet Name Template** needs to resolve to a unique name for each sheet.



**Note:**

- If you use a SmartName that resolves to an empty value for **Sheet Name Template**, the task will end in error.  
Your press manufacturer may require you to enter this information in a specific format. Please check your press user manual.

4. In **Guiding Sheet Edge**, select where your press' side guide (that guides the sheet edge into the correct position before printing) is located.

It can be at **Left** or at **Right**.



**Note:** If you don't need to add **Guiding Sheet Edge** information to the resulting .ppf file, leave **Undefined** as **Guiding Sheet Edge** value (do not put in an empty value).

5. In **Work Style**, select how multi-page jobs are printed (for example, on either one or both sides of a sheet or web, using either one or two press runs...).

- Choose **Simplex** if the job is only printed on one side (in one press run).
- Choose **Work and Back** if the job is printed "sheetwise". After the front side is printed, the sheet is turned, and the same gripper and side guide are used for printing the back.

This requires two plates (one for the front, one for the back) and two press runs.

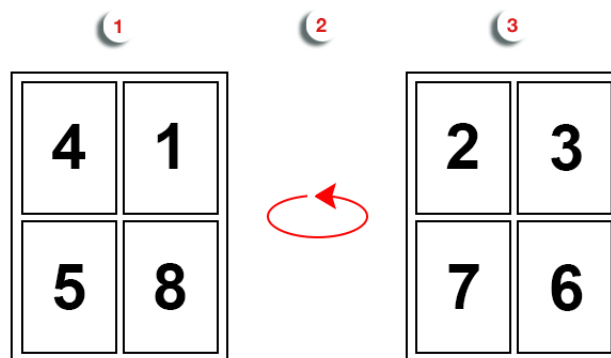

1. The front is printed during the first press run.
  2. The sheet is turned.
  3. The back is printed during the second press run.
- Choose **Perfecting** if your press prints paper on both sides at the same time (turning the sheet within one press run). This requires two plates.

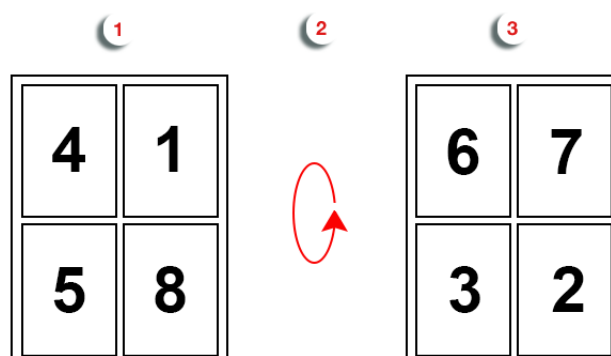

1. The front is printed.
2. The sheet is turned.

3. The back is printed during the same press run.

- Choose **Work and Turn** if all the pages are printed on the front, then the sheet is flipped horizontally (so that the sides are switched but the top edge remains in the same place), and all the pages are printed on the back.

This only requires one plate, but two press runs.

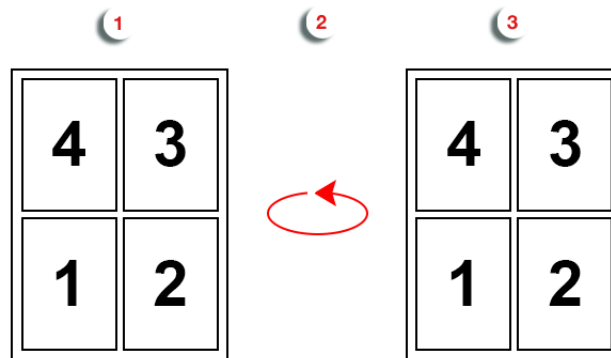

1. The pages are printed on the front during the first press run.

2. The sheet is turned horizontally.

3. The same pages are printed on the back during the second press run.

- Choose **Work and Tumble** if all the pages are printed on the front, then the sheet is flipped vertically (so that the top and bottom are switched but the sides remain in the same place), and all the pages are printed on the back.

This only requires one plate, but two press runs.

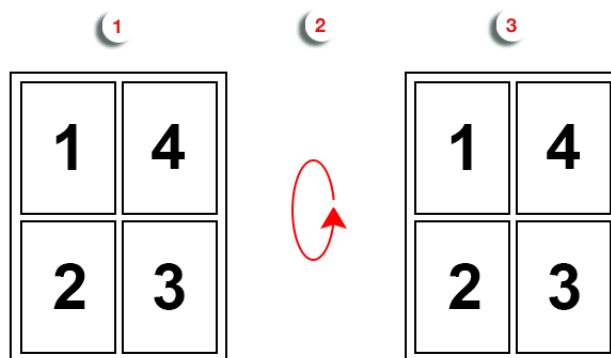

1. The pages are printed on the front during the first press run.

2. The sheet is turned vertically.

3. The same pages are printed on the back during the second press run.

- Choose **Work and Twist** if the sheet is printed twice on the front side: the first section is printed, then the sheet is rotated and the second section is printed. This only requires one plate, but two press runs.

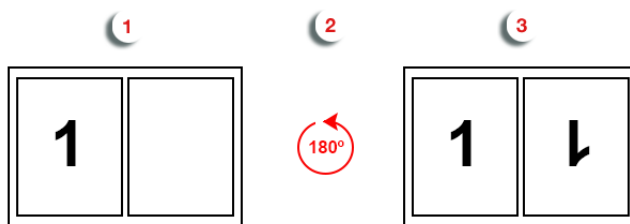

1. The content is printed on half of the front during the first press run.
2. The sheet is not turned, but rotated 180°.
3. The same content is printed on the other half of the front during the second press run.



**Note:** If you don't need to add **Work Style** information to the resulting .ppf file, leave **Undefined** as **Work Style** value (do not put in an empty value).

6. Select **Add ink Lab values** if you want to add the *Lab values* of the output separation to the .ppf file.

For example, it will add the Lab values of Cyan to the information contained in the Cyan .ppf file.



**Note:**

- For process colors, the task uses the Lab values defined in the output profile, unless you are using the *output intent* from the input file (in this case, it uses the Lab values defined in the output intent profile).

If you chose to use the output intent from the input file, but there is no output intent profile available in this file, the Lab values won't be added to the .ppf files and the task will end with a warning.

- For spot colors, the task uses the Lab values defined in *your color database* for this spot color.

If the spot color is not present in your color database (or is not in the ink book specified in the input file), the Lab values won't be added to the .ppf files and the task will end with a warning.

## Paper Data

Use the **Paper Data** settings to add information about the paper that will be used to your CIP3 files. All **Paper Data** settings are optional.

1. Enter the paper **Weight** you are planning on using for printing your RIP'ed files.

The default paper weight unit is g/m<sup>2</sup>. You can type in a different unit and the paper weight will be converted to g/m<sup>2</sup>.



**Note:**

For both **Weight** and **Thickness**:

- You must use a numerical value (`ninety` will not work). The number of decimals you can set depends on your Pilot preference.
- If you use a SmartName that doesn't resolve to a numerical value, the task will end in error.
- The task will also execute simple calculations.

2. Enter the paper **Thickness** you are planning on using for printing your RIP'ed files.

The default paper thickness unit is the **Dimension** unit you have set in your Pilot preferences. You can type in a different unit and the paper thickness will be converted to your default unit.

3. Enter the paper **Type** you are planning on using for printing your RIP'ed files.

You can use text and/or SmartNames.

4. Enter the **Color** of the printing paper, using **Lab** values.

See [How Are Colors Defined?](#) on page 1180 for more information about Lab values.

5. If you are working with a Heidelberg press, you can choose to add Heidelberg-press-specific parameters to your CIP3 files.

To do this, select **Add paper parameters for Heidelberg presses**. This makes the parameters underneath available.



**Note:** These parameters are not part of the CIP3 specification, but proprietary to Heidelberg, and used in the Heidelberg Prinect workflow (please contact Heidelberg for more information about the Prinect workflow).

- a) Enter the **Paper Name** of the substrate you are using on press.

- b) Choose the type of paper you are printing on:

- If the front and back of the paper are the same, choose the paper type in **Paper Type Front**, and leave **Paper Type Back** on **Undefined** (alternatively, you can choose the same type in **Paper Type Front** and **Paper Type Back**).
- If the front and back are different (for example they have a different coating), choose the correct types for front and back in **Paper Type Front** and **Paper Type Back**.

You can choose from: **Uncoated**, **Gloss Coated**, **Matt Coated**, **Web** and **Uncoated Yellowish**.

- c) You can also specify the paper **Grain Direction** (the direction of fibers in the sheet or web of paper). Select either:

- **Undefined** if you don't know your paper grain direction (or if this parameter is not supported by your Heidelberg Prinect software version),
- **Along Long Edge** if the grain runs along the long edge of the sheet (for "long grain paper"),
- **Along Short Edge** if the grain runs along the short edge of the sheet (for "short grain paper"),
- **Along X Direction** if the grain runs horizontally on the paper,

- **Along Y Direction** if the grain runs vertically on the paper.

## File Output

Use the **File Output** settings to define what type of output you want and where to output it.

You can set these through public parameters or using SmartNames.

1. Enter your output **File Name** and output **Folder**.



### Note:

- You can use Imaging Engine-specific SmartNames for the **File Name**.

For example, you can add the `[Printing Unit]` SmartName if you have added printing unit information in ArtPro+ . This way, the printing unit number will be included in the file name, making it easier for the press operator to know on which printing tower of the press each separation should be printed.

By default, the **File Name** is set to `[File]_[Sheet Number]_[ShortInk]` (which gives output file names like `Myfile_1_C.ppf`).

- The **File Name** and **Folder** can contain special characters (except `\ / : * ? < > " |`).
- The whole path to the output file (including the container, **Folder** and **File Name**) can be up to 255 characters.
- You can set a local or remote URL for the output **Folder**, but it must be an absolute path.
- If your output folder doesn't exist yet, the task will create it if the location you request is valid (you should place this folder on an Automation Engine container accessible by your Automation Engine user).

If the output folder creation fails, please check the task log for the full list of conditions and adapt your output folder path accordingly.

2. Define what to do if a file of the same name already exists in your output folder:

a) Click **Set Overwrite Policy...**

b) Choose what to do **If files exist already**. You can either:

- **Extend the file name** if you want to keep the existing output file and give the new output file a different name. In this case, your new output file name consists of:
  - the **Output file name** (the **File Name** you set earlier) - which is what the file would be called if no file with the same name existed,
  - a custom suffix that you can define using plain text and/or SmartNames (by default, this is `_c`, for "copy"),
  - an automatic suffix made of the three last digits of the task **ID**,



**Tip:**

To see the task ID of your tasks:

1. Go to the Pilot's **Tasks** pane (in the **Files** or **Tasks** view).
2. Go to **View > Select Columns in 'Tasks'...**
3. In the **Columns** dialog, select **Task ID** in the **Available columns** list and click  to move it to the **Show these columns:** list.
4. Click **OK**.
5. You now have a **Task ID** column in the **Tasks** pane, listing the task ID of all the tasks.

- the file extension.

For example, you are working with a single-page CMYK input file called `file.pdf`, and you have left the tasks' output **File Name** to its default value (`[File]_[Sheet Number]_[ShortInk]`). You are generating one CIP3 file per separation.

The first CIP3 files you generate will be called:

- `file_1_C.ppf`
- `file_1_M.ppf`
- `file_1_Y.ppf`
- `file_1_K.ppf`

If you generate output from this input file again, with the task 3669, and you have set the overwrite policy to **Extend the file name** with the default **Output File Name + \_c + ID** name, the new output files will be called:

- `file_1_C_c669.ppf`
- `file_1_M_c669.ppf`
- `file_1_Y_c669.ppf`
- `file_1_K_c669.ppf`

- **Overwrite** the existing file(s).
- **End the task in error**.



**Note:** If you use a SmartName to set this, it must resolve to `extend` or `0` (for **Extend the file name**), `overwrite` or `1` (for **Overwrite**), or `error` or `2` (for **End the task in error**).

c) Click **Set**.

3. In **File Assembly**, select how you want to generate the CIP3 files:

- Select **1 File Per Separation** if you want a CIP3 file for each separation of your input file. If your input file is multi-page and/or two-sided, this will generate one CIP3 file per separation, per page and per side.



For example, for a two-page file with two separations on each page, you will get a CIP3 file for each separation of the first page, and for each separation of the second page:

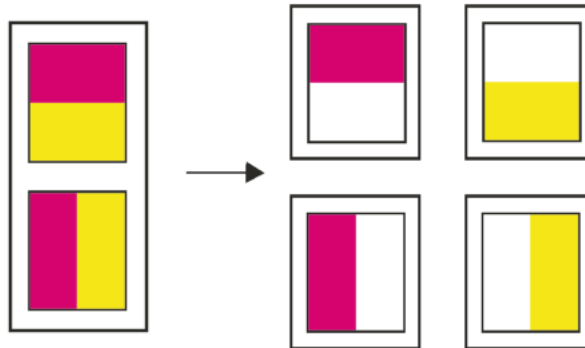

If your file is recto verso, you will also get CIP3 files for each separation on the back side of the file:

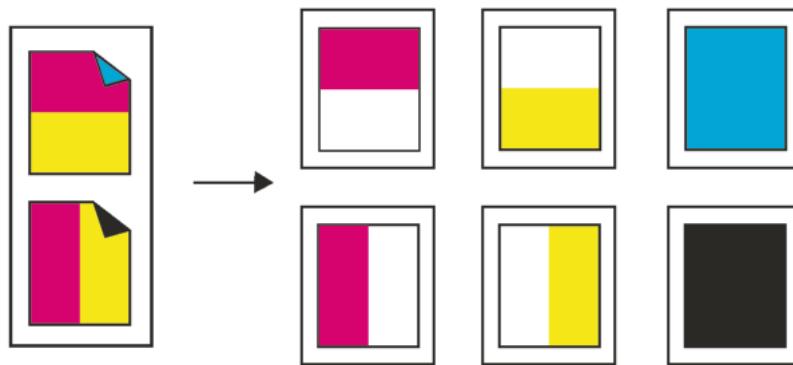

- Select **1 File Per Surface** if you want one CIP3 file for the front of your input file, and another CIP3 file for the back (for two-sided input files). For a multi-page input file the CIP3 file for each side contains all the pages of that side.

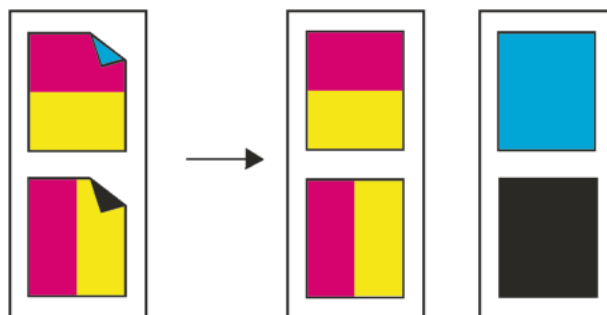

- Select **1 File Per Sheet** if you want one CIP3 file for both sides of each page/sheet of your input file.

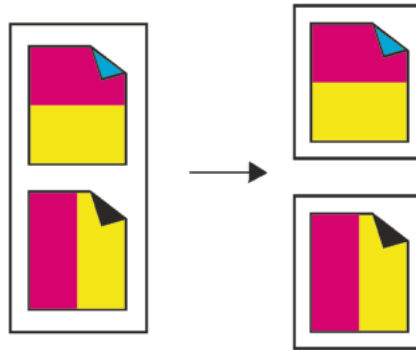

- Select **1 File Per Job** if you only want one CIP3 file for the whole input file (containing all the separations, pages, and both sides).

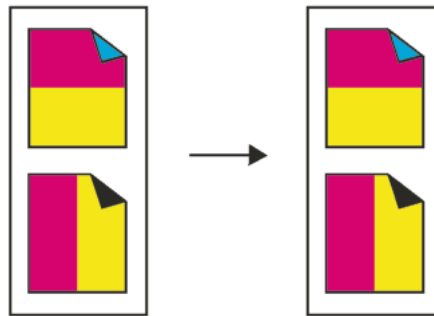

**Note:**

In case several separations are stored in a single file and printing units are defined for all separations in the input file, then the same order is maintained even in the CIP3 output file. Note that the printing unit order can only be ascending or descending.

If the order is not strictly ascending or descending, the normal separation order is followed and the task ends with a warning.

If printing unit is not defined for one of the separations, the printing unit order is followed for the separations but the task ends with a warning.

4. In **Side Control**, select what you want to create CIP3 files for, in case your input file is two-sided:
  - only for the **Front**,
  - only for the **Back**,
  - for both sides (**Alternate**).
5. In **Compression**, choose whether to compress your output files. You can either:
  - use the **PackBits** compression, a fast lossless compression method for graphic files.
  - output **Uncompressed** CIP3 files.
6. Choose the **Encoding** according to what your press supports: **Binary**, **ASCII** or **ASCII85**.

## Rendering

Use the **Rendering** settings to define how to handle images that have a different resolution than the output resolution, and set [other rendering options](#) to optimize your output.

1. Set the **Resolution** of your output files.



**Note:**

- The **Resolution** unit is taken from the general Automation Engine Preferences.
- The default resolution is 72 ppi, but you can enter values from 1 to 300 ppi (or equivalent in your unit). SmartNames must also resolve to a value in that range.
- Values in another unit than the one from the general Preferences will be recalculated, and values like 72ppi + 100ppm will be calculated correctly.

2. If your input file contains outlines, line art or contourized text, and you notice that they look too thick on print, we recommend you select the **Fine Line Rendering** option.

This will render objects with fine lines, for example Asian characters or barcodes, with a "thin fill".

You can set this option with a SmartName resolving to `true` to use **Fine Line Rendering** or `false` to use the standard rendering (also known as "fat fill").



**Note:**

If you have an older saved ticket (created in a version of Imaging Engine older than 22.11) with the outdated **Compensate for Outline Thickness** option selected, **Fine Line Rendering** will be used instead.

You will see a message about this:

- when opening the ticket,
- in the task details,
- in the log file.

When using this ticket, the task will end with a warning.

You can choose to not show this message again (in this case it won't be mentioned in the ticket, task details or log file, and the task won't end with a warning), but please note that this will apply to all users of that ticket.

3. If you experience problems with jagged edges, for example in small text, you can set an **Anti-aliasing** factor to smooth those edges.

See [Anti-Aliasing](#) on page 1188 for more information.

You can adjust the amount of anti-aliasing applied by choosing a factor of 2 to 8 (note that using a higher anti-aliasing factor may slow down processing).

You can also set this with a SmartName resolving to `None` (if you don't need anti-aliasing), or to the anti-aliasing factor you want (for example 2).

**Summary**

This shows a summary of all the settings you defined in the ticket.

- To show the settings from a tab, click + (on PC) or ► (on Mac) beside the tab name in the right pane. Click **Expand All** to show the settings from all tabs.
- To hide the settings from a tab, click - (on PC) or ▼ (on Mac) beside the tab name in the right pane. Click **Collapse All** to hide the settings from all tabs.

## 16.6. Third Party Licenses - Imaging Engine

---

This product includes lzw-ab.

Copyright (c) David Bryant  
All rights reserved.

Redistribution and use in source and binary forms, with or without modification, are permitted provided that the following conditions are met:

- \* Redistributions of source code must retain the above copyright notice, this list of conditions and the following disclaimer.
- \* Redistributions in binary form must reproduce the above copyright notice, this list of conditions and the following disclaimer in the documentation and/or other materials provided with the distribution.
- \* Neither the name of Conifer Software nor the names of its contributors may be used to endorse or promote products derived from this software without specific prior written permission.

THIS SOFTWARE IS PROVIDED BY THE COPYRIGHT HOLDERS AND CONTRIBUTORS "AS IS" AND ANY EXPRESS OR IMPLIED WARRANTIES, INCLUDING, BUT NOT LIMITED TO, THE IMPLIED WARRANTIES OF MERCHANTABILITY AND FITNESS FOR A PARTICULAR PURPOSE ARE DISCLAIMED. IN NO EVENT SHALL THE REGENTS OR CONTRIBUTORS BE LIABLE FOR ANY DIRECT, INDIRECT, INCIDENTAL, SPECIAL, EXEMPLARY, OR CONSEQUENTIAL DAMAGES (INCLUDING, BUT NOT LIMITED TO, PROCUREMENT OF SUBSTITUTE GOODS OR SERVICES; LOSS OF USE, DATA, OR PROFITS; OR BUSINESS INTERRUPTION) HOWEVER CAUSED AND ON ANY THEORY OF LIABILITY, WHETHER IN CONTRACT, STRICT LIABILITY, OR TORT (INCLUDING NEGLIGENCE OR OTHERWISE) ARISING IN ANY WAY OUT OF THE USE OF THIS SOFTWARE, EVEN IF ADVISED OF THE POSSIBILITY OF SUCH DAMAGE.

-----  
This product includes ICC Profiles.

Some ICC Profiles were created by FFEI Ltd. ([www.ffei.co.uk](http://www.ffei.co.uk)) using Fujifilm ColourKit Profiler Suite ([www.colourprofiling.com](http://www.colourprofiling.com))

-----  
This product includes ICC Profiles.

Some ICC profiles are copyright (C) by European Color Initiative, [www.eci.org](http://www.eci.org)

-----  
This product includes ICC Profiles.

Some ICC profiles are copyright (C) of WAN-IFRA, [www.wan-ifra.org](http://www.wan-ifra.org)

-----  
This product includes ICC Profiles.

Some ICC profiles are copyright (C) IDEAlliance(R). G7(R), GRACol(R) and

SWOP(R) are all registered trademarks of IDEAlliance(C).

-----

This product includes PANTONE Color Libraries.

PANTONE® and other Pantone trademarks are the property of Pantone LLC. Pantone is a wholly owned subsidiary of X-Rite, Incorporated.

-----

This product includes LibTIFF.

Copyright (c) 1988-1997 Sam Leffler  
 Copyright (c) 1991-1997 Silicon Graphics, Inc.

Permission to use, copy, modify, distribute, and sell this software and its documentation for any purpose is hereby granted without fee, provided that (i) the above copyright notices and this permission notice appear in all copies of the software and related documentation, and (ii) the names of Sam Leffler and Silicon Graphics may not be used in any advertising or publicity relating to the software without the specific, prior written permission of Sam Leffler and Silicon Graphics.

THE SOFTWARE IS PROVIDED "AS-IS" AND WITHOUT WARRANTY OF ANY KIND, EXPRESS, IMPLIED OR OTHERWISE, INCLUDING WITHOUT LIMITATION, ANY WARRANTY OF MERCHANTABILITY OR FITNESS FOR A PARTICULAR PURPOSE.

IN NO EVENT SHALL SAM LEFFLER OR SILICON GRAPHICS BE LIABLE FOR ANY SPECIAL, INCIDENTAL, INDIRECT OR CONSEQUENTIAL DAMAGES OF ANY KIND, OR ANY DAMAGES WHATSOEVER RESULTING FROM LOSS OF USE, DATA OR PROFITS, WHETHER OR NOT ADVISED OF THE POSSIBILITY OF DAMAGE, AND ON ANY THEORY OF LIABILITY, ARISING OUT OF OR IN CONNECTION WITH THE USE OR PERFORMANCE OF THIS SOFTWARE.

-----

This product includes FreeType.

Portions of this software are copyright (C) 2014 The FreeType Project ([www.freetype.org](http://www.freetype.org)) licensed under the FreeType License. All rights reserved.

-----

This product includes ICU.

Copyright (c) 1991-2023 Unicode, Inc. All rights reserved.  
 Distributed under the Terms of Use in <https://www.unicode.org/copyright.html>.

Permission is hereby granted, free of charge, to any person obtaining a copy of the Unicode data files and any associated documentation (the "Data Files") or Unicode software and any associated documentation (the "Software") to deal in the Data Files or Software without restriction, including without limitation the rights to use, copy, modify, merge, publish, distribute, and/or sell copies of the Data Files or Software, and to permit persons to whom the Data Files or Software are furnished to do so, provided that either (a) this copyright and permission notice appear with all copies of the Data Files or Software, or (b) this copyright and permission notice appear in associated Documentation.

THE DATA FILES AND SOFTWARE ARE PROVIDED "AS IS", WITHOUT WARRANTY OF ANY KIND, EXPRESS OR IMPLIED, INCLUDING BUT NOT LIMITED TO THE WARRANTIES OF MERCHANTABILITY, FITNESS FOR A PARTICULAR PURPOSE AND NONINFRINGEMENT OF THIRD PARTY RIGHTS. IN NO EVENT SHALL THE COPYRIGHT HOLDER OR HOLDERS INCLUDED IN THIS NOTICE BE LIABLE FOR ANY CLAIM, OR ANY SPECIAL INDIRECT OR CONSEQUENTIAL DAMAGES, OR ANY DAMAGES WHATSOEVER RESULTING FROM LOSS OF USE, DATA OR PROFITS, WHETHER IN AN ACTION OF CONTRACT, NEGLIGENCE OR OTHER TORTIOUS ACTION, ARISING OUT OF OR IN CONNECTION WITH THE USE OR PERFORMANCE OF THE DATA FILES OR SOFTWARE.

-----

Chinese/Japanese Word Break Dictionary Data (cjdict.txt)

```

# The Google Chrome software developed by Google is licensed under
# the BSD license. Other software included in this distribution is
# provided under other licenses, as set forth below.
#
# The BSD License
# http://opensource.org/licenses/bsd-license.php
# Copyright (C) 2006-2008, Google Inc.
#
# All rights reserved.
#
# Redistribution and use in source and binary forms, with or without
# modification, are permitted provided that the following conditions are met:
#
# Redistributions of source code must retain the above copyright notice,
# this list of conditions and the following disclaimer.
# Redistributions in binary form must reproduce the above
# copyright notice, this list of conditions and the following
# disclaimer in the documentation and/or other materials provided with
# the distribution.
# Neither the name of Google Inc. nor the names of its
# contributors may be used to endorse or promote products derived from
# this software without specific prior written permission.
#
#
# THIS SOFTWARE IS PROVIDED BY THE COPYRIGHT HOLDERS AND
# CONTRIBUTORS "AS IS" AND ANY EXPRESS OR IMPLIED WARRANTIES,
# INCLUDING, BUT NOT LIMITED TO, THE IMPLIED WARRANTIES OF
# MERCHANTABILITY AND FITNESS FOR A PARTICULAR PURPOSE ARE
# DISCLAIMED. IN NO EVENT SHALL THE COPYRIGHT OWNER OR CONTRIBUTORS BE
# LIABLE FOR ANY DIRECT, INDIRECT, INCIDENTAL, SPECIAL, EXEMPLARY, OR
# CONSEQUENTIAL DAMAGES (INCLUDING, BUT NOT LIMITED TO, PROCUREMENT OF
# SUBSTITUTE GOODS OR SERVICES; LOSS OF USE, DATA, OR PROFITS; OR
# BUSINESS INTERRUPTION) HOWEVER CAUSED AND ON ANY THEORY OF
# LIABILITY, WHETHER IN CONTRACT, STRICT LIABILITY, OR TORT (INCLUDING
# NEGLIGENCE OR OTHERWISE) ARISING IN ANY WAY OUT OF THE USE OF THIS
# SOFTWARE, EVEN IF ADVISED OF THE POSSIBILITY OF SUCH DAMAGE.
#
#
# The word list in cjdict.txt are generated by combining three word lists
# listed below with further processing for compound word breaking. The
# frequency is generated with an iterative training against Google web
# corpora.
#
# * Libtabe (Chinese)
#   - https://sourceforge.net/project/?group_id=1519
#   - Its license terms and conditions are shown below.
#
# * IPADIC (Japanese)
#   - http://chasen.aist-nara.ac.jp/chasen/distribution.html
#   - Its license terms and conditions are shown below.
#
# -----COPYING.libtabe ---- BEGIN-----
#
# /*
# * Copyright (c) 1999 TaBE Project.
# * Copyright (c) 1999 Pai-Hsiang Hsiao.
# * All rights reserved.
# *
# * Redistribution and use in source and binary forms, with or without
# * modification, are permitted provided that the following conditions
# * are met:
# *
# * . Redistributions of source code must retain the above copyright
# * notice, this list of conditions and the following disclaimer.
# * . Redistributions in binary form must reproduce the above copyright
# * notice, this list of conditions and the following disclaimer in
# * the documentation and/or other materials provided with the
# * distribution.
# * . Neither the name of the TaBE Project nor the names of its
# * contributors may be used to endorse or promote products derived
# * from this software without specific prior written permission.
# *
# * THIS SOFTWARE IS PROVIDED BY THE COPYRIGHT HOLDERS AND CONTRIBUTORS
# * "AS IS" AND ANY EXPRESS OR IMPLIED WARRANTIES, INCLUDING, BUT NOT
# * LIMITED TO, THE IMPLIED WARRANTIES OF MERCHANTABILITY AND FITNESS
# * FOR A PARTICULAR PURPOSE ARE DISCLAIMED. IN NO EVENT SHALL THE

```

```

# * REGENTS OR CONTRIBUTORS BE LIABLE FOR ANY DIRECT, INDIRECT,
# * INCIDENTAL, SPECIAL, EXEMPLARY, OR CONSEQUENTIAL DAMAGES
# * (INCLUDING, BUT NOT LIMITED TO, PROCUREMENT OF SUBSTITUTE GOODS OR
# * SERVICES; LOSS OF USE, DATA, OR PROFITS; OR BUSINESS INTERRUPTION)
# * HOWEVER CAUSED AND ON ANY THEORY OF LIABILITY, WHETHER IN CONTRACT,
# * STRICT LIABILITY, OR TORT (INCLUDING NEGLIGENCE OR OTHERWISE)
# * ARISING IN ANY WAY OUT OF THE USE OF THIS SOFTWARE, EVEN IF ADVISED
# * OF THE POSSIBILITY OF SUCH DAMAGE.
# */
#
# /*
# * Copyright (c) 1999 Computer Systems and Communication Lab,
# * Institute of Information Science, Academia
# * Sinica. All rights reserved.
# *
# * Redistribution and use in source and binary forms, with or without
# * modification, are permitted provided that the following conditions
# * are met:
# *
# * . Redistributions of source code must retain the above copyright
# * notice, this list of conditions and the following disclaimer.
# * . Redistributions in binary form must reproduce the above copyright
# * notice, this list of conditions and the following disclaimer in
# * the documentation and/or other materials provided with the
# * distribution.
# * . Neither the name of the Computer Systems and Communication Lab
# * nor the names of its contributors may be used to endorse or
# * promote products derived from this software without specific
# * prior written permission.
# *
# * THIS SOFTWARE IS PROVIDED BY THE COPYRIGHT HOLDERS AND CONTRIBUTORS
# * "AS IS" AND ANY EXPRESS OR IMPLIED WARRANTIES, INCLUDING, BUT NOT
# * LIMITED TO, THE IMPLIED WARRANTIES OF MERCHANTABILITY AND FITNESS
# * FOR A PARTICULAR PURPOSE ARE DISCLAIMED. IN NO EVENT SHALL THE
# * REGENTS OR CONTRIBUTORS BE LIABLE FOR ANY DIRECT, INDIRECT,
# * INCIDENTAL, SPECIAL, EXEMPLARY, OR CONSEQUENTIAL DAMAGES
# * (INCLUDING, BUT NOT LIMITED TO, PROCUREMENT OF SUBSTITUTE GOODS OR
# * SERVICES; LOSS OF USE, DATA, OR PROFITS; OR BUSINESS INTERRUPTION)
# * HOWEVER CAUSED AND ON ANY THEORY OF LIABILITY, WHETHER IN CONTRACT,
# * STRICT LIABILITY, OR TORT (INCLUDING NEGLIGENCE OR OTHERWISE)
# * ARISING IN ANY WAY OUT OF THE USE OF THIS SOFTWARE, EVEN IF ADVISED
# * OF THE POSSIBILITY OF SUCH DAMAGE.
# */
#
# Copyright 1996 Chih-Hao Tsai @ Beckman Institute,
# University of Illinois
# c-tsai4@uiuc.edu http://casper.beckman.uiuc.edu/~c-tsai4
#
# -----COPYING.libtabe-----END-----
#
# -----COPYING.ipadic-----BEGIN-----
#
# Copyright 2000, 2001, 2002, 2003 Nara Institute of Science
# and Technology. All Rights Reserved.
#
# Use, reproduction, and distribution of this software is permitted.
# Any copy of this software, whether in its original form or modified,
# must include both the above copyright notice and the following
# paragraphs.
#
# Nara Institute of Science and Technology (NAIST),
# the copyright holders, disclaims all warranties with regard to this
# software, including all implied warranties of merchantability and
# fitness, in no event shall NAIST be liable for
# any special, indirect or consequential damages or any damages
# whatsoever resulting from loss of use, data or profits, whether in an
# action of contract, negligence or other tortuous action, arising out
# of or in connection with the use or performance of this software.
#
# A large portion of the dictionary entries
# originate from ICOT Free Software. The following conditions for ICOT
# Free Software applies to the current dictionary as well.
#
# Each User may also freely distribute the Program, whether in its
# original form or modified, to any third party or parties, PROVIDED
# that the provisions of Section 3 ("NO WARRANTY") will ALWAYS appear

```

```
# on, or be attached to, the Program, which is distributed substantially
# in the same form as set out herein and that such intended
# distribution, if actually made, will neither violate or otherwise
# contravene any of the laws and regulations of the countries having
# jurisdiction over the User or the intended distribution itself.
#
# NO WARRANTY
#
# The program was produced on an experimental basis in the course of the
# research and development conducted during the project and is provided
# to users as so produced on an experimental basis. Accordingly, the
# program is provided without any warranty whatsoever, whether express,
# implied, statutory or otherwise. The term "warranty" used herein
# includes, but is not limited to, any warranty of the quality,
# performance, merchantability and fitness for a particular purpose of
# the program and the nonexistence of any infringement or violation of
# any right of any third party.
#
# Each user of the program will agree and understand, and be deemed to
# have agreed and understood, that there is no warranty whatsoever for
# the program and, accordingly, the entire risk arising from or
# otherwise connected with the program is assumed by the user.
#
# Therefore, neither ICOT, the copyright holder, or any other
# organization that participated in or was otherwise related to the
# development of the program and their respective officials, directors,
# officers and other employees shall be held liable for any and all
# damages, including, without limitation, general, special, incidental
# and consequential damages, arising out of or otherwise in connection
# with the use or inability to use the program or any product, material
# or result produced or otherwise obtained by using the program,
# regardless of whether they have been advised of, or otherwise had
# knowledge of, the possibility of such damages at any time during the
# project or thereafter. Each user will be deemed to have agreed to the
# foregoing by his or her commencement of use of the program. The term
# "use" as used herein includes, but is not limited to, the use,
# modification, copying and distribution of the program and the
# production of secondary products from the program.
#
# In the case where the program, whether in its original form or
# modified, was distributed or delivered to or received by a user from
# any person, organization or entity other than ICOT, unless it makes or
# grants independently of ICOT any specific warranty to the user in
# writing, such person, organization or entity, will also be exempted
# from and not be held liable to the user for any such damages as noted
# above as far as the program is concerned.
#
# -----COPYING.ipadic-----END-----
```

-----

Lao Word Break Dictionary Data (laodict.txt)

```
# Copyright (C) 2016 and later: Unicode, Inc. and others.
# License & terms of use: http://www.unicode.org/copyright.html
# Copyright (c) 2015 International Business Machines Corporation
# and others. All Rights Reserved.
#
# Project: https://github.com/rober42539/lao-dictionary
# Dictionary: https://github.com/rober42539/lao-dictionary/laodict.txt
# License: https://github.com/rober42539/lao-dictionary/LICENSE.txt
# (copied below)
#
# This file is derived from the above dictionary version of Nov 22, 2020
#
# -----
# Copyright (C) 2013 Brian Eugene Wilson, Robert Martin Campbell.
# All rights reserved.
#
# Redistribution and use in source and binary forms, with or without
# modification, are permitted provided that the following conditions are met:
#
# Redistributions of source code must retain the above copyright notice, this
# list of conditions and the following disclaimer. Redistributions in binary
# form must reproduce the above copyright notice, this list of conditions and
# the following disclaimer in the documentation and/or other materials
# provided with the distribution.
#
```



```
# THIS SOFTWARE IS PROVIDED BY THE COPYRIGHT HOLDERS AND CONTRIBUTORS
# "AS IS" AND ANY EXPRESS OR IMPLIED WARRANTIES, INCLUDING, BUT NOT
# LIMITED TO, THE IMPLIED WARRANTIES OF MERCHANTABILITY AND FITNESS
# FOR A PARTICULAR PURPOSE ARE DISCLAIMED. IN NO EVENT SHALL THE
# COPYRIGHT HOLDER OR CONTRIBUTORS BE LIABLE FOR ANY DIRECT,
# INDIRECT, INCIDENTAL, SPECIAL, EXEMPLARY, OR CONSEQUENTIAL DAMAGES
# (INCLUDING, BUT NOT LIMITED TO, PROCUREMENT OF SUBSTITUTE GOODS OR
# SERVICES; LOSS OF USE, DATA, OR PROFITS; OR BUSINESS INTERRUPTION)
# HOWEVER CAUSED AND ON ANY THEORY OF LIABILITY, WHETHER IN CONTRACT,
# STRICT LIABILITY, OR TORT (INCLUDING NEGLIGENCE OR OTHERWISE)
# ARISING IN ANY WAY OUT OF THE USE OF THIS SOFTWARE, EVEN IF ADVISED
# OF THE POSSIBILITY OF SUCH DAMAGE.
# -----
```

-----

Burmese Word Break Dictionary Data (burmesedict.txt)

```
# Copyright (c) 2014 International Business Machines Corporation
# and others. All Rights Reserved.
#
# This list is part of a project hosted at:
#   github.com/kanyawtech/myanmar-karen-word-lists
#
# -----
# Copyright (c) 2013, LeRoy Benjamin Sharon
# All rights reserved.
#
# Redistribution and use in source and binary forms, with or without
# modification, are permitted provided that the following conditions
# are met: Redistributions of source code must retain the above
# copyright notice, this list of conditions and the following
# disclaimer. Redistributions in binary form must reproduce the
# above copyright notice, this list of conditions and the following
# disclaimer in the documentation and/or other materials provided
# with the distribution.
#
#   Neither the name Myanmar Karen Word Lists, nor the names of its
#   contributors may be used to endorse or promote products derived
#   from this software without specific prior written permission.
#
# THIS SOFTWARE IS PROVIDED BY THE COPYRIGHT HOLDERS AND
# CONTRIBUTORS "AS IS" AND ANY EXPRESS OR IMPLIED WARRANTIES,
# INCLUDING, BUT NOT LIMITED TO, THE IMPLIED WARRANTIES OF
# MERCHANTABILITY AND FITNESS FOR A PARTICULAR PURPOSE ARE
# DISCLAIMED. IN NO EVENT SHALL THE COPYRIGHT HOLDER OR CONTRIBUTORS
# BE LIABLE FOR ANY DIRECT, INDIRECT, INCIDENTAL, SPECIAL,
# EXEMPLARY, OR CONSEQUENTIAL DAMAGES (INCLUDING, BUT NOT LIMITED
# TO, PROCUREMENT OF SUBSTITUTE GOODS OR SERVICES; LOSS OF USE,
# DATA, OR PROFITS; OR BUSINESS INTERRUPTION) HOWEVER CAUSED AND ON
# ANY THEORY OF LIABILITY, WHETHER IN CONTRACT, STRICT LIABILITY, OR
# TORT (INCLUDING NEGLIGENCE OR OTHERWISE) ARISING IN ANY WAY OUT OF
# THE USE OF THIS SOFTWARE, EVEN IF ADVISED OF THE POSSIBILITY OF
# SUCH DAMAGE.
# -----
```

-----

Time Zone Database

ICU uses the public domain data and code derived from Time Zone Database for its time zone support. The ownership of the TZ database is explained in BCP 175: Procedure for Maintaining the Time Zone Database section 7.

```
# 7. Database Ownership
#
# The TZ database itself is not an IETF Contribution or an IETF
# document. Rather it is a pre-existing and regularly updated work
# that is in the public domain, and is intended to remain in the
# public domain. Therefore, BCPs 78 [RFC5378] and 79 [RFC3979] do
# not apply to the TZ Database or contributions that individuals make
# to it. Should any claims be made and substantiated against the TZ
# Database, the organization that is providing the IANA
# Considerations defined in this RFC, under the memorandum of
# understanding with the IETF, currently ICANN, may act in accordance
# with all competent court orders. No ownership claims will be made
```

```
# by ICANN or the IETF Trust on the database or the code. Any person
# making a contribution to the database or code waives all rights to
# future claims in that contribution or in the TZ Database.
```

-----

Google double-conversion

Copyright 2006-2011, the V8 project authors. All rights reserved.  
Redistribution and use in source and binary forms, with or without  
modification, are permitted provided that the following conditions are  
met:

- \* Redistributions of source code must retain the above copyright notice, this list of conditions and the following disclaimer.
- \* Redistributions in binary form must reproduce the above copyright notice, this list of conditions and the following disclaimer in the documentation and/or other materials provided with the distribution.
- \* Neither the name of Google Inc. nor the names of its contributors may be used to endorse or promote products derived from this software without specific prior written permission.

THIS SOFTWARE IS PROVIDED BY THE COPYRIGHT HOLDERS AND CONTRIBUTORS "AS IS" AND ANY EXPRESS OR IMPLIED WARRANTIES, INCLUDING, BUT NOT LIMITED TO, THE IMPLIED WARRANTIES OF MERCHANTABILITY AND FITNESS FOR A PARTICULAR PURPOSE ARE DISCLAIMED. IN NO EVENT SHALL THE COPYRIGHT OWNER OR CONTRIBUTORS BE LIABLE FOR ANY DIRECT, INDIRECT, INCIDENTAL, SPECIAL, EXEMPLARY, OR CONSEQUENTIAL DAMAGES (INCLUDING, BUT NOT LIMITED TO, PROCUREMENT OF SUBSTITUTE GOODS OR SERVICES; LOSS OF USE, DATA, OR PROFITS; OR BUSINESS INTERRUPTION) HOWEVER CAUSED AND ON ANY THEORY OF LIABILITY, WHETHER IN CONTRACT, STRICT LIABILITY, OR TORT (INCLUDING NEGLIGENCE OR OTHERWISE) ARISING IN ANY WAY OUT OF THE USE OF THIS SOFTWARE, EVEN IF ADVISED OF THE POSSIBILITY OF SUCH DAMAGE.

-----

File: alocal.m4 (only for ICU4C)  
Section: pkg.m4 - Macros to locate and utilise pkg-config.

Copyright (c) 2004 Scott James Remnant <scott@netsplit.com>.  
Copyright (c) 2012-2015 Dan Nicholson <dbn.lists@gmail.com>

This program is free software; you can redistribute it and/or modify it under the terms of the GNU General Public License as published by the Free Software Foundation; either version 2 of the License, or (at your option) any later version.

This program is distributed in the hope that it will be useful, but WITHOUT ANY WARRANTY; without even the implied warranty of MERCHANTABILITY or FITNESS FOR A PARTICULAR PURPOSE. See the GNU General Public License for more details.

You should have received a copy of the GNU General Public License along with this program; if not, write to the Free Software Foundation, Inc., 59 Temple Place - Suite 330, Boston, MA 02111-1307, USA.

As a special exception to the GNU General Public License, if you distribute this file as part of a program that contains a configuration script generated by Autoconf, you may include it under the same distribution terms that you use for the rest of that program.

(The condition for the exception is fulfilled because ICU4C includes a configuration script generated by Autoconf, namely the `configure` script.)

-----

File: config.guess (only for ICU4C)

This file is free software; you can redistribute it and/or modify it under the terms of the GNU General Public License as published by

the Free Software Foundation; either version 3 of the License, or (at your option) any later version.

This program is distributed in the hope that it will be useful, but WITHOUT ANY WARRANTY; without even the implied warranty of MERCHANTABILITY or FITNESS FOR A PARTICULAR PURPOSE. See the GNU General Public License for more details.

You should have received a copy of the GNU General Public License along with this program; if not, see <<https://www.gnu.org/licenses/>>.

As a special exception to the GNU General Public License, if you distribute this file as part of a program that contains a configuration script generated by Autoconf, you may include it under the same distribution terms that you use for the rest of that program. This Exception is an additional permission under section 7 of the GNU General Public License, version 3 ("GPLv3").

(The condition for the exception is fulfilled because ICU4C includes a configuration script generated by Autoconf, namely the `configure` script.)

-----  
File: install-sh (only for ICU4C)

Copyright 1991 by the Massachusetts Institute of Technology

Permission to use, copy, modify, distribute, and sell this software and its documentation for any purpose is hereby granted without fee, provided that the above copyright notice appear in all copies and that both that copyright notice and this permission notice appear in supporting documentation, and that the name of M.I.T. not be used in advertising or publicity pertaining to distribution of the software without specific, written prior permission. M.I.T. makes no representations about the suitability of this software for any purpose. It is provided "as is" without express or implied warranty.

-----  
This product includes JBIG2Lib.

Portions of this product copyrights (C) 2002 Glyph & Cog, LLC.

-----  
This product includes JPEGLib.  
This software is copyright (C) 1991-2016, Thomas G. Lane, Guido Vollbeding.  
All Rights Reserved.

This software is based in part on the work of the Independent JPEG Group.

-----  
This product includes Little CMS.

Little CMS  
Copyright (c) 1998-2020 Marti Maria Saguer

Permission is hereby granted, free of charge, to any person obtaining a copy of this software and associated documentation files (the "Software"), to deal in the Software without restriction, including without limitation the rights to use, copy, modify, merge, publish, distribute, sublicense, and/or sell copies of the Software, and to permit persons to whom the Software is furnished to do so, subject to the following conditions:

The above copyright notice and this permission notice shall be included in all copies or substantial portions of the Software.

THE SOFTWARE IS PROVIDED "AS IS", WITHOUT WARRANTY OF ANY KIND, EXPRESS OR IMPLIED, INCLUDING BUT NOT LIMITED TO THE WARRANTIES OF MERCHANTABILITY, FITNESS FOR A PARTICULAR PURPOSE AND NONINFRINGEMENT. IN NO EVENT SHALL THE AUTHORS OR COPYRIGHT HOLDERS BE LIABLE FOR ANY CLAIM, DAMAGES OR OTHER LIABILITY, WHETHER IN AN ACTION OF CONTRACT, TORT OR OTHERWISE, ARISING FROM, OUT OF OR IN CONNECTION WITH THE

SOFTWARE OR THE USE OR OTHER DEALINGS IN THE SOFTWARE.

-----  
 This product includes libxml2.

Copyright (C) 1998-2012 Daniel Veillard. All Rights Reserved.

Permission is hereby granted, free of charge, to any person obtaining a copy of this software and associated documentation files (the "Software"), to deal in the Software without restriction, including without limitation the rights to use, copy, modify, merge, publish, distribute, sublicense, and/or sell copies of the Software, and to permit persons to whom the Software is furnished to do so, subject to the following conditions:

The above copyright notice and this permission notice shall be included in all copies or substantial portions of the Software.

THE SOFTWARE IS PROVIDED "AS IS", WITHOUT WARRANTY OF ANY KIND, EXPRESS OR IMPLIED, INCLUDING BUT NOT LIMITED TO THE WARRANTIES OF MERCHANTABILITY, FITNESS FOR A PARTICULAR PURPOSE AND NONINFRINGEMENT. IN NO EVENT SHALL THE AUTHORS OR COPYRIGHT HOLDERS BE LIABLE FOR ANY CLAIM, DAMAGES OR OTHER LIABILITY, WHETHER IN AN ACTION OF CONTRACT, TORT OR OTHERWISE, ARISING FROM, OUT OF OR IN CONNECTION WITH THE SOFTWARE OR THE USE OR OTHER DEALINGS IN THE SOFTWARE.

-----  
 This product includes OpenJPEG.

The copyright in this software is being made available under the 2-clauses BSD License, included below. This software may be subject to other third party and contributor rights, including patent rights, and no such rights are granted under this license.

Copyright (c) 2002-2014, Universite catholique de Louvain (UCL), Belgium  
 Copyright (c) 2002-2014, Professor Benoit Macq  
 Copyright (c) 2003-2014, Antonin Descampe  
 Copyright (c) 2003-2009, Francois-Olivier Devaux  
 Copyright (c) 2005, Herve Drolon, FreeImage Team  
 Copyright (c) 2002-2003, Yannick Verschuere  
 Copyright (c) 2001-2003, David Janssens  
 Copyright (c) 2011-2012, Centre National d'Etudes Spatiales (CNES), France  
 Copyright (c) 2012, CS Systemes d'Information, France

All rights reserved.

Redistribution and use in source and binary forms, with or without modification, are permitted provided that the following conditions are met:

1. Redistributions of source code must retain the above copyright notice, this list of conditions and the following disclaimer.
2. Redistributions in binary form must reproduce the above copyright notice, this list of conditions and the following disclaimer in the documentation and/or other materials provided with the distribution.

THIS SOFTWARE IS PROVIDED BY THE COPYRIGHT HOLDERS AND CONTRIBUTORS 'AS IS' AND ANY EXPRESS OR IMPLIED WARRANTIES, INCLUDING, BUT NOT LIMITED TO, THE IMPLIED WARRANTIES OF MERCHANTABILITY AND FITNESS FOR A PARTICULAR PURPOSE ARE DISCLAIMED. IN NO EVENT SHALL THE COPYRIGHT OWNER OR CONTRIBUTORS BE LIABLE FOR ANY DIRECT, INDIRECT, INCIDENTAL, SPECIAL, EXEMPLARY, OR CONSEQUENTIAL DAMAGES (INCLUDING, BUT NOT LIMITED TO, PROCUREMENT OF SUBSTITUTE GOODS OR SERVICES; LOSS OF USE, DATA, OR PROFITS; OR BUSINESS INTERRUPTION) HOWEVER CAUSED AND ON ANY THEORY OF LIABILITY, WHETHER IN CONTRACT, STRICT LIABILITY, OR TORT (INCLUDING NEGLIGENCE OR OTHERWISE) ARISING IN ANY WAY OUT OF THE USE OF THIS SOFTWARE, EVEN IF ADVISED OF THE POSSIBILITY OF SUCH DAMAGE.

-----  
 This product includes OpenSSL.

Copyright (c) 1998-2019 The OpenSSL Project. All rights reserved.

Redistribution and use in source and binary forms, with or without modification, are permitted provided that the following conditions are met:

1. Redistributions of source code must retain the above copyright notice, this list of conditions and the following disclaimer.
2. Redistributions in binary form must reproduce the above copyright notice, this list of conditions and the following disclaimer in the documentation and/or other materials provided with the distribution.
3. All advertising materials mentioning features or use of this software must display the following acknowledgment:  
"This product includes software developed by the OpenSSL Project for use in the OpenSSL Toolkit. (<http://www.openssl.org/>)"
4. The names "OpenSSL Toolkit" and "OpenSSL Project" must not be used to endorse or promote products derived from this software without prior written permission. For written permission, please contact [openssl-core@openssl.org](mailto:openssl-core@openssl.org).
5. Products derived from this software may not be called "OpenSSL" nor may "OpenSSL" appear in their names without prior written permission of the OpenSSL Project.
6. Redistributions of any form whatsoever must retain the following acknowledgment:  
"This product includes software developed by the OpenSSL Project for use in the OpenSSL Toolkit (<http://www.openssl.org/>)"

THIS SOFTWARE IS PROVIDED BY THE OpenSSL PROJECT ``AS IS'' AND ANY EXPRESSED OR IMPLIED WARRANTIES, INCLUDING, BUT NOT LIMITED TO, THE IMPLIED WARRANTIES OF MERCHANTABILITY AND FITNESS FOR A PARTICULAR PURPOSE ARE DISCLAIMED. IN NO EVENT SHALL THE OpenSSL PROJECT OR ITS CONTRIBUTORS BE LIABLE FOR ANY DIRECT, INDIRECT, INCIDENTAL, SPECIAL, EXEMPLARY, OR CONSEQUENTIAL DAMAGES (INCLUDING, BUT NOT LIMITED TO, PROCUREMENT OF SUBSTITUTE GOODS OR SERVICES; LOSS OF USE, DATA, OR PROFITS; OR BUSINESS INTERRUPTION) HOWEVER CAUSED AND ON ANY THEORY OF LIABILITY, WHETHER IN CONTRACT, STRICT LIABILITY, OR TORT (INCLUDING NEGLIGENCE OR OTHERWISE) ARISING IN ANY WAY OUT OF THE USE OF THIS SOFTWARE, EVEN IF ADVISED OF THE POSSIBILITY OF SUCH DAMAGE.

-----  
This product includes OpenSSL.

Copyright (C) 1995-1998 Eric Young ([eay@cryptsoft.com](mailto:eay@cryptsoft.com))  
All rights reserved.

Redistribution and use in source and binary forms, with or without modification, are permitted provided that the following conditions are met:

1. Redistributions of source code must retain the copyright notice, this list of conditions and the following disclaimer.
2. Redistributions in binary form must reproduce the above copyright notice, this list of conditions and the following disclaimer in the documentation and/or other materials provided with the distribution.
3. All advertising materials mentioning features or use of this software must display the following acknowledgement:  
"This product includes cryptographic software written by Eric Young ([eay@cryptsoft.com](mailto:eay@cryptsoft.com))"  
The word 'cryptographic' can be left out if the routines from the library being used are not cryptographic related :-).
4. If you include any Windows specific code (or a derivative thereof) from the apps directory (application code) you must include an acknowledgement:  
"This product includes software written by Tim Hudson ([tjh@cryptsoft.com](mailto:tjh@cryptsoft.com))"

THIS SOFTWARE IS PROVIDED BY ERIC YOUNG ``AS IS'' AND ANY EXPRESS OR IMPLIED WARRANTIES, INCLUDING, BUT NOT LIMITED TO, THE IMPLIED WARRANTIES OF MERCHANTABILITY AND FITNESS FOR A PARTICULAR PURPOSE ARE DISCLAIMED. IN NO EVENT SHALL THE AUTHOR OR CONTRIBUTORS BE LIABLE FOR ANY DIRECT, INDIRECT, INCIDENTAL, SPECIAL, EXEMPLARY, OR CONSEQUENTIAL DAMAGES (INCLUDING, BUT NOT LIMITED TO, PROCUREMENT OF SUBSTITUTE GOODS OR SERVICES; LOSS OF USE, DATA, OR PROFITS; OR BUSINESS INTERRUPTION) HOWEVER CAUSED AND ON ANY THEORY OF LIABILITY, WHETHER IN CONTRACT, STRICT LIABILITY, OR TORT (INCLUDING NEGLIGENCE OR OTHERWISE) ARISING IN ANY WAY OUT OF THE USE OF THIS SOFTWARE, EVEN IF ADVISED OF THE POSSIBILITY OF SUCH DAMAGE.

-----  
 This product includes LibTIFF.

Copyright (c) 1988-1997 Sam Leffler  
 Copyright (c) 1991-1997 Silicon Graphics, Inc.

Permission to use, copy, modify, distribute, and sell this software and its documentation for any purpose is hereby granted without fee, provided that (i) the above copyright notices and this permission notice appear in all copies of the software and related documentation, and (ii) the names of Sam Leffler and Silicon Graphics may not be used in any advertising or publicity relating to the software without the specific, prior written permission of Sam Leffler and Silicon Graphics.

THE SOFTWARE IS PROVIDED "AS-IS" AND WITHOUT WARRANTY OF ANY KIND, EXPRESS, IMPLIED OR OTHERWISE, INCLUDING WITHOUT LIMITATION, ANY WARRANTY OF MERCHANTABILITY OR FITNESS FOR A PARTICULAR PURPOSE.

IN NO EVENT SHALL SAM LEFFLER OR SILICON GRAPHICS BE LIABLE FOR ANY SPECIAL, INCIDENTAL, INDIRECT OR CONSEQUENTIAL DAMAGES OF ANY KIND, OR ANY DAMAGES WHATSOEVER RESULTING FROM LOSS OF USE, DATA OR PROFITS, WHETHER OR NOT ADVISED OF THE POSSIBILITY OF DAMAGE, AND ON ANY THEORY OF LIABILITY, ARISING OUT OF OR IN CONNECTION WITH THE USE OR PERFORMANCE OF THIS SOFTWARE.

-----  
 This product includes XercesC.

NOTICE file corresponding to section 4(d) of the Apache License, Version 2.0, in this case for the Apache Xerces distribution.

This product includes software developed by  
 The Apache Software Foundation (<http://www.apache.org/>).

Portions of this software were originally based on the following:  
 - software copyright (c) 1999, IBM Corporation., <http://www.ibm.com>.

-----  
 This product includes XMP Toolkit.  
 Copyright (c) 2020, Adobe  
 All rights reserved.

Redistribution and use in source and binary forms, with or without modification, are permitted provided that the following conditions are met:

1. Redistributions of source code must retain the above copyright notice, this list of conditions and the following disclaimer.
2. Redistributions in binary form must reproduce the above copyright notice, this list of conditions and the following disclaimer in the documentation and/or other materials provided with the distribution.
3. Neither the name of the copyright holder nor the names of its contributors may be used to endorse or promote products derived from this software without specific prior written permission.

THIS SOFTWARE IS PROVIDED BY THE COPYRIGHT HOLDERS AND CONTRIBUTORS "AS IS" AND ANY EXPRESS OR IMPLIED WARRANTIES, INCLUDING, BUT NOT LIMITED TO, THE IMPLIED WARRANTIES OF MERCHANTABILITY AND FITNESS FOR A PARTICULAR PURPOSE ARE DISCLAIMED. IN NO EVENT SHALL THE COPYRIGHT HOLDER OR CONTRIBUTORS BE LIABLE FOR ANY DIRECT, INDIRECT, INCIDENTAL, SPECIAL, EXEMPLARY, OR CONSEQUENTIAL DAMAGES (INCLUDING, BUT NOT LIMITED TO, PROCUREMENT OF SUBSTITUTE GOODS OR SERVICES; LOSS OF USE, DATA, OR PROFITS; OR BUSINESS INTERRUPTION) HOWEVER CAUSED AND ON ANY THEORY OF LIABILITY, WHETHER IN CONTRACT, STRICT LIABILITY, OR TORT (INCLUDING NEGLIGENCE OR OTHERWISE) ARISING IN ANY WAY OUT OF THE USE OF THIS SOFTWARE, EVEN IF ADVISED OF THE POSSIBILITY OF SUCH DAMAGE.

-----  
 This product includes zlib.

(C) 1995-2022 Jean-loup Gailly and Mark Adler

This software is provided 'as-is', without any express or implied

warranty. In no event will the authors be held liable for any damages arising from the use of this software.

Permission is granted to anyone to use this software for any purpose, including commercial applications, and to alter it and redistribute it freely, subject to the following restrictions:

1. The origin of this software must not be misrepresented; you must not claim that you wrote the original software. If you use this software in a product, an acknowledgment in the product documentation would be appreciated but is not required.
2. Altered source versions must be plainly marked as such, and must not be misrepresented as being the original software.
3. This notice may not be removed or altered from any source distribution.

Jean-loup Gailly  
jloup@gzip.org

Mark Adler  
madler@alumni.caltech.edu

-----  
This product includes ZXing C++ Library.

Copyright 2016 ZXing authors.  
<https://github.com/zxing>

-----

# 17. Flexo CTP Device Workflow

---

## 17.1. Intro

---

Concepts, workflow, terminology, etc.

### 17.1.1. CDI (LEN, LENX) or Not CDI (TIFF)

#### Workflow to an Esko CDI

Automation Engine offers a range of tools that help automate platemaking on a CDI. Using these tools brings these benefits:

- A view on the CDI device within the Pilot, including its job load and queue management.
- Automatic merging of LEN(X) files onto a CDI plate.
- Detailed feedback from the CDI about the exposed plates, including waste factors.
- Easy monitoring of status of a plates of a specific job, even when spread over several CDI plates or merged with separations from other jobs.
- Easy remaking of CDI plates (full or partial).

#### Workflow to a non-Esko Flexo CTP device

A big part of this workflow is also possible when making the flexo plate on a non-Esko device, for example a CTP device from Kodak.

This device can also be used in the same Plate Merger system. These merged plates also become visible on the Merged Plates view.

The main workflow differences are:

- The merged plate is a TIFF file i.s.o. a LEN(X) file.



**Note:** Remark that the RIP'ed data that you submit to the plate merger also in this case need to be LEN files. The resulting merged plate will be TIFF.



**Important:** LENX files are LEN files that contain Crystal screens. The plate merger will error when he is asked to make a layout for a TIFF device, which does not have the required 'Crystal' technology.

- There is no feedback from the CTP device.





**Attention:** In this version, a workflow to a TIFF device still requires you to configure at least one CDI device!

### 17.1.2. Terminology

While learning about the involved tools, it is important to understand the used terminology, especially the terms **Press Plate** and **Merged Plate**.

- **CDI:** Cyrel Digital Imager, Esko's digital flexo plate imager. Learn about CDIs [on this web page](#).
- **DFS:** Digital Flexo Suite. A set of interactive applications to *manually* prepare LEN files and expose them on a CDI.
- **DFS Merger:** The Merger is one of the applications of the DFS. An operator uses it to prepare LEN files, merge them onto a layout, create a LEN file of that layout and send it to the queue of the **DFS Exposer**.

One DFS Merger can drive several CDIs, unless it is installed on the PC of the CDI itself (in which case it is called 'Grapholas Merger').

- **LEN(X) file:** RIP output format that can be imaged on a CDI. Esko Imaging Engine can create LEN(X) files. These files can also be the output of a DFS application like PlatePatcher.
- **Merging:** Placing LEN(X) files next to each other on a same layout, typically as many as possible, to avoid wasting plate material.

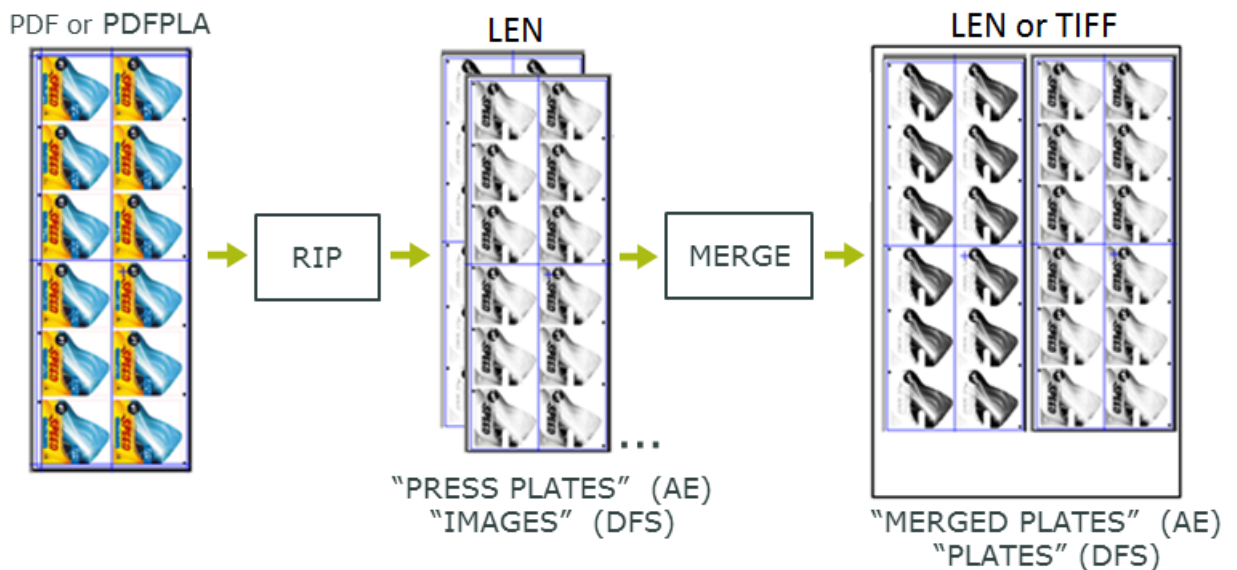

- **"Press Plate":** A RIP'ed separation (LEN(X) file) that can be merged before being imaged on a flexo device.

The term "press" emphasizes that this is a plate in the view of a printer: even when several are merged with other Press Plates onto a CDI plate, they will be split/cut again after imaging and processing, so that every Press Plate can end up as *one plate on the press*.

On the DFS, this is called an "image". The terminology in the DFS applications is focused purely on the CDI (not on the whole workflow up to the printer).

On Automation Engine, a LEN(X) file becomes a Press Plate the moment it was submitted to the Plate Merger.

A "**Press Plate Set**" is a group of press plates that belongs to the same job.

- "**Merged Plate**": A LEN(X) or TIFF file on which several Press Plates were merged. A Merged Plate can contain several separations of a same job or even separations from other jobs. After imaging and processing, a Merged Plate will be cut to end up with several plates for the press operator.

On the DFS, this is called a "Plate", because this is one plate when being imaged on the CDI.

When the chosen device is not a CDI, the merger creates a TIFF file.

- **Kongsberg**: *Kongsberg cutting tables* are typically used for their precision and productivity in cutting for example plates with staggered cuts or PlatePatcher layouts.

### 17.1.3. Manual Workflow (DFS only)

This page first illustrates the manual workflow where DFS uses local LEN files to make the Merged Plates for a CDI.

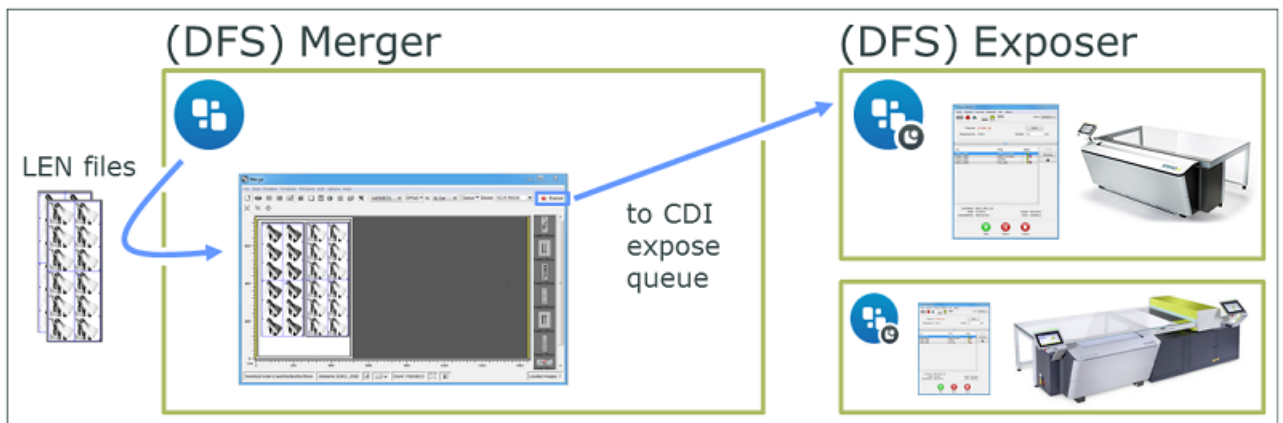

These are the main process steps:

1. LEN files are written into the "working folder" of the DFS station. These files can be created by an Imaging Engine or FlexRip, or could have arrived from a remote site.
2. The DFS **Merger** operator
  - selects the CDI and plate type that the layout will be exposed on. He then selects the LEN files ("images") from that "working folder" and loads them into the Merger.
  - then manually creates a layout for the selected CDI plate and/or uses the "Auto Arrange" feature to get some help with that.
  - can use interactive editing functions like crop, cut, rotate etc.
3. When a final layout is made for that CDI, he presses "Expose!" to send it to the CDI's expose queue (the **Exposer** application).
4. The CDI operator mounts a flexo plate on the CDI and uses the Exposer application to start the exposure.
5. After exposure, the plate goes through its post processing steps and may be cut before being sent to the press room or shipped to the printer.
6. DFS also writes HTML files containing the history of the exposed plates and their plate usage. These can be used by an external system for job status or production statistics.

### 17.1.4. Automatic workflow (using AE)

In this workflow, Automation Engine replaces the use of a DFS Merger and provides extra tools to view the history of this output.

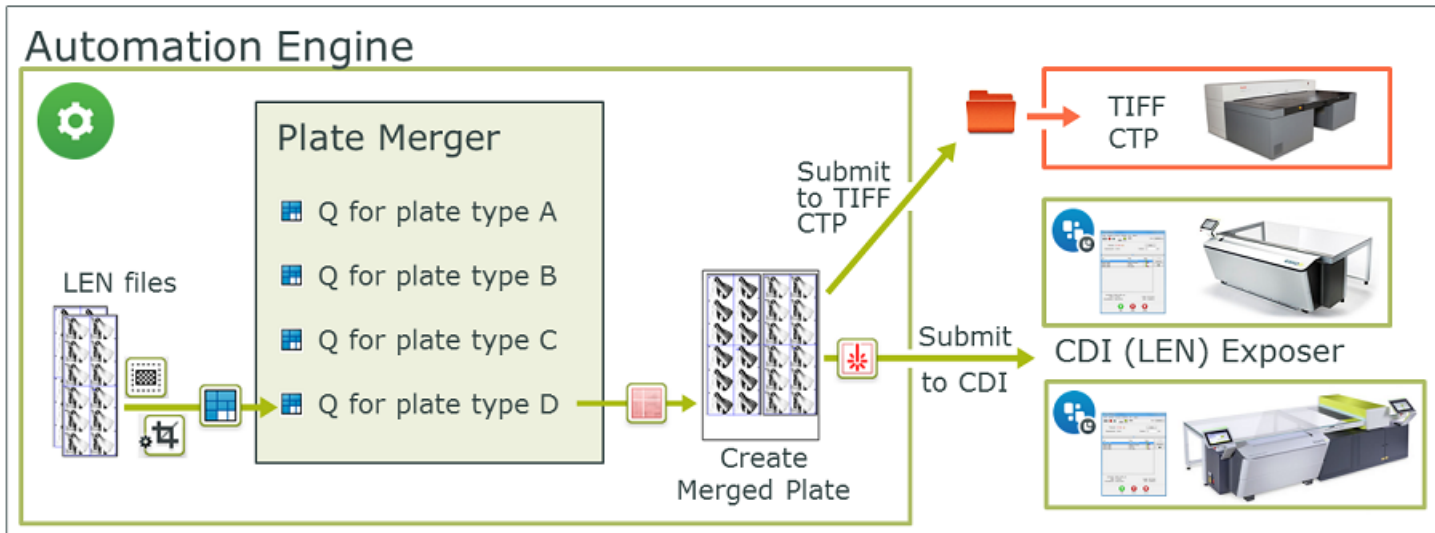

1. LEN files arrive in Automation Engine. These were created by an Imaging Engine (or FlexRip). These files can come directly from the RIP (in-house or remote) or can also come from the DFS application PlatePatcher.



**Note:** When LEN files were already edited in PlatePatcher, the version of PlatePatcher (Digital Flexo Suite) must be 20.0.16 or higher.

2. Editing LEN files can be automated using the [Add Margins](#) and [Crop](#) tasks.
3. LEN files are *submitted to a specific queue of the Plate Merger*, together with parameters defining how and when they should be merged. A **Merge Queue** typically represents a plate type and can offer several sizes of that plate type.



**Note:** You can also choose to add [test strips](#) or [margins](#) to the layout.

4. When the Merge Queue decided on a layout, it starts a workflow that creates the Merged Plate LEN file and then submits that file to the CDI's device queue.



**Note:** In this workflow, creating the Merged Plate LEN file is a task on your Automation Engine server and not on the standalone DFS computer.

When the selected device is not a CDI, the workflow creates a TIFF file on a dedicated output folder.

5. The CDI operator uses the **Exposer** application to expose the Merged Plate.



**Note:** When so configured in the [Plate Merger configuration](#), any successful imaging of a CDI plate automatically triggers a workflow that submits the related cutting XML file to the Kongsberg's iPC. Learn more [here](#).

6. In the Pilot's Views bar, the category 'Flexo' offers some extra views that support this workflow:

- The [Merged Plates](#) view shows all Merged Plates, in their different states. In this view you can also easily resubmit plates back to the CTP queue, typically in cases where you need to remake them. You can choose to resubmit the whole merged plate or only selected press plates.
  - The [Press Plates](#) view helps you to overview which LEN separations are or have been part of this workflow.
  - The [Press Plate Sets](#) view adds an extra job order perspective.
7. Reporting back to business systems. This workflow can also automatically sends reports to external systems, both about what's happening on the device and about the status of the Job order. Learn more in [Reporting to Business Systems](#) on page 1489.

### 17.1.5. Semi-Automatic Workflow (manual intervention)

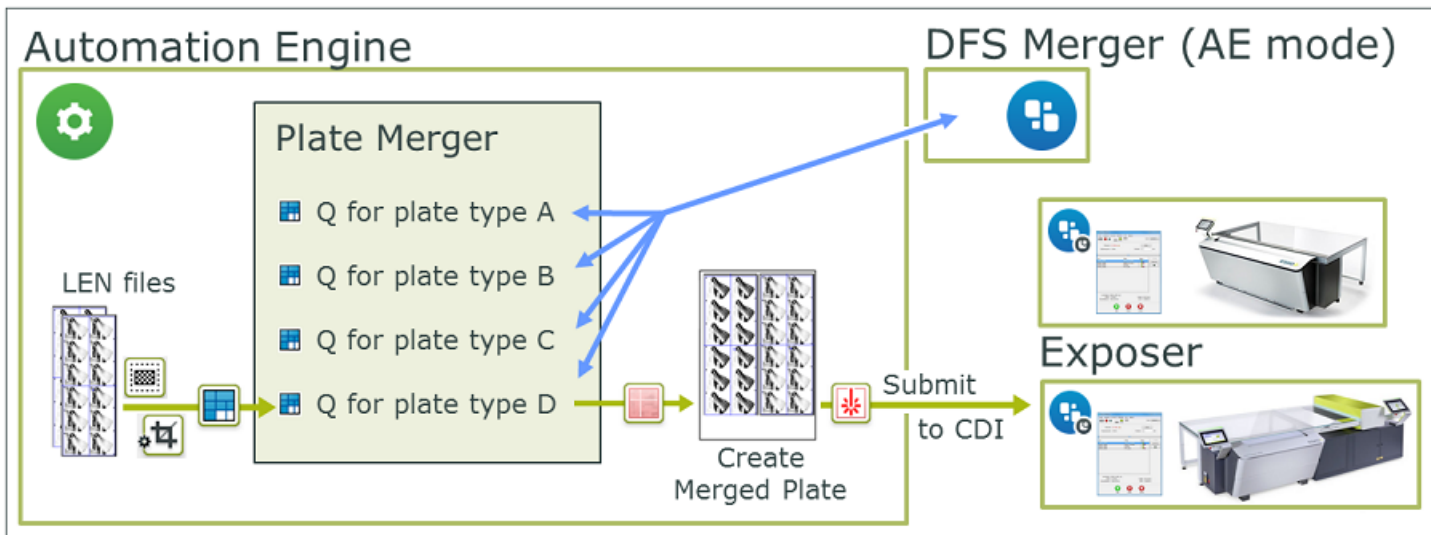

Even when you use the tools in Automation Engine, you can still use the DFS Merger to manually intervene. Some examples:

- When you want to use one of the partial flexo plates available in the plate room. Learn more in [Plate Merger](#) on page 1501.
- When you want to optimize plate usage by adding (smaller) Press Plates ("Images") that only recently arrived in the queue and have a lower priority.



**Note:** This manual intervention to optimize the plate usage can sometimes be replaced by using the option to [reconsider](#) already merged plates: this puts all its press plates back into the automatic merger and so makes them re-merge with any (small) new arrivals in that queue.

In the following cases, merging cannot be done by using the tools within Automation Engine. It has to be done with the manual DFS Merger application, using local LEN files:

- In a DFS PlatePatcher workflow (corrugated).

- To manually crop LEN files.

Workflow steps:

1. When using the [DFS Merger in AE Manual mode](#), the DFS user first selects one of the existing Plate Merger queues on Automation Engine. To prevent any conflicts, the selected merge queue is automatically paused.
2. The DFS user loads the Press Plates ("Images") that are present in the selected merge queue and manually creates a layout with (some of) those.
3. When finished, the DFS user clicks "Expose". This automatically makes Automation Engine launch the workflow that was defined for that merge queue. From this point on, the workflow is identical as when working fully automatic: a merged plate LEN file is made from that layout and is then sent to the CDI device queue.



**Attention:** Limitations in the DFS Merger when in AE manual mode:

- It is not possible to manually Crop the LEN files in the DFS Merger when it is set in [AE Manual mode](#). Consider using Automation Engine's [Crop LEN File](#) task.
- You cannot use the Viewer in DFS/PlatePrep to view the LEN files. Use the Automation Engine Viewer instead.
- Whether a LEN file is allowed to be rotated or not is controlled by the merge queue setting and/or by the value set for 'Rotation' in the 'Submit to Plate Merger' task. If rotation is not allowed, the rotation button in the DFS Merger application will be greyed out.

## 17.1.6. Introducing Flexo CTP Device related Views and Tasks

This page offers an overview of dedicated tasks and Pilot Views that enable the automation in flexo CTP platemaking.



Find their detailed documentation in [Flexo CTP related Views](#) and [Flexo CTP related Tasks](#).

### Views and Tools

-  [Devices](#). This view shows an overview of your configured CDIs or flexo CTP TIFF devices (and possibly other device types). It shows their general status and also the content of their expose queue.





**Note:** This view is also available from the **Tools** menu, which means you can also open it as a separate window next to the Pilot.





-  [Plate Merger](#). This view is where you configure and monitor **Merge Queues**. A merge queue calculates possible layouts of press plates (RIP'ed separations) onto a merged plate (CTP plate layout).
-  [Device Queues](#). This view shows the device queues in a graphical way. You see details about their queue items and you can manage them (delete, change order, resubmit or, when possible, move to another queue).



**Note:** This view is also available from the **Tools** menu, which means you can also open it as a separate window next to the Pilot.



-  **Press Plates.** This view lists details about all press plates that were submitted to the plate merger. It offers smart filtering, viewing and easy navigation to the job they belong to or to the merged plate they are/were part of. You can also resubmit press plates back to the plate merger.
-  **Press Plate Sets.** This view shows the press plates in a job order context. For example a CSR (Customer Service Representative) can here monitor all jobs needing flexo press plates and see how many have been imaged yet.
-  **Merged Plates.** This view shows details about all merged plates. When you select one and think you can (now) get a more optimized layout than the one you see, you can choose to resubmit all its press plates back to the plate merger. Double click a selection to zoom in and see a large preview of its layout and details about their press plates. In this view, you can also resubmit a selection of press plates back to the plate merger.

**Tasks**

-  **Add Margins to LEN file.** Use this task to make sure there is enough room between press plates on a merged plate. Alternatively, this can be also be done by adding *Press Plate Margins* in the merge queue.
-  **Crop LEN file.** Use this task to crop LEN files to the first image pixel or to the staggered cut line.
-  **Submit to Plate Merger.** Use this task to submit LEN files (press plates) to the plate merger.
-  **Create Merged Plate.** When the plate merger decides on a layout, it uses this task to create the LEN or TIFF file of that layout.
-  **Submit to Flexo Device.** This task submits the LEN of the merged plate to a CDI device queue. In case of a TIFF flexo CTP, it submits the TIFF file of the merged plate to a folder that that device is monitoring.

**17.1.7. Main Steps in Setting Up this Workflow**

Once you have a working setup of DFS (or Grapholas) software, then these are the main steps to set up this workflow in the Pilot:

1. **Create one or more Devices.** In the *Devices* View, click  to add a device for every flexo device you have.
2. **Create Plate Merger queues.** In the *Plate Merger*, click  to add a merge queue for every type of flexo plate that you use on any of the configured devices.
  - Pick the type of plate from the list that is automatically retrieved from the configured CDI(s).



**Attention:** In this version, even when making a merge queue that you will use for a TIFF device, you still need to pick a plate type from a list of plates that are configured on a CDI. This list is read from a CDI's DFS within your network. In other words: to use a TIFF device in this workflow, you also require to have at least one CDI configured.

- Then set all the other merger settings for every queue.



**Tip:** When you have more than one CTP, it is not necessary to make a specific merge queue for each CTP device. This would prevent the load balancing: the system can then no longer decide to pick the least busy device.

3. **Create an output workflow for the merge queue(s).** In the *Tickets* view, create a workflow that starts with *creating the Merged Plate file* (LEN or TIFF is automatically decided by the chosen device) and that ends with *submitting that file to a flexo device*.



**Attention:** When adding more steps to this workflow, make sure to still respect the required input files for both these mandatory task steps. Learn more in these [notes on Output Workflows](#).

4. **Attach the workflow to the merge queue(s).** Complete the setup of the merge queue(s) by adding the output workflow that you created in the previous step.
5. **Test.** Select a group of LEN files, open a [Submit to Plate Merger](#) task, select the right plate type and launch the task. When the fill rate is too small, use "Force Out" to see the next steps in the workflow. You should see one or more new entries in the device queue.
6. **Adapt your existing RIP workflows** by adding a [Submit to Plate Merger](#) task at their end.

All the tools used in this workflow summary are described in detail in the pages on the [Views](#) and [Tasks](#).

### 17.1.8. Reporting to Business Systems

When making digital plates, this type of information is often asked for:

- Statistics on plate usage: type, waste, etc.
- Statistics about the CDI: Till when is this CDI planned to be busy? How much time has it been exposing this week and at what resolution?
- Job order information: Are all press plates for this job exposed on the CDI yet? What is the plate usage/waste for this job?

All this information can be sent to any external system by workflows that are automatically launched at specific events in a CDI workflow. Learn more in [Plate Merger Configuration](#) on page 1510.

This information can be delivered via XML files, [web service calls](#), or even [direct database interaction](#). Learn more about such integration techniques in the chapter [Integrating with External Systems](#) on page 1769.

### 17.1.9. Removed CDI Related Tools

In Automation Engine 14, the "CDI View" and the "Make Plate on CDI task" enabled a minimal connection to a CDI.

These tools were removed in Automation Engine 16 when the current tools became available.



## 17.2. Flexo Device related Views

These tools and tasks and their concepts were introduced [here](#).

### 17.2.1. Devices (CDI)



**Tip:** You can also open the view **Devices** as a Tool: Go to **Tools > Devices** to monitor and manage your devices in a separate window.

#### Adding a CDI Device

Follow these steps to add a CDI device:

1. In the Views bar, in the group '**Setup**', open the view **Devices**.
2. Click . Select the category **Flexo - CDI** and click **OK**.
3. In **Server**, type in the name or the IP address of the computer of that CDI (the one where its Grapholas is installed).



**Attention:** The computer that drives the CDI must be configured to use a fixed IP address. This can be achieved by either setting a fixed IP address on that computer or by preserving a fixed IP address on the DHCP server.

4. Click **Add** to confirm. The blue status box of the newly created device appears.



**Note:** Older CDI devices show up in a lighter blue color.



**Note:** Adding a CDI device requires a license per device.



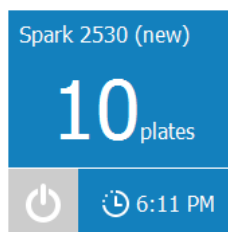

#### Information and functionality



The device status box shows following information that it gets directly from the Exposer application of that CDI:

- The **name of the device**. By default this is the name of the computer where the DFS or Grapholas software was detected. Open the **Info** panel to change it to a custom name.
- The **amount of merged plates in the expose queue**. This is the amount of jobs in its expose queue (exposing and waiting).
- A **device status icon**.





- : Retrieving the status.
- : The device is offline. There is no connection with the device's computer (switched off, network problem, etc.).
- : The device is online. It could be idle or busy imaging.
-  The **Estimated time** when the current job load will be finished (how long the CDI is scheduled to be busy).



**Attention:** CDIs with a Grapholas version 12 up to 14.0 can not feed a correct estimation of the exposing time to Automation Engine. Therefore, in this view, you will not see this information for these older devices.

Right-click a status box to choose one of these options:

- **Info** (or press ). This dialog shows details about the device (version, settings, etc.). You can add a **Description** to illustrate or help identify this device. Click **Advanced Options** for a detailed technical list of its parameters.
- **Delete** (or press ). You will be asked to confirm.
- **New Device....** An alternative to clicking .

## CDI Device Status in an External Dashboard

### Concept

Some customers are using a dashboard where they monitor their company's activity. This dashboard can be a part of their business system or it can be custom-built. These sites often also want to see the status of their CDI devices in that same interface.



**Note:** To get detailed information about specific plate consumption and job status, learn more in [Tab 'Reporting'](#) on page 1512.

The external system that shows the dashboard can ask Automation Engine for the CDI status via HTTP GET calls. It can so collect the same information that you can see in the [CDI Device View](#):

- **General** device status (idle or exposing).
- The **amount of merged plates in the expose queue**. This is the amount of jobs in its expose queue (exposing and waiting).
- The **estimated time** when the current job load will be finished (how long the CDI is scheduled to be busy).

Regular updates of the status of all CDI queues can be retrieved via **Server-Sent Events (SSE)**.

### Syntax

- Getting the status of a specific CDI:
  - In a browser, go to `<name-of-AE-server>:4412/FPL/cdi/<name-of-CDI-device>` .
  - An example:



- Continuously getting the status of all CDIs via Server-Sent Events (SSE):
  - In a browser, go to <name-of-AE-server>: 44111/CDI. You will first see an info page. In there, click the link to the Server-Sent Events to see the live status of all CDIs.
  - Per CDI device, the following information is returned:
    - **NAME:** Name of the machine.
    - **IP:** IP-address of the machine.
    - **STATE: OFFLINE:** When the machine cannot be reached.
    - **IDLE: TRUE:** When the machine is not exposing.
    - **IDLE: FALSE:** When the machine is exposing.
    - **QUEUELENGTH:** Number of entries in the expose queue.
    - **TIME:** The time in seconds to empty the queue (on condition of continuously exposing from now onwards).

An example:

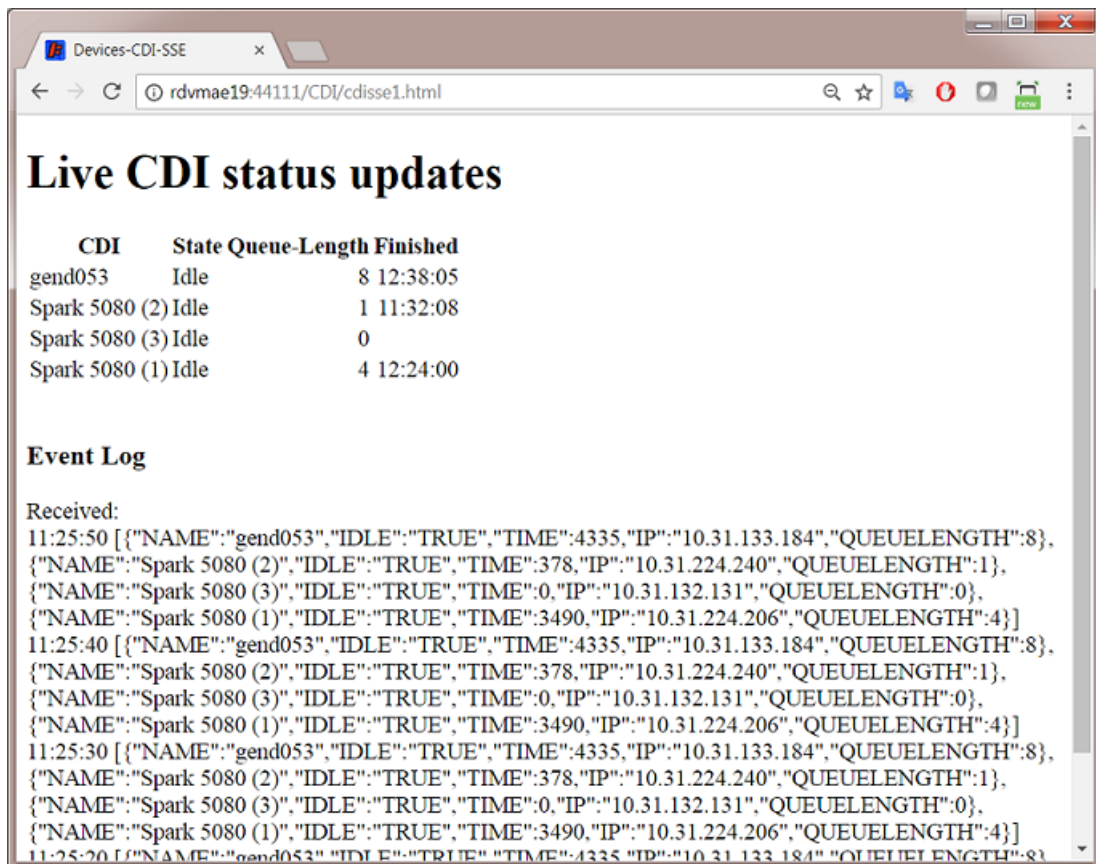

Ask your browser to view the **source** of this web page. This will reveal the JavaScript that translates the incoming events to the readable table.

An example (in the browser 'Chrome'):

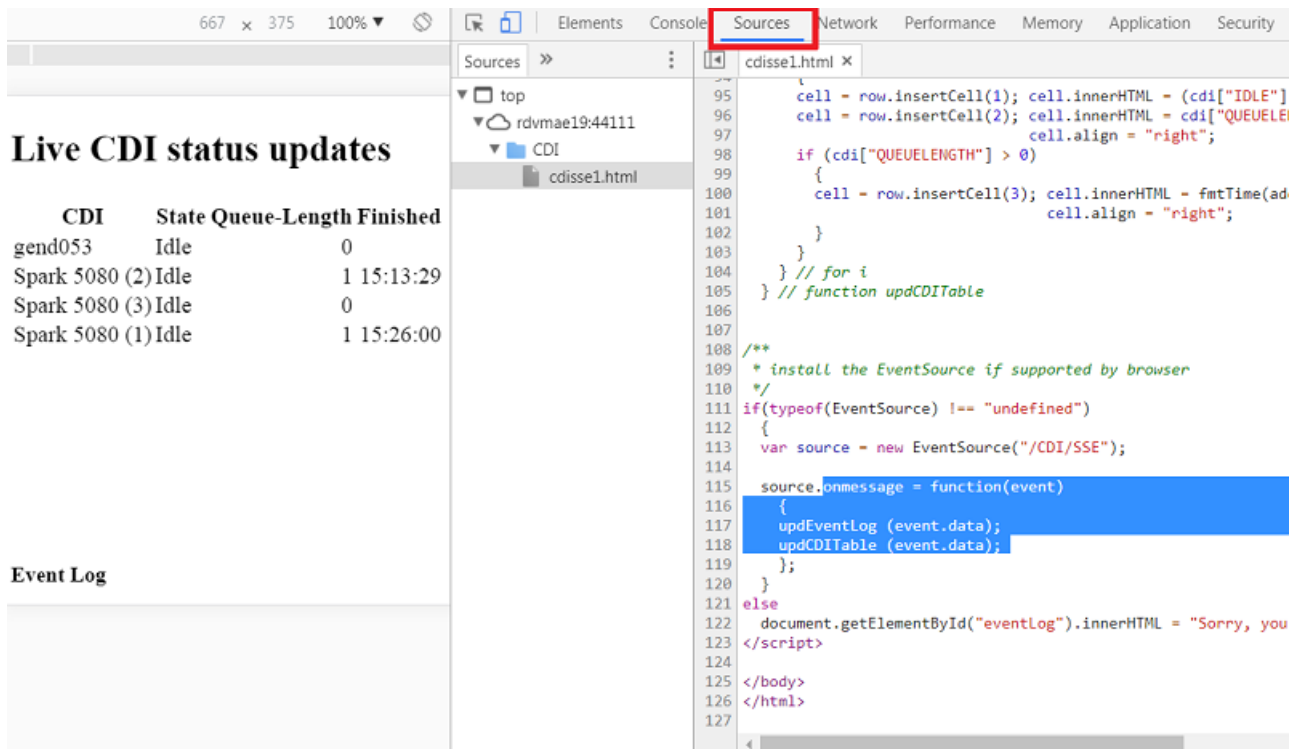

**Live CDI status updates**

CDI	State	Queue-Length	Finished
gend053	Idle	0	
Spark 5080 (2)	Idle	1	15:13:29
Spark 5080 (3)	Idle	0	
Spark 5080 (1)	Idle	1	15:26:00

**Event Log**

```

95     cell = row.insertCell(1); cell.innerHTML = (cdi["IDLE"])
96     cell = row.insertCell(2); cell.innerHTML = cdi["QUEUELE
97         cell.align = "right";
98     if (cdi["QUEUELENGTH"] > 0)
99     {
100         cell = row.insertCell(3); cell.innerHTML = fmtTime(ad
101             cell.align = "right";
102     }
103 }
104 } // for i
105 } // function updCDITable
106
107
108 /**
109  * install the EventSource if supported by browser
110  */
111 if(typeof(EventSource) !== "undefined")
112 {
113     var source = new EventSource("/CDI/SSE");
114
115     source.onmessage = function(event)
116     {
117         updEventLog (event.data);
118         updCDITable (event.data);
119     };
120 }
121 else
122     document.getElementById("eventLog").innerHTML = "Sorry, you
123 </script>
124
125 </body>
126 </html>
127
  
```

### 17.2.2. Devices (TIFF)



**Note:** We here only describe the differences with adding an Esko CDI device, as described above.

#### Adding a Flexo TIFF Device

Follow these steps to add an offline Flexo CTP device that you will send TIFF files to.

1. In the Devices view, click on .
2. Select the category **Flexo - TIFF** and click **OK**.
3. Fill in the device's properties:

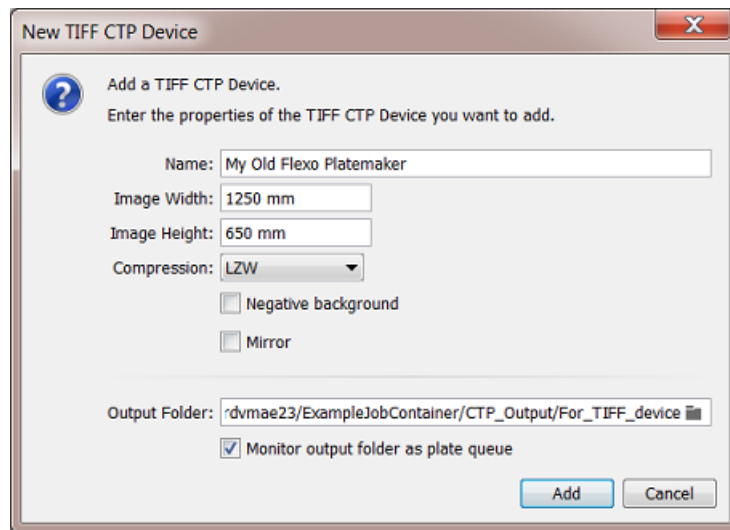

- **Name:** Type a name for this TIFF device.
- **Image Width** and **Image Height:** Define the (maximum) size of the output TIFF (merged plate) for this device to expose.
- **Compression:** Select the compression for this output TIFF file.
- **Negative background:** Should this TIFF file have a negative background?
- **Mirror:** Should the data be mirrored on that TIFF file?
- **Output Folder:** Define where all output TIFF files (merged plates) for this device should be written.
- **Monitor output folder as plate queue:** Select this to enable the device's status box to show this information:
  - Number of plates. This is the number of TIFF files currently in the output folder.
  - A rough time estimate. There is no link with the device to obtain any idea how long it will take to expose these plates. Therefore, the system uses a default estimate of 30 minutes per plate and 3 minutes in between plates.
- Click **Add** to confirm. An olive green status box of the new device appears.

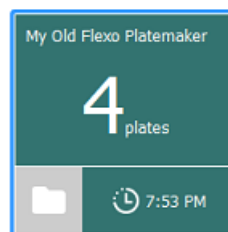



**Important:** To change the name of a device, right-click the device's status box and choose **Rename**.

### 17.2.3. Press Plates



**Note:** The terms "Press Plates" and "Merged Plates" were introduced in the page on [Terminology](#) on page 1483.

#### Concept

This view lists all the Press Plates in rows. These are the LEN files that were submitted to the Plate Merger. Select one to see a preview and some key information in a pane on the right.

When your Pilot is in a specific Job mode, you only see the press plates of that Job.

Depending on the type of information you are looking for, you may want to see the entries grouped differently. An extra line then separates the groups. To set your preference, select any entry, right-click and choose:

- **Grouped by Press Plate Set.** This groups all entries that were submitted together by the same [Submit to Plate Merger](#) task. Because these entries are likely coming from the same graphics file, the focus of this view is more on the delivery of these press plates: It helps answer questions like 'Can we move them to the press?' or 'Can we ship them soon?'

A similar view is offered in the [Press Plate Sets view](#), but there you see a different kind of information in the right pane.

- **Grouped by Merged Plate.** This groups all entries with the other press plates that are or were part of the same merged plate. This focus of this view is more on the CTP device.

#### Columns



**Note:** As in many views in the Pilot, you can

- re-arrange columns by dragging their title to a new position
- sort them by clicking on a column title
- right-click a column title and choose to **Hide** this one or any other. In the list that appears, select **Select Columns...** if you want to change or re-arrange multiple items.
- use filters and optionally save them as a [Smart View](#).
- define your preferred unit in **Edit > Preferences > Units**.

Several of these columns only get their value as the press plate progresses through its workflow.

- **File Name:** Name of the LEN file.
- **Folder:** Full path where the LEN file resides.
- **Order ID:** The order ID of the Job that the LEN files of the press plates reside in.
- **Resolution:** Resolution of the LEN file.
- **Size:** V-H size of the LEN file. (This is the size the plate merger uses when calculating layouts).
- **Device:** Name of CTP device that the layout containing this press plate was made for. This field is empty when the state is still "In Plate Merger".

- **Ink name:** As read from the LEN file's XMP metadata.
- **Rotation:** Rotation as requested in the [Submit to Plate Merger](#) task: 0, 90 or **mq** (= "Set by Merge Queue").
- **State** of each press plate:



**Tip:** Hover your mouse over a status icon to read its meaning.



**Tip:** When using the filter, click CTRL to filter on multiple statuses.

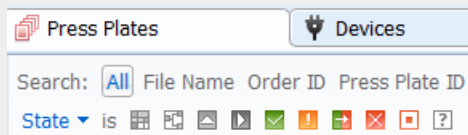

- **In Plate Merger:** Still an entry in a merge queue of the plate merger.
- **In Output Workflow:** Part of a merged plate that is currently in its [merge queue's output workflow](#).
- **Queued on CDI:** Part of a merged plate that is in a CDI device queue.
- **Exposing on CDI:** Part of a merged plate that is being exposed on the CDI.
- **Exposed:** Part of a merged plate that was successfully exposed on the CDI.
- **Exposed (Warning):** Part of a merged plate that was exposed on the CDI with a warning.
- **Error (In output workflow):** Part of a merged plate that encountered an error in its [merge queue's output workflow](#).
- **Error:** Part of a merged plate that was exposed on the CDI with an error.
- **Cancelled:** Part of a merged plate that was cancelled (removed) from the CDI's "Exposer" queue.
- **Unknown:** Status unknown.
- **Imaging Technology:** The technology that was requested for this LEN file when it was [submitted to the plate merger](#).
- **Manufacturer, Thickness** and **Type:** Plate specifications, as retrieved from DFS or Grapholas during the workflow.
- Timing
  - **Due date:** Time specified in the [Submit to Plate Merger task](#). When none was specified, a due date is set at 3 days after the submitting to the merger.
  - **Finished:** Time when this press plate was finished exposing on the CDI.
  - **Launched:** Time when this press plate was submitted to the plate merger.
- Plate usage, retrieved from the layout XML created by the plate merger:
  - **Used Area:** Area that this press plate uses on the merged plate.
  - **Waste:** Area of this press plate that is not used area. (press plate margins, cut marks area)

- **% Used Area:** % of used area of the merged plate that this press plate is part of.
- **% Waste:** % of unused area of the merged plate that this press plate is part of.



**Note:** In previews of the merged plate, the waste area is shown in pink.

- When this press plate also requested a cutting workflow, these fields will get their values when that workflow is executed on the Kongsberg:
  - **Cutting Flow:** Name of cutting workflow chosen in the [Submit to Plate Merger task](#).
  - **Cut State:** (Not) Ready for Cutting, Done, Error or Cancelled.
- Custom fields (names defined in the [Plate Merger item in the Configure tool](#)).
- Internal ID numbers
  - **Merged Plate Id:** A unique identifier for the merged plate that this press plate was placed on. In the reporting XMLs, it is mentioned as an attribute for `Plate id`. For example: `<Plate id="56c3-2ef4-0001">`.
  - **Press Plate Id:** A unique identifier for that press plate. In the reporting XMLs, it is mentioned as the element `<IdOnPlate>`. For example: `<IdOnPlate>000070518_20151210152733_process_Yellow</IdOnPlate>`. This ID was first created by the RIP when it created the LEN file and then added it to its XMP metadata as `<egPlate:plateid>`.

Learn more in [Interpreting the Reporting XML files](#) on page 1562.



**Note:** This Id had no relation to the 'Plate ID' as described in [Working with Plate ID](#) on page 1554.

## Functionality

Right-click an entry to choose any of these actions (some are only available in specific statuses):

- **Resubmit Press Plates:** This resubmits all selected entries back to the plate merger (same LEN files with same submit options). You will be asked to confirm.

This is useful when a part of a flexo plate was damaged or when your press operator requests a new plate of only that specific separation.



**Restriction:** The LEN file of the selected press plate still needs to exist (on the same folder).



**Tip:** The [Merged Plates view](#) also offers to resubmit (parts) of a merged plate.

- **Go to Job:** When the Pilot is in Container mode, use this to have the Press Plates view go to the Job mode of the Job that this press plate belongs to.
- **Go to File:** Opens the Files view and selects the LEN file of this press plate. This can be useful to check its XMP metadata (.
- **Show in Plate Merger:** Shows this item in the Plate Merger Queue (when present there).
- **Go to Merged Plate:** Opens the [Merged Plates](#) view, zooms in on the merged plate that this press plate belongs to and selects that press plate in the preview (blue line).
- **Show Related Tasks:** This open the Tasks view and shows the workflow that was used to create the merged plate and submit it to the flexo device.



- **View.** Opens the press plate's LEN file in the Automation Engine Viewer. This will require the LEN file to have prepared view data (learn more in [Working with RIP data in the AE Viewer](#)).



**Note:** If you wish to open LEN files in the DFS "View" application (aka "Esko Bitmap Viewer", Windows only), then choose 'Go to File' and double-click the file there. This will open the file in the application that you first instructed your local computer to 'open with'.

- **Group by Press Plate Set:** Use this to see the rows grouped by entries that were submitted together.
- **Group by Merged Plate:** Use this to see the rows grouped by the merged plate they ended up on.



**Note:** You cannot select and delete entries in this view. They will be removed based on the automatic clean up option in the [Plate Merger item in the Configure tool](#).

## 17.2.4. Press Plate Sets

### Concept

This view is intended for CSRs (Custom Service Representatives). It adds an overview of Job orders and the status of their required press plates in their workflow to the flexo device. This can also include the workflow of cutting the flexo plate on a Kongsberg table.

In Container mode, this view shows all press plate sets, created in a Job context or not. In Selected Job mode, it only shows those created in that selected Job.



**Tip:** Especially in Container mode, it can be useful to work with [Smart Views](#): one could focus on plate status, another on plate waste, etc.

### The Right Pane: Pie Chart and Details

Select an entry to see a graphical overview and some key information in the right pane.



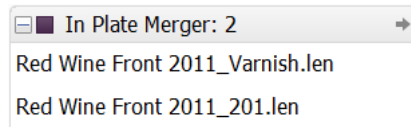

- The pie chart shows in color **how many** press plates of the selected set are in which **status**:
  - **In Plate Merger:** How many are still in the Plate Merger, waiting to be put on a merged plate.
  - **In Output Workflow:** How many were recently merged on a plate and are still in the merge queue's output workflow.
  - **Queued On CDI:** How many are part of a merged plate that is in a CDI "Exposer" queue.
  - **Exposing:** How many that are part of a merged plate that is current being exposed on the CDI.
  - **Expose Done:** How many that were exposed on the CDI but are still to be cut on the Kongsberg table (also see column "**Cut State**"). For TIFF devices, this status is already set shortly after the TIFF layout arrives in its output folder, i.e. where the workflow on Automation Engine is done.
  - **Expose Error:** How many that experienced an error during exposing on the CDI.
  - **Expose Cancelled:** How many are part of a merged plate that was cancelled when being exposed on the CDI.

- **Cut Error**: How many where an error appeared during cutting on the Kongsberg table.
- **Cut Done**: How many where the whole workflow is done successfully. These were exposed on the CTP and, if requested, also cut on the Kongsberg table.
- At the bottom of the right pane, click  to see the amount and the names of all the **Press Plates** and (if available) **Merged Plates** for this set.
- **"In Plate Merger"** shows the amount and the names of the press plates that are still in that state.



In case you wonder why they are still in the plate merger, click  or click on a specific press plate name to open the plate merger view and select them in their merge queue, where you can read details about their state.



**Tip:** Use the arrow buttons     in the Pilot tool bar to come back to this previous view.

- **"In Error"** lists the press plates of which some step in the workflow failed.

## Columns



**Note:** As in many views in the Pilot, you can

- re-arrange columns by dragging their title to a new position
- sort them by clicking on a column title
- right-click a column title and choose to **Hide** this one or any other. In the list that appears, select **Select Columns...** if you want to change or re-arrange multiple items.
- use filters and optionally save them as a *Smart View*.
- define your preferred unit in **Edit > Preferences > Units**.

Columns describing a status (see above list) show the amount of press plates of this set are in that status. The possible statuses are very similar to those [described in the Press Plates view](#).

## Functionality

- **Go to Job:** The view filters itself to the **Last Used Job** mode of the job that these press plates belong to.
- **Go to Folder:** The view switches to the **Files** view and selects the folder where the press plates' LEN files are. This is for example useful to check their XMP metadata () or to manage their prepared view files.
- **Show in Press Plates:** Opens the Press Plates view and selects all press plates of this set. This is useful to check more detail about the different press plates or to see the (internal) ID of the merged plate(s) they ended up on.

- **View:** Opens all press plate's LEN files together in the Automation Engine Viewer. This will require all LEN files to have prepared view data (learn more in [Working with RIP data in the AE Viewer](#)).

## 17.2.5. Plate Merger

### Concept

LEN files are sent to the plate merger by submitting them to a specific **Merge Queue**. Each merge queue has its own settings regarding plate type, size and merge parameters. For each merge queue, the plate merger calculates if it can merge the press plates (LEN files) in that queue onto a layout.

A plate merge queue starts to calculate possible layouts

- every time a new press plate enters the merge queue,
- every time a layout was decided, it then tries a next one,
- every time a press plate's due date is reached (or [a time based on that due date](#)),
- every time someone decides to **Force Out** one or more press plates.
- every time a merge queue setting was changed (one that is relevant for calculating layouts).

Press plates that you submit to a merge queue can be merged together on a same merged plate,

- when they have the same value for plate type, resolution, imaging technology and cutting workflow,
- and when they have the same value for custom **Grouping Keys** (that you can set up in the [Configure tool](#)).



**Attention:** The plate merger requires that the XMP metadata of the input LEN files contain information on `hsize`, `vsize` and `resolution`. This is the case for LEN files created by Imaging Engine or FlexRip version 14 or higher.

When a merge queue decides on a layout, the assigned output workflow is started. The first task in that workflow creates a LEN or TIFF file of that new [merged plate](#), the last one submits that merged plate to the chosen flexo CTP device.

### A Merge Queue Per plate Type

The best reason to have several merge queues is to have **a merge queue for each plate type**.

Also when you have more than one flexo device, we advise to let a merge queue pick a device automatically. This allows it to calculate more possible layouts, which improves the fill percentage in the decided layout. Later in the workflow, the task [Submit to Flexo Device](#) sends the merged plate LEN or TIFF file to the device that the merger created the layout for. Learn more below about [load balancing](#).

Some remarks and advice when you consider **other reasons to create different merge queues**:

- Queues that start different workflows: For example, one queue could have an output workflow including extra steps for quality control.
  - However, a workflow itself can contain tools that decide conditional behavior (routers, SmartNames, etc.), so we advise to first check if it is possible to have one merge queue launching a workflow that includes different steps depending on the file's or its Job parameters.
- Queues that are not different in their queue settings but have differences in the way their output will be imaged (CDI parameters): For example, a merge queue that only handles exposure of 2540 ppi or Pixel+ press plates.

- However, it is better to submit all these files to one same merge queue and use grouping keys to control the files they are merged with.

Important parameters like resolution and imaging technology are grouping keys that the system itself already uses automatically.

Learn about adding custom grouping keys in [Submit to Plate Merger task](#) on page 1544.

### Working with Partial Plates

When you want to use partial plates with fixed sizes, you can use the automatic workflow. Those sizes are then predefined in a merge queue. Mind that Automation engine is not keeping track of the offcuts.

When you want to use partial plates with variable sizes, we advise to use the DFS Merger in Automation Engine mode and create a layout for that unique size. Learn more about this workflow in [Using the DFS Merger in AE mode](#).

### Adding Test Strips or Margins to the Merged Plate

The Plate Merger can also add [test strips](#) or [margins](#) (frames) to the merged plates. This is done via a set of rules that you can set up in the [Plate Merger Configuration](#). These rules are valid for all merge queues.

### Adding a Merge Queue

Follow these steps to add a new merge queue:

1. In the Plate Merger view, click the  icon (at the bottom) and choose **New Merge Queue** (or use the **File** menu).



**Note:** To create a merge queue similar to another one, select one and choose **Duplicate**.

2. Add a **Name** (or use the one that appears in the next step).
3. In **Plate Type**, click on  to see a list of all available types (on the configured CDI devices). Select a plate type.
4. In **Merge for**, define for which sizes this queue needs to calculate layouts. This is decided by the **Device, Drum** and **Size** fields.

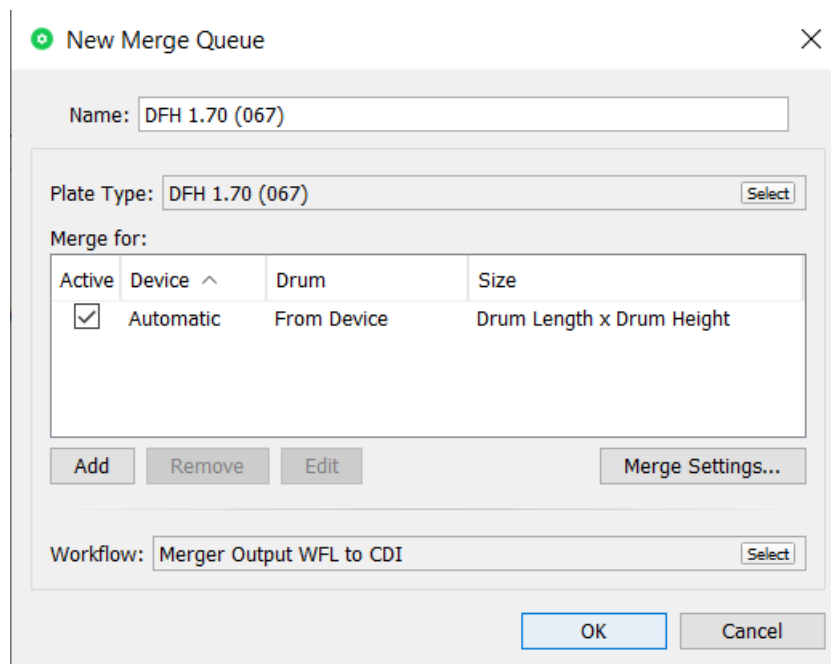

- **Active:** In this column, select or deselect the device that the merger can make layouts for. Learn more below about adding extra devices to merge for.
- **Device: Automatic** is the default setting. The merger then checks all available flexo devices and drum sizes to calculate which one offers the best fill percentage. In case the fill percentage is very similar for multiple devices, the merger chooses the device with the lowest queue load (see the [estimated time in its device status box](#)).
- **Add** or **Remove** extra devices. Some example cases to add specific devices:
  - You have two or more CDIs of a different size and you use a plate type that is not available for all of those. You could then make a merge queue for that plate type that only merges for the CDIs where it can be used on.
  - You can add all your devices and de-activate the one that you know will become (temporarily) unavailable. Mind that the merger automatically detects when a CDI is not online. However de-activating a device it here may be useful to prevent that more jobs go to its expose queue. For example when you know that, in a few hours, that CTP device will be offline for an intervention or maintenance.
- **Drum.** When you added a specific CDI in this list, the merger is automatically aware of what drum is present when calculating a layout. A example situation to still add a specific drum in this list, would be when you plan on changing the drum in the near future. That way, you can have a merge queue that already makes layouts for the new drum size.  
 To specify a drum, double click a device / row, and in **Edit Size Options**, click on  in **Drum Name** and select it from the list.
- **Size.** By default, the **Drum Length and Drum Height** will be used (as configured on the CDI). If you want a smaller size, type it in (for example for partial plates with a recurring size).

When a  warning sign appears next to the name of the device, hover your cursor over the icon to read its meaning. It may be that the plate type for that queue is not recognized.

5. Merge Settings...

Merge Settings
✕

Minimum Fill:

Override Minimum Fill:  hours  minutes before due date

Press plates will be merged once the minimum fill percentage is reached. If the minimum fill percentage is not reached at the specified time before the due date, the press plates will be merged anyway.

---

Rotation:

Auto-place Mode:

Maximum Calculation Time:  seconds

---

Cut Marks:

Press Plate Margins:

Press plate margins will be extended to 4 mm on the merged plate as soon as it contains a press plate for which a text label was specified.

---

Solvent Saver:

Solvent Saver Margin:

Solvent Saver Fill:

Maximum Grid Cell Width:

Maximum Grid Cell Height:

Grid Cell Gap:

- **Minimum Fill:** Define the minimum fill for a merged plate.



**Tip:** Based on your workflow and production needs, you will need to find a balance between optimal plate usage and urgency of exposing the plates. Especially when your merge queues often contain press plates of variable sizes, it may be beneficial to wait until some (more) small ones are submitted to help fill the flexo plate (and so reduce plate waste).

- **Override Minimum Fill:** <time> before the **due date**. Use this option to ensure that you make the flexo plates by their due date (the time specified in the [Submit to Plate Merger task](#)). When you need to ship the press plates by 5 PM, you could for example make sure that they are merged by 3 PM, so leaving enough time for exposing, post-processing, cutting and packing.
- **Rotation:** Define if you allow the merger to rotate the press plate 90 degrees on the layout.
- **Auto-place Mode:** Choose the main mode that this merge queue should base its calculation on:
  - **Area Optimized:** Layouts with the largest plate fill percentage.

- **Cut Optimized:** Layouts that are optimized for manual cutting. Press plates will be placed in 'lanes' as much as possible, so enabling longer straight lines that are easy to cut manually.
- **Maximum Calculation Time:** *Each time a calculation is triggered*, this is the maximum time that the merge queue is allowed to spend on calculating a layout. When that calculation results in a layout, the merge queue then continues and tries again for that same period, now to make another layout with the remaining press plates. This continues until the merge queue can create no more layouts (with its current settings).

This time is spent on each calculation for each device this merge queue is asked to calculate for (30 seconds then means 30 seconds for each device).

When you have many press plates, increasing this time can help to create layouts with a higher fill percentage.



**Tip:** The default time is visible when you create a new merge queue.

- **Cut Marks:** Choose whether you want to add cut marks around each press plate (CDI or TIFF device). These marks are identical to those offered in the DFS Merger.



**Note:** In the DFS-style preview of a merged plate, these marks and lines are visible as (small) green objects.

- **None.**
- **Cutting Marks:** Small marks indicating the corners. The marks will be as long as the width of the **Press Plate Margins** (with a maximum length of 5 mm). An example:



- **Solid Cutting Lines:** Cutting lines around the press plates.
- **Dotted Cutting Lines:** Dotted cutting lines around the press plates.
- **Press Plate Margins:** You can add an extra empty area around each merged plate. This is also where the cut marks are placed.



**Note:** When you here add 10 mm, the space between 2 press plates will be 20 mm.



**Note:** When you add **Cut Marks**, 1 mm of press plate margins will be added automatically. When you *requested to add a text label to the press plate*, a 4 mm margin will be added to the side where the label needs to appear (unless there was already a larger margin).

- **Solvent Saver:** Choose if you wish to activate the solvent saver technology. Learn more in [Working with Solvent Saver](#) on page 1561.
  - **No:** The system will leave the waste area around the merged contents as is.
  - **Yes:** The system will add 100% (black) areas in the waste area around the merged contents, so that when exposing the plate the waste area also gets exposed to UV. As a consequence the top layer of this waste area will not be washed away by solvent in the washer/plate processor which leads to a reduction in solvent waste or solvent saving. Using this option has no effect on the available merge area.



**Note:** These extra 100% black areas will be ignored when generating the cutting file for the merged plate afterwards.

- **Solvent Saver Margin:** When you choose **Yes**, you can here specify the amount of space that the system should keep between the black solvent saver areas and the actual merged contents (press plates). The default and minimal value is 4 mm.
- **Solvent Saver Fill**
  - **Solid**
  - **Grid Pattern:** When merging for thick (corrugated) flexo plates, completely filling up the waste area as one big solid could later on trigger unwanted plate curling when being processed by the dryer. Applying a grid pattern instead of a solid area prevents this unwanted behaviour, but also means that less solvent will be saved..
    - **Maximum Grid Cell Width and Height.**
    - **Grid Cell Gap:** Specify the gap that should be kept horizontally and vertically in between the different cells when applying the grid pattern.

An example:



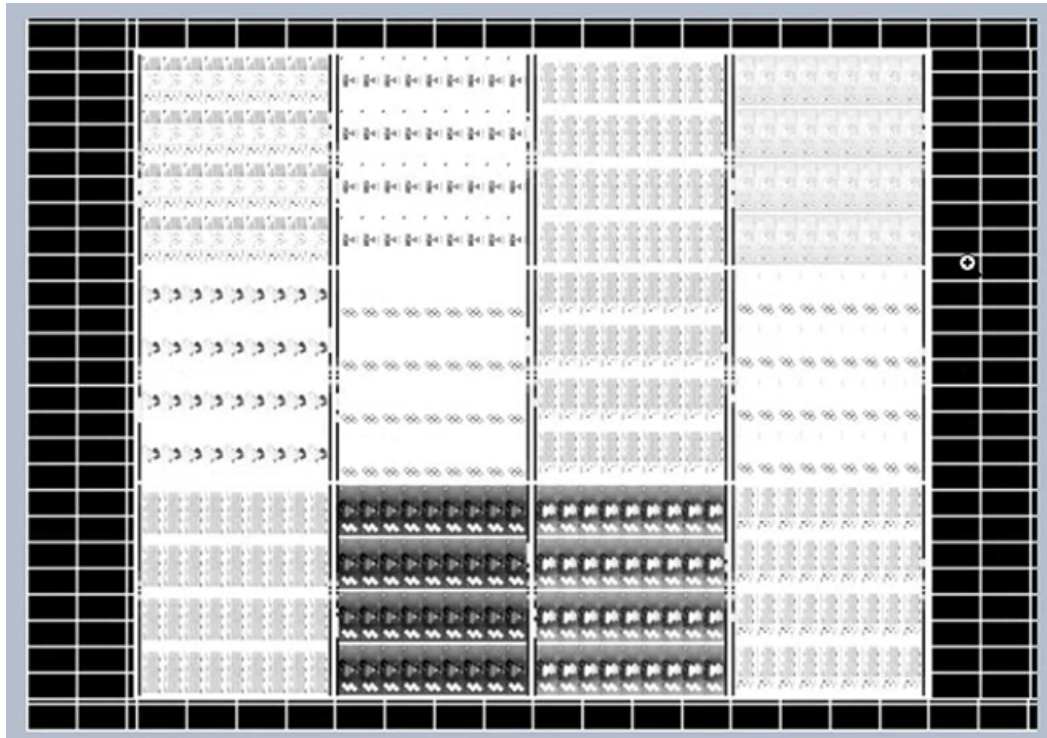

6. **Workflow:** Select the output workflow for this merge queue. As mentioned in [the introduction](#), this workflow needs to start with the [Create Merged Plate task](#) and end with the [Submit to Flexo Device task](#). Only global workflow tickets are possible.



**Attention:** In theory you can extend this workflow with other task steps but then make sure you still respect the required task input files in this workflow:

- The layout that the merger calculates is an XML file. This first step of this workflow, the task Create Merged Plate, needs that file as its input file.
- The output file of the task Create Merged Plate (also an XML file) needs to be the input file for the task Submit to Flexo Device.



**Note:** When the selected workflow is launched for the first time, a predefined set of workflow parameters will be injected in this workflow and can so be used by the steps in this workflow. The values of these workflow parameters will set every time the workflow runs,

- `cdi.drum`: Name of the drum of the CDI as defined in the Expose application on the Grapholas PC. Not available for TIFF devices.
- `cdi.id`: Internal id how the CDI or TIFF device is configured within the Automation Engine server.
- `cdi.name`: Name of the CDI or TIFF device as configured in the Devices View.
- `CutWF`: Name of the cutting workflow used in the Submit to Plate Merger task.
- `ImgTechn`: Imaging technology set in the Submit to Plate Merger task.
- `mq.mergerxml`: URL of the input file of the workflow.
- `mp.type`: Plate Type as configured in the Merge queue.
- `mq.name`: Name of the Merge Queue.
- `PlateType`: Plate Type as configured in the Merge queue.
- `Resolution`: Resolution of the Merged Plate.
- User defined name of the grouping keys as defined in **Configure > Plate Merger > Name Custom Field**.

7. Click **OK** to confirm and create the merge queue.





**Note:** You can also select an existing merge queue, right-click or click  and choose **Duplicate** to create a similar queue.

## Managing Merge Queues

### Pausing a Merge Queue



**Attention:** When your setup is a standalone **Device Manager** (i.e. not a full Automation Engine), the merge queues will always be paused. You will also not be able to Hold or Release items in these queues. Contact Esko to learn how to extend this functionality.

Select a merge queue, right-click or click  and choose **Pause Merge Queue** to stop a merge queue from trying to create layouts. The icon of the queue then changes to . Press plates can still be added or removed, but no automatic merging will take place.

Choose **Resume Merge Queue** to activate the queue again (.

Pausing a merge queue is interesting in these cases:

- When, during busy production, you want to change some settings of that merge queue.
- When you are used to work with [layout proposals](#), you sometimes want to pause the queue while investigating the proposals.

- When you use the [DFS Merger in Automation Engine mode](#), the DFS will automatically pause the merge queue that you selected there.



**Tip:** There is no need to pause a merge queue because a CDI is down or offline. The merger automatically detects this device status and will resume merging for that device as soon as the CDI is available again.

### Viewing and Managing Queue Entries (Press Plates)

To define which columns you wish to see, go to **View > Select Columns in ...** or right-click on a column header and (de)select the type. You can also drag columns to a different position.

Select an entry to see a panel with information on the press plate (LEN file), including its submit date and due date.

The plate merger works fully automatic but there are some manual interventions you can still do on selected press plates:

- Click or right-click and choose **Hold** to prevent the merger from considering these entries.
- Click or right-click and choose **Release** to release these entries that were put on hold.
- Click or right-click and choose **Force Out** to force the merger to create a layout instantly including the press plate(s) you forced out. In this case, the queue's setting [Minimum Fill](#) is ignored. The merger also tries to add other press plates to that layout (that were not forced out but were in 'waiting' status).

The merger creates as many layouts as needed for all the forced out entries and then falls back on its usual calculation schedule.

- Click or right-click and choose **Delete** to remove the press plate from this merge queue.
- Click or right-click and choose **Info** to see the XMP metadata of the press plate's LEN file.



**Tip:** The dedicated view [Press Plates](#) offers more information and functionality on press plates.

- Right-click an entry and choose **Go to File** to open the **Files** view and see the related LEN file selected in its (Job) folder.

An entry in a merge queue can have these statuses:

- **Waiting** for the merger to be placed on a layout.
- **On Hold**, not available for the merger until released again.
- **Forced Out**. The queue entries that you forced out are still available in the queue with this status until they disappear a few moments later (once the merger finished calculating which other 'waiting' entries could also be put on the layout).
- **Rejected**. Hover your mouse over the icon to read details. When a press plate remains stuck in a merge queue, it most probably rejected by all targeted devices because of one or several of these reasons:
  - The press plate is too big for the device.
  - The press plate's resolution is not available on the device.
  - The press plate's imaging technology is not available on the device.
  - The press plate's imaging technology is not available for the plate type on the device.
  - The press plate contains HD screens and the device does not have an HD Flexo license.
  - There are no devices available to merge for.

- The plate merger's output folder is low on disk space.
- The selected cutting flow file does not exist anymore.
- There is an unsupported drum installed. Sleeve and pre-mount drums are not supported.
- The reason is unknown.

In some of the above cases, the reason for rejecting the item can disappear. For example: When a CDI that was off-line becomes available again, the merger automatically detects this. So the next time the merger calculates possible layouts, the items that were intended for (only) that device will again change their status from 'rejected' to 'waiting'.

### About Load Balancing

As mentioned above, when you allow a merge queue to create a layout for more than one CDI ("*Device: Automatic*"), then, if the plate fill percentage is very similar, the merger will choose to create the layout for the device with the least work to do (based on the estimated time mentioned in the *device's status box*).

This load balancing is not available for TIFF devices. When it has to choose between TIFF devices there is currently no way to predict which one the system will choose.





**Note:** If the automatic merger has to choose between a CDI and a TIFF device (in a case where they already have a similar waste percentage), it will choose the CDI device.

### When the due date is more important than waste reduction

The plate merger's focus is on making layouts with the least waste. When submitting press plates, you can also define a due date.

Follow these steps to make layout and output decisions (also) based on this due date:

1. In Plate Merger view, select a merge queue and select all entries in that queue.
2. Click  to put them all on hold.
3. Sort the list on due date by clicking on the header of the column "**Due Date**".
4. Select those that, for example, must be delivered within the next 3 hours.
5. Click  to release these entries.
6. Optionally, go see the *layout proposals* of this queue (unless the queue's already decided on a layout and created merged plates).

### Managing the Merger's Output Files

The plate merger creates many files in the folder that was defined in the *Plate Merger item in the Configure tool*. You can there also define when these data should be cleaned up.

### Plate Merger Configuration



**Note:** Learn about the Plate Merger concept and View in the chapter *Flexo CTP Device Workflow* on page 1482.

To configure your plate merger, go to **Pilot > Tools > Configure > Plate Merger**.

- *Tab 'Setup'* on page 1511
- *Tab 'Reporting'* on page 1512

- [Tab 'Test Strips'](#) on page 1515
- [Tab 'Margins'](#) on page 1518.

**Tab 'Setup'**

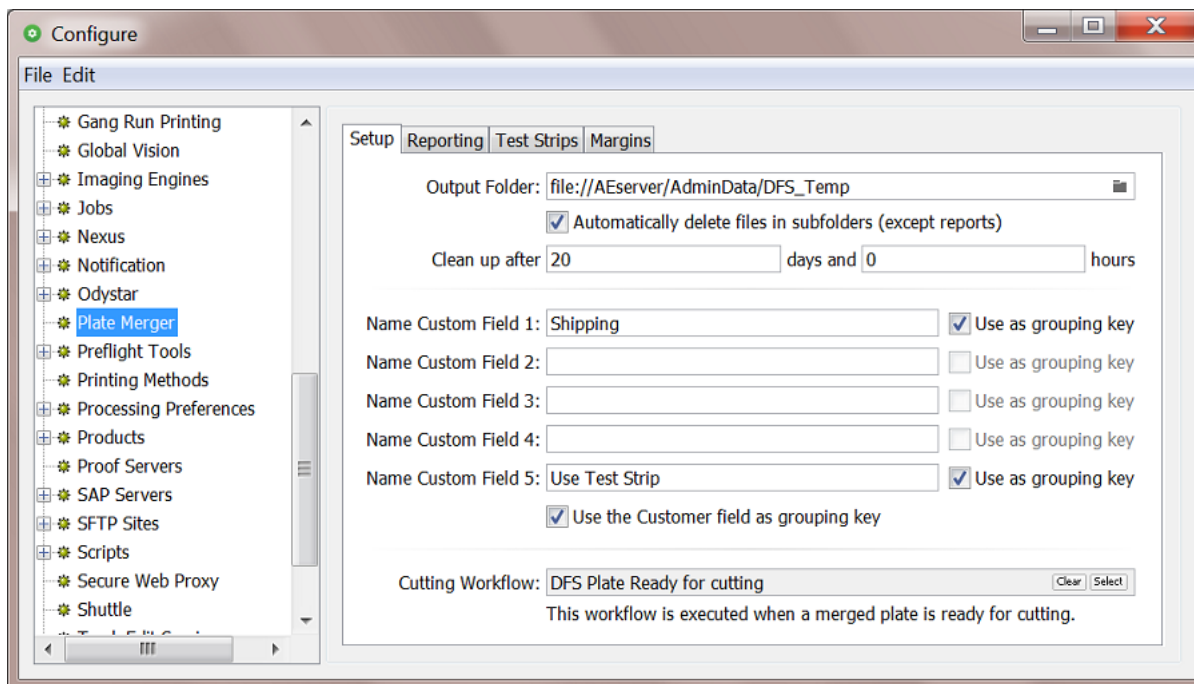

- **Output Folder:** This folder stores files created by the plate merger, in many subfolders. These are the files you see when, in the [Merged Plates view](#), you use the feature **Open in Browser**.

The large LEN files that were created by the [Create Merged Plate task](#) also resides here. In case of CDIs, their DFS Exposer application downloads them from this folder when he starts exposing. For TIFF devices, the large layout TIFF file has its own output folder.



**Attention:** Do not manually manage any of the files in this folder or its subfolders.

Click  to change the default path to a custom one.



**Attention:** When changing this folder, make sure there are no more files in there that are used by the merger.

- When you select **Automatically delete files in subfolders (except reports)**, then define in **Clean up after** after which time you want all these temporary files to be deleted (merged plate LEN file, GIFs, XMLs, etc.).



**Attention:** A merged plate cannot be [resubmitted](#) to be exposed again when its related files in these folders have already been deleted.

- **Name Custom Field 1 - 5.** Many of the Flexo Device related views show columns. If you want to use any of these 5 custom columns, enter their name here. The value of custom fields can be set in the [Submit to Plate Merger task](#).

- Select **Use as grouping key** if you also want to use that custom field as a grouping key in the plate merger's merge queue. Grouping keys limit the plate merger's freedom to decide which press plates can be considered to be placed on a same merged plate.
- Select **Use the Customer field as grouping key** if you want to avoid that press plates from different customers (when specified) are placed on a same merged plate.
- **Cutting Workflow.**

When a merged plate was exposed on a CTP that will be cut on a cutting table, the here selected workflow will automatically be started.

This workflow is launched on the XML that contains the cutting information that was originally defined in the [Submit to Plate Merger task](#).

- When you use a Kongsberg table, the workflow needs to submit that XML file using the [Submit to Kongsberg Table task](#).
- When your cutting table is not a Kongsberg, you need to create a workflow that selects the cutting instruction file itself and then forwards that file to the cutting table. This can be done by using the [Select Referenced file task](#). An example:



Learn more about cutting flexo plates on a Kongsberg table in the chapter [Kongsberg Production Workflow](#) on page 1565.

**Tab 'Reporting'**

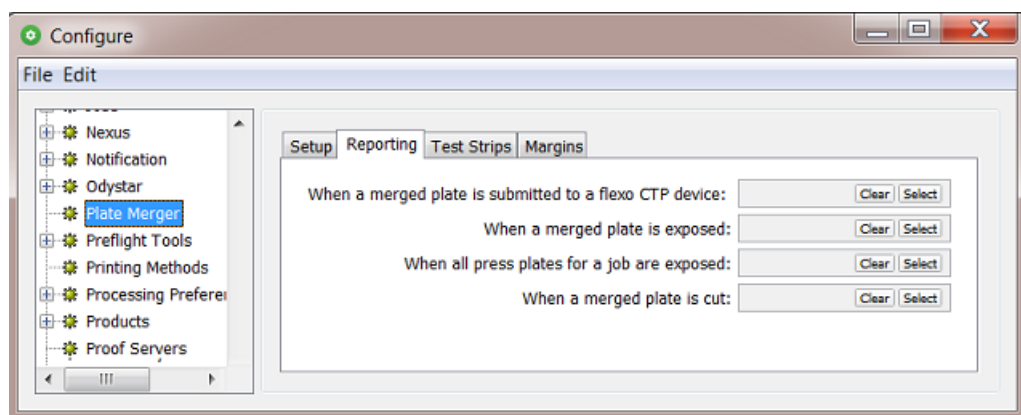

These 4 fields allow to automatically launch a workflow at those specific moments. These workflows serve to send feedback to external systems, to inform them on statuses or deliver information that helps cost calculation.



**Note:** In stead of waiting for workflows to send this information, an external system can also get such information on demand. Learn more in [External Systems Requesting Information](#) on page 1513.

The input file for these workflows is decided automatically. These input files are XML report files containing specific information that is valid at that time.



**Note:** These XML report files are picked up from a subfolder 'Reports' of the **Output Folder** defined in the tab 'Setup'. These files are not deleted by the cleanup tool in that panel. You could choose to have the workflow that you launch on them also delete them at the end (or after a few months for example).

- **When a merged plate is submitted on a flexo device :** This is each time a [Submit to Flexo Device task](#) sends a merged plate to a CDI "Exposer" queue or writes a TIFF in the output folder for a TIFF device. This report is also available as a link in the task details of such a [Submit to Flexo Device task](#).
- **When a merged plate is exposed:** Each time a merged plate is exposed, this XML can deliver information about the device, plate usage, waste, etc. This workflow is also launched when the merged plate was cancelled (removed from the CDI's expose queue). In case of a TIFF device, the state 'exposed' is already set right after the TIFF arrived in the output folder.
- **When all press plates for a job are exposed:** When all plates of a [press plate set](#) are exposed (or cancelled), this XML can inform on which job, which plates, when, plate usage, etc. This XML can for example describe the plate usage by the job's 5 press plates that ended up on 3 different merged plates.
- **When a merged plate is cut:** Learn [here](#) how and when the CDI workflow communicates plate cutting instructions to a Kongsberg cutting table (iPC). The workflow that you define here will be launched each time such a flexo plate was cut. This signal to launch a workflow can also be the case when the plate was exposed on a TIFF device and later cut on a Kongsberg table.

Learn more about these XMLs in [Interpreting the Reporting XML files](#) on page 1562.

The most simple workflow to launch on those XML files could be a "Copy or Move File" task to make that XML file available to another system. Here is an example of a more advanced workflow to feedback such events to a business system:



**Note:** Learn more about delivering information to external systems in [this dedicated chapter](#).

## External Systems Requesting Information

### Concept

External systems (MIS, ERP, ...) are especially interested in how much flexo plate was used for a job. They use this information to help decide the cost for that job. In stead of waiting for workflows to send them this information, external systems can also get this and other information on demand. Some want to see what is still waiting in the merge queues. Some want to see the overall status of the CDI device(s).

### 1. Requesting info on how much plate was used for a job (cost, statistics)

An external system can do HTTP calls to request status information of **all Press Plates** of a specific **Job**. To do this, the external system needs to execute an HTTP 'GET' request. It will get an XML file as a result.

**Syntax:**



**Tip:** As a test, you can also execute HTTP requests via a browser.

- **Input:**

Syntax of the URL to HTTP-GET the XML report:

`http://<name-of-AE-server>:4412/FPL/job/<jobname>`

- `<name-of-AE-server>` = the name of the Automation Engine server (the master server).
- `<jobname>` = the **Job Name** of the job of which you want the XML report.

Example: `http://<name-of-AE-server>:4412/FPL/job/1234banana`



**Note:** To get an XML where the list of **Press Plates** are listed per **Press Plate Set**, add the parameter 'groupperset=1'. The "Images" (Press Plates) within the XML element 'Images' will then be grouped per 'ImageSet'.

Example: `http://<name-of-AE-server>:4412/FPL/job/1234banana?groupperset=1`

- **Output:**

An XML report describing all Press Plates related to that Job, including their current status.

### 2. Requesting info on what is still waiting in the merge queues (job load)

The amount of press plates that are still in merge queues also predict the work load for the next hours.

**Syntax:**

- Go to `http://<name-of-AE-server>:4412/FPL` to see an information page.
- There, in the topic **Live PlateMerger queue Updates(/MQ)**, click the link to see the 'Server Sent Events'. The 'Server Sent Event' source can be reached at `http://<name-of-AE-server>:4412/MQ/SSE`. An example:



The screenshot shows a web browser window with the title 'PlateMerger-queues-SSE'. The address bar contains 'eaw16dl271:4412/INFO/mqsse1.html'. The main content area is titled 'Live PlateMerger queue status updates' and contains a table and an event log.

MergeQueue	State	Paused	Queue-Length	Finished
DFH 1.14 (045)	idle	paused	4	
DFH 1.70 (067)	idle	active	0	
Lintec 124	idle	paused	0	
Next Generation Laserpoint II	idle	paused	0	
Round Classic	idle	paused	0	
WS 0.73 (029)	idle	active	0	

**Event Log**

Received:  
 13:30:12 [{"IDLE":"TRUE","QUEUELENGTH":4,"PAUSED":"TRUE","NAME":"DFH 1.14 (045)"}, {"IDLE":"TRUE","QUEUELENGTH":0,"PAUSED":"FALSE","NAME":"DFH 1.70 (067)"}, {"IDLE":"TRUE","QUEUELENGTH":0,"PAUSED":"TRUE","NAME":"Lintec 124"}, {"IDLE":"TRUE","QUEUELENGTH":0,"PAUSED":"TRUE","NAME":"Next Generation Laserpoint II"}, {"IDLE":"TRUE","QUEUELENGTH":0,"PAUSED":"TRUE","NAME":"Round Classic"}, {"IDLE":"TRUE","QUEUELENGTH":0,"PAUSED":"FALSE","NAME":"WS 0.73 (029)"}]  
 13:30:02 [{"IDLE":"TRUE","QUEUELENGTH":4,"PAUSED":"TRUE","NAME":"DFH 1.14 (045)"}]

Per Merge Queue, the following information is returned:

- NAME : Name of the merge queue
- IDLE : "TRUE" when the merge queue is not merging/calculating proposals
- IDLE : "FALSE" when the merge queue is merging/calculating
- PAUSED : "TRUE" when the merge queue is put on hold
- PAUSED : "FALSE" when the merge queue is active
- QUEUELENGTH : Number of entries currently in that merge queue.

### 3. Requesting info from the CDI device

HTTP calls can also be used to retrieve information about the CDI **Device** status. This enables to show what you see in the CDI Device view in your own custom dashboard.

Learn more in [CDI Device Status in an External Dashboard](#) on page 1491.

## Tab 'Test Strips'

### Concept

You can here define which test strips that the plate merger needs to add to the layouts it makes. These test strips are LEN files that you created earlier.



**Note:** LEN files can be used as test strip when they have sufficient XMP data. When your LEN files are made by FlexRip 7 or older, contact Esko support for help.



**Note:** Also when the merged plate will be a TIFF file, the test strip needs to be a LEN file.

You also set up rules that define when which test strip needs to be added. These rules are valid for all merge queues.

A test strip's position and orientation on the layout can not be predicted. An example of where it could be placed:



**Note:** When calculating layouts, the plate merger first puts the test strip on the trial layout and then checks how to fill the remaining area. The surface of a test strip is also calculated when calculating the required fill percentage.



**Attention:** On a merged plate, test strips are not counted as press plates (which together represent the used plate area). This means that adding test strips increases the waste area of a merged plate.

### How to Add a Test Strip Rule

Setup | Reporting | Test Strips | Margins

Registered Test Strips:

File Name	Size	Resolution	Submit Date	Folder
2400 Polymer wedge Ko...	350.074 x ...	2,400 ppi	2/23/17 4:...	file://egsbe...
TestStrip_Default_2000...	320.865 x ...	2,000 ppi	2/10/17 12:...	file://home...
TestStrip_Default_2400...	320.855 x ...	2,400 ppi	2/10/17 12:...	file://home...
TestStrip_Default_2540...	320.86 x 2...	2,540 ppi	2/10/17 12:...	file://home...

Details

File Name: TestStrip\_Default\_2000ppi....

Submit Date: 2/10/17 12:28 PM

Size: 320.865 x 25.514 mm

Resolution: 2,000 ppi

Add Remove

Define rules to add a test strip to a merged plate:

Active	Name	Test Strip
<input checked="" type="checkbox"/>	Default rule for 2000 ppi	TestStrip_Default_2000ppi.len
<input checked="" type="checkbox"/>	Default rule for 2540 ppi	TestStrip_Default_2540ppi.len

Add Remove Edit Move Up Move Down

The first matching rule will add the corresponding test strip to a merged plate.

1. First register the test strip file. In **Registered Test Strips**, click **Add**, browse and select the LEN file. The system will create a thumbnail and show you its **Details**.
2. Then define a rule when this test strip should be used. In '**Define rules ...**', click **Add** and **Name** this rule.
3. Set the **Conditions** that need to apply for this test strip to be placed on the layout.

The most typical condition for such a rule is to add a test strip with the same resolution as the other press plates on the layout. Other conditions usually are imaging technology, plate type or adding them customer specific.



**Note:** Creating these rules is very similar to creating filters in the Pilot. Learn more [here](#).

See this example where one of the *custom fields* (that is also used as grouping key) helps to decide if this merged plate needs a test strip or not:

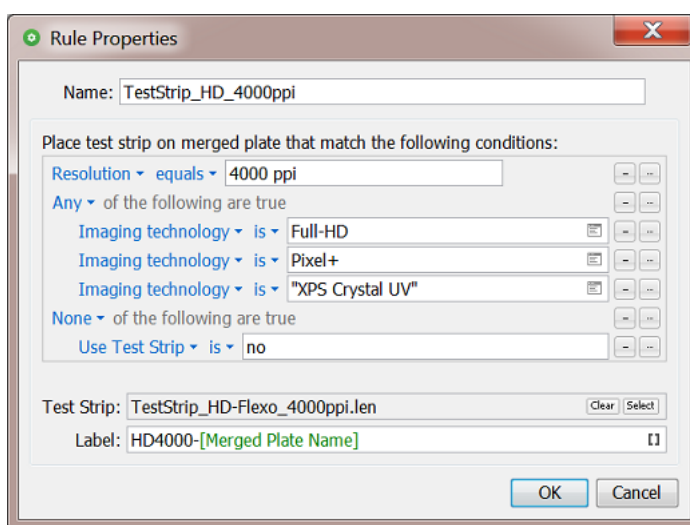

4. **Select** the LEN file for this rule (from the list of the ones you registered earlier).
5. Optionally, add a **Label** to this test strip. This text will appear along its long side. A margin is created automatically (on the side of the test strip where the label is added).



**Tip:** It may be useful to add the plate name as a label above the test strip. This way, after cutting, you can still find back which strip was used for which press plates. For example, when you want to check a complaint on a certain press plate, then follow these steps to find the test strip that was also on that same flexo plate:

1. In the Press Plates view, look up the press plate entry (filter via via job, orderid, id on Plate, file name, etc.)
2. Right-click this entry and choose **Go to Merged Plate**.
3. Write down the **Name** of this merged plate. It is mentioned top right and has an extension `.par`.
4. Use this name to find the test strip in the (physical) archive of your used test strips.

6. Click **OK**.
7. Click **Move Up / Down** to define the order in which multiple rules need to be executed. Put specific ones at the top and general ones at the bottom.
8. (De-)select the toggle next to a rule to (temporarily) de-**Activate** that rule.

- Use **File > Save** to save your settings. These rules are then instantly picked up by all plate merger queues.

## Tab 'Margins'

### Concept

This tab allows to add extra margins around merged plates created by the *Plate Merger*. You can add different margins per top, bottom, left and right side.



**Note:** DFS applications refer to these margins as 'Frames'.

### Rules

You can define these margins through a list of rules. Each rule can add margins for a specific combination of a device and a drum size.

The first rule that matches will be used by the plate merger and no further rules will be checked.

Use the **Add Up / Down** buttons to define the order in which the rules should be checked.



**Tip:** A last rule could be one for **Any Device, Any Drum** and **Any Merge Queue**. The plate merger will use this one for all situations that were not specified in any rule set above.

Configure

File Edit

Locations  
Notification  
Passwords  
Plate Merger  
Printing Methods  
Processing Preferences  
Products  
SFTP Sites  
Track Edit Session  
Viewer  
WebCenter Sites

Setup Reporting Test Strips Margins

Margins of the first matching rule will be applied to the layout:

Device	Drum	Merge Queue	Margin
Any Device	Any Drum	DFH 1.14 (045) - CCC	5, 5, 5, 20 mm (exposed)
Any Device	Any Drum	Any Merge Queue	10, 10, 10, 10 mm

Add Remove Edit Move Up Move Down

## Defining a Rule to Add Margins

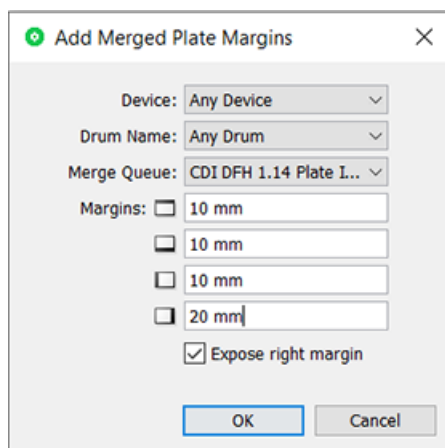

- **Device:** Set this rule for any device or select a specific one.
- **Drum Name:** Set this rule for any drum or select a specific one.
- **Merge Queue:** Set this rule for any merge queue or select a specific one.
- **Margins:** Type the wanted margins.

About their orientation: The top, bottom, left and right sides match to the orientation that is shown when viewing the merged plate as shown in these places:

- in the DFS application "Exposer", in the **Info** dialog of that queue
- in the Pilot's [Merged Plates view](#),
  - in the preview dialog that opens when you select an entry, right-click and choose **Open Preview**
  - in the previews that, when you select an entry, are shown in the right side panes.
- **Expose right margin:** When enabled, this adds a right margin that will be exposed as a solid area (by default 20 mm). This option is used by users of CrystalCleanConnect, an automated platemaking device.

An error will occur when enabling this option on a plate that is not its full size.

## Working with Layout Proposals

### Concept

When a merge queue has decided on a layout, the output workflow creates a merged plate.

However, there are several cases when you might want to see which **Layout Proposals** this merge queue has calculated but rejects as a final merged plate because they are not fully conform to the queue's [Merge Settings](#) (the required minimum fill %).

In the view **Plate Merger**, right-click any merge queue and choose **Show Layout Proposals** (or use **Alt/CMD-Down**) to open [a view that shows the layout proposals](#). You can there choose which one you want to 'force' **Expose**. You can even [edit a layout proposal](#) before exposing it.

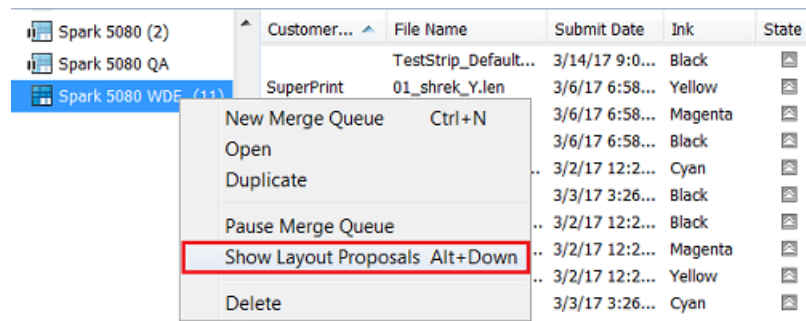

These are typical cases where you may want to see and or change these layout proposals:

- Why is this press plate still pending in the merge queue?**

You typically have double-checked the settings of the merge queue, but you still wonder why the workflow does not continue.
- I want to understand in detail how this merge queue decides a merged plate.**

Looking at the (rejected) layout proposals helps to understand how the settings of this merge queue affect the layout calculations it makes.
- As a CTP operator, I want to see all layout proposals for a specific device, so I can choose which merged plate to expose next on this device before its queue runs empty.**

Even in a workflow where you expect the best layout proposal to be chosen automatically, a CTP operator might still want a moment of visual control over which proposal should become the merged plate.
- I want a visual overview of layout proposals based on their urgency.**

Sometimes, the urgency of a plate is more important than its waste percentage and you manually want to decide this priority.
- I want to manually inspect or optimize the laser beam count of a layout.**

Sometimes you can manually optimize the speed in which a plate will be exposed by re-arranging press plates on the layout.

### Inspecting and Exposing Layout Proposals

This view shows the layout proposals of one or all merge queues. You can inspect them. You can choose to expose a selected one. You can not delete a layout proposal. The next page explains how you can [view a layout in detail and possibly make changes](#) before exposing it.



**Attention:** This view does not show *all* possible layouts ; there could easily be millions of combinations. It only shows the *best* proposals, the ones with the least waste.

The top bar in this view is in a light yellow color. This can help remind you that you are looking at proposals, not at Merged Plates.

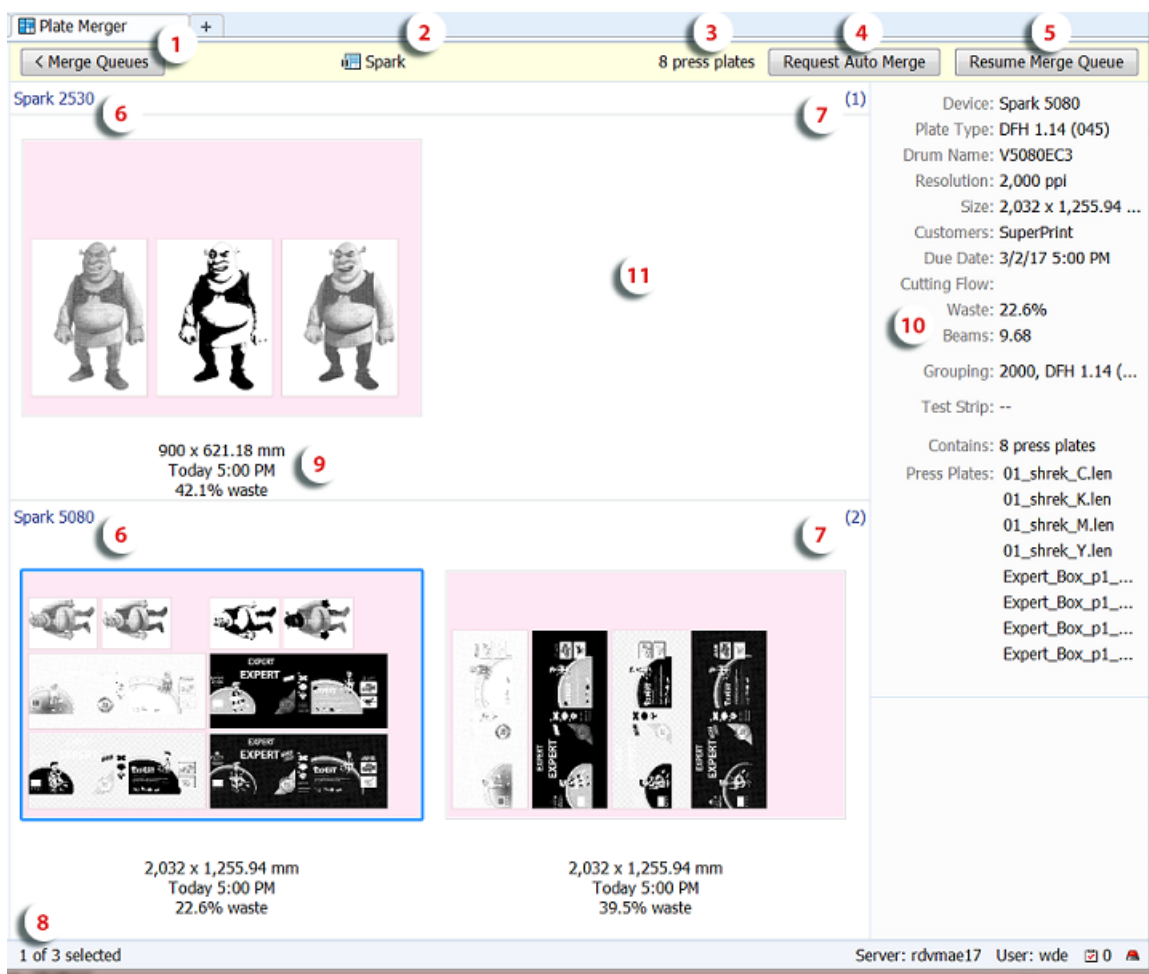

1. Click **< Merge Queues** (or use ALT/CMD-Up) to leave this view and go back to the list of press plates of this merge queue.



**Note:** To avoid navigating back and forth, create an extra **Tab** to view both modes (**File > New Tab**).

2. Name of the selected merge queue. The icon indicates if the queue is active or paused.
  - Double-click it to open the queue's settings.
  - Right-click it to select a different merge queue. This avoids having to navigate away from this view. You can also select this view for **All Merge Queues**.
3. This number shows the amount of press plates in this merge queue (no matter what state they are in).
4. Click **'Request Auto Merge'** to manually trigger the merger to (re-)calculate layout proposals.



**Tip:** When new press plates are submitted when the merge queue is paused, this view will not change. You can then click this button to trigger a new calculation of proposals.



**Note:** While the merger calculates, this button changes to **'Cancel Auto Merge'**.



**Tip:** When, after a short while, you still do not see any change in the proposals, go see the list of entries for this merge queue and check any error message(s) in their details pane. They could show that entries are "too big" or request "unsupported imaging technology".

5. **Resume Merge Queue** or **Pause Merge Queue:** A shortcut to pause or resume this merge queue (without leaving this view).
6. Layout proposals can be shown in several ways.

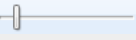

**Tip:** Use the  slider in the Pilot's top bar to change their display size.



**Tip:** Use the arrow buttons to navigate through the proposals.

Right-click anywhere in the overview area and choose from:

- **"Arrange by"**
  - by **Device** (as in above screenshot): Grouped per device. These are the devices that are listed in the settings of the Merge Queue, in "[Merge For](#)".
  - by **Size**: Grouped by size of the layout.
  - by **None**: This shows all of them, now no longer in one horizontal list but in a continuous display using any rows below.
- **"Sort by"**: Choose which layout is shown *first*:
  - **Waste**: The one with the smallest waste percentage.
  - **Due Date**: The most urgent one.
- **"Organize by Layout"**. Identical layouts are then shown in stacks that you can browse through. This is especially useful when you have multiple flexo devices that are using the same plate size. You then also typically arrange the view by plate **Size**.





**Note:** An example: You have two CDI Spark 5080 devices that use plates with the same size. You asked to calculate layouts for both devices. You switched on '**Organize by Layout**' and '**Arrange by None**':

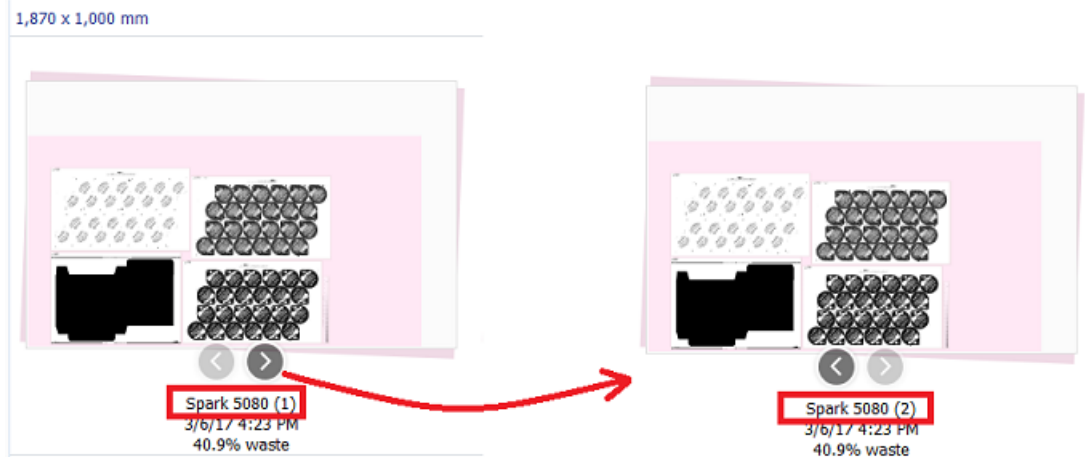

When you click on the arrows beneath the stacked layout, a next layout in this stack is shown. This other layout however will typically look identical. This is because the layouts in a stack have the same layout of the same press plates.

What typically does change in a stack of layouts is the name of the device: these are identical layouts made for more than device.

7. The amount of layouts (or layout stacks) shown in this arrangement (device/size).
8. The total amount of layouts (or layout stacks) shown for this merge queue.
9.
  - Device name (when not viewing '**Arrange by Device**').
  - Layout size (when not viewing '**Arrange by Size**'). If this layout is chosen to be exposed, this is then the size of the merged plate.
  - Due dates, shown in red when it is overdue.
  - Waste percentage.
10. Information about the selected layout proposal. Learn more in [Merged Plates](#).
  - **Beams:** This shows the average beam count for the entire layout. This gives an indication how long it will take to expose this layout.
  - **Grouping:** These are the values of the parameters that were involved in grouping these press plates onto a same layout (both system level and custom [grouping keys](#)).
11. As mentioned above, not all layout proposals are shown, only the best ones.

The top screenshot on this page shows such an example:

- The selected proposal (bottom left) for the **Spark 5080** shows that here are 4 press plates for the 'Shrek' job: C, M, Y, K.
- Above, on the smaller plate for the **Spark 2530**, only one proposal is shown, including only C, M, K. There are other layout proposals for this smaller plate, but showing those here brings no extra

value: Or they contain a same amount of press plates from a same set, or their waste percentage is (much) higher. Therefore, in this example, only this one best layout is shown.

### Choosing to Expose a Layout Proposal

When you want to output a layout proposal, right-click it and choose **Expose**.

This will remove it from this view and start the assigned output workflow for this merge queue (creating a merged plate and sending it to the CDI).

When you choose to expose a layout, the current list of proposals disappears. This is because the plate merger immediately recalculates new layout proposals, now using the left-over press plates.



**Note:** You can change a proposal before exposing it. Learn more [below](#).

### Inspecting and Changing a single Layout Proposal

#### Detailed View of a Layout Proposal

In the overview of layout proposals, double-click a proposal to open it in a different view where you can inspect and change it.

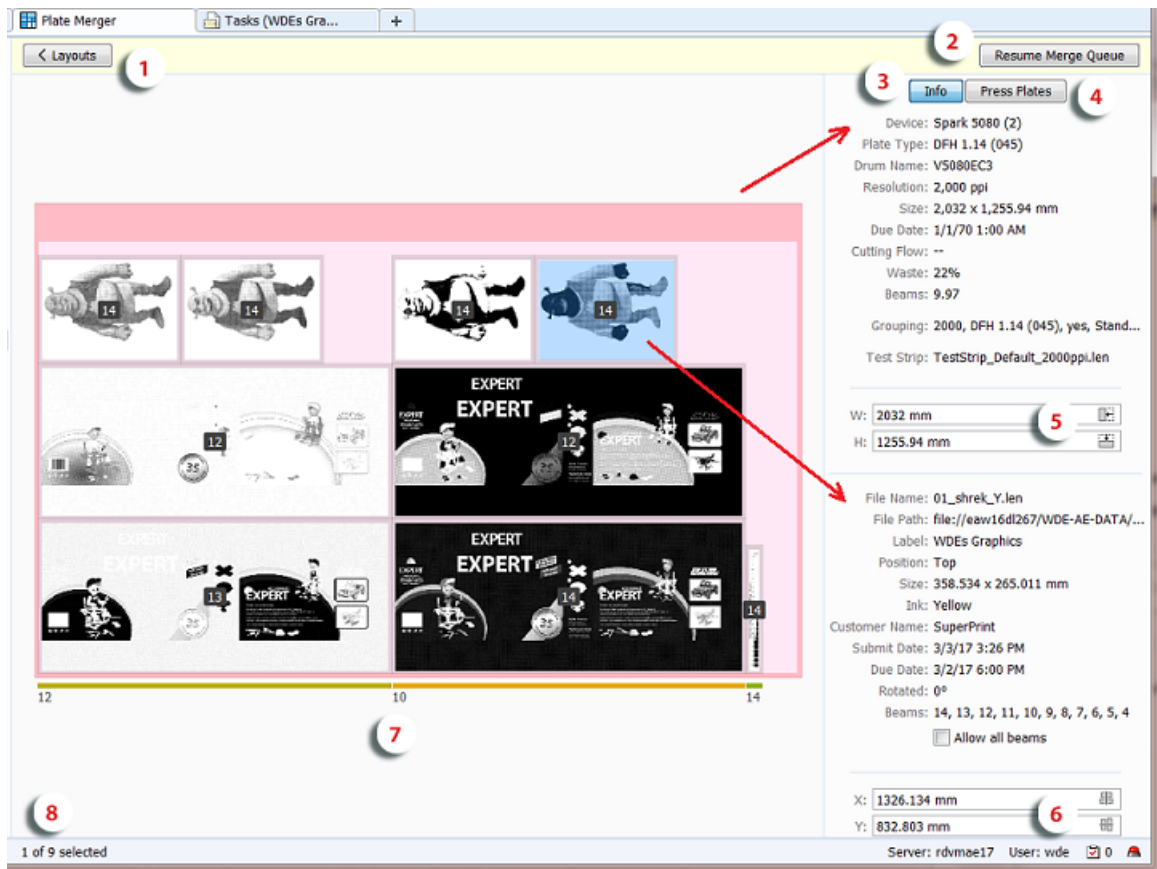

1. Press **< Layouts** to go back to the overview of layout proposals.



**Attention:** When you leave this view, any possible changes to this layout proposal will be lost.

2. Click **Pause Merge Queue** or **Resume Merge Queue** to pause or resume this merge queue. Similar buttons are available when you are viewing **All Merge Queues**.
3. The **Info** button shows a right pane with details about the layout proposal (top) and about the selected press plate (bottom).
4. The **Press Plates** button shows a right pane that assists you when manually placing the press plates. Learn more in [Working with the List of Press Plates](#) on page 1529.
5. This is the width and height of the layout proposal. Use the numeric fields (including calculator) or the [cropping icons](#).
6. This is the X and Y position of the selected press plate. Use the numeric fields (including calculator) to re-position it or use the icons to center it on the layout. Learn more [here](#).
7. This is the beam count for this vertical lane of the layout. Learn more in [Information on Beams used per Lane of Press Plates](#) on page 1526.
8. This indicates how many (selected) press plates there currently are on this layout.

Notice the different colors for sizes and margins:



1. Drum size (grey). This grey area is not visible when the layout is the size of the drum.
2. Layout size (when exposed, the size of the merged plate)(pink).
3. [Merged plate margin](#) (darker pink).
4. [Press plate margin](#) (grey around press plate).

In this mode, you can measure details, inspect beam counts, change the layout and choose to expose it from this view.



**Note:** Editing features that are not available here might be part of the separate application "[DFS Merger](#)" (for example the tools for a PlatePatcher workflow).

**Information on Beams used per Lane of Press Plates**



**Attention:** Information on CTP laser beams is only available for CDI devices.

Sometimes, the urgency of a plate is more important than its waste factor. To help judge the speed that the plate will be exposed with, you also see the predicted amount of laser beams per 'lane' of press plates.

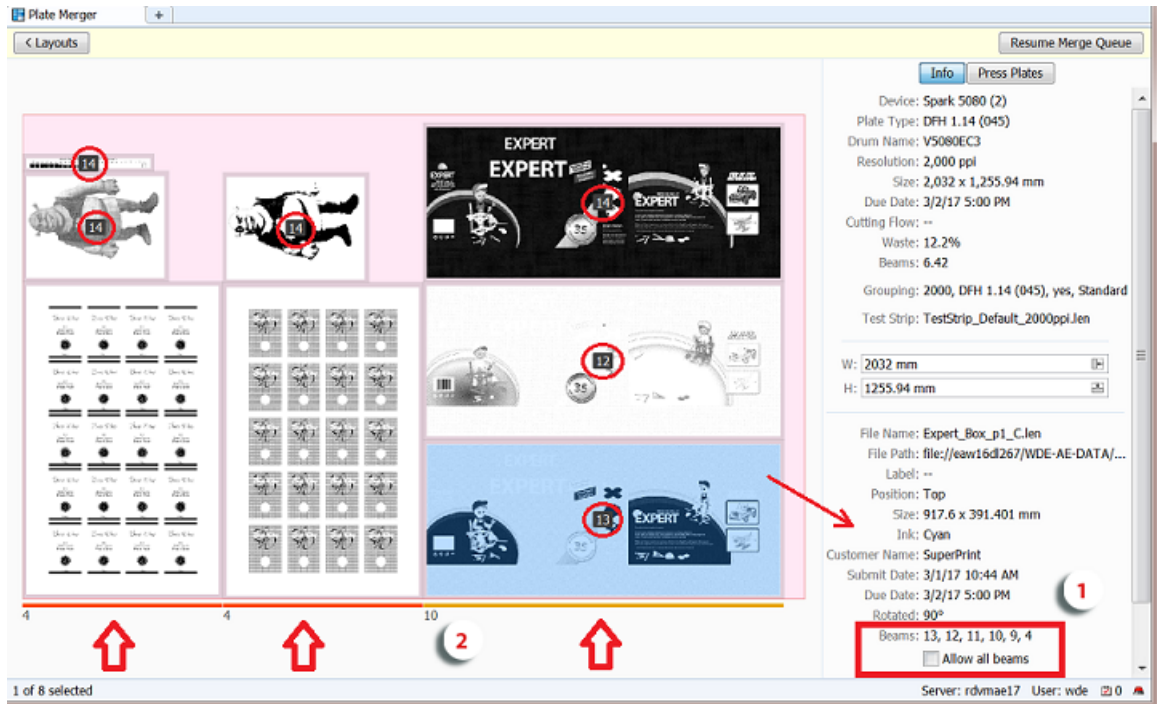

1. In the center of each press plate, the number in the black rectangle indicates the maximum amount of beams that this device can expose this press plate with. For example **14**.



**Note:** This beam count is based on the angle, ruling and resolution of the LEN file.



**Note:** No number is shown when the press plate has no screened data or when its XMP metadata does not mention screening information.

Select a press plate to see more info in bottom part of the details pane on the right:

- **Beams:** This list all possible beam counts for the selected press plate.
- Select **Allow all beams** when you want the beam count only to be based on resolution.



**Note:** In the "DFS Merger", this option is called "Testform".



**Attention:** Enabling this option can cause moiré on the exposed plate.

Some examples cases where this can be useful:

- When there are only solids in the press plates (0 or 100 %).
  - When you do not want the presence of a halftone object to slow down the exposing of the full plate. This could be an image in a test strip or for example a small image that was triggered by a SmartMark. The quality of such images may be less important, so you do not want them to slow down the exposing.
  - When exposing a plate with only test charts where the halftone data is not important.
2. At the bottom of the layout proposal, a small number shows the highest possible common beam count for all press plates in that specific vertical lane (in DFS referred to as 'Stripe'). A random colored horizontal line above this number indicates the width of the lane.

This number is re-calculated every time the layout changes.



**Note:** Sometimes, by *swapping* 2 press plates, you can increase the beam count for a lane, and so expose the plate faster.

When this view cannot detect or calculate a number, it will show the default minimum of '4'. An example: In above screenshot, the press plates of the 2 of the wine label repetitions (bottom left) have no screened data and so the beam count for their lanes is '4'. Solve this by selecting them (one by one) and selecting **Allow all beams**.



**Note:** The beam count shown here is only a calculated prediction. The real beam count used during the exposing is decided by the DFS when it reads the LEN file of the merged plate. This view could for example show '4' because of press plates without screening, while the CDI itself can decide it can and will be higher.

### Changing a Proposal before Choosing to Expose it

This view not only allows close inspection of a layout proposal but you can also make changes to its content or to its size. However, you can not save these changes. These changes only serve to make a more optimized layout right before you choose to **Expose** it.



**Tip:** All changes can be undone (use CTRL/CMD-Z).



**Note:** To select multiple press plates:

- Hold CTRL/CMD while selecting.
- Click and drag an area. All press plates touched by this area will be selected.
- Use CTRL/CMD-A to select all.

Functionality:

- **Moving** press plates:
  - By **dragging**: Select one or more press plates and drag them to another position. The snapping tool helps you to position them accurately (see the assisting blue lines). A dark red color indicates an overlap with other press plates or any position outside the layout area.





**Note:** When multiple press plates are selected, the movement is done on the bounding box of the selection.

Learn about extra possibilities with staggered press plates on [this next page](#).

- **Numerically:** Select one or more press plates, enter a new value for X or Y in the details pane and confirm by pressing **Enter** or **Tab**.

When multiple press plates are selected, the position can be specified in an absolute or relative manner:

- When the entered value starts with + or -, the value is interpreted as a relative value. All press plates are moved, relative to their current position.
- When the entered value does not start with a sign, the value is interpreted as an absolute value. All press plates are then moved to the exact position that was entered (and are probably overlapping).
- **Centering:** Select one or more press plates and, in the X or Y fields, click on  (center horizontally) or  (center vertically).



**Note:** Press plates that overlap or are moved outside the layout area are highlighted in red. Warnings will appear when you then choose to **Expose**.

- **Rotating** press plates:

Right-click your selection and choose **Rotate** to rotate them 90 degrees clockwise or, when they already were rotated in this view, counter clockwise.



**Attention:** Before rotating, the system checks two *options used when submitting these press plates to the plate merger*:

- When one or more press plates were submitted with a forced rotation (*0 or 90*), a warning appears. You can choose to **Rotate Anyway** or **Cancel** this request.
- When you submitted these press plates *without allowing different rotations*, the plate merger might have decided to rotate them all, as a group. When such a group rotation is detected, you will be asked to choose between **Rotate Anyway** (only those you selected), **Group Rotate** (also those in the rotation group) or **Cancel**.

- **Swapping** press plates:

Press CTRL/CMD and click to select 2 press plates. Then right-click this selection and choose **Swap** to make them swap position. Their rotation will not be changed.



- **Removing** press plates:

Right-click your selection and choose **Remove** to remove these press plates from this layout proposal.

- Changing the size of the layout area:

- Automatically: **Cropping** the merged plate. You can crop the (pink) layout area to fit to the area taken by the press plates. This allows you to create a partial merged plate (in case you choose to expose that layout). All required margins will remain.

To do this, click the crop buttons in the W or H input fields:

- Click  to crop and fit the layout horizontally.
- Click  to crop and fit the layout vertically.
- Numerically: Enter a new size in the W or H input fields. Remember you can use these fields as a calculator.

- Right-click a press plate and choose **Go to File** to see the LEN file of press plates selected in the Pilot's **Files** view.
- Right-click a press plate and choose **Info** to open the dialog showing the XMP metadata of this LEN file.
- Right-click a press plate and choose **View** to open the related LEN file in the **Viewer**. This is only possible when prepared view data is available. Learn more in [Viewing RIP data](#).
- Right-click anywhere in the layout and choose **Expose** to start the output workflow for this layout proposal.

**Working with the List of Press Plates**

- In the right pane, the button **Press Plates** lists the press plates that were placed on this layout proposal.

In the list, the icon  below their thumbnail indicates that this press plate is still present on the layout proposal. Those without this icon were manually removed by someone in this view.

To place removed press plates back onto the layout, simply drag and drop their thumbnail onto the layout.

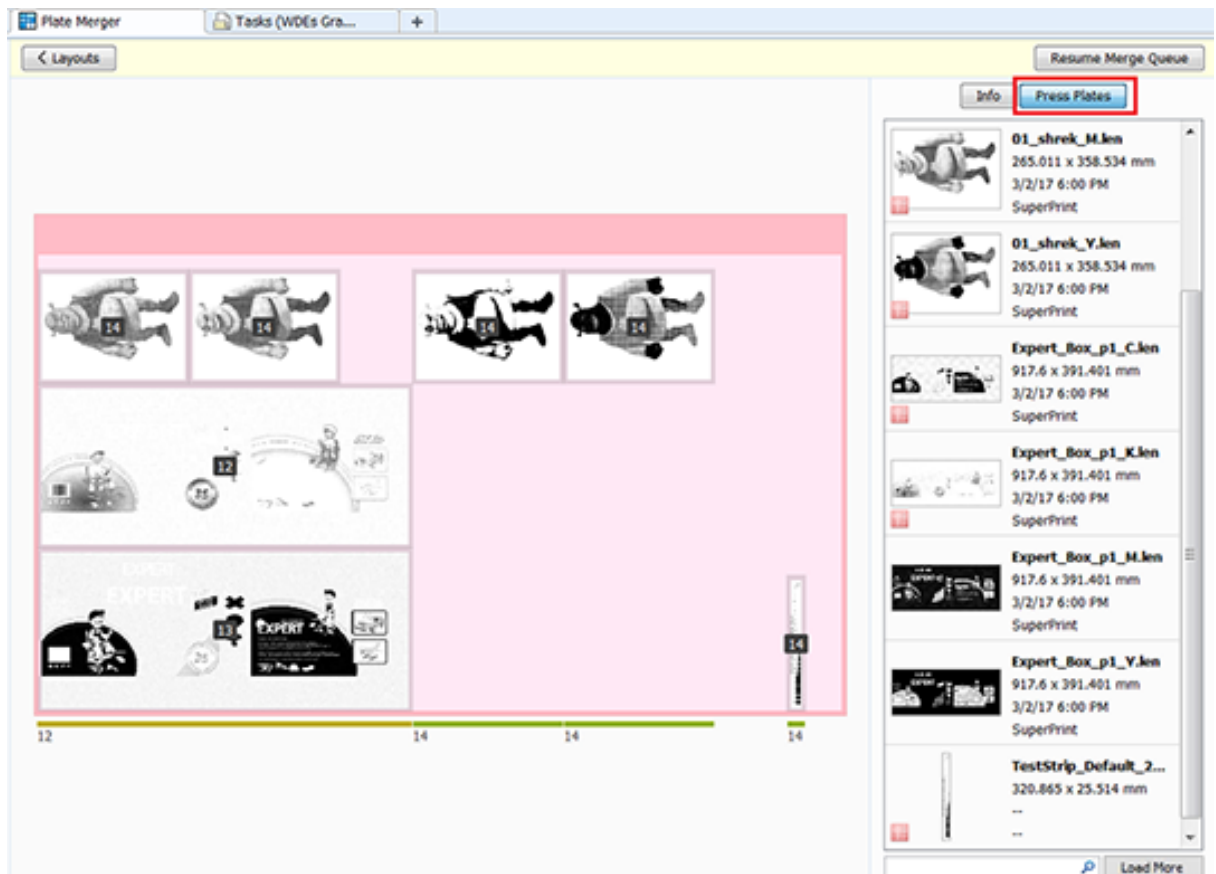

In the list:

- Double click a thumbnail to select that press plate on the layout.



- Use the search field to reduce the list or to find a specific press plate.
- At the bottom of this pane, next to the filter, the button **Load More** request the plate merger to load more press plates in this list (press plates that are part of the current merge queue).

The resulting extra press plates in the list are then also available to be manually placed on this layout.



**Note:** Extra press plates are only considered when they also have these attributes in common:

- Resolution
- Imaging technology
- Cutting flow.

Although press plates that are on hold are not part of any layout proposals, the **Load More** function will also load matching press plates that are on hold. The preview of such a press plate will show the 'hold' icon and offer a tool tip at the bottom left.

When you drag & drop any of these onto the layout proposal, their status (icon) will change automatically.

And when you remove them from the proposal (move them back to the list), they will automatically get their 'on hold' status again.

### Optimizations for Staggered Cut Press Plates

#### Concept

In a layout proposal, the space in between press plates with staggered cut lines is actually also wasted material. In below example, this is the vertical space between the 2 columns:

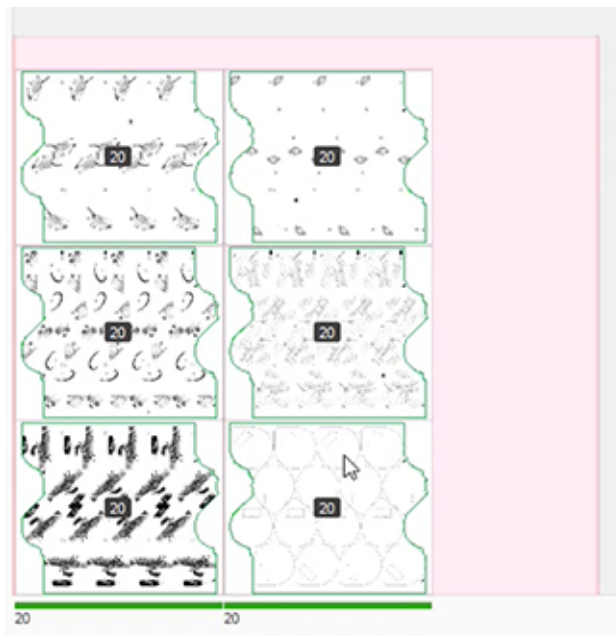

A user can select and manually move press plates into each other, reducing waste and possibly even making room to load extra press plates onto this layout.



### Manual move

You can select and move press plates in a wanted direction. In below example we moved the 3 on the right closer to the ones on the left.

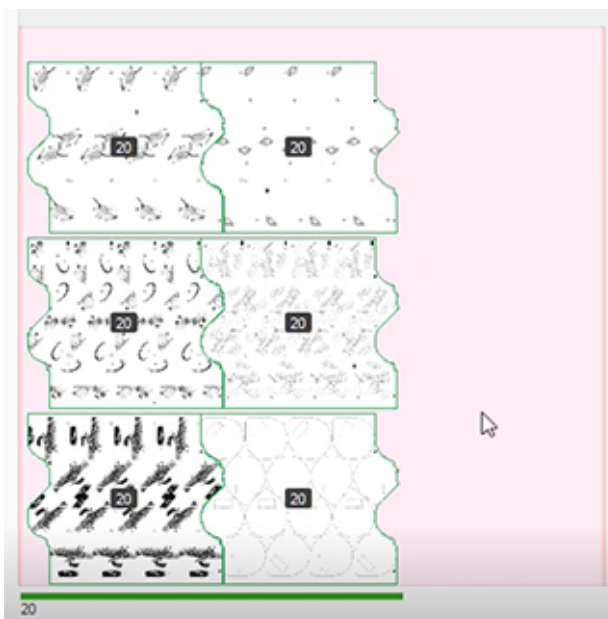
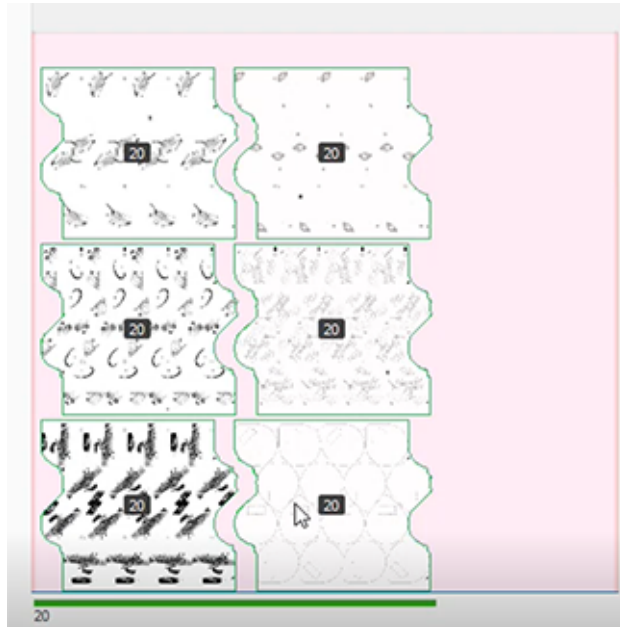

**Note:** As soon as their bounding boxes overlap, you will still see a darker color which is the default way to warn the user of an overlap. You can still go ahead and accept/expose such a layout proposal.



**Warning:** No content should be placed outside the staggered cut lines.

### Load More

In case you now have extra space to load more press plates onto this layout, use the [Load More button](#) (in the right pane at the bottom of the list of press plates).

## 17.2.6. Merged Plates

### Concept

This view gives an overview of all Merged Plates that the [Plate Merger](#) created.

When your Pilot is in 'Last Used Job' mode, you will only see the merged plates of that Job.

Merged Plates are kept in this database until they are removed by the cleanup settings that you define in the [Plate Merger item in the Configure tool](#).



**Note:** This view does not show merged plates that someone created manually in the DFS merger using LEN files from a (local) "working folder". It does show merged plates that the DFS merger made *in "AE mode"* (using press plates that were present in a Plate Merger queue).

Select a merged plate to see a preview and its key attributes in a right pane.

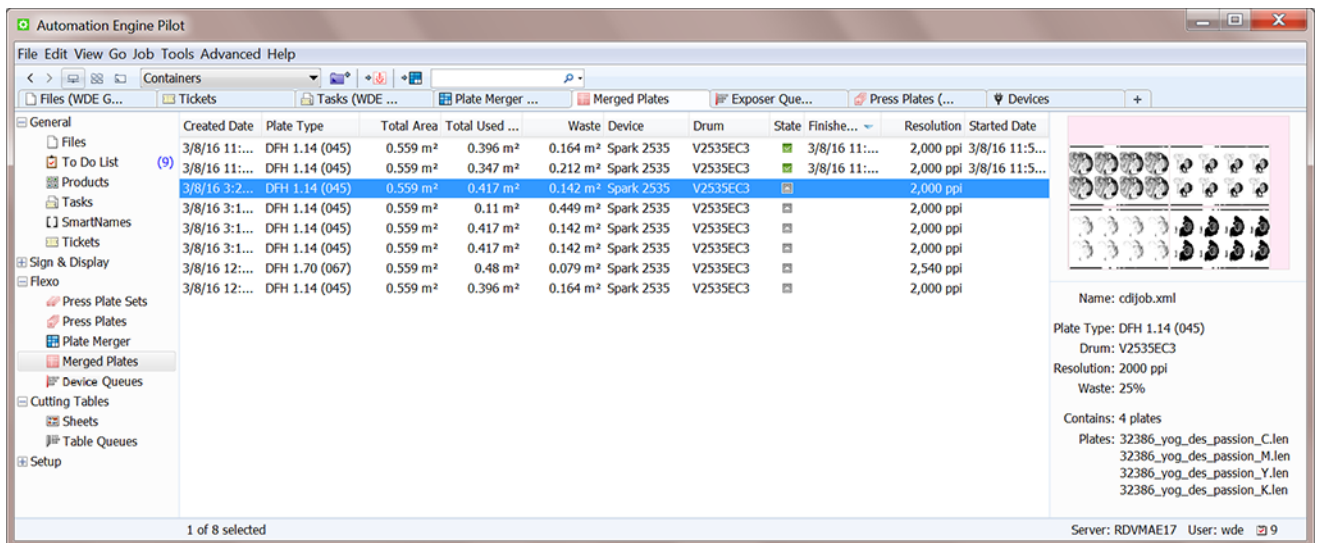

In the preview, the pink area represents the non-used area (waste).



**Note:** *Test Strips* are also shown in the preview and are also counted as waste:

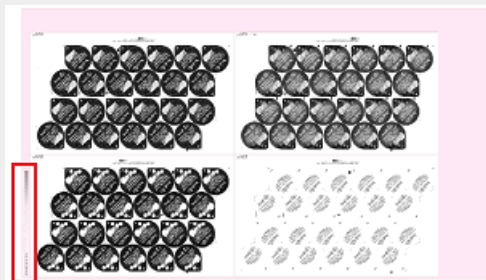

## Columns



**Note:** As in many views in the Pilot, you can

- re-arrange columns by dragging their title to a new position
- sort them by clicking on a column title
- right-click a column title and choose to **Hide** this one or any other. In the list that appears, select **Select Columns...** if you want to change or re-arrange multiple items.
- use filters and optionally save them as a *Smart View*.
- define your preferred unit in **Edit > Preferences > Units**.

Most columns are identical to those already mentioned in the *Press Plates View*. We here only describe those specific for this view:

- **Height** and **Width** of the **Drum**.
- **Total Area:** Height x width, the maximum area that can be imaged (drum surface.)
- **Total Used Area:** Imaged area (the area occupied by press plates on the merged plate).
- **Waste:** Total non used area of the merged plate.
- **Name:** The grapholas parameter file (.par), containing detailed exposing parameters.
- **Estimated:** The estimated **Exposing Time**. For example 12 : 27 means 12 minutes 27 seconds.



**Attention:** CDIs with a Grapholas version 12 up to v14.0 offer a more limited interface with Automation Engine. The estimated expose time is then not accurate ; it will often be too short.

- **Creator:** 'MQ' indicates this plate was created by a merge queue (Automation Engine). The name of that merge is mentioned in **Merge Queue Name**.
- **Merged By:** It describes which technology was used to merge this plate. It can also indicate who manually intervened.
  - **"AutoMergerProposal"** indicates it was done by the automatic algorithm of the **Plate Merger**.
  - **"Manual"** indicates that someone manually intervened in the layout. The network IP number indicates on which computer this was done. The user name is also mentioned.
    - **"\_DFSMerger"** indicates that the layout was decided in the application "DFS Merger".
    - **"\_Pilot"** indicates that the layout was *manually changed in the Pilot before choosing 'Expose'*.

- **% Solvent Saved** and **Solvent Saved Area**: These show the % or square m2 of solvent that was saved on that merged plate. Learn more in [Working with Solvent Saver](#) on page 1561.

### Functionality

After selecting an entry, right-click or choose the icon in the tool bar to:

- **Reconsider:**

This resubmits all the press plates of this entry back to the plate merger and it removes the entry from this device queue. It also removes the entry for that merged plate in the [Merged Plates view](#).

This feature is interesting when you think that you can get a better fill percentage on this merged plate when some of the new (smaller) press plates that recently arrived in the merge queue could also become part of the layout.

-  **Resubmit Merged Plate**: This **resubmits the merged plate back to the CTP device**. A dialog opens where you can choose the device. By default it proposes the one that was used before. When you confirm this choice, you will immediately see it appear as a new entry in the [Device Queues view](#), at the end of the queue of the chosen device queue. When the chosen device is not compatible for this job (due to different imaging technology for example), you will get a warning and you will not be able to resubmit.

Most typical use cases:

- when a flexo plate was damaged and you need to remake the whole plate again, in exactly the same way.
- when the flexo plate (that you do not need to cut) is used for a very long print run and a press operator asks you to create an extra exact copy of that flexo plate.



**Attention:** This does require that the LEN (or TIFF) file of the merged plate has not been cleaned up yet (see setting in the [Plate Merger Configuration](#)).



**Note:** Resubmitting a merged plate also creates, for each press plate on that merged plate, a new entry in the [Press Plates](#) view. It also affects the numbers in the [Press Plate Sets](#) view, in its columns **Merged Plates** and **Press Plates**.

-  **Resubmit Press Plates**: This resubmits all the press plates on this merged plate **to the plate merger** (those same LEN files with their same submit options).

The difference with the above "Resubmit Merged Plate" is that the press plates may this time end up on a different kind of layout, on a merged plate that looks different.



**Attention:** Note that, if the selected merged plate is still in the CDI "Exposer" queue, that this does not remove it from that queue. Also for TIFF devices, this does not remove any TIFF files from the output folder. If you do wish to also remove the item in the CDI "Exposer" queue, then we advise to use the feature '**Reconsider Merged Plates**' that is available on items in [Device Queues](#).

- **Show in Device Queues**: This opens the [Device Queues View](#) with this merged plate selected.



**Note:** When you delete the queue entry there, its merged plate will still be part of the Merged Plates view but its state will be on **Done, with errors**.

- **Open Preview**: This shows the merged plate as it would look in the DFS Merger.

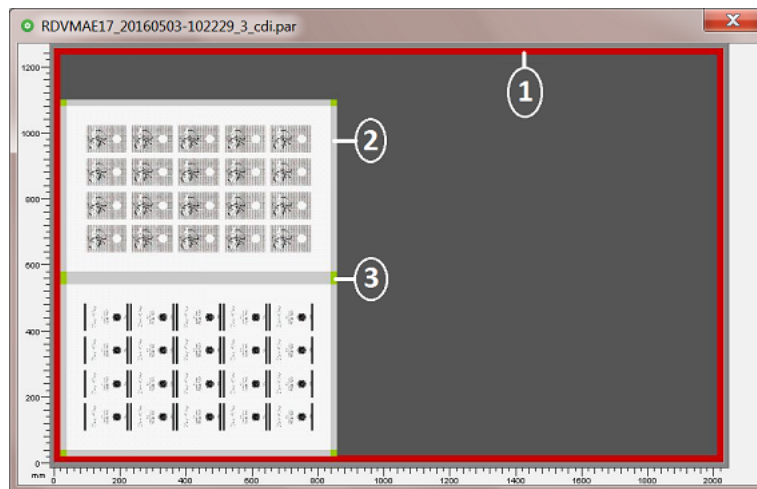

1. The red area indicates the merged plate margins, as set in the [Plate Merger Configuration](#).
2. The light grey indicates the press plate margins, as set in [Merge Settings of the used Merge Queue](#).
3. The green objects indicate cut marks or lines, as set in [Merge Settings of the used Merge Queue](#).



**Note:** This type of preview also shows a preview of any placed [test strips](#).

- **Open in Browser.** This tool is not required in normal daily use, but can be helpful to easily access the files created in background (in the folder as defined in [the Configure tool](#)), for example to read the XML file.

### Zooming in on a Merged Plate

Double click an entry to get a closer view of the content of that merged plate.

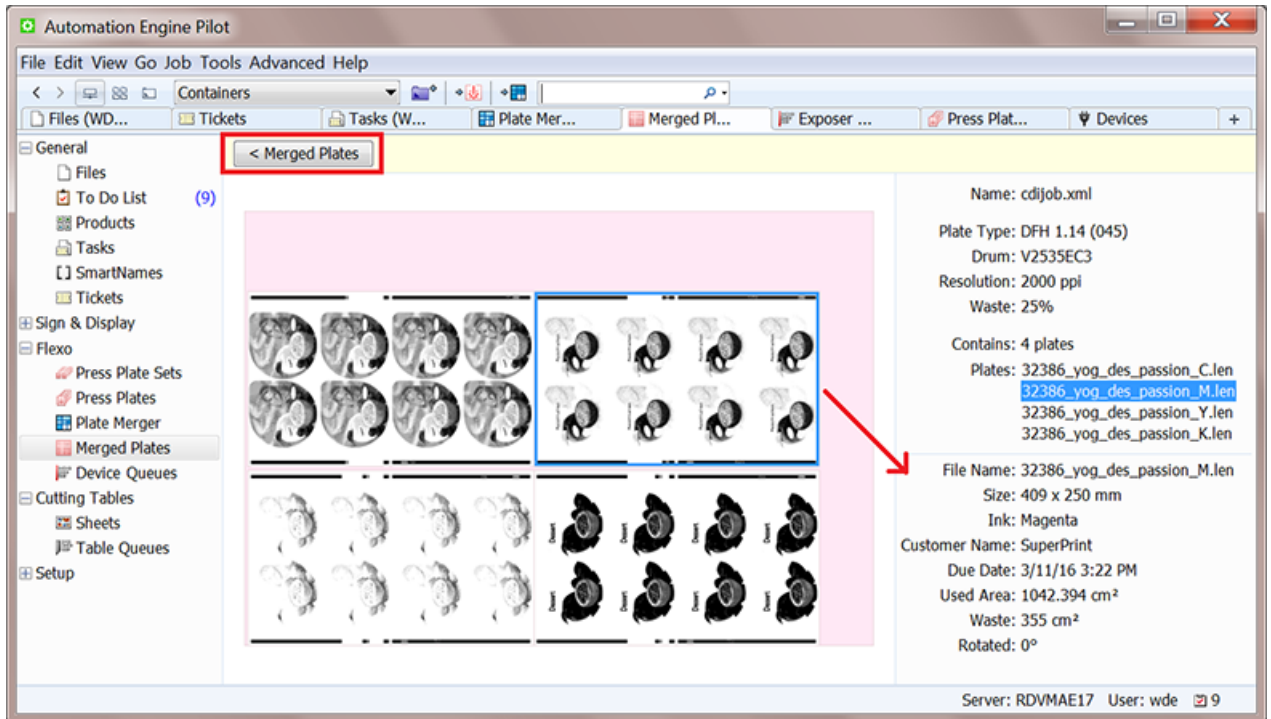

Click the **< Merged Plates** button to see this merged plate back in the main (list) view of the merged plates.



**Tip:** You might have landed on this view directly from another view (for example by using the ["Go to Merged Plate" option in the Press Plates view](#)). If you then want to go back to that previous view, use the toolbar button instead: .

When you select a press plate, its key info is added to the right pane.

You can use **CTRL-click** to select multiple press plates and see their names highlighted in the panel.

**Functionality:**

After selecting one or multiple press plates, a right-click offers to:

- **Resubmit Press Plates:** Also here you can resubmit the selected press plates back to the plate merger, where they will start their workflow again from that point on. The way they are submitted is identical as when they were originally submitted to the plate merger (same plate type, imaging technology, grouping keys, etc.).



**Attention:** This does not remove them from this merged plate and this does not remove the merged plate. This function is therefore useful when the merged plate was already imaged and you later want to image only some of the press plates again.

- **Go to Job:** When the Pilot is in Container mode and when the selected press plate is part of a Job, select this option to filter the Merged Plates view to only those of that Job.
- **Go to File:** Open the Files view and selects the LEN file of the selected press plate.
- **Show in Press Plates:** Shows the selected press plate in the Press Plates view.
- **View.** Opens the press plate's LEN file in the Automation Engine Viewer. This will require the LEN file to have prepared view data (learn more in [Working with RIP data in the AE Viewer](#)).

**Note:** If you wish to open LEN files in the DFS "View" application (aka "Esko Bitmap Viewer", Windows only), then choose 'Go to File' and double-click the file there. This will open the file in the application that you first instructed your local computer to 'open with'.

- **New Task:** Use this tool to select a task ticket to launch on the LEN file of the selected press plate. This is for example how you can submit the selected press plate(s) back to the plate merger but use different options than those that were used originally.

### 17.2.7. Device Queues

The **Device Queues** view shows the queues of configured Flexo devices, both the *CDI* and the *TIFF* devices.

- The queue of CDI device shows what is present in the "Exposer" queue of that CDI. The "Exposer" is the DFS/Grapholas application where you manage the queue and start the actual exposing. This view automatically updates to show new or changed entries.
- The queue of a TIFF device shows the TIFF files that are currently in its *Output Folder*.

You can see these queues in a time line or in a list view mode.

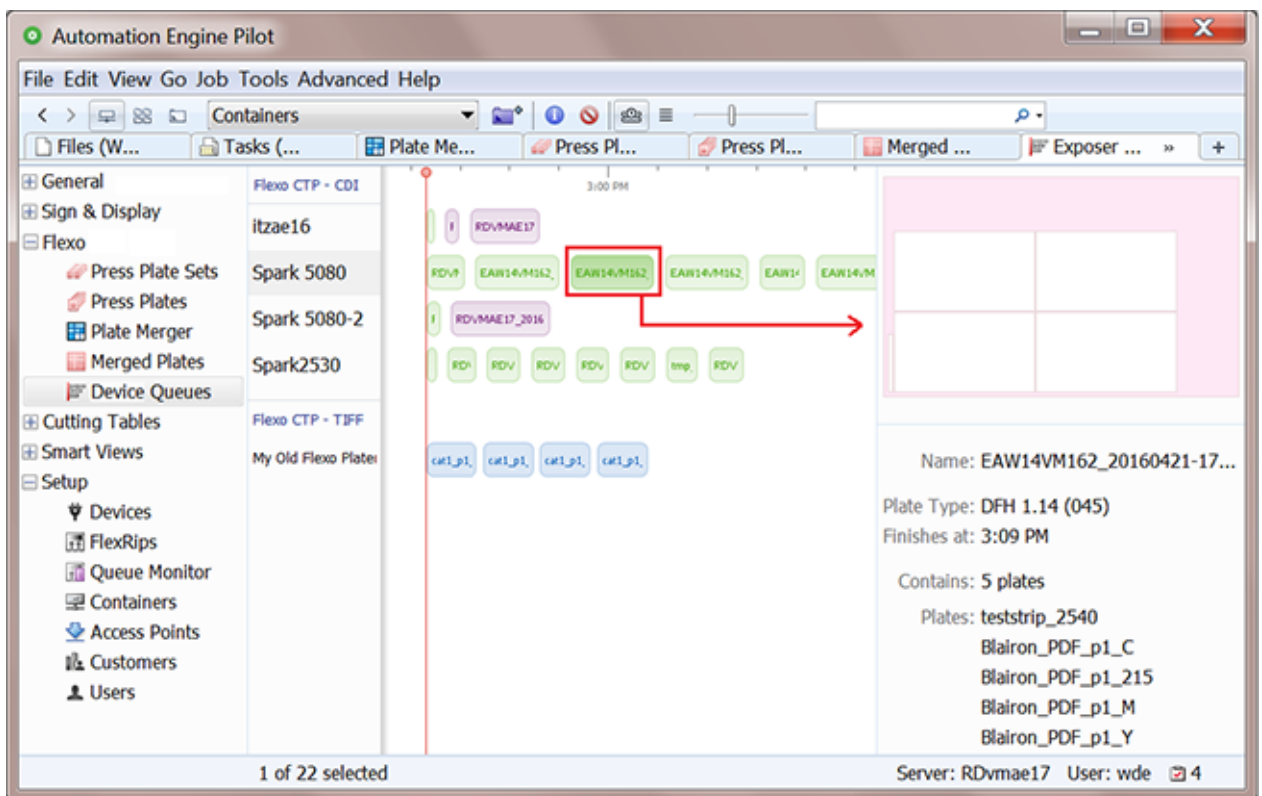

**Note:** Go to **Tools > Flexo Device Queues** to open this view in a separate window. To avoid seeing only Job specific entries, switch to Container view or Jobs Overview before doing this.

**Note:** When a CDI device is offline, this icon appears next to its name: 





**Note:** Before v21.11, the view 'Device Queues' was named 'CTP Queues', and its category 'Flexo' was named 'Flexo CTP'.



**Time Line View Mode**

- Each queue entry is visualized by a rectangle. Its default color is blue.  
For a CDI device, it's length corresponds with the estimated duration to expose that job.



**Attention:** CDIs with a Grapholas version 12 up to 14.0 offer a more limited interface with Automation Engine. The estimated expose time is then not accurate ; it will often be too short.

Entries in a queue of an (offline) TIFF device are always shown by a rectangle representing 30 minutes. The time in between entries, representing a plate change, is a default of 3 minutes.

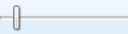
- When an entry is being exposed, that entry moves gradually to the left of the red line. For a TIFF device, the entries appear and disappear as the TIFF files appear or disappear from their output folder.
- Use the slider  to increase or decrease the size of the queue entries.

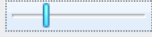

**Tip:** Click on the slider to select it. This is indicated by the blue bar: . At this point you can use the arrow keys to increase or decrease the entries.

- Select an entry to see its details on the right. You can use the left-right arrows to navigate through the queue and change the selection. For TIFF files, only the resolution and size is known.
- When your Pilot is in **Last used Job** mode, all the entries that relate to a different Job are greyed out and can not be selected. Switch to Containers view to make sure you can select any entry.



**List View Mode.**

This view makes it easier to read an entry's name or plate type. You can also click the column headers to sort by that attribute.



**Note:** When your Pilot is in **Last used Job** mode, this list only shows entries that belong to the selected Job.

**Conditional Coloring**

Coloring the entries helps to get a quicker understanding of the queue's content. You could for example assign a color per plate type or per resolution or per urgency (based on due date).

This conditional coloring is applied on all devices and is saved per user, so different users can use different coloring rules.

Follow these steps:





- Right-click the name of any of the flexo devices and choose **Conditional Coloring**.
- **Add** one or more rules.
- Rules are executed top to bottom. Use **Move Up / Down** to change their order.



### Managing Queue Entries

- Search and selecting. Type in the filter field to search on (parts of) a job name or plate type properties. For example, search on the name of plate type or a resolution.



**Tip:** Selections that you make remain active when you switch the  /  view modes. An example: In the  List view mode, sort per column and then make a multiple selection. Then switch to the  Time Line view mode where the selection is kept and then move the selected entries to the front of the queue.



**Tip:** You can also execute below mentioned actions on selections that you made with the filter.

- **Deleting queue entries.** Select and press **Delete** (or right-click and choose **Delete**) to remove entries from a queue. You will be asked to confirm.  
Deleting a queue entry from a TIFF device deletes the TIFF file.  
In the Merged Plates view, you can see how the merged plate still exists but has changed its status to  'Cancelled'. The related press plates and press plate sets also get the status 'Cancelled'.
- **Moving an entry to a different position in the queue.** You can re-arrange entries in a queue by using drag and drop, even on multiple selected entries.

This functionality is not available for TIFF devices.

- **Moving an entry to another queue.** When a CDI needs to go in maintenance, or when you manually want to balance the load, you can drag and drop one or multiple queue entries into the queue of another CDI device.

Because a device is never exactly the same, the merged plate that changes device will always be re-calculated. You will always get feedback and will be asked to confirm.

- The system does various checks if the new device is compatible for this job. When the entry cannot be exposed on the other CDI, you get a warning and the entry will stay in its original queue.
- When the entry can be exposed on the other CDI, you get an information dialog and the entry will eventually show up at the back of that other queue (so not in the place where you dropped it).



**Note:** This is what happens in detail: All device specific data is removed from the layout XML file and the output workflow of the merge queue (where it was originally made) is launched again. This re-creates a merged plate and that LEN file is then submitted to the new device where it appears as a new entry at the back of its queue.

This functionality is not available for TIFF devices.

- **Reconsider Merged Plates.**

This resubmits all the press plates of this entry back to the plate merger and it removes the entry from this device queue. It also removes the entry for that merged plate in the [Merged Plates view](#).

This feature is interesting when you think that you can get a better fill percentage on this merged plate when some of the new (smaller) press plates that recently arrived in the merge queue could also become part of the layout.

## 17.3. Flexo Device related Tasks



**Note:** In a standalone setup of **Device Manager**, several of these tasks are not available.

### 17.3.1. Add Margins to LEN file task



**Note:** The flexo CTP platemaking workflow, its terminology and the Plate Merger are described in the [introduction](#) of this chapter.

#### Concept

This task adds margins to a LEN or LENX digital film file. These extra margins can so help plate mounting or plate re-mounting (PlatePatcher workflow).

Using this task can also make sure that there is (just) enough space between press plates (LEN files) on a [merged plate](#). However, that can also be achieved by using the option **Press Plate Margins** in the [merge settings of a Merge Queue](#). That way, you are not changing the actual press plate LEN files but only adding these extra margins in the calculation of the layout.



**Note:** When you want to add extra margins to a merged plate, then use the plate merger's option to [add margins to the merged plate](#).



**Note:** This task fails when the input file is a LENX file that contains [Plate ID](#) metadata. The Plate ID needs to be [applied](#) first before using this task.

#### Settings

Enter a value per side or use SmartNames to specify the value(s). SmartNames can help automate the fact that your different printers may want different plate margins.



**Note:** You can also enter negative values. That side will then be cropped with that distance. You can however crop the file automatically with the [Crop LEN File task](#).



**Attention:** Some Step & Repeat tasks (and also Plato) offer an option to "**Include CAD info for Digital Flexo Suite**" in the PDFPLA file. This is used to include the technical inks data in the metadata of the output file. In the Bitmap Viewer and in the DFS Viewer, you can see these as layers "Plato Cut" and or "Cut/Crease line registration". A LEN file made from that PDFPLA file will then have that information embedded. However, launching this **Add Margins to LEN file** task or the **Crop LEN file** task on such a LEN file will remove that metadata (layers) and end with a warning. Mind that this does not remove the metadata / layer named "**Staggered Cut**".



**Note:** If you want to view your LEN(X) files after adding margins (for quality control), you can use:

- the Grapholas Viewer,
- the Bitmap Viewer,
- the Automation Engine Viewer, once their view data were 'prepared', either by
  - earlier, in the RIP task, using the Output option 'Make all output files ready for viewing'.
  - or after RIP'ing, using the 'Prepare for Viewer' task.

## 17.3.2. Apply Plate ID to LENX file

### Concept

This task resolves the metadata that describes the Plate ID into the LENX file's pixels. To do that, it uses a pattern that is fit for the selected type of flexo plate.

Learn more about Plate ID in [Working with Plate ID](#) on page 1554.

### Task Settings

- **Plate Type:** Select the type of plate that this LENX file is intended for.

The list shows all plates that are available on the configured *CDI device(s)* and that are *Plate ID enabled*.

### General behavior

- The task supports multiple input files.
- This task will fail in these cases:
  - The input file is not a LENX file.
  - The input file contains no Plate ID data in its Plate ID metadata tag.
  - The input file already contains a patterned Plate ID.
  - A **Plate Type** was selected that doesn't exist (any more) or that doesn't contain the appropriate Plate ID specification.

## 17.3.3. Create Flexo Plate Cutting Paths

### Concept

The feature of creating Flexo Plate Cutting Paths is an alternative to Staggered Cutting in ArtPro or PackEdge/Plato.

It is designed to facilitate seamless printing in non-sleeve workflows. This means that when web fed flexo printing jobs are not using flexo sleeves the flexo material is cut and wrapped around a cylinder. The unavoidable seam will be positioned in between printable objects.

Flexo Plate Cutting Paths is the tool to define the shape of the flexo plates, which will later in the process be sent to a Kongsberg table on which the flexo plates are cut.

A cut path can be used for all separations, or a cut path per separation can be defined.



**Note:** Flexo Plate Cutting Paths can only be created on PDF+ files. If necessary, convert Normalized PDF files to PDF+ first.



**Tip:** When, in a list, you choose 'Select SmartName...', right-click a parameter and select 'Copy Parameter Value' to find out what the SmartName should resolve to. Paste that value anywhere to see the correct possible value.

### Task Settings

The task's settings are the same as documented in the [user guide of ArtPro+](#), in **Prepress functions > Step & Repeat > Flexo Tools > Create Plate Cutting Paths**.

- **Web Direction: Horizontal or Vertical.** The plate orientation versus the printing direction.
- **Plate Width:** Select the page box that defines the plate width.
- **Plate Circumference:** Type a **Custom** value or have the circumference defined **From Grid or Page Box**.
- **Cutting Paths Strategy:**
  - **Optimize plate usage:** Select this to generate cutting paths that make the best use of the flexo plates.
  - **Prefer stagger pattern:** Select this to generate cutting paths that follow the stagger pattern of the grid as closely as possible.



**Note:** This task can detect stagger patterns from Step & Repeats generated in ArtPro+ or other Esko applications. If no stagger pattern is found, the Optimize Plate Usage method is used.

- **Keep Away From Imaged Areas:** Define the distance that a cutting path should keep away from an imaged (printing) area in the file. See the default ticket to see the default values.
  - **Minimum Distance**
  - **Preferred Distance**
- **Corner Radius:** Rounded corners facilitate cutting and avoid damaging the plate when taking it off the cylinder.
  - **Minimum Radius**
  - **Preferred Radius**
- **Gap at Seam:** You might want to make the flexo plate a bit smaller than the repeat length (= plate circumference). The distance between the two identical segments will be 'Repeat Length' minus 'Gap'. The gap is divided equally over top and bottom.
  - **Minimum Gap**
  - **Preferred Gap**
- **Use the same path for all separations:** When not selected, the task creates a separate path for each separation.

When selected, the task will end in error if a single path could not be generated for all separations.

### 17.3.4. Crop LEN File task



**Note:** The flexo CTP platemaking workflow, its terminology and the Plate Merger are described in the [introduction](#) of this chapter.

**Concept**

This task serves to crop a LEN (or LENX) digital film file to the bounding box of all visible objects combined. By default, the task crops the LEN file to first pixel of that separation.

However, when there is a staggered cut line present in the file, the task crops to the bounding box of that line (even if there are pixels outside the cut line). An example:

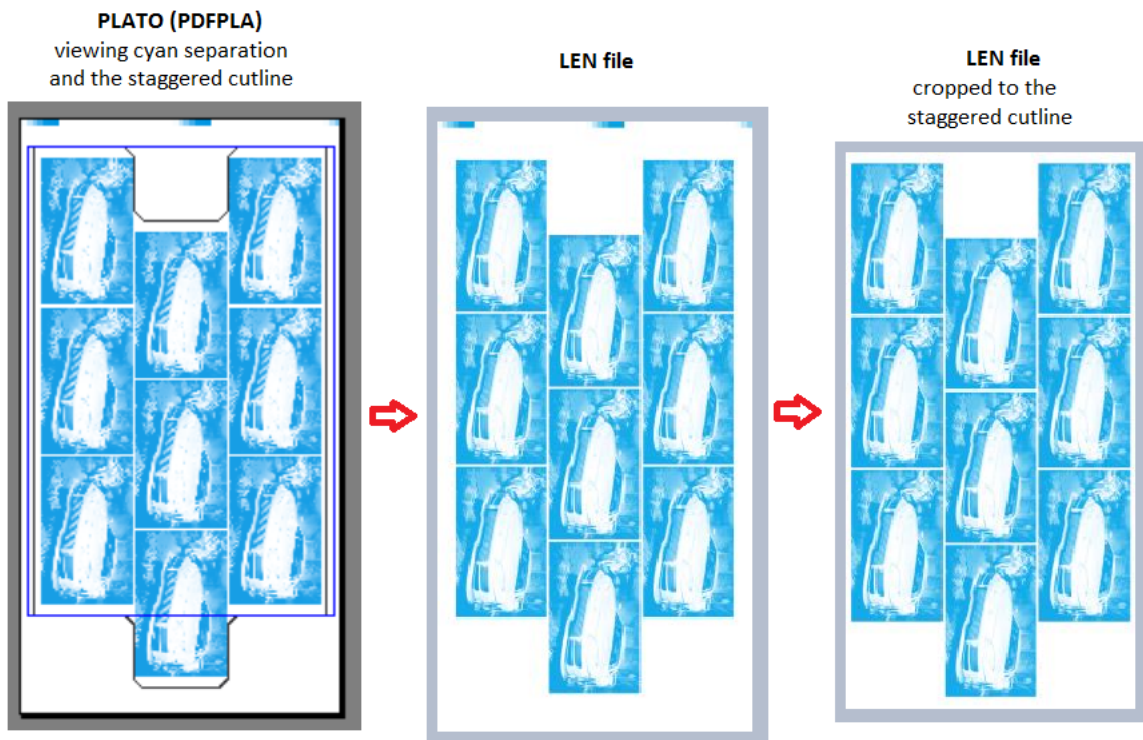

**Note:** A typical workflow might be to first use this task to crop the LEN files and then use the [Add Margins to LEN file task](#) to add margins again (and maybe not on all 4 sides).



**Note:** This task fails when the input file is a LENX file that contains [Plate ID](#) metadata. The Plate ID needs to be [applied](#) first before using this task.



**Attention:** Some Step & Repeat tasks (and also Plato) offer an option to "**Include CAD info for Digital Flexo Suite**" in the PDFPLA file. This is used to include the technical inks data in the metadata of the output file. In the Bitmap Viewer and in the DFS Viewer, you can see these as layers "Plato Cut" and or "Cut/Crease line registration". A LEN file made from that PDFPLA file will then have that information embedded. However, launching this **Add Margins to LEN file** task or the **Crop LEN file** task on such a LEN file will remove that metadata (layers) and end with a warning. Mind that this does not remove the metadata / layer named "**Staggered Cut**".



**Note:** If you want to view your LEN(X) files after cropping (for quality control), you can use:

- the Grapholas Viewer,
- the Bitmap Viewer,
- the Automation Engine Viewer, once their view data were 'prepared', either by
  - earlier, in the RIP task, using the Output option 'Make all output files ready for viewing'.
  - or after RIP'ing, using the 'Prepare for Viewer' task.

### Task Settings

**Bleed:**

- The bounding box of all pixels found in a separation is extended with this bleed. The task then crops to that enlarged area.
- If there is a staggered cut line, the task crops to the area of the bounding box of the cut line, enlarged with this bleed.

## 17.3.5. Submit to Plate Merger task



**Note:** The flexo CTP platemaking workflow, its terminology and the Plate Merger are described in the [introduction](#) of this chapter.

### Concept

This task serves to submit **Press Plates** (LEN files) to a **Merge Queue** of the [Plate Merger](#).

Press plates that you submit to a merge queue can be merged together on a same merged plate,

- when they have the same value for plate type, resolution, imaging technology and cutting workflow,
- and when they have the same value for custom **Grouping Keys** (that you can set up in the [Configure tool](#)).



**Attention:** The plate merger requires that the XMP metadata of the input LEN files contain information on `hsize`, `vsize` and `resolution`. This is the case for LEN files created by Imaging Engine or FlexRip version 14 or higher.



**Important:** LENX files are LEN files that contain Crystal screens. The plate merger will error when he is asked to make a layout for a TIFF device, which does not have the required 'Crystal' technology.

In a workflow, you can add this task after the RIP'ing task. See this example, where the LEN files are first cropped and where also view files are created for the Automation Engine Viewer:

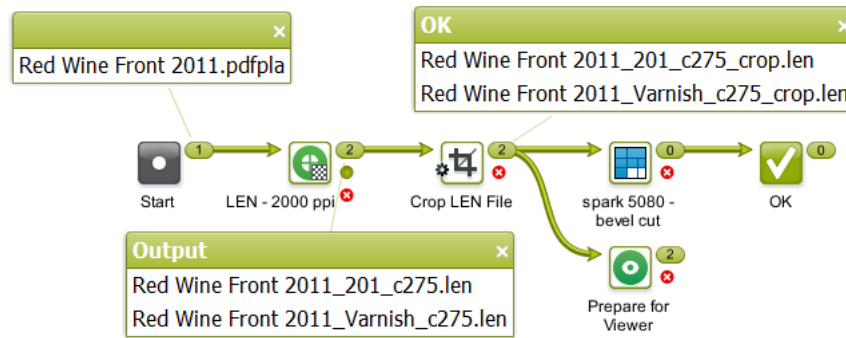

**Tab 'General'**

- **Merge Queue:** Select or name one of the merge queues that you defined in the [Plate Merger](#) view.

**Note:** When a warning sign appears left of the selected name, hover your cursor over the icon to read more about the problem.

- **Rotation:** Define how the press plate may be rotated on the merged plate:
  - **Set by Merge Queue:** This leaves the decision to the merge queue, so allowing it more variants in its calculation of the layout with the best fill percentage.
  - **Force 0:** It will not be rotated, it will stay in the orientation as shown in the press plate preview and as shown in the Automation Engine Viewer.
  - **Force 90:** It will be rotated 90 degrees clockwise.
  - **Select SmartName:** To find out what the parameter value is of an entry in a drop-down list (or of an icon), select that entry from the list, then right-click that setting and choose **Copy Parameter Value**. Then paste that value in any input field. You then can see what the SmartName should resolve to.

**Note:** A rotation (request) on the merged plate is never done on the input press plate LEN file(s). On that level, it is only done when the merged plate LEN (or TIFF) file is created (during the [Create Merged Plate task](#)).

- **Imaging Technology:** Select the imaging technology that these press plates need to be imaged with. This field automatically serves as a grouping key.

This list shows all available technologies on all configured Devices (DFS Merger's). It is automatically updated. Learn more about these technologies in the documentation of [PlatePrep](#).

For any output on a flexo CTP TIFF device, you need to select 'Standard'. Else, they will appear in the plate merger but will be rejected immediately resulting in an error status. The details pane will explain that the selected technology is not available on that device.

**Note:** The technologies **'Speed'** and **'Speed UV'** require Grapholas v19.

**Note:** The technologies **'Speed XPS'** and **'Standard XPS'** require Grapholas 20.1.8 or higher

- **Due Date:** When considering the layout of a merged plate, the merger's main criterion is the fill percentage (learn more in [Plate Merger](#) on page 1501). However, when you here add a due date, the

merger also takes this time into account to make sure you that you have these press plates on the CTP device on time (there as part of a merged plate).



**Note:** The effect of setting a due date can be compared to the *Force Out* option in the merge queue, but then as an automatic step at the specified time.

- **None.**
- Time setting: Select or specify an absolute or relative time.
- **Job due date:** The due date is taken from the due date of the *Automation Engine Job* that the LEN files belong to (residing in its job folder).



**Note:** When the job due date changes, the entries in the merge queue that were submitted with the list option "Job due date" will adapt and reflect this new date. This will only be done if the press plates are still in the Merge Queues. This will not be done if the press plates were already sent to the device queues.



**Note:** When the due date you want is the one from the Job, then do not use the SmartName version ; use this item in the drop down list to avoid any error due to formatting problems.

- **Select SmartName.**



**Note:** If you are using a SmartName for date or time, the resulting format needs to be compliant with ISO 8601 (YYYY-MM-DDThh:mm:ssTZD) . For example:  
2014-07-28T12:00:00+01:00.



**Attention:** When you relaunch a **Submit to Plate Merger** task that had a due date defined on an absolute time, it is then possible that that due date has already passed. This will have the effect that the press plates, the moment they arrive the merge queue, already have the status 'forced out', and therefore quickly disappear again from that queue.

- **Label:** The text you enter here is placed on the merged plate, around each press plate. The text label is placed on the left of the below chosen position, . It uses the font "Arial" and the size is 4 mm. If there was not yet a margin of 4 mm, it will be created automatically on the side where the label is placed.
- **Position:** If you defined a text label, then choose here in which margin around the press plate that the label should be positioned. **Top** or **Left** means on top of or to the left of the press plate as you would see it when viewing it placed on a merged plate and viewed using the "Show preview". When using a SmartName, use `t` for Top and `l` for Left.



**Note:** A label will not be rotated, even if the corresponding press plates got rotated on the layout by the plate merger or manually in the proposals view. When you are eventually holding the physical flexo plate that got produced (in the correct way), then you should be able to find the label for each press plate in a similar place (regardless of any press plate rotation to get to a better layout).



**Note:** If either the label text or position is based on SmartNames that cannot be resolved for one input file, the task will fail for all input files.



**Note:** Before AE v18.1.1, adding a label added a margin of 4 mm on *all* 4 sides of the press plate.

- **Allow different devices and rotations:**



- When this option is not selected, all press plates that you here submit will end up on the same device and have the same rotation.
- When this option is selected, they can end up on different devices and have different rotations. This can result in layouts with less waste.
- **Apply cutting flow:**

Select this option when the merged plate will be cut on a Kongsberg cutting table.

- When that Kongsberg table was also added as a *Device*, then the workflow status will include the status of the cutting on that table. The status 'Exposing Done' will change to '(Cut) Done' once that signal comes back from the Kongsberg table.
- When that Kongsberg table was not added as a device, the required cutting files will still be created but you have to adapt your workflow so that they are provided to the table. Learn more below on [setting up this cutting workflow](#) in the Configure tool (Plate Merger).

This off-line link means that the flexo device workflow can not be aware of the cutting status. It therefore already sets the state of the (merged) Plate to 'Cut = Done' right after the exposing is done on the flexo device.



**Note:** This option is not available when your setup is a standalone **Device Manager**. Contact Esko to learn how to extend this functionality.

- **Cutting Flow.** Select the type of cutting from the drop down list. This field automatically serves as a grouping key.



**Note:** The .xwf files in this list are those on the central resource folder on the Automation Engine server. This is the folder where the DFS merger writes .xwf files when it is in "AE" mode.

The **Cutting Flow** that you define here will later be part of the XML file that, once the CDI plate is made, can automatically be sent to the cutting table. Learn more in the [Configure tool](#), where to define that workflow to launch (in the tab [Setup](#)) and where to define any reporting related to cutting (in the tab [Reporting](#)).



**Tip:** To achieve a better fill rate, the Plate Merger by default merges press plates with and without a cutting flow. However, the plate merger will not merge press plates that ask for a different cutting flow.

In the special case that you never want to mix press plates with and without a cutting flow, you can use a grouping key to prevent this:

1. In **Pilot > Configure > Plate Merger > (Setup)**, pick a custom field, give it the name (for example "Manual Cutting") and select the option "Use as grouping key".
2. Then, when submitting press plates that may **not** be cut on a cutting table, put the value for this custom field ("Manual Cutting") on "Yes".

- **Job Info:** This option is only available when your setup is a standalone **Device Manager**. Consider using SmartNames to pick up job information that came from your MIS.

### Tab 'Custom Fields'

- **Custom Field 1 to 5:** The name of these 5 custom fields is set up in the [Configure tool](#). Their name becomes the name of the columns in several of the CDI related Views. You can then also use their values when filtering. A setting in the **Configure** tool decides whether they will also be used as grouping keys.

### 17.3.6. Create Merged Plate task



**Note:** The flexo CTP platemaking workflow, its terminology and the Plate Merger are described in the [introduction](#) of this chapter.

#### Concept

As mentioned in [Main steps in setting up a Flexo CTP workflow](#) and in [the Plate Merger View](#), this task is the first step of the workflow that the merge queue launches when having created a layout.

The input file of this task is the XML file with all the details of that layout.

The task creates a LEN file of that layout. When the chosen device is a flexo TIFF device, this layout file is a TIFF file.

It also creates previews and other files that are all written in the [Output Folder defined in the Configure tool](#) (where you can also define when these files need to be cleaned up).



**Note:** Creating a large bitmap file is an intensive task for your Automation Engine server. You will also notice that this task takes longer when it first needs to rotate press plates before placing them on the layout.

By default, the **Name** is the name of the input XML file. Use SmartNames to change this. This name will be used as the name for the job in the CDI's **Exposer** queue.

The output of this task is also an XML file. This one refers to the LEN file and other related files it created.

When this was requested for its press plates in their [Submit to Plate Merger task](#), this task also creates the cutting instruction. This cutting file is also referred to in this task's output XML file. Learn more about how and when this cutting information gets to the cutting table [here](#).

#### Settings

- **Name.** Once the output file is submitted to the device,
  - when to a CDI, this is the name of the entry in the CDI's "Exposer" queue. By default, the SmartName [File] will make the CDI job name equal to the name of the XML layout file that the merger created: `<name of AE server>_<date>-<time>_<sequal number>_cdi`.
  - when submitted to a TIFF device, this is the name of the TIFF file written on the queue's output folder.

### 17.3.7. Submit to Flexo Device task



**Note:** Until AE v18.1.1, this task was named 'Submit to CDI'. Tickets that were made in those older versions will still name this task like that. And until v21.11 it was named 'Submit to Flexo CTP task'.



**Note:** The flexo CTP platemaking workflow, its terminology and the Plate Merger are described in the [introduction](#) of this chapter.

### Concept

This task submits a merged plate to a [Flexo Device Queue](#). The input file for this task is not the actual LEN or TIFF file of the layout. The task's input file needs to be the output XML that was created by the [Create Merged Plate task](#).

As mentioned in [Main steps in setting up a flexo CTP workflow](#) and in [the Plate Merger View](#), this task is the last step in the workflow that a merge queue launches once it decided on a layout.



**Note:** This task type can not be re-launched. To resubmit a merged plate to the CTP queue for which it is intended, use the function [Resubmit Merged Plate](#) in the Merged Plates view.

In the Pilot, the task's **Details** pane offers a link to an XML report file. Learn more about what you can do with these report files in [Reporting to Business Systems](#) on page 1489.

## 17.4. Using the DFS Merger in AE mode

---

### Concept

This page illustrates the [semi-automatic workflow](#) that we introduced in the [introduction](#) of this chapter.

### Configuration

To make the DFS 'Merger' application see the merge queues on Automation Engine, the AE server needs to be configured as "**Workflow Server**".



**Note:** The communication between a DFS Merger and Automation Engine happens via JDF/JMF.

Follow these steps to link a DFS Merger to an Automation Engine server:

1. In the DFS Merger, add the name of your Automation Engine server in **Options > Preferences > Merge tab > Workflow Server**.
2. Click **OK**.
3. Test the connection by loading some images from a merge queue (see below).

### Workflow Steps

1. Click the  button. The title bar indicates you are now working in "**AE Manual**" mode. A green background color also reminds you of this different mode.

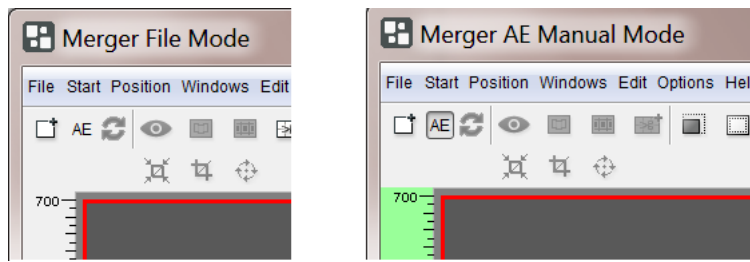

**Note:** To change the mode back to (local) "File Mode", simply click again.



**Note:** This button does not appear when there was a problem connecting to Automation Engine when starting up the DFS Merger.

- Click to load images. A dialog opens that shows the AE merge queue(s) and their contents:

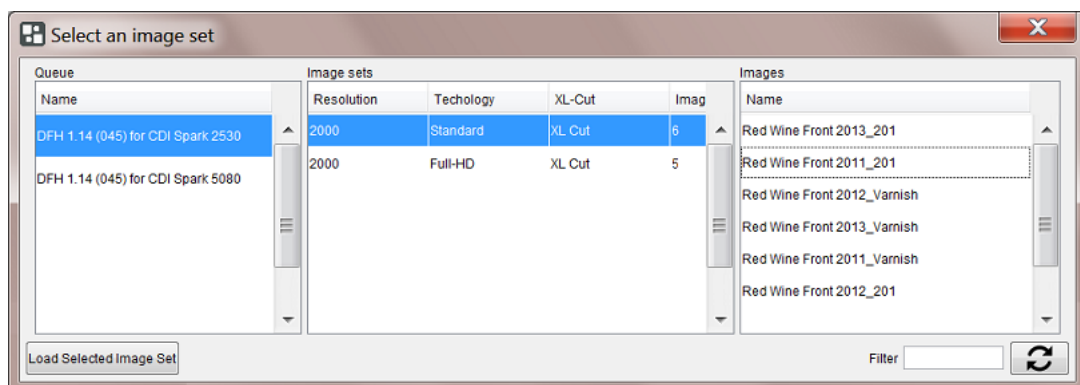

**Note:** Locked items are shown in pink (for example images that you already loaded or image sets being used in another DFS Merger).

- Queue:** This dialog only shows the merge queues that contain images (press plates).



**Note:** Press plates that in their merge queue have the status "Rejected" are not shown in this dialog.

- Image sets:** Sets are groups of images that can be exposed together on the same plate, typically because they have all their *grouping keys* in common. The columns already show some attributes they have in common.



**Note:** *Test strips* are not shown in this dialog. They do appear as a **Loaded Image** after you clicked **Load Selected Image Set**. Learn more below.

- Images:** Shows which images are in the selected image set.
- Filter:** When you type a (part of an) image name in this field and click , you will only see the image sets (middle pane) or merge queues (left pane) that contain images with that (part of their) name. To remove the filter, empty the input field and click again.

- **Load Selected Image Set:** Click this button to add all images of the selected image set to the list of **Loaded Images** in the DFS Merger.

The attributes that these images share (as shown in the columns in **Image sets**) are enforced into the DFS Merger. Also the margins and rotations that were requested on Automation Engine are communicated to the DFS merger (the margins can here still be overruled).



**Note:** When your Automation Engine has a license for automatic merging by the merge queues, clicking "**Load Selected Image Set**" also sends a signal to the selected merge queue: To prevent any further automatic merging, this queue is paused. This way, that merge queue only stays available for manual merging, until one of these actions is taken:

- "**Load Selected Image Set**" was clicked for an image set of *another* merge queue.
- The DFS Merger is no longer in "AE Manual" mode.
- The DFS Merger is closed.



**Note:** When the image set contains a test strip (as requested in the [merge queue's configuration](#)), it will also appear in the list of **Loaded Images**.

- To easily recognize it, its thumbnail will be marked with a letter "T".

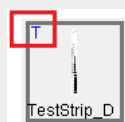

- You can manually place the test strip as any other image.
- When using **CTRL-A (Auto Arrange Images)**, the test strip will be placed bottom left and no other images will be placed on top of it, against that left side of the plate.

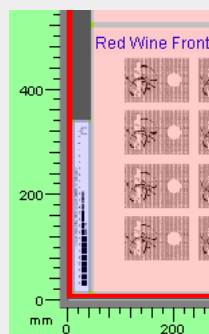

- When using **CTRL-H (Auto Arrange New Images)**, the merger will try to place the test strip in the same place it was placed on the previous plate layout.



**Note:** Click  to check if new images arrived in the image set that you loaded.

3. Now, in the same way as you would do with local images, create a layout with the loaded images.



**Note:** When you have a partial plate that still has the full circumference (vertical size), you can use that plate by first changing the plate's horizontal size.

- When you are finished creating the plate layout and ready to send this layout to the CDI "Exposer" queue, click **Expose!**. You will be asked to fill in a name of this job.



**Attention:** The value you here type in can appear as the job name in the CDI's "Exposer" queue, but only if you also create a specific SmartName and use that SmartName in the [Create Merged Plate task](#). Learn more in [Creating a SmartName for the Merged Plate output File and Queue Entry](#) on page 1552.

In this "AE" mode, when you click **Expose!** (and confirm a name for the job),

- on Automation Engine, the merge queue of the placed images starts its output workflow on this manually created layout.
  - In the DFS Merger, the used images disappear from the list of **Loaded Images** and also disappear from the **"Select an image set"** dialog, because they were also removed from their merge queue.
- On Automation Engine, the Tasks view shows the output workflow. When that workflow is finished, the new job appears in the CDI's [Device Queue](#) that the layout was made for.

### 17.4.1. Creating a SmartName for the Merged Plate output File and Queue Entry

As mentioned in [the page describing the DFS Merger in "AE Manual" mode](#), the name that you type in after clicking **Expose!** can be picked up by a SmartName so that it appears as the name of the job in the CDI "Exposer" queue.

Follow these steps:

- Create the SmartName as shown in this screenshot:

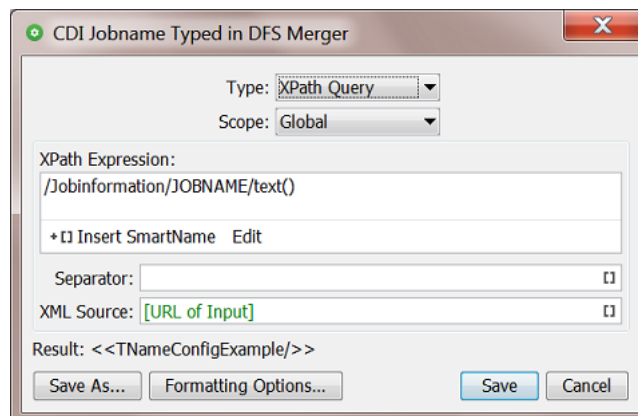

Learn more about creating such SmartNames in [XPath Query SmartNames](#) on page 676.

- Use this SmartName in the [Create Merged Plate task](#) that is part of the workflow launched by the merge queue.

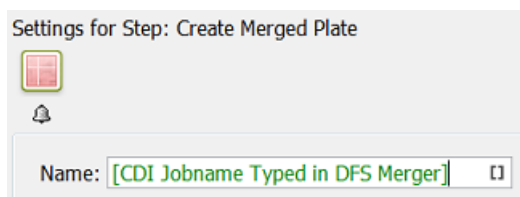

3. Test.



**Note:** When your CDI plate production is mixing the *automatic merger workflow* with this *DFS manual merger workflow*, you can create and use this conditional SmartName:

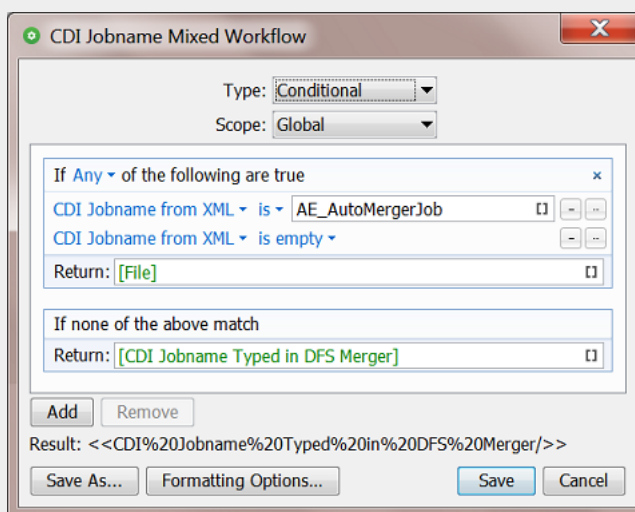

This one checks whether the CDI job name is part of the (automatic merger's) XML file or if it was typed in by a DFS user (if so, it uses the one we created above).

## 17.5. FAQs

### Can I send the information that I see in the Views to my MIS ?

Yes, workflows can send that information to your MIS. Also, your MIS itself can retrieve that info on demand.

See the reporting options in [Plate Merger Configuration](#) on page 1510.

### What to do if a CDI plate is damaged after exposing?

It depends:

- When you want to **re-make the exact same flexo plate**:

Go to the Merged Plates view, select the item and press ("Resubmit Merged Plate"). Learn more [here](#).

- When you only need to **remake specific parts of that flexo plate** (specific press plates):

Go to the Merged Plates view, double click the item to zoom in and see its press plates. Select the wanted press plates, right-click and choose **Resubmit Press Plates**. Learn more [here](#). Alternatively, go to Press Plates view, select the press plates there, right-click and choose **Resubmit Press Plates**.

The resubmitted press plates are now back in the Merge Queue. Use "Force Out" if they are urgent.

- When you want to re-expose **all the press plates** that were on the damaged merged plate, but it **does not have to be the same layout**:

Then go to the Merged Plates view, select the merged plate, right-click and choose **Resubmit Press Plates**.

The press plates are now back in the Merge Queue. Use "Force Out" if they are urgent.

## 17.6. Working with Plate ID

---

### 17.6.1. Concept and Workflow Overview

#### Use Case

Due to their cost, flexo plates are often stored to be re-used later when that exact same plate is required for a future print job. This could be a reprint of the same job or a re-use of that same plate in a similar job.

To find back that one specific plate (that separation of that (layout) job), a plate identification text is added to the plate.

Some still write it manually onto the processed plate, some already add it digitally by using the 'label' feature in DFS or Automation Engine's plate merger. An example:



The disadvantage of adding the plate ID this way is that it consumes a (small) part of the available area where you want to put the actual (merged) printing data. And that ID does not actually have to be printed anyway. You are wasting a bit of (expensive) plate material.



**Added to the plate - in the printing area - but not printing!**

Data that is only imaged halfway the regular height for that type of plate will still be readable on the processed plate but will not print on the substrate, simply because it is not capable of picking up ink.



When we use this technique for Plate ID objects, we can even place it inside the printing area, somewhere in an empty zone for that separation.

Looking at the plate at a certain angle helps to read the half-way imaged Plate ID. An example:



But how do you get that data to be imaged halfway?

How do you achieve something that you normally want to avoid? This time it is actually our goal to have screening pixels creating dots that are too small to survive the processing of the plate.

This is done by applying, only to the Plate ID data, a pattern that makes sure the screened result is just weak enough. i.e. that makes it visible but not printable.

The pattern to be used will be different per type of plate. So you will first have to do a test on each type of plate you use. In your DFS, this will result in Plate configurations that are "Plate ID enabled".

**Workflow overview**

Main steps:

1. In ArtPro+, open the (layout) job that you will RIP and add the Plate ID objects in an available empty area. You can do this manually or by adding Dynamic Marks that also contain such objects. Learn more in [Adding Plate ID Objects in ArtPro+ \(Summary\)](#) on page 1557.



**Attention:** Although ArtPro+ allows to use text, QR code, logo as Plate ID objects. However, in this version, only text objects are supported (further) in the workflow.

2. As usual, RIP the job (CDI - LENX). Learn details about supported devices and screening in [Requirements](#) on page 1556.
3. Once you know on which flexo plate type you will produce the separations, use the special AE task that applies the Plate ID metadata onto the RIP'ed data. This is where the special pattern is used to

reduce the normal screening pixels. Learn more in [Applying the Metadata into the LENX file](#) on page 1559.



**Note:** Any use of the tasks [Crop Len File](#) or [Add Margins to LEN File](#) needs to happen after this step.

4. As usual, either submit the RIP'ed files to the AE Plate Merger or make your merged plate manually by using the DFS Merger application (in 'File' or in 'AE' mode).
5. As usual, expose the merged plate on the CDI, process it, cut it if needed, use it to print and when done, store it for later re-use.

A schematic overview:

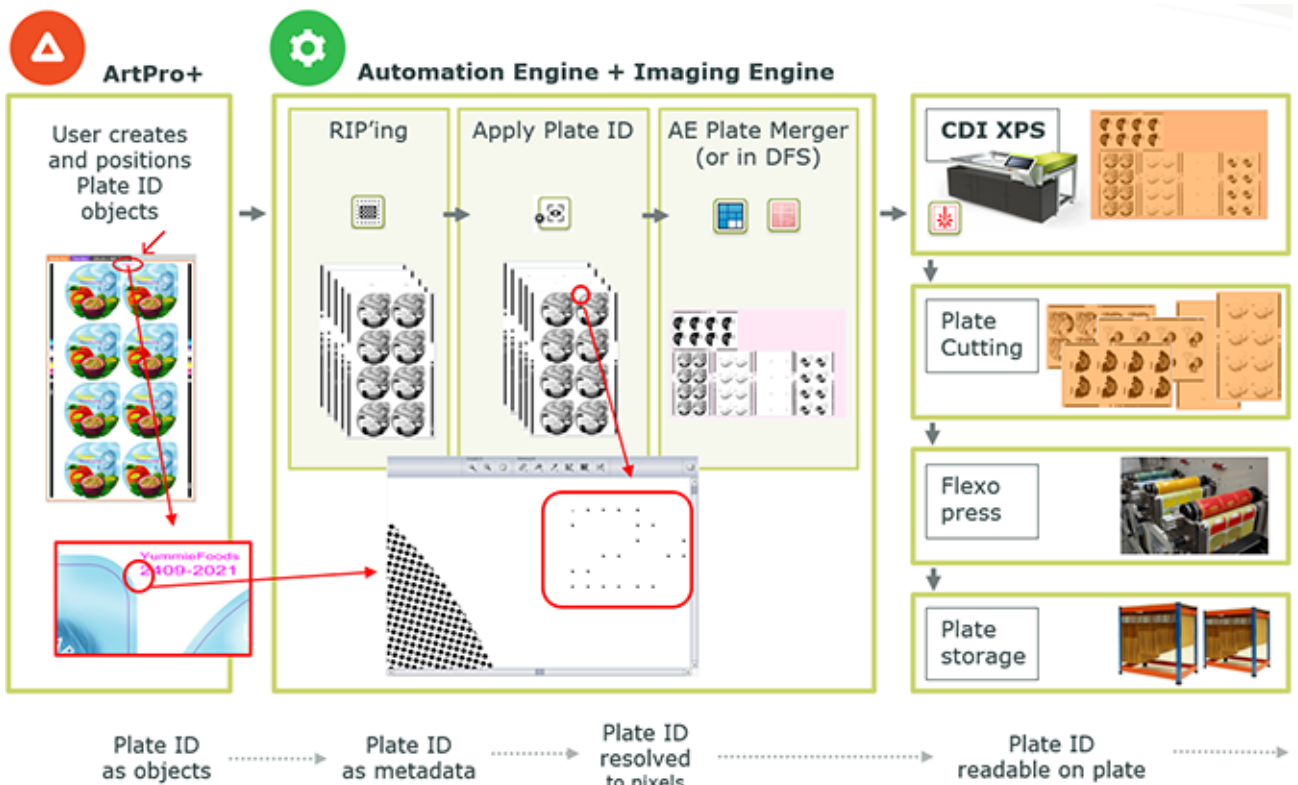

Learn more details in the next pages.

## 17.6.2. Requirements

This workflow requires several Esko software products. Find a detailed description of these requirements on the page of 'Flexo Engine' solution on [www.esko.com/systemrequirements](http://www.esko.com/systemrequirements).

### A summary

- Esko CDI Crystal XPS
  - Only 2540 and 4000 ppi. Pixel Plus is not required.
  - Only for U-fold and Z-fold optics
  - Only for solvent-based plates

- Only plates up to 2,54mm.
- Esko applications:
  - ArtPro+, v21.11 or higher
  - Automation Engine with the 'Flexo Engine' bundle, v21.11 or higher
  - Imaging Engine, v21.11 or higher
  - Grapholas v19.1 or higher / DFS - PlatePrep v20.1.4 or higher
- Other
  - Pattern per plate type and resolution. Determined by means of a test form. Learn how in your [DFS documentation](#).

### 17.6.3. Adding Plate ID Objects in ArtPro+ (Summary)



**Important:** Plate ID uses the processing step technology and is therefore only available for PDF+. The feature is disabled for Normalized PDF files.

Below is a summary. Learn more in the [user guide of ArtPro+](#).

#### Objects you can use in a Plate ID

Not all object types can be used to create a Plate ID object.

- Not allowed: images, Placed Art, clipping paths.
- Not yet allowed in this version of the workflow: images, Placed Art, clipping paths.
- Allowed: in this version of the workflow, only text objects.

#### Static or Dynamic

You can add Plate ID objects as static or as dynamic objects.

- Static: You create and position the objects manually, select them and then choose **Prepress > Flexo Tools > Create Plate ID Object**.
- Dynamic: You add Plate ID objects as (part of) a set of Dynamic Marks.

You can do this in ArtPro+ or by using the AE task [Add Dynamic Marks](#) or any of the Dynamic Step & Repeat tasks. Mind that the task needs to be well aware where to position these objects.

#### Attributes of a Plate ID Object

- Paint:

a Plate ID Object is

- colored in 100% or 0% of the automatically created "Plate ID" processing step colorant (0% if the original object was colored 0%; 100% in all other cases)
- set to overprint
- any transparency settings are reset to blend mode Normal, 100% opacity.

This also implies that gradients and patterns will turn into a 100% flat paint. As this may be obvious for gradients but less so for patterns, a warning will appear about the loss of the pattern.

- Layer:

Plate ID Objects are moved to the "Plate ID" layer.

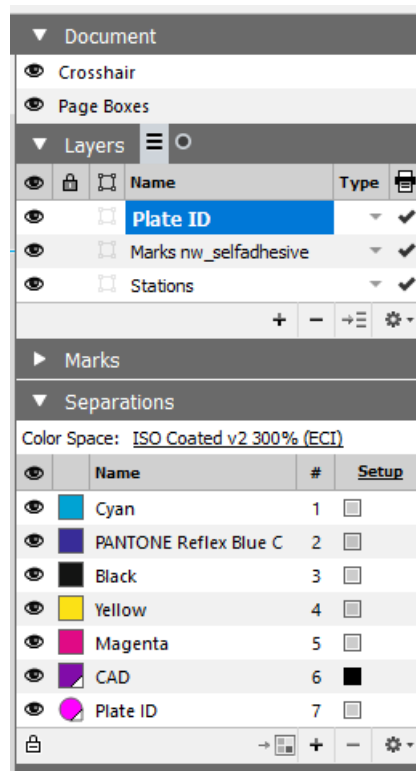

- Separations:

Use the 'Plate ID Object Browser' to decide on which plates the Plate ID Object will have to be exposed.

By default, all artwork separations in use will be enabled. And processing step colorants and unused artwork separations will not be enabled by default, but you can still (de)select any separation.

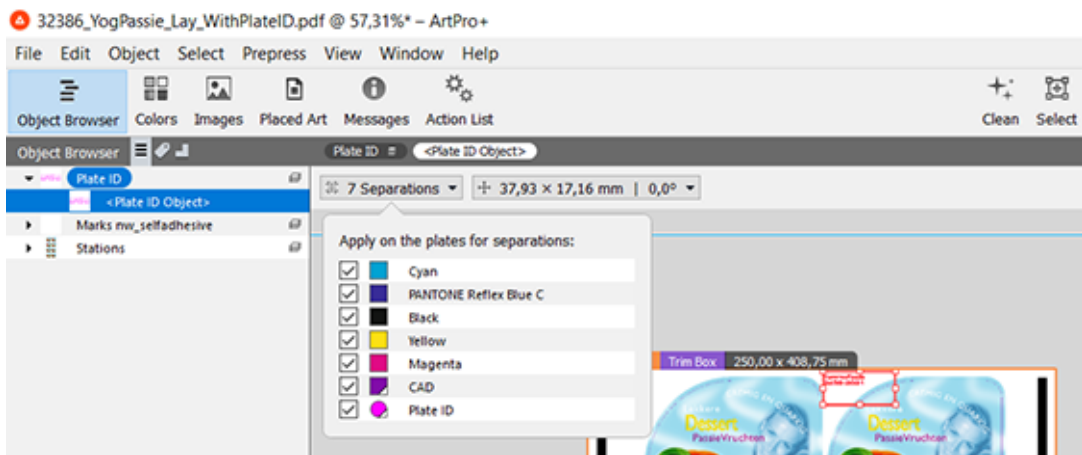

### 17.6.4. Applying the Metadata into the LENX file



**Note:** Once you know on which flexo plate type you will produce the separation, you use the task [Apply Plate ID to LENX file](#) to apply the Plate ID content and merge it with the print image. This is done via the use of a pattern that is specific for the plate type and resolution.

#### Plate ID patterning

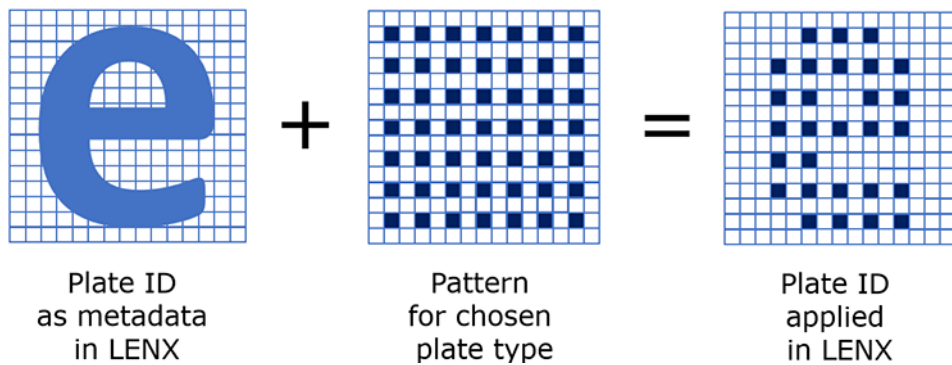

To make sure this task uses the right pattern for that plate type and that resolution, it requires you to select the plate type (one that was [Plate ID enabled](#)).

### 17.6.5. Specifics in the AE Plate Merger

When calculating proposal for a merged plate, the Plate Merger already restricted this to separations that used a same plate type and had a same resolution.

Now, when the Plate merger considers a layout for LENX files, it will also only merge files that used a same Plate ID pattern.

### 17.6.6. Setup in DFS and Testing

#### How to enable a Plate configuration for Plate ID?

This is described in the "**User Guide: Plate ID**" which is available on the documentation page of Digital Flexo Suite: <https://www.esko.com/en/support/product?id=Digital%20Flexo%20Suite> .

### 17.6.7. FAQs

#### Why does the RIP also propose to create a LENX file for the Plate ID objects themselves?

- Plate ID data is logged as a processing step and colorant. As always for processing steps, you can RIP them if wanted. So in the RIP ticket, choosing 'All' in the tab 'Separations' will include this one too. You can deselect this separation or just switch off the type in the tab 'Processing steps'.
- In this case, when viewing the set of press plates in the Viewer, it is useful to have this one separation where you can clearly see the Plate ID objects, for example just to know where they are positioned.
- We also assume you do not use them in output, so you do not submit these to the plate merger or to the CDI.

#### Can I RIP a PDF with Plate ID objects to LEN or TIF?

The Plate ID workflow requires LENX files, but yes you can still select these unsupported file types. In this version there is no warning or error when doing this.

#### Can I RIP a PDF with Plate ID objects with an unsupported resolution?

Yes, but a warning will mention that the Plate ID data will be removed.

#### Can I See the Plate ID in the Viewer?

Yes but only after it has been applied to the RIP data (so after the task 'Apply Plate ID').

This is valid both for the Automation Engine Viewer and the Esko Bitmap Viewer.

#### Can I See the Plate ID in a Layout Proposal of the AE merger?

No. It is not shown in the preview data that is used in that Pilot view.

#### Can I Merge LENX files with Plate ID with LENX files without Plate ID?

Yes you can.

**Can I Merge press plates that used a different Plate ID pattern?**

- The AE automatic merger will prevent this, i.e. not merge these onto a same CDI plate proposal.
- In this version, the DFS manual merger does not check this and will show no error when you are trying to do this.

**I use Pixel Boost. Will that not make the Plate ID print?**

No.

## 17.7. Working with Solvent Saver

**Concept**

The system will add black areas in the waste area around the merged contents, so that when exposing the plate the waste area also gets exposed to UV.

As a consequence the top layer of this waste area will not be washed away by solvent in the washer/plate processor which leads to a reduction in solvent waste or solvent saving.

- Not using Solvent Saver: the wasted area is shown in grey:

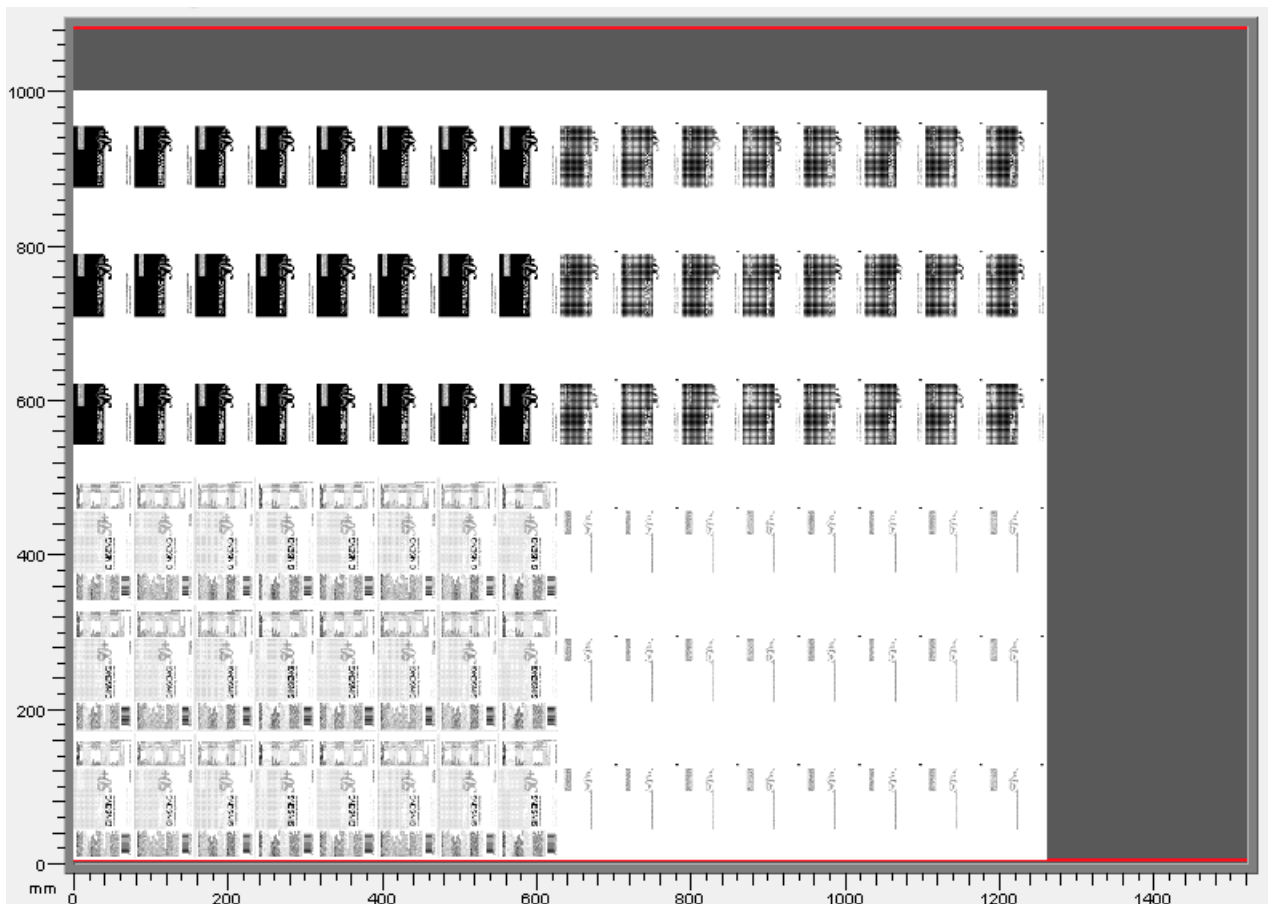

- Using Solvent Saver: the wasted area is shown in black:

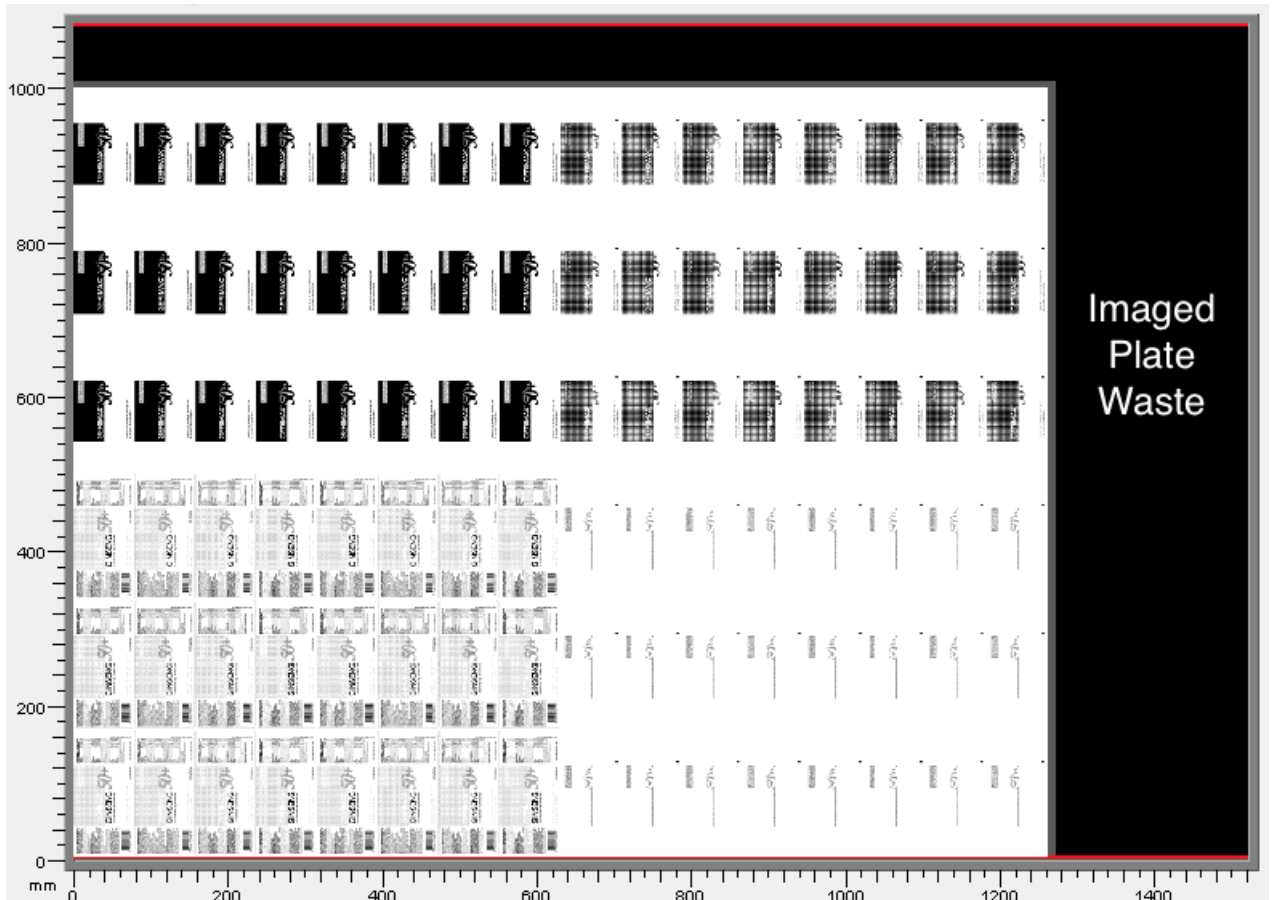

**Restriction:** When combining solvent saver with a cutting flow (option in the [Submit to Plate Merger](#) task) the legacy ACM file format is not supported, only the iPC format.

**Workflow**

1. AE Pilot: Flexo Merge queue: use the solvent saver in its Merge settings.
2. (As usual) image the resulting merged plates on the CDI.
3. (As usual) process the plates.

## 17.8. XML technical details

This section adds technical information to help you interpret some of the XML files that appear in this workflow.

### 17.8.1. Interpreting the Reporting XML files

Reporting XMLs were introduced on [this page about the plate merger configuration](#).

Content wise, there are basically 3 types:



- an XML describing the merged plate that was queued to a flexo device.
- an XML describing the merged plate that was exposed on a flexo device.
- an XML describing, from a job order point of view, details about the current state of the press plates of that job.

Their main content and structure is easy to understand. Below we only illustrate the terms that require some explanation.



**Attention:** Be aware that the terminology in these XMLs uses the vocabulary of the DFS, i.e. a press plate is referred to as an `image` and a merged plate as a `plate`.

The root element of these XMLs is `<FlexoPlateReport>`.

### Terms used when describing the XML element `<Plate>`

The XML element `Plate` refers to a merged plate that is processed on the CDI.

Below described statuses are those at the moment the XML report was created.

- **<ExposeState>**: Possible values are:
  - **MP:QUEUED**: The merged plate resides in the "Exposer" queue of a CDI.
  - **MP:EXPOSING**: The merged plate is being exposed on the CDI.
  - **MP:EXP**: The merged plate has been successfully exposed on the CDI.
  - **MP:EXP\_CANCELED**: The merged plate entry in the "Exposer" queue has been removed before exposing.
  - **MP:EXP\_ERROR**: The merged plate was not successfully exposed on the CDI or no information could be obtained for the merged plate when consulting the DFS.
  - **MP:RECONSIDERED**: The merged plate has been **reconsidered**. It therefore no longer exists.
- **<CuttingState>**: Possible values are:
  - **STC10:WAITING**: The merged plate resides in the queue of an iPC (Kongsberg table).
  - **STC30::DONE\_OK**: The merged plate has been successfully cut on a Kongsberg table.
  - **STC50:DONE\_ERROR**: The merged plate was not successfully cut on a Kongsberg table.

### Terms used when describing the XML element `<Image>`

The XML Element `Image` refers to a Press Plate.

- **<State>**: Possible values are:
  - **ST10:WAITING**: The press plate is part of a merged plate that resides in the "Exposer" queue of a CDI.
  - **ST20:EXPOSING**: The press plate is part of a merged plate that is being exposed on the CDI.
  - **ST30:EXP\_OK**: The press plate is part of a merged plate that has been successfully exposed on a CDI.

- **ST50:EXP\_ERROR**: The press plate is part of a merged plate that has not been successfully exposed on a CDI.
- **ST80:EXP\_CANCELED**: The press plate is part of a merged plate that has been removed from the "Exposer" queue of a CDI.

- **<Plate Id>**:

The 3rd type of XML in the list above, the one that describes all the press plates ( ' images ' ) of a job, also describes on which merged plates ( ' plates ' ) they were exposed on.

For each <image>, its <Plate Id> text value refers to the <Plate> element, with that same value for its attribute "id=".



**Attention:** When you move a job from one CDI device queue to the another CDI device queue, it will get a new plate Id. Systems that interpret the "Submit to Flexo Device" XML reports will then need to listen to that new Id ; there will be no more reporting info related to the old ID.

An example:

```
Plate id="587e-1458-0301" requeueId="587e-1414-1501"
```

"id" is the new one, "requeueId" was the original plate Id before it was moved to another queue.



**Note:** This 'Plate Id' is unrelated to the Plate ID objects and workflow as described in [Working with Plate ID](#) on page 1554.

- **<IdOnPlate>**: This is a unique identifier for the press plate. In the views [Press Plates](#) and [Press Plate Sets](#), you can see (and filter on) them by using the column **Press Plate Id**.

# 18. Kongsberg Production Workflow

---

## 18.1. Intro

---

This chapter describes the workflows where you use Automation Engine to send data to be produced on a [Kongsberg cutting table](#).



**Important:** This chapter assumes you are familiar with a Kongsberg cutting table and its front end application **iPC** (i-cut Production Console). Learn more in the [On Line Help of Kongsberg iPC](#).



**Note:** These workflows require that the version of **iPC** is v2.0 or higher.

### 18.1.1. Workflow Overview and Types

#### Workflow Overview and related Pilot Views





When you set up a Kongsberg table as a [Device](#) in Automation Engine, you can send cutting data to its iPC by using the [Submit to Kongsberg Table](#) task.

The iPC operator sees these items appear in his "My Job List" and can decide when to start its production. The iPC communicates back to Automation Engine about the status of this job and the attributes used for its production.



**Note:** Each iPC is dedicated to one table.

These Pilot Views are used in Kongsberg workflows:

-  [Devices](#) shows your Kongsberg tables (and CDI imagers), their general status and their workload.
-  [Table Queues](#) shows the queue of each of your Kongsberg tables in a time line or list view. You can re-order and delete entries.
-  [Sheets](#) shows a historical overview of all jobs that were processed on your Kongsberg table(s). You can resubmit them and you can export (parts of) this history to an XML file to be interpreted by external systems (order management, calculation, etc.).
-  [Orders](#) (part of the Views category **Sign & Display**). This view shows an overview of the status of all parts of a Job order that were processed by the [Gang Run Merger](#). It helps to monitor orders where multiple graphics need to be printed and cut. This view is documented in the chapter on [Sign & Display Workflow](#) on page 953.

#### Workflow Types

Kongsberg tables are used in many different types of production. When using Automation Engine in this workflow, we here categorize these workflows by how and which files you submit to the iPC:

- [Submitting single CAD files](#). Each CAD file (ARD or MFG) becomes an item in iPC's **My Jobs** list.
- [Submitting nested layouts](#). The iPC Job is a layout created by the Gang Run Printing module.



- [Cutting CDI Plates](#). Typically done to cut DFS PlatePatcher plates (corrugated) or to produce staggered cut plates (rotative sleeves).

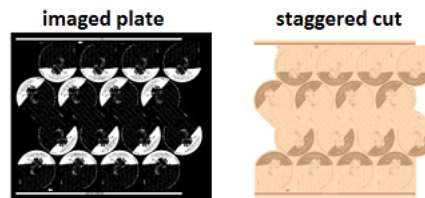

### 18.1.2. Submitting Single CAD Files

#### Concept

In this workflow, Automation Engine sends ARD or MFG files directly to the iPC. Each input file arrives as one job in the iPC My Job list.

This workflow is often used when producing packaging, POP material or box samples.

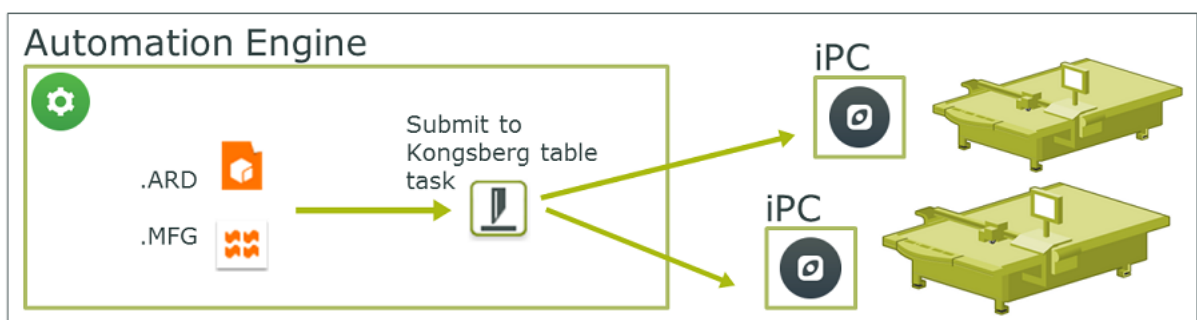

These are its main steps:

1. The ARD or MFG file may be created in ArtiosCAD or exported from Plato or i-cut Layout. The MFG may be the result of manual nesting done in those applications.
2. There may or may not be graphics involved:
  - a. From such interactive applications or via an Automation Engine task, the graphics (PDF data) is exported as well and then printed. The printed sheet is made available at the Kongsberg table.

- b. When producing blank samples of a box or shape, there are no PDF data and the required material is available at the Kongsberg table.
- 3. The cutting file is sent to the iPC by using the **Submit to Kongsberg Table** task. You there choose the table, the amount of copies and other production parameters.

**Main Workflow Steps**

1. Submit ARD or MFG files to iPC. Learn more in [Submit To Kongsberg Table task](#) on page 1579.
2. When successfully submitted, an entry appears in the [Table Queues view](#).
3. The iPC operator places the printed or blank sheet on the table and starts the matching cutting job. An entry appears in the [Sheets View](#).

### 18.1.3. Submitting Nested Layouts

**Concept**

This workflow merges files together before submitting them as one layout to the iPC. The merging is done by the Gang Run Printing nesting server. This merger can also make layouts where items are nested to optimize material usage.

This workflow is often used when producing signage.

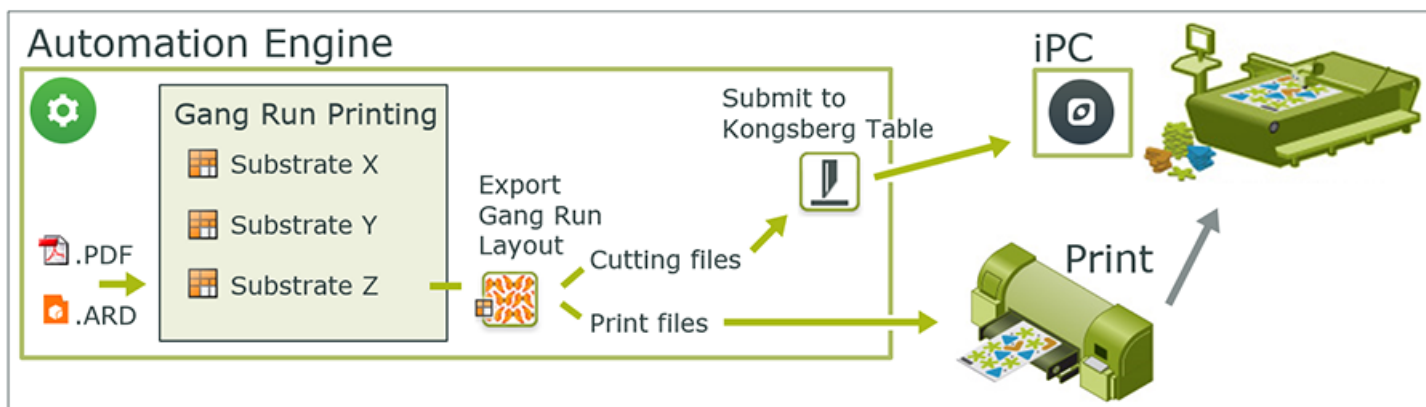

**Note:** ARD cad files sent to this merger will only merge with other ARD files.

**Main Workflow Steps**

1. In the Gang Run Printing merger, set up merge queues per substrate, define how and when they can make layouts and how they should export the resulting nested layout.



**Note:** This tool and workflow is explained in the chapter [Sign & Display Workflow](#) on page 953.

2. You then use the [Submit to Gang Run](#) task to send files to a substrate queue.
3. The substrate queue's output workflow needs to contain at least these tasks:

- The [Export Gang Run Layouts task](#) creates print files that are then printed (unless the layout is of ARD files) and it also creates *cutting files of the type "JDF (Kongsberg)"*.
- The [Submit to Kongsberg Table task](#) then needs to submit the cutting files to the Kongsberg table.

An example:



4. As soon as the JDF cutting file is submitted to the iPC, an entry appears in the [Table Queues View](#).
5. The iPC operator places the print on the table and starts the matching cutting job. An entry appears in the [Sheets View](#).



**Tip:** To easily find which cutting job matches which print job, you can use the **i-cut Marks** in I-cut Layout to add a special barcode to the printout that contains the name of the cutting file. When the iPC operator then scans that barcode, iPC automatically loads the matching cutting job.



**Note:** See a more detailed example of such a workflow at the end of this chapter in [Workflow Example](#) on page 1582.

### 18.1.4. Cutting CDI plates

#### Concept

In this workflow you use a Kongsberg table to cut a flexo plate that you made on a CDI. This is often used when the flexo plate contains separations with a staggered cut or contains small parts of a DFS PlatePatcher workflow.



**Note:** Learn more about using Automation Engine to automate your CDI workflow in the chapter [Flexo CTP Device Workflow](#) on page 1482.

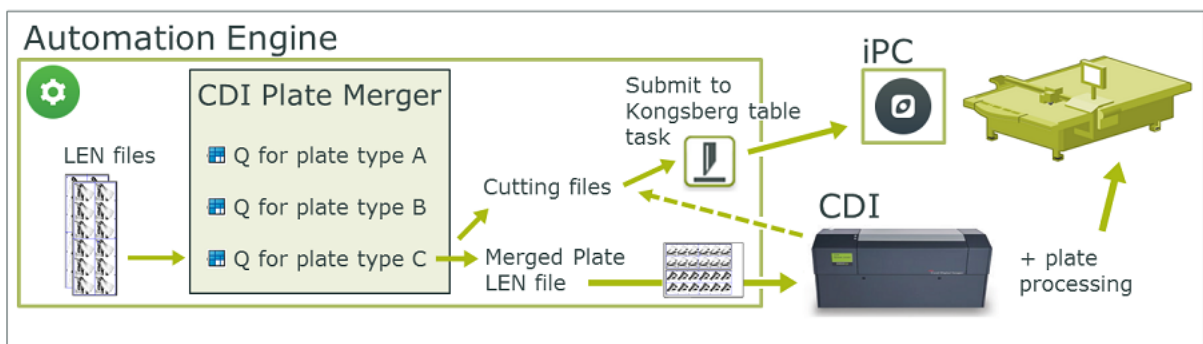

The output workflow of a [CDI Merge Queue](#) creates a special XML file containing the cutting instructions. When the CDI sends a signal that the (merged) plate was imaged, a workflow starts that [submits that XML file to the Kongsberg table](#).



**Important:** When working with Normalized PDF files, there is an alternative way to define cutting paths for the CDI plates. Learn more below in [Advanced Free-Cut workflow \(Classic\)](#) on page 1569.

### Main Workflow Steps

1. A RIP creates LEN files, one for each separation that needs to be imaged on the flexo plate.
2. If needed, LEN files can be processed using [specific Automation Engine tasks](#).
3. They are then [submitted to a specific queue of the Plate Merger](#). Selecting the option **Apply cutting workflow** triggers the generation of the cutting data further in the workflow.



**Note:** The option **Apply cutting workflow** is also used as a grouping key in the Plate Merger.

4. When the **Merge Queue** decides on a layout, it starts a workflow that creates a **Merged Plate** LEN file. Now, as was requested when submitting its parts, also a cutting XML file is created.
5. The merged plate LEN file is submitted to the CDI.
6. When the CDI signals that the plate was imaged, the cutting XML file is automatically submitted to the Kongsberg's iPC (when this was so asked in the [CDI Plate Merger configuration](#)).



**Note:** The flexo plate cutting workflow is also possible when the Kongsberg table is not known as a Device (i.e. its iPC is not on-line). Learn more in the description of the option 'Apply Cutting Workflow' in the [Submit to Plate Merger task](#) on page 1544.

7. The flexo plate is post-processed and then moved to the Kongsberg table.
8. The cutting job is already in the iPC My Jobs list. The iPC operator loads the plate and starts the cutting.

## Advanced Free-Cut workflow (Classic)

### Advanced Free-Cut

Advanced Free-Cut is the name of an alternative way to define free cut paths when working with normalized files.

We here describe the 3 main steps how, in a normalized PDF, technical inks with the name 'FREECUT' can also be used to define cutting paths for a Kongsberg cutting table.

### Workflow steps

1. In the normalized PDF file: follow this syntax for naming the technical ink(s) that contain a cutting path:
  - **FREECUT\_ALL** : When this cutting path will be used for all inks (that a plate is made of)
  - **FREECUT\_** : When there are different shapes per ink. Example: name it FREECUT\_C when it should be used to cut out the cyan plate.

- **FREECUT\_<short ink name>+<short ink name>+<short ink name>** : When you want the cutting path to serve all inks listed between the '+'. Example: FREECUT\_K+WHITE

One FREECUT ink for ALL separations

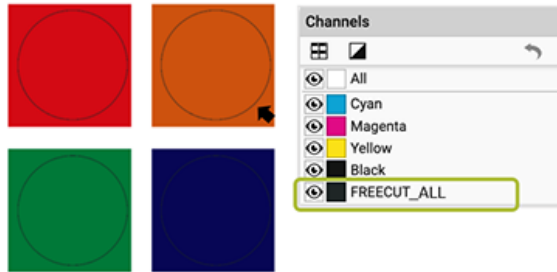

FREECUT ink PER separation

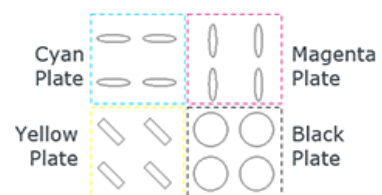
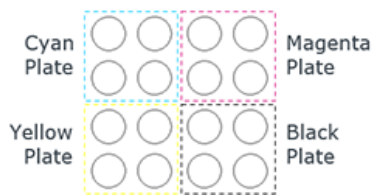
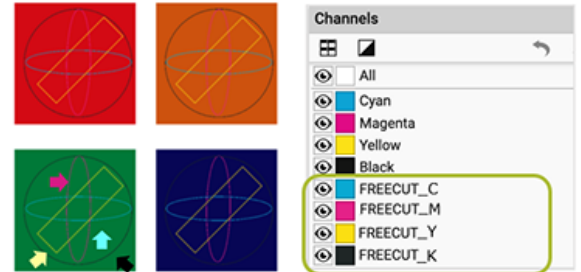

Important is that the LEN(X) files at the end of this workflow have the naming convention as defined here.



**Note:** This naming syntax is not case sensitive.

2. In the **classic** Step & Repeat tasks or in the classic Esko editor Plato, select the option **Include CAD info for Digital Flexo Suite**.

- In the task *S&R Tabular (Classic)*, in the tab 'General':

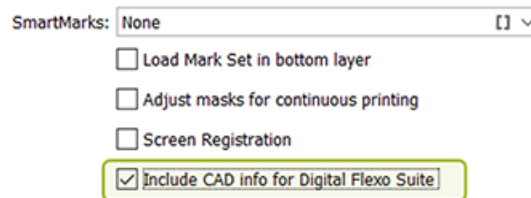

- In tasks *S&R CAD based (Classic)* and *S&R Template based (Classic)*, in the tab 'CAD options':

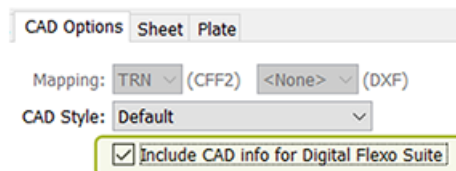

3. In the task *Submit to Plate Merger*, select the option **Apply cutting flow**.



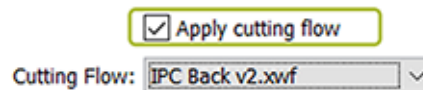

## 18.2. Kongsberg Related Views

These views were introduced in [Workflow Overview and Types](#) on page 1565. We here describe them in detail.

### 18.2.1. Devices (Kongsberg)



**Tip:** You can also open the view **Devices** as a Tool: Go to **Tools > Devices** to monitor and manage your devices in a separate window.

#### Adding a Kongsberg Device

Follow these steps to add a Kongsberg table in this view:

1. In Devices View, click on .
2. Select the category **Kongsberg Tables**.
3. In **Server**, enter the name of the computer or the IP address of the iPC workstation of that specific Kongsberg table.
4. Click **Add** to confirm. The status box of the newly created device appears.



**Note:** Adding a Kongsberg device requires a license per device.

#### Information and functionality

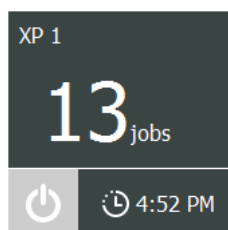



The device status box shows:

- The **name of the device**. By default this is the name of the iPC workstation. Open the **Info** panel to change it to a custom name.
- The **amount of jobs in its queue**. This is the amount of jobs in iPC's **My Jobs** list (processing and waiting).







**Note:** These jobs could have been added via Automation Engine or manually by the iPC operator.

- A **device status icon**.

- : Retrieving the status.
- : Offline, there is no connection with iPC computer (switched off, network problem)



**Note:** Technically this means that Automation Engine can not contact the "Kongsberg Queue Server"(KBQS).



- : The device is online (computer can be accessed, KBQS is running) but the iPC application is not started.
- : Idle, the table is online and ready to produce (KBQS is running and iPC is started).
- : Producing. One job in the queue is in status 'started'.
- : Trying to connect to the device (to the KBQS service on the computer).
- The **Estimated time** when the current job load will be finished (how long the device is scheduled to be busy). This time includes the manual table operations that are needed between jobs.



**Note:** This setup time is configured in iPC: Go to **Edit > Options > Estimation Settings**.

Double click a status box to open the device's **Info** panel.

Right-click a status box to choose one of these options:

- **Info** (or press ). This dialog shows details about the device (version, settings, etc.). You can add a **Description** to illustrate or help identify this device.
- **Delete** (or press ). You will be asked to confirm.



**Note:** Deleting a device will not remove the related entries in the [Sheets View](#).

- **New Device....** An alternative to clicking .

## 18.2.2. Table Queues

### Concept

This view shows the content of the **My Jobs** list of the iPC of the Kongsberg tables that you configured in the [Devices](#) view.

You can see these queues in a time line view or in a list view.

The total number of jobs is mentioned in the bottom bar.

When a table is not on-line, an  icon appears behind its name and the corresponding queue will be shown empty. The view updates as soon as the table is on-line again.

When selecting a job (click or use arrow navigation), the right pane shows a preview and its key properties. When ARD or MFG files were submitted, a preview will only be available after the job was verified or saved in iPC.



**Note:** The right pane will also show the number of **Copies Produced** and **Copies Rejected** of this sheet/layout. An IPC operator can set this manually, for example when a knife broke. These numbers are also shown in a column in the Sheets view.

This view is independent from whether the Pilot is in **Container** mode or in **Selected Job** mode (it always shows the complete queue).

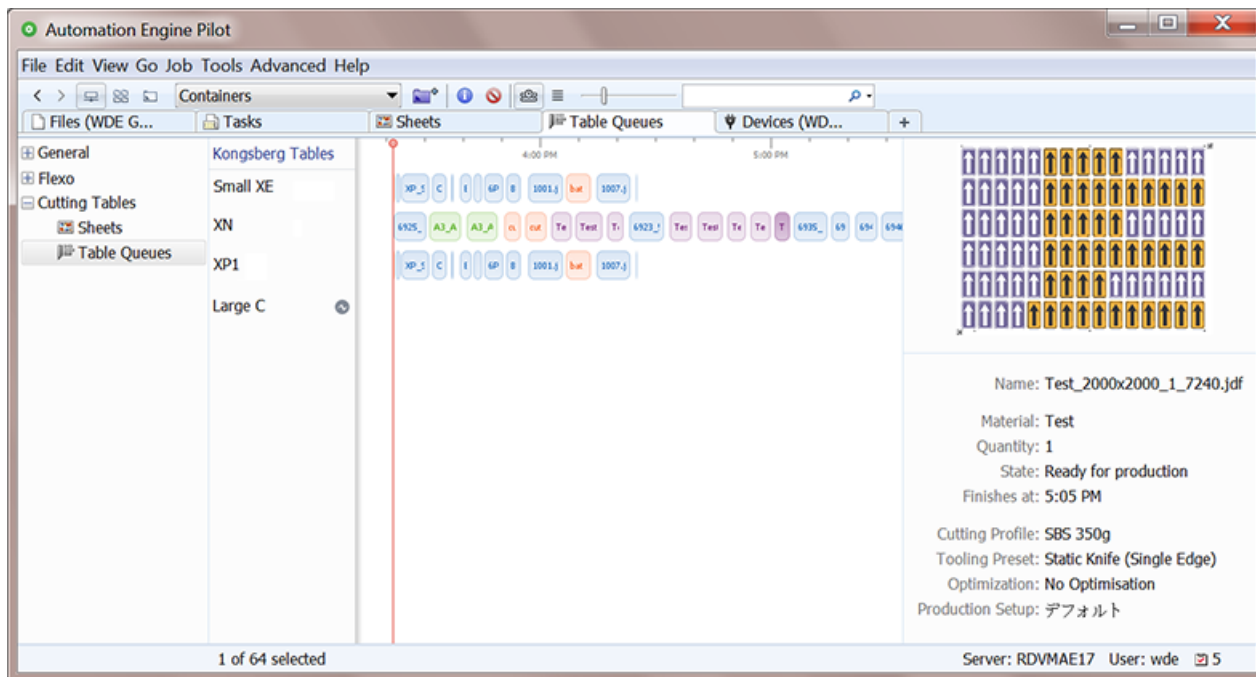

**Time Line View**

- The red vertical line represents the current time. After selecting an entry, you can use your keyboard's arrow buttons to pan over the time axis to see details of the other scheduled jobs in that queue.
- When a job is being processed on the table, the time line view shows that job entry moving gradually to the left of the red line. When the job is completely produced on the table, the entry will have moved completely to the left side and disappear from this view once the iPC operator closes the job (confirms that all copies have been produced).
- The default color of a job entry is blue. Learn about conditional coloring below.
- The size of a job entry reflects the job's estimated duration. iPC can only deliver this info when the job is **Ready for production**. Learn about the different statuses below.

When an iPC operator still needs to prepare that job in iPC, its estimated duration is not available yet. It is then shown with a default width (corresponding to 10 minutes) and filled with a striped pattern. See this example where the entry on the right is not ready yet:

- Use the slider to increase or decrease the size of the queue entries.
- The space between each entry reflect the setup estimation time as configured on that iPC (**Edit > Options > Estimation**).

- When you use the filter, the jobs that don't match the search criteria are dimmed.
- When the iPC operator starts a job that was not shown as the first one in this (and his) queue, then that job automatically re-positions itself to the front of the queue.

-  **List View**

This view makes it easier to read details and to sort entries before selecting them. Most of the information is retrieved from iPC.









**Note:** As in many views in the Pilot, you can

- re-arrange columns by dragging their title to a new position
- sort them by clicking on a column title
- right-click a column title and choose to **Hide** this one or any other. In the list that appears, select **Select Columns...** if you want to change or re-arrange multiple items.
- use filters and optionally save them as a [Smart View](#).
- define your preferred unit in **Edit > Preferences > Units**.

The shown units follow the choice you made for this Pilot in **Edit > Preferences > Units**.

Possible statuses:

-  **Waiting for verification:** This is shown when status in iPC is "Pending for estimation" or "Check if ready for production". \*
-  **Not ready for production:** For example the job was submitted but iPC could not determine the cutting line in the PDF because it was set in the wrong spot color.
-  **Ready for production:** In the queue to be produced.
-  **Started:** Being produced.
-  **Paused:** For example because a new sheet is needed before continuing the job.
-  **Suspended:** The job was not (completely) done yet, but another job will be produced first.

### Conditional Coloring





In Time Line view, coloring the entries helps to get a quicker understanding of the queues. You could for example set a color per type of **Material** or per **Tooling Preset**. See an example in above screenshot.

Follow these steps to color entries (for all available Kongsberg tables):

- Right-click the name of any of the tables and choose **Conditional Coloring**.
- **Add** one or more rules.
- Use **Move up/down** to control the order in which they are executed. For example, when the first rule colors some entries red, then the second rule can only affect the other entries, etc.

### Deleting, Moving and Splitting Jobs



**Tip:** Selections that you make remain active when you switch the  /  view modes. An example: In the  List view mode, sort per column and then make a multiple selection. Then switch to the  Time Line view mode where the selection is kept and then move the selected entries to the front of the queue.



**Attention:** There is no 'undo' for any of these functions.



**Note:** When making these changes, both the related Views in the Pilot and the list of jobs on the respective iPC stations update automatically.



**Tip:** You can also execute below mentioned actions on selections that you made with the filter. When entering a search text in the filter, the search is done on the job's **Name** and **Material**.

- **Deleting Jobs.** Select and press **Delete** (or right-click and choose **Delete**) to delete jobs from the queue. This also deletes them from the iPC job list. You will be asked to confirm.



**Note:** When a job is open in iPC, it cannot be removed.

In the *Sheets view*, the deleted jobs will show up as  **Aborted**.

- **Moving a job to a different position in the same queue.** You can re-arrange the queue by using drag and drop, even on multiple selected jobs. This also updates their order in the iPC jobs list.

To move a job to the front of the queue, right-click the job and choose **Cut Next**.

- **Moving a job to a different queue.** When a table needs to undergo maintenance, or when you manually want to balance the production load, you can drag and drop one or multiple queue entries to another table queue.



**Note:** When a job is open in iPC, it cannot be moved to another queue.



**Note:** This function requires an iPC version higher than 2.0.

- **Splitting a Job.** Another way to manually balance the workload of your tables, is to split a job. A job that requires a large number of sheets to be produced, can so be spread over multiple tables.

Follow these steps:

1. In the queue (both in List or in Time Line view), right-click a job and choose **Split Job...**
2. The **Split Job** dialog opens. By default, the job will be split in two parts each having half of the total number of copies.
  - Click **+** to split into more parts.
  - Click **-** to remove the selected part.
  - Slide the **resize control** (the small circle) to the left or right to modify the number of copies of those parts.
  - Enter the number of **Copies** in the edit field. Press 'Tab' to confirm the value. Press 'Enter' to **Split** the job and close the dialog.

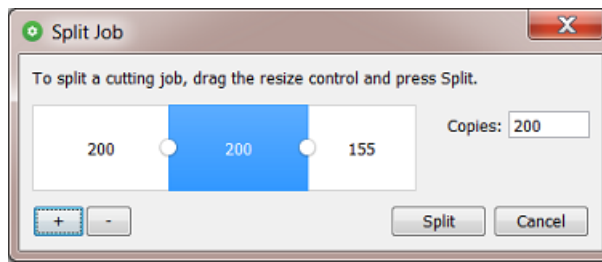

3. Click **Split** to confirm and close the dialog.



**Note:** When a job is open in iPC, it cannot be split.

### 18.2.3. Sheets

#### Concept

The Sheets view gives a historical overview of all jobs that were produced on your Kongsberg tables. It shows all closed jobs in iPC, both those successfully finished and those aborted during cutting.

Each sheet is a row. Each entry gives information about a cutting job and how it was processed on the table: start and finish time, number of copies produced, table name etc.

This view does not do live updates. To see updates of newly finished jobs, refresh the view via **View > Refresh** or press **F5** or **CMD-R**.

When a table was offline when it finished a job, the sheet entry will show up in this view once the connection has been restored.

Entries in this view are cleaned up automatically according to the rule set in the [Configure tool item for Devices database](#).

The details pane on the right shows a preview and some key properties of the selected sheet (drag its left edge to enlarge it).

The bottom bar indicates how many sheets there are (total or selected or filtered).

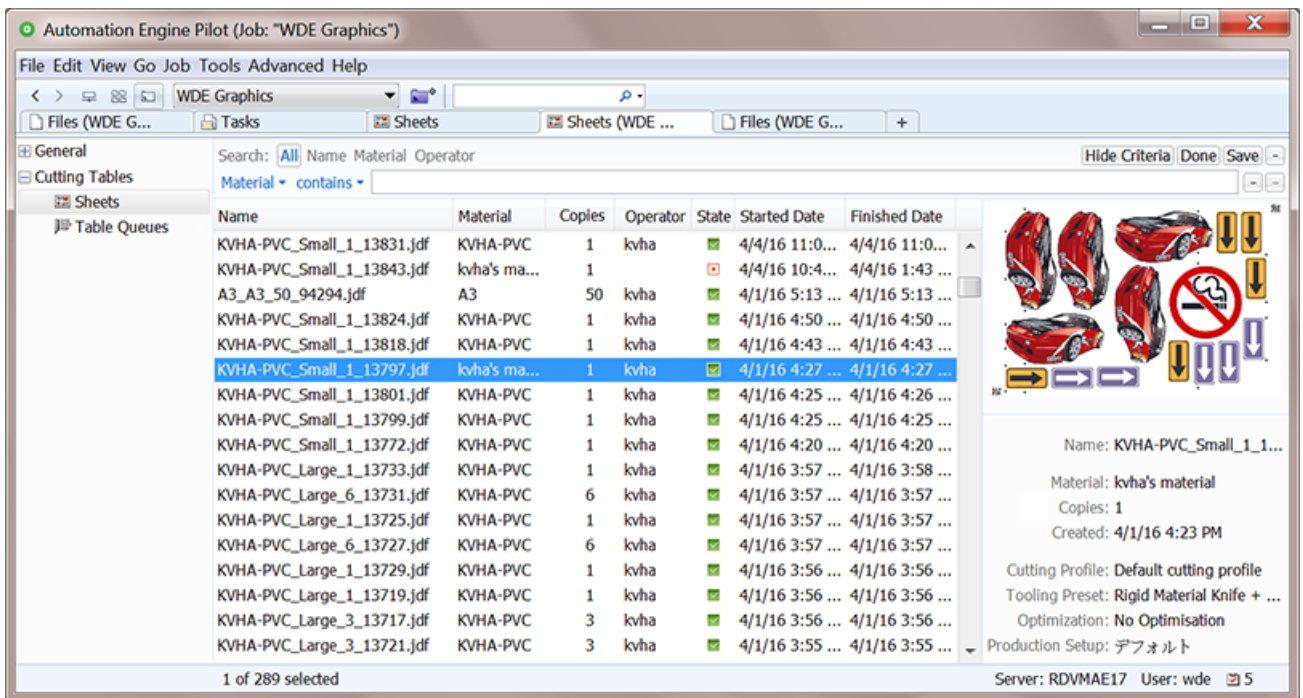

**Note:** As in many views in the Pilot, you can

- re-arrange columns by dragging their title to a new position
- sort them by clicking on a column title
- right-click a column title and choose to **Hide** this one or any other. In the list that appears, select **Select Columns...** if you want to change or re-arrange multiple items.
- use filters and optionally save them as a *Smart View*.
- define your preferred unit in **Edit > Preferences > Units**.

### Columns

- **Name.** This is the name of the cutting job.



**Note:** When the name ends with `.jdf`, this means that this job was created by the *Submit to Kongsberg table* task. Otherwise (where the name ends with `.acm`, `.cut`, `.ard...`), this means that the job was manually added to iPC's My Jobs list or that a job entered by the task was changed in iPC before being produced.

- **Customer:** When the sheet was created via a gang run queue that received a Customer ID when files were submitted, then the corresponding customer name is used. When an ARD or MFG was directly submitted to a Kongsberg table, the customer name is extracted from the information inside the ARD or MFG file.
- **Customer ID:** This is the ID that was specified in the *Submit to Gang Run task*. When jobs with different customer IDs are nested on one sheet, the sheet's customer ID will be a concatenation of all customer IDs.
- **State:** Final state of the job:  finished or  aborted.

- **Operator:** IPC user who started the job.
- **Table Name:** Name of the device on which the job was produced.
- **Material:** Name of the material used to produce the job.
- **Copies:** Total requested number of copies for this sheet/layout (as specified in the '[Submit to Kongsberg table](#)' ticket or as set in iPC).



**Note:** *This example of a workflow using Gang Run* helps to understand the difference between quantities and copies.

- **Copies Produced:** Number of successfully produced copies of this sheet/layout.
- **Copies Rejected:** Number of unsuccessful copies while producing this job.
- **Estimated Duration:** Estimated time to produce all copies of the job.
- **Created Date:** Time/date when the job was submitted in the table queue (ISO 8601 UTC).
- **Started Date:** Time/date when the table started cutting.
- **Finished Date:** Time/date when the job was finished or aborted.
- **Media Height / Width:** Height and width of the used sheet.
  - When the job was submitted to iPC by Automation Engine, then this is the media size as specified in the submitted JDF (the sheet size of gang run layouts, the sheet size from submitted MFG files, the blank size of submitted ARD files)
  - When the job was added by iPC, then iPC sets the media size.
- **Mapping Preset:** Used to import the job on iPC.
- **Optimization, Cutting Profile, Production Setup, Tooling Preset:** Attributes used to produce the job.

### Launching Tasks

When you right-click an entry, you can choose to launch a **New Task** on that entry.

- When you want to produce a sheet again, choose the [Submit to Kongsberg task](#) and define its options. Choose "**From Input File**" when you want a value to be taken from the input JDF, it will then be the same as the value used before.
- The [Export Kongsberg Cutting History task](#) does not base the data it exports on the entry that you selected but only on the options that you set in the ticket. This task does require an input file however, but does not use it for its output. This also means that there is no need to launch this task from this view.
- Choose **Other...** to launch another task type. Once you have launched it, this task type then also appears in the initial list.



**Attention:** These tasks, with exception of the [Export Kongsberg Cutting History task](#), use the sheet's JDF file as input file (even when the sheet Name mentions another file format). These JDF files are present in the **Media Root Folder** as defined in the [Configure tool item for Device Databases..](#)

## 18.2.4. Orders

The Orders view is part of the Views category **Sign & Display**. This view is documented in the chapter on [Sign & Display Workflow](#) on page 953. Find a direct link [here](#).



## 18.3. Kongsberg Related Tasks

---

### 18.3.1. Submit To Kongsberg Table task

#### Concept

This task submits the input file to the **My Jobs** list of the chosen iPC (Kongsberg table). This also creates an entry for this iPC job in the [Table Queues view](#).



**Note:** This page is part of a [separate chapter on using Automation Engine in a Kongsberg table workflow](#). We advise to first learn about its concepts and workflow types in this [intro](#).

In iPC, the order of the submitted jobs is decided by the priority of this task, as was selected in the ticket: **Low**, **Normal**, **High** or **Immediate**. Submitted jobs with a same priority are in iPC sorted by their due date.

#### Input File Types

- **ARD or MFG files.** One iPC job is created per input file. The task wraps the ARD or MFG in a JDF file before sending it to the iPC. Learn more about this workflow in [Submitting Single CAD Files](#) on page 1566.



**Note:** The media size of the JDF is set to the sheet size of the MFG file or to the bounding box of all cut lines of the ARD file.

When available, the board description, grain direction and customer info is read from the ARD or MFG file and used in the iPC job.

Also **PDF files** will be wrapped in a JDF and sent to the iPC.

- **JDF for digital cutting.** This type of JDF file is created in these two cases:
  - By the **Export Gang Run Layouts** task (used in the [workflow started by a Gang Run Substrate queue](#)).
  - Or by resubmitting a cutting job from the [Sheets view](#).
- **XML cutting request.** This file is created by the CDI Plate Merger and describes how the flexo plate should be cut. [Automation Engine's workflow for CDI Imagers](#) can submit such an XML to the Kongsberg table at the moment it is informed that the CDI plate was imaged. Learn more in [Cutting CDI plates](#) on page 1568.

#### Settings

- **Kongsberg Table:** Select a table (iPC) from the list of [devices](#) that you configured earlier.



**Note:** The submitted job will also enter the queue even when the selected table is offline at that moment (see its status in [Device view](#)).

- **Kongsberg Job Name:** Define the name of the job as it will appear in the **My Jobs** list of the chosen iPC.

- **Due Date:** You can set a due date for the job. This time will then be mentioned for that job in iPC. You can choose an absolute or relative time.

When you select a due date "**From Input File**":

- When the input file is an ARD or MFG, or when the task is started from the [Sheets view](#), then the job is submitted without due date.
- Otherwise the value from the input JDF file is used (the cutting file type "JDF for Kongsberg" created by the [Export Gang Run Layouts task](#)).



**Note:** A due date specified by a SmartName must resolve to a valid ISO 8601 string, i.e. the format `yyyy-mm-ddTth:mm:ss`. For example `2017-03-10T10:00:00`.

- **Copies:** Define the number of sheets to cut. When you keep the default "**From Input File**", this number will be taken from the input file's attributes. When no such information is available, the amount will be 1.



**Note:** When the task is started by resubmitting it from the [Sheets view](#), "**From Input File**" then re-uses the previously used value (as present in the input JDF file).

- **Material, Mapping Preset and Cutting Profile:** Click  to select the wanted resource from the list. This list is automatically updated with the resources you created in iPC.



**Note:** When you here type in the name of a resource that does not exist, it will show up in iPC's **Job Info** with this warning icon: .



**Note:** Any changes that you do in iPC to a Job's resources are communicated to Automation Engine. The updated settings automatically show up in the [Sheets](#) and [Table Queues](#) views.

### 18.3.2. Export Kongsberg Cutting History

#### Concept

This task exports information about finished cutting jobs to an XML file. External systems can use these XML reports to get job status information or calculate production statistics.



**Note:** This task needs an input file. However, the only use of this input file is to resolve the SmartName `[File]` in the setting **File Name**.

You can launch this task manually or as part of a workflow. An external system can decide to launch it itself by using a [Web Service Access Point](#).



**Note:** The task always runs outside of a Job context, even when launched from within an Automation Engine Job.

#### Settings

- **Output in:** When no folder is specified, the file is written in the root folder of the `ExampleJobContainer`.
- **File Name:** Use SmartNames to define the name of the output XML. When that XML already exists, it is overwritten and the task ends with a warning.

- [File] results in the name of the task's input file.
- [File Number] is relevant when you use the advanced option **Records per File** (see below).
- In **Export history records that match the following criteria**, create one or multiple rules that specify which kind of data should be exported.

This filter tool is the same as used to create view filters in many places in the Pilot. See an example on filtering [here](#).

- **Advanced...** These options define the structure of the XML.
  - **Columns:** Click on  to select which columns you want to export into the XML file. By default, all columns are exported.



**Note:** When using a SmartName, it needs to resolve to the internal name(s) of the column(s). To find these internal names, right-click in the **Columns** field, choose **Copy Parameter Value** and paste this in a text file.

- **Sort By:** Select a column type by which you want to sort the jobs.
- **Order:** Select the order of the columns.
- **Records per File:** Define the maximum of records that the XML file may contain. When there are more records than that number, extra XML files are created and they get an extra number at the end of their name (using the SmartName [File Number]).

## Example

```

<?xml version="1.0" encoding="UTF-8" ?>
- <!--
  Generated by Automation Engine 16.0.0 ALPHA - Build 622 - Mar 23 2016
  on host RDVMAE17 at 2016-03-24T15:28:04.458Z
-->
- <CutJobs>
- <CutJob>
  <Operator>Administrator</Operator>
  <Status>FINISHED</Status>
  <CreationDate>2016-03-08T13:39:15.773Z</CreationDate>
  <AmountProduced>1</AmountProduced>
  <Optimisation>SampleMaking</Optimisation>
  <Amount>1</Amount>
  <ProductID>Test</ProductID>
  <Mapping>Default mapping</Mapping>
  <FinishDate>2016-03-21T07:38:16.018Z</FinishDate>
  <CuttingProfile>SBS 350g</CuttingProfile>
  <Name>Test_2000x2000_1_7322.jdf</Name>
  <StartDate>2016-03-21T07:38:04.627Z</StartDate>
  <TableName>rdvmae14</TableName>
  <EstimatedCuttingTime>587</EstimatedCuttingTime>
  <ToolingPreset>Rigid Material Knife + Crease</ToolingPreset>
  <IDFields><?xml version="1.0" encoding="UTF-8"?><IdentificationFields></IdentificationFields></IDFields>
  <JobPartID>AmericanCars-Test_2000x2000_1_7322</JobPartID>
  <MediaY>2000.0</MediaY>
  <MediaX>2000.0</MediaX>
  <ProductionSetup>Multi-zone</ProductionSetup>
  <EstimatedBeforeFirstCopy>29</EstimatedBeforeFirstCopy>
  <ID>57821cfe-ef3b-4a5f-a634-9b3712df0ae6</ID>
  <JobID>AmericanCars</JobID>
  <EstimatedAfterLastCopy>58</EstimatedAfterLastCopy>
</CutJob>
+ <CutJob>
+ <CutJob>
+ <CutJob>
...

```



**Note:** Dates and times are described in the format of ISO 8601 (YYYY-MM-DDThh:mm:ssTZD).



**Note:** The elements **JobID**, **JobPartID** and **ProductID** do not relate to Automation Engine's Job or Product concepts, but to terminology in iPC.

## 18.4. Workflow Example

This example helps to clarify terms like quantity, copies, layouts, order, JDF and sheets.

We here illustrate a workflow where the Gang Run mode creates layouts of what needs to be printed and where the printed sheets are then cut on a Kongsberg table.



**Note:** This example workflow does not include steps like creating an Automation Engine Job, arrival and preflighting of the graphics, an approval stage nor feedback to a business system.

Each step provides links to pages describing the used features.

### 18.4.1. Step 1 - The Order

Your sales department confirms a production order for 50 large Esko logos on thick PVC material. A PDF was delivered with a correct trim box. The PDF is small and needs to be printed 10 times bigger.



### 18.4.2. Step 2a - Submitting the PDF to the Gang Run

The PDF with the Esko logo is submitted to a gang run queue, requesting a **Quantity** of "50". The Orders view immediately shows this new entry.

These steps are needed:

1. [Create a substrate queue](#) for the requested PVC material. Add available sizes and define its nesting settings.
2. Create the queue's output workflow. You minimally need these steps and options:



- In the [Export Gang Run Layouts](#) step, set the option **Save Cutting Files** to "**JDF File (Kongsberg)**".
  - The output pin for the cutting files continues to the Submit to Kongsberg Table step.
  - In the [Submit to Kongsberg Table](#) step, make sure you keep the option **Copies** to "**From Input File**".
3. [Attach the created workflow](#) to the substrate queue.
  4. In Files view, select the PDF and open a [Submit to Gang Run](#) ticket.



- Define a **Quantity** of 50 and **Scale** the file to 1000%. Request that the cut path will be created from the file's trim box.

Settings for Step: Submit to Gang Run

General Back Substrate Extra

Quantity: 50

Maximum Fill

Scale: 1000%

Rotation: Set by Substrate Queue

Cut Path from Ink:

A comma separated list of ink names.  
The first matching ink will be used to create a cut path.

If no ink is found  Create cut path from CAD object or trim box

Due Date: Today at 12:00 AM

- In the [Extra](#) tab, enter a logic **Order ID**.
5. Launch the **Submit to Gang Run** task.

### 18.4.3. Step 2b - First Appearance in the Orders View

As soon as the PDF is submitted to a substrate queue, a new item appears in the Orders view. This initial status shows that all of the requested quantity is still "In Gang Run".

Layouts are usually calculated quickly, after which the status changes again, which is why this status is only visible briefly.

Orders

In Gang Run  
100%

Order ID: 1106 Esko logo  
Quantity: 50  
Customer Name: 0012  
Due Date: 5/11/16 12:00 AM

+ In Gang Run: 1 →

+ One-Ups: 1

+ Layouts: 0

### 18.4.4. Step 3 - Quantity vs. Layouts

In our example that requests a **Quantity** of 50 logos, the substrate queue decides, based on its substrate sheet size, to create 2 **Layouts**:

- 1 layout PDFPLA file with 8 logos, representing the sheet that needs to be printed 6 times (totaling 48 logos).



- 1 layout PDFPLA file with the remaining 2 logos, representing the sheet that needs to be printed 1 time.





### 18.4.5. Step 4 - Files Created

The output workflow of the substrate queue starts with creating the files that are needed to print and to cut this order.

The Export Gang Run Layouts task creates:

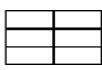
- 2 PDF files (one with 8 logos and one with 2 logos)
- 2 JDF files and 2 cutting files. Each JDF includes a reference to its own cutting file:

-  one describes how to cut a sheet with 8 logos

-  one describes how to cut a sheet with 2 logos.

In the Orders view, you can see the new status "in Output Workflow" and the names of the created files:

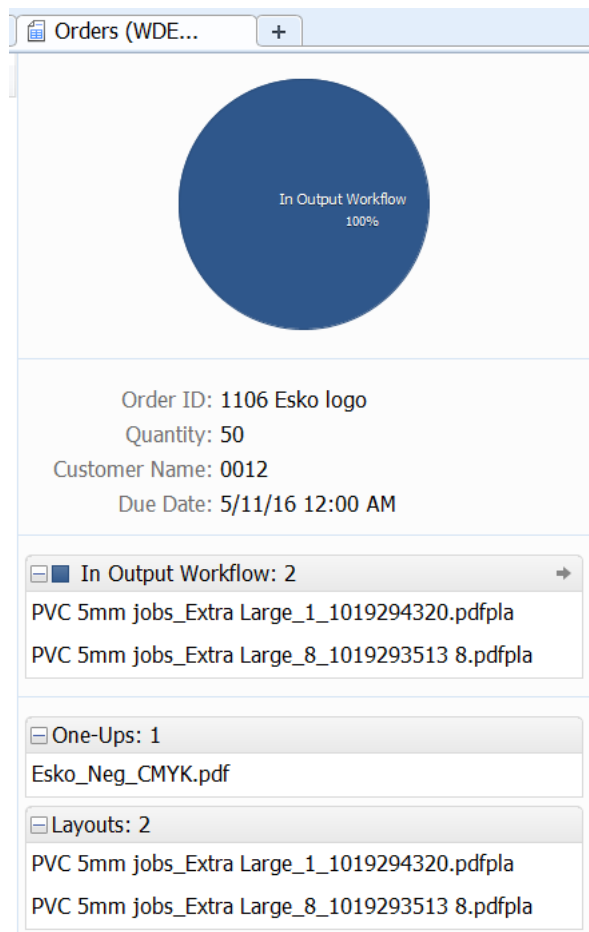

### 18.4.6. Step 5 - Each JDF is a Job entry in the Table Queues view

A JDF (Job Definition Format) file describes what needs to happen and also assures the bidirectional communication between Automation Engine and the iPC.

The output workflow ends by submitting the 2 JDF files to the Kongsberg table.

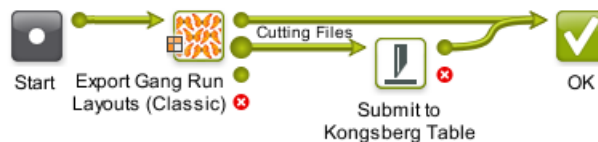

Two job entries immediately appear in the [Table Queues](#) view.

In below screenshot, see how one job entry looks much larger than the other. The selected entry needs to cut 8 copies of the PVC "sheet" containing 6 logos and will therefore take much longer to produce than the other one:



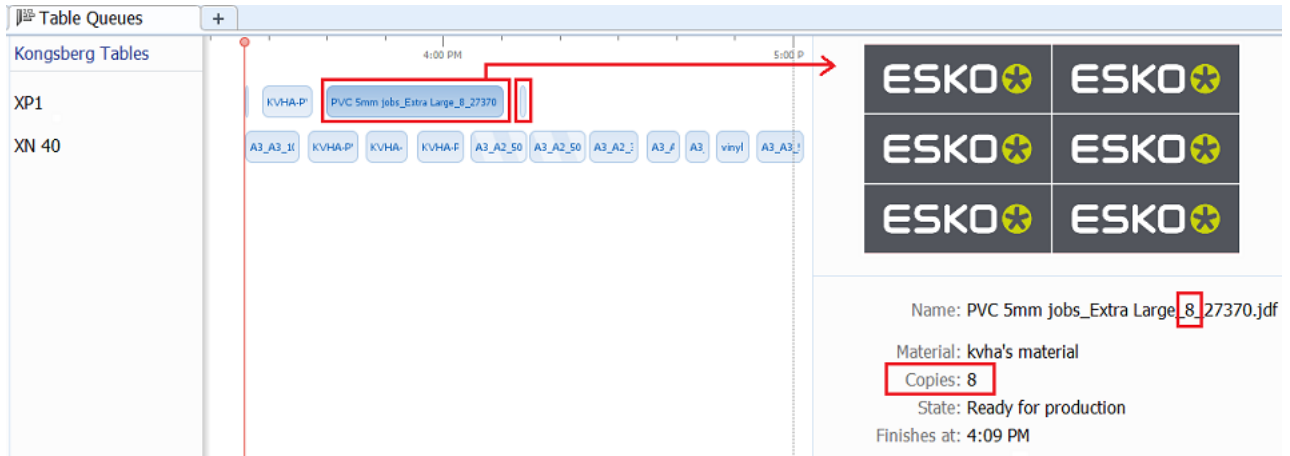

### 18.4.7. Step 6 - Logos are Printed and Moved to the Table

The 2 print PDF files created by the Export Gang Run Layouts task are printed.

The 9 sheets (8 copies and 1 copy) are made available near the Kongsberg table.

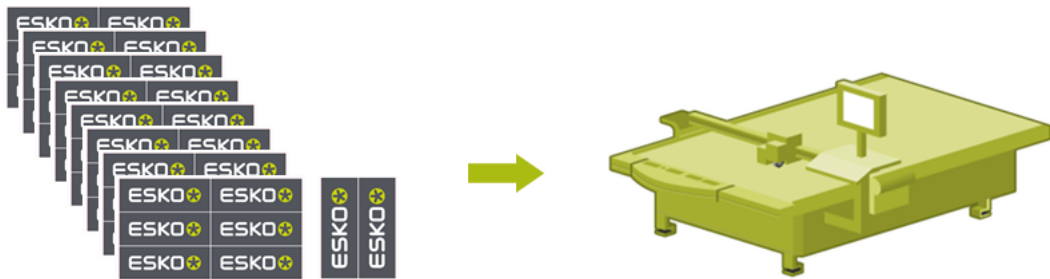

### 18.4.8. Step 7 - The iPC Operator Produces the Jobs

The iPC operator places the printed PVC sheet on the table and starts the matching cutting job for that type of sheet.



### 18.4.9. Step 8 - The Sheets View shows the Production Results

When the iPC has finished producing a job, this job appears in the Sheets view.

In below screenshot, the Sheets view shows that both jobs were produced and also shows how many copies of that type of sheet were produced.

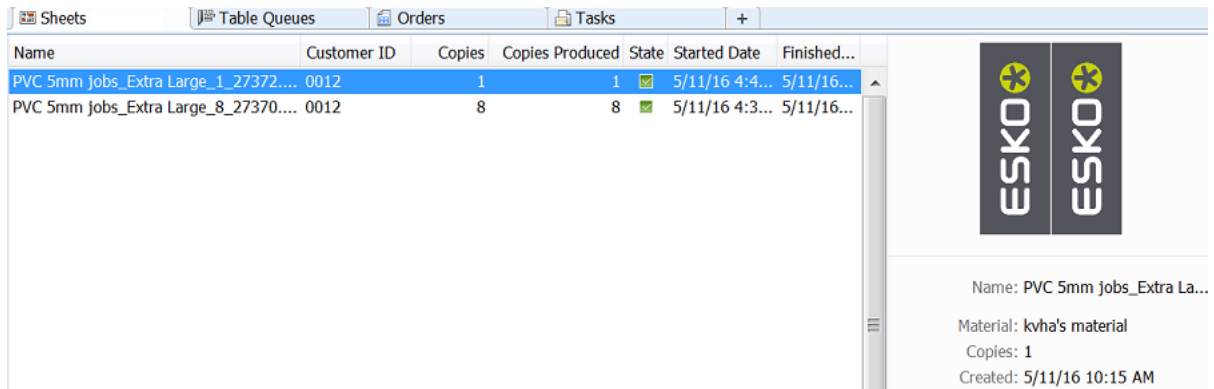

Name	Customer ID	Copies	Copies Produced	State	Started Date	Finished...
PVC 5mm jobs_Extra Large_1_27372....	0012	1	1	<input checked="" type="checkbox"/>	5/11/16 4:4...	5/11/16...
PVC 5mm jobs_Extra Large_8_27370....	0012	8	8	<input checked="" type="checkbox"/>	5/11/16 4:3...	5/11/16...



Name: PVC 5mm jobs\_Extra La...

Material: kvha's material

Copies: 1

Created: 5/11/16 10:15 AM

# 19. Digital Printing Workflow

## 19.1. Intro

'DFE' stands for 'Digital Front End', the application that manages, feeds and monitors a Digital Press.

Three types of DFEs are supported:

- **Esko DFE:** A DFE created by Esko and used in 3rd party press vendors.
- **HP Production Pro:** A DFE created by HP.
- **Generic DFE.** A non-Esko DFE that follows the JDF integration that Esko has defined, technically this is the 'worker' side of *Integrated Digital Printing ICS*. For example the DFE of a Bobst press.

Automation Engine typically sends print-ready layouts to a DFE, including layouts with Variable Data (VDP).

Once you have created a *Device* for such a digital press in the Pilot's Device view, you can start using the corresponding "Submit to ..." tasks.

## 19.2. Devices (Digital Presses)



**Attention:** Before 16.1, Automation Engine already offered the *Print on Digital Press task* to print to a digital press. That task has similar functionality but does not use the Devices view. The type of press and version of the DFE decide if that task or any of the "Submit to ..." tasks can be used..



**Tip:** The **Devices** view can also be opened as a Tool: Go to **Tools > Devices** to monitor and manage your devices in a separate window.

### Adding a Digital Press Device

Follow these steps to add a Digital Press device:

1. In Devices view, click on .
2. Select the type of DFE the press is using: **Esko DFE**, **Generic DFE** or **HP Production Pro**.



**Note:** Adding a Generic DFE device requires a prior manual registration. Read more below in a dedicated section.

3. Enter the name of the **Server** computer that this DFE is installed on and click **Continue**.
4. A list appears with one or multiple DFEs. Select the one you want and click **Add**.

The status box of the newly created device appears.

**Information and Functionality**

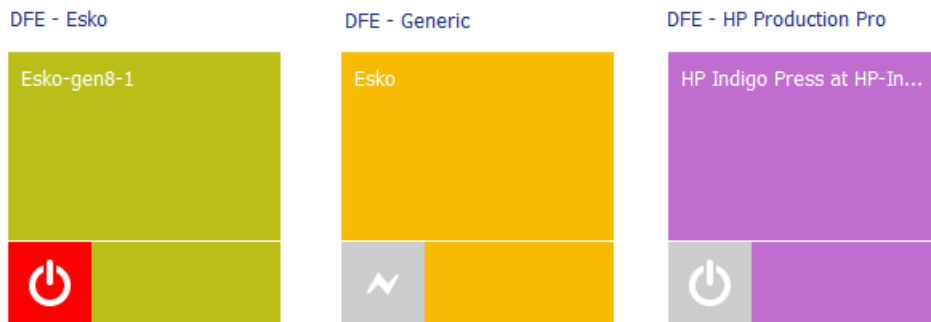

The device status box shows following information that it receives from that DFE:

- The **name of the device**. By default this is the name of the computer where the DFE was detected.
- A **device status icon**.

In below info on status, the term DFE is valid for all 3 types of DFE devices:

- : The press is **idle**. The DFE is online, but the press is not producing (not printing).
- : The DFE is online but the press is stopped or down.
- : Retrieving the status of the DFE.
- : The DFE is **offline**. The device's computer is shut down or there is a network issue preventing a connection to the DFE.
- : The press is producing (printing).
- : The press is paused.

Right-click a status box to choose one of these options:

- **New Device....** An alternative to clicking .
- **Delete** (or press ). You will be asked to confirm.
- **Rename**.
- **Info** (or press or double-click). This dialog shows details about the device (version, settings, etc.). You can add a **Description** to help identify this device. Click **Advanced Options** for a detailed technical list of its parameters.

**Registration and Adding of a Generic DFE device - PRE-RELEASE in 23.11)**

- **Manual Registration:** In this version of Automation Engine, before you can add the generic DFE in the Pilot's Devices view, Esko's team that assists with 3rd party integrations will help you to first execute these steps:
  1. On the AE server computer, go to `Esko/bg_data_fastserver_v100/`.
  2. Create a subfolder `/gendfe`.
  3. Put the XML file in there that describes the deviations and custom extensions of this DFE.

An example of an XML with the required formatting for a Bobst press:

```
<GenericDeviceFamily>
  <ResourceQueries>
    <Resource>
      <Name>PrintJobPreset</Name>
      <JDFResourceName>eg:PrintJobTicket</JDFResourceName>
      <JDFResourceClass>Parameter</JDFResourceClass>
    </Resource>
    <Resource>
      <Name>Media</Name>
      <JDFResourceName>Media</JDFResourceName>
      <JDFResourceClass>Consumable</JDFResourceClass>
    </Resource>
  </ResourceQueries>
</GenericDeviceFamily>
```

- **Pilot: Adding the Device:**

In the Pilot's Devices view, click on  and select the type **DFE - Generic**.

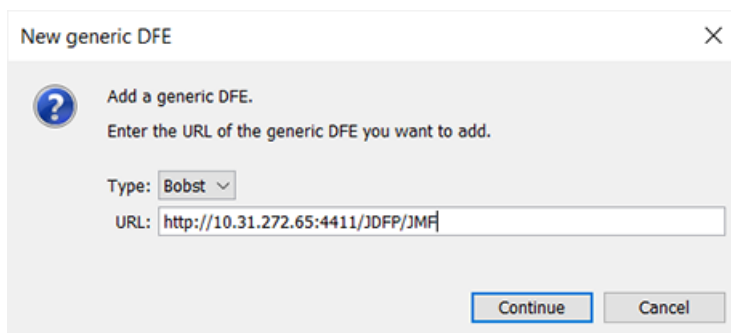

- **Type:** This list shows the above described XML file(s) present in `Esko/bg_data_fastserver_v100/gendfe`. Select one (the list shows the XML file name(s)).
- **URL:** Specify the URL to the JMF server of the generic DFE.
- Click **Continue**. The resulting device icon will show the Device Name (not the XML file name).

## 19.3. Tasks related to Digital Printing

### 19.3.1. Convert Colors for Digital Printing (Classic)

You can use this task to convert PDF files' colors before sending them to your digital press.

It takes both PDF and Normalized PDF files as input. When working with regular PDFs, it will automatically normalize them using the **Normalize ticket** that is selected in the **Configure** tool's [Processing Preferences](#).

This task keeps your file's metadata intact (for example CAD information).



**Tip:** We recommend you place this task towards the end of your workflow, as close to the output device as possible.



**Important:**

Make sure your Automation Engine server and your Digital Front End server are using the **same color database** (by default, they are each installed with their own color database).

This is needed to make sure you can use the same color strategy for converting your colors in Automation Engine and for printing your job in the DFE.

See [Using Shared Resources between Automation Engine and the DFE](#) for more information.

**Use Case**

You would typically use this task as follows:

1. Set up a digital printing color strategy in your Color Engine Pilot application (or ask your color expert to do this for you).

If desired, you can tweak that color strategy until it converts your spot colors exactly as you want it to (for example, you can add conversion exceptions for specific spot colors).

For more information about setting up a color strategy, see the Color Engine Pilot documentation that came with your Digital Front End software.

2. Then use your color strategy in this task to automate the conversion of all your file's variants or "SKUs" (Stock Keeping Units), for example for different languages, sizes, flavors...

**Parameters**

1. Select the **Color Strategy** you want to use for the conversion. This must be a **digital printing color strategy** created in the Color Engine Pilot application that came with your Digital Front End software.

Typically, your color strategy doesn't only contain general color conversion settings, but also color conversion exceptions, either for the spot colors you use the most, or for a whole Pantone book (see the Color Engine Pilot documentation that came with your Digital Front End software for more information about color strategy settings).

These exceptions determine the exact percentages of the available output inks that will be used to print the corresponding spot colors. These have often been adjusted by your color expert to give you the spot color simulation you want.

2. In **Undefined Spot Colors**, choose what to do when the file contains a spot color for which your color strategy has no exception.
  - Select **Do not convert (keep in output)** if you want to leave the spot color untouched in the output file. Do this for example if you are using certain spot colors as extra output inks (typically white or metallic inks).

In this case, the task will end in a warning.



**Tip:** Consider setting up your workflow so that:

- the output file gets sent to the next task automatically (if you are sure that those spot colors are extra output inks),
- further processing of the output file is paused, so that you can check whether those spot colors are actually extra output inks.

- Select **Convert** to convert that spot color to the color strategy's output profile using the strategy's general color conversion settings.

- Select **Generate error** if you don't want to convert the file at all, and instead have the task end in error.

Do this if you always make an exception for each spot color, so in this situation you want to stop the workflow and investigate why this is not the case. You may want to either replace the spot color in your file, or add an exception for that spot color in the color strategy.

3. Select **Flatten document** if you are experiencing unexpected color results when converting files containing overprints, transparencies or vignettes.

Flattening your file resolves its overprints and transparencies, and converts its vignettes to images.

In the example below, the original file contains three objects:

- the background (sky),
- the lighthouse, which is knocking out on the background object,
- the wave, which is overprinting on both the lighthouse object and the background object.

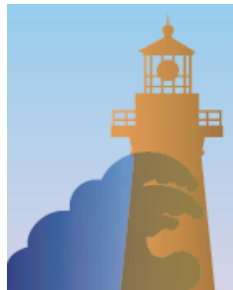

Flattening your file replaces the parts of objects that were overprinting or transparent by other objects. Those new objects have the color that was resulting from the overprint/transparency, but are not overprinting or transparent.





**Attention:** We recommend that you:

- flatten files with overprints, transparencies or vignettes,
- don't flatten files that you still need to trap or edit afterwards.

If you need to both flatten and trap your file, make sure to do your trapping first, and place the **Convert Colors for Digital Printing** task towards the end of your workflow, as close to the output device as possible.

## 19.3.2. Preflight Color for Digital Printing (Ink based)

### Concept

You can use this task to decide which ink set to use when sending a print job to your HP Indigo digital press.

Some print jobs can be printed just as well with less inks, so reducing the press's number of clicks and needed print time. However it is often cumbersome and time consuming to check this manually for every print job.

This task automates the checking and comparison process: it calculates the color accuracy you can achieve with the ink set(s) you plan to use, and so helps you choose a cost-effective solution that still meets your quality standards.



**Important:** This name of this task mentions "**(Ink based)**" because it checks the inks that are used in the input PDF file and then generates a table with information how they can be converted via selected strategy. This task does not check how or where these inks are used in this PDF file.

The related task [Preflight Color for Digital Printing \(Content based\)](#) has a different approach: it scans the PDF's actual data and can so give better info on how this particular file can be printed on digital press, all based on the selected strategy. This approach generates less numbers but they may be more relevant. This content based is the one used in ArtPro+, where it is named 'Digital Print Simulation'.

### Checking the Color Accuracy Achievable with a Certain Ink Set

If you want to check whether a certain file can be printed with a certain ink set and give a color accurate result:

1. Choose a color strategy made for printing with that ink set.
2. Set your color deviation tolerance (above which Delta E value you would consider the print not color accurate enough).
3. Send your file through the task.
4. The task outputs a detailed report: for each ink in your file needing conversion to your ink set, you can see the percentages of the inks on press that would be used, and whether the color accuracy would meet your tolerance.

Any ink that cannot be printed within your tolerance is given a "fail" status.

Your file only has an overall "pass" status if all its inks have a "pass" status. This means that you can print it color accurately with that ink set.

See [Task Parameters](#) on page 1595 for more information about setting up your task.



### Comparing the Color Accuracy Achievable with Different Ink Sets

You would typically run your file through several **Preflight Color for Digital Printing** tasks in a workflow: one task for each color strategy/ink set that you want to check.

Each task then outputs a report detailing the color accuracy you can achieve with that color strategy/ink set, and gives an overall "pass" or "fail" status for printing your file with that ink set.

This helps you can choose the smallest ink set that gives you a good color match for that file, so that you can combine quality and cost-efficiency.



**Note:** The detailed information in the reports helps you take an informed decision in difficult cases. The final decision always rests with you.

You can use this task:

- on the production floor, to help you maximize the speed and cost-efficiency of your digital press while still printing your jobs with good color accuracy.  
See [Preflight Color for Production](#) on page 1600.
- if you have a sales office, you can use it to help you quote a competitive price to your customers without skimping on quality (you can then pass on the ink set information to your prepress/printing department, saving them the time it would have taken them to check different ink sets).  
If your sales office uses an MIS system, you can even integrate a **Preflight Color for Digital Printing** workflow with your MIS system.  
See [Preflight Color for Cost Estimation](#) on page 1602.

### Task Parameters

Set up each task's parameters as follows:

1. Decide which ink set you want to check your file against, and select a **Color Strategy** whose output profile uses this ink set.  
Depending on whether you want to decide on an ink set for production or for cost estimation, the exact color strategy you choose may be different.  
See [Preflight Color for Production](#) on page 1600 and [Preflight Color for Cost Estimation](#) on page 1602.



**Attention:**

- You can only select a **digital printing color strategy**. If you select another type of color strategy (through a SmartName for example), the task will end in error.  
 You can create digital printing color strategies in Color Pilot (or in any older Color Engine Pilot 13.X version that came with your Digital Front End software).  
 See [the Color Pilot documentation](#) (or the Color Engine Pilot documentation that came with your Digital Front End software) for details.
- Make sure your Automation Engine Server and your Digital Front End server are using the **same color database** (by default, they are each installed with their own color database).  
 This is especially important for production, as you want to check your file against the exact color strategies you can use in the DFE to print it.  
 See [Using Shared Resources between Automation Engine and the DFE](#) for more information.
- The task will also end in error if it cannot find your chosen color strategy in the color database (if for example it was deleted before you ran the workflow).

2. Select the **Delta E Formula** to use to calculate the color difference between the spot colors in your file and how they can be reproduced using your chosen **Color Strategy**.

You can choose from:

- CIELAB Delta E,**
- Delta E 94,**
- Delta E 2000,**
- CMC (1:1),**
- CMC (2:1),**
- Delta E 2000 (2:1:1).**



**Note:** If your company is already using one of those formulas, we recommend that you choose the same one. If not, you should choose **Delta E 2000**, which is the best reflection of the visual difference between colors.

3. Choose how close (in Delta E) the output colors must be to the colors in your input file for you to accept the print job as color accurate, and enter this number in **Delta E Tolerance for Spot Colors**.

The default tolerance is 2 Delta E, as color deviations under this threshold are generally not visible to the human eye.

### Preflighting a File's Colors

You can send either PDF or Normalized PDFs files through this task. When working with regular PDFs, it will automatically normalize them using the **Normalize ticket** that is selected in the **Configure** tool's [Processing Preferences](#).

When running a file through this task:

1. The task calculates how to convert the file's separations to your chosen *Color Strategy's* output profile.

It checks all separations except:

separations that should be output as they are	<ul style="list-style-type: none"> <li>• process separations</li> <li>• other separations used in the output profile (when checking against a multicolor profile)</li> <li>• separations set to "Keep in Output" in the color strategy (for example White or metallics)</li> </ul>
separations that never require color management	<ul style="list-style-type: none"> <li>• technical separations</li> <li>• varnish separations</li> <li>• separations set to "Do Not Print" in the color strategy</li> </ul>
certain separations that have predefined conversion values set in the color strategy	separations converted through a conversion table <div style="border: 1px solid #ccc; padding: 5px; margin-top: 10px;">  <b>Note:</b> Other separations with conversion exception values in the color strategy (refined conversion values obtained with measurements or custom conversion values added manually) are checked.                 </div> <p>For more information about separation conversions values in color strategies, see <a href="#">the Color Pilot documentation</a>.</p>

2. For each separation, it checks whether the color difference between the converted color and the original color is within the *Delta E Tolerance* you have specified, and gives a **pass** or **fail** status.
3. It writes all of the **pass** or **fail** statuses for that file into an XML report, and gives an overall **pass** or **fail** status for that color strategy (**pass** means that the color difference is within your Delta E tolerance for all separations, but if at least one separation has a higher Delta E then the overall status is **fail**).

You can see the preflight results in the **Log Info** or the **XML report**. See [Color Preflight Results](#) on page 1598 for more information.

4. When running your file through several **Preflight Color for Digital Printing** tasks in a workflow, you can see which color strategies give a **pass**, and choose to use the smallest ink set that still gives you a good color reproduction.



**Note:**

- To see more details on the color reproduction of each color strategy, you can either check their XML reports manually or feed them to your MIS system.
- The final decision on what color strategy to use always rests with you.

If for example one of the color strategies gives you good Delta Es for all separations but one, and that separation is only present in a very small and less important area of your file, you can still decide to use that color strategy anyway.

If none of the ink sets/color strategies gives a good color reproduction, you may want to (depending on the case) use one or more additional spot colors, print the file with one of the color strategies anyway, tweak the color strategy in Color Pilot, adjust the file...

For more information about using several **Preflight Color for Digital Printing** tasks in a workflow, see:

- [Preflight Color for Cost Estimation](#) on page 1602
- [Preflight Color for Production](#) on page 1600

**Color Preflight Results**

**Processing Status**

- After running the **Preflight Color for Digital Printing** task on your input file, the **Tasks** pane shows the processing status (and not the preflight status).



Task status	Processing status
✔ <b>Successfully done</b>	Input file processed successfully (whether the Delta E values for the ink conversions are within your required tolerance or not)
⚠ <b>Done with warning</b>	Input file contains unregistered inks (inks that are not part of an ink book in your color database)
✖ <b>Failed</b>	The color strategy is invalid or doesn't exist

To see the preflight status (and detailed results), you should open the task's [Log Info](#), or the [XML report](#) it produced.

- When running the task in a **workflow**, the XML report is sent through a different output pin depending on both the processing status and the preflight status.

There are 5 output pins, corresponding to the following statuses:

Output pin	Processing status	Preflight status
● <b>Pass</b>	Input file processed successfully	With this color strategy, all conversions are within your Delta E tolerance
● <b>Fail</b>	Input file processed successfully	With this color strategy, at least one of the conversions gives a Delta E above your tolerance

Output pin	Processing status	Preflight status
 <b>Pass Unregistered</b>	Input file contains unregistered inks	All conversions are within your Delta E tolerance
 <b>Fail Unregistered</b>	Input file contains unregistered inks	At least one of the conversions gives a Delta E above your tolerance
 <b>Error</b>	The color strategy is invalid or doesn't exist	Cannot preflight

### Preflight Results Details in the Log

You can see the preflight results in detail in the task's [Log Info](#).

Retrieving ink list from input file...

Ink 1: process C)  
 Ink 2: process M)  
 Ink 3: process Y)  
 Ink 4: process K)  
 Ink 5: visualizer gloss spot UV varnish)  
 Ink 6: pms1000m Violet)  
 Ink 7: pmetc 10249)

Using color strategy 'ColorPreflight\_CMYKOV'  
 Using delta E formula 'CIELAB Delta E'  
 Using tolerance 2.0

Output inks:  
 Process cyan  
 Process magenta  
 Process yellow  
 Process black  
 ClassicColors Violet

Results:

Ink 1 is a process ink.(process C)  
 Ink 2 is a process ink.(process M)  
 Ink 3 is a process ink.(process Y)  
 Ink 4 is a process ink.(process K)  
 Ink 5 is a varnish ink. (visualizer gloss spot UV varnish)  
 Ink 6 is converted using the default conversion settings. Values = 0.0 6.7 0.0 16.9 0.0 0.0 89.8 (visualizer gloss spot UV varnish) Delta E = 0.2  
 Ink 7 is converted using the default conversion settings. Values = 82.4 0.0 0.0 32.9 0.0 0.0 80.0 (pms1000m Violet) Delta E = 0.2  
**PASS**

Under **Results**, it lists:

- which of the input file inks were converted by your chosen color strategy (*certain ink types* are never converted)



**Note:** If your input file contains a double strike of an ink (a percentage above 100%), this ink will appear twice.

- the conversion values for those inks (in percentages of the printing inks)
- the Delta E achieved for each converted ink
- the overall **PASS** or **FAIL** status



**Attention:** After running a workflow containing the **Preflight Color for Digital Printing** task, make sure you open the task's **Log Info** and not the workflow's **Log Info** (as the workflow's log only contains processing information).

### Preflight Results Details in the XML Report

Each **Preflight Color for Digital Printing** task also generates an XML report containing detailed results about the conversion to your chosen color strategy with your desired Delta E tolerance.

```
<?xml version="1.0" encoding="utf-8"?>
<CheckStrategy Strategy="ColorPreflight_CMYKOV" NumberOfInksUsed="5" OutputInksUsed="cyan;magenta;yellow;black;Violet"
Status="passed">
  <PassFailSettings DeltaEMetric="CIELAB Delta E" Tolerance="2"/>
  <SpotColorSet>
    <SpotColor InkName="C" InkBookName="process" status="IsProcessInk"/>
    <SpotColor InkName="M" InkBookName="process" status="IsProcessInk"/>
    <SpotColor InkName="Y" InkBookName="process" status="IsProcessInk"/>
    <SpotColor InkName="K" InkBookName="process" status="IsProcessInk"/>
    <SpotColor InkName="gloss spot UV varnish" InkBookName="Visualizer Standard Finishes" status="IsVarnish"/>
    <SpotColor InkName="Violet" InkBookName="PANTONE Colors Matte" DeviceColor="0.000 0.067 0.000 0.169 0.000
0.000 0.898" DeltaE="0.15" status="UsesDefaultConversionSettings"/>
    <SpotColor InkName="10249" InkBookName="PANTONE+ Premium Metallics Coated" DeviceColor="0.824 0.000 0.000
0.329 0.000 0.000 0.800" DeltaE="0.17" status="UsesDefaultConversionSettings"/>
  </SpotColorSet>
</CheckStrategy>
```

It contains the same information as the log, but is formatted to be easily usable by an MIS system (or Automation Engine's [Join XML Files](#) task, in preparation for sending to an MIS system).

If you are reading this XML report yourself:

- you can find the overall status at the top of the file (for example `Status="passed"`),
- you can check which of the input inks were converted (*ink types that are never converted* indicate the reason in their status, for example `Status="IsProcessInk"` or `Status="IsVarnish"`),
- for the inks that were converted, you can see the resulting percentages of the printing inks in `DeviceColor`, and the `Delta E` achieved.

### Preflight Color for Production

You can use the **Preflight Color for Digital Printing** task on the production floor, to help you maximize the speed and cost-efficiency of your digital press while still printing your jobs with good color accuracy.

When using this task to prepare for production, you want to decide on the ink set to use for your print job, but you may also want to take into account any tweaks necessary to get the best color result on your particular digital press.

This means that for each **Preflight Color for Digital Printing** task that you run on your file, you should select a [Color Strategy](#) using your digital press profile as an output profile.



**Tip:**

When profiling your digital press in Color Pilot, you can easily generate:

- a color strategy with your digital press profile as output profile,
- additional color strategies with a subset of that profile's ink set as output profile (for example, if you profiled your digital press with a CMYKOV ink set, you can also generate color strategies to output to CMYK, CMYKO and CMYKV on that press).

See [the Color Pilot documentation](#) for details.

### Example Workflow

One of the simplest ways to set up a workflow to check what ink set a file can be printed with is to cascade several **Preflight Color for Digital Printing** tasks.

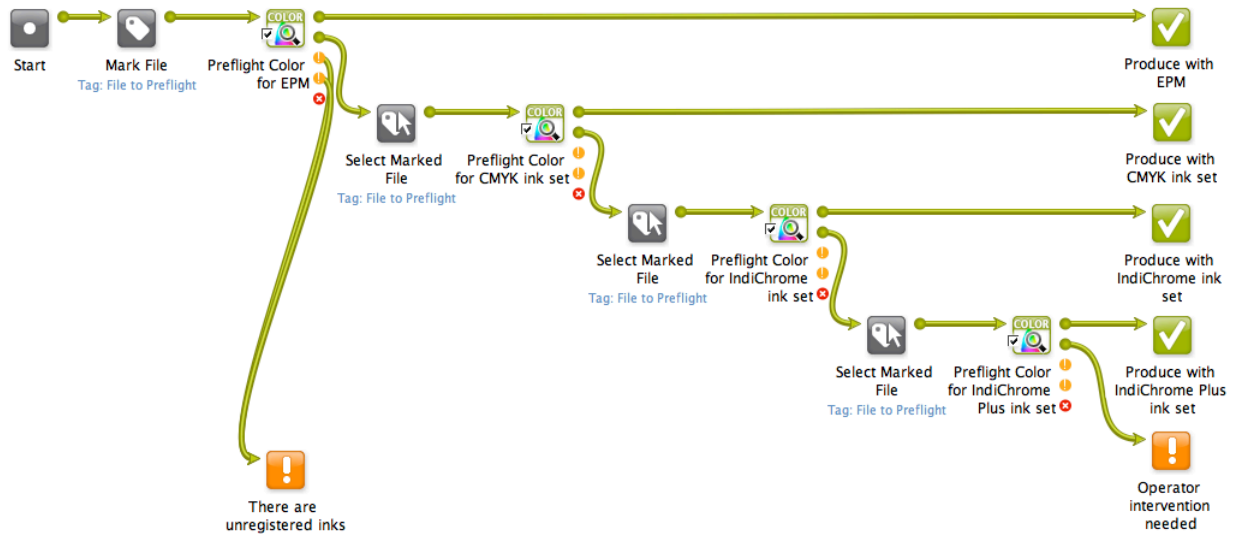

1. This workflow first marks the input file with a tag (File to Preflight) then sends it to the first **Preflight Color for Digital Printing** task.
2. This task checks whether printing the file with an EPM (CMY) color strategy would give a good color accuracy.



**Note:**

Make sure the color strategies you use in all your **Preflight Color for Digital Printing** tasks:

- are digital printing color strategies,
- use (one of) your digital press(es)'s profile as output profile.

For information about generating color strategies outputting to several ink sets from a digital press profile, see [the Color Pilot documentation](#).

The task outputs an XML report detailing the color accuracy that can be achieved.

- If printing the file with EPM would give good results, the report goes through the **Pass** output pin (the first green pin), and the workflow is finished.
- If EPM doesn't give a good color accuracy, the report goes through the **Fail** output pin (the second green pin), and the workflow continues.
- If your file contains one or more unregistered inks (inks that do not exist in your color database), it goes through one of the orange output pins (either **Pass Unregistered** or **Fail Unregistered** depending on the Delta E values).

In this case, the workflow ends with a warning (regardless of the Delta E values, the file isn't checked by any other **Preflight Color for Digital Printing** task).

- If the color strategy you have selected in your first **Preflight Color for Digital Printing** task doesn't exist (if for example it was deleted before you ran the workflow) or is not a digital printing color strategy, the report goes through the red **Error** output pin and the workflow ends with an error.
3. If the first color strategy (EPM) didn't give a good color accuracy, the XML report going through the second output pin triggers the **Select Marked File** workflow control.

This is set to select the input PDF/Normalized PDF corresponding to that XML report (using the `File to Preflight` tag and **Only select when name matches: [File]**).

See [Mark File and Select Marked File](#) on page 828 for more information.

4. That input PDF/Normalized PDF is then passed on to the next **Preflight Color for Digital Printing** task, that checks whether printing the file with a CMYK color strategy would give a good color accuracy.
5. If this is not the case, the file is checked against an IndiChrome (CMYKOV) color strategy, then if necessary an IndiChrome Plus (CMYKOGV) one.
6. If none of the ink sets/color strategies gives a good color reproduction, the workflow ends in a warning.

You can then check the different XML reports to help you make a decision about how to print your file.

Depending on the case, you may want to use one or more additional spot colors, print the file with one of the color strategies anyway, tweak the color strategy in Color Pilot, adjust the file...

### Preflight Color for Cost Estimation

You can use the **Preflight Color for Digital Printing** task at your sales office, to help you quote a competitive price to your customers without skimping on quality.

You can even connect it to your MIS system (for example CERM or Label Traxx), to get the print job information automatically, then send the color preflight results back to the MIS.

When using this task for cost estimation, the main goal is to decide on the ink set needed to print your job with a good color accuracy.

At that stage you don't need to worry about tweaking the print job to print on a specific press so you can use a [Color Strategy](#) with a generic output profile (for example `ISOcoated_V2_eci.icc` for the CMYK ink set).

### Example Workflow

There are many ways you can set up a workflow that checks what ink set a file can be printed with so you can quote a competitive price to your customers. For example, you can:

- Set up a cascading workflow that checks the file against each ink set, then check the workflow's results to choose the ink set to use (this is similar to the [production workflow](#), but here you can use generic color strategies with the right ink sets, instead of color strategies made for a specific digital press).
- Set up a workflow with one **Preflight Color for Digital Printing** task, where the color strategy and Delta E tolerance are public parameters, and enter all the color strategies you want to check as a semicolon-separated list (for example `CMY; CMYK; CMYKO; CMYKOV; CMYKOGV`). For each color strategy you specify, your file will go through the task and you will get an XML report.
- Set up a workflow that integrates with your MIS system, so that you can automatically launch the workflow on any file that comes into your MIS system for quotation, and get the results back into your MIS system (this way you can do this from your sales office without even needing to open the Automation Engine Pilot).

### Workflow with MIS Integration

This example workflow is set up to:

- take a PDF file,



- check it against a list of color strategies and a specific color tolerance (that are saved as [workflow parameters](#)),
- join all XML reports into one and save it in a location that your MIS system monitors,
- end in **OK** for the color strategies that can be used to print within the color tolerance, and in **Warning** for [all other cases](#).

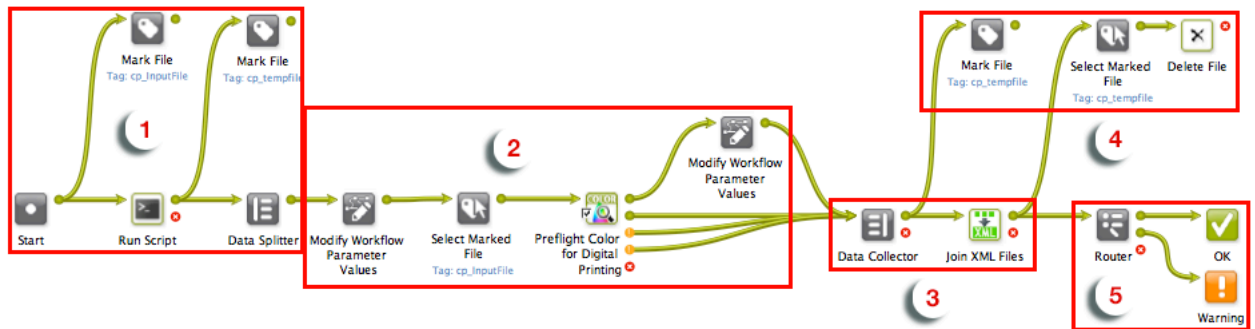

**1. Preparation**

The input file is paired with every color strategy that needs checking, and sent through the workflow as many times as there are color strategies.

- The input file is marked with the `cp_InputFile` tag so it can be picked up by the workflow later on.
- The **Run Script** task generates an XML file for each color strategy, containing the input file name and color strategy name. Those XML files are marked as `cp_tempfile`.
- The **Data Splitter** sends the XML files one by one to the rest of the workflow, where they will each trigger a color strategy check.

**2. Color Preflight**

For each input file/color strategy pair, the **Preflight Color for Digital Printing** task checks the color accuracy that can be achieved, and generates a detailed report.

For each XML file sent from the **Data Splitter**:

- The **Modify Workflow Parameter Values** workflow control picks up the color strategy name in the XML and saves it to the `SelectedStrategy` workflow parameter.
- The **Select Marked File** workflow control picks up the input file and sends it to the **Preflight Color for Digital Printing** task.
- The **Preflight Color for Digital Printing** task checks whether converting the input file with the current color strategy (from the `SelectedStrategy` workflow parameter) would give a Delta E within the required Delta E tolerance (from the `Tolerance` workflow parameter).

It outputs an XML report detailing the color accuracy that can be achieved with that color strategy, through the [appropriate output pin](#).

- If the file can be printed within the color tolerance using that color strategy, the `State` workflow parameter is set to `Pass`. Otherwise it is not changed.

**3. Reporting**

The **Data Collector** collects all XML reports and sends them to the **Join XML Files** task, to make a single big XML file for easy consumption by the MIS system. This file is saved in a location that the MIS monitors.

#### 4. Cleanup

The individual XML reports are marked as `cp_tempfile` and, together with the other temporary files (the XML files produced by the **Run Script** task), they are deleted.

#### 5. Workflow End State

The **Router** directs each iteration of the input file to the right workflow end state based on the `State` workflow parameter set by the **Preflight Color for Digital Printing** task.

- For color strategies that gave a Delta E within tolerance (the `State` is `Pass`), the file goes to **OK**.
- For color strategies that didn't (the `State` still has an empty value), it goes to **Warning**.

The MIS system can then check the end state of the workflow and analyze the joined XML file containing the color accuracy information for the input file checked with all color strategies.



**Note:**

Like all Automation Engine workflows, this workflow can be triggered by a JDF file dropped into a "hot folder"/[folder access point](#) for example).

If the JDF contains information about the color strategies to check and the desired Delta E tolerance, they will overrule those set in the workflow parameters.

At the end of the workflow, the MIS system will get a JDF back, containing processing information and the location of the joined XML file.

### Pre-configured Preflight Color Workflow

For an easy start with the **Preflight Color for Digital Printing** task, you can use the pre-configured workflow made by Esko.

This workflow combines the ink set analysis from the **Preflight Color for Digital Printing** task with other Automation Engine capabilities, so that you can automatically:

- perform some PitStop preflight checks on your input file to determine whether your file's objects are compatible with EPM (CMY) printing (for example check for Rich Black objects, black-only images, etc.),
- analyze your file's spot colors to determine which ink set(s) you can print it with for a good color match (CMY, CMYK or CMYKOGV),
- process multiple input files and/or multipage files if needed,
- get both a PDF report with a clear indication of the ink sets you can use, and an XML report for your MIS or quoting/cost estimation system.

Esko will help you deploy this workflow. Please contact your Esko representative for more information.

You can also request a custom workflow based on this pre-configured workflow (for your click-based HP Indigo digital press), if this would fit your needs better.



**Note:** This workflow can process most jobs, but is not suitable for jobs containing white underprint, or jobs with more than 12 spot colors.

### Requirements

You need the following as a starting point for deploying the Preflight Color pre-configured workflow:

### Software Requirements

Compulsory:

- Automation Engine 18.0 or later with the "Reporting and 3D" and "Processor" modules
- either Color Pilot 16.x or later, or Color Engine Pilot 13.x (included with HP SmartStream Labels & Packaging Print Server 4.0 or later)

Optional:

- the "Automation Engine Connect" module, if you need to connect to an external system, for example an MIS system
- the EPM (Enhanced Productivity Mode) option on your HP SmartStream Labels & Packaging Print Server/HP Indigo digital Press, if you want to use CMY/EPM

### Hardware Requirements

Please see the requirements for your version of Automation Engine:

- for Automation Engine 18.0: [server](#) and [client](#) system requirements
- for Automation Engine 18.1: [server](#) and [client](#) system requirements
- for Automation Engine 20.0: [server](#) and [client](#) system requirements

### License Requirements

"Automation Engine Check Color Strategy"

### Preparation

You need to do some preparation to ensure that your Esko representative configures the workflow optimally for your needs.

#### Preparing Your Press Profiles

You need to:

- Make a list of all the HP Indigo digital presses and substrates you use.
- Make sure that for each press/substrate combination that you use, you have an accurate and up-to-date press profile.

Your press profiles should be made with your full press ink set (CMYKOGV).

Your Esko representative will create CMYKOGV, CMYK and CMY (if you are using it) color strategies based on your CMYKOGV profiles. These color strategies will be used in the workflow to check which ink set(s) your jobs can be printed with.



**Note:**

You can create digital press profiles in your Color (Engine) Pilot application.

Your color database contains a number of predefined profiles for certain substrates (for example HPI-CREAM-ANTIQU-CMYKOGV for the Fasson Cream Antique TOP substrate).

You can use these profiles for a faster start-up, but a profile made specifically for your press will always be more precise.

### Outlining Your Way of Working

Prepare the following information (that will be needed to configure your workflow):

- whether you work with [EPM/CMY](#),
- whether you need to connect to an [external system](#) (MIS, quoting/cost estimation system...),
- whether you want your [PDF reports](#) in a language other than English,
- which ink names you want to exclude from the ink set analysis (technical inks, varnish inks...),
- which Delta E formula and Delta E tolerance you use when assessing color matches.

If you are working with EPM, the workflow includes a set of additional checks to help assess EPM suitability:

- checking for black-only images or gradients,
- checking whether the job contains only black, or no black,
- checking for Rich Black objects (fill or stroke),
- checking for very small black objects or strokes,
- checking for very small black text,
- checking for areas with high Total Area Coverage.

You will have the opportunity to discuss which of these checks to apply to meet your particular needs with your Esko representative.

### Workflow Overview

There are two variants of the pre-configured Preflight Color workflow:

- the **main Preflight Color workflow**, that can:
  - perform some PitStop preflight checks on your input file to determine whether your file's objects are compatible with EPM (CMY) printing (for example check for Rich Black objects, black-only images, etc),
  - analyze your file's spot colors to determine which ink set(s) you can print it with for a good color match (CMY, CMYK or CMYKOGV),
  - get both a PDF report with a clear indication of the ink sets you can use, and an XML report for your MIS or quoting/cost estimation system.

See [Main Workflow](#) on page 1606.

- the **multipage Preflight Color workflow**, that can do all of the above, but for multiple input files and/or multipage files.

See [Multi-page Workflow](#) on page 1608.

### Main Workflow

The main pre-configured Preflight Color workflow variant can:

- perform some PitStop preflight checks on your input file to determine whether your file's objects are compatible with EPM (CMY) printing (for example check for Rich Black objects, Total Area Coverage, etc),
- analyze your file's spot colors to determine which ink set(s) you can print it with for a good color match (CMY, CMYK or CMYKOGV),
- get both a PDF report with a clear indication of the ink sets you can use, and an XML report for your MIS or quoting/cost estimation system.



**Note:** If you have multi-page files/multiple input files, you should use the [multi-page workflow variant](#) instead.

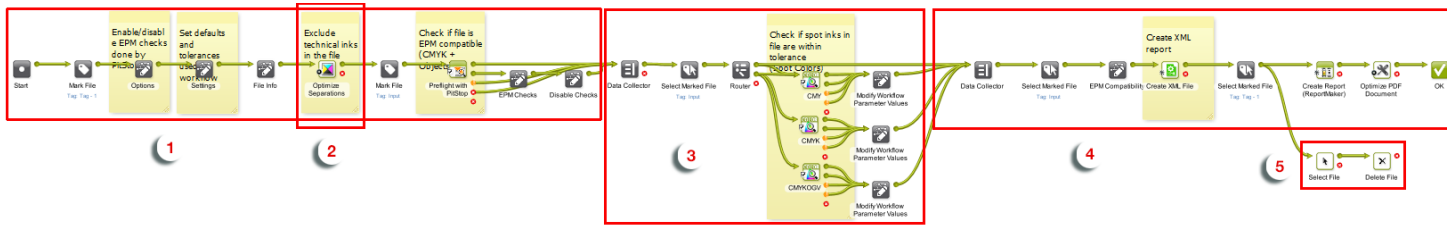

**1. EPM Preflight Check**

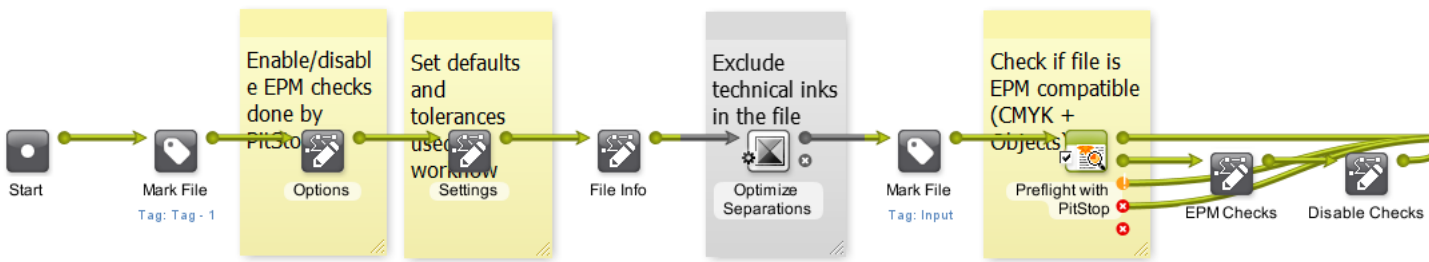

If you are *using EPM*, the workflow runs *EPM preflight checks* on your file. Those checks help assess how suitable EPM is for printing your job.

Your Esko representative will have tailored these checks to your way of working.

**2. Technical Inks Removal**

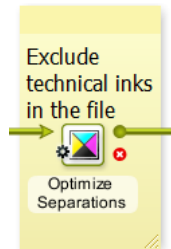

The workflow removes any technical/varnish... inks that don't need to be color converted.

**3. Color Analysis**

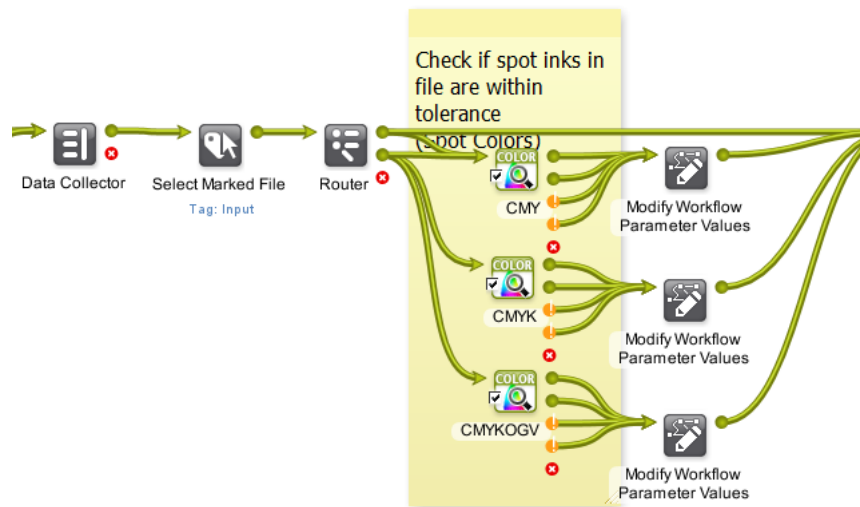

The workflow analyzes how accurately your job can be printed with CMY (if you are using EPM), CMYK and CMYKOGV using the substrate and press you chose.

To do this, it converts your job's colors using the *color strategies made for your press and substrate*.

**4. Reporting**

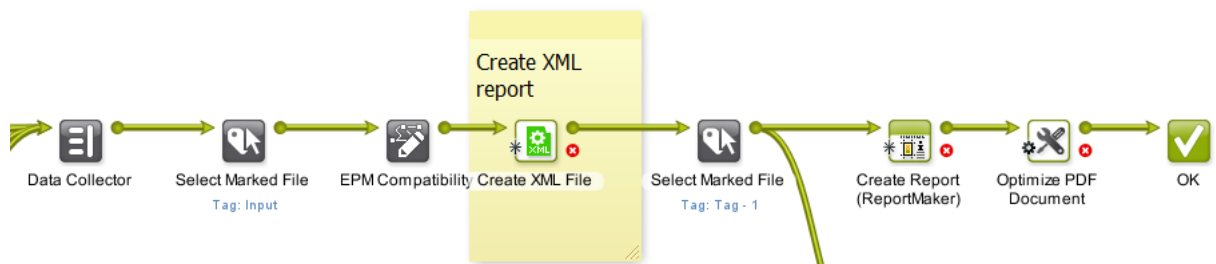

The workflow creates an *XML report* for your 3rd party system, and a *PDF report* for you.

The (final) XML report contains the results of the EPM preflight check, as well as the information from the individual XML reports generated by each **Preflight Color for Digital Printing** task (for CMY, CMYK and CMYKOGV).

**5. Cleanup**



The workflow cleans up the input files and individual XML reports.

**Multi-page Workflow**

The multi-page variant of the pre-configured Preflight Color workflow does everything the *main workflow* variant does, but can process:

- both single page and multi-page files,

- both single files and multiple input files.

You should use this workflow variant when working with multi-page files/multiple input files, but when working with single one-page files, we recommend you use the main workflow (as it is a little faster).

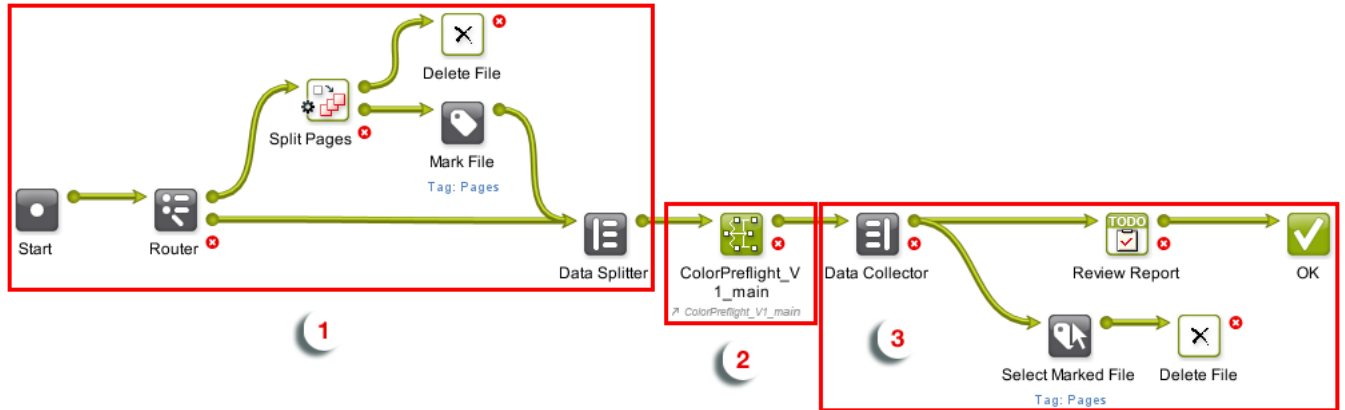

**1. File/Page Splitting**

The workflow checks the number of pages of the input file, and splits multi-page files into individual pages.

Then it feeds those pages (or any single page file that came in) individually to the rest of the workflow.

**2. Preflight and Color Analysis (Main Workflow)**

This subworkflow:

- runs EPM preflight checks on your file (if you are using EPM),
- removes any technical/varnish... inks that don't need to be color converted,
- analyzes how accurately your job can be printed with CMY (if you are using EPM), CMYK and CMYKOGV using the substrate and press you chose,
- creates an XML report for your 3rd party system, and a PDF report for you.

See [Main Workflow](#) on page 1606 for more details.

**3. Cleanup**

This part of the workflow collects all files, and:

- keeps the reports for you to review (it adds a review task to your To do list),
- deletes the input files and pages.

**Using the Workflow(s)**

Like with all Automation Engine workflows, you can run the pre-configured Preflight Color workflow on your files from the Pilot, Shuttle, or automatically through a connection with an upstream system.

If you are using the Pilot:

1. Select your one-up PDF and launch the pre-configured Preflight Color workflow.  
Use the workflow name given by your Esko representative (for example `ColorPreflight_v1_main`).

2. In the ticket that opens, choose the **Substrate** and **Press** you want to print your job with, and click **Launch**.
3. The workflow automatically:
  - a) splits the file's pages to analyze them one by one (if you are using a multipage file and the multipage workflow),
  - b) runs [EPM preflight checks](#) on your file (if you are using EPM),
  - c) removes any technical/varnish... inks that don't need to be color converted,
  - d) analyzes how accurately your job can be printed with CMY (if you are using EPM), CMYK and CMYKOGV using the substrate and press you chose,
  - e) creates an XML report for your 3rd party system, and a PDF report for you.
4. Based on the report data, you can easily see what ink set(s) give you a good color match, and decide on the best ink set to use based on cost and quality.

The report also contains more detailed information (about the Delta E values, EPM checks...) if you need it. See [PDF Report](#) on page 1610 and [XML Report](#) on page 1612.

### Workflow Reports

When using the pre-configured Preflight Color workflow, you get both:

- a PDF report with a clear indication of the ink sets you can use,
- an XML report for your MIS or quoting/cost estimation system.

#### **PDF Report**

The PDF report gives you a clear indication of the ink sets you can use, as well as more in-depth information to help you make a decision even in difficult cases.



## Color Preflight Report

**File Name** 01\_Red Wine Front.pdf

**Date** 29/01/2019

**Time** 16:41

**Substrate** PE-WHITE

**Press** HP Indigo WS6800

✘ CMY

✔ CMYK

✔ CMYKOGV

Check the Process Color Checks table on this page and the Spot Color Conversion table on page 2 for more info.

### Input Inks

Ink Name	Ink Book
<div style="width: 15px; height: 15px; background-color: red; margin-right: 5px;"></div> <span>201</span>	Pantone C
<div style="width: 15px; height: 15px; background-color: gray; margin-right: 5px;"></div> <span>Varnish</span>	<unregistered>

### Process Color Checks

Type of EPM Check	Value	EPM Compatibility
Check for black gradients		
Check for images in black		✔
Check if the input file only contains a black ink		✔
Check if the TAC is more than (%)	280 %	✔
Check if the input file is missing the black ink		✔
Check for black objects smaller than	0.35 mm	✔
Check for black strokes thinner than	0.35 mm	✔
Check for black text smaller than	6 pt	✔
Check for rich black object or stroke		✔

1. This area contains the job information: input file name, date and time, substrate and press chosen, and a thumbnail of the job.
2. You can see the ink set(s) that give you a good color match at a glance, with "traffic light" indicators.
3. This area lists the input file's inks. Only spot colors are converted (see [converted separations](#) for more information).
4. This shows the result of each [EPM check](#) ran by the workflow, and the values used where applicable.
5. On the report's second page, you can see the conversion details for each of your input inks, for the different ink sets. You can clearly see which conversion option(s) meet your color matching tolerance.

Spot Color Conversion		Delta E 2000 - Tolerance: 2.0							
Ink Name	Ink Set	dE	% C	% M	% Y	% K	% O	% G	% V
201	CMY	2.50	38.0	100.0	81.6	-	-	-	-
	CMYK	0.77	1.2	100.0	69.0	41.2	-	-	-
	CMYKOGV	0.05	0.0	96.1	0.0	42.7	69.4	0.0	0.0



**Note:** By default, this report is in English, but it can be generated in your language of choice (ask your Esko representative).

### XML Report

If you need to make the color conversion results available to an external system (for example an MIS or quoting software), use the XML report.

Like the PDF report, the XML report contains both high-level information about which ink set(s) give you a good color match for a particular job, and more in-depth data about EPM checks and color conversion.

- When using individual **Preflight Color for Digital Printing** tasks, you get an individual XML report per task, detailing whether your job's spot colors can be printed with the ink set chosen in the task (see [Color Preflight Results](#) on page 1598).
- When using the **pre-configured Preflight Color workflow**, you get a single XML report, that combines:
  - the results of the EPM checks the workflow ran on your job,
  - the information from the individual XML reports generated for each ink set.

```
<?xml version="1.0" encoding="UTF-8"?>
<ColorPreflight File="01_Red Wine Front.pdf" FileURL="file://eaw16d1273/ExampleJobContainer/AE_to_DFE_DH/Artwork" Date="20190129" Time="164122">
  <Settings>
    <Setting Set="DeltaE" Value="Delta E 2000"/>
    <Setting Set="Tolerance" Value="2"/>
    <Setting Set="TAC" Value="280"/>
    <Setting Set="Object" Value="0.35"/>
    <Setting Set="Strokes" Value="0.35"/>
    <Setting Set="Text" Value="6"/>
    <Setting Set="Substrate" Value="PE-WHITE"/>
    <Setting Set="Press" Value="HP Indigo WS6800"/>
  </Settings>
  <Inks>
    <Ink Seq="1" InkName="201" InkBook="PANTONE+ Solid Coated"/>
  </Inks>
  <EPMChecks EPMCompatibility="Not compatible">
    <Check CheckName="BlackGradients" Enabled="true" Value="false"/>
    <Check CheckName="BlackImages" Enabled="true" Value="false"/>
    <Check CheckName="BlackOnly" Enabled="true" Value="false"/>
    <Check CheckName="InkCov" Enabled="true" Value="false"/>
    <Check CheckName="NoBlack" Enabled="true" Value="true"/>
    <Check CheckName="SmallBlackObjects" Enabled="true" Value="false"/>
    <Check CheckName="SmallBlackStrokes" Enabled="true" Value="false"/>
    <Check CheckName="SmallBlackText" Enabled="true" Value="false"/>
    <Check CheckName="RichBlack" Enabled="true" Value="false"/>
  </EPMChecks>
  <CPCheck Enabled="true">
    <Check Seq="1" ColorStrategy="PE-WHITE_CMY" Inkset="CMY" Value="failed"/>
    <Check Seq="2" ColorStrategy="PE-WHITE_CMYK" Inkset="CMYK" Value="passed"/>
    <Check Seq="3" ColorStrategy="PE-WHITE_CMYKOGV" Inkset="CMYKOGV" Value="passed"/>
  </CPCheck>
  <Spots SpotColors="true">
    <Spot SpotName="201" >
      <Strategy Seq="1" DeltaE="2.50" Recipe="0.380 1.000 0.816 0.000 0.000 0.000" />
      <Strategy Seq="2" DeltaE="0.77" Recipe="0.012 1.000 0.690 0.412 0.000 0.000" />
      <Strategy Seq="3" DeltaE="0.05" Recipe="0.000 0.961 0.000 0.427 0.694 0.000 0.000" />
    </Spot>
  </Spots>
</ColorPreflight>
```

This combined XML report contains:

1. information about the job,
2. the settings used in the workflow (your color match tolerance, the values used in the EPM checks, the substrate and press chosen),
3. the spot colors to convert,
4. the results of the EPM checks,
5. a "passed" or "failed" result for each ink set,
6. the spot color conversion details.

### 19.3.3. Preflight Color for Digital Printing (Content based)

#### Concept

This task checks whether the color data in a file is within range to be printed satisfactory on a digital press.

Based on a selected color strategy and a maximum Delta E, it scans the input file's graphical data and concludes if the file survives the selected quality criteria.

This technology is also available on board ArtPro+, as a visual tool (part of the quality control tools). It is there called **'Digital Print Simulation'**.



**Important:** The related task [Preflight Color for Digital Print \(Ink based\)](#) has a different approach: it only checks the inks that are used in the input PDF file and then generates a table with information how they can be converted via selected strategy. It does not check how or where these inks are used in the input file. This (older) approach generates more numbers but they may be less relevant when printing this particular PDF input file.

### Task Settings

- **Color Strategy:** Select a digital printing color strategy that will be used to judge the color range when printing this file.
- **Delta E Limit:** When the file has any area with a Delta E higher than this value, the preflight will result in 'failed' (i.e. it will be reported as such in the output XML file). The maximum value in this field is 10.



**Note:** Processing Steps are not included in this calculation.



**Note:** This task only checks the content of the input file's first page.

### Result XML file

This task outputs an XML file that describes the preflight result (the maximum Delta E found in the file versus the allowed limit). It also mentions the average Delta E and the size of the area in the file (trim box) that was exceeding that allowed limit (in % and in mm<sup>2</sup>).

Some examples:

- This example shows that the preflight failed for this file because the maximum Delta E limit was much bigger than allowed by the ticket (Tolerance).

```
<?xml version="1.0" encoding="utf-8" ?>
<StrategyAccuracy Strategy="HPI-EPM-075_Digital" Status="failed">
  <PassFailSettings DeltaEMetric="Delta E 2000" Tolerance="3" />
  <Result MaximumDeltaE="11.68" AverageDeltaE="6.63" PercentageOver="87.80%"
    AreaOver="16198.86" />
</StrategyAccuracy>
```

- When a file passes this preflight, the XML will mention "passed":

```
<?xml version="1.0" encoding="utf-8" ?>
<StrategyAccuracy Strategy="HPI-EPM-050_Digital" Status="passed">
  <PassFailSettings DeltaEMetric="Delta E 2000" Tolerance="5" />
  <Result MaximumDeltaE="4.39" AverageDeltaE="2.90" PercentageOver="0.22%"
    AreaOver="69.17" />
</StrategyAccuracy>
```

## 19.3.4. Print on Digital Press



**Attention:** Unlike the "Submit to ..." tasks, this task currently still has more elaborated functionality but does not use the Devices view. The type of press and version of the DFE decide which type of task can be used.



**Important:** This task can serve 2 kinds of DFEs:

- The **HP SmartStream Labels and Packaging Print Server Powered by Esko**. In below pages, for sake of easy reading, we will name this the **HP DFE**.
- The **Esko (Inkjet) DFE**, a DFE serving several types of inkjet digital presses.



**Note:** To see which version of the DFE engine software supports which version of Automation Engine's **Print on Digital Press** task, check <http://www.esko.com/systemrequirements>.

### Working with a DFE (Digital Front End) Server

Automation Engine can use files in its Containers to create **Print Jobs** on a **DFE Server**. Automation Engine monitors those print jobs until they are printed on the digital press.

In Automation Engine:

- use the **Print on Digital Press** task to create print jobs on the DFE server. This step typically creates a step & repeat PDF and also executes color management.
- the **Print on Digital Press (Track)** task is started automatically and shows the status of the print jobs on that DFE server, also of print jobs that were not created via this task.

Both these tasks show detailed feedback for each step of the DFE printing process in the Pilot's **Tasks** pane.

### Setup

Before using those tasks, you must connect your Automation Engine server to your DFE server. This is done in the [Configure panel \(Digital Press\)](#). This task does not connect to devices that you set up in the Devices view.



**Note:** When your DFE server drives several digital presses, you also need to select the press to connect to.

### Supported File Types

The task can send these file types to a digital press:



**Note:** 'Static' print jobs are print jobs that are not VDP jobs.

For 'Static' print jobs:	For Variable Data Print jobs:
<ul style="list-style-type: none"> <li>• PDF</li> <li>• Normalized PDF (self-contained, so images embedded)</li> </ul> <div style="border: 1px solid #ccc; padding: 5px; margin-top: 10px;"> <p><b>Note:</b> This can be a one-up or an already stepped self-contained PDF.</p> </div>	<ul style="list-style-type: none"> <li>• PDF/VT (for example generated by Adobe Illustrator, by using the Dynamic VDP Plug-in).</li> <li>• VDT (Variable Data Template), also made in Adobe Illustrator, by using the Dynamic VDP plug-in.</li> </ul>

For 'Static' print jobs:	For Variable Data Print jobs:
<ul style="list-style-type: none"> <li>PDFPLA (Plato PDF)</li> </ul>	 <p><b>Note:</b> Before PDF/VT, the <b>Print on Digital Press (PPML)</b> task was used to have Automation Engine use PPML files to create variable print jobs on the DFE server. This task has been declared 'Soon Outdated'. Learn more in <a href="#">Print on Digital Press (PPML)(Soon Outdated)</a> on page 534.</p>



**Note:** If your MIS system stores print job parameters in JDF format, you can add that JDF file to the input of the **Print on Digital Press** task.

### About Variable Data Printing

When using a VDT file to print a VDP job, the expansion of the variable data (using the Variable Data Database) happens on the DFE. This is typically used when executing the expansion in Adobe Illustrator or Automation Engine takes too much processing resources.



**Note:**

- A VDT file contains **VDP objects** (placeholders for the variable data) and must be expanded to a PDF/VT file on the DFE server.
- A VDT file can be created with the Dynamic VDP DeskPack plug-in.
- Fonts used inside the VDT file must be installed on the DFE server.

### Using the Print on Digital Press Ticket in a Workflow

Unlike most workflow steps, the **Print on Digital Press** step does not create output files to be transferred to the next workflow step, but sends this output data to the DFE server.

This also means that this task step is always the final task in a workflow (branch).

In the workflow editor, you can see the number of files the task has successfully processed on its output pin called **Inputs**.



### Print on Digital Press Task Settings



Device: rddfe01 HP Indigo WS6800 Digital Press

Print Job Ticket: QC1641 📄 [ ]

General

Files

Step and Repeat

Transformation

Color Management

**Device:** Choose the digital press you want to send your file to. This list contains all the digital presses that you [added in Configure](#).

**Print Job Ticket:** Choose the print job ticket you have created on the DFE server to process and print jobs. In the list of tickets, notice the column indicating their **Workflow Type: Dynamic** or **Classic**.



**Note:** When using the **Print on Digital Press** task, make sure the DFE server is running and that the Print Controller on the DFE is running. When your task is stuck, check if the Digital Press connection is still OK ([in the Configure tool](#)).



**Note:** For all parameters in the below mentioned settings, you can choose the SmartName **[From Print Job Ticket]**. This will use the parameter value as defined in the selected DFE **Print Job Ticket**.

The value that the SmartName finds in the chosen **Print Job Ticket** is then shown to the right of the input field, between parenthesis. For

example: Copies:  (1)

If you added a JDF file to the task input, you can choose **[From JDF Ticket]** to use the parameter value defined in that JDF file.

We now illustrate the settings in the tab sheets:

**General Tab**

- **Print Job Name:** Keep the name if the input file or use a SmartName, Public Parameter or Workflow Parameter to define a different one.
- **Substrate:** Shows the list of substrates available on the press.
- **Copies:** Enter the number of copies to be printed.
- **Lead-in Sheets:** Enter the number of **Lead-in Sheets** that need to be printed at the start of the print run, or select <None> in case you don't want to use any.
- **Lead-out Sheets:** Enter the number of **Lead-out Sheets** that need to be printed at the end of the print run, or select <None> in case you don't want to use any.

- **Die Cut Layout Input Ink:** Specify the ink of the input file of which its contents will be used for the lead-in/lead-out sheet. This is typically a technical ink (for example `Cutter`).
- **Die Cut Layout Print Ink:** Specify the ink that will be used to print the lead-in/lead-out sheets. This must be one of the inks of the selected **Ink Set** in the [Color Management](#) tab.



**Note:** There is an exception to this rule for the HP DFE: if you print in CMY, you still use Black.

- **Comments:** Use SmartNames or choose **Custom** to enter print job related comments. They will be included with the file sent to the press, and become visible on the press's software panel (if your press model supports it).

### Files tab

In this tab, you define the **One-Ups**. The available options depend on whether this is a **Duplex print** or not.

For both part in this tab, you can choose **Custom** to define the settings here. Or you can choose **[From JDF Ticket]** to have them decided by an input JDF file.

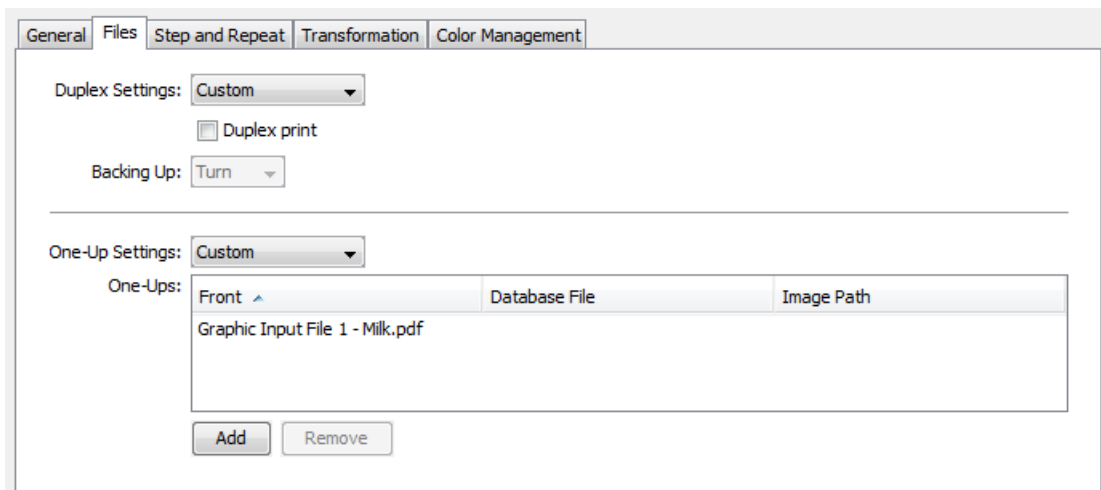

### About the Task Input Files and One-Ups

- For pre-imposed PDFs or single-grid step and repeat files, only one file is needed to be added here as **One-Up**. If you are using multi-grid step and repeat, add here as many file entries as you will send to this task.
- In the **Step and Repeat** tab, you can map the here defined one-ups as input files for the desired grid of the template step and repeat.
- In the case you use VDT Files, you also need to define a **Database file** and optionally an **Image path**.



**Note:** If the amount of the task's input files is not equal to the number of files specified in this Files tab, you will get an error.

Here are some specifics per use case:



### For a One Sided Print Job

For one sided print jobs, keep the **Duplex print** option disabled. In the **One Up settings**, choose **custom**.

### For a Duplex Print Job



**Note:** Not all digital presses support duplex printing.

To create a duplex print job, select the option **Duplex print**. Then define the

**Backing Up** mode:

- Select **Tumble** if you want the roll to be re-inserted into the digital press with rewinding.
- Select **Turn** if you want the roll to be re-inserted into the digital press without rewinding.

The **One-Up Settings** list allows you to **Custom** specify an input file for both the **Front** and the **Back** side of the print job.

With duplex print jobs, the same **Database File** and **Image Path** is used for the same grid for both **Front** and **Back**.

### For a VDP Job

For VDP jobs, you also need to specify the source of the variable information. To do this, follow these steps:

1. In **One-Up Settings**, choose **Custom**.
2. Click **Add**.
3. In the field for the database file, click **Select**.

In the **Select Database File** dialog, your **Source** can either be a

- **CSV File**. This is used in case the job contains complex information such as names, serial numbers or links to images.
- **Simple Database**. In this case, you only use "Simple Counters". This is suited for jobs that only require a simple sequence of numbers. Define how many records need to be generated in the field **Number of Records**.

Learn more in the user documentation of your DFE.



**Note:** Creating a VDP print job from a VDT file is supported for **Dynamic Workflows** (for version support, check <http://www.esko.com/systemrequirements>).

## Step & Repeat Tab

### Concept

The **Step & Repeat Settings** can be defined

- here, in this tab of this task. To do this, select **Custom** and read below how to define the settings. Disable the option **Step & Repeat** if you do not want to step & repeat.
- On the DFE, as part of the settings in the selected print job ticket. To do this, use the SmartName **[From Print Job Ticket]**. The task then reads that DFE ticket and shows its settings here, in read-only mode.
- by a JDF input file, using the SmartName **[From JDF Ticket]**.



**Note:** When using the PowerLayout DeskPack plug-in to send jobs to the DFE, you have already created your step & repeat, so that input file will here be considered as a one-up.

### Defining the Type of Step & Repeat in this Ticket

When you enabled the option **Step & Repeat** and you selected **custom** in **Step & Repeat Settings**, you can define **Template based** or **Tabular** layouts.

### Creating a Template based Step & Repeat

If you want to step & repeat from a template, select one in the **Template** field.



**Important:**

- If you are working with multiple input files, you need to use a step & repeat template. You cannot define a tabular step & repeat.
- Template based step & repeat is only supported when using a **Print Job Ticket** of the **Workflow Type 'Dynamic'**.



**Note:** Step & repeat templates and marks can be created in **DeskPack** (PowerLayout Standalone & Dynamic Marks). Learn more on how to create these templates in the [DeskPack documentation](#).

If your template has multiple grids and you have selected multiple one-ups in the **Files** tab, the task will automatically assign the first grid to the first one-up, etc. You can change this following these steps:

1. Select a grid either by clicking it in the **Sheet Preview** or by using the arrows in the **Grid** parameter.

2. In the list of **One-Ups** (that was specified in the files tab), select the one to go with this grid. In this way you can assign the desired number of input files to a certain grid.
3. Repeat this for each grid and one-up you want to associate.



**Note:** If the number of one-ups does not match the number of grids in the template, or if the size of a one-up does not match the size defined in the template's grid, you will see a warning icon in the sheet preview.

The **Grid Details** tab will automatically be filled with the data of the selected grid from the template.

When working with duplex print jobs, you need to specify an input file in the **One-Up** parameter (**Files** tab) for both front and back. See this example:

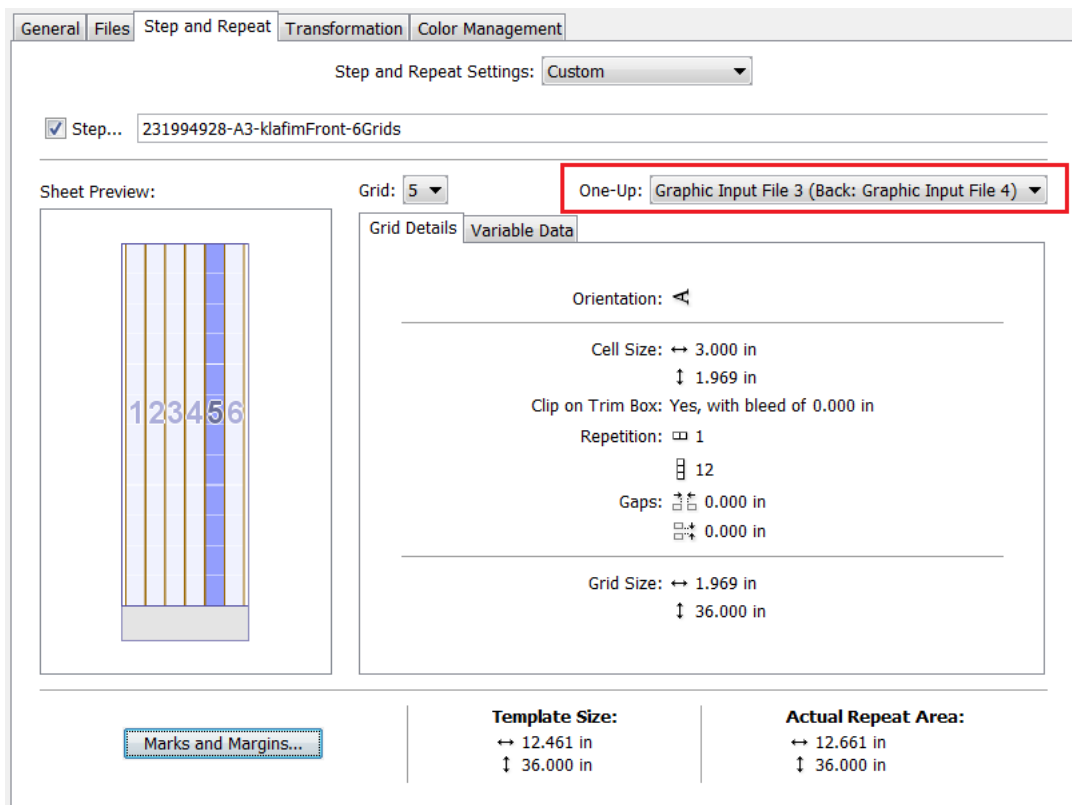
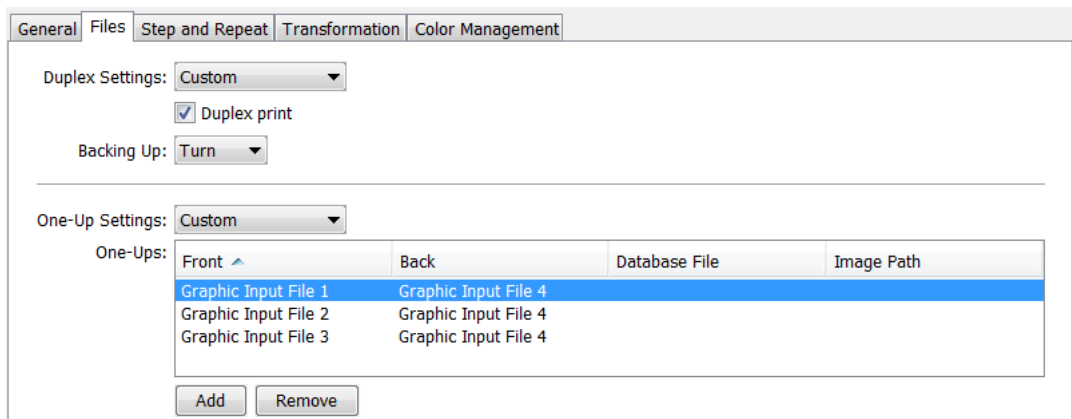

### Creating a Tabular Step & Repeat

This mode is available when you do not select a template. You can then specify all **Grid Details** in this ticket and you can optionally specify **Variable Data** settings.

Learn more below in [Grid Details](#) and in [Variable Data Tab](#) on page 1623.

### Sheet Preview

The **Sheet Preview** shows a preview of the result of your grid settings. You can also select grids by clicking on them in this preview.



**Note:** When you selected a template via a SmartName, the preview will not be available.

### Adding Finishing Marks and Defining Margins

Learn more below in [Marks and Margins](#) on page 1625.

### Indication of Grid/Template Size and Actual Repeat Area

At the bottom of the dialog, you will see the **Grid Size** (if you defined a tabular step & repeat), or the **Template Size** (if you used a template). This includes the margins you defined in [Marks and Margins](#).

The **Actual Repeat Area** shows the area actually used by the repetition, not including the margins. The width and length values are calculated based on the step & repeat parameters, including gaps. You cannot edit them.

### Grid Details Tab

When you have only defined one **One-up** file in the **Files** tab, this is where you can define tabular step and repeat settings for that single one-up.

Grid Details
Variable Data

Repeat one-up using its:

Trim Box  
 Media Box

Clip on trim box with bleed of

Orientation:

---

Available Repeat Area:

Substrate Width   
 Maximum Repeat Length

Repetition:

Maximum   
 Maximum   
 0.000 in   0.000 in



**Note:** If you are using a template, this tab will automatically be filled with data from the template (which is then non-editable).

**Repeat one-up using its:** Choose whether to use the dimensions of the one-up's **Trim Box** or **Media Box** to calculate the repetition grid.

You can see the **One-up Size** on the right.

**Clip on trim box with bleed of:** Use this option to add bleed when clipping a one-up on the **Trim Box**.



**Note:** This value should not be larger than half of the gap defined in the corresponding direction.



**Orientation:** Choose how to orientate the one-up.

**Available Repeat Area:** Define the width  and length  of the repeat area.

- The width can be set to **Substrate Width** (the width of the substrate you chose in the **Printing Properties**) or to a **Custom** value.
- The length can be set to the **Maximum Repeat Length** or to a **Custom** value.

**Repetition:** This defines the number of horizontal  and vertical  steps in the repetition grid. You can choose either:

- **Maximum:** The server will calculate the maximum amount of repetition steps possible within the **Available Repeat Area**.
- **Custom:** Enter the repetition amount of your choice.

**Gaps:** The values you enter here (for a horizontal  and a vertical  gap) will be used as a distance between the one-ups' borders in the repetition grid.



**Note:** For seamless printing, the top and bottom margin have to be equal to half of the vertical gap.

**Variable Data Tab**



**Note:** This tab can only be used when you are working on a variable print job (for this you need to have selected a Print Job Ticket of the **Workflow Type 'Dynamic'**).



**Note:** To send variable print jobs, the HP DFE needs to be version 4.0 or higher.

Use this tab to define how to distribute your variable data over the grid of one-ups that you built in the **Grid details** tab, or over the one-ups repeated according to the **Template** that you chose.

**Start:** Choose where to start printing your variable data (where to print the first record):

 top left,  top right,  bottom left,  bottom right.

The preview on the right shows a black dot representing the position of the first record.

For example, this distribution starts on the top left:



while this distribution below starts on the top right:



Choose also if the flow of variable data should run horizontally  or vertically .

The preview on the right reflects your choice.

Horizontal flow:



Vertical flow:





**Note:** The **Printing direction** marked with an arrow shows the direction that the paper flows through the press.



**Note:** When you selected a button via a SmartName, the preview will not be correct.

**Fill over:** Choose if you want to distribute the variable data over the **Complete Job** or over **Blocks**.

If you choose **Blocks**, the variable data flow will run over **Blocks** of a certain size, then run over the next **Block** when the previous one is complete.

You can see an example of **Blocks** in the preview.



**Block Size:** You can define the size in **Grid Rows, Sheets, Feet** or **Meters**.

If you have chosen to **Fill over** the **Complete Job**, then the **Block Size** will be **1.00 Job** by default.

You can set it to another unit if you still want to print in **Blocks**, but without having the variable data flow respect the **Block**. This is useful if you want to add gaps (see below).



**Add gap between blocks:** This adds white space in between the **Blocks**. It is available when you have chosen to **Fill over Blocks**, or to fill over the **Complete Job** but still have **Blocks** (as explained above).

**Gap size:** This is available when you have selected **Add gap between blocks**. Define the gap size in **Grid Rows, Sheets, Feet** or **Meters**.

**Marks and Margins**

Click on **Marks and Margins** to add marks and margins to your output.



**Note:** You can also set marks and margins when you are not using step and repeat in your print job (when the **Step and Repeat** option at the top of the dialog is deselected).

### Marks

Choose if you want to add **Finishing Marks** to your print job. Finishing marks are used to align the substrate for cutting. Select a set from the list or use **[From Print Job]** or any other SmartName.

The list offers the marks that you made in 'Dynamic Marks' and, in case of an HP DFE, also the default marks **1 x LabelRow**, **1 x Sheet** or **2 x LabelRow**.



**Note:** These marks are all visible when **Step & Repeat** is active, or from within PowerLayout. When **Step & Repeat** is inactive, only **1 x Sheet** is shown.



**Note:** If you are using a Step and Repeat template from the DFE, you can not add finishing marks here. The marks from the template will be applied.



**Note:** Second pass marks (also called "reinsertion marks") can not be controlled from Automation Engine. Those can only be set on board the DFE ticket

### Margins

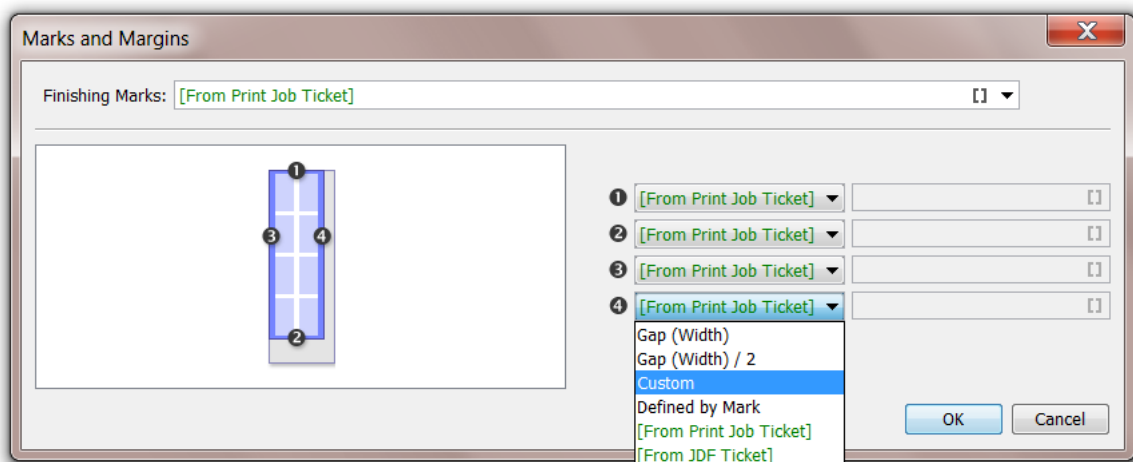

You can define each margin (**1**, **2**, **3** and **4**) using the following:

- **Gap (Length or Width):** The size of a gap between one-ups.
- **Gap (Length or Width) / 2:** Half the size of a gap between one-ups. This is typically used for top and bottom margins, as the bottom margin of one sheet plus the top margin of the next sheet will be equal to one gap.
- **Custom:** a custom number (formulas are not allowed).



**Note:** If you selected a finishing mark which size you defined in the DFE's configuration tool, the corresponding margin will show up as *Defined by Mark*.

This means that the margin is automatically large enough to provide space for this finishing mark. For example, if you, on a HP DFE, selected the default mark **1 x LabelRow**, which is set in the DFE configuration tool to need 8 mm of right margin, the right margin (**4**) will be set to *Defined by Mark* and be 8 mm wide.



### Transformation Tab

- **Vertical Scale:** Use this to scale the print job vertically (in the length).
- **Horizontal Scale:** Use this to scale the print job horizontally (in the width).
- **Rotation:** Choose the rotation of the print job (**None**, **90° CW**, **180°** or **90° CCW**).



**Note:** **Rotation** is disabled when **Step and Repeat** is enabled.

- **Mirror:** Choose whether or not to mirror the contents of the print job.

### Color Management Tab

- **Ink Set:** Choose the set of process inks that will be generated by the RIP. The list depends on the press model.
- **Use:** Define if you want to use color management when RIP'ing the print job (to convert the file separations to the ink set used by the press), and what kind of color management. Choose **<None>** if you don't want to use any color management settings for this conversion.
- When you do want use color management here, select a **Color Strategy** from the list (or use a SmartName).

## 19.3.5. Submit to Esko DFE



**Note:** This task is only used as part of a pre-defined workflow used in the [workspace 'Roll-fed Labels'](#).

### Concept

This task submits a print-ready PDF or a JDF referencing print-ready PDF files to an Esko DFE.

An Esko DFE here means any DFE developed by Esko, so also those that were re-branded by 3rd party vendors and named "Powered by Esko".



**Restriction:** The HP flavor of the Esko DFE requires that the file has the minimum repeat length for a typical HP press (HP6x00), which is 470 mm. When you submit a PDF file that is smaller than 470 mm to this type of DFE, this Submit task will still process the file but, on the DFE, the HP print job is not created.

### Task Options

- **Device:** Select a device from the list of Esko DFE devices that you added in the Device view.
- **Due Date:** Choose a time when this job should be printed.



**Note:** A due date specified by a SmartName must resolve to a valid ISO 8601 string, i.e. the format `yyyy-mm-ddThh:mm:ss`. For example `2017-03-10T10:00:00`.

- **Copies:** Specify the number of frames to print.
- **Print Job Ticket:** Click on to select one from the list of tickets on the DFE of the selected device.
- **Substrate:** Click on to select a substrate from the list of substrates specified on that DFE.
- **Color Strategy:** Click on to select a color strategy from the list of strategies specified on that DFE.

When the specified Print Job Ticket is of the type "**Classic**", only "Classic" Color Strategies are allowed. When the specified Print Job Ticket is of type "**Dynamic**", all Color Strategies are allowed.



**Note:** The priority of the print job in the Esko DFE is inherited from the priority of this task.

### 19.3.6. Submit to HP SmartStream Production Pro Print Server

#### Concept

HP's Digital Front End "Production Pro" is used to drive HP Indigo presses. This task submits a JDF file to the HP Production Pro. The JDF includes references to the print-ready PDF file(s) and various options on how this job should be printed..

Typically, Automation Engine creates a step & repeat PDF including marks and submits that file to the DFE in its original color space (process + spot colors).

#### Task Options

- Tab **General**

- **Device:** Select a device from the list of configured HP Production Pro devices that you added in the Device view.
- **Due Date:** Choose a time when this job should be printed.



**Note:** A due date specified by a SmartName must resolve to a valid ISO 8601 string, i.e. the format `yyyy-mm-ddTThh:mm:ss`. For example `2017-03-10T10:00:00`.

- **Internet Input Method:** Click on  to select the '**Internet Input method**' from the list of available methods that were specified on the HP Production Pro. (On the HP Production Pro, this term is used for a 'ticket').
- **Print Job Name:** In stead of the default name based on the input file, you can here specify a different name for how this print job will appear on the HP Production Pro.
- **Comments:** You can here for example add instructions for the press operator. They will appear on the Production Pro (**Job > Information > Comments**) and also on the HP press interface.
- **Automatic Export:** Select whether, on the HP Production Pro, the submitted job should (afterwards) automatically be exported (a form of archiving).
  - **Use value from internet input method:** as defined above (default value)
  - **Yes** (SmartName resolving to 'true')
  - **No** (SmartName resolving to 'false').



**Note:** This requires the HP Production Pro to be on v8.2 or higher.

- Tab **Production**



- **Copies:** Specify how many copies of the input file should be printed.



**Note:** When this task is started from the browser client workspace 'Roll-fed Labels', then this is typically a Step & Repeat PDF, there referred to as a 'frame' or 'sheet'.



**Attention:** When all the frames in the job are identical (so a static job, also without LILO sheets), then this number of copies will reflect the number of frames to be printed. This way the HP press operator can still easily overrule the run length.

- **Substrate:** Click on  to select a substrate from the list of substrates specified on that HP Production Pro. Alternatively, leave this field to the default '**Use value from internet input method**' or use a SmartName.
- **Color Strategy:** Click on  to select a color strategy from the list of strategies specified on that HP Production Pro. Alternatively, leave this field to the default '**Use value from internet input method**' or use a SmartName.
- **Lead-in Sheets:** Enter the number of **Lead-in Sheets** that need to be printed at the start of the print run, or select <None> in case you don't want to use any.
- **Lead-out Sheets:** Enter the number of **Lead-out Sheets** that need to be printed at the end of the print run, or select <None> in case you don't want to use any.
- **Die Cut Layout Input Ink:** Specify the ink of the input file of which its contents will be used for the lead-in/lead-out sheet. This is typically a technical ink (for example `Cutter`).
- **Die Cut Layout Output Ink:** Specify the ink that will be used to print the lead-in/lead-out sheets. This must be one of the inks of the selected PDF file.



**Note:** There is an exception to this rule for the HP DFE: If you print in CMY, you still use Black.

- Tab **Transformation**
  - **Rotation:** Choose the rotation of the print job from the list.
  - **Mirror:** Choose whether or not to mirror the contents of the print job.

### 19.3.7. Submit to Generic DFE (PRE-RELEASE)

This type of task is used to integrate with a generic DFE, for example the one of a Bobst digital press.

It uses the same JDF/JMF interface as the task 'Submit to Esko DFE'.

For all info on the (identical) ticket options, we refer to the page on [Submit to Esko DFE](#).

## 19.4. Using Shared Resources between AE and the DFE

By default, Automation Engine and the Digital Front End are each installed with their own resources (for color management, dot gain curves, step & repeat templates and marks).

However, when working with Automation Engine and the Digital Front End together, you need to make sure they are using the same resources.

This is very important, as if you set some parameters in Automation Engine using resources that are not available to the DFE, you will have trouble sending your job to print at the DFE side.



**Note:**

You should only use one Color Pilot application for color management, that works with the same color database that both Automation Engine and the Digital Front End use.

This should be the Color Pilot application that came with your Digital Front End software.

**Before You Start**

Before you start merging and redirecting resources, make sure that:

- Automation Engine, your Digital Front End server and Color Pilot are located in the same Local Area Network,
- your DFE server's BGSYSTEM user has read and write access to the following shares on your Automation Engine server:

```
bg_data_cms_v010
bg_data_dgc_v010
bg_data_custom_v010
bg_data_marks_v010
```

**Cases**

- If this is your first installation of both applications, you can just redirect your Digital Front End to look at Automation Engine's resources.

See [Using Shared Resources for Newly Installed Applications](#) on page 1630.

- If you have been working with Automation Engine and your Digital Front End for a while, you probably have custom data in both sets of resources.

In this case you also need to merge your resources. See [Using Shared Resources for Existing Applications](#) on page 1631.

**19.4.1. Using Shared Resources for Newly Installed Applications**

If you have just installed both Automation Engine and your Digital Front End software for the first time, their resources only contain default data.

In this case, you just need to make sure that your Digital Front End and Color Pilot software use Automation Engine's resources.

1. Redirect your DFE server to use Automation Engine's resources instead of its own.
  - a) Open your DFE server's Configuration Tool by going to **Start > All Programs > Esko > [DFE Server Type and Version] > [DFE Server Type] DFE Configuration**.
  - b) At the bottom of the **Data** tab, under **Resources Search Path**, click the **Configure...** link.
  - c) In the **Resource Server location changed** pop-up, select **On another computer**, and enter the name of your Automation Engine server.
  - d) Click **OK**, and **OK** again in the Configuration Tool.

This makes sure the DFE uses Automation Engine's color database, curves database, Step & Repeat templates database and marks database.

2. Check that your Color Pilot application uses the color database set in your DFE server (which is the Automation Engine color database).
  - a) Go to **Edit > Preferences...** and click the **Servers** tab.
  - b) Under **Esko Server**, check or fill in the connection details for your DFE server (**Server Name**, **User Name** and **Password**).
  - c) Click the **Check Connection** button. You should see **Status: Connected** (with a green dot).
  - d) Click the **Database** tab and select **Obtain from Esko server**. The name of your DFE server should be visible.
  - e) Click **OK**.
  - f) If you get prompted to restart your Color Pilot, click **Restart Now** to confirm.

### 19.4.2. Using Shared Resources for Existing Applications

If you have been working with Automation Engine and your Digital Front End for a while, you probably have custom data in both sets of resources.

In this case you also need to:

- copy the curves, Step & Repeat and marks data from your DFE server to Automation Engine,
- merge your color databases, by exporting the data from your DFE's color database into your Automation Engine's color database.



**Note:** To minimize disruptions, you should do this when your DFE server and your Automation Engine server are not in use.

1. Copy your DFE's curves data to Automation Engine.

The curves data is typically located in `C:\Esko\bg_data_dgc_v010` on your DFE server.

Merge it into your Automation Engine server's `bg_data_dgc_v010` share (\\[AE Server Name]\bg\_data\_dgc\_v010).

2. Copy your DFE's Step & Repeat data to Automation Engine.

Step & Repeat templates are typically located in `C:\Esko\bg_data_custom_v010` on your DFE server.

Merge this folder into \\[AE Server Name]\bg\_data\_custom\_v010.

3. Copy your DFE's marks data to Automation Engine.

The marks data is typically located in `C:\Esko\bg_data_marks_v010` on your DFE server.

Merge this folder into \\[AE Server Name]\bg\_data\_marks\_v010.



**Note:** Some marks data is also present in the `bg_data_custom_v010` folder, that was merged in the previous step.

4. Open your Color Pilot application to merge the color databases.
5. Check that your Color Pilot uses the color database of your DFE server.
  - a) Go to **Edit > Preferences...** and click the **Servers** tab.

- b) Under **Esko Server**, check or fill in the connection details for your DFE server (**Server Name**, **User Name** and **Password**).
  - c) Click the **Check Connection** button. You should see **Status: Connected** (with a green dot).
  - d) Click the **Database** tab and select **Obtain from Esko server**. The name of your DFE server should be visible.
  - e) Click **OK**.
  - f) If you get prompted to restart your Color Pilot, click **Restart Now** to confirm.
6. Still in Color Pilot, export the data from your DFE server's color database.
- a) Go to **File > Export Library...**
  - b) In the **Export Library** dialog, check that **Export as one single archive** is selected.
  - c) Browse to your desired location, change the name of the FilePacker (.fp) archive that will be exported if you want, and click **Export**.
  - d) Depending on the amount of data, you may get a warning that the export can take a long time. Click **Yes**.
7. Redirect your DFE server to use Automation Engine's color database instead of its own.
- a) Open your DFE server's Configuration Tool by going to **Start > All Programs > Esko > [DFE Server Type and Version] > [DFE Server Type] DFE Configuration**.
  - b) At the bottom of the **Data** tab, under **Resources Search Path**, click the **Configure...** link.
  - c) In the **Resource Server location changed** pop-up, select **On another computer**, and enter the name of your Automation Engine server.
  - d) Click **OK**, and **OK** again in the Configuration Tool.
8. Restart Color Pilot.  
 Since Color Pilot takes the location of the color database from the DFE server, and the DFE server takes it from the Automation Engine server, Color Pilot is now using Automation Engine's color database.
9. In Color Pilot, import the DFE color database archive into the Automation Engine color database.
- a) Go to **File > Import...**
  - b) Browse to the FilePacker archive of the DFE color database that you exported earlier and click **Open**.
  - c) In the **Import** dialog, click **Import All**.



**Note:**

If some items with custom data are present in both color databases (like for example the **designer** ink book), they will be merged.

Merging adds any data from the archive that wasn't present in the Automation Engine database, but does not replace any data.

- d) Click **Close** when the import is done.

# 20. AE SaaS: When your AE is in a Data Center

---

## 20.1. SaaS Concept and Setups

---

### SaaS versus On-Premises

- **Automation Engine On-Premises**

The Automation Engine server software is on-premises when it is installed on a computer of your organization, at a location that you chose. This Automation Engine can be used within the LAN it is installed in.

The company that purchased (or rents) the licenses of this Automation Engine typically also fully manages this setup. Their staff is trained by Esko in its configuration and usage.

This company, depending on its maintenance contract, can be assisted by Esko support staff (Esko direct or via a reseller).

- **Automation Engine SaaS**

Software as a Service is a software delivery model in which software is centrally hosted at a hosting company that is not a location of the end-user organization, often referred to a 'data center'. Esko decides the hosting company and manages the installation and maintenance of the software.

An Automation Engine SaaS setup is a single-tenant setup. It is dedicated to one Esko customer.

Your organization, based on an annual license subscription, configures and uses the attributed server(s). All access to it from applications within your organization (Pilot, browser client, ArtPro + ,DeskPack, devices) happens via the web in a secure way.

The files and central resources that an Automation Engine SaaS can process also need to be present at the hosting company, in that data center. Data that are no longer active can be off-loaded to reside on Esko Cloud.

### Setting up Automation Engine SaaS: Who does what?

- Initially, Esko's Platform Operations team ('PlatOps') will have been closely involved with the customer and Esko sales to agree on the setup in the data center.
- Esko PlatOps takes care of the installation and main configuration of this agreed setup at the data center company.
- Esko Academy, especially when Automation Engine was not yet used before this SaaS setup, provides training of the (licensed) Esko software tools used in this setup.
- In a SaaS setup, the role of administrator is split in 2 levels:
  - **System Admin**  
Esko PlatOps + Esko Support team members.  
The configuration tools they use are not available for non-Esko users.
  - **Operational Manager**

The customer's administrator(s) of Automation Engine, responsible for daily configuration and customization. The operational manager may also provide application training of other (admin) users.

In the Configure tool of an AE SaaS setup, this operational manager will see a reduced list of topics to manage. The full list is only available to Esko PlatOps team members.

- **User**

The daily user of Automation Engine (client) tools.

The operational manager may have reduced it access rights.

### 20.1.1. Not available in SaaS (only in On-Premises)

Following features are not supported (not available) in an AE SaaS setup. The main reason is that they are technically impossible in a SaaS setup or that their use case is missing:

- RIP'ing (from AE SaaS data) on a local Imaging Engine.
  - RIP'ing with Imaging Engine needs to happen on the IE that is on board the AE SaaS server setup.
- Regular hot folders (Folder Access Point)
  - but replaceable with the setup of 'Agent Folders'
- Task tickets larger than 1,9 Mb can not be saved. Learn more in [Ticket Size](#) on page 136.
- Interacting with local (external) databases via SmartNames or via a Database Access Point
  - The 'Interact with Database' task is supported
- SAP connectivity: no SAP Access Point and no 'Interact with SAP' task.
- Shuttle integration with editors
  - replaced in ArtPro+ and DeskPack by its integration with My Workspace (browser client)
- Esko classic editors (ArtPro, PackEdge, Plato, I-cut, FastImpose). Learn more in [The Syncer Tool](#) on page 1670.
  - As a consequence, resources that are only editable by these classic editors, i.e. SmartMarks and CAD style data, are also not supported in an AE SaaS setup.
- Connecting desktop client applications (Automation Engine Pilot, Automation Engine Agent, Color Pilot, ArtPro+, DeskPack, ...) to AE SaaS over a proxy server.
- The Server Admin web page is not available. It is only available to Esko Platform Operations staff who have access to the data center.
- No support for LDAP user accounts.
- Standard Edition ArtiosCAD Servers
- PantoneLIVE
- External Script Runners are supported with this limitation that [input files need to be downloaded to the script runner](#) and need to be processed there.
- When outputting to a CDI device, the [semi-automatic workflow with the DFS Merger](#) is not supported in a SaaS setup.
- (PS-)Printing to a local (office) printer: not possible via PS-print command/task from AE SaaS
  - but is possible via an Agent Folder - at least if the printer can pick up the file somehow (like a GMG proofer can)



- FlexRip
- Commercial Print (page) workflow modes in Pilot

### 20.1.2. FAQs

We refer to the section FAQs in the eLearning module "AE SaaS - Concept and Technology Overview"



**Note:** All eLearning modules can be found on [the Esko Blended Learning platform](#).

## 20.2. SaaS Technology Components

See the AE SaaS eLearning module 'Concept & Technology'



**Note:** All eLearning modules can be found on [the Esko Blended Learning platform](#).

The eLearning module "AE SaaS - Concept and technology Overview" includes a step by step explanation of this schema:

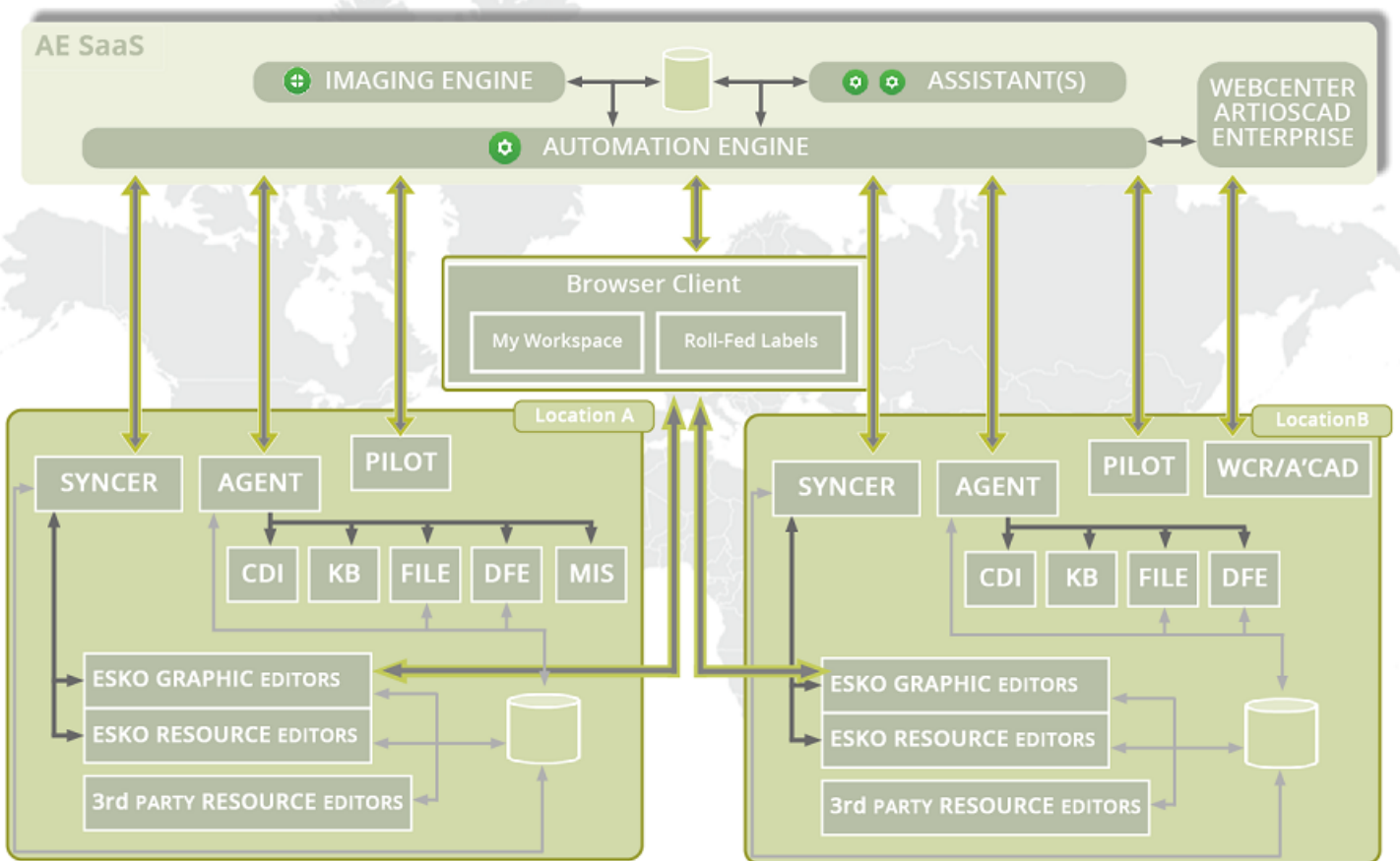

### Main Technical Components

- **Agent:** An Automation Engine Agent is a component in a local network that represents the AE SaaS server. It communicates to local devices and provides the necessary files and resources.



**Attention:** The local administrator needs to install this component on a chosen (Windows) computer and also take care of its updates.

Learn more in [The Agent](#) on page 1637.

- **Syncer:** When editing ArtPro+ or DeskPack files, this tool handles the data synchronisation between your local cache (of your local workstation) and the source data in the AE Container. Learn more in [The Syncer Tool](#) on page 1670.
- **App Launcher:** When you ask to open a file in the AE browser client in some local application, this tool enables this and also helps to define which application you want to open for which file type. Learn more in [The App Launcher Tool](#).

## 20.2.1. How the Pilot client Adapts to a SaaS Connection

A Pilot client adapts to the type of server setup in these areas:

- **Connection protocol:** Depending on the chosen server, the Pilot adapts its connection protocol:
  - When the selected Automation Engine server is on-premises: the connection is done over TCP/IP and a classic version of the Pilot will open.
  - When the selected Automation Engine is a SaaS server in a data center, the connection is done over HTTPS (the 'Tunnel' protocol) and some functionality in the Pilot will not appear.
- **Configure tool**
  - **Full:** A Pilot using a TCP/IP connection will open a Configure tool with all topics available. This enables a full system configuration of an on-premises server, by its administrator or by Esko support staff
  - **Limited:** A Pilot using an HTTPS connection will open a Configure tool with a limited list of topics. The customer's Automation Engine administrator so only has access to topics on operational level.

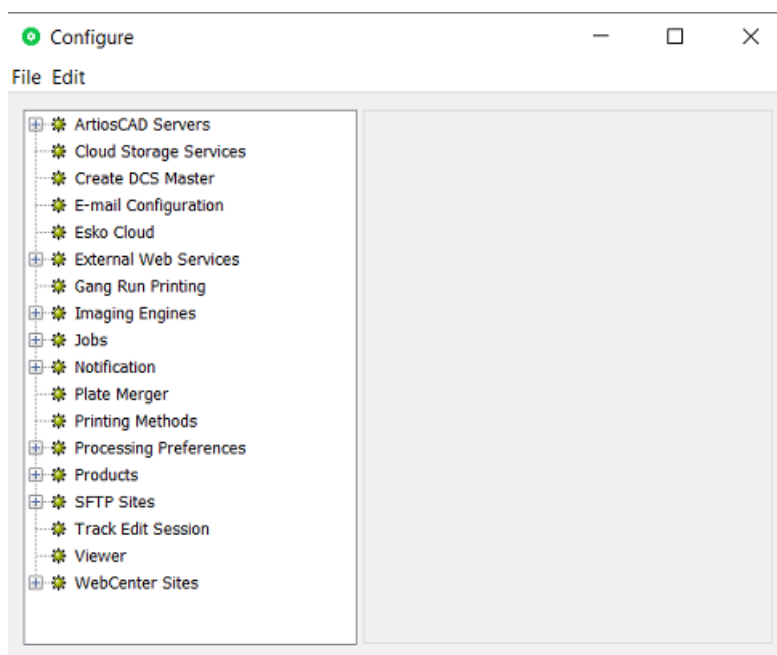

**Note:** When Esko PlatOps staff is 'present' within the network of the hosting company and signed in to an AE SaaS server within that network, the connection will be TCP/IP and so they will have access to the full set of topics in the Configure tool.

## 20.2.2. The Agent

The Agent was introduced in [SaaS Technology Components](#) on page 1635.

The Agent is a component that enables general communication between the local site and the AE SaaS server. It specifically enables these tools:

- Setting up a local **Device**, to output from the AE SaaS server to your local CDI, DFE or Kongsberg cutting table.
- HTTP JDF/JMF communication to a local device that you can't add to the Devices view, for example an AVT inspection system, a Xeikon digital press, etc. This avoids the need to expose the HTTP port of that local device, something that your local IT will refuse for security reasons.
- Interact with a local external database. An Agent will do this on request of the AE SaaS task '[Interact with Database.](#)'
- Interact with a local web service: An AE SaaS server in a data center will not be able to access an external system that is not exposed to the internet, as will be the case for for example the MIS in your company's LAN. To still enable this (in 2 directions), an AE SaaS will use the local Agent.

These tools will then communicate via that Agent: The task [Interact with Web Service](#) and the [Web Service Access Point](#).

- Some classic communication via file exchange that is also wanted between a location and the SaaS server:
  - Extra Access Point: [Agent Folder Access Point](#) on page 1642
  - Extra task: [Task 'Send File to Automation Engine Agent'](#) on page 1646.

The local administrator needs to [install this Agent](#) on a local (Windows) computer and also take care of its updates.

The [Agents overview page](#) allows an administrator to check their status and version without having to connect to the AE server itself.

### Agent Installation

Installing an Agent is also done from browser client's home page. Follow these steps:

On the computer in the location where you want to install an Agent:

- Make sure the computer meets its requirements to serve as an Agent. See a special page under [the system requirements page of Automation Engine](#).
- In a browser, go to `http://<AESaaSserverName>:9000/`
- Click on the AE icon and in the left slide-out click on **'Home'**.
- Go to **Apps & Tools > > Tools**.
- For the tool **Automation Engine Agent**, click **Download**.

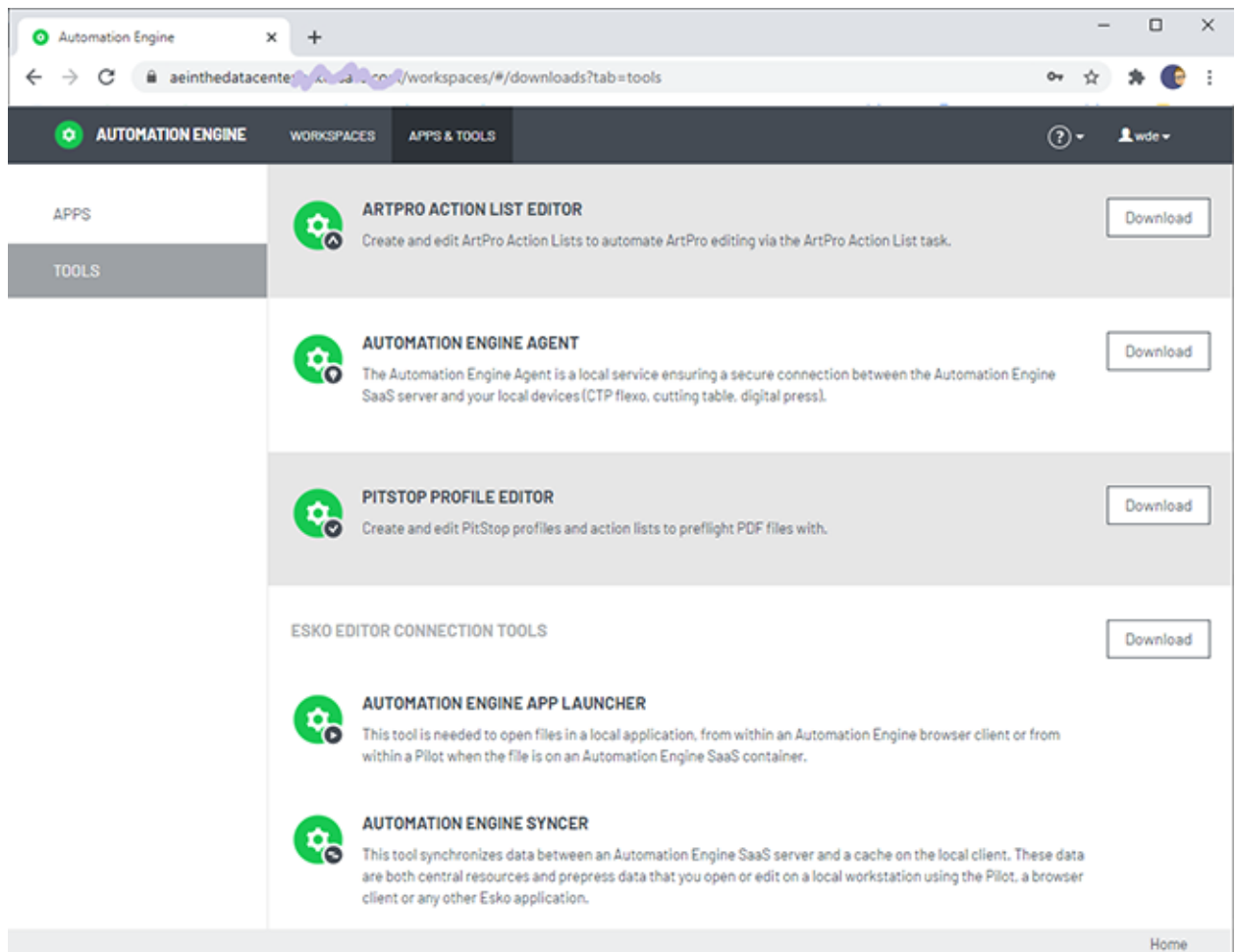

- Follow the installation instructions.
- When finished, you will have this extra desktop shortcut:

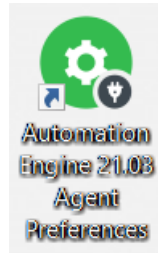

- Double click it open the [Agent Preferences web pages](#).

### Agent Preferences web pages



**Important:** Find a valuable instruction video about this configuration in the course "AE SaaS - Agent Configuration for Administrators" on [Esko Blended Learning platform](#).

To open the web pages to configure and set preferences for your local Agent, go the computer where you installed the Agent and

- open the URL `http://localhost:44122`.
- or double click the desktop icon for these pages.



**Attention:** To make any changes, you need an administrator account to the AE SaaS server.



**Note:** To support live updates, your browser needs to minimally this version: Chrome v61, Safari v30, Firefox v55, Edge v14).

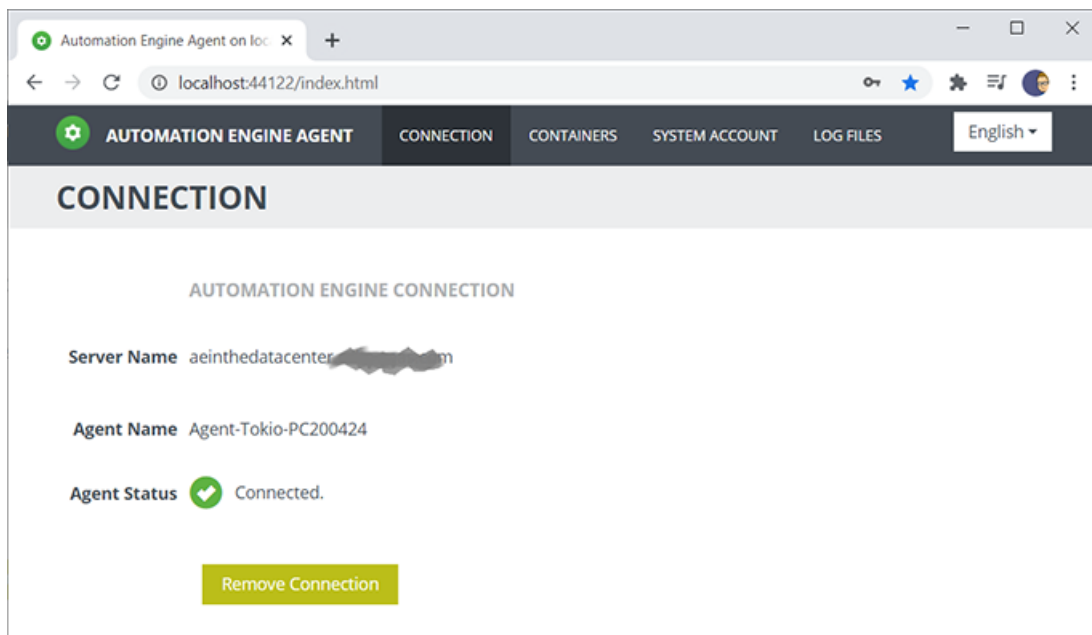

**Note:** For most of below actions, you will be asked to authenticate (again) as an Automation Engine administrator user.

## Connection

When signing in here for the first time, the Agent Status will mention that the Agent is running but that it is not connected to an Automation Engine server.

- **Server Name:** Enter the name of your AE SaaS server.
- **Agent Name:** Enter a name for this local Agent. This name will be picked up in task tickets or other tools that users might see.

You only need one Agent per location, so we advise to refer to this location in its name. You can also add the actual name of the computer, but be aware that many users might not know that name. A good example: `AE-Agent-Tokio-PC375877`.



**Note:** The URL encoded version of this name should be smaller than 36 characters.

In the [Users](#) view, a user named after this Agent will appear. It has no functionality there. This user is linked to the user-based token that an Agent uses in its communication.

- **Agent Status** and subsequent action button:
  - "Running, not connected to an Automation Engine server" - button **Connect:** Status when there is no configuration yet. Click **Connect** to connect and test the link between your local Agent and the SaaS server.

The authentication also supports SSO (Okta and AzureAD) to sign in to the Agent (instead of having to create an internal user with admin privileges). Learn more about the configuration of OpenID in [Identity Providers](#) on page 1998.

- "Connected" - button **Remove Connection:** Click **Remove Connection** to remove the connection.



**Note:** This does not remove the Agent service or any of its configuration, only its connection to AE.

- "Automation Engine is up and running. The agent could not connect to Automation Engine" - button **Connect Again:** The connection is invalid. Click **Connect Again** to try again.
- "Could not connect to Automation Engine. Please verify whether Automation Engine is up and running." - button **Modify Connection:** The above specified AE SaaS server can't be reached.
  - Check if the server is indeed running. As soon as the server is back up and running again, the connection will automatically be re-established.
  - Click **Modify Connection** to change a field before trying again. Any Admin user can set or remove this connection.



**Important:** Early users of an Agent v22.07 that upgraded to v22.11 are recommended to remove and re-establish this connection before upgrading to a next major version (v23.03). This is required to start using the user-based tokens of the dedicated Agent-user described above.

## Containers

You can set up local **Agent Containers**. These are data zones within your local network that you want to use in some connection to the AE Server.

There are 3 main use cases for such Agent Containers:

- **To send files** to the AE SaaS server ; to serve as local "hot folder". For example
  - to trigger an action.
  - to send JDF files from your local MIS to the AE SaaS server
  - to be able to use TIFF Devices.

These Agent Containers are used in an [Agent Folder Access Point](#).

- **To receive files** from the AE SaaS server, typically data that should be output locally (proof, plate, press). Local devices can then pick up incoming jobs from such a folder (when they support such a basic 'hot folder' type of input).

These Agent Containers are used in the [Task 'Send File to Automation Engine Agent'](#) on page 1646

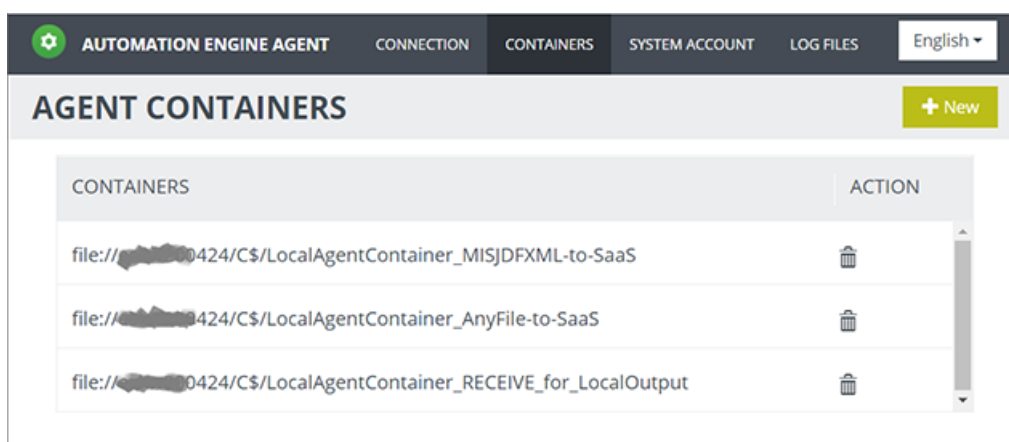

Click **+ New** to add an Agent Container.

- The folder URL can be set by typing in a path to a share in the local network. For example: `file://computername/foldername`.
- An error message will be shown when the entry is not valid.
- You can add multiple Agent Containers.
- To remove any from this configuration, click the trash can icon and confirm with **Yes**.

### MIS

Learn more in [Working with Agent Prefixes in JDF/JMF integrations](#) on page 1681.

### System Account

Agent technology is a Windows service ('EG Devices Agent') that is run by a system account that you define here.

### Log Files

Displays the Agent log files.

Typically, Esko support staff will check these type of files when needed.

Use the **Refresh** button to see live updates.

## 20.3. Extra Functionality in SaaS

---

Because the client and the SaaS server are in different networks, these tools have been developed to re-enable functionality that otherwise would not be possible (or not secure).

### 20.3.1. Agent Folder Access Point

When your Automation Engine server is a SaaS server (has that license), the type 'Folder Access Point' is replaced by a different one: **Agent Folder** Access Point.

Find a valuable instruction video in the course "AE SaaS - Agent Configuration for Administrators" on [Esko Blended Learning platform](#).

#### **Concept: Sending local files to the SaaS network**

When data are already within the AE Containers on the AE SaaS server, you can use many other tools to have AE actions done on those data.

The specific reason for this tool is that there are data on your local network that need some action on AE SaaS, which is not in your local network.

Typical examples:

- Some **data is created at your location**: A local system, for example the MIS system in your location, needs to transfer file data to AE SaaS. JDF or XML files can so create Jobs on your AE SaaS.
- Other **data arrives at your location**: For example customers send you files on your local FTP server, or via some physical medium arrives on your computer desktop, etc.). And these files also need to end up somewhere within the Containers of your AE SaaS server.



**Note:** An Access Point picks up files, not complete folders.



**Note:** Part of this use case can also be managed by using the [Drop File](#) functionality in My Workspace (browser client).



**Note:** In a Pilot client of an AE SaaS, the functionality to drop files onto folders in the Pilot or to use 'Explore' is not available.



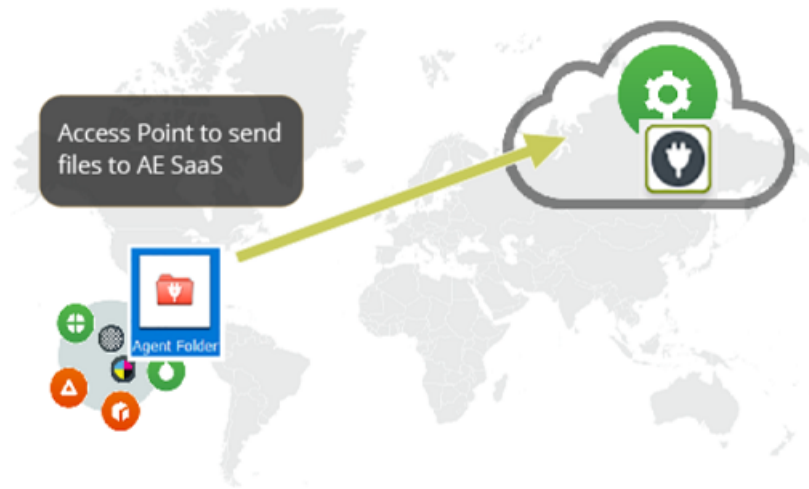

### Setup



**Note:** First make sure you have [set up](#) a local Agent and one or more Agent Containers.

- In the **Pilot** go to the **Access Points** view. Alternatively, choose **Tools > Access Points**.
- Click on . Alternatively, choose **File > New**.
- In the list of types, select **Agent Folder** and click **OK**.

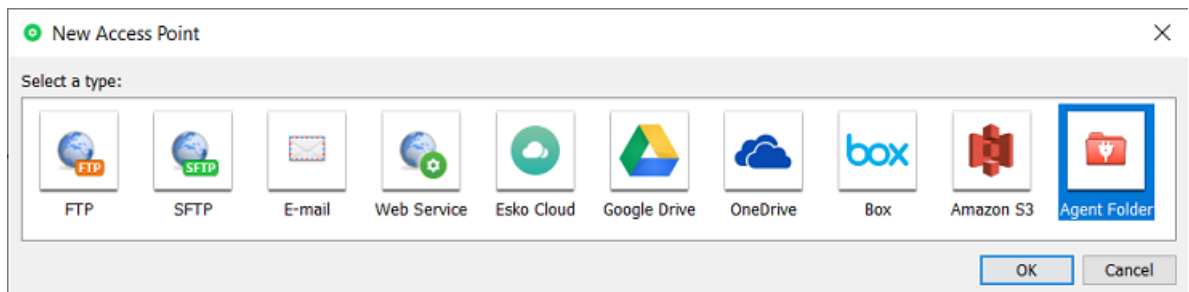

- The **New Agent Folder Access Point** dialog opens. An example:

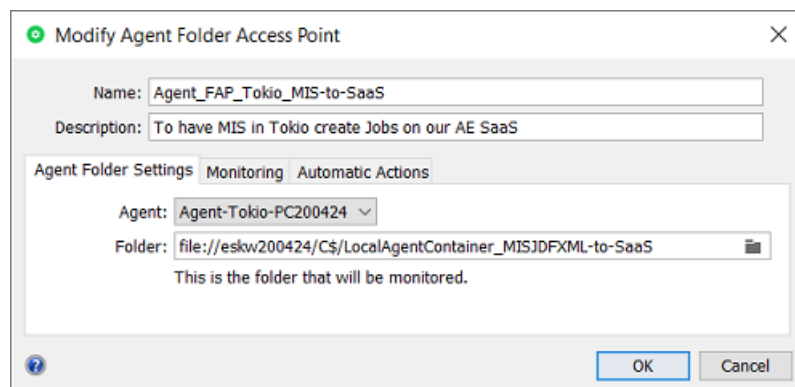

- Enter a **Name** for the **Folder Access Point**.
- Optionally, enter a **Description**. This helps to identify this Access Point without having to read all its settings.
- In the tab **Agent Folder Settings**:
  - **Agent**: Select your local Agent.
  - **Folder**: Define which local folder will be the actual Access Point that will be monitored by your Automation Engine SaaS (through use of the local Agent).

Use the browse button to select a folder (within one) of the configured local [Agent Containers](#).

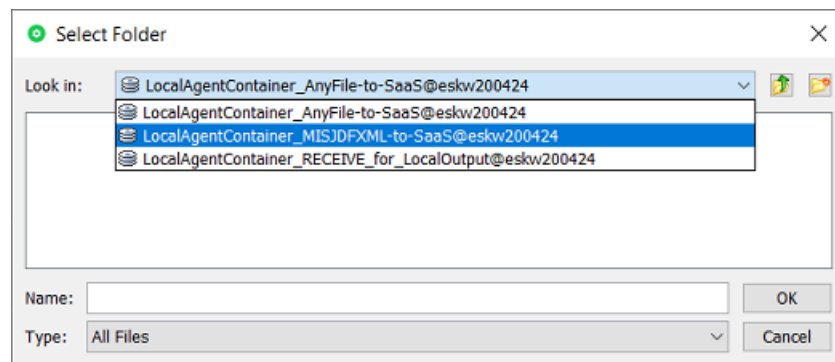

**Note:** This folder may not be used for any other Access Point.

- In the tab **Monitoring**:
  - **Check Every**. Enter the time interval with which Automation Engine should check if any new files came in. Think of the time interval as the *maximum* time it takes for the new files to be picked up.
  - **Schedule**. If you want this Access Point to be inactive during a part of the day, then activate this option and indicate the start and end time of that period.



**Note:** Such a temporary inactive state will not be shown in the general Access Points View. In that View, the column 'Active' shows its *general* status.

- In the tab **Automatic Actions**:  
Define what needs to happen when a file is detected.

- **Move Files to**: This is the folder where the files will be processed. These files have to be moved to avoid that the **Access Point** would process the same files again and again.



**Important:** If this destination folder is part of a Job Folder, the workflow that this access point launches will run in the context of that Job.

- **Rename Files to**: If you want you can choose to rename these files too. Typically, SmartNames are used here to help indicate in their name *when* they were processed or *where* they came from.
- **Action**:

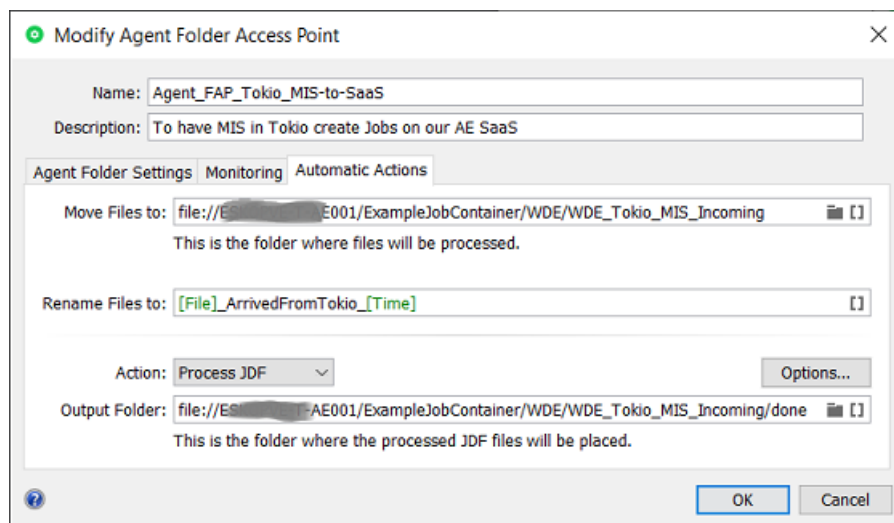

- **None:** Choose this option when you only want to use this Access Point to *move* the files to somewhere in an AE SaaS Container.
- **Launch Workflow:** Choose this option when you want a workflow to start. Select the workflow ticket from the offered list. The new accessed files will be used as input files for this workflow. If these files are inside a Job Folder, the workflow will be run in the context of that Job.



**Attention:** Make sure your workflow **can** start with the type of files that will arrive.

**Options:**

- **Operator:** Choose the operator that will be shown as operator for the workflow task.



**Tip:** If you do not want to assign one specific person, you could create an operator named "Access Points" or "Automatic" and assign that one here. Also remember that the Access Points Task Monitor shows you the tasks launched by the selected Access Point.



**Note:** If you leave this option blank, a system user "UPLC" will be used (referring to *UPLoad Client*).

- **Priority:** Choose the priority for this workflow: Low, Normal or High. The default priority is 'Normal'.
- **Process JDF:** Choose this option when this Access Point will be used to process incoming JDF files.
- **Output Folder:** Define where the JDF files should be placed once they were processed.



**Note:** Do not use this for XML files ; the JDF server behind this option will not process them. For XML files, select 'Launch workflow' and use the [Create Job task](#).

For more info on JDF, read this section: [What about JDF?](#) on page 1771.

### 20.3.2. Task 'Send File to Automation Engine Agent'

Find a valuable instruction video in the course "AE SaaS - Agent Configuration for Administrators" on [Esko Blended Learning platform](#).

#### Concept

Use this task to have Automation Engine SaaS send files (and folders) to a client location that has installed and configured an Agent.



**Important:** The data is copied, not moved.



**Important:** At the destination folder, identical files will be overwritten without warning.

Use this task for example at the end of a workflow by sending the (RIP'ed) output files to the location where they will be produced. i.e. being picked up by a proofer or CTP or press (some device that you could not configure as a local Device in the Pilot).



#### Task Settings

- **Agent:** Select the Agent in the target location.
- **Destination:** Select the folder, in one of the [local Agent Containers](#).



**Note:** It's possible to cancel the task while files are already transferring, however, their transfer will complete in the background anyway.

### 20.3.3. Adding a Local Device



#### Concept

Adding a Device (CTP Flexo, Digital Press, Kongsberg) is very similar to adding them as described for an on-premises Automation Engine.

Main extra is that you have to assign the name of the local Agent that will do the communication with the SaaS server.

Find valuable instruction videos in the course "AE SaaS - Agent Configuration for Administrators" on [Esko Blended Learning platform](#).

#### Specifics for Local Devices in a SaaS setup

1. First make sure that your location has set up [a local Agent](#).
2. In the Views bar, in the group **Setup**, open the view **Devices**.
3. Click , select the device category and click **OK**.
4. In the **New Device** dialog:
  - **Agent:** Click  and select your local Agent.

- **Server:** Type a name you will give to this local device.

After having clicked 'Add', open the info dialog of the device, in the field for **Server**, make sure to type in the name or the IP address of the front end computer controlling that local device.

5. Click **Add** to confirm. The colored status box of the newly created device appears.
6. Double click its status box to see or change any attributes.

Learn much more detail in the main pages on adding specific devices:

- Flexo CTP device: [Devices \(CDI\)](#) on page 1490 or [Devices \(TIFF\)](#) on page 1494
- Cutting Table device: [Devices \(Kongsberg\)](#) on page 1571
- Digital press (DFE) device: [Devices \(Digital Presses\)](#) on page 1589.

#### Outputting on the local Device

For a user, outputting on a local device is not different in a SaaS setup.

In the output tasks ('Submit to ...', ), select the **Device** that you added here, set its parameters and launch.

The task will also show you the feedback it gets from that local device.

## 20.4. Storing Inactive Jobs on Esko Cloud

### 20.4.1. Concept and Configuration

#### Concept

An AE SaaS setup requires that the AE Containers are also in that data center. However, data storage in a data center can become quite expensive.

Automation Engine SaaS customers that have an Esko Cloud account can also use it as a nearline storage. They can move Jobs to Esko Cloud where they are stored as **Inactive Jobs**.

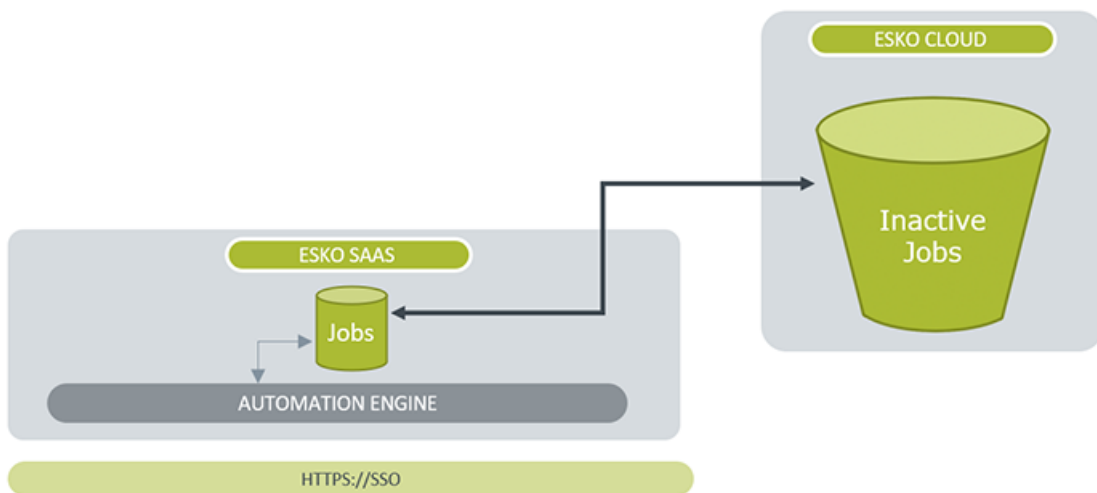

**Note:** Esko Cloud uses AWS S3 technology which stores data in 'buckets'.



**Note:** Another tool that uses Esko Cloud is Job Sharing, which is about temporarily sharing selected files from within a Job with an other Automation Engine on-premises location within your company group. Learn more in the chapter [Sharing to Collaborate with other AE servers](#) on page 1685.

Jobs can be moved back and forth by manual actions in the dedicated View (Pilot) or Gallery (browser) or by launching a task.

And also these tasks can be automated by being linked to an Access Point or started from external system, etc.

#### Configuration

An administrator of the SaaS setup sets this up in the Pilot's Configure tool.

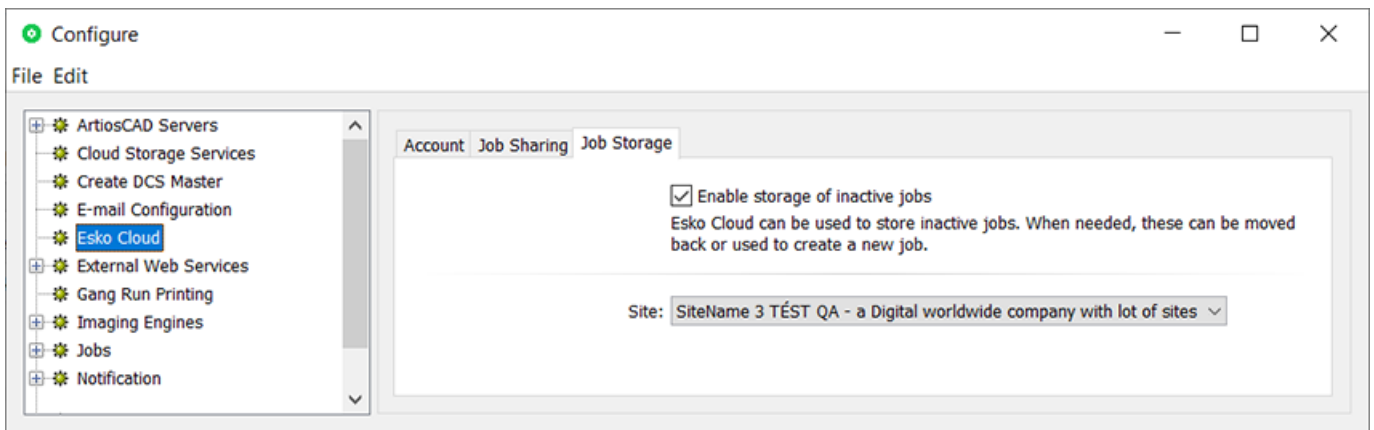

Once the Esko Cloud account is set up and signed in (learn more in [Esko Cloud](#)), select **Enable storage of inactive jobs** and select the Esko Cloud **Site** you will use for this purpose.



**Attention:** To avoid confusion, and also for performance reasons, it is strongly advised to set up the site for **Job Storage** on an different site than the site used for **Job Sharing**.

From now on, the Pilot will show the view 'Inactive Jobs'.

## 20.4.2. The View 'Inactive Jobs'

### General

 This view shows the inactive jobs that this location stored on Esko Cloud.

In the Pilot, it is part of the category of **General** views.

In [My Workspace](#) (browser client), it is shown in the page Jobs.

All functionality on inactive jobs is available in the Pilot or in [My Workspace](#). There is no specific reason to sign in to Esko Cloud and use the Esko Cloud browser interface.

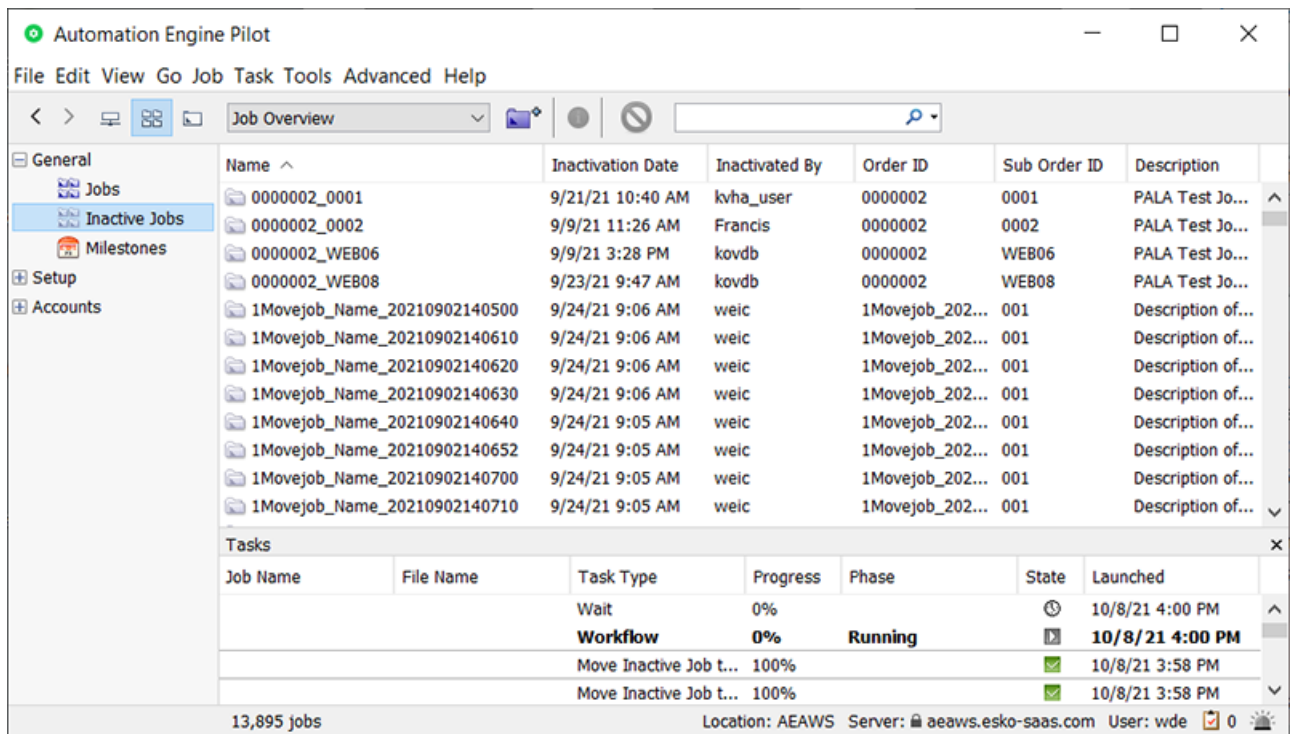

As usual, you can show or hide a selection of columns and you can re-arrange them.



**Note:** This view shows all inactive jobs for this Esko Cloud account. When multiple locations use that same Esko Cloud account, then this view will show jobs coming from these multiple locations. This is also why there is a column showing the name of the **Location**.

Within an Esko Cloud site, a job's path is formed as <Customer>/Jobs/<Location>%2F<job-name>. And the <customer> is prefixed with the name of the AE 'Equipment' that is used to access the cloud.

The total number of jobs is shown in the bottom bar. When scrolling down to the bottom of the list, you may notice that this view only shows the first 10,000 jobs. When there are more than 10,000, a message will inform you about this.

The view is not live. Use the usual shortcuts to manually refresh this view.

With this second view on Jobs, the search and filter tool offers an extra button to repeat this same search in the view Inactive Jobs, and vice versa:



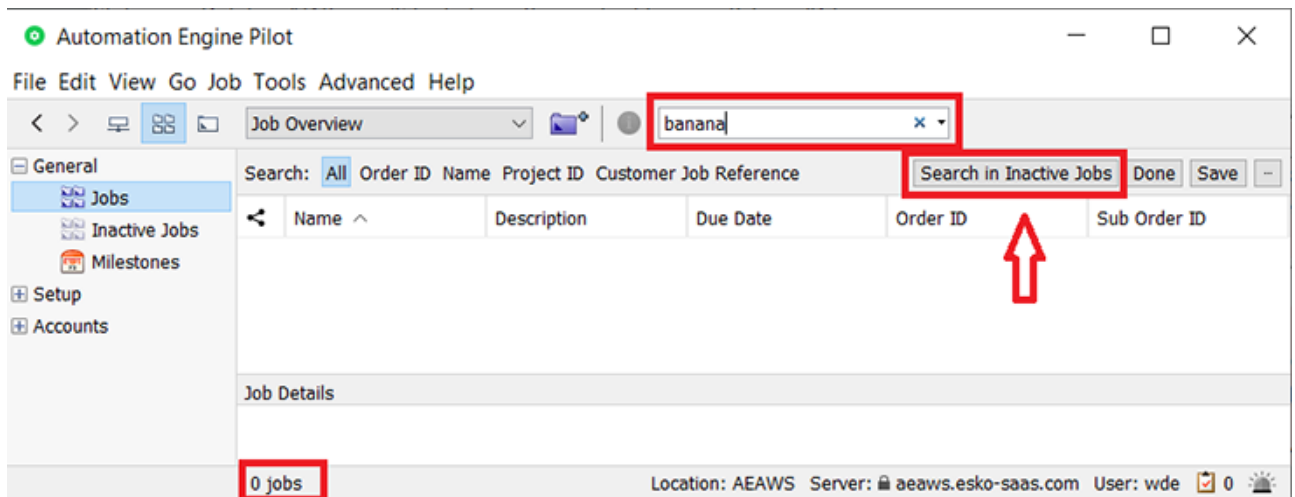

### Functionality in Jobs View

We will first mention the extra functionality in the classic **Jobs** view, as this is where it all starts.

Select one or more Jobs and (r-click or use the menu bar) and choose **Move to Inactive Jobs**. A dialog will ask confirmation before it launches the task **Move Job to Inactive Jobs** (1 task per job).



**Note:** *Shared Jobs* cannot be moved to Inactive Jobs.

The Job and its Job Folder content is moved out of the Container and moved to the near-line storage on Esko Cloud.

### Functionality in Inactive Jobs View

Functionality on selected Inactive Job(s):

- **Info:** The **Job Info** dialog shows all the available attributes. All fields are read-only.
- **Explore:** Shows the file contents of this inactive job. The dialog is read-only and the files cannot be opened
- **Move to Jobs:** Launches the task *Move Inactive Job to Jobs* on all selected inactive jobs.
- **Copy to Jobs...:** Opens a dialog where you must define a new unique name for the job. The **OK** button will stay disabled until a new was defined.

Click **OK** to launch the task *Copy Inactive Job to Jobs* on that selected inactive job.

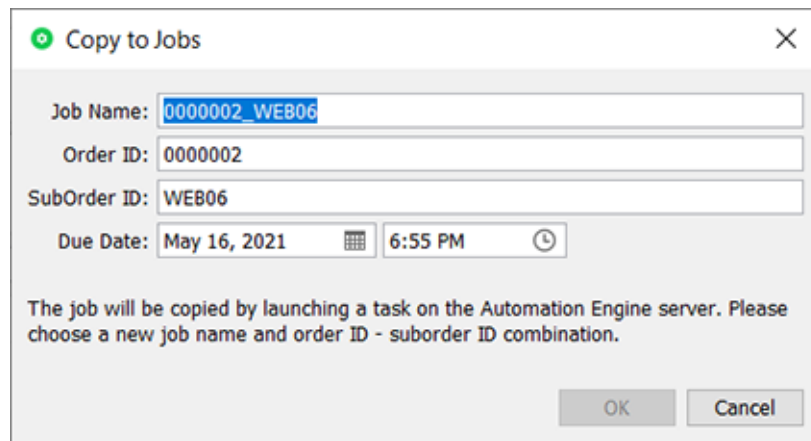

A dialog box titled "Copy to Jobs" with a close button (X) in the top right corner. It contains the following fields:
 

- Job Name: 0000002\_WEB06
- Order ID: 0000002
- SubOrder ID: WEB06
- Due Date: May 16, 2021 (with a calendar icon) and 6:55 PM (with a clock icon)

 Below the fields is a text instruction: "The job will be copied by launching a task on the Automation Engine server. Please choose a new job name and order ID - suborder ID combination." At the bottom right are "OK" and "Cancel" buttons.

- **Delete:** Launches the task *Delete Inactive Job* on all selected inactive jobs

### 20.4.3. Task 'Move Job to Inactive Jobs'



This task moves the selected Job(s) and all its attributes to the database of Inactive Jobs (on Esko Cloud). Once that is successfully done, it removes all that Job's entries in the local Jobs database and also its Job Folder.

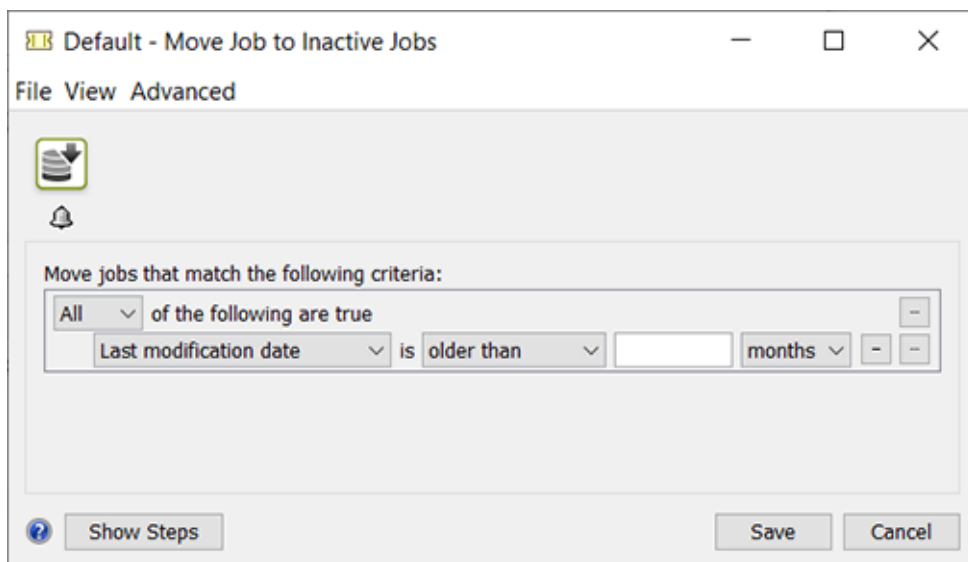

A configuration window titled "Default - Move Job to Inactive Jobs" with standard window controls (minimize, maximize, close). It has a menu bar with "File", "View", and "Advanced". Below the menu bar is a toolbar with a database icon and a bell icon. The main area contains the text "Move jobs that match the following criteria:" followed by a criteria builder:
 

- A dropdown menu set to "All" followed by "of the following are true".
- A row of criteria: "Last modification date" (dropdown), "is", "older than" (dropdown), an empty input field, "months" (dropdown), and two minus sign buttons.

 At the bottom are "Show Steps" (with a help icon), "Save", and "Cancel" buttons.

Some examples of criteria for job selection:

- **Last modification date** older than x days.
- Contains a **Job Parameter** x set to value y
- **Milestone** x was confirmed x days ago
- or a combination of the above.

- When the Job's Customer ID does not yet exist on Esko Cloud (IAM partner), it is automatically created.
- When the task is launched on multiple input files, any SmartNames it uses are resolved against the first input file.
- The task will fail in these situations:
  - when the Job does not have a Customer assigned (Customer ID).
  - when the Job does not have a Job Folder assigned.
  - when there is already an Inactive Job with that same Job Name or with a same combination of Order ID and SubOrder ID.
  - when the Job is marked for Job Sharing. Learn more in [Sharing to Collaborate with other AE servers](#) on page 1685.

### 20.4.4. Task 'Move Inactive Job to Jobs'



This task creates the selected Inactive Job(s) on the local Jobs database with its same Order ID, SubOrder ID, Name, Creation Date, Due Date (the original dates), ... Also its Milestones are restored (with new calculated timings). Once this is successfully done and all files are downloaded, the Inactive Job on Esko Cloud is removed.

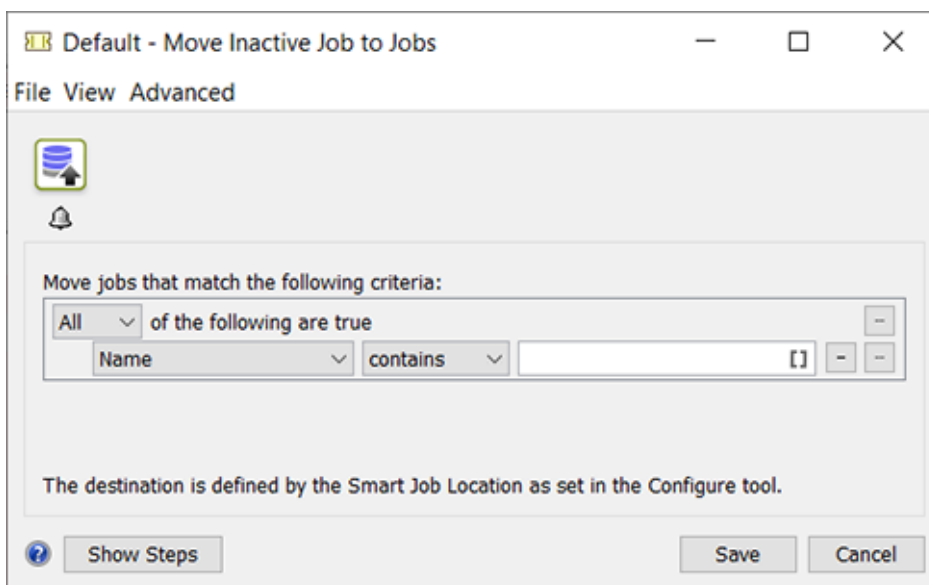

The target location for the Job Folder in an AE Container is defined by **Smart Job Location** rules that an administrator set up in the Pilot's Configure tool. Learn more [here](#).



**Attention:** For this to work, make sure that the Smart Job Location rules are specified in terms or SmartNames using only Job attributes (like `job.orderid`, `job.customerid`, `job.customerdescription`, ...).

When, for example, SmartNames are used that refer to some input file (directly or indirectly), this will lead to an incomplete or unusable path for the Job Folder.

- The task will fail when a local Job with the same Job Name or a same combination of Order ID and SubOrder ID already exists ; it will not overwrite such a same Job.
- When there is no local Customer ID yet that corresponds to the one of the Inactive Job, it will be created automatically on the local database.

### 20.4.5. Task 'Copy Inactive Job to Jobs'



This task *copies* an Inactive Job to the local Jobs database. You typically do this when the Inactive Job has files or specifications that you want to re-use in a new Job.

However, to avoid that a Job with a same Name or combination of Order ID and SubOrder ID exists in 2 places (as a local Job on AE and also as an Inactivated Job on Esko Cloud), the task requires you to define a new unique name.

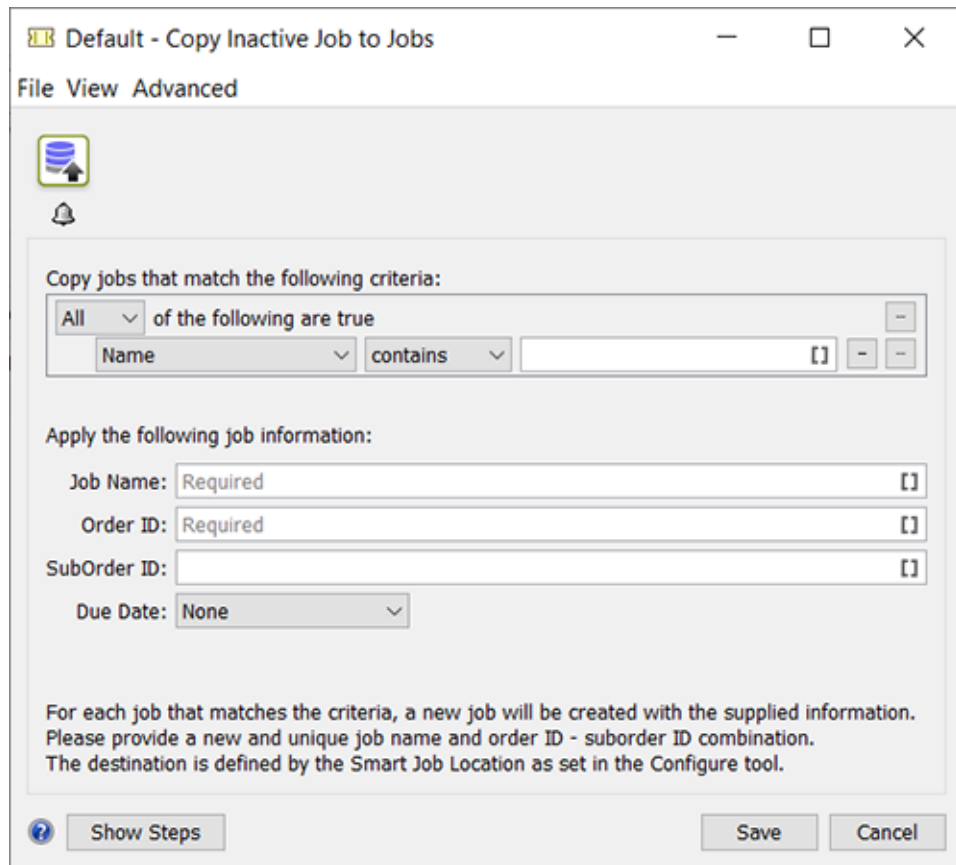

The task will fail when these options do not result in a new unique Job Name or combo or Order ID and Suborder ID.

The SmartNames Order ID, SubOrder ID, Name and Due Date can be used: these are resolved to the attributes of the Inactive Job. .

SmartNames relating to job parameters or job inks can not be used (are not available).

About the new Job's time-related settings:

- The **Creation Date** is set to the current time (when this task runs).
- The **Due Date** is set as specified in the task options.
- The Job's **Milestones** are not restored.

### 20.4.6. Task 'Delete Inactive Job'



This task deletes the selected Inactive Jobs from that database on Esko Cloud.

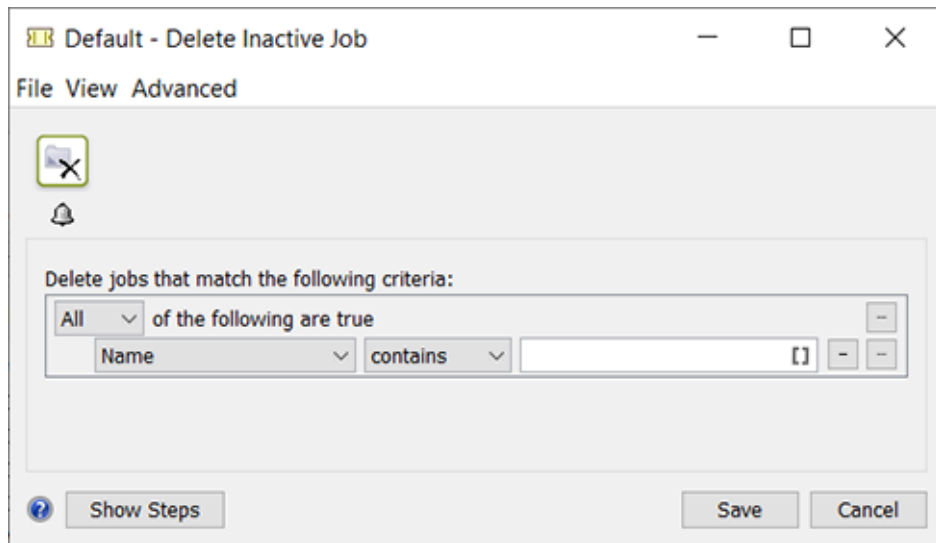

## 20.4.7. Automating the moving of Jobs

### Example: A Smart View with Jobs that are ready to be Inactivated

1. When is it time to move a Job to the cheaper storage? One example could be that you want to move that data away from the SaaS data center 3 months after the Job was 'done' ; or one month after your MIS confirms its 'archive' state because the finance department confirmed in the MIS that the bill for that Job was paid.
2. Whatever your custom timing is, you can set a dedicated Milestone for that Job, for example the Milestone 'Ready to Inactivate'. Learn all about Milestones in [Milestones: Tracking Job Status](#) on page 568.
3. Make a Smart View of the Jobs view that only shows jobs which have that milestone confirmed. Learn about Smart Views [here](#).

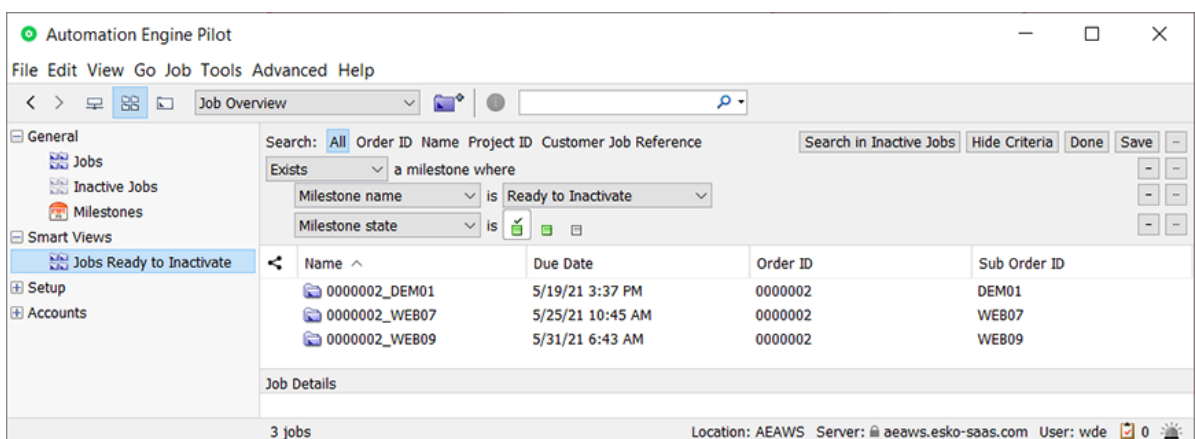

4. Make a selection and launch a workflow ticket that contains the [Task 'Move Job to Inactive Jobs'](#) on page 1652.

**Note:** A limitation in the current version requires this task to be part of a workflow ticket ; using the single task will only move the first in the selection.

**Example: An Access Point checking a Job's Milestone**

This starts the same way as above: Jobs having a Milestone that confirms they are ready to be moved away to Esko Cloud.

In this example we automate this by using an Access Point that, once a week, will launch that moving as a scheduled task.

1. Create the workflow that the Access Point will launch - an example:

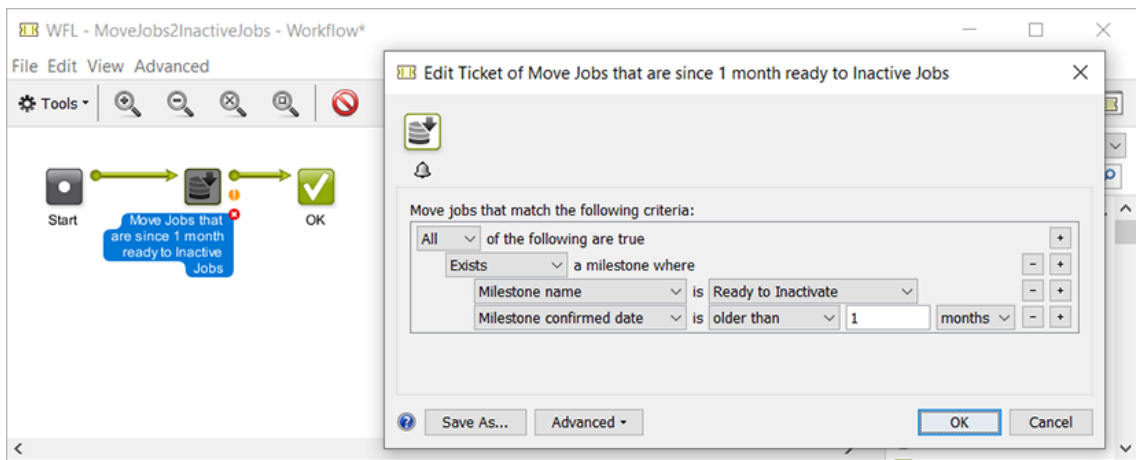

2. Create the Schedule Access Point - an example:

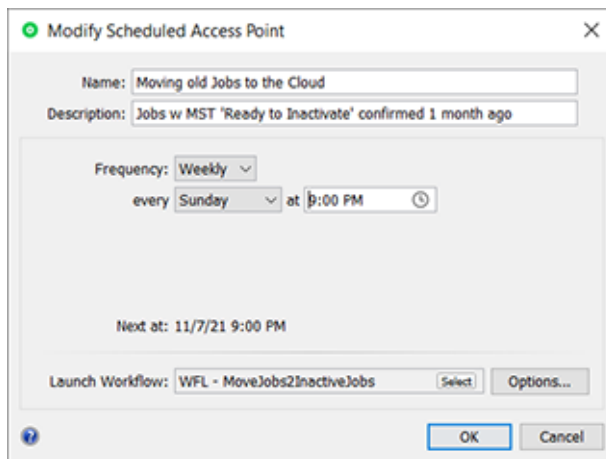

## 20.4.8. Task 'Change Location of Inactive Jobs'

The term '**Location**' here refers to the concept of data-filtering as explained in [Filtering on Locations after consolidating all data](#) on page 1676.

In a setup where you decided to use this Location attribute for Jobs, you might start with many Inactive Jobs that do not have this attribute set yet.

This task enables to set (or update) this location attribute for all Inactive Jobs that match the filter defined in the task ticket.

You can not start this task by first selecting a set of Inactive Jobs ; this selection is built into the task itself.

1. Make a task ticket with the wanted filtering of inactive jobs.
2. In the Workflow Editor, add this ticket to a workflow and save this workflow.
3. Launch this workflow (from within the editor or later for example as a favorite ticket).

## 20.5. Storing Products on Esko Cloud

---

### 20.5.1. Concept and Configuration

#### Concept

When working with [Products](#), an AE SaaS setup also requires that they are stored within an AE Container, which means in the data center. However, data storage in a data center can become quite expensive, especially for Product related data, which conceptually represents long term data and probably the largest amount of data you may have.

Products and their data are kept until you are sure that you will never have to produce them again, or that you will never need their data as basis for some new variant.

Automation Engine SaaS customers that have an Esko Cloud account can also use it as a nearline storage. They can move or copy Products and their Product Data Zone to Esko Cloud and back.

It is also a lot easier to scale up storage on Esko Cloud than in a data center.

On Esko Cloud, Products are read-only. To use them actively, you need to (temporarily) bring them back to Automation Engine.



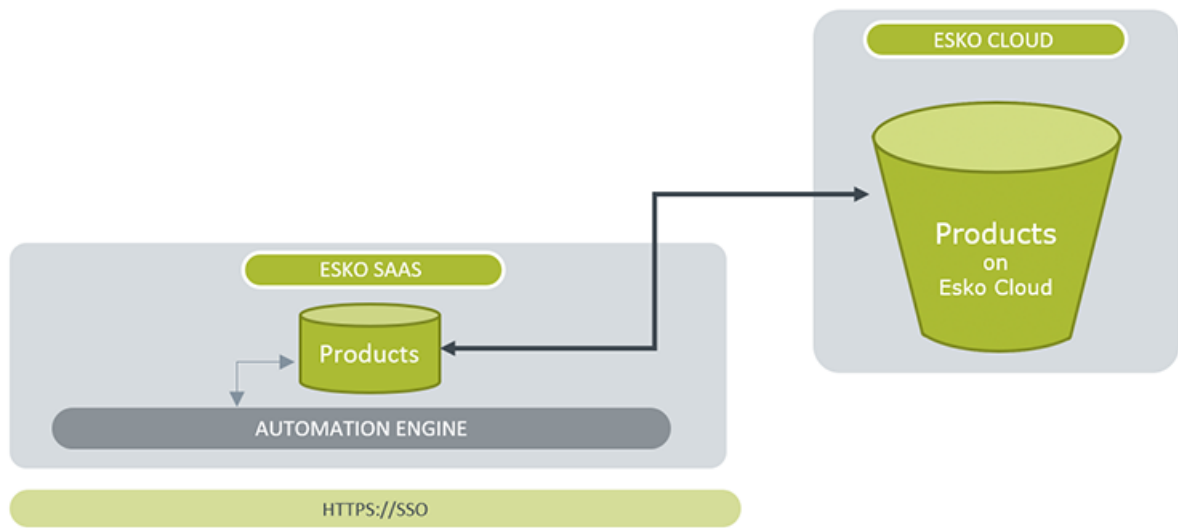

**Note:** Esko Cloud uses [AWS S3](#) technology which stores data in 'buckets'.

Products can be moved back and forth by manual actions in the dedicated View (Pilot) or Gallery (browser), or by launching a task.

And also these tasks can be automated by being linked to an Access Point or started from an external system, etc.

### Configuration

To be able to store Products on Esko Cloud, you only have to set up a link to Esko Cloud in **Pilot > Configure > Esko Cloud > Product Storage**.

This [configuration](#) is very similar to the one for storing [Jobs on Esko Cloud](#).

The steps to follow are identical as described in [Initial Configuration](#) on page 1690 (in the chapter [Sharing to Collaborate with other AE servers](#) on page 1685).

## 20.5.2. The View 'Products on Esko Cloud'

### General

This view shows the Automation Engine Products that this Automation Engine uploaded to Esko Cloud.

In the Pilot, this view is part of the category of **General** views. In [My Workspace](#) (browser client), it is shown in the page **Products**.

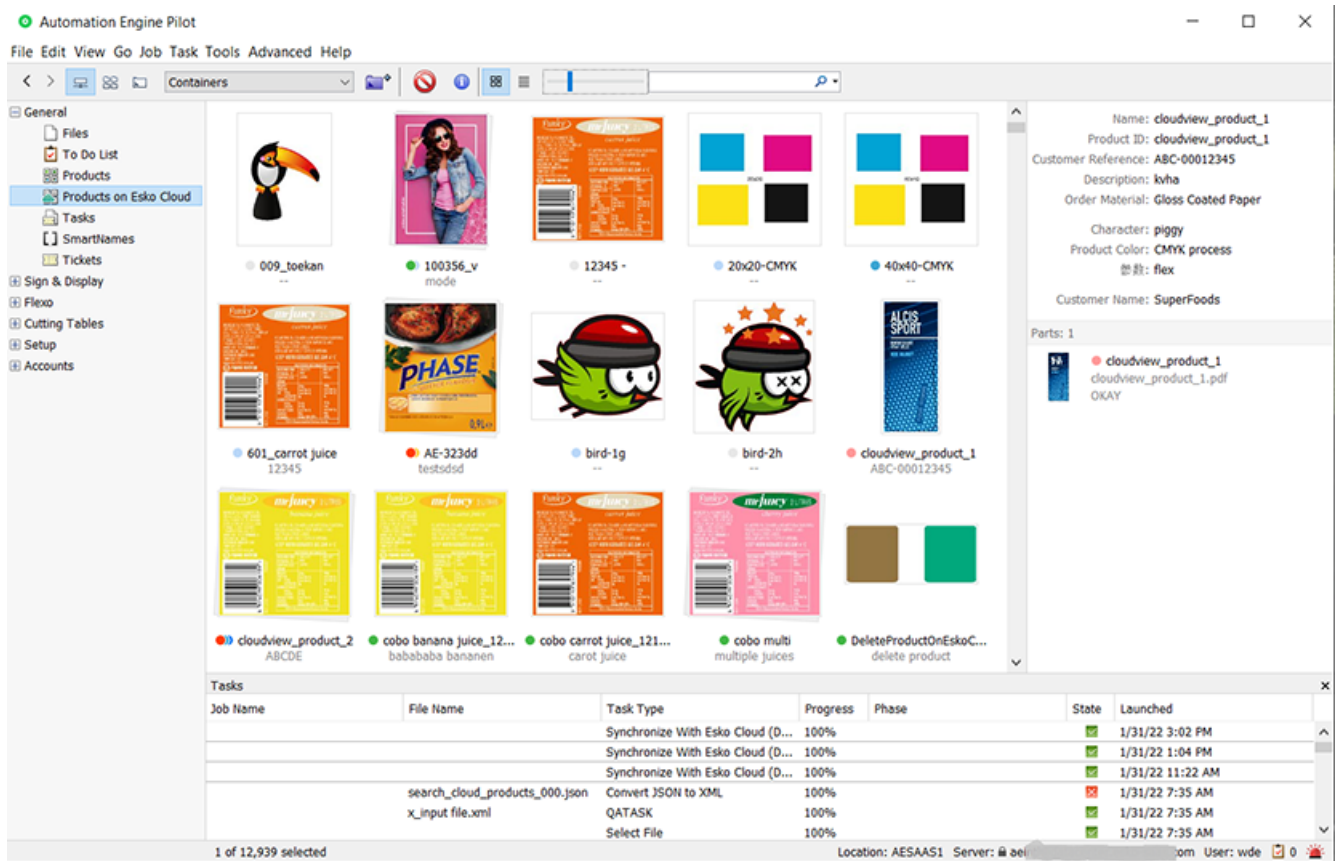

As with Inactive Jobs, all functionality on Products on Esko Cloud is available both in the Pilot and on My Workspace. There is no specific reason to sign in to Esko Cloud itself and use that Esko Cloud web interface.



The total number of products is shown in the bottom bar. When scrolling down to the bottom of the list, you may notice that this view only shows the first 10.000 products. When there are more than 10.000, a message will inform you about this.

This view is not live. Use the usual shortcuts to manually refresh this view.



**Differences between this view and the 'Products' view:**

- In the top bar of this view:
  -  A delete button. You will be asked to confirm.
  -  Use the slider to change the size of the icons.
- The status of a product is indicated by a small colored circle. When you see more than one circle, this means that not all product parts have the same status. Maximum 3 such small circles are shown in this view.

Learn more about the status of a product in [Products Views and Menu](#) on page 605.

- The icon of a product with multiple parts will indicate this with a tilted shadow:



- Control of view options: Right-click anywhere in the products gallery and select **Show View Options...**
  -  When the gallery is in **icon** mode:
    - **Sort by:** By default, products are sorted by name. You can select a different method.
    - **Order:** Select if the sorting is done **Ascending** or **Descending**.
    - **Icon Size:** Use the slider to set the wanted size of the icon.
    - **Info:** The information shown underneath the icon can be customised. Select how many lines of info should appear below the icon. Then select what should be shown in those lines.
    - **Show status:** By default, a small colored circle underneath the preview indicates the product's status. You can switch this off.
  -  When the gallery is in **list** mode:
    - **Icon Size:** Select if you want a **Small** or **Large** preview icon.
    - **Show icon:** By default, the column with the product's name also shows a small icon. You can switch this off.
    - **Show status:** By default, the column with the product's name also shows its status. You can switch this off.
- The right-side panel shows details on the selected product. This example shows a product with 2 product parts:

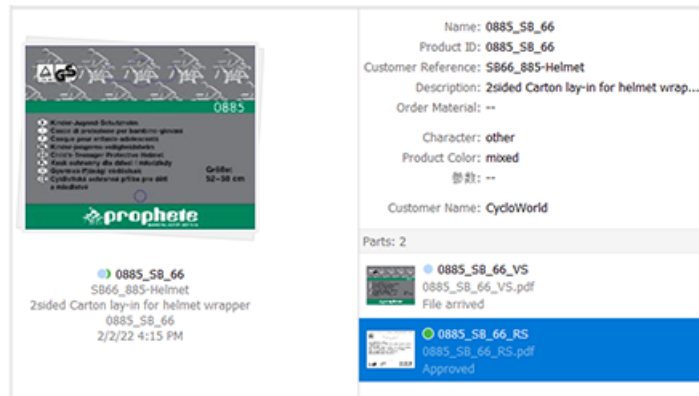

**Tip:** To see further details of one of the product parts, double click its icon to see an extra info dialog.

### Related Functionality in the other View showing the LOCAL Products

Because this is where it all starts, we here first mention the extra functionality in the classic **Products** view.

- In the view 'Products', select one or more products and (right-click or use the menu bar) and select **Upload Product to Esko Cloud...**. A dialog will ask confirmation before it launches the task [Upload Product to Esko Cloud](#) (1 task per product).



**Note:** Only [global products](#) can be uploaded to Esko Cloud. This task fails when you launch it on a Job Product. Your only workaround to upload a Job product is by first removing the Job, which will also remove the product (not the data). Then re-create the product as a global product.

- Option: **Remove local product after upload**
  - When **selected**: After a successful upload to Esko Cloud, the local product and its complete data zone will be deleted.



**Attention:** Make sure that these product data zones do not overlap with data zones of any other products!

- When **not selected**: The local product remains in the local AE database of Products and its data zone is also untouched.

### Functionality in the View 'Products on Esko Cloud'

Select one or more products and right-click (or use the menu bar) to discover the available functions :

- Info:** The **Product Info** dialog shows all the available attributes. All fields are read-only.



**Restriction:** In this dialog, not all customer related attributes are shown. Still, they are stored and will re-appear when downloading this product again.

- Explore:** This dialog shows the content of the Product Data Zone on Esko Cloud. .

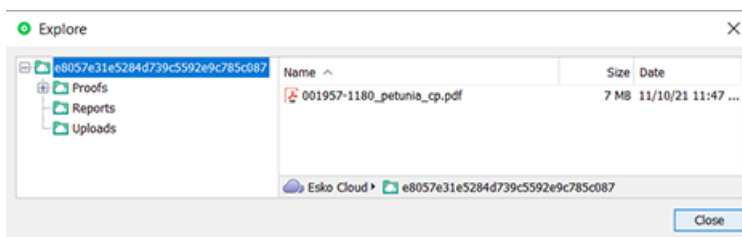

**Note:** While it is stored on Esko Cloud (using AWS buckets data system), the root folder or the Product Data Zone has a name using a unique ID.

The dialog is read-only and the files cannot be opened. However, there is one function available in this dialog: make a file selection, right-click and choose **Save to Downloads Folder**. This saves a copy of these files in to the 'downloads' folder on your local client computer.

A typical use case would be to download only a product's external image to be used in a new variant of that product.

- **Download...:** Launches the task [Download from Esko Cloud](#) on all selected products. It will create the product on Automation Engine and download the product part files.
- **Download complete Data Zone:** Select this to not only download the product part files but its complete data zone.



**Restriction:** When you want to download more than 100 products, we advise to use one of these alternatives:

- In this view, create a filter, then select all the results, and then choose 'Download...'. Or, for example in the Tickets view, open a ticket of this download task, then define your selection via the filter in the ticket, and launch the task from there.

- **Delete:** You will be asked to confirm. Click **OK** to launch the task [Delete Product on Esko Cloud](#) on the selected Product(s).

All related data on Esko Cloud will be deleted.



**Note:** As mentioned above, this view in 'My Workspace' (browser client) does not allow a user to delete or change a Product.

### 20.5.3. Task 'Upload Product to Esko Cloud'



Learn about uploading products to Esko Cloud in [The View 'Products on Esko Cloud'](#) on page 1659.

This task ticket offers a filter to define the products to upload.

- **Remove local product after upload and delete its data zone:**



**Attention:** Make sure the data zone does not overlap with the data zone of other products. Even in that case, it will still be deleted!

When the product is already on Esko Cloud, the task will overwrite the data on Esko Cloud.

When the local product has no customer specified, the task will fail.

These data zone subfolders are not uploaded: ".metadata", ".view" and ".dip".

## 20.5.4. Task 'Download Product from Esko Cloud'



### Concept and Task settings

Learn about downloading products from Esko Cloud in [The View 'Products on Esko Cloud'](#) on page 1659.

This task ticket offers a filter to define the products to download.

Downloading a product does not remove it from Esko Cloud. When that is what you want, use the dedicated [Task 'Delete Product on Esko Cloud'](#) on page 1665.

- **Download complete Data Zone:** When selected, the task will not just download the product part files but the complete data zone.
- **Overwrite existing local product:**

When selected, existing local products are overwritten, otherwise an error is generated.

An existing local product is defined as either

- a local product with the same Name as the product on Esko Cloud, or
- a local product with the same Product ID as the product on Esko Cloud, or
- a local product with the same internal ID as the product on Esko Cloud (e.g. upload first without deleting the local product, then change name and product id of the local product, and then download again).

When overwriting a product,

- The local product links are kept: i.e. the overwritten product has the same links to a Job and the same amounts.
- When uploading the overwritten product again to Esko Cloud, it overwrites the existing product on Esko Cloud.

This tool for example allows that an MIS initiates the creation of a product in AE's Products DB and that afterwards the MIS uses this task also instructs to bring back the actual PDF from Esko Cloud (and all other product parameters).

This is especially interesting in an MIS-integrated (JDF) workflow where you work with re-prints.

### Example use case

An MIS could be the first system to know that a product is going to be needed again in (prepress) production. It can send the command to Automation Engine (XML/JDF...) to launch this task on that required product.

Learn about system integration in the chapter [Integrating with External Systems](#) on page 1769.



**Note:** An external system can not access a product directly on Esko Cloud.

**Where in the AE Containers is the new Product created?**

- When the product **already exists** as a local product, the downloaded data and properties will overwrite all the local data in its existing product data zone.
- When the product is a **new** local product, it will be created as a local product and the destination of all data is decided by the Smart Product Location rules. Learn more in [Products Data Structure](#) on page 599 and in [Smart Product Location](#) on page 238.

**What happens to Modification Dates?**

The modification dates of the transferred files do not change.  
As a result, for example the SmartID of a file remains the same.

**What happens to Custom Statuses?**

When you download a product that has a custom made status, and this custom made product status does not exist (or no longer exists) on Automation Engine, then this status will be kept for that product, but only its name, not its custom color or icon (you can re-add those attributes afterwards).

**20.5.5. Task 'Delete Product on Esko Cloud'**



**Concept and Task settings**

Learn about storing products to Esko Cloud in [The View 'Products on Esko Cloud'](#) on page 1659.  
This task ticket offers a filter to define the products to delete.  
This task deletes the product on Esko Cloud and also deletes all its related files on Esko Cloud.

**20.5.6. Task 'Change Location of Products on Esko Cloud'**

The term '**Location**' here refers to the concept of data-filtering as explained in [Filtering on Locations after consolidating all data](#) on page 1676.

In a setup where you decided to use this Location attribute for Products, you might start with many Products that do not have this attribute set yet.

This task enables to set (or update) this location attribute for all Products that match the filter defined in the task ticket.

You can not start this task by first selecting a set of Products on Esko Cloud ; this selection is built into the task itself.

1. Make a task ticket with the wanted filtering of Products on Esko Cloud.
2. In the Workflow Editor, add this ticket to a workflow and save this workflow.
3. Launch this workflow (from within the editor or later for example as a favorite ticket).

## 20.6. Using Esko Cloud for Color Data

---

### Concept

Using Esko Cloud for color data implies that your Automation Engine uses color data that are present and managed on your Esko Cloud site. The central color data base (used by applications like Color Pilot, ArtPro+, etc.) is then the one on Esko Cloud.

Advantage of having your color data on Esko Cloud is that it becomes available to (be managed by) many more users, possibly from different locations.



**Note:** Technically, the central color database on Esko Cloud will be synchronized and cached locally, so that the access happens faster. This background process is done by a dedicated service named 'CRD service' (Cloud Resource Downloader).

### Important Warnings and Restrictions



**Caution:** The following data managed by Color Pilot can NOT YET be uploaded to Esko Cloud:

- Curves of all types, PressSync curves, DGC, ...
- Screens
- Printing Conditions
- Digital printing strategies using a Black Generation preset
- Digital printing strategies using a DGC curve
- Proofing strategies using a DGC curve
- Digital press configurations
- Ink Limitation sets
- Overprint charts

Customers who make use of these data types will after switching to Esko Cloud no longer be able to manage (via Color Pilot) these types of data located in the SaaS data center. It is strongly discouraged for these customers to move to Esko Cloud.



**Restriction:** On Digital Front End setups:

- The HP Production Pro 8.2 or higher supports Esko Cloud objects but you must contact HP Support for the installation of Color Pilot 23.07 (or higher).
- The DFE (HP, Epson and Esko) does not support Esko Cloud data.

### Advantages

- Standards are globally available in the cloud. There may be multiple instances of AE SaaS but there is only one Esko Cloud.
- Local data like press configurations and HP Spot Master refinements remain in the local on-site databases. Sites can combine global and local data.
- The Syncer application is no longer needed for color data. No more local caches & syncing per client computer except for the home office.
- Data objects can be simultaneously edited. Conflicts are signaled and can be resolved at upload time.



- Access rights management + sharing of color database objects even outside your company.

Learn more below about [Preparation and Configuration](#) on page 1667.

## 20.6.1. Preparation and Configuration

### Preparation



**Important:** In the background, the CRD service caches the Esko Cloud color data locally on the AE SaaS server. This does include the overwriting and even deleting of color data that was there before you enabled to use Esko Cloud as central color database.

Before enabling this configuration, first make sure that

- You have **Backups**:
  - Your Automation Engine SaaS server has a recent backup of your color data. Learn how in [Backup](#) on page 2020.
  - Your Color Pilot has a recent backup of all the data it manages. This can be done by a Color Pilot connected to AE SaaS. A summary of what to do in Color Pilot:
    - Choose **File > Export Library**
    - Select **Include screens, curves and printing conditions**
    - Give the archive a name and choose a folder to store it
    - Click **Export**.
- You have **moved** all your necessary color data to your Esko Cloud site. This is also done by using your Color Pilot. Learn how in the [Color Pilot user guide](#): See **General Config > Servers > Esko Cloud** and also in **Working with Esko Cloud > Uploading Color Data to the Cloud**.

### Configuration in Pilot > Configure

After this preparation,

- • Go to **Pilot > Configure > Esko Cloud > Color Data**.

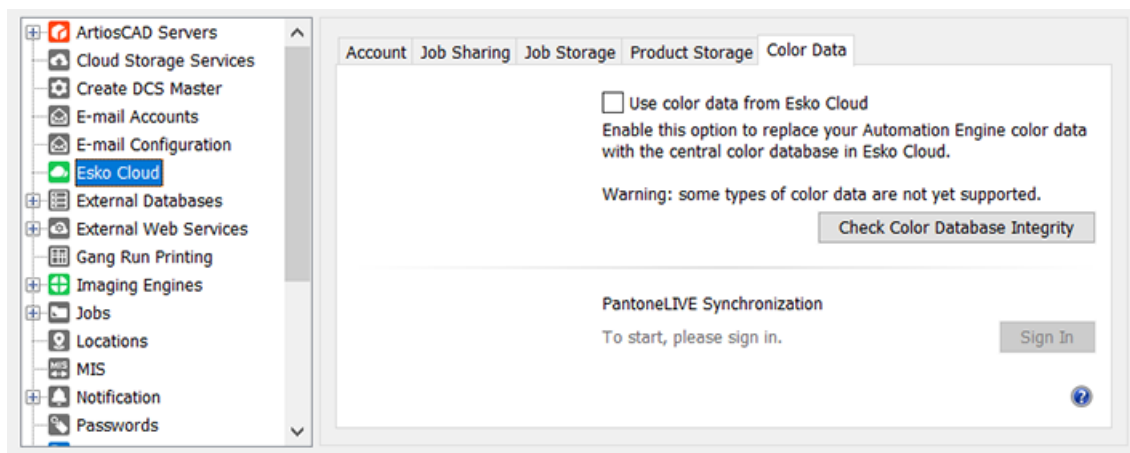

- Before continuing it is good to click **Check Color Database Integrity**. This tool checks if your color database is consistent, if nothing is out of sync, if files have no missing links. This quick check either results in an OK message or shows a warning message (and offers to save the technical report of this check). Know that strategies with integrity issues are already not shown in lists in Esko applications. Use Color Pilot to address any integrity problems.

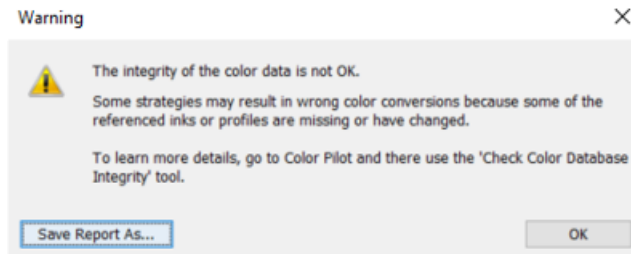

**Note:** You have the same tool in Color Pilot. The report is easier to read there.

- **Use color data from Esko Cloud:** Select this when you finished the important preparation steps and are aware of the current restrictions.

You will be asked to confirm. Read the warning message carefully.

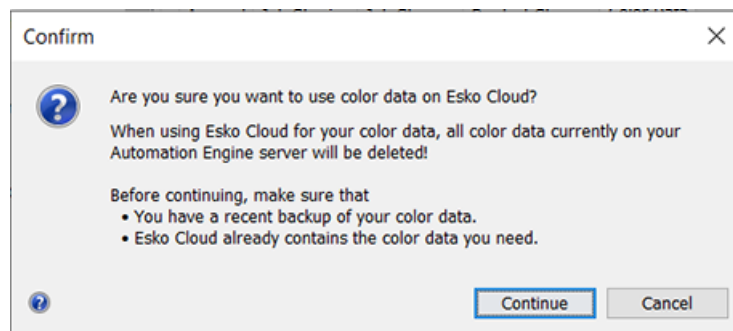

- Click **Cancel** when you did not yet make a backup in Color Pilot AND you are using any of these unsupported file types:
  - Screens, Curves or Printing Conditions
  - Digital Printing strategies using a DGC and / or Black Generation preset
  - Proofing strategies using a DGC.
- When you click **Continue**, AE analyses the color data in the data center. In case there are custom color data that in this version can not yet be uploaded to Esko Cloud, you will get a second warning mentioning this risk of losing data.
  - When you now click **Continue Anyway**, these events will happen:
    - All custom color data will be deleted (without first taking a backup).
    - A Color Pilot connected to AE SaaS will no longer be able to open the lock to edit color data in that data center.
    - The AE server starts the 'CRD service' (Color Resource Downloader) and will keep it perpetually running. This service mirrors the color data on Esko Cloud to the color

database in the data center, so creating a cache that is instantly available for AE and the local applications.

- Deselect **Use color data from Esko Cloud** when you want to switch back from using the color database on Esko Cloud to using the color database on your AE SaaS server. This triggers these events:
  - The CRD service is stopped gently. Any ongoing downloads will first be finished.
  - The CMS database in the data center will remain as it is at the moment the CRD service stops. This the latest cached data. Your downloaded color data, both Esko and PantoneLIVE, will remain in the database.
  - Changes in Esko Cloud or PantoneLIVE will no longer be synchronized to the color database in the data center.
- **PantoneLIVE Synchronisation:** In case you have a PantoneLIVE account you can **Sign In** to PantoneLIVE by specifying the credentials.



**Note:** Why is this needed? When AE SaaS is used for color data (when its 'CRD service' is running), Color Pilot no longer has access to the AE SaaS CMS database. This means it is also no longer possible (using Color Pilot) to download PantoneLIVE ink books from the PantoneLIVE cloud to the AE SaaS CMS database. That why you here have to enter the PantoneLIVE account so that the CRD service can download the PantoneLIVE ink books into the AE SaaS CMS database.

By this sign in, AE SaaS (the CRD service) is triggered to download all the PantoneLIVE libraries (that you have the right to see) to the color database in the data center and keep them up-to-date at that location.

**Force Synchronization:** Because of the static nature of PantoneLIVE, AE (the CRD service) only checks the PantoneLIVE libraries every 30 minutes. If you want AE (the CRD service) AE to start synchronizing immediately, then click **Force Synchronization**.

### Special UAR needed when using Color Pilot

On a SaaS server, the list of [User Access Rights](#) contains this extra one:

- **Color Pilot: create/modify/delete (Colors, Curves and Screens):** This one is required when a Color Pilot user wants to make changes to a color database of an AE SaaS server. The lock icon can not be opened without this specific right. Learn about the limitations of the read-only mode in the [Color Pilot user guide](#) (**General Config > Database > Working with a DB in a Data Center > Read-Only Mode**).

## 20.7. Editor Connection Tools

---

### 20.7.1. The App Launcher Tool (SaaS + On-Premises)

Opening files from within a browser client is possible both in SaaS as in on-premises setup. To the user, its functionality is identical.

See its description in the chapter on the browser client, in [Opening Files from the Browser Client](#) on page 894.



**Note:** App Launcher communicates with Syncer: When a user requests to open a file,

- the App Launcher first informs the Syncer that that file is not yet in the local cache of the user's workstation and so that the syncer needs to copy it over from the AE SaaS Container.
- Right after that it asks the user which local application should be used, or immediately opens the file in the default local app (as soon as the sync is done).

## 20.7.2. The Syncer Tool

### Concept

The Automation Engine Syncer tool allows users to work with a local synced copy of files and folders that are located in a SaaS data center, aka a mirror data set. When you open such a file on your local workstation, the Syncer will first sync the file from the data center to a local cache folder and only then that cached file will open in your local application.

When the user modifies the contents of the local mirror (i.e. adding, removing or modifying files and folders), the same modification is applied to the corresponding files and folders in the data center.



**Note:** When both the local file and the version in the data center has changed, a conflict is detected and a warning shown. Learn more below.

The Syncer is only aware it has do something when the opening of the file is done via any of these tools:

- **Clients:** AE client (Pilot or browser client)
- **Editors:** ArtPro+ and DeskPack (Adobe Illustrator + Esko plug-in)
- **Resource editors:** Color Pilot, Curve Pilot, PitStop Profile editor.



**Note:** Learn more below on what happens when the local applications are Esko classic editors (PackEdge, ArtPro, Plato / i-cut) or non-Esko applications (Acrobat, Photoshop, ...).

Also resource files are being sync'd. Calibration resources (CMS, DGC, screens, profiles) consist of multiple files and to avoid data corruption, any edit and upload action is protected by locking flags. There is no automatic upload of modifications, the upload is under control of the editing application.

When starting up (and signing in to AE SaaS), the syncer already syncs these resource files ; there is no reason to wait until the user opens a first PDF file.

### Cache Folder Location and Warnings

This is the default (and automatically created) location of a local cache is on the client, in a hidden folder in the users' home directory:

- ~/AESYNC (macOS)
- %USERDIR%\AESYNC (Windows)



**Note:** This is a folder on each local workstation. This is not one folder for all workstations.



**Danger:** It is strongly dis-adviced to make any manual changes to these folders. There are no foreseen reasons to do this. Any manual deleting of data in this cache will show a warning that the local files were deleted and will ask you to confirm if you ALSO want to remove the equivalent data in the data center!

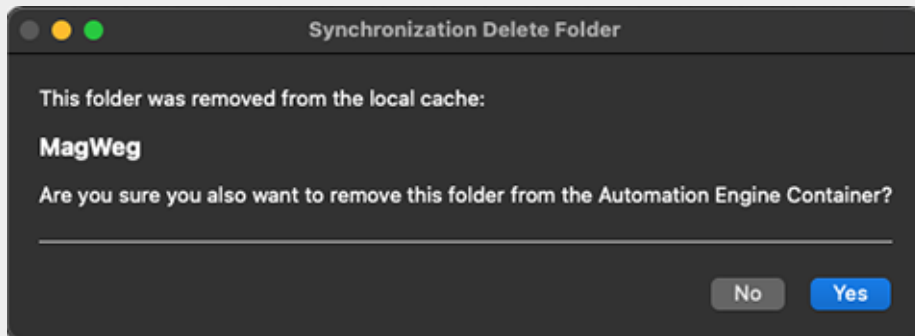

Also, if someone opens a file directly from the local cache, then it is quite possible that you open an outdated file. For example: Applications that are not integrated with the Syncer (\*) and that show a list of 'Recent files' that you opened: be aware that - to that application - those 'recent files' are files in the local cache, not the source files in the AE SaaS data center! (\*): PackEdge, ArtPro, Photoshop, Acrobat ...

### The Syncer Tray icon

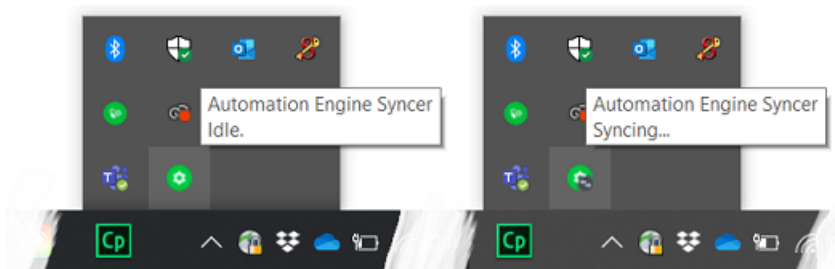

Very similar to the tray icons of OneDrive or Dropbox, you can see what the Syncer is doing when you hover over its tray icon.



**Note:** The Syncer tray icon is invisible until the syncer gets a first synchronization request.



**Note:** The Syncer has no entry in the task bar (Windows) or dock (macOS).

The system tray icon reflects the state of the syncer through different icons:

- **Idle:** All data is synchronized.
- **Syncing...:** Syncer is busy synchronizing data.
- **Waiting:** Syncer is waiting till the user signs in to Automation Engine.
- **Offline:** Syncer is not able to contact the Automation Engine server.

The syncer also pops up an alert dialog when there is a problem. Some ask the user what to do / which file to keep (learn more below).

### The Syncer dialog

Click on the tray icon to open the Syncer dialog. Some examples:

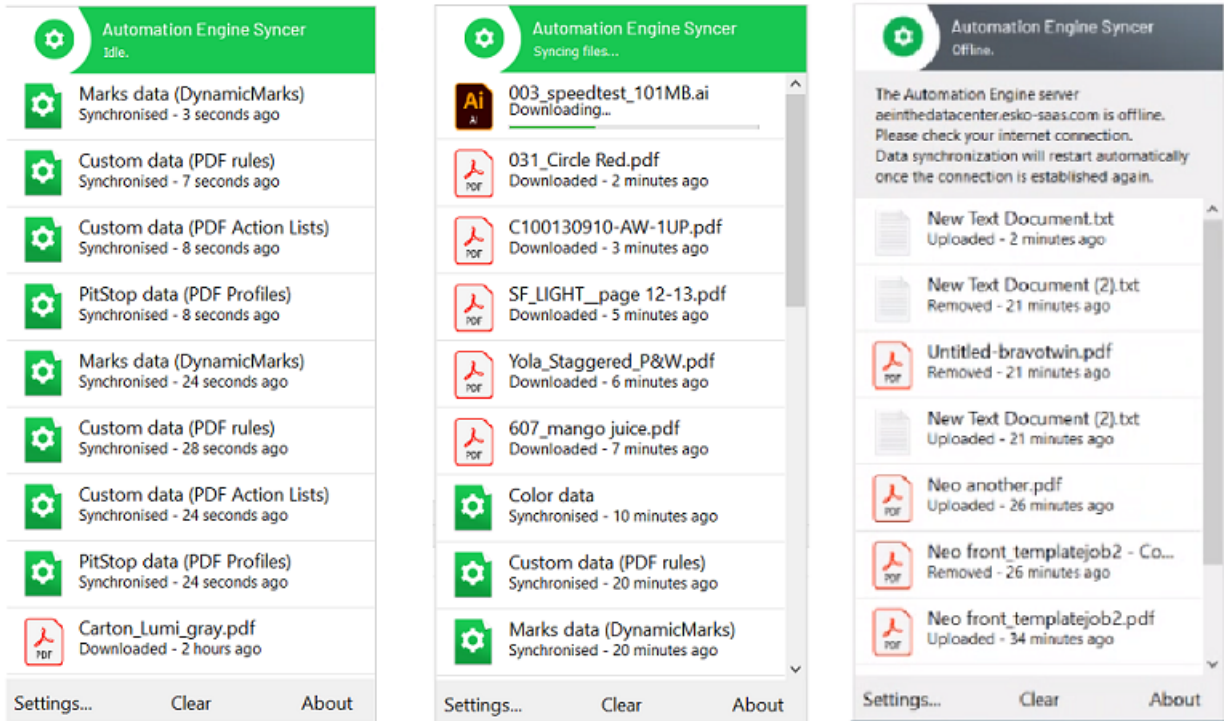

In normal circumstances, there is no need to check this dialog. However, it can serve these purposes:

- to see that something is happening.
- to see that resources are also involved in the current syncing
- to see that there is some problem. However, any issues will also appear as pop-up messages.
- **Settings**

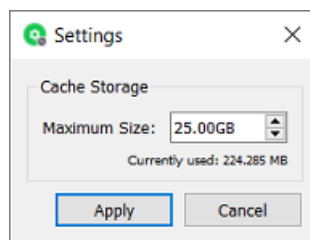

- **Cache Storage**
  - When the user downloads more Container data files than the **Maximum Size** of the cache, the Syncer will automatically remove files that have not been used for a while (i.e. not accessed since 3 days).
  - It does this until the size of the cache data again drops under the here defined Maximum Size.
  - The maximum cache size (default 50 GB) cannot be set lower than 5 GB.

- **Clear:** Click here to manually clear all finished (failed and successful) synchronization messages in this dialog.



**Note:** When this list has grown to 5000 entries, it auto-deletes the oldest 1000 entries.

- **About:** Shows the software version and build number.

### What about other Esko and Non-Esko Editors?

Interactive applications (editors) that are not integrated with the Syncer tool can only be incorporated in this syncing in a limited way or not at all.

- **Basic Syncing is possible with non-Esko editors:**

When the data that such an application opens is inside an AE SaaS Container (in the data center), then that file will also be synchronized to the local cache folder. For example: Photoshop opening a PSD file, Acrobat opening a PDF file.

- **Esko Classic Editors AP/PE/PL/i-cut are not supported in a SaaS setup:**

With Esko classic editors, we mean (all versions of) ArtPro, PackEdge, Plato / i-cut, FastImpose.

Typical of Esko's graphical editors is that they work with central resources (color book data, fonts, marks...) and also that they operate on files that can contain links to other files (aka 'external files', such as images, one-ups, CAD files...).

This smart working with external data is crucial for them to work.

However, the Esko classic editors were not and will not be updated to be aware of the Syncer tool.

**That is why these editors are not supported in an AE SaaS setup.**



**Important:** As a consequence, resources that are only editable by these classic editors (SmartMarks & CAD style data) are also not supported in an AE SaaS setup.

### Conflicts

When the Syncer detects a conflict, he will ask you what should be done:

- A file is updated in the local cache but it was also modified in the data center after its last sync operation.
- A file is updated in the local cache but it got removed in the data center after its last sync operation.
- A file gets removed from the local cache but it was modified in the data center after its last sync operation.

In these rare situations, a detailed dialog appears mentioning this conflict.

- When a file has updated both in the local cache and in the data center, a dialog appears where the user can choose to keep the local cache file or the data center file or both.
  - When the user chooses to keep the local cache version, this version is uploaded to the data center.
  - When the user chooses to keep the data center version, the data center version is downloaded into the local cache/
  - When the user chooses to keep both:
    - the file in the data center gets renamed by adding a suffix to the file and this file gets downloaded to the local cache/
    - the updated file in the local cache gets uploaded to the data center/
- When a file is updated in the local cache but it was removed in the data center after its last synchronization operation, a dialog appears where the user can choose to:

- OR upload the updated file from the local cache to the data center
- OR remove the file in the local cache
- When a file is removed from the local cache while it was modified in the data center after it's last synchronization operation, a dialog appears where the use can choose to:
  - OR remove the file in the data center
  - OR download the updated file from the data center to the local cache

### FAQs

- **Q: What with linked files / placed art?**
  - A: When a file is opened in ArtPro+, then ArtPro+ checks if the embedded data is still in sync with the placed art. When that file is opened from the a SaaS data center, it will be avoided when there is no need to download that placed art (again).
- **Q: What if 2 users both open, change and save a same file?**
  - A: The last one that saves overwrites the previous version. No message will pop-up. There is no locking technology in place.
- **Q: What if 2 users work on the same file and their saving crosses the syncing?**
  - A: If a user works on a file in AP+ saves the file AND there is someone else also working on that file and has already saved a newer version on the data center, then there will be a conflict. The syncer dialog will pop up a message and make the user choose an option: replace - cancel - keep both (see details above).
- **Q: Can I open more than 1 file at once?**
  - A: Yes.
- **Q: Can we have only one local cache in our location, in stead of one for each workstation?**
  - A: No.
- **Q: What happens when the network temporarily goes offline?**
  - A: The Syncer reacts actively when there is any change to local machine's network.  
 As soon as the network connection with the Automation Engine server is established again, the Syncer automatically resumes its work. Also when this network problem occurs in the middle of an upload, the Syncer will be aware and, as soon as he can, start that upload again from zero.  
 There is no way (and no need) to start the Syncer again manually.
- **Q: It this tool only available in English?**
  - No. This tools follow the regional settings of the users that is logged into to the local operating system. Supported languages are English, French, Spanish, German, Italian, Japanese, Korean and Chinese (CN and TW).

## 20.8. Local Editing Applications in a SaaS workflow

---

What happens when local editors open and save files is described in the above page about the [The Syncer Tool](#) on page 1670.



## 20.9. Migrating from an On-Premises AE to a SaaS setup

---

### A gradual process

There are fundamental differences between Automation Engine SaaS and its on-premises counterpart. Not everything can be migrated as-is, this due to practical, technical and security reasons: some things will have to be configured differently, workflows might have to be adapted.

Before attempting a migration, make sure you have a good understanding of what Automation Engine SaaS is all about. A good starting point for this is the [eLearning Module "AE SaaS Concept and Technology overview"](#). This chapter in this manual then adds some detail.

As mentioned in that eLearning module, Esko offers dedicated personnel and tools to advise and assist you in migrating from a single or multiple on-premises server(s) to a SaaS setup.

Migrating to a SaaS setup is always prepared and executed by specialized Esko staff.

Typically, a migration to SaaS is a gradual process (opposed to switching overnight). Over time, more and more of the production is migrated. For some time the on-premises server and SaaS server will run alongside each other (in a typical migration, the on-premises server is licensed for another year). That will have an impact on how data and configuration is moved.



**Attention:** To migrate an on-premises Automaton Engine to SaaS, the on-premises Automation Engine must be on version 22 or higher.



**Tip:** It is possible to sign in to multiple Automation Engine (master) servers. Administrators may need this functionality in special cases like during this migration of an on-premises server to its SaaS setup. To do this, sign in to the Pilot of server 1, and in the resulting Pilot's File menu, ask a **New Connection**. This will open an extra sign-in dialog where you can sign in to another AE master server.

### As a tool in this migration, restoring a backup is limited

When migrating your on-premises AE server to its SaaS setup, it is possible to restore many parts of the configuration of the on-premises server onto the SaaS server. The **Server Admin > Restore** function on a SaaS server even offers a dedicated extra option: **Migration Configuration (From on-premises to SaaS)**.

This restore mode will restore all the configuration items that do not conflict with the base configuration that was already set up in the data center by dedicated Esko staff.

This partial restore will also be executed by specialized Esko staff.

And not only the configuration can not be simply copied over. To cope with some limitations of a SaaS setup there will probably also be a need to check and change some of the workflow tickets. For example to remove absolute URLs pointing to the old server, reconfiguring devices over an Agent, ...).

### What about migrating my files?

As mentioned earlier, storage on Esko Cloud is cheaper and more scalable than regular storage on AE SaaS containers. Therefore AE SaaS customers should store Jobs and Products that are not actively used on Esko Cloud (as [Inactive Jobs](#) and [Products on Esko Cloud](#)).

Migrating Jobs and Products to AE SaaS means moving them to Esko Cloud.

This has the added benefit that both the AE SaaS and the on-premises server can work with the same Jobs and Products database. This avoids the need to sync during a gradual migration.

Also here, Esko specialized staff will assist you.

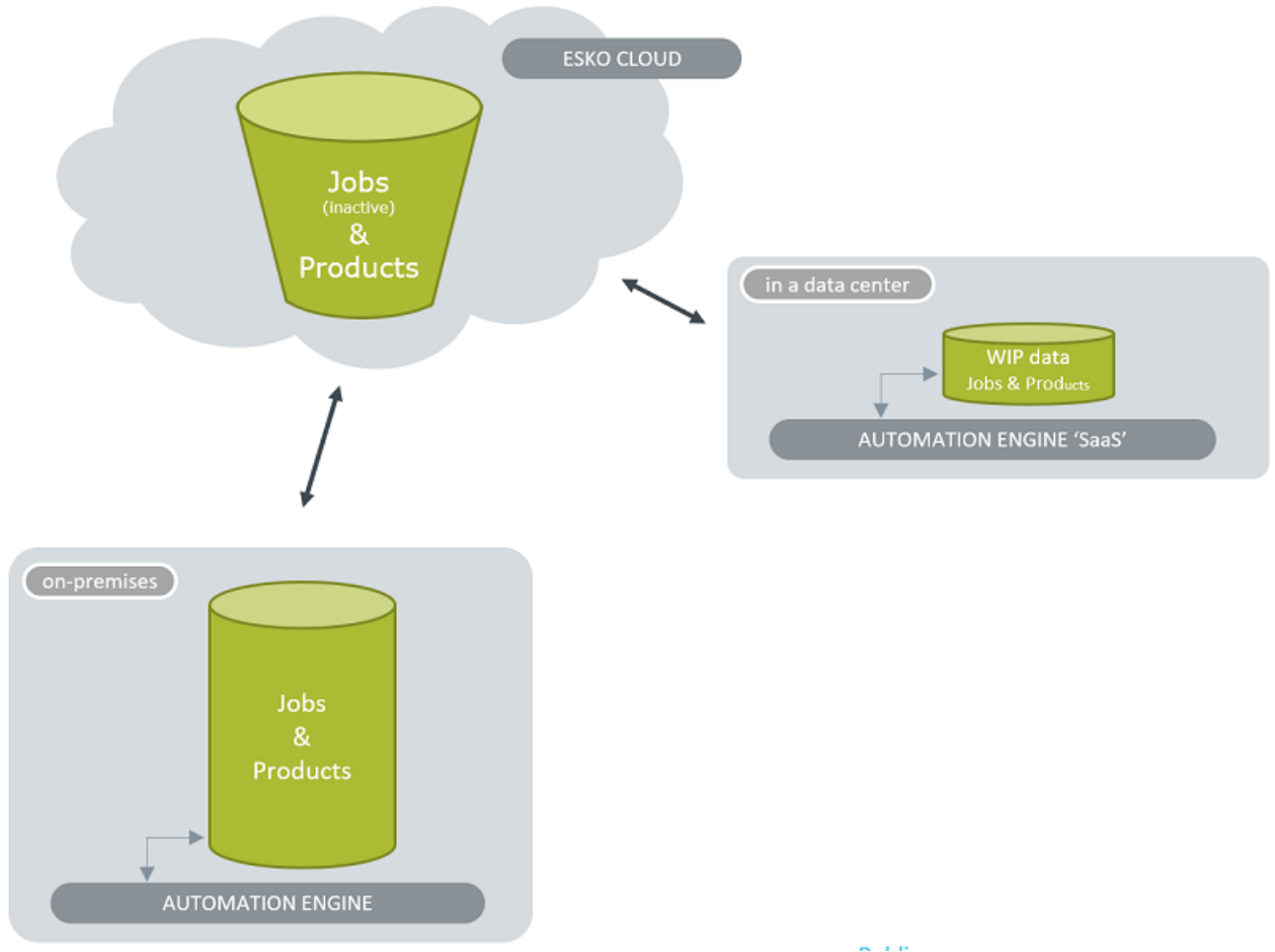

## 20.10. Filtering on Locations after consolidating all data

### Concept

We'll use these illustrations to explain the concept of 'Locations':

1. A company with many locations plans to migrate its on-premises setups of Automation Engine to a SaaS setup.

**A multi-location company wants to consolidate its prepress production**

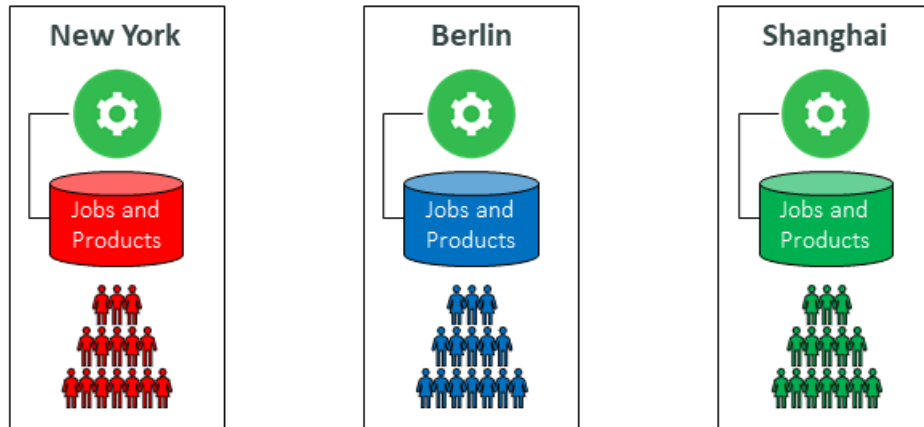

- 2. Each location moves its data to the SaaS setup, most probably to the Esko Cloud storage.

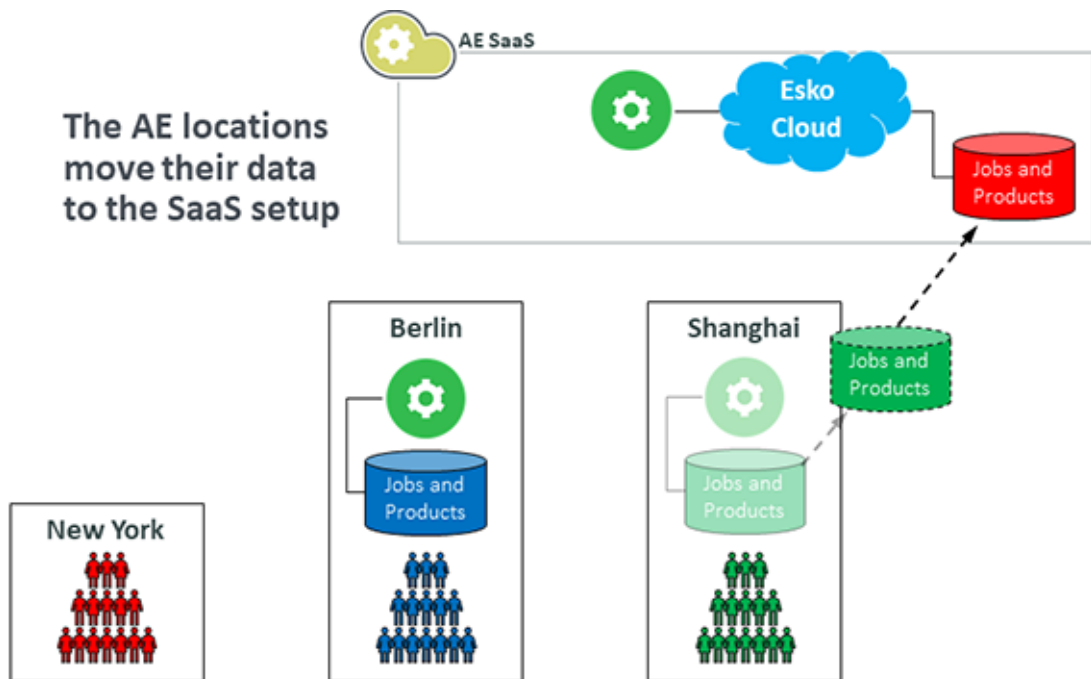

- 3. All data that currently is used or relevant is kept in the data center, the bulk of prepress data can stay on Esko Cloud.

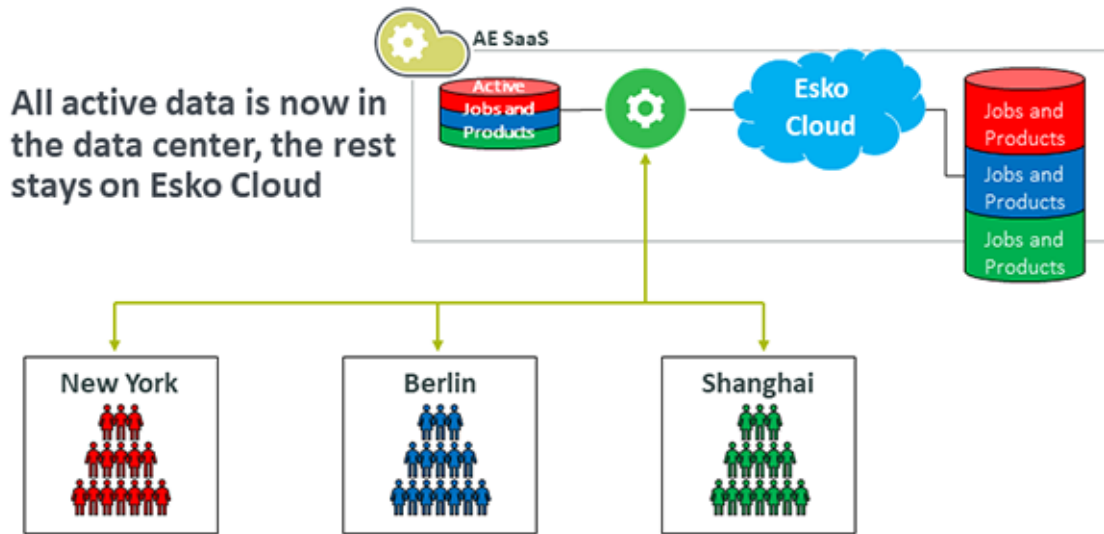

4. But now all users will see and have access to all jobs of the whole company, while maybe they still only need focus on their 'regional' jobs.

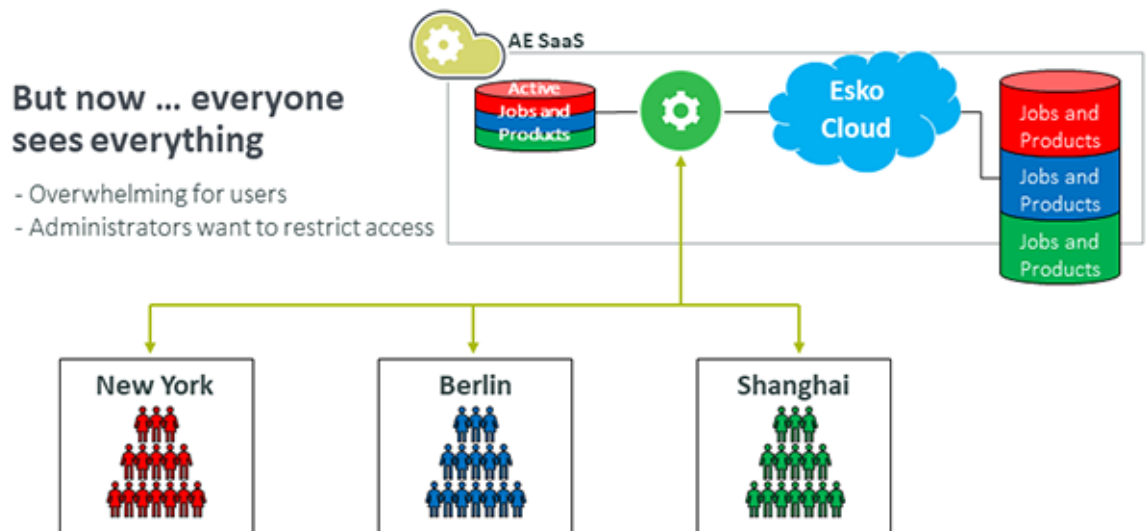

5. Administrators can introduce the use of Locations: Its first main objective is to function as a filter on the data the (regional) users can see.

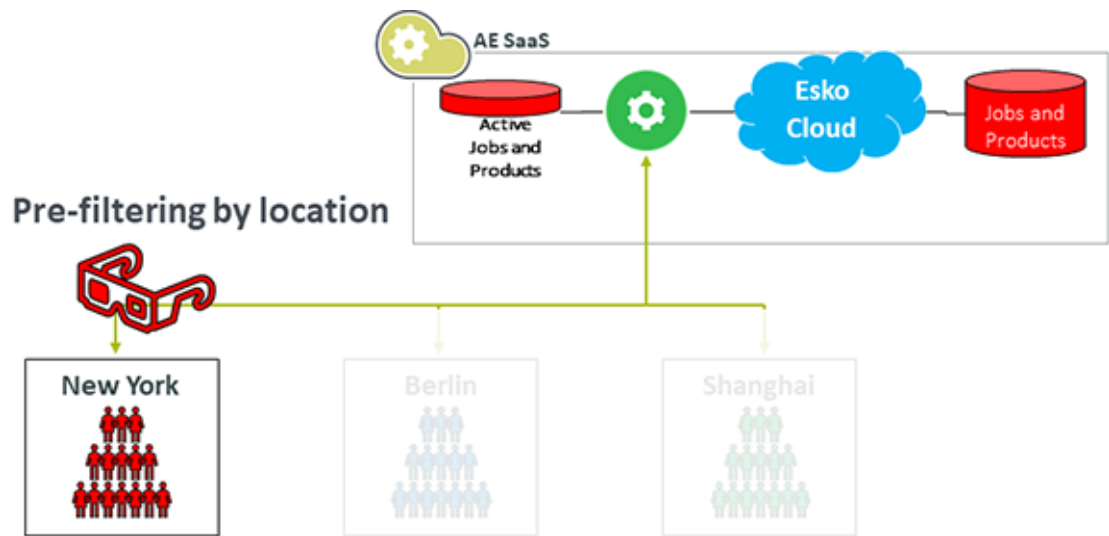

### Using 'Locations'

- First set a location as an attribute of a Job or Product (when creating new ones or by setting a location for existing ones).
- Then define, per user group, which location(s) these users are restricted to.

A user will notice this in these places (in My Workspace):

- Only Jobs and Products of that location are shown (and all those that do not have a location attribute yet).
- The Activity and the To Do list only show items of these Jobs / Products.

## 20.11. Integrating with (multiple) MIS



**Note:** Learn the basics about integrating Automation Engine with an external system like an MIS or ERP in the dedicated chapter [Integrating with External Systems](#) on page 1769.

### Integrating with one MIS

When the AE SaaS only gets commands from one MIS, the workflow is as described earlier: A local Agent will handle all JDF/JMF communication between the 'local' MIS and the AE SaaS.

Learn more in [The Agent](#) on page 1637.

### Integrating with more than one MIS via JDF/JMF

When multiple MIS want to create Jobs, Products or Customers on AE SaaS, you risk conflicting names ; these names have to be unique on AE.

When these MIS do that via JDF/JMF, the JDF processor in Automation Engine also has to stick to that standard language. This is important when it comes to sending feedback from AE SaaS back to the MIS: it still needs to be standard JDF/JMF and it of course needs to be to the right MIS.

Below illustrations show how, in JDF/JMF integrations with more than one MIS, we need to avoid these clashing names of Jobs, Products or Customers.

**Problem:**

1. A multi-location company that uses more than one MIS wants to consolidate its prepress production:

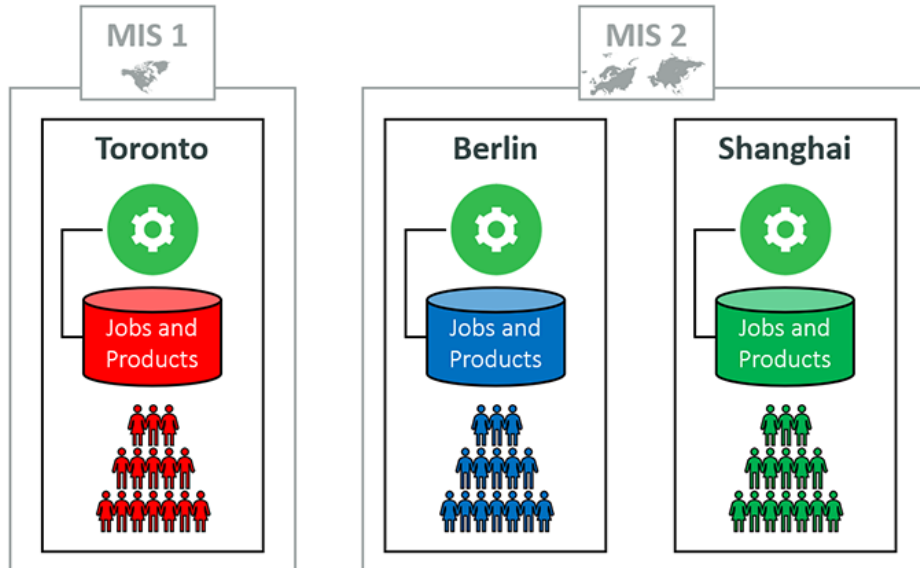

2. When moving to 1 same AE (AE SaaS), and still work with those 2 MIS, there is the risk of clashing Job, Product or Customer names:

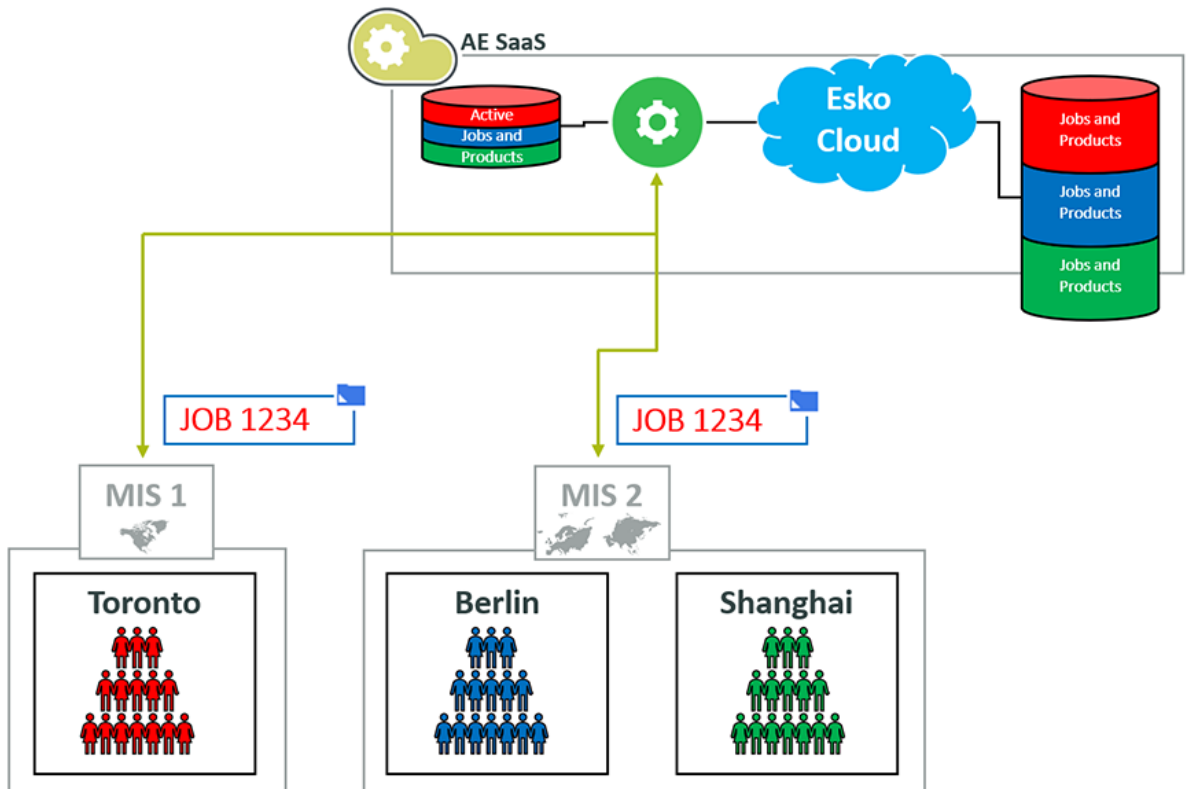



**Note:** This workflow typically also uses the 'Locations'. Learn more in [Filtering on Locations after consolidating all data](#) on page 1676.

### 20.11.1. Working with Agent Prefixes in JDF/JMF integrations

#### Concept

Below illustration shows how, in JDF/JMF integrations, adding prefixes to the names of Jobs, Products and Customers avoid clashing of these names on Automation Engine.

This happens automatically once an administrator of the Agent configured such an Agent Prefix, a special tool that solves working with multiple MIS and still offers bi-directional communication while sticking to the standard formatting of JDF/JMF.



**Attention:** This tool is not supported in these environments:

- When multiple MIS's connect to an on-premises AE server.
- When multiple MIS's directly connect over HTTPS to an AE SaaS server.
- When MIS integration is not done via JDF/JMF (via an Agent), but for example via XML files.  
Note: There are many XML editing tools in Automation Engine that an administrator can use to make a custom solution.

#### Solution:

In below example illustration, we see local Agents prefixing the name of Jobs with `NAM_` when they come from the MIS used in North America and with `EURAS_` when they come from the MIS used by the European and Asian users.

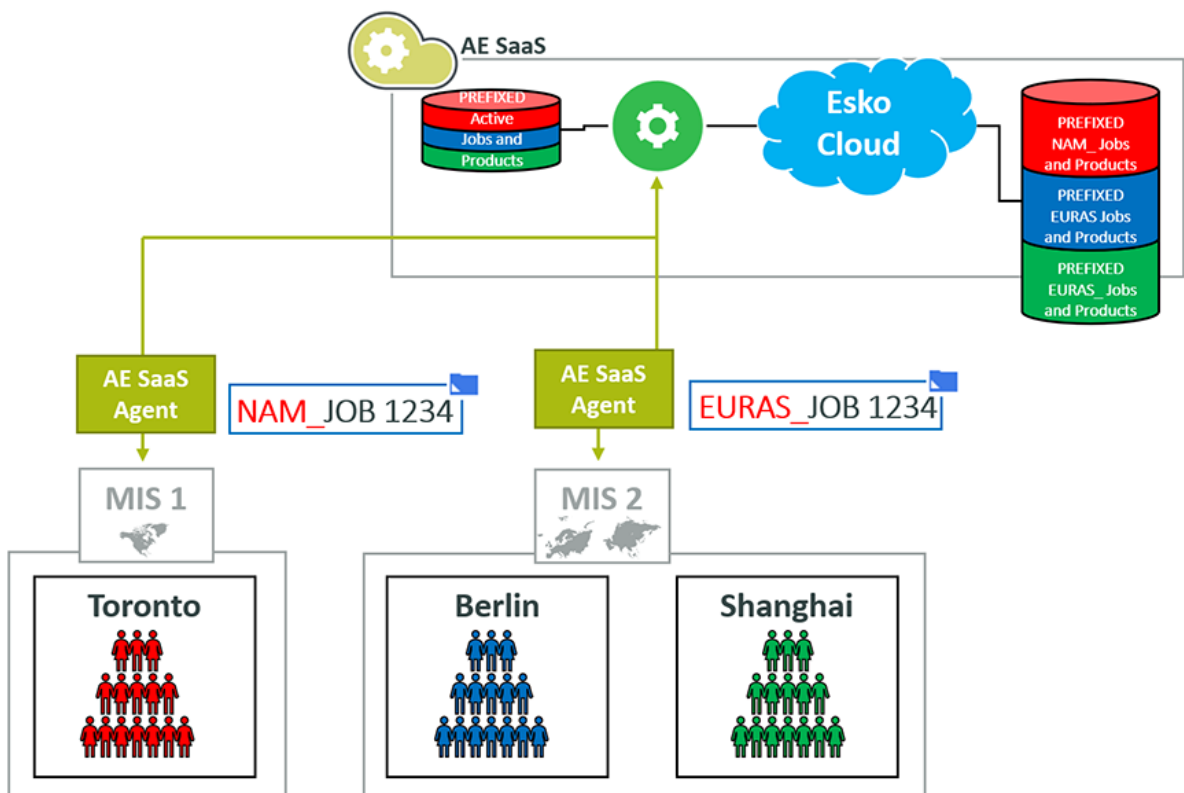

This solution also requires **Un-Prefixing**:

When Automation Engine SaaS then sends feedback to the MIS (JDF/JMF), it un-prefixes the related fields again: This way the MIS will recognize the exact name that it initially sent to the Agent (Automation Engine). The MIS application or its vendor does not have to do anything.

**How to set up Agent Prefixes**

1. Sign in to the [AE Agent web pages](#) as an AE administrator.
2. Go to the page **MIS**.
3. The **Agent Prefix** currently used by the Agent is displayed. You can modify the prefix. A prefix can have a maximum of 8 characters (the typical valid Windows file name characters).



**Note:** The amount of characters you use here as a prefix will reduce the maximum length of the name of the Job/Product/Customer.

4. When clicking **Apply**, the modified prefix is saved and the Apply button is disabled.

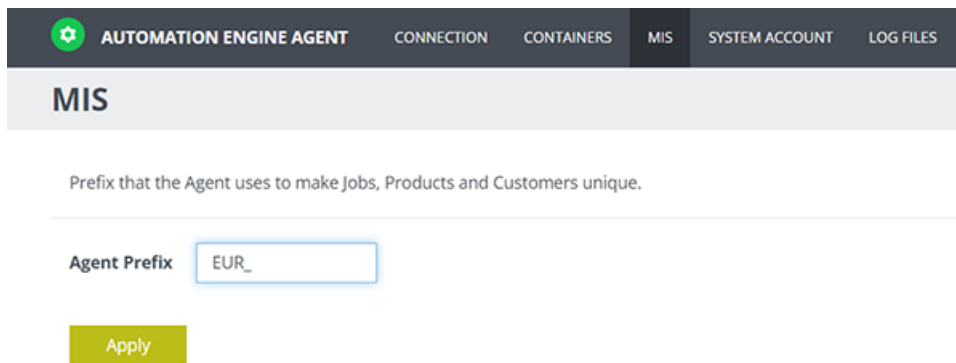

**What happens in background**

- All JMF messages that the MIS sends to the AE SaaS now use the Agent Prefix for that MIS.
- All JMF messages that AE SaaS sends back to the MIS are un-prefixed, i.e. the Agent Prefix is removed. An Agent also ignores messages that have another prefix or that have no prefix.
- These JMF/JDF attributes are (un-)prefixed by the Agent:
  - **JobID**
    - When prefixing a JDF for Job creation, a [general Job Parameter](#) 'MIS\_PREFIX' is added to the Job's setup (so also becoming available as a SmartName).

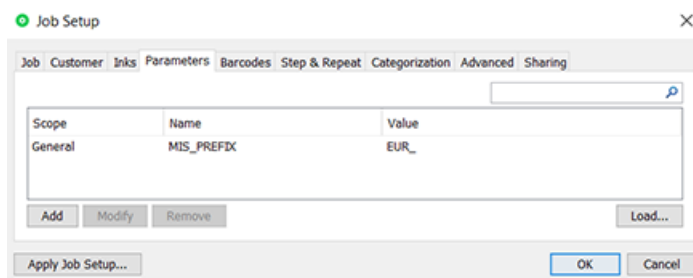



- When un-prefixing, this job parameter is removed from the message (so to not confuse the MIS with this extra parameter).
- CustomerInfo/**CustomerID**
- Company/**OrganizationName** (used as CustomerName)
- PageList/PageData/**ProductID**
- PageList/**ProductID**: Just like with Jobs:
  - When prefixing, a Product Parameter is added to Product's setup (so also becoming available as a SmartName).
  - When un-prefixing, this product parameter is removed from the list.

## 20.11.2. Task 'Prefix Products on Esko Cloud'



**Note:** Learn about the concept of adding prefixes in [Integrating with \(multiple\) MIS](#) on page 1679.

In such a setup where multiple MIS are connected to a same Automation Engine on-premises, to be able to migrate to a SaaS setup, the names of the Product should first be made unique.

This task serves to prepare that migration.



**Note:** After the migration to AE SaaS, all new products can get a prefix in their name from the beginning. Learn more in [Working with Agent Prefixes in JDF/JMF integrations](#) on page 1681.

### Task settings

- **Prefix products that match the following criteria:** Define a filter to list the products on Esko Cloud of which the name and ID should be prefix-ed.
- Define the **Prefix**:
  - It may not be longer than 8 characters.
  - It may not contain invalid Windows file-name characters.



**Note:** The task will not add the prefix when it detects that the product already has that same prefix.



**Note:** This task can be started on an empty token, i.e. it can be started without any input files.



**Note:** Any SmartNames in this task will calculate their value based on the first input file (found with that filter).

### Task result

- The prefix is applied to:
  - the **Name** of the product

- the **Product ID** of the product
- the **Name** of each product part.
- A product parameter is automatically added with as name `MIS_PREFIX` and as value the chosen prefix. This allows AE workflows to react to this presence, for example to remove that prefix on a proof or report.

# 21. Sharing to Collaborate with other AE servers

---

## 21.1. Concept and Terminology

---

### 21.1.1. What is Esko Cloud?

**Esko Cloud** is the name of an Esko web architecture. It is used as basis for several Esko solutions with both internal and external partners.

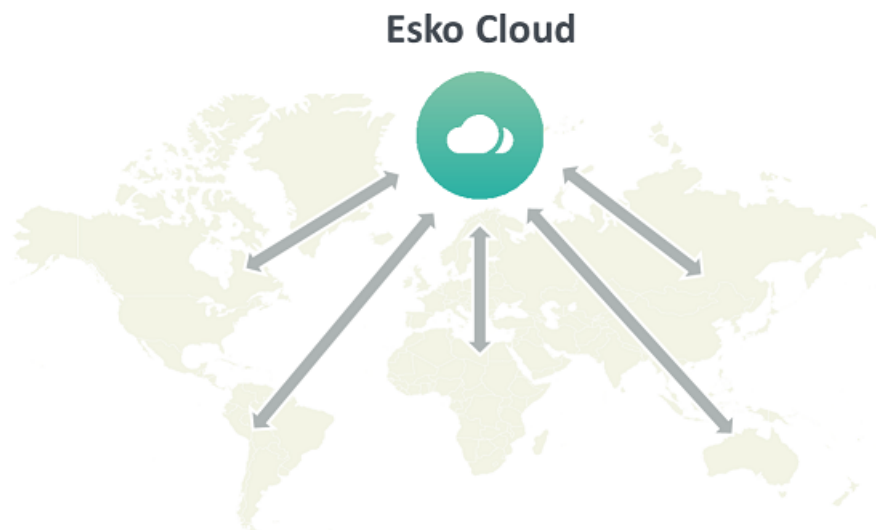

- When the main goal is to share and approve data over the web, the Esko product is named "**Share & Approve**". This product does not require Automation Engine. Therefore it is not described in this manual. Find its dedicated documentation on <https://www.esko.com/en/Support/Product?id=Share%20and%20Approve>.

This chapter does describe the setup and tools in Automation Engine to connect to Share & Approve.

- Esko Cloud can also be used to exchange Jobs between Automation Engine servers in different locations. This collaboration between AE servers is enabled by dedicated tasks and tools within Automation Engine.

This workflow is described in the separate chapter [Sharing to Collaborate with other AE servers](#) on page 1685.

- AE SaaS customers can also use Esko Cloud for data storage. AE SaaS Containers are located in the data center and this type of storage can become expensive and hard to scale up. AE SaaS

customers with an Esko Cloud account can choose to move finished Jobs or 'sleeping' Products to Esko Cloud as a near-line storage, a more affordable and easily scalable solution.

This workflow is described in the separate chapter [AE SaaS: When your AE is in a Data Center](#) on page 1633.

### 21.1.2. Concept of Collaborating Automation Engines

The main reasons to have Automation Engine's from different locations collaborate are:

- Spreading work-load over multiple sites.
- Offloading work to a location where cost of staff is lower.
- Offloading work to locations where staff has more specialized skills.
- Executing exceptional tasks (rare processing) in the site that has that software license.

The way these Automation Engine (Master) servers can collaborate is via [Esko Cloud](#), an Esko web architecture.

In this concept, the focus is on exchanging Jobs and their data, i.e. these 2 use cases:

- As an AE user, I want to make a job available to other sites for collaboration.
- As an AE user, I want to see a list of the jobs on Esko Cloud so I can collaborate on a certain job from another site.

Automation Engine users can also share (workflow) tickets to Esko Cloud.

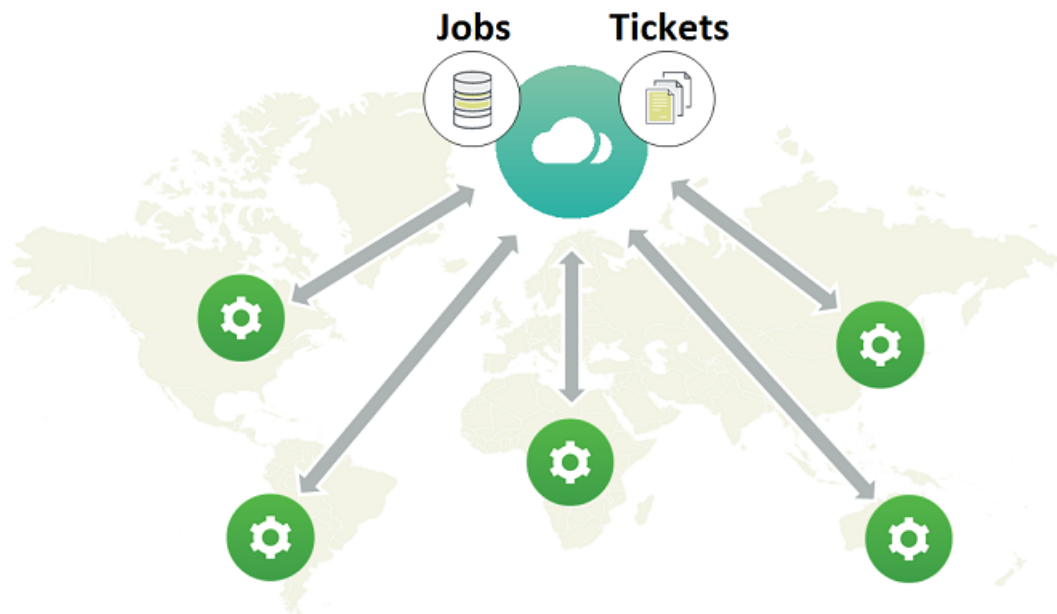

**Important:** This is not restricted to AE servers installed on-premises ; Also an [AE SaaS](#) server can be included in this sharing.



**Important:** Esko Cloud stores all data **per customer**. This is why standardization of customer IDs or names between all these locations is crucial. Learn more in [FAQs and Tips on Customer Consolidation](#) on page 1722.



**Note:** The licenses that enable these tools are offered under the module named 'Automation Engine Cloud Connector' (in its early stages, some called this setup 'Automation Engine Enterprise').

### 21.1.3. What is a Group? What is a Location?

In the context of collaborating Automation Engine servers,

- a **Location** is the place where an Automation Engine master server is located.

The name of a location is not the name of the AE server.

The name of a location is the one given in Esko Cloud for its connection to that specific AE server. This is also known as the **Esko Cloud Connection**.



**Important:** This is not restricted to AE servers installed on-premises ; Also an [AE SaaS](#) server can be included in this sharing.



**Note:** In this chapter, the term 'Location' does NOT refer to the attribute in a Job or Product setup (a type of filter which is mostly used in a SaaS setup and described [here](#)).

Files or applications that are stored in a location or often referred as 'local' files or applications.

- The **Group** is the company that owns several of these locations and that wants to set up this collaboration. Typically it is this group that sets up its own (web)site in Esko Cloud.



**Note:** It is however possible that a groups sets up more than one site in Esko Cloud. For example to separate all files related to beauty products from those that are pharmaceutical (and the involved staff).

Throughout this chapter, we use the example of the group "SuperPrint" that has 4 locations that use an Automation Engine:

- MEX001, in Mexico City, MX
- BER001, in Berlin, DE
- SYD001, in Sydney, AUS
- TOK001, in Tokyo, JP.

### 21.1.4. What is Uploading? What is Sharing?

#### Uploading and Downloading Files

An Automation Engine user can, in the job folder of an active job, make a selection of files and or folders and [Upload these to Esko Cloud](#). This copies that data to the group's site in Esko Cloud, more specific in the data zone of the customer of that job.



**Note:** It is not foreseen to upload all data from a Job. You need to make a selection.



**Note:** FAQ: Why is this only supported on files that are inside an active (blue) job? Because, conceptually, when you initiate collaboration on data with other location(s), this means that this job is 'busy'.



**Note:** You can also upload job data to Esko Cloud for archiving reasons. Once it is in the cloud, you can delete it from the Automation Engine Container.



**Attention:** The job will be created automatically on Esko Cloud when it doesn't exist there yet, but this is not the case for the job's customer. Before any uploading, you **first** need to establish links between local and cloud customers. We also call this the *customer consolidation*.

An Automation Engine user can, while being in a an active job, go to the view "**Esko Cloud**" and see which files were uploaded to Esko Cloud. The user makes a selection and chooses to [Download to Job Folder](#). This copies the data to the selected job folder and, if needed, creates the same structure of subfolders as on Esko Cloud. This also overwrites any same file in the same place.

### Sharing and Unsharing Jobs

When you share a job, you create that job on Esko Cloud. This is not just a folder but also includes all its meta-data (the 'Job Setup').

Sharing a job itself does not move or copy any files.

You can also specify which other location(s) you want to share that Esko Cloud job with. You thereby invite these locations to collaborate on that job. They will then also see that job and its files on Esko Cloud.

You can only share jobs with other locations when their local customer was linked to a cloud customer.

You can't share files, only jobs.

The location that shared the job is shown in columns and lists ; it is referred to as "Shared from". Only this location can unshare it.

Unsharing a job removes the job and its files from Esko Cloud.

### Can you Upload Files of a Job that is Not Shared yet with another location?

Sure you can. But no other location than yours will be able to see that job and those files until you share it with that other location.

When the job of those files does not exist yet on Esko Cloud, it will be created automatically.



**Note:** As mentioned above, the customer of this local job needs to be linked first with its counterpart on Esko Cloud.

## 21.2. The Importance of Standardization between Locations

### Standardization between Locations on Customer Names/IDs

In Esko Cloud, data is stored per customer.

It is crucial to avoid placing data of one customer in a folder of another customer. Therefore, it is important that every local AE customer is linked to the correct customer in Esko Cloud. We often refer to those as 'local customer' and 'cloud customer'.



**Note:** Esko Cloud is also able to share this data with your end customer, for example via the tools in the product "**Share & Approve**". Obviously, it is then even more important to keep data separate per customer.

That is why it is crucial that all your locations use the same name for a same customer (ID).



**Note:** An example:

- On (one of) your Automation Engine servers, there is a local customer named `Cola`. On Esko Cloud, there are 2 cloud customers with more elaborate names like `Best Cola` and `Super Cola`.
- It is crucial that the local customer `Cola` is linked to the correct cloud customer, so to prevent `Super Cola` users seeing data from `Best Cola` and vice versa.

Managing this list of customers needs to happen on your company group level.

### Standardization between Locations on Folder Structure

It is also important that the different locations standardize on the structure of their Job folders in Automation Engine.

The tool **Smart Job Location** and standardization on where tickets write their output files can help to achieve that.

### Why is Customer-Linking so Important?

Linking the customers from each local customer to the right customer on Esko Cloud will mostly have to be done manually, by a user. Esko software is reluctant to link local customers automatically to cloud customers.

To share a job for the purpose of collaborating with another location, the job must be assigned to a customer and that customer must be linked to a counterpart in the cloud.

Only when the above is fulfilled, you can start uploading files into such a job or downloading files from folders in Esko Cloud.

The correct linking of customers of course is required to **assure** that data from one customer does not end up in the Esko Cloud folder of another customer.

When all up- or downloading of files happens in the Job context of the correctly linked customer, then the risk of making mistakes is drastically reduced.

## 21.3. Setup and initial Configuration

---

### 21.3.1. Required Esko Products

#### Required Esko Products

- A license and an administrator user to set up an Esko Cloud site for your group.
- 1 or more Automation Engine master servers, each connected to the internet.

To start collaboration, you need 2 or more Automation Engine master servers with the same version, each in a different LAN, probably in a different location.



**Restriction:** Do not share data to an AE on a lower version. A lower version AE will not understand the new format of data that is being shared to him by an AE on a higher version.

### 21.3.2. Initial Configuration

#### Step 1 - Create your Site on Esko Cloud

First thing to do is to create your group's ('Share & Approve') **site** on Esko Cloud.



**Note:** In most cases, an Esko support engineer will assist in setting this up. The main steps are described below. Learn more details in the documentation of the product '[Share & Approve](#)'.



**Note:** Each site on Esko Cloud is backed up by servers running [Amazon Web Services](#).



**Note:** In fact, several Esko Cloud web sites are made available and the choice of which one to use, might depend on your group's geographical position. For example: <https://approve.eu.demo.cloudi.city> for organizations with most locations in Europe, <https://approve.as.demo.cloudi.city> for organizations with most locations in Asia.

Follow these steps:

1. In a standard web browser, use the administrative account of your group to sign in to Esko Cloud. That is where you can create and configure 'your' site in the interface of 'Share & Approve'.

As mentioned before, in this context of Automation Engine, we only use the interface of Share & Approve to set up job collaboration between different locations. This means that you need to take care of the next topics:

2. Allow this site to connect with the Automation Engine servers in your group/company. Go to **Setup** > **Automation Engine** and check the box to allow connectivity:



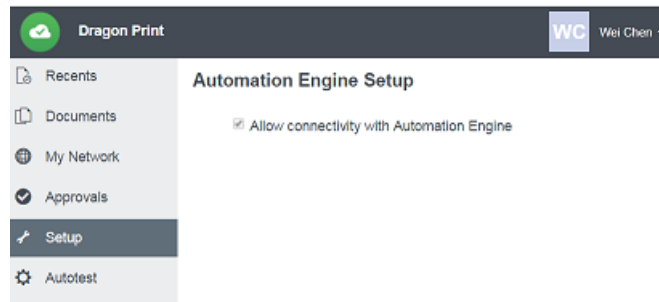

3. Provide sufficient permissions to the group of Automation Engines for them to access the Share & Approve site.
  - a. Go to **Documents**, click to make sure you are in the root folder (top left). Then click (**Share this space**) and choose **Manage Permissions** (top right):

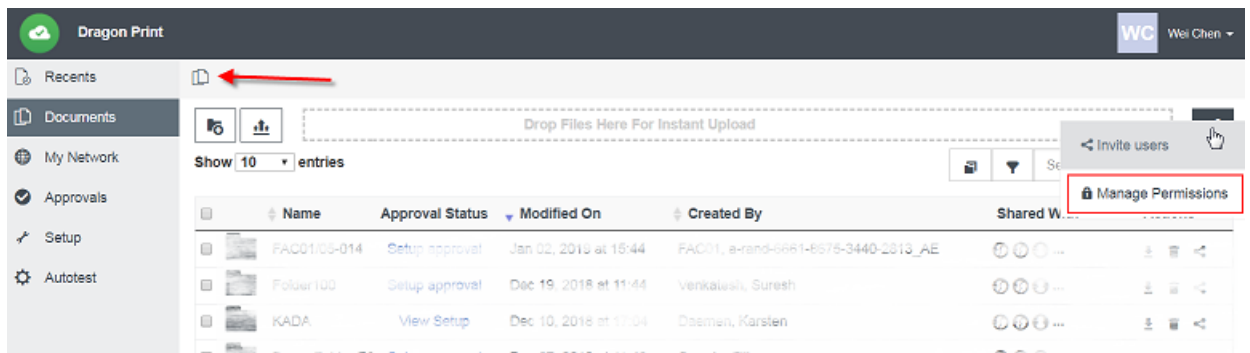

- b. Make sure the group of **Automation Engines** is invited and that this group has the right permissions:

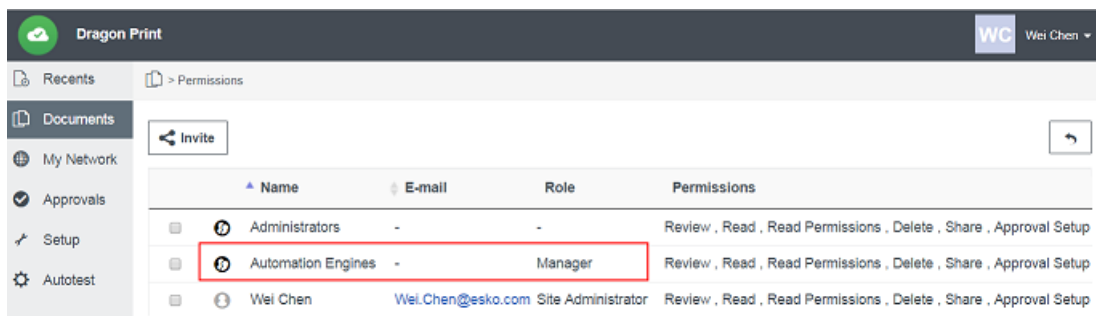

**Note:** This group is the group of AE software servers, not their AE user accounts.

## Step 2 - Create an Equipment entry for each Location

### Concept - Summary

In the Share & Approve site that you created in previous step, you now need to create an **Equipment** for each location.



**Note:** On Esko Cloud, 'Equipment' can represent various things. In our context, they are not (output) devices but software servers.

To gain access to Esko Cloud in an automated way, a **token** is needed to identify yourself. The bearer of the token receives access. Once identified through that token, you get the permissions of the user or machine or ... that corresponds to the supplied token.

Learn below how to safely transfer that token to the Configuration panel of Automation Engine.

### Adding Equipment

1. Go to **My Network > Equipment'** and click **Add Equipment**.

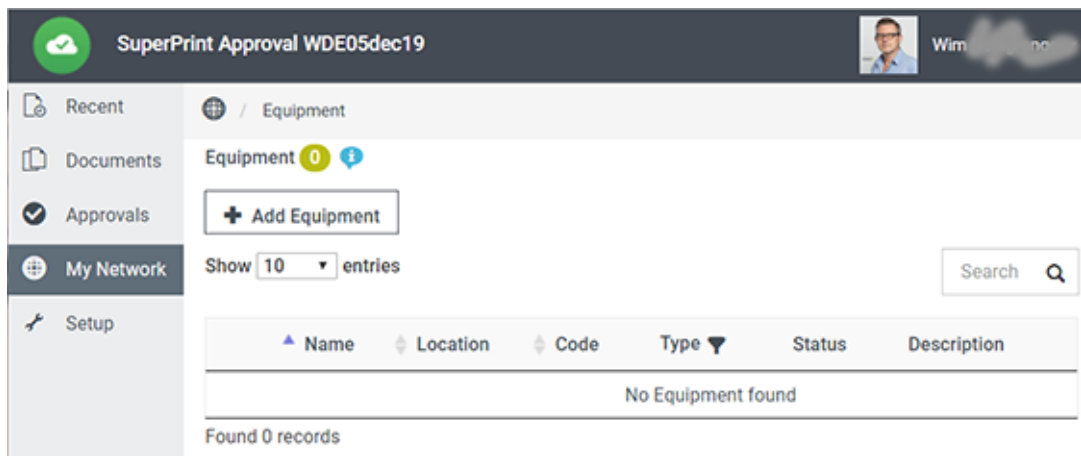

2. In our context (AE servers using Esko Cloud to collaborate), only the fields **Equipment Type** and **Equipment Name** are mandatory.

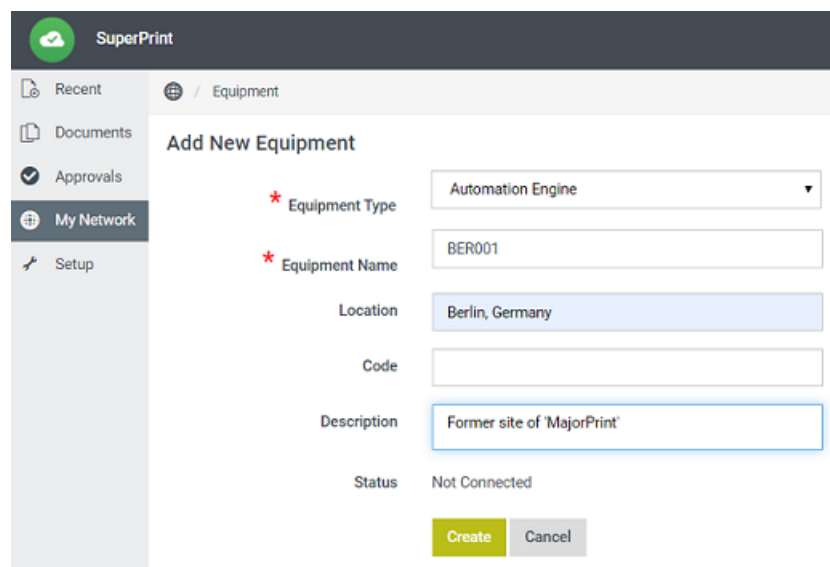

- **Equipment Type:** Select 'Automation Engine' from the list.

- **Equipment Name:** This is the name of the location of this AE server that all users will get to see, including Automation Engine users. To AE users, it will appear as 'Esko Cloud Connection'.

Of all these fields, only the name of the equipment is important to the Automation Engine server software.



**Attention:** The name of an equipment is limited to 7 characters! That is because this name is also used as a prefix to make local customer-IDs unique when they are seen from another location.



**Attention:** You can not change this name later. So think wisely before deciding them. Changing this name would mean removing the equipment first and starting again with a new name, new token, etc. This is an unsupported workflow change.

We strongly advise to **not** use the name of the computer on which the master Automation Engine is running. A name like `AeServer01` or `vm-production-0012` is quite meaningless to AE users in other locations.

Instead, we advise to use a name that refers to the location of that AE server, in a way like [IATA codes](#) are used for airports. For example: Using 'BRU' for the equipment in Brussels, or BRU01 and BRU02 when there would be multiple locations in that same city.



**Note:** These names that are used to identify locations within the organization will pop up at several places in the user interface (Pilot) and will there be referred to as the name of the 'Esko Cloud Connection'. These names should make sense to the users of AE.



**Note:** Also, it is best to keep these names as simple as possible. Avoid special characters in the name like `/`, `space`, `*`, `?`, `#` and similar.

- **Location:** Add a location name that is informational for users of this Esko Cloud site, probably less cryptic than the equipment name.

This field is not shown nor used in Automation Engine!

- **Code:**
- **Description:** You could here mention the actual name of the AE server, or any other info that describes this location.
- **Status:** Indicates if this Esko Cloud site is currently connected to this Automation Engine.

3. Click **Create**. This also creates the token for that equipment:

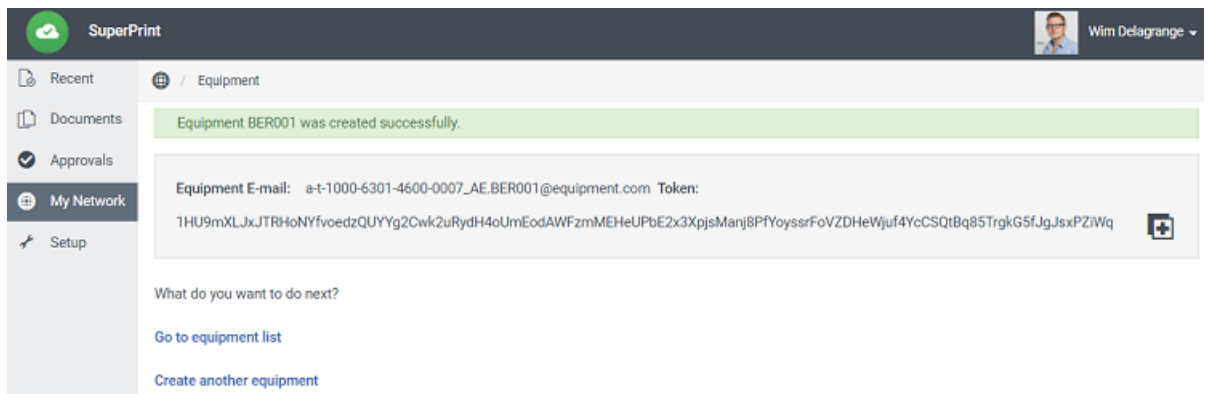

4. Click  to copy the token to your clipboard.



**Attention:** Do **not** manually copy the characters of the token! This will not be enough, The copy-to-clipboard button will copy **more** information than the characters that are shown there.

Keep this copied data in your clipboard until you paste it in AE's Configure tool. See next [Step 3](#).

5. Example of a resulting list of Equipment:

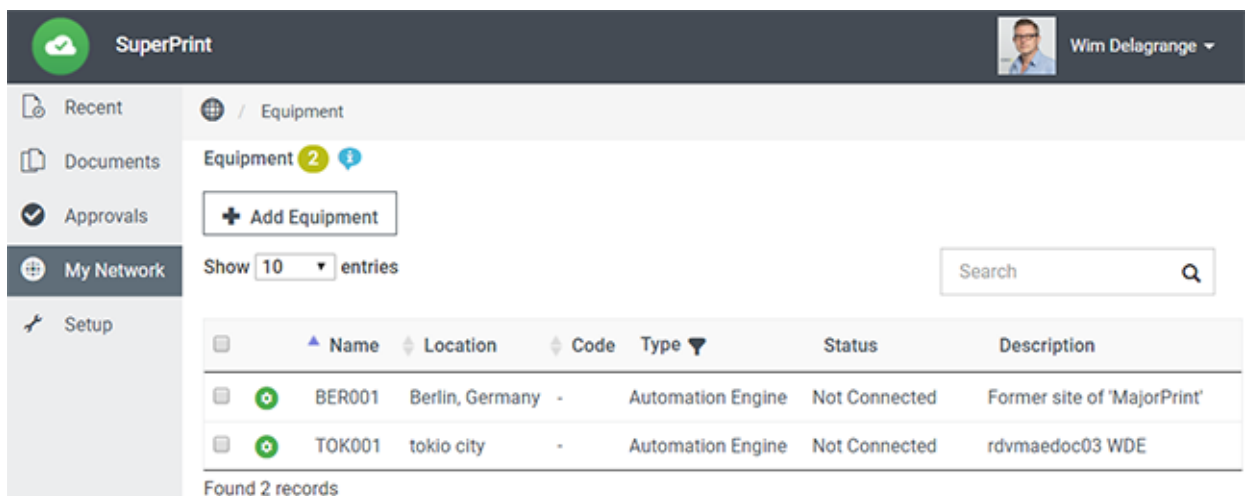

### Step 3 - Bring the Token to AE's Configure tool

#### What does the Token do?

The Automation Engine stores the token and from then on uses it to gain access to Esko Cloud.

So when an Automation Engine tries to connect to Esko Cloud, it presents its token to the Esko Cloud authentication mechanism ([Okta](#)).

The token is checked for validity and whether it corresponds to an equipment of type 'Automation Engine'. The Share & Approve site is set up in such a way that every equipment of this type obtains the necessary permissions for file up- and downloading.

**Conclusion:** When Automation Engine presents its token, it gains access to Esko Cloud and enables all functionality in Automation Engine related to this setup: Job (data) sharing, up- and download of files inside a Job folder, sharing tickets.

### How to Safely transfer the Token to the Automation Engine server and Use it

Safely transfer to the Automation Engine server it was generated for.

1. The responsible (administrator) for Esko Cloud connectivity within your organization, will have a (power) user account that will allow him to log on interactively to Esko Cloud.
2. In that browser, he signs in to Esko Cloud and, in that UI of Share & Approve, navigates to the page where he can create an 'equipment' for a specific AE location. He there generates and 'captures' the corresponding token (using that 'copy' button).
3. The generated token is now automatically copied to his clipboard. Note that it is there in a readable format. This point is where our above description in [Step 2](#) ended.
4. To bring the token securely to the Automation Engine for which it is intended, the *Organization Administrator* can open a remote control application (like 'TeamViewer') and open a session to that Automation Engine server.
5. He then asks the local AE administrator to start a Pilot and there open the **Configure** tool (using his own local account and password). He goes to the item **Esko Cloud** and clicks **Sign In**.

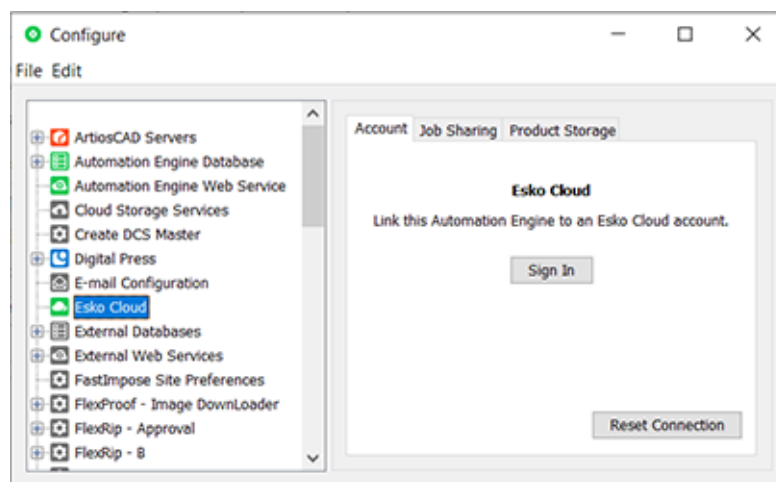

6. Now the Esko Cloud admin user can paste the token from his clipboard directly in the field **Token Details**. This way, he makes sure the token was not exposed in clear text anywhere.

See this example right after the clipboard info was pasted:

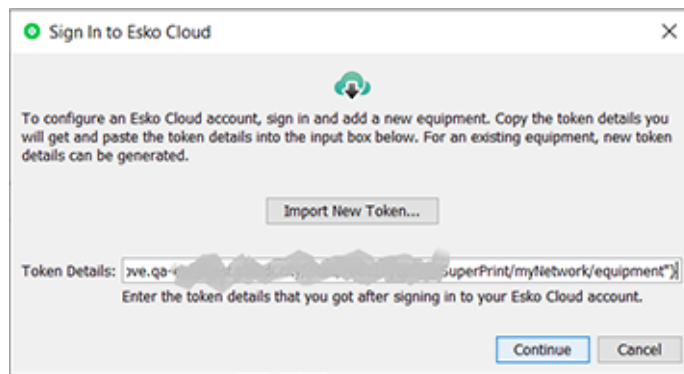

7. Press **Continue** to see the resulting Esko Cloud connection:

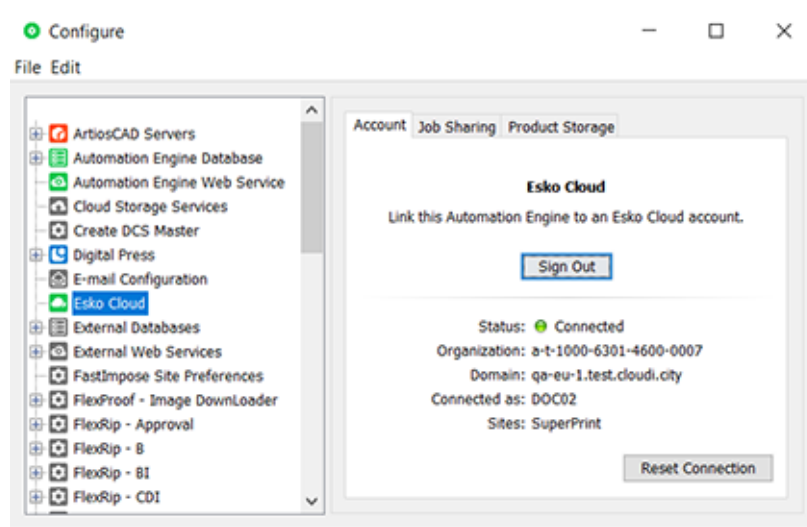

- **Connected as:** This is the name AE users will see as **Esko Cloud Connection** for this AE server.
8. He must then repeat this procedure for each location. As mentioned above, each Automation Engine server requires its own token.

**FAQ: How secure is the token stored?**

Before the token is stored in the internal registry of that Automation Engine server computer ('CFS'), it is encrypted using a 'Certificate' (a private/public key pair).

This certificate is automatically generated at installation time and is stored in the 'Windows Certificate Manager'.

To decrypt the token, you would need that same certificate that was used to encrypt it. Because it is stored in the Windows Certificate Manager, it is pretty secure.

## 21.4. Tools and Tasks

We here describe the tools and tasks that enable AE servers to collaborate via Esko Cloud.

The section [Workflow Examples](#) shows how they can be combined to automate this workflow.

### 21.4.1. On Customers

As mentioned in earlier sections, it is crucial that each local Automation Engine customer is linked to the correct counterpart on Esko Cloud.

Starting to upload files or sharing jobs is simply not possible when the related customers are not correctly linked yet.

In the list of [customers](#) on your Automation Engine (i.e. your 'local customers'), the below described tools become available when you select one or more customers or when you right-click the empty canvas in that list.



**Note:** Deleting a customer locally on or the cloud is always a manual action.



**Note:** When you delete a customer on Esko Cloud, all jobs using this cloud customer will automatically be unshared. And jobs that become unshared are automatically removed on the locations that did not share it.

#### Link to Esko Cloud Customer

Go to the view [Customers](#). This shows all your local customers.

Notice the new column that shows an icon of a chain. When it is shown, it means that this local customer has been linked to a customer on Esko Cloud.

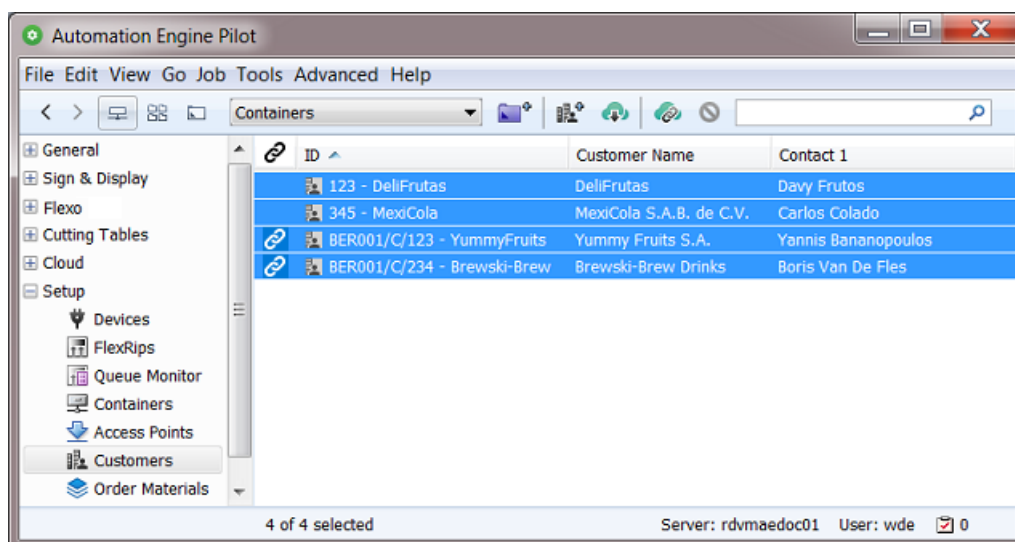

- Select one, multiple or all customers, and click in the top bar (or right-click your selection and choose **Link to Esko Cloud Customer...**).

- A panel appears where you are asked to manually decide with which cloud customer you want to link. The local customer is shown on the left (icon of Automation Engine). On the right, you see the cloud customer that most resembles this local one (icon of Esko Cloud).

Answer the question that is shown at the top.

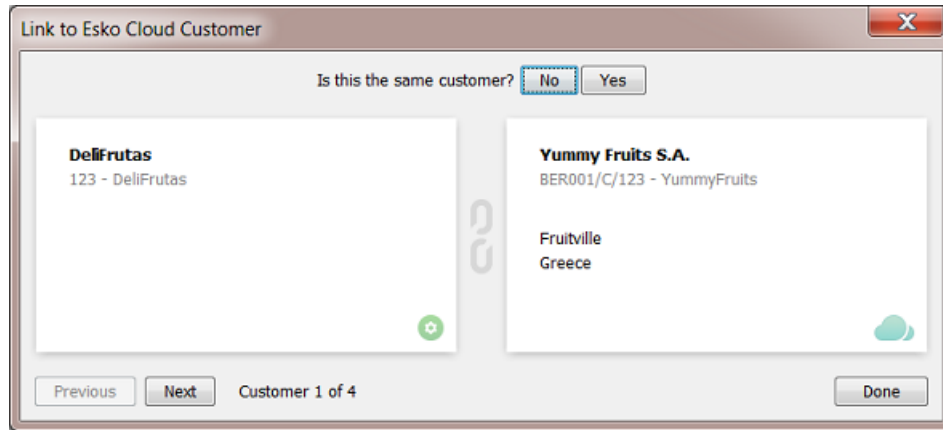

**Note:** In this panel, apart from answering **No** or **Yes**, you can also click **Next** to skip this customer and maybe make this decision later.

- When you answer **No**, another panel opens that shows more cloud customers that resemble this one.



**Note:** Click **Show Criteria** to see which criteria the system used to find similar customers. Change them if that helps you find the one you are looking for.

In our example, the proposed customer `YummyFruit` is not the same company.

When none of the proposed ones matches or when this list is empty, click **Create Esko Cloud Customer**.

- You are then asked to confirm:



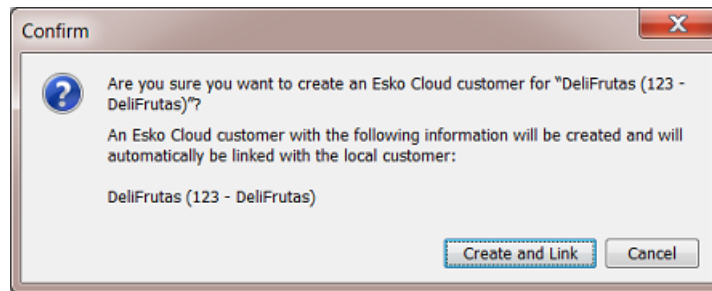

If this is what you want, click **Create and Link**.

- The system then checks the next customer and asks again if the customer on the right matches the local one.

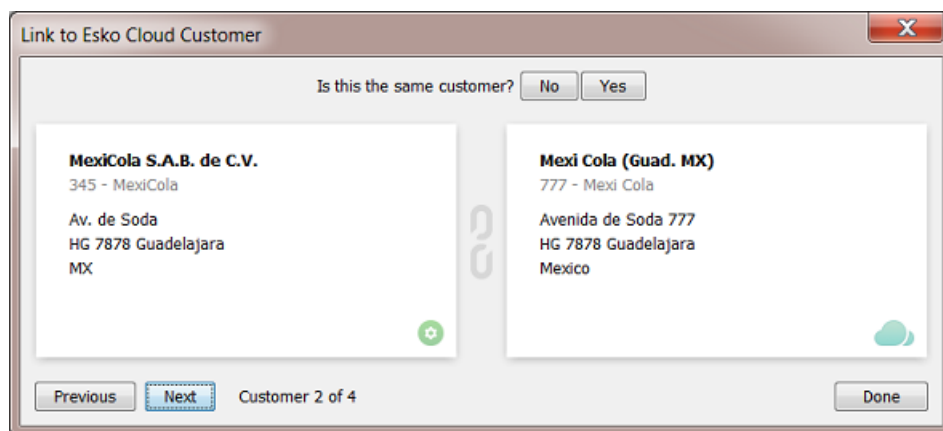

You compare them. In our example we conclude that our local customer is indeed the same as the one in the cloud, so we click **Yes**.



**Attention:** Linking only creates a link. Linking does not change their own settings!

- The system links them and immediately shows us the next one of those we selected. In this case, a chain icon in the middle of the panel informs us that these 2 are already linked to each other:

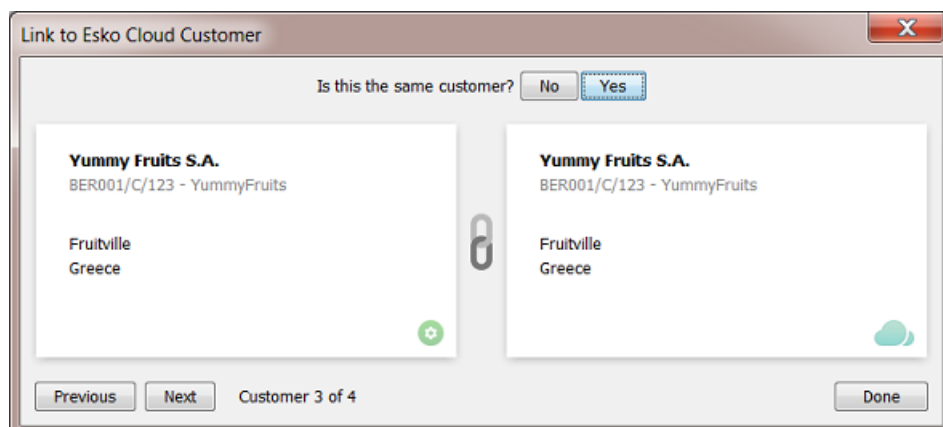

We still agree with this link. We click **Yes**.

- At any time, you can click **previous** to see the result of the previous comparisons. Or click **Next** to postpone the decision for this customer.
- This next one was also already linked. It is also part of this comparison because it was part of our selection when starting this tool.

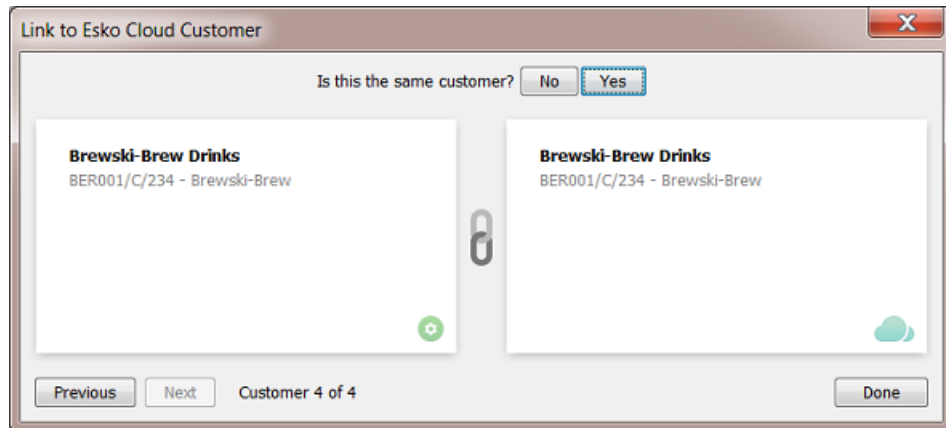



So we click **Yes**.

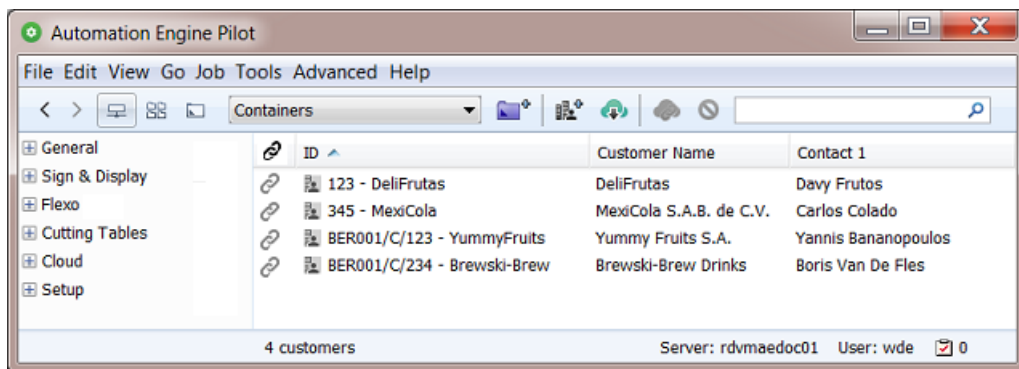

**Note:** In this example, we can also click **Done**, which means we don't answer this last question. But these two were already linked so that status will simply remain.

- The result: All our local customers are linked to some cloud customer.



**Note:** In this Pilot view, you always see your local customers only. You do not see their cloud counterparts. For a quick check, select all your customers, click  and go through the pages of this wizard.



**Note:** 2 of them have a special ID that starts with BER001/C/. This is because they were originally imported from Esko Cloud ; they were not first created locally. Learn more about this naming structure in [Import from Esko Cloud](#) on page 1701.



**Note:** There is no functionality to remove a link. You can only re-link or skip it.

### Download Changes from Esko Cloud

This tool makes the selected local customer identical to the one it is linked with on Esko Cloud.  
 This changes the settings of your local customer.



**Attention:** There is no merging of information! Also fields that are empty in the cloud will then become empty locally.

### Upload Changes to Esko Cloud

This tool makes the customer on Esko Cloud identical to the selected local customer it is linked with.  
 This changes the settings of your customer on Esko Cloud.



**Attention:** There is no merging of information! Also fields that are empty locally will then also become empty in the cloud.

### Import from Esko Cloud

- In the **Customers** view of the Pilot, click on  in the top bar or right-click anywhere in the list of customers and choose **Import from Esko Cloud...** to open the dialog where you can import a customer from Esko Cloud.



**Note:** This tool is also offered when you first selected local customers and then right-click. Your selection will be ignored in that case.

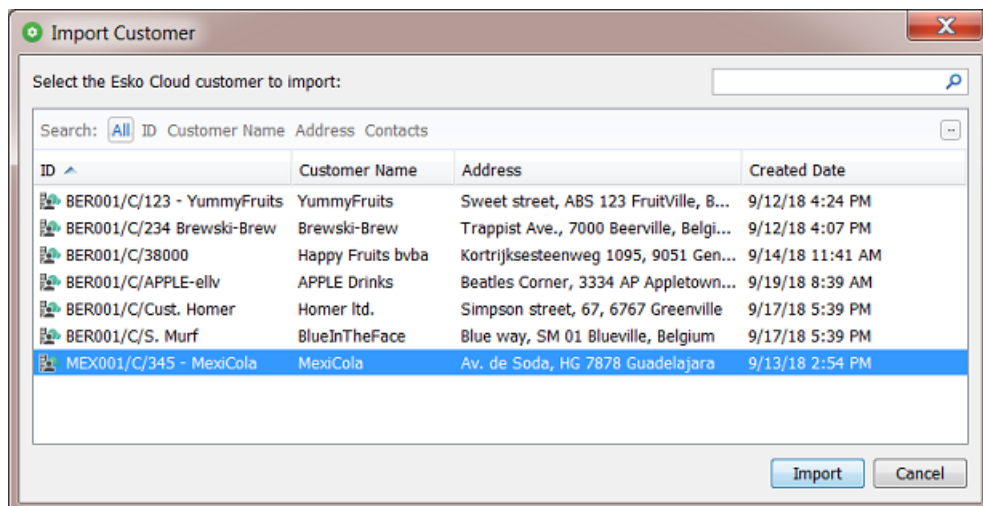

The dialog shows the list of all Esko Cloud customers of your organisation.



**Note:** The ID of a Esko Cloud customers is constructed as <MIS prefix>/C/<local-id> :

- It starts with the MIS prefix (as defined in [the Configure tool](#)). Before AE 23.07 this was the *location* from where it was first uploaded.



**Note:** The MIS prefix in the name of the customer will be stripped off when it is the same as the one defined on this Automation Engine. Otherwise, it will remain in the name.

- Then followed by "/C". This refers to the fact that, on Esko Cloud, this is a "partner" of the type "Customer" (the Esko Cloud terminology).
- And then the actual ID of that customer (in above example we also added some part of the name after the usual numbers in the ID).

- Select the one you want to import as local customer and click **Import**.



**Note:** When it was already imported, you will get a warning. You can not import it again (unless you delete the local customer first).

- A dialog appears showing you all the fields of the selected customer. We advise to click **Import** without making any changes here.

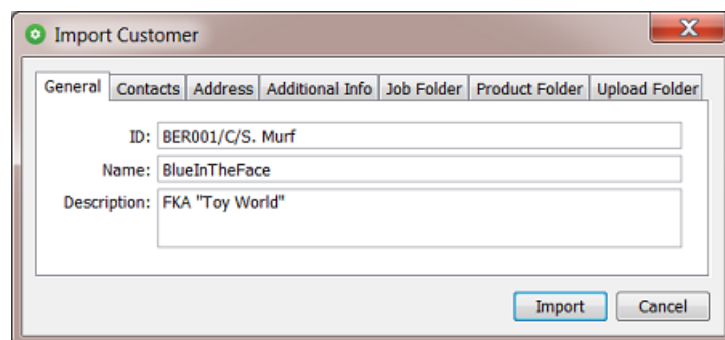

**Attention:** If you change the ID in this panel, for example by removing the initial part 'BER001/C/', you then risk creating a double or conflicting customer name. Maybe not today, but for example when your MIS later also creates such a local customer with (accidentally) that same name.

- The customer now also appears in the list of local customers. And the chain icon shows that it is linked with the one you selected in the cloud.

ID	Customer Name	Contact 1	Linked By	Linked Date
123 - YummyFruits	YummyFruits	Yann bananski	wde@rdvmae22	Sep 25, 2018
234 Brewski-Brew	Brewski-Brew	Barry Brewovic	wde@rdvmae22	Sep 18, 2018
38000	Happy Fruits bvba	Michael Jackson	wde@rdvmae22	Sep 14, 2018
777 Cookies	Cookies	Kathy Sneukeldoze		
BER001/C/6767 Homer	Homer ltd.	Homer	wde@rdvmae22	Sep 25, 2018
BER001/C/APPLE Drinks	APPLE Drinks	Ellen@app.com	wde@rdvmae22	Sep 25, 2018
BER001/C/S. Murf	BlueInTheFace	Smurf Smurf	wde@rdvmae22	Sep 25, 2018
MEX001/C/345 - MexiCola	MexiCola	Carlos Colado	wde@rdvmae22	Sep 14, 2018

**Note:** In above picture, notice how the customer 'Cookies' is the only one that is not linked to one on Esko Cloud.

### Import All Esko Cloud Customers

In the view '**Customers**', right-click anywhere in the list and select **Import All Esko Cloud Customers**.

For each cloud customer that is not yet linked to a local customer, a local customer is created and linked to that corresponding cloud customer.

You will be asked to confirm.

The MIS prefix in the name of the customer will be stripped off when it is the same as the one defined on this Automation Engine (as defined in [the Configure tool](#)). Otherwise, it will remain in the name.

This tool launches the task '**Download Customers from Esko Cloud**'. See the task's **Details** pane for more information on what it did.

This task has no options.

**Tip:** This tool is typically useful in the beginning, when Esko Cloud is being set up in your organization, or when you set up a new location.

### Upload All Local Customers

In the view '**Customers**', right-click anywhere in the list and select **Upload All Local Customers**.

You will be asked to confirm.

For each local customer that is not yet linked to a cloud customer, a customer is created on Esko Cloud. And these two are then linked.

On Esko Cloud, all uploaded customers will have been added the MIS prefix defined on this Automation Engine (as defined in [the Configure tool](#)).

This tool launches the task '**Upload Customers to Esko Cloud**'. See the task's **Details** pane for more information on what it did.

This task has no options.

## 21.4.2. On Files in Jobs

### Upload Files to Shared Job

This task uploads the selected file(s) to the matching job folder on Esko Cloud.

The input files need to be in an active (blue) Job.

When this Job does not exist yet on Esko Cloud, it will be created.

The files are placed in a folder matching the folder structure of the local job folder.



**Note:** Since AE v21.11 the path for jobs stored on Esko Cloud is based on Job Name (before, it was Job Order ID).

When same files are already in that same folder, they will be overwritten.

On Esko Cloud, a file's (modification) date is its time of arrival on Esko Cloud.

Special characters in names of files are supported.

This task has no options.

### About Task Status

- The task ends in success if all files were uploaded successfully.
- The task ends in warning if at least one file uploaded successfully and at least one could not be uploaded.
- The task ends in error if no file was uploaded successfully.

The **Details** pane shows the path on Esko Cloud where the files arrive.

### Download Files from Shared Job

#### The tool 'Download to Job Folder' in the View 'Shared Files'

This launches the task on the files you selected in the view **Shared Files** to the local job folder.

The files on Esko Cloud are not removed.

Local same files will be overwritten.

#### The Task 'Download Files from Shared Job'

- **Task Options:**
  - **Delete files from shared job after downloading:** Select this to also delete the files on Esko Cloud that were successfully downloaded.
  - This task is by default used in the [Job Sharing Access Point](#). You can there define an extra workflow to launch on the files once they arrived locally.

## Select Files on Shared Job

### Concept

This task selects files that are on an Esko Cloud job folder, or the folder itself.

This task is typically used in a workflow ticket, where the selected files serve as input for next steps like the task [Download from Shared Job](#) or the task [Start Approval Cycle on Share & Approve](#).



**Note:** The output file of this is a temporary .json file that contains a list of references to the files in the Job cloud folder.

### Settings

- **Names:**

Learn more in the pages about [Using Regular Expressions](#) on page 702, [JSONPath Expressions](#) on page 810, or [SmartNames](#) on page 637.



**Note:** When using SmartNames, the resolved values should **not** already be encoded (to avoid double encoding).

- **Path:** The task will search for the files with the here above defined names in this folder.
  - **Include subfolders**

## Remove Files from Shared Job

Use this task in a workflow after you made a selection with the task [Select Files on Shared Job](#).

## 21.4.3. On Jobs

### Sharing Jobs

#### Concept



**Note:** This was introduced in [What is Uploading? What is Sharing?](#) on page 1687.

Sharing an Automation Engine Job to Esko Cloud creates that Job on Esko Cloud. You can go a step further by also inviting other locations in your group to collaborate on this job.



**Important:** Sharing a job does not upload files. It creates the job on Esko Cloud: its job folder and the job's parameters (inks, barcodes, etc.).

You can choose to:

- Share it with one or multiple locations in your group (those that were defined for your group on Esko Cloud).
- Share it with no one, i.e. without defining any locations. Also then the job is created on Esko Cloud, but only you, the location that shared it, can see it. You could choose this for example to first collect

all the job's data on the cloud, and only once you uploaded the right files, only then share it with that other location.



**Important:** Only jobs of which the customer was linked to a cloud customer can be shared to Esko Cloud.

### The Tool 'Sharing...'

When you right-click the name of an open Job, or one or multiple jobs in the **Jobs Overview**, choose **Sharing...** to share or unshare them.

We will illustrate the possibilities with the help of some examples:

#### The 'Sharing' tool when you Selected One Job

The **Sharing** dialog opens:

- When the setting '**Share on Esko Cloud**' is not selected, this means that this job is currently not shared.



**Important:** This is also the setting to unshare a job: When you click **OK** when **Share on Esko Cloud** is not selected, you are confirming that this is what you want: The job is (no longer) shared.

- When '**Share on Esko Cloud**' is selected, the field '**Share With**' is enabled in which you can define who you want to share this job with.

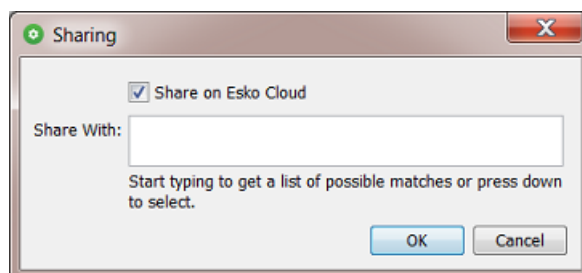

- If you leave this field empty and click **OK**, you are only sharing this job on Esko Cloud and only your own location will be able to see it and have access to it.
- If you type in one or multiple names of locations (or pick them from the list that appears), then the Pilot users in those locations will see this job on Esko Cloud and have access to it.





Click **OK** to confirm.

### The 'Sharing' tool when you Selected Multiple Jobs

In the **Jobs Overview**, select multiple jobs, right-click and choose **Sharing...**. The dialog now shows the sharing attributes that these jobs have **in common**.

Some examples:

- When your selection contains a mix of jobs that are shared and not shared, the **Share on Esko Cloud** setting will be set to '-'.



Change any setting and click **OK** to define a common behavior for all selected jobs.

Change nothing and click **OK** or click **Cancel** to not make any changes.

- In this example, all selected jobs are shared on Esko Cloud and for all of them this was with 'MEX001' (and no other location).



- When the selected jobs are all shared, but *not all* of them are shared to MEX001, then the name of that location is shown in a gray color.

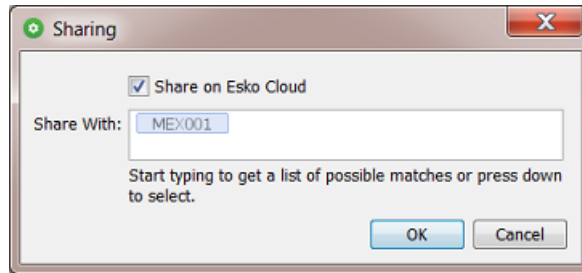

- This example shows 3 jobs with different settings in their column **Shared With**.

File Edit View Go Job Tools Advanced Help							
Job Overview							
General	Jobs						
	Name	Order ID	Shared From	Shared By	Shared Date	Shared With	
	FunkyMonk_2016	007 FunkyMonk_2016					
	FunkyMonk_2017	027 FunkyMonk_2017	<< BER001	wde@rdvmaedoc02	Oct 8, 2018	MEX001	
	FunkyMonk_2018	123 FunkyMonk_2018	<< BER001	wde@rdvmaedoc02	Oct 8, 2018	MEX001,TOK001	

When we select all 3 of them and choose **Sharing**, this is what the dialog shows:

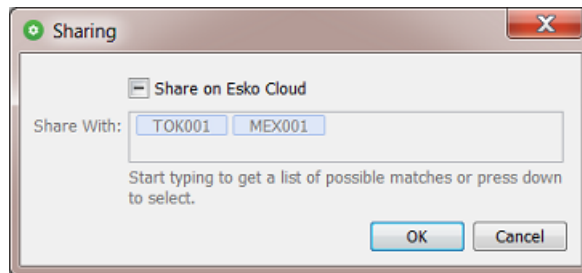

This means that:

- some of these jobs are shared on Esko Cloud, but not all (the '-' setting),
- TOK001 is shown but in gray, so at least one job is shared to TOK001, but not all,
- MEX001 is shown but in gray, so at least one job is shared to MEX001, but not all.
- We use the same jobs but now we only select the '2017' and the '2018' job.

File Edit View Go Job Tools Advanced Help							
Job Overview							
General	Jobs						
	Name	Order ID	Shared From	Shared By	Shared Date	Shared With	
	FunkyMonk_2016	007 FunkyMonk_2016					
	FunkyMonk_2017	027 FunkyMonk_2017	<< BER001	wde@rdvmaedoc02	Oct 8, 2018	MEX001	
	FunkyMonk_2018	123 FunkyMonk_2018	<< BER001	wde@rdvmaedoc02	Oct 8, 2018	MEX001,TOK001	

No the **Sharing** dialog shows this:



This means that:

- All job in our selection are shared on Esko Cloud ('√').
- TOK001 is shown in gray, so at least one job is shared to TOK001, but not all.
- MEX001 is shown but in black, so all jobs in our selection are shared to MEX001.

### The Share Job task

This task is only available as a step in a workflow. When you want to share a job that you have selected in the Pilot, this task type will not be offered. In that case, use the interactive tool '[Sharing...](#)'.

A Job is shared with one or more Esko Cloud Connections, in this context also referred to as Location with an Automation Engine server.

- **Replace existing Esko Cloud Connections:** When not selected, the changes you make in this task will be added to the current way that job is shared. When selected, and when for example the field **Share with** is left empty, the job will be unshared from all those Esko Cloud Connections (locations).
- **Unshare From:** Click on the list icon or use a SmartName.



**Note:** This field is case-sensitive. When defining multiple, it should contain a comma separated list of names of Esko Cloud Connections.

- **Share With:** Click on the list icon or use a SmartName.



**Note:** This field is case-sensitive. When defining multiple, it should contain a comma separated list of names of Esko Cloud Connections.



**Note:** You can still share with an Esko Cloud Connection that shows a red status when checking the [Network \(Server Admin Web Page > Server Checks\)](#) . Once that Esko Cloud Connection becomes available again to Esko Cloud, the sharing will be done.



**Note:** The task first executes the items in **Unshare From**, and afterwards those in **Share With**.

### The Unshare Job task

This task unshares the job or jobs that were selected or, in a workflow, that were specified as input files.

The job will be removed from Esko Cloud, including the files it stored there.

This task has no options.

### Synchronize Job - All Jobs

This function is available when you select a Job that was already shared on Esko Cloud. It synchronizes all fields of the job setup of this Job. For example: a change in the list of inks or barcodes.

Normally, all changes in a job setup between the local and the cloud job (aka 'events') are automatically exchanged.

However, this automatic synchronization between AE servers and Esko Cloud will (temporarily) fail:

- When your Automation Engine server is unavailable (due to a software update, computer reboot, etc.).
  - In this case, the Automation Engine software will also repair this automatically: As soon as the Automation Engine software re-starts, the server automatically launches a task that does this synchronization and so makes up for any lost 'events'. There is an [upload-](#) and a [download version of this synchronization task](#).
- When there is no internet access for a while.
 

This could be your own link to Esko Cloud or it could be another location that lost its connection. During that network problem, this of course prevents that location to send or pick up any changes in jobs on Esko Cloud.

  - This is the case where you use the 'Synchronize Job' tools. You can either right-click a job and choose **Synchronize Job**. Or you select **Synchronize All Jobs** from the menu **Job**.

### The Synchronize with Esko Cloud (Upload) task

When your Automation Engine server restores its connection to the internet, this task will make sure that the changes you made locally are uploaded to Esko Cloud.

This task is started automatically by Automation Engine.

You can also trigger it yourself by using the **Synchronize** tools in the **Job** menu. Learn more in [Synchronize Job - All Jobs](#) on page 1710.



**Note:** When you open this task after it has been started, you will see task options. These are only there for the use by Esko support staff. This enables them to test the effect of these options in case something went wrong.

### The Synchronize with Esko Cloud (Download) task

When your Automation Engine server restores its connection to the internet, this task will re-download all Esko Cloud jobs on which your location is collaborating, to make sure you have the latest job info, parameters and inks.

This task is started automatically by Automation Engine.

You can also trigger it yourself by using the **Synchronize** tools in the **Job** menu. Learn more in [Synchronize Job - All Jobs](#) on page 1710.



**Note:** When you open this task after it has been started, you will see task options. These are only there for the use by Esko support staff. This enables them to test the effect of these options in case something went wrong.

## Pilot View 'Shared Files'

### A new Pilot View mode to see a Job's Shared Files on Esko Cloud

In the **'Last used Job'** mode of the Pilot (when you opened a Job), the extra view **'Shared Files'** becomes available in the category **'General'**.

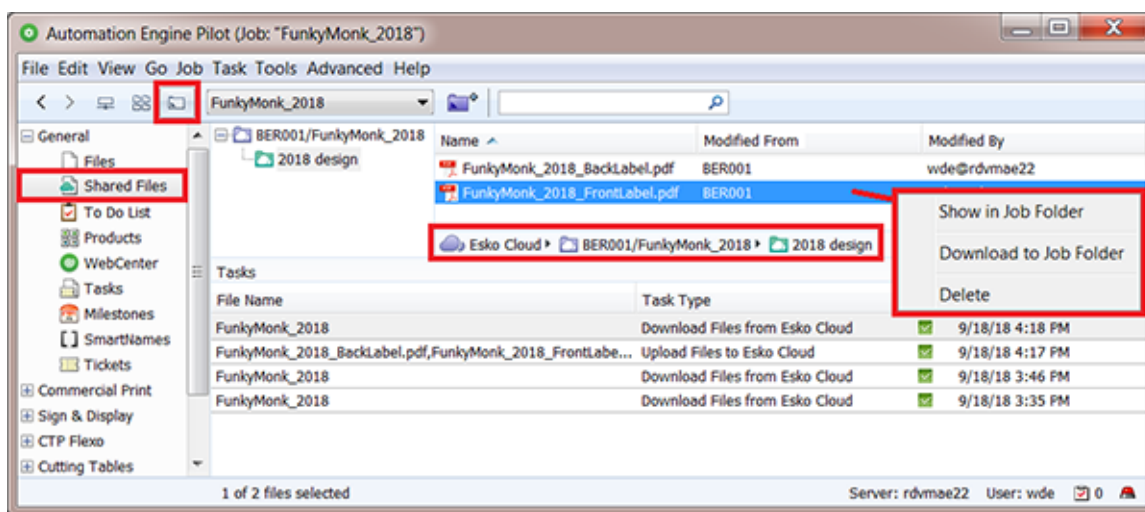

This view shows this job's folder on Esko Cloud and the files it contains. These files can be put there by all who have access to this job on Esko Cloud.

### Tools in this View

Right-click a folder or a file to choose from these functions:

- **Show in Job Folder:** This takes you to the **Files** view of the local job folder and there selects the local version of the file you selected on Esko Cloud.
- **Download to Job Folder:** This downloads the folder or file(s) to the local job folder, in a same subfolder. It overwrites files with a same name.
- **Delete:** This removes the selected folder or file(s) from Esko Cloud.



**Note:** If you want to remove the whole job from Esko Cloud, then use the **Sharing...** panel. There, de-select the option **Share on Esko Cloud** and click **OK**. This will not only unshare it but also remove the job and its files from Esko Cloud.

### Smart Views on Sharing Status of Job

In the **Job Overview**, any job you can see there is a local job, a job on this AE server, on this location.



**Important:** This view does not show any jobs that are on Esko Cloud. It shows local jobs of which some could have been created because they came in from Esko Cloud.

The Jobs overview offers extra columns that provide such information:

- **Sharing Status:** A 'sharing' icon means that this local job was shared to Esko Cloud.
- **Shared From:** Where this shared job originates. (Before v22.11 this was named 'Owner Location')
- **Shared By:** The user in the remote location that shared this job.
- **Shared With:** With which locations this job was shared with.

See this example of the Jobs in the location BER001.

These are all the (live) jobs on the Automation Engine server in BER001:

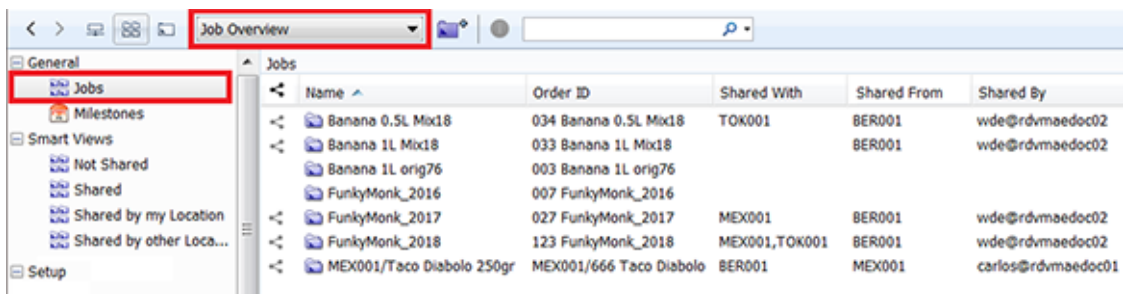

Name	Order ID	Shared With	Shared From	Shared By
Banana 0.5L Mix18	034 Banana 0.5L Mix18	TOK001	BER001	wde@rdvmaedoc02
Banana 1L Mix18	033 Banana 1L Mix18		BER001	wde@rdvmaedoc02
Banana 1L orig76	003 Banana 1L orig76			
FunkyMonk_2016	007 FunkyMonk_2016			
FunkyMonk_2017	027 FunkyMonk_2017	MEX001	BER001	wde@rdvmaedoc02
FunkyMonk_2018	123 FunkyMonk_2018	MEX001,TOK001	BER001	wde@rdvmaedoc02
MEX001/Taco Diabolo 250gr	MEX001/666 Taco Diabolo	BER001	MEX001	carlos@rdvmaedoc01

### Smart Views offered when using Esko Cloud

You automatically get a few Smart Views that help filtering jobs in relation to Esko Cloud.

To enable these views for the current user, right click the icon of the Jobs view and select **Manage Filters....**



**Note:** These extra views can only appear after you have set up an Esko Cloud configuration in the **Configure** tool and after a restart of the Pilot.

Double click the name of a **Smart View** to see how its filter is built up:

- **Not Shared:**

These are our jobs that are not shared on Esko Cloud.

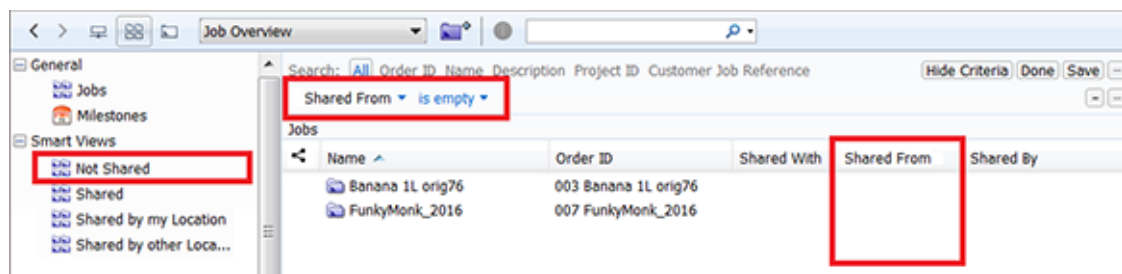

Name	Order ID	Shared With	Shared From	Shared By
Banana 1L orig76	003 Banana 1L orig76			
FunkyMonk_2016	007 FunkyMonk_2016			

- **Shared:**

These are all the jobs that our location has access to on Esko Cloud.

See how the filter uses **'None'** to get a reverse effect:

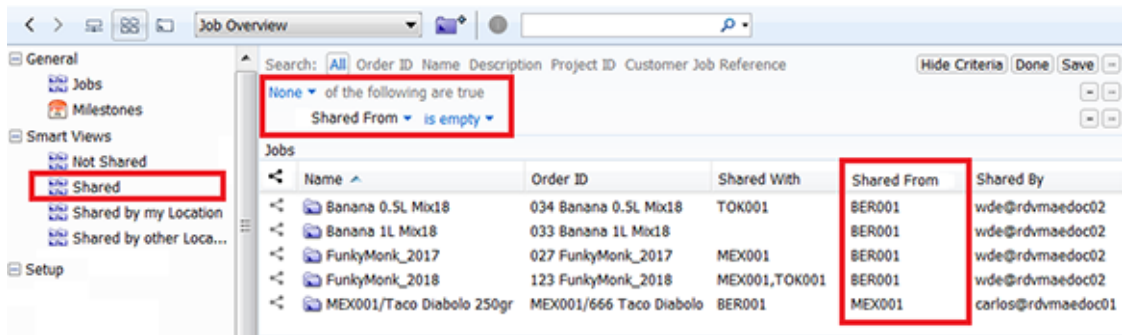

These jobs job are either:

- our own jobs **that we shared** on Esko Cloud (4 from BER001),
- or jobs **that were shared to us**. We were invited to see them, which then automatically created this local version of that job (1 was shared to us by MEX001).

- **Shared by My Location:**

These are all the jobs that our location has shared on Esko Cloud.

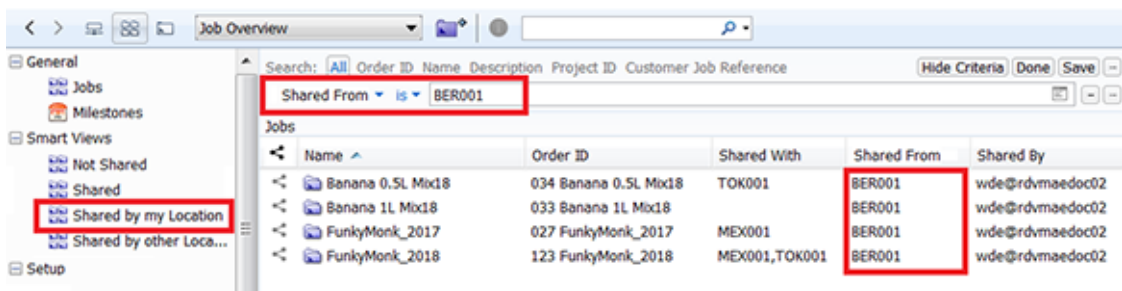

- **Shared by Other Locations:**

These are all the jobs that were shared to us by another location.

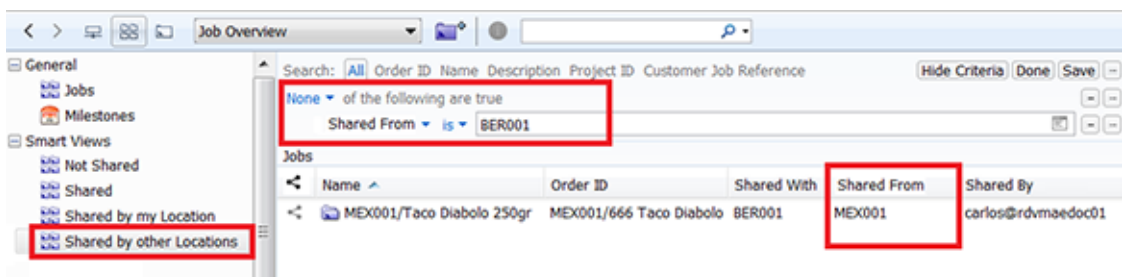

**Note:** If you don't want to use or see these Smart Views, just de-select them in **Manage Job Filters** from the **Job** menu.

### Smart Views on Cloud related Tasks

The first time a Pilot opens after adding an Esko Cloud site in the Configure tool, some extra **Smart Views** will be added that help you filtering cloud related tasks.

- The Smart View **CloudJob-Import-failures** shows the **Create Job** tasks that, after an invitation to collaborate on a cloud job, failed to create a local job.
- The other Smart Views are about Tickets. Learn more in [Smart Views on Cloud Tickets](#) on page 1716.

If you don't want these Smart Views, go to the **Tasks** view and just de-select them in **Define Task Filters** in the **Task** menu.

## 21.4.4. On (Workflow) Tickets

### Concept

You can submit (workflow) tickets to Esko Cloud, only global (yellow) tickets, not (blue) Job tickets.

The main use case is to make them available to other locations, to streamline how you work with Automation Engine in different locations.

By uploading these tickets to Esko Cloud, workflow administrators (in headquarters?) can so make a catalogue of interesting workflow tickets available for all locations within the organization.

A ticket on Esko Cloud also contains all its dependencies, like SmartNames, template files, etc.

Tickets on Esko Cloud are not related to any customer of job. They are there to be seen and picked up by any other of your locations (not specific ones).

Mind that all steps are manual, i.e. there is no automatic synchronisation of versions of tickets. This is because updating tickets on another location while they could be in use is not secure at all.

However, the system does automatically keep track of any changes and show this with an icon (see below). But it will not make any decisions itself.

You decide which tickets you want to submit to Esko Cloud and when. The receiving locations decide when and what they want get.

There are no tasks doing this, only manual tools.

There is no record of history nor versioning of tickets.

### The 'Cloud Status' in the Tickets View

The **Tickets** view in the Pilot is where you see the **'Cloud Status'** of a ticket. This is the status related to its counterpart on Esko Cloud.

This **'Cloud Status'** is now also a category you can search or filter on.

Select the columns **Cloud Status** and **First Submitted From**.





These are the possible states that a ticket can have:

-  **Unlinked**: This ticket is not on Esko Cloud. In this filter, select this icon to see unlinked tickets.



**Note:** In their cloud status column, unlinked tickets do not show this icon but show no icon at all.



-  **Synced:** The ticket on Esko Cloud is in sync with this local ticket.
-  **Updated:** Your location updated the ticket which is now newer than the one on Esko Cloud. You need to consider submitting this newer version to Esko Cloud.
-  **Outdated:** Your local ticket is outdated. Another location updated the ticket on Esko Cloud.
-  **Needs Linking:** In this case there are 2 problems:
  - The ticket on Esko Cloud shows changes that are not present in the local one
  - And there are changes in the local ticket that are not present in the one on Esko Cloud.

There is no easy way to solve this. The only option would be to save a copy of your ticket locally, then download the latest version from the cloud and then apply your changes again to that latest version.

-  **Removed:** This ticket has been on Esko Cloud but is now no longer there. It has been removed.



**Important:** Only **direct changes** to the ticket are seen as modifications that will change the cloud status to **'Updated'**. Changes to a SmartName or to a referred ticket will not have an impact on the cloud status of the main (workflow) ticket.

### Importance of Time Synchronisation



**Attention:** To know if a ticket is outdated or in sync, Automation Engine compares modification dates. For this to work, the clock in the Automation Engine server should differ no more than 20 seconds from the clock on Esko Cloud.

### Submit to Esko Cloud...

Select one or multiple tickets, of any type.

The system ZIP's the ticket together with all its dependencies and then uploads this set to Esko Cloud.

At each submit of a new 'version', a change-log can be attached. This information is available as a column in the dialog [Import Ticket from Esko Cloud](#).

### Get Latest Revision from Esko Cloud

To update a local ticket with the latest version of the cloud ticket, go to the **Tickets** view, make a selection, right-click and choose the entry **Get Latest Revision from Esko Cloud**.

### Import Ticket from Esko Cloud...

From the **Tickets** menu, select **Import Ticket from Esko Cloud...** to import a ticket from Esko Cloud.

In case this import action would overwrite a local resource (a ticket, a referenced file, a SmartName...), then you will be shown some details and asked to confirm.

In the list, the column **Changelog Description** shows what was added when using the task (or manual tool) of [Share Workflow Ticket](#) and [Submit to Esko Cloud](#).

### Remove from Esko Cloud

In the **Tickets** view, select one or more tickets, right-click and choose **Remove from Esko Cloud**.

You will be asked to confirm.

Only a user in the location where it was **First Submitted From** can remove a ticket from Esko Cloud. This is the location that submitted it to Esko Cloud.

At any other location where this ticket had already been downloaded, the ticket is kept as a local ticket. The cloud status of the local ticket will change to  **Removed**.

## Smart Views on Cloud Tickets

### Some Examples

Some examples of how you can filter your local tickets based on their cloud status:

- Your local tickets that this location ('BER001') has submitted to Esko Cloud:

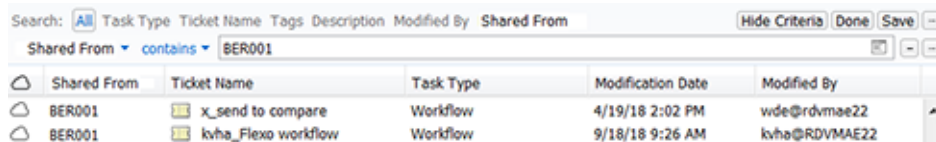

Shared From	Ticket Name	Task Type	Modification Date	Modified By
BER001	x_send to compare	Workflow	4/19/18 2:02 PM	wde@rdvmae22
BER001	kvha_Flexo workflow	Workflow	9/18/18 9:26 AM	kvha@RDVMAE22

- Your local tickets that have a counterpart on Esko Cloud:



Search: All Task Type Ticket Name Tags Description Modified By Shared From Hide Criteria Done Save

Shared From contains BER001

Cloud status is [cloud icon] [local icon] [sync icon] [out-of-sync icon]

None of the following are true

- Your local tickets that were downloaded from Esko Cloud, but who are out-of-sync because their cloud version was updated:

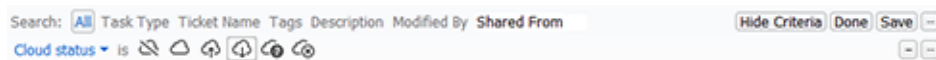

Search: All Task Type Ticket Name Tags Description Modified By Shared From Hide Criteria Done Save

Cloud status is [cloud icon] [local icon] [sync icon] [out-of-sync icon]

- Your local tickets that were downloaded from Esko Cloud, but who are out-of-sync because their local version was updated:



Search: All Task Type Ticket Name Tags Description Modified By Shared From Hide Criteria Done Save

Cloud status is [cloud icon] [local icon] [sync icon] [out-of-sync icon]

### Smart Views offered at installation

Just like with Jobs, you are presented an example Smart View.

- The Smart View **CloudJob-Import-failures** shows the **Create Job** tasks that, after an invitation to collaborate on a cloud job, failed to create a local job.

Double click a Smart View to see how it is constructed.

## Share Workflow Ticket

### Concept

This task enables an administrator to send workflows to other locations of a same company that also have an Automation Engine server. When a ticket with the same name exists on that server, it will be overwritten / updated.

When no destination location is specified, the task will only upload the workflow ticket to Esko Cloud. Another location can then import it at will by using the manual tool 'Import ticket from Esko Cloud'.

When imported at another location, the ticket's resources will always be overwritten marks, tickets, SmartNames, action lists, ...).

The modification dates of the ticket and the SmartNames it uses will be updated.

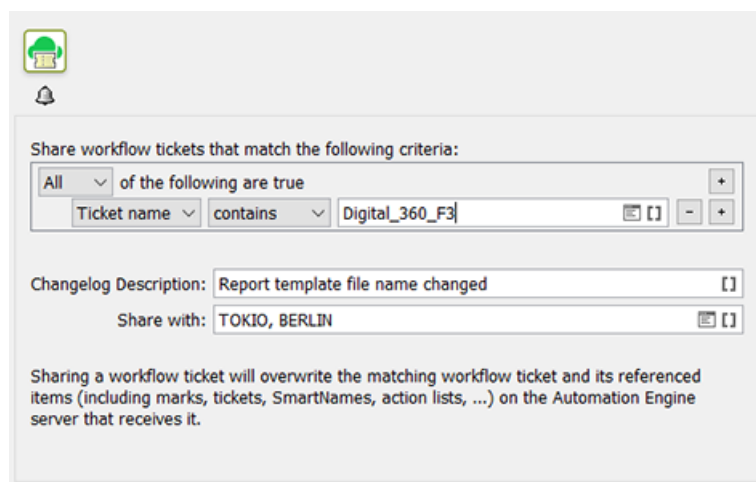

The task can be launched either after selecting a workflow ticket in the Tickets view or as a step in a workflow.

This task will fail ...

- when it was launched by a non-admin user.
- when there is no connection to Esko Cloud (or not *configured*)



**Note:** This is the task version of the same functionality offered when you select a workflow ticket and choose 'Share' (in the *Tickets view*).

### Task Settings

- **Changelog Description:** Typically a description of what was changed in this workflow ticket.

This info is visible in dialog of the *Import ticket from Esko cloud* tool in the Pilot. The administrator of a location can with this info decide to manually import it or not (yet).

- **Share with:** Define/select the Esko cloud connections (locations) that this ticket should be sent to. Technically the AE servers at these locations are instructed to import that ticket from Esko Cloud.

When all here defined locations have successfully imported all shared tickets, the task ends successfully. When only some of them, the task ends in warning. When none of them, the task ends in error.

When no response is received from one of the shared Esko cloud connections within 5 to 10 minutes, the task is automatically canceled. This could be for example because one of the Automation Engines is down or not connected to Esko Cloud at the moment of sharing.

The task does not do any form of automatic retrials.

## 21.4.5. Job Sharing Access Point

### Concept

On this page, we assume you already understand the main principles of **Access Points** as described in the chapter [Integrating with External Systems](#). Here's a [direct link](#).

The most typical aspect of an Job Sharing access point, and its main difference with the other types of access points, is that the folder that will be scanned is not one specific folder but each folder with that name in **every** job on Esko Cloud.

### Setting up a Job Sharing Access Point



**Note:** We advise that you first establish the link between your Automation Engine and your Esko Cloud site. Do this in the **Configure** tool.

Follow these steps to set up a Job Sharing access point:

- In the Pilot, go to the view **Access Points** (part of the category 'Setup').
- In the toolbar, click to create a new access point.
- In the dialog, choose the type "Job Sharing" and click **OK**.



**Note:** Before v21.11, this type of access point was named 'Esko Cloud Access Point'.

- Add a logic and clear **Name**. Optionally, add a **Description** of what this access point will do.
- In the tab **Esko Cloud Settings**:
  - **Account:** This is the name of your configuration. When you still need to create one or just see its details, click **Configure**.
  - **Folder:** This is the name of the folder that will be monitored in **every** Esko Cloud job folder that is accessible to this location. An example:



**Attention:** The name of this folder is case sensitive.



**Note:** There is no need to start this field with a "/" .



**Note:** When the folder is a subfolder of another one, use a "/" in between. For example: Outsource/3D work.

- In the tab **Automatic Actions:**
  - **Move Files To:** The files that are found in such a folder are moved to the corresponding local job folder (which was created automatically).
  - **Action:**
    - **None.** Choose this option when you only want to use this **Access Point** to *move* the files.
    - **Workflow.** Choose this option when you want a workflow to start. Select the workflow ticket from the offered list. The new accessed files will be used as input files for this workflow. If these files are inside a Job Folder, the workflow will be run in the context of that Job.



**Attention:** Make sure your workflow **can** start with the type of files that will arrive.

**Options:**

- **Operator:** Choose the user that will be shown as user for the workflow task.



**Tip:** If you do not want to assign one specific person, you could create an operator named "Access Points" or "Automatic" and assign that one here. Also remember that the Access Points Task Monitor shows you the tasks launched by the selected Access Point.



**Note:** If you leave this option blank, a system user "UPLC" will be used.

- **Priority:** Choose the priority for this workflow: Low, Normal or High. The default priority is 'Normal'.

**Folders which are named after one of your Esko Cloud locations**

An Job Sharing access point will not download files from a folder name that is the name of a location, except when it is the name of its own location. In other words: It will consider and download all files, except in subfolders named after other locations.

This setup enables an easy way of distributing files over several locations.

An example:

This local job folder has a sub folder 'External Work' that is being scanned by an access point in each of 3 other locations, named 'MEX001', 'SYD001' and 'TOK001'.

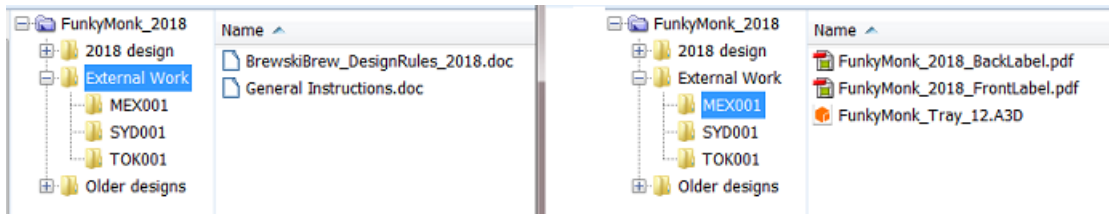

- The access point at each other location will download the 2 \*.doc files in the folder 'External Work'.
- The location 'MEX001'
  - will not download anything from the folders 'SYD001' or 'TOK001'
  - but will download anything else in 'External Work', which in this case is all the files in the folder 'MEX001': the 2 PDFs and the A3D file.
- The location 'SYD001'
  - will not download anything from the folders 'MEX001' or 'TOK001'
  - but will download anything else in 'External Work', which in this case is all the files in the folder 'SYD001'.
- The location 'TOK001'
  - will not download anything from the folders 'MEX001' or 'SYD001'
  - but will download anything else in 'External Work', which in this case is all the files in the folder 'TOK001'.

### 21.4.6. SmartNames related to Sharing via Esko Cloud

This workflow introduces these new SmartNames:

- **Esko Cloud Connection:** The name in the Esko Cloud configuration for this location with Automation Engine.  
This name is also shown in the Pilot, in the bottom info bar.
- **Job Shared From:** The name of the Esko Cloud Connection from where the job was first shared to Esko Cloud.  
(Before v 22.11, this SmartName was called the 'Job Owner Location').

## 21.5. FAQs on Technical Setup

---

### Which AE user executes these AE tasks?

Any AE user that uploads a file or shares a job to Esko Cloud will trigger a task that is, as usual, run on behalf of that user.

The [Synchronize with Esko Cloud](#) tasks however start automatically and are launched by a user (aka 'operator') named `auto@<name-of-location>`.

All access to Esko Cloud is done through the use of the token. The Esko Cloud site so also gets confirmation on which 'equipment' is connecting to it.

### **Which communication lines are needed to enable collaboration between Automation Engines in different locations?**

In each location, the (master) Automation Engine server (AE 18.0.1 or higher) needs to **be connected to the internet**.

With the necessary authorization and permissions, this allows one location to put data in a particular place on Esko Cloud and another location to retrieve the data from that place in the cloud. The communication between these locations always passes over Esko Cloud. In other words, it is never peer-to-peer. So, per location, 1 line to the internet is sufficient.

For security reasons, all communication happens over HTTPS.

### **Should Automation Engine servers be on the same version to collaborate?**

- AE servers on the same version can collaborate.
- Jobs shared by an AE with a lower version can be read and imported by an AE on a higher version.

Example: an AE running a version lower than AE v20 can add jobs on Esko Cloud that can be read by an AE running v21.11 .

In other words: higher versions of AE are backwards compatible with lower versions.

- Jobs shared by an AE v21.11 or higher can not be read or imported by an AE on a version lower than v 21.11 .

In other words: lower versions of AE are not forwards compatible with later versions to come. A lower version AE will not understand the new format of data that is being shared to him.



**Note:** Automation Engine does not check the version of the other AE server. This means that it is possible that a Job or its files can be shared on Esko Cloud but in the workflow do not arrive on the lower version AE server.

### **Can one group or organization have multiple 'Sites' on Esko Cloud?**

Yes, this is possible. You might for instance still want to split all data from pharmaceutical jobs away from any other data.

### **What to do when my Automation Engine server is moved to new hardware?**

Esko recommends to, create a new equipment entry on Esko Cloud for that new hardware.

### **What do I need to have access to Esko Cloud?**

Per organization (a group that owns the several locations with an AE server), 1 administrative account is needed, being a user and password (*Okta*). With this account, the data structures for the organization can be set up in Esko Cloud. These data structures can also be referred to as the 'Share & Approve' site for this organization.

**Why should I ask my IT department to make sure Time Synchronization is set up on my Automation Engine?**

Time information is stored locally in each location and also when data is put in Esko Cloud. To verify whether certain information is in sync, the time information (coming from different sources) is compared. To avoid problems with this time comparison, you need to make sure that the time as reported by your Automation Engine server is quite accurate (i.e.: being the same as respected official Time Servers).

**When cloud jobs are automatically created locally, where are they created?**

When your location is invited to collaborate on a job, a local job is created automatically on your Automation Engine (somewhere in an AE 'Container').

This is possible by making sure that the **Create Job** task uses the tool **Smart Job Location** to determine the local folder for this job.



**Important:** In this context, where Automation Engine servers exchange Jobs, the setup of this **Smart Job Location** is very important.



**Note:** The **Create Job** tasks that ended successfully are automatically removed from the Tasks view or panel.

Learn all about this tool in [Smart Job Location](#) on page 217.

An example: You could set up rules that organize job folders on a specific Container, in alphabetical groups of customers, and per year. In the **Smart Job Location** tool, in the tab **Rules**, click **Add**, and specify this:

- **Condition**
  - **If Job Field:** (SmartName) <Job Customer name>
  - **Matches:** *(?i)[a-e].\** (click 'Edit' to get help creating this regular expression)
    - and add additional rules for *[f-k]* and so on...
- **Then use as Job folder:**
  - **Container:** Select the one where you want these Job data from Esko Cloud.
  - **Folder:** <Job Customer Name for path> /a-e/jobs/2019/<Order Id for path> .
    - These <...for path> SmartNames are based on the standard SmartName with the same name but these have an extra formatting that replaces each '/' by a '-'. This way, the folder names are supported by Windows.



**Note:** Learn how to do this in [SmartNames > String Extract > Formatting Options > Text > Custom Encoding > Edit](#).

## 21.6. FAQs and Tips on Customer Consolidation

---

**How do I best start organizing these customers?**



In the beginning, when an Esko Cloud site is available and configured for your organization, there will be no cloud customers yet.



**Note:** On Esko Cloud, which serves many different types of users, customers are called **Partners**.

1. Your first step is to start uploading all the customers from 1 specific Automation Engine location to Esko Cloud, for example the one in your group's headquarter. This will also create a link between each local customer and its cloud version. This tool is named [Upload All Local Customers](#).

As soon as such a customer is linked, you can start sharing jobs and uploading some of their files to Esko Cloud.

So yes, in that first location (headquarters?), all local customers can be uploaded in 1 go.

2. For each other AE location in the group, the situation is different:

You can only start uploading files or sharing jobs once this customer link exists.

When uploading a job (sharing) for a customer that is not yet linked to a cloud customer, you must verify whether the customer already exists in the cloud.

- If so, you must manually link that local customer to that cloud customer.
- If not so, then you must first manually create a cloud customer of that local customer and then link these 2.

### How can I see if a local customer is linked to a cloud customer?

When you view the list of customers in the Pilot, make sure to add the column **'Esko Cloud Status'** to the list of visible columns (**Views > Columns**).

A link icon in that column indicates if that customer is linked to one on Esko Cloud.

### Some info fields of a customer differ between the several locations. What should I do?

Standardize! At least make some efforts on the path of standardization, in working in the same way in all locations.



**Note:** A customer's name, ID and many other attributes typically originate in a business system. Standardizing on one business system for the whole organisation will of course help to avoid that different locations have same customers with (slightly) different names or settings.



**Note:** This setup does not support actual 'mappings' of customers *between* the local AE sites. The linking is always done solely to the 'IAM' system on the Esko Cloud site.

### Is there any automatic synchronisation of customer information?

No.

This is because we don't know which system has the latest and correct customer specification. This could be the business system, but what if locations use different business systems? It could be the local one on Automation Engine. It could be the one on Esko Cloud.

Therefore, there is no automatic synchronization of customer information.

However, an AE user can always manually sync information of local customers with their cloud counterparts, or vice versa.

To upload a local customer's info to Esko Cloud, choose the task or tool [Upload Changes to Esko Cloud](#) on page 1701.

To download info from a Esko Cloud customer to the local customer, choose the tool [Download Changes from Esko Cloud](#) on page 1701.

### What happens if a 2nd (etc.) location also decides to 'Upload All Local Customers'?

[Upload All Local Customers](#) will, for each local customer, try to create a cloud customer. It tries this without already trying to automatically link a local customer to a cloud customer.

- **Success:** If such an attempt succeeds for a local customer, then there is a new cloud customer.
- However, it's possible that this customer now has 2 representations in the cloud: one that was made by the first location ('headquarter') and one that was made by this 2nd location.

Here's the problem: When you now want to share a job from this customer, it's possible that you must share 2 jobs: one based on the name given by the headquarter location and one based on the name given by this 2nd location.

Of course, the above scenario can occur for every location that decides to click on **Upload All Local Customers**. This can so end up in the worst case where you have as many representations for 1 customer as there are locations ...

- **Fail:** If the attempt to create a cloud customer from the information of a local customer fails, then this most likely means that there is already a cloud customer with information that is too similar. You now have to decide yourself, manually, what to do in this case.

You then use the tool that shows both their information side by side, and based on that you decide to link them or not ([example](#)).

### Our group installs a new AE server. Should I first import all cloud customers?

When a new (master) Automation Engine is installed in some location, it will not have any local customers yet. Here are some guidelines in the event that the new AE also needs to be linked to Esko Cloud:

- As an alternative to building that list of local customers based on those in your local business system, you could choose to **Import All Cloud Customers**. For every cloud customer, this tool creates a local customer and also links them.

So yes, on a brand new Automation Engine, you could choose to import all cloud customers.

- However, when you download a job from Esko Cloud (you accept a job invitation), then the system checks if there is already a local customer that links to the customer of the job.
  - When yes, then of course that local customer is used as customer for the imported job.
  - When not, a new local customer is created on Automation Engine and a link is made between these 2 customers.



**Important:** This means that there is a kind of auto-import of cloud customers (= creating local customers) when jobs are shared with your location.

This also illustrates the risk that a customer can get 2 representations on your local Automation Engine: one possibly made by your business system and one made by accepting a shared job to collaborate with another location.

However, there is still no real harm done. To avoid the above situation, you must do the manual effort to iterate over all the local customers to establish a link with a cloud counterpart.

## 21.7. FAQs on Collaboration Workflow

---

### Where can I see which other locations in my organization are also connected to Esko Cloud?

With a web browser, go to the [AE Server Admin web page](#) and choose **Server Checks > Network Check**.

On that page, the section **Esko Cloud Connections**, will list the Esko Cloud connections in your organization (aka 'locations') and will indicate the status of this connection to Esko Cloud.

Also, when you share a job with another location, you there also see a list of the other configured locations that you can choose to share with.

### How can I make files available to other locations?

When a location shares a job, a node is created in the data structures on Esko Cloud. The node contains meta-data about the job (parameters/inks/barcodes) but it also provides for storing files on Esko Cloud.

You can see which files of a job were uploaded to Esko Cloud right in the Pilot. Open the Job and choose the dedicated view "[Shared Files](#)".

To upload a file into the **Cloud Folder of the Job**, open a job, select local file(s) and launch the task [Upload Files to Shared Job](#). This task can also be part of a workflow ticket.

On Esko Cloud, the uploaded files are automatically placed in a folder with same name, in its same structure as the local job folder.

For example: To upload a file to the cloud in a subfolder 'Needs-Image-Retouching', you must first move the file locally into the folder 'Needs-Image-Retouching' and then upload the file to the shared job on Esko Cloud.



**Important:** It is very important to [standardize on the folder structure within jobs](#). Eventually, all locations that collaborate on a job will see the Cloud Folder of the Job. And as a result of uploading (and downloading) files to (and from) Esko Cloud, many of the subfolders in the cloud will be automatically created mirror versions of the job's subfolders in the *various* locations.

### How can I download files from Esko Cloud?

When opening a job in the Pilot, the **Shared Files** view shows all files that were uploaded for that job. In that view, you can select files, right-click and choose **Download to Job Folder**. They will be copied to the local job, in a same subfolder.



**Attention:** Also in this case, it is very important to standardize on a job's folder structure in all locations of the organization.

You can also download files from Esko Cloud by using the task [Download Files from Shared Job](#). Add this task in a workflow and you can immediately start processing these files.

### How can I see which jobs other locations shared to us?

Learn about extra columns in the Jobs overview and about [Smart Views on Sharing Status of Job](#) on page 1711.

### How do I know about failures in creating jobs triggered by an invitation from another location?

As mentioned above, when another location invites your location to collaborate on a job, a corresponding local job will be created on your Automation Engine.

This job is created by the **Create Job** task. This task can fail, probably related to linking the customer.

- To easily see which of these job creations went wrong, set these filters in your **Tasks** view: set the **Task Type** to **Create Job**, the **Source Type** on **Esko Cloud** and the **State** to **Failed**.
- **Smart Views** in Tasks view:

The first time a Pilot connects to Esko Cloud, some extra **Smart Views** will be added that help you filtering cloud related tasks. If you don't want these Smart Views, just de-select them in **Define Task Filters** in the **Task** menu.

For example: The Smart View **CloudJob-Import-failures** shows the **Create Job** tasks that, after an invitation to collaborate on a cloud job, failed to create a local job.

- An extra tool that can help in this case is to create and use a dedicated **Create Job** ticket that launches an extra workflow in case the **Create Job** task fails. This workflow could for example create a To-Do item which can request the attention of some user to check what went wrong here.

### How can I see which jobs we are sharing with which other locations?

First enable these extra columns in the **Jobs** view: **Cloud Status**, **Shared From**, **Shared By**, **Shared With**.

To see which jobs your location shares with other locations for collaboration, set these filters in the **Jobs Overview**:

- **Shared From** should be set to your own location
- and the **Shared With** field should not be empty.

The first time a Pilot connects to Esko Cloud, some extra **Smart Views** will be created that help you filtering cloud related jobs. If you don't want these Smart Views, just de-select them in **Manage Job Filters** in the **Job** menu.

The Smart View **CloudJobs-MineShared** shows you the jobs your location is sharing with others.

### The 'category' parameters of jobs are different between the several locations. What should I do?

Also here, the only answer is to work towards standardisation.

### Is Job information automatically synchronized?

Yes.

- The location that shares a job with another location in the organization, is also referred to as **Shared From** (before v22.11, this was called as 'owner location').
- When a local job is shared, the job's folders and its whole **Setup** is pushed by the 'shared from' location into Esko Cloud: job parameters, job inks, job barcodes, job preview.

- Any other location that is invited to the job (shared with), creates a local job by downloading all this job information from Esko Cloud to become a local job.
- Uploading a job setup to Esko Cloud ('sharing') can only be done by the location it was shared from.
- Downloading the setup of a job on Esko Cloud onto the local job can be done by all locations that were invited to collaborate on the job.
- When a job, in the location it was shared from, is being changed (parameters / inks / barcodes / preview), then,
  - these changes will immediately be updated on Esko Cloud
  - and from there they will also automatically be downloaded (synchronized) to the locations that collaborate on that job (where the job was shared to).



**Attention:** When a location that is not the one it was shared from does modifications to the local job, these modifications will remain local ; they are not propagated/synchronized to Esko Cloud.



**Note:** In the setup where AE locations collaborate, it is not the intention that the invited locations do modifications to the job information. The invited locations should deliver results by uploading result files into some subfolder of the **Esko Cloud Job Folder**.

### Can files automatically be downloaded from Esko Cloud?

Yes, by using an **Access Point** of the type **Job Sharing**.

This tool allows to monitor a specific subfolder within **each** job to which your location was invited to collaborate.

When it detects a file in such a subfolder, the access point will get triggered:

- It will download the file from Esko Cloud to a folder with same name in the local job. Then, the file is removed from Esko Cloud.
- Typically, a workflow is launched on that downloaded file. This workflow will run in the correct job context (this means it can use job information and job specific SmartNames).

Learn more in [Job Sharing Access Point](#) on page 1718.

### Are the folders in my job automatically synchronized?

No.

However, Automation Engine offers the tools to automate this if you want:

- Files can be uploaded into subfolders of a job's cloud folder via local workflows. This gives you full control on when to upload which files.
- Files can be downloaded automatically from Esko Cloud into the correct local job by setting up a [Job Sharing Access Point](#).

### What happens when my Automation Engine was offline for a while?

An Automation Engine server can get disconnected from Esko Cloud for several reasons: The internet connection was lost, the server was down to install upgrades or hotfixes or to do some maintenance to its hardware (additional disk space, ...).

This location could therefore have missed some events about job invitations or file uploads in subfolders that are monitored by an **Job Sharing Access Point**.

To catch up on these events, Automation Engine automatically runs a task each time its software starts up: the **Synchronize with Esko Cloud (Download)** task. This task appears in the Pilot's **Tasks** View after each start-up.

When the task ran successfully, the result should be that, regarding Esko Cloud, nothing seems to be missing (invitations and uploads are in back in sync)

**How do I share resources, like DGC curves, CMS information?**

This is not yet possible in this version of Automation Engine.

**How do I share Products?**

Typically, Products are created and modified in a context of a Job. A workflow where different AE servers want to collaborate on creating/modifying a Product should also include the sharing of that Job.

A future version of Automation Engine will enable to collaborate on a Product when it is stored on Esko Cloud.

Sharing Products, as we here describe for Jobs, will not become possible.

## 21.8. FAQs on Tickets on Esko Cloud

---

**How do I share tickets with other locations?**

Without Esko Cloud, it is possible to exchange tickets by using the **Export / Import Ticket** tools in the Pilot. This writes a ZIP file that can be exchanged via standard tools (E-mail, FTP,... ).

It is also possible to upload global (yellow) tickets to the data structures of the Esko Cloud. You can not upload job specific (blue) tickets to Esko Cloud.

Because (workflow) tickets are not linked to a customer, the nodes for uploaded tickets are stored in another data tree as the job information. Any location in the organization can see all the tickets that were uploaded.

To use an uploaded ticket in production, it must be downloaded and stored as a local ticket. Do this by choosing **Import Ticket From Esko Cloud** in the **Ticket** menu.

Many tickets have dependencies. A lot of them like SmartNames, DGC curves and marks will also be downloaded and placed or installed on the local Automation Engine.



**Attention:** This will overwrite any already existing items or files with the same name. Also mind that there is no versioning of tickets.

Any AE user can upload and download workflow tickets.

There is no automatic synchronizing of tickets. This is because the impact on production could be too intrusive.

However, there is an indication how your local ticket compares to the one in Esko Cloud:

- Should I download because someone in another location uploaded a modification to the ticket in the Esko Cloud?
- Should I upload because someone in our location made a modification to the local ticket?

To see this indication on how the local ticket compares to its cloud counterpart, make the column **Cloud Status** visible in the **Tickets** view.



**Note:** This indication is only meaningful if your Automation Engine is setup with time synchronization.

## 21.9. Workflow Examples - Combing the Tools and Tasks

### Our example group: "SuperPrint"

The group `SuperPrint` has an Esko Cloud site where it configured its 4 locations that have an Automation Engine server: Mexico City, Berlin, Sydney and Tokyo.

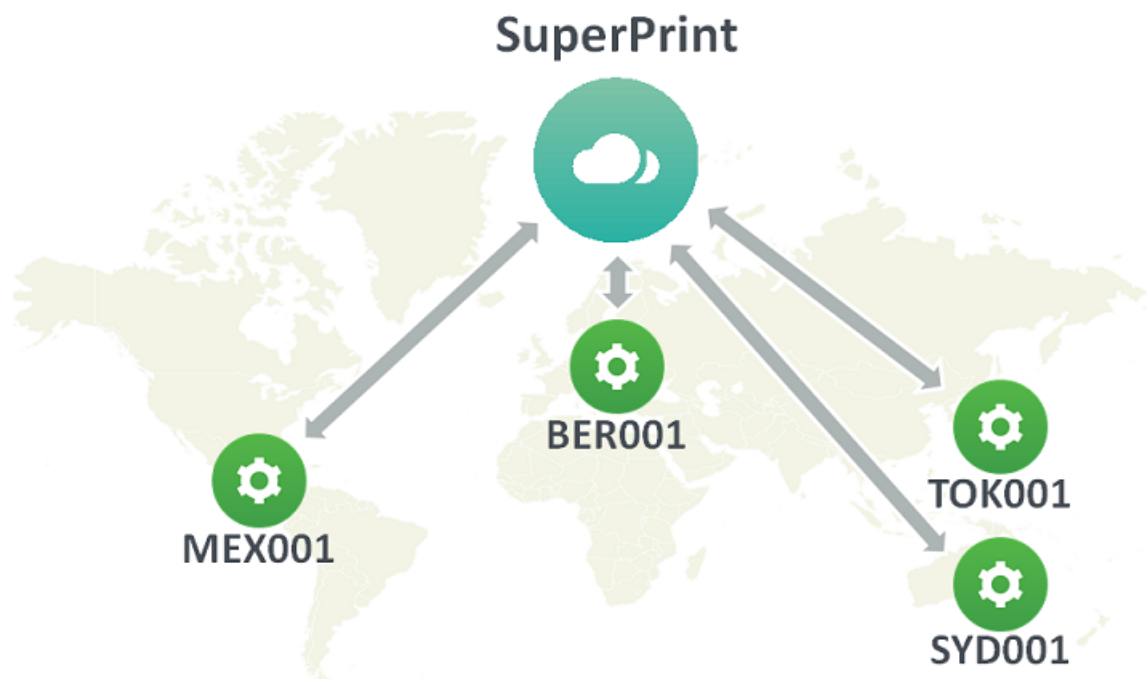

### 21.9.1. EXA 1 - Delegating work to an Other Location

#### Description of this example

The location in Berlin, BER001, regularly needs 3D models to be made of the label jobs that they prepare.

The expertise and tools to do this is only available in MEX001, the location in Mexico City.

This example shows how the users in MEX001 can automatically get the files that they need to work on.

In our case, the job name is 'Funky Monk 2018' and is for customer 'Brewski-Brew'.

### Step 1 - PREPARE - customer consolidation

As always, nothing in this example will work when the involved customer account has not yet been consolidated.

To do:

- In BER001, upload the local customer `Brewski-Brew` to Esko Cloud or link it with an existing one on Esko Cloud that also represents that same company.
- In MEX001, **Import from Esko Cloud** the cloud customer `Brewski-Brew`.

### Step 2 - PREPARE - At the location that should receive Files, create an Access Point

The 3D work needs to be done in MEX001, so they should receive the files.

To do:

- On that Automation Engine in Mexico City, create a [Job Sharing access point](#).
- Let it scan folders named '3D - To Do'.

### Step 3 - Share the job on Esko Cloud (only)

To do:

- In BER001, select the job 'Funky Monk 2018' and share it.

In our example, we will not share it yet with 'MEX001'. This way, no other location can see this job until we think it's ready.

In BER001, in the Pilot, the job now appears in the job's view '**Shared Files**'. Users in BER001 can also use '**Show on Esko Cloud**' to see it on the Esko Cloud site itself.

### Step 4 - Start uploading files to Esko Cloud

In BER001:

- Upload the files that you want your colleagues in MEX001 to get to the job's subfolder '3D - To Do'.
- You are free to upload other data from other subfolders to Esko Cloud.

### Step 5 - Now share the job with the location MEX001

- In BER001, select the job 'Funky Monk 2018' and, in the dialog '**Sharing**', in the field **Share with**, add the name `MEX001`. Confirm with **OK**.
- In MEX001, this automatically creates a local version of that job. As a reminder and mainly to keep the name unique, the name of the location that shared it (the Esko Cloud Connection) is added as prefix to the local name of the job.



Name	Customer Name	Shared From	Shared With
BER001/FunkyMonk_2018	Brewski-Brew	BER001	MEX001

  

**Job Details**

Job Name: **BER001/FunkyMonk\_2018**  
 Order ID: BER001/FunkyMonk\_2018  
 SubOrder ID:  
 Last Actor: auto (MEX001)  
 Due Date:  
 Category:  
 Customer ID: BER001/C/234 Brewski-Brew  
 Customer Name: Brewski-Brew  
 Job Folder: file:///rdvmae21/ExampleJobContainer/Jobs/BER001/FunkyMonk\_2018  
 Description:

No preview

- However, it does not show any files in that local job folder yet:

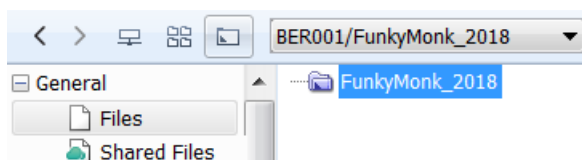

**Step 6 - BER001 starts uploading files to the Esko Cloud job that is also shared to MEX001**

- In BER001, you now have all data ready to share with the colleagues in MEX001. You have put them in a subfolder that has the exact same name as the one that was used for the access point in MEX001.

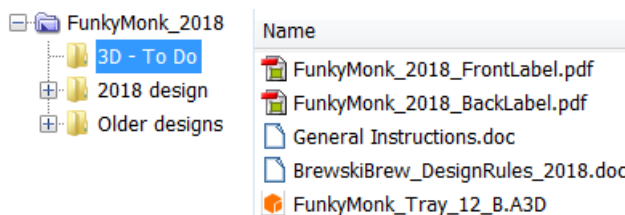

- Select all those files and launch **Upload to Shared Job**.



**Note:** It is not important if you upload them together or separate in time.

**Step - In MEX001, files are automatically downloaded (because of the Access Point)**

- In MEX001, the access point monitors the jobs on Esko Cloud that it was invited to. It detects that files arrived in the folder '3D - To Do' of the job 'Funky Monk 2018'.
- The access point downloads the files to the local job folder of 'Funky Monk 2018', where it creates a subfolder with the same name '3D - To Do' and saves them in there.



**Note:** All of this uploading and downloading happens very fast. It may even be difficult to see the files on Esko Cloud ; they are only there for a split second.

**Possible workflow extensions**

You could *notify users in MEX001 about the new incoming work*. You can do this by having the access point also launch a workflow.

Once MEX001 is done with the 3D work, you could as well automate the sending of the result files back to the location that requested them.

**21.9.2. EXA 2 - Notify Users about Problems with Jobs arriving from Esko Cloud**

This is an extension to the workflow in *EXA 1 - Delegating work to an Other Location* on page 1729. We there described how Jobs and files arrive in MEX001. The users in MEX001 can see them arrive when they look at the Jobs overview in their Pilot.

In this example we go a step further. To avoid that the users in MEX001 have to check what happens, we will adapt the workflow so that they also get a To-Do message about this incoming work.

Follow these steps:

1. In TOK001, the job 'Yakitori\_Maxi' is for customer 'Nippon Foods', a new customer. We select it, right-click and choose **Sharing**. This dialog appears because this customer is not linked yet to one on Esko Cloud:

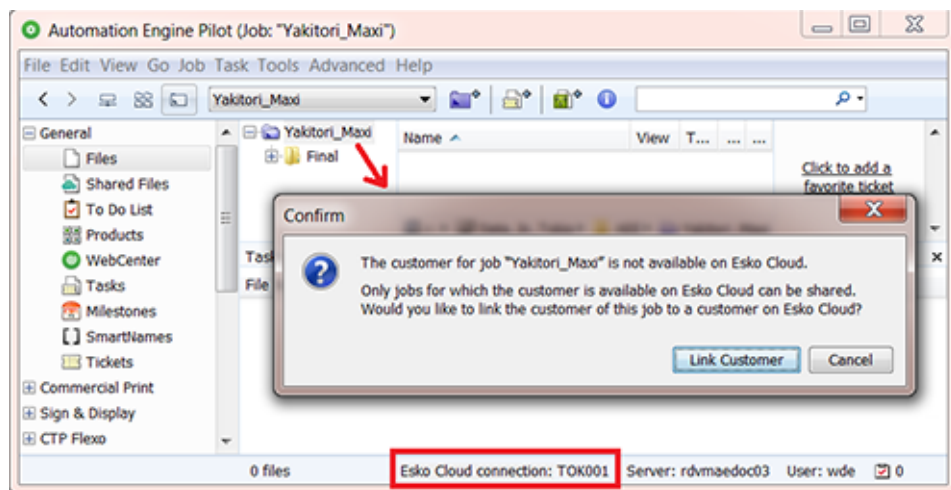

2. This linking dialog can't find a match on Esko Cloud. So we click **No**.

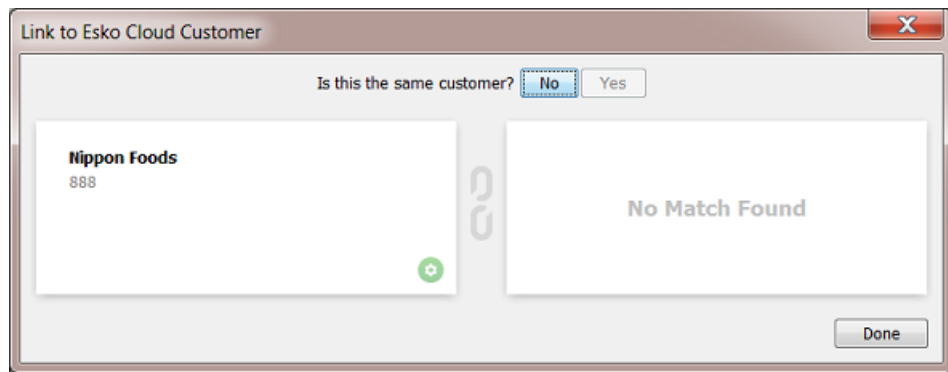

3. We use this dialog to create the Esko Cloud customer and link the local one to it.

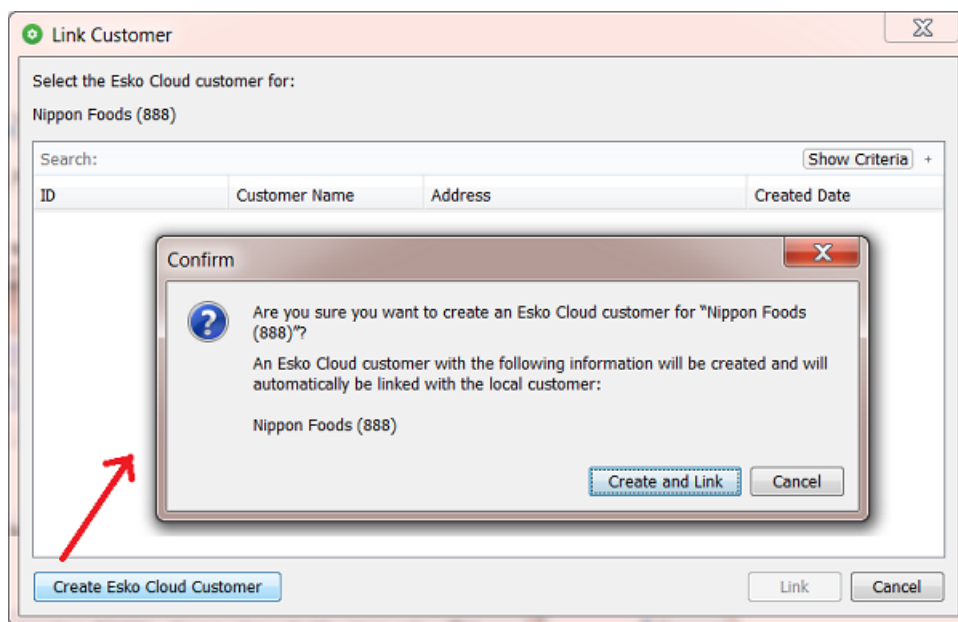

Click **Create and Link**. Both dialogs will close.

In the view **Customers**, the customer Nippon Foods will now show with a sharing icon:

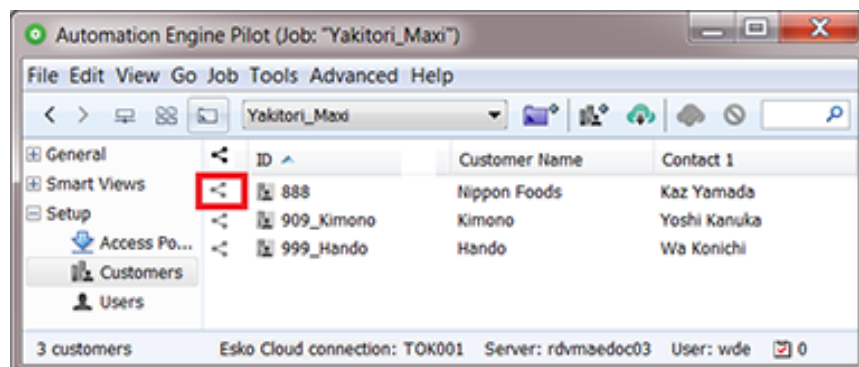

4. We now again try to share this job to Esko Cloud. We will also share it to our colleagues in Berlin:

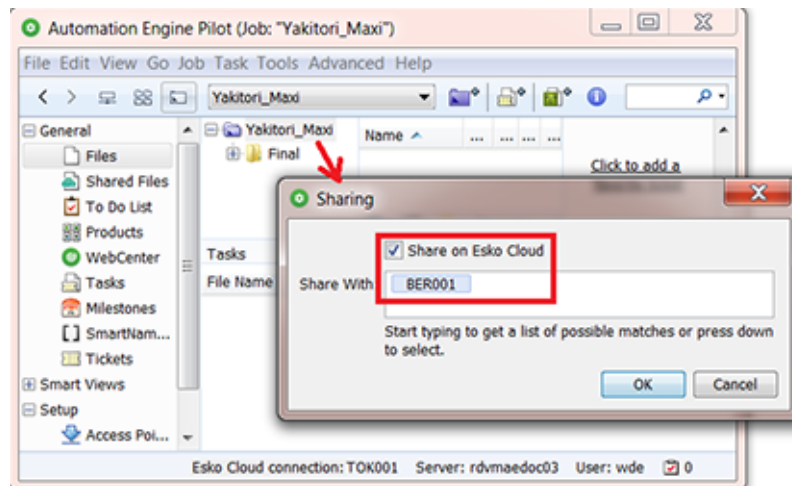

Click **OK** and see the result in the Jobs overview:

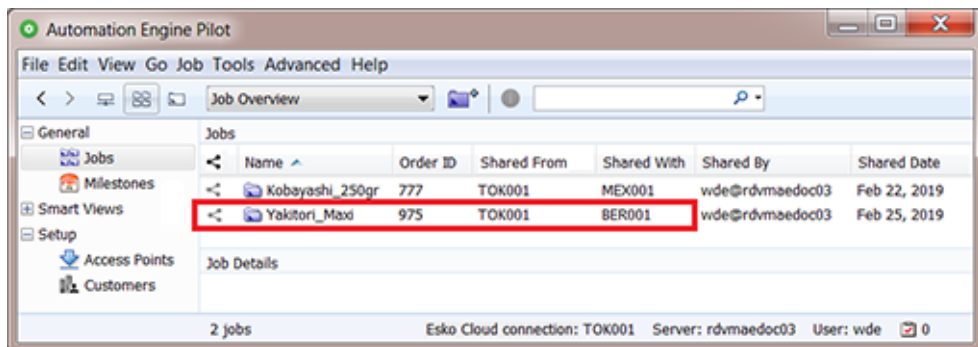

In Tokyo office, everything seems fine. We will now check what's happening in Berlin.

- In Berlin (BER001), we should see this job appear in the Smart View '**Shared by Other Locations**, but it doesn't:

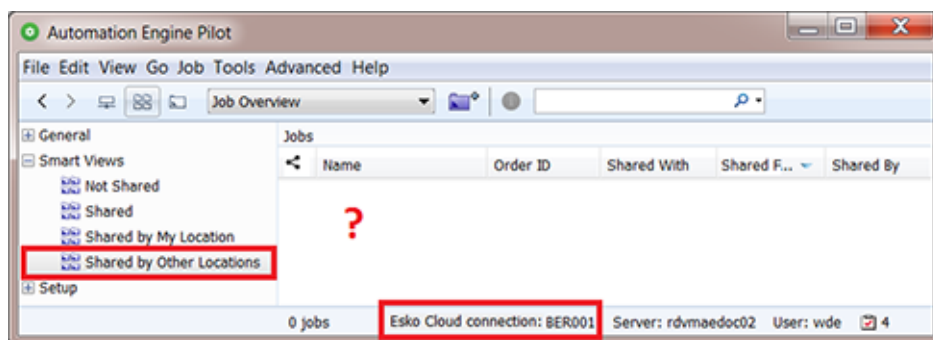

What happened? The people in BER001 could scan the Tasks view and there look for an explanation. But in this example we made it easier for them.

- The To Do list in BER001 shows a new action to respond to. Its details contain an extra piece of information at the bottom. It offers a link to find out what went wrong.

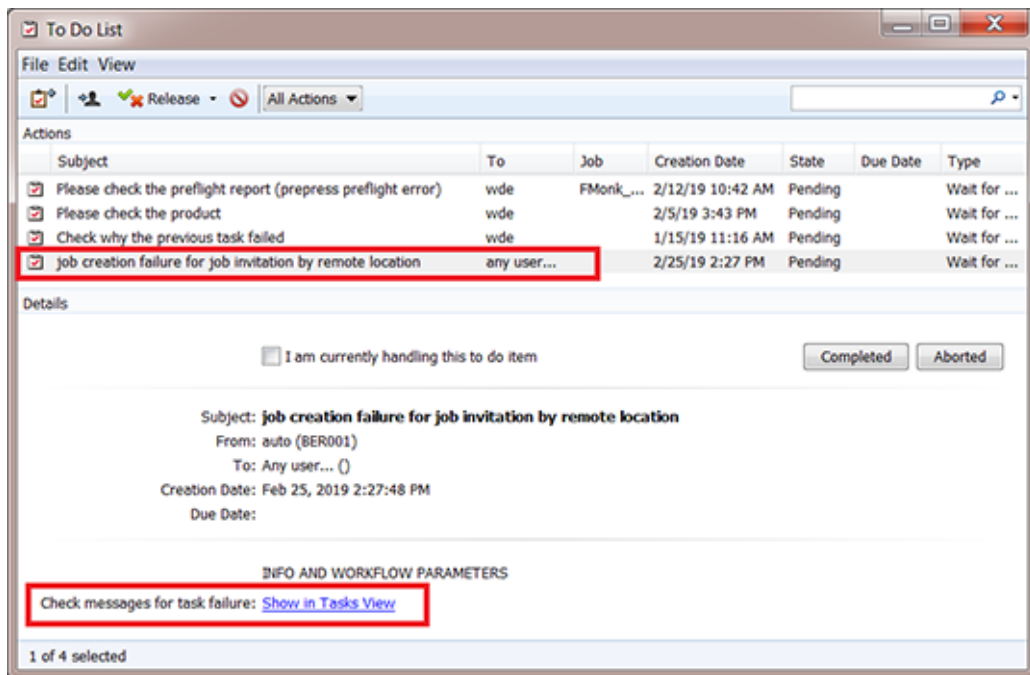

7. Clicking on this link takes the user directly to the Tasks view and selects the **Create Job** task that had a problem to create that shared job here in BER001. The task's **Details** explain why this job could not be created:

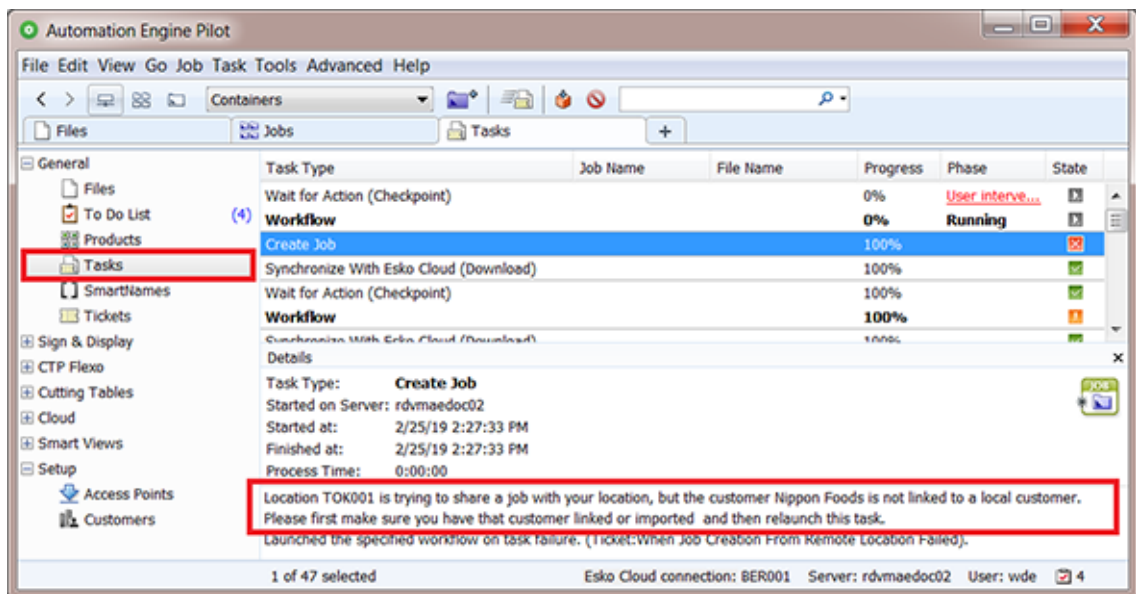

**Note:** When the To Do list is open as a separate window, and you click the link there, then the Pilot window already needs to be in the 'Containers' mode, which offers the general **Tasks** view.

Two questions now pop up:

- How can you avoid this problem?
- How can you set this up, getting a To-Do with that link?

**How can you avoid this problem?**

This typical problem can be avoid if you allow the **Create Job** task to also create that cloud customer on your local Automation Engine server. This is not an option in the task itself but part of the **Configure tool > Esko Cloud > Job Sharing**.

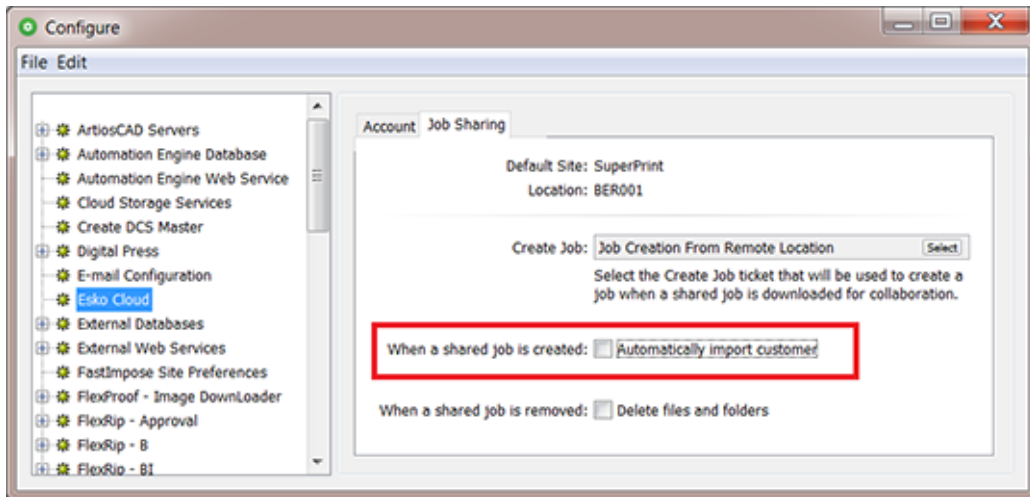

**Note:** This option is by default not selected as it can lead to local customer conflicts. As mentioned earlier, the best way to avoid those is to standardize and consolidate on customer IDs and names.

**How can you set this up, getting a To-Do with that link?**

1. When Esko Cloud is asked to share a job to a location, it will create a local job on that location's AE. The **Create Job** task ticket that is used is the one defined in **Configure > Esko Cloud > Sharing** (see above).



**Note:** By default, this ticket is one provided by Esko named **Job Creation From Remote Location**.

2. Open that ticket. In it's tab **Advanced**, see the option **When this task fails**. The ticket that is selected there is the one that we want to create a To-Do message.

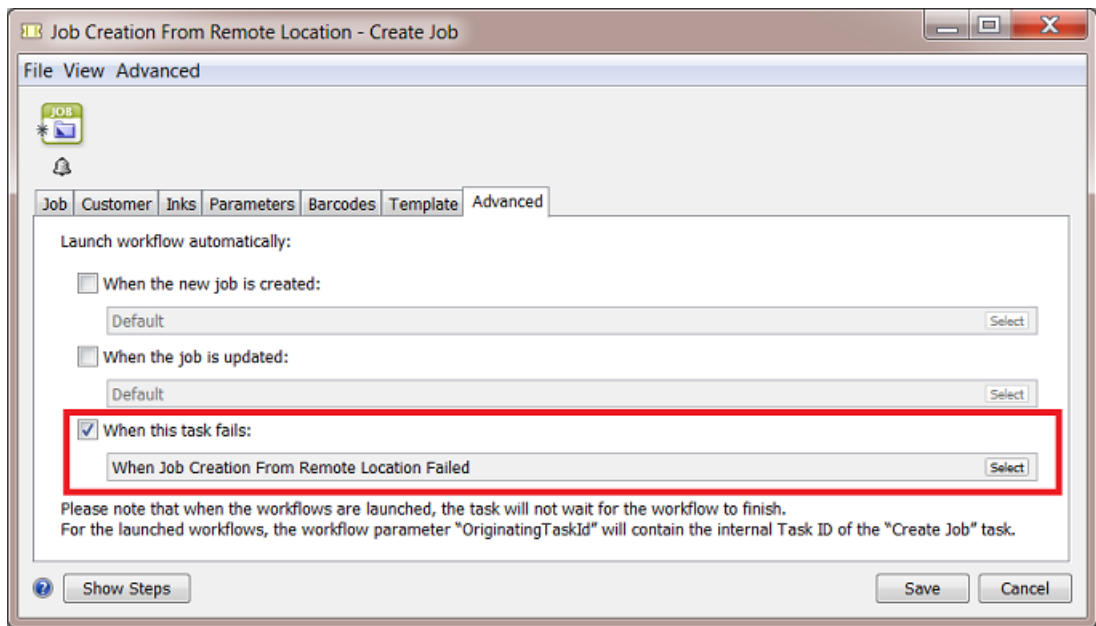

**Note:** By default, this ticket is one provided by Esko named **When Job Creation From Remote Location Failed**.

- Now open that ticket. This default one only contains the task **Wait for Action (Checkpoint)**.

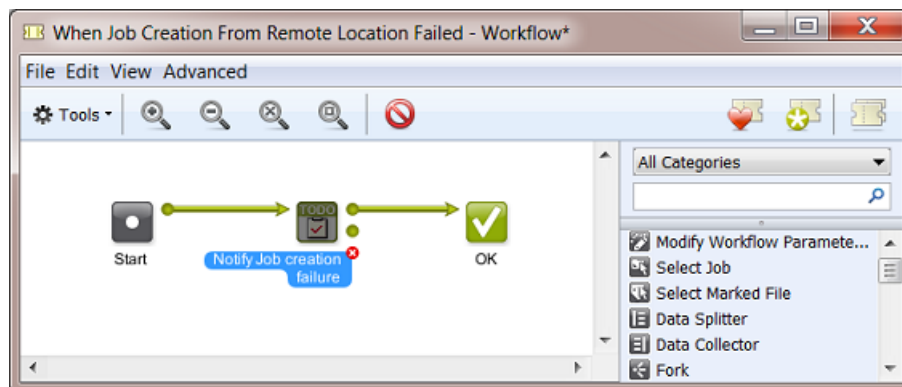

- Open that ticket and see how the To-Do option and that extra message were defined:

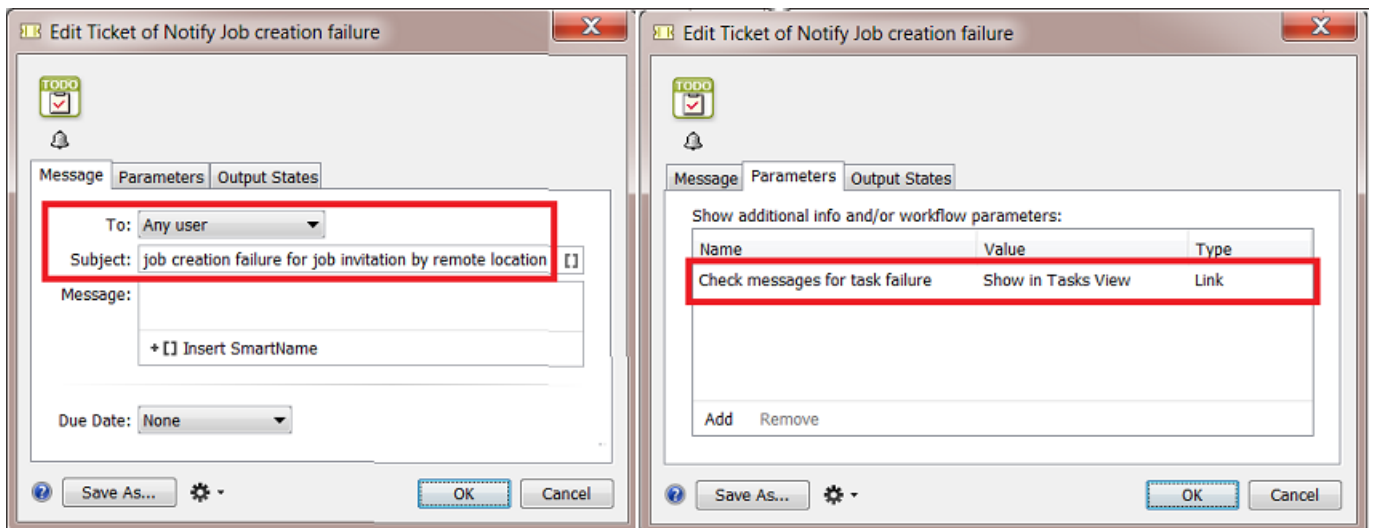

### 21.9.3. EXA 3 - Notify Users that Files have Arrived from Esko Cloud

In [Example 2](#), we learned that, when Esko Cloud wants to share a job to your location, that you can customize the tasks that start automatically. We used that to alert users when job creation from the cloud fails.

In this example we want to automatically notify users when **new files** have arrived in the local jobs that were shared to us from Esko Cloud.

Informing the users already when the job was just created locally might be too soon. In this example we wait until there are any files there to work with.

We can do this by using the Access Point that scans the cloud folder that will bring the files locally. We learned in [Job Sharing Access Point](#) that we can also here launch a workflow.

1. Let's first make that custom workflow.



**Note:** Even when you only need the action of a single task ticket, you have to make it a workflow ticket to be able to select it in the Access Point.



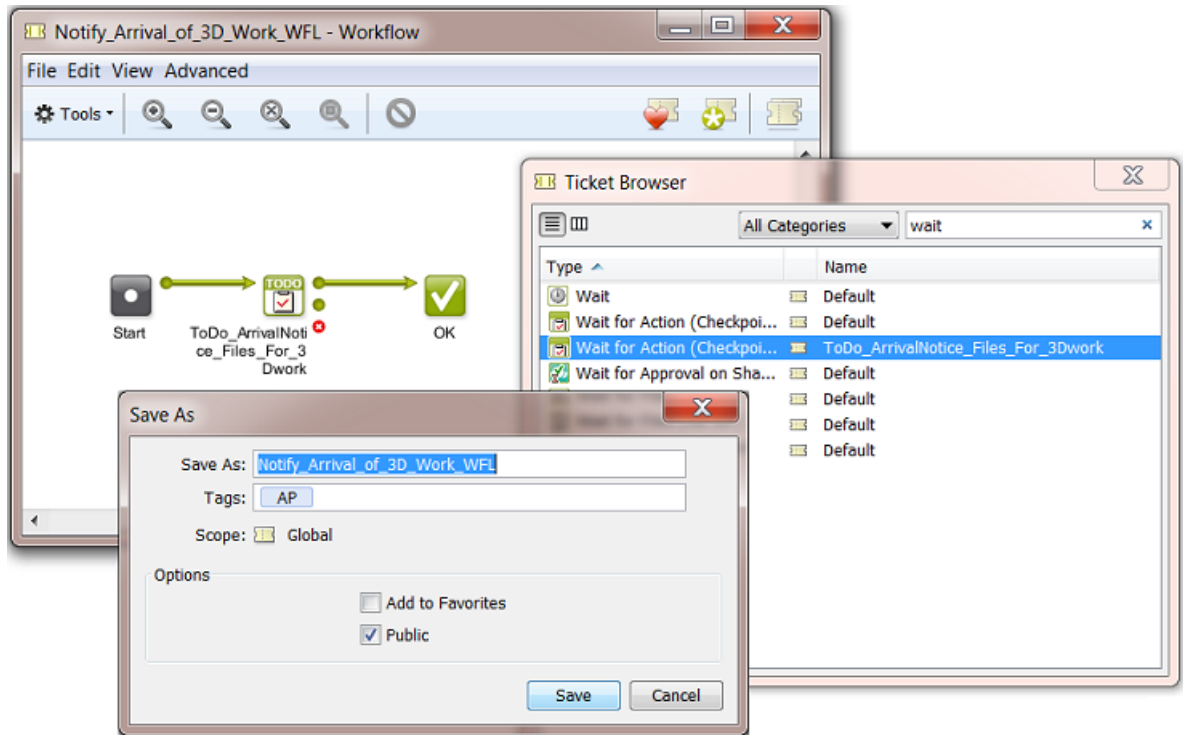

2. Then we select that workflow in the Access Point that was set up to download any such work from Esko Cloud.

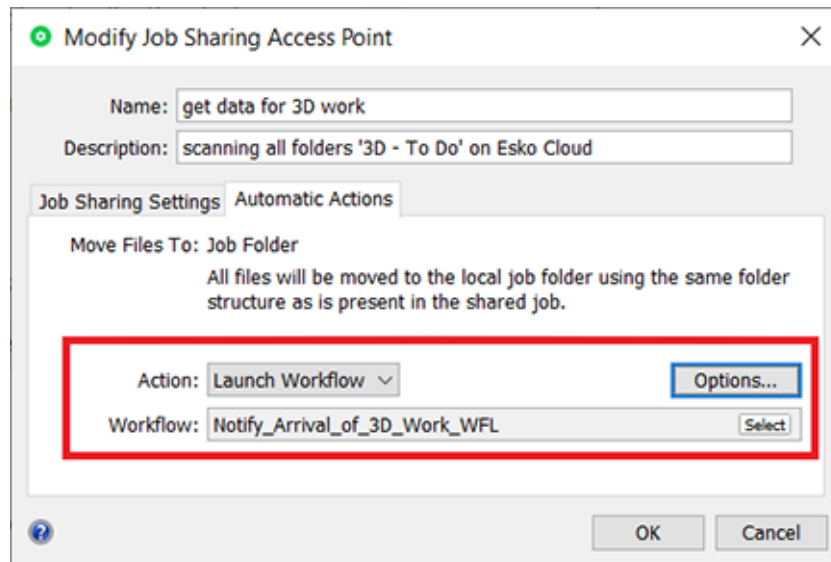

Now, when the access point downloads files, this will also create items in the To Do list (one for each file).

### 21.9.4. EXA 4 - Automatically sending the result data back to location that requested it

**Summary: In MEX001: a WFL to copy file to a "3D done" folder before Upload to Esko Cloud**

**Workflow basics:**

- The 3D specialist processes the files. When finished, he/she places the result files in a local folder '3D-work-done'.
- These result files can be uploaded to Esko Cloud, in other words, they should arrive in the 3D-work-done subfolder of the *Cloud Folder of the job*.

You can do this by launching a workflow that triggers a **Copy/Move** task followed by a **Upload Files to Shared Job**.

- Back in Berlin, the location that requested the 3D work, a **Job Sharing Access Point** monitors the subfolder 3D-work-done in any of the jobs on Esko Cloud.

When it sees the result files appearing in such a folder, it downloads these result 3D files into the folder 3D-work-done of the local job, in Berlin.

Also here, a workflow can be launched that notifies users of the arrival of these files.

- Finally, at some point, the job can be removed from Esko Cloud: an AE user in Berlin does this by unsharing the job, manually or by running the task **Unshare Job**.

Automatically, any remaining files on Esko Cloud are removed. Also in Mexico, the corresponding job is removed.

All work is done and delivered ; all cleanup at remote locations has been performed.



**Note:** A cleanup in Esko Cloud and other locations also happens when the Job is deleted locally (in Berlin) instead of only unsharing it.

## 22. Integrating with WebCenter

---

### 22.1. Introduction

---

Automation Engine is not available outside its intranet (LAN). You should see it as an *in-house* system. Automation Engine can of course be connected with many other systems. And those systems can be web-enabled. Those systems will also have a different kind of users.

WebCenter is such a system. It is typically used by

- your colleagues working in places outside the intranet (in other plants, other countries, sales people on the road etc.)
- your customers or other business partners.

If you look at **what is communicated** between Automation Engine and WebCenter, we distinguish these types:

- exchanging files: exchanging files from Automation Engine to WebCenter and vice versa.
- exchanging information: exchanging the meta data from a Job to a Project and vice versa.
- sending direct commands to the WebCenter application (advanced setups).

Let's have a look at the **main integration concepts** between these 2 Esko products:

- WebCenter users want to send instructions or data to the Automation Engine users
- WebCenter workflows contain steps that are prepress actions. These are 'sub-contracted' to Automation Engine. For example: WebCenter can not pre-flight designs, so it will ask Automation Engine to do that.
- Automation Engine sending commands to WebCenter.

#### **Publish and Approval**

New or changed designs that were made print-ready need approval from the customer. Because the customer cannot directly access Automation Engine's Jobs or Containers, the prepress department will have Automation Engine publish the document to WebCenter. WebCenter then manages this approval process with the customer and delivers the (final) answer back to Automation Engine.

#### **Using WebCenter as a centralized product management system**

WebCenter can be used to store all the prepress data centrally. Local prepress sites then download to their Automation Engine the data that they need for prepress or production tasks. This means that the files in Automation Engine Containers are actually temporary data whereas the long term data storage is then on WebCenter.



**Important:** Automation Engine does not keep track of versions of files. WebCenter does and that is important when you use WebCenter as your central storage of prepress data.



**Note:** Mind that you can choose to do this for only a *part* of your prepress data. For example only for the files of some of your largest customers where prepress production is done in different countries.



**Note:** When Automation Engine users from different sites need data from the central WebCenter storage, then several types of access rights will define what data they can see and what they can do with it.



**Note:** The parameters of a Automation Engine Product (Part) can be pushed as document attributes on WebCenter (when the document is part of a BOM).

Apart from storing the prepress data centrally on the web, WebCenter can also use Automation Engine as background server of some prepress functionality. A WebCenter workflow where your customer is working with your sales rep could include a workflow step where Automation Engine is asked to preflight the PDFs.

**Automation Engine sending commands to WebCenter**

All the above is possible through a handful of tasks and features that handle such communication. Automation Engine can go a lot further than this and instruct WebCenter in much more detail. Some examples:

- Automation Engine managing WebCenter users, groups, customers (create, delete...).
- Automation Engine managing WebCenter documents (download, download metadata, delete, set attributes...).
- Automation Engine managing WebCenter projects (create, manage members, get lists, get document lists...).
- and much more.

This advanced technique is enabled by the [Task 'Integrate with WebCenter'](#) on page 1758 in Automation Engine. It offers over 50 different commands to send to WebCenter.



**Note:** Automation Engine can also be told by an external system to send these commands to WebCenter. For more on this topic, see the chapter on **Integrating with External Systems**.

## 22.2. WebCenter Sites

Go to **Tools > Configure > WebCenter Sites** to configure links from Automation Engine to WebCenter sites.

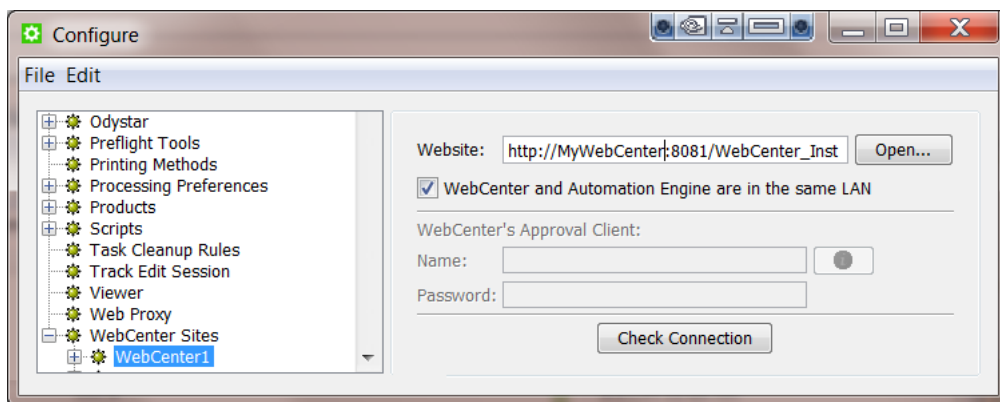

- **Website:**

Specify the web address of the WebCenter site. After you entered the WebCenter address, click **Open...** to check if the WebCenter site is up and running. If you are redirected to the login page, it means that the address is correct and that the site is up and running.



**Tip:** Be aware that this address is also the address that will be included in the notification e-mails when adding links to documents (approval cycle start E-mail). You should therefore make sure that the address can be accessed from the outside. Make sure to not use an internal address, but one that you want your (external) users to use when they use WebCenter.

- **WebCenter and Automation Engine are in the same LAN**

Select this toggle if this is true. This will most likely be the case. Deselect this toggle if WebCenter and Automation Engine are not in the same LAN.



**Note:** How can you verify if these two systems are in the same LAN? They are in the same LAN when you can connect from WebCenter's application server, this is the system where JBOSS is installed, to an Automation Engine Job Folder with the credentials of the **System Account** (by default the user BGSYSTEM or the one you changed it to, using [the System Account page in the Server Admin web page](#)).

- **WebCenter's Approval Client:**

If WebCenter and Automation Engine are not in the same LAN, you first need to create an Automation Engine **Approval Client** in WebCenter. This is necessary to give Automation Engine permissions to listen to the approval messages that are stored in WebCenter.



**Tip:** If the **Approval Client** does not exist yet, follow these steps:

1. In WebCenter, log in as **Administrator**.
2. Go to the **Admin** section. In **Configurations**, select **Workflow and Tunnel Approval Clients**.
3. Click the link **"New Workflow and Tunnel Approval Client"**.
4. Enter a **User name** and a **Password** for the Automation Engine client. Mind that this is also the user name and password that have to be entered when configuring the WebCenter site in Automation Engine.

Fill out the client **Name** and **Password** and click the **Check Connection** button. This will check if the user can log on successfully.



The **Info** button displays the following information: *"In case Automation Engine and WebCenter are not in the same local area network (LAN), the retrieval of the approval results is secured by a name and password. The name and password specified in Automation Engine must match the name and password specified in WebCenter by the WebCenter administrator. When clicking the 'Check' button, the WebCenter version will be checked and the name and password will be validated by WebCenter."*

- **Check Connection**

When you click this button, you should, after a few seconds, get a window saying **"Check OK"**. The software version of that WebCenter will also be mentioned.



**Note:** The button will check the validity of the user name or password to connect to that WebCenter but **not** of your WebCenter's **Approval Client**.

- 
**Note:** Passwords are encrypted.
- 
**Note:** When you connect to a secured WebCenter site (for example one that uses HTTPS://), then you have to export its security certificate and import it on the Automation Engine server. If this is not done, publishing from Automation Engine to WebCenter will result in an error. Learn more on how to do this in the chapter **Install SSL Certificates on the Workflow Production Server** of the [WebCenter documentation](#).
- 
**Tip:** After configuring a new WebCenter site, it is recommended to close your Pilot and start it again in order to see the updated list of WebCenter sites in your tickets.

## 22.3. The WebCenter View in Automation Engine Pilot

When a **Job** is selected in the Automation Engine **Pilot**, the **Views** category '**General**' offers a view named **WebCenter**.

This View shows you all documents in a WebCenter project related to this **Job** without having to open a browser to look at the project in WebCenter itself. The Pilot user can also see the documents' approval status in WebCenter and can also download those documents from this View.

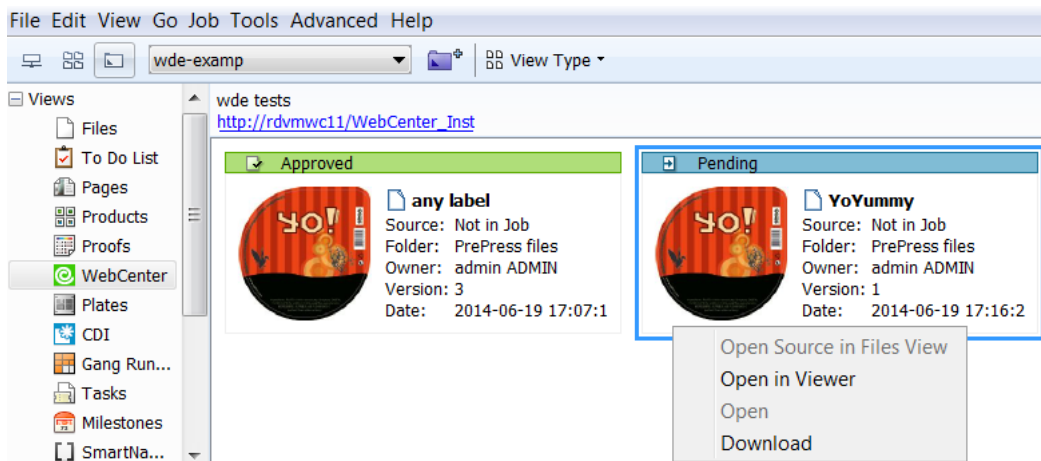

### How to set up

In the Pilot, in the list of Views, click on the WebCenter icon. If the WebCenter View is not configured yet, you will get a configuration page where you can fill out your WebCenter address and the user name/password that will be used to connect to WebCenter. If the WebCenter View is already configured, but you want to change the configuration, you can right-click in the window and you will get the configuration window again.

- 
**Tip:** In the configuration, you need to specify the Project name. It is common practice to map Jobs to WebCenter Projects using the SmartNames [Job Name] / [ Project Name]. On the configuration page, use the SmartName [Job Name] for the Project name.

### Troubleshooting

If you do not see anything appear in your WebCenter View, right-click on the **View** canvas and select **Configure**. Copy the value of the URL, open a browser window and go to this URL. You should get the WebCenter login window. To log in, use the same credentials as in the configure page. If you can log in with the user name of the configure page, retype the password in the configure page that you just used for logging in to WebCenter. This ensures that the password is still up-to-date. Try again to connect to WebCenter. If it still does not work, verify that the Project name you try to access really exists in WebCenter. Ensure that the SmartNames resolve correctly to the project in WebCenter.

## 22.4. WebCenter Integration Tasks

---

### 22.4.1. Task 'Create or Modify WebCenter Project'

#### Concept

This task allows to create a WebCenter Project from Automation Engine. If the project already exists, it will be updated with new or changed parameters.



**Tip:** Some users want a WebCenter Project for every new Job in Automation Engine.

- When you manually create a Job, you can (in the advanced tab) select this task to be launched when you create the Job.
- In a workflow, you can insert this task as a step after the **Create Job** task.

The WebCenter Project that you create is not limited to having the attributes that you defined here in this task. The Project can also get extra attributes from the selected Project Template or the Customer Company.

#### Requirements

To use this task successfully, you need

- **in Automation Engine:**
  - to be in a Job context, a Job with minimally an **Order ID**.
  - the user name and password of a WebCenter **Project Manager**.
- **in WebCenter:**
  - a **Project template** with **attributes matching the Automation Engine Job parameters (Order ID, SubOrder ID, and - if used - any custom parameter defined in the Parameters tab of the Job setup)**.



**Note:** Make sure the WebCenter attributes have the correct **type** for your Job parameter data. For example, when passing on a *date* parameter, the corresponding WebCenter attribute should have the type 'Date and Time'. When passing on a *numeric* value, the WebCenter attribute should have the type 'Numeric' ('Float' or 'Integer'). For more information about attributes, see the WebCenter documentation.



**Attention:** If the WebCenter attributes do not have the exact same name as the Automation Engine Job parameters, the Job parameters will not be passed on.

- Optionally, check the WebCenter naming of **Customer Company** and **Customer Location**.

### Task Options

Most fields allow both direct input and/or using SmartNames.

- **WebCenter Site:** Select one of the configured WebCenter sites. Optionally, click **Configure...** to access the Configure panel where those are set up. Learn more in [WebCenter Sites](#) on page 246.
- **Project:** The name of the WebCenter Project.
- **Project Template:** Define if you want the new Project to be based on a Project template.



**Note:** Make sure you select a Project template with attributes that match the Automation Engine Job parameters.

- **Project Status, Customer Company, Customer Location:** Click the refresh button to get an updated list.
- **Project Description:** If you want, define a description for this Project.
- **Project Manager User Name:** Define which WebCenter user will be the manager of this Project.





**Note:**

- This user must already exist in WebCenter.
- This *can* be the same user as the one you use to contact WebCenter with (the user and password fields further below). Also, that user that contacts WebCenter in this ticket must have **at least as much visibility** in WebCenter as the Project Manager user that you enter here.

- **Authentication:** Select the type:

- **User Name and Password:**

- **User Name:** The user that you contact WebCenter with and who will create or modify the Project.



**Note:** This user must be a Project Manager in WebCenter to be able to create Projects.

- **Password:**

- **Encrypted.** Type it in. It will not be shown visible.
- **Use SmartNames.** Some customers prefer a SmartName because they do not want Automation Engine users to know this password or because they want the latest changes in that password to be automatically picked up here.

- **Stored Password:**

Learn about the benefits of using stored passwords [here](#).

Select the stored **Password** that was created in the configure tool.

Click **Configure...** to open the configure tool from here.

### Modifying workflow parameters using this task

As mentioned in [Modifying Workflow Parameters During a Workflow](#) on page 870, this task can also be used to modify **Workflow Parameters**.

This task allows you to modify the value of a specific Workflow Parameter with the value of the Project ID of the created or modified WebCenter Project. The mapping of the Project ID to a specific Workflow Parameter can be done using the **Map Output Parameters** dialog.

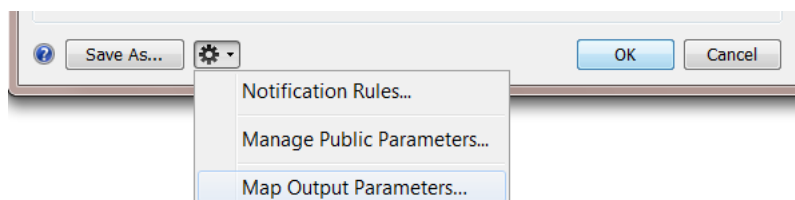

## 22.4.2. Task 'Publish on WebCenter'

### Concept

The **Publish on WebCenter** task allows to upload files from Automation Engine to a WebCenter Project.

Optionally, you can request WebCenter to start an approval cycle on those files. In that case, this **Publish on WebCenter** task will remain in a waiting status until WebCenter sends back the final answer of that cycle ('approved' or 'rejected').



**Note:** An approval cycle in WebCenter ends when all approval members have answered or when someone used a 'forced approve' or 'forced reject' answer.

### Also Metadata are published

When a PDF is uploaded to WebCenter, the task also uploads its metadata as an XML file.

When the PDF input file contains a link to an ARD cad file, this XML file will also inform WebCenter about the ARD file's name, position, rotation and mirroring. This then enables WebCenter to generate correct 3D images.

### Modifying workflow parameters using this task

As mentioned in [Modifying Workflow Parameters During a Workflow](#) on page 870, this task can also be used to modify **Workflow Parameters**.

This task allows you to modify the value of a specific Workflow Parameter with the value of the **Document Version ID** of the document you publish in WebCenter.

The mapping of the Document Version ID to a specific Workflow Parameter can be done using the **Map Output Parameters** Dialog. When you open this task ticket as part of a workflow, you will find it in the **Advanced** settings.

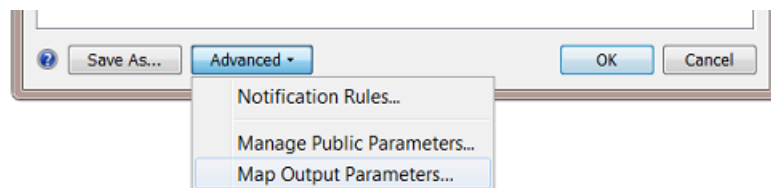

### Settings

This ticket has three tabs:

- **Destination:** Define in which WebCenter Project you want to publish the file.
- **Publish:** Define what version of the file you want to make public on WebCenter.
- **Approval:** Define if and how you want to start a WebCenter approval cycle.

### Destination

Destination Publish Approval

WebCenter Site: WebCenter1 Configure...

Project: [Job Name] [ ]

Folder: PrePress files [ ]

Project Template: [Job Customer Name]\_template [ ]

Document Name: [File] [ ]

Document Description: [ ]

Document Attributes:

Name ^	Value
[Bar code from XMP]	bar code
[Trim Box Height]	Vsize

Add Remove

---

Authentication: User Name and Password v

User Name: Elvis [ ]

Password:  Encrypted  Use SmartNames

.....



**Tip:** You can use SmartNames in most of the fields.

- **WebCenter Site:** Select the WebCenter site you want to publish the document to. Click **Configure...** if you want to add or change WebCenter sites. Learn more in [WebCenter Sites](#) on page 246.
- **Project:** Define in which WebCenter Project you want to publish the document.



**Tip:** Use [JobName] as Project name to map your Jobs in Automation Engine to the Projects in WebCenter.



**Important:** If the WebCenter Project does not yet exist at publish time, it will be created. Mind that the user that does the publish needs to be **Project Manager** in WebCenter to be able to create a Project in WebCenter.



**Remember:** The recommended method to create a WebCenter Project is by using the **Create or Modify WebCenter Project** task.



**Note:** When this task creates the Project, the Project manager will be:

- the Project Manager of the Template group if the WebCenter user executing the task is part of that group.
- or the WebCenter user executing this task.

- **Folder:** Define in which folder of that Project that the documents should be stored.



**Note:** If the folder does not exist yet, it will be created if the user is a **Project Manager** in WebCenter. With user we here mean the WebCenter user that you define further below in this ticket.

- **Project Template:** If the task needs to create the WebCenter Project, define here which existing Project template should be used.



**Note:** Some WebCenter users do not see all Project templates. Templates are filtered according to the user's visibility. When you define a user's visibility, you can list a set of companies and/or a set of groups. The effect on this is the following:

1. If a template has a customer defined, this customer (= company), needs to be in the list of companies that the user can see. If the company is not in the list of visible companies of this user, the template is not visible for this user. This means that this user can not use this template to create a new Project.
2. When the template has group members, WebCenter checks whether the user can see all the group members. As soon as there is one group in the template that is not visible to this the user, the template is considered as 'not visible' for this user. Again, the user will not be able to create a new project based on this template.

- **Document Name:** This field allows you to set a specific name of the published document. If left blank, it takes the original name of the document.



**Note:** If the document already exists, the task will create a new version of the document.



**Note:** If the document already exists in a different folder of that Project, the task will fail.

- **Document Description:** This will be the document's description in WebCenter.
- **Document Attributes:** This allows to set specific attributes for the document in WebCenter. These may have different names than what you call them in Automation Engine. For example you can map some metadata from the PDF to a Document Attribute.

- **Authentication:** Select the type:

- **User Name and Password:**

- **User Name:** The user that you contact WebCenter with and who will connect to WebCenter and upload the document.
- **Password:**
  - **Encrypted.** Type it in. It will not be shown visible.
  - **Use SmartNames.** Some customers prefer a SmartName because they do not want Automation Engine users to know this password or because they want the latest changes in that password to be automatically picked up here.

- **Stored Password:**

Learn about the benefits of using stored passwords [here](#).

Select the stored **Password** that was created in the configure tool.

Click **Configure...** to open the configure tool from here.



**Note:** The task will fail in error if this WebCenter user lacks upload rights, even if the Project exists.

## Publish

In this tab you decide what version of the input file you want to publish and/or if you want to prepare special view data for the WebCenter Viewer.

- [Allow Viewing and Annotating in WebCenter](#) on page 1751.
- [Allow Downloading in WebCenter](#) on page 1752.

### Allow Viewing and Annotating in WebCenter

- Select **Publish Annotations** when you also want to publish the XFDF files that were created by the *Inspection tasks*. Learn more in [Inspection Results as Annotations in Viewers](#) on page 1159.
- Select **Prepare for viewing and annotating** to have the graphic files prepared into raster data for the (WebCenter) **Viewer**. These rasterized data will then also be published to WebCenter.



**Note:** The graphics kernel that is used to prepare the files for the Viewer follows the settings that were chosen in the Configure tool **Viewer - View \* Files As in \***. Since AE v20, the default setting is to view PDF files 'As in ArtPro+'. Since AE v23, the default is the 'As in ArtPro+ (latest technology)'.



**Note:** This option can not be selected on when WebCenter and Automation Engine are not in the same LAN.



**Note:** When this option is not selected, WebCenter itself will then need to create this raster data for viewing.

- The **Resolution for non-images** (linework, text, ...) will be the maximum resolution you will have in the WebCenter Viewer. You can choose between:
  - **Optimal:** The best resolution is used, mainly based on the size of the file. It is **recommended** to select this option. For small files, it will rasterize with a high resolution. For large files, it will be a lower resolution. This balance is to ensure you always have a fast viewing experience in the Viewer, both when you first open the file and when you start zooming in.
  - **Custom:** Allows you to specify a resolution yourself. When you set a high resolution, it will create large rasterized files. Set a low resolution for a lower quality view of the document in the WebCenter Viewer.



**Important:** For images, the maximum available resolution is used.

- **Anti-aliasing:** This is relevant for the linework objects that need pre-processing and for which extra images are generated (CTs). Anti-aliasing smooth-ens the staircase effect you get in these CTs. Text will be more readable, also when zooming in.
- **Automatic grouping of input file into digital film sets:** In a workflow, the publish task can be used right after a RIP task that creates digital films (for example LEN or TIFF files). In such cases, you may want to publish these files as one document. Enable this option to bundle that set of digital film files and publish them as one document to WebCenter. Each digital film will make up one separation of the document.



**Note:** When digital film files were rasterized as one group, the Viewer tool will also recognize them as 1 set of separations.

### Allow Downloading in WebCenter

#### Make available for download:

- When this option is **off**, the **Publish on WebCenter** task will not publish the task's input file to WebCenter but only the 'prepared' rasterized files. Choose this option when you do not want any form of your production files to be downloaded by WebCenter users.
- When this option is **on**, you can choose which files you will make available for download on WebCenter (if the user has such permissions):
- **Input files.** For example: your task input file is a production PDF, and that is the PDF you want the WebCenter users to have access to. Or you already had made low resolution PDFs, and you choose to publish those instead.
- **PDF files for proofing.** In this case, you choose not to publish the input file but a **PDF file for proofing** that does not exist yet. Select from the list of PDF export tickets which kind of PDF you wish to create and then publish to the WebCenter user. This way, you offer the outside world a 'PDF proxy' file instead of your real input production file.



**Attention:** Always choose this option when the task input files are not self-contained. For example when your PDF refers to artwork, fonts or other PDFs.



**Note:** If you select **PDF files for proofing** the viewing quality will be limited to the resolution of the PDF files for viewing.

When disabling both **Prepare for viewing and annotating** and **Make available for download**, a warning box is displayed indicating that no data will be published. You need to select at least one type of data to publish.

### Approval

The Approval tab allows you to select if and when an approval cycle should be started on WebCenter.



**Important:** Make sure you already have an approval cycle set up in WebCenter! This approval cycle setup will indicate who to invite, what their role is and more. Mind that the approval cycle can be part of a Project template that you here selected.

The screenshot shows the 'Approval' tab of a configuration window. At the top, there are three tabs: 'Destination', 'Publish', and 'Approval'. The 'Approval' tab is active. Below the tabs, there are two checked checkboxes: 'Start the approval cycle and wait for approval' and 'Due date: Tomorrow at 5:00 PM'. Below these, there is an 'Annotations:' label followed by a text input field containing the placeholder '[File URL]/[File].html' and a 'Browse' button with a folder icon.

- **Start the Approval Cycle and wait for approval.** Select this if you want the approval cycle to start automatically as soon as the file is uploaded to WebCenter. For this, you need to have an approval rule specified in the Project or Project folder where you upload the document to. By default, WebCenter will apply the folder approval setup if it exists. If not, the Project approval setup will be applied.
- **Due Date:** If the WebCenter user that you use to log in with ('Destination' tab) has the **Change Approval Setup** permission in WebCenter, you can also set the approval due date.



**Note:** The due date specified here will take priority over the due date specified in WebCenter.

You can choose one of the following:

Choice	Explanation
<b>Immediate</b>	This will set the due date to the time that the task was launched.
<b>Today</b>	This will set the due date to today, at a user specified time.
<b>Tomorrow</b>	This will set the due date to tomorrow at a user specified time.
<b>In ... hours</b>	This will set the due date to a specified number hours from the time the task was launched.
<b>In ... days</b>	This will set the due date to a specified number of days from the time the task was launched and at a specified time. A SmartName can be used to set the number of days.  For example "in 2 days at 5:43 PM" is the same as "the day after tomorrow at 5:43 PM".
<b>On</b>	Use the calendar to set the due date and time.
<b>Job due date</b>	This will set the due date to the one specified in the Job setup.
<b>Select SmartName...</b>	If you use a SmartName, it will also be added to the above menu items.  <div data-bbox="879 1234 941 1296" data-label="Image"> </div> <div data-bbox="959 1234 1425 1379" data-label="Text"> <p><b>Note:</b> The SmartName should be conform to the ISO 8601 date string format. For example 2014-12-27T11:30:00+02:00</p> </div>

- Annotations:**

If any annotations were made during the WebCenter approval cycle, the **Publish on WebCenter** task generates a annotations summary. At the end of the approval cycle, an HTML file will be generated. This HTML file redirects the Automation Engine user directly to the WebCenter annotations page in a browser. He will be asked to login to WebCenter.

You can here decide the folder and name where this 'shortcut' HTML will be written.

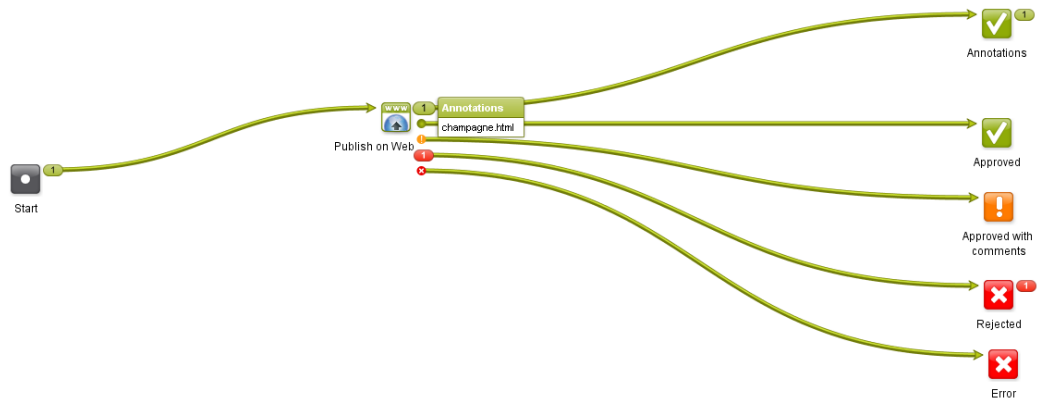

### What if you get conditional approvals?

Documents that are approved conditionally in WebCenter will go through the **Approved with a Condition** output of the **Publish on Web** task (standard of the type 'warning').



It is good practice to use a **Wait for Action (Checkpoint)** task for those documents, so the Automation Engine operator can fix them manually. For more details about conditional approval, see the WebCenter documentation.

### What if you have multiple input files?

When your **Publish on WebCenter** task has multiple input files, and your ticket requests an approval cycle, then an approval cycle will be started for each of those input files. When the **Publish on WebCenter** task has received an answer for all files, it will then show their specific status in the task's output pins: which one was approved or rejected, etc.

When you use the **Split** task in front of the **Publish on WebCenter** task, then Automation Engine will start up a Publish task **per** input file.

### Troubleshooting tip

If you get errors in this publish task and the log file does not give you an indication on what went wrong, then try to do the same steps interactively inside WebCenter, using the user account that you had used in your Publish ticket. If the error is due to permissions, you will quickly figure out what goes wrong.



## Publishing Automation Engine Products to WebCenter



**Attention:** This page addresses customers who use the Automation Engine **Products** tool. Learn more about this tool in the chapter [Products](#) on page 594.

When you publish an Automation Engine **Product** to WebCenter, the Product Properties and **Product (Part) Parameters** will be taken as **WebCenter Attributes**. If there are existing WebCenter attributes with corresponding names, their values will be updated during publishing.



**Attention:** For this to work, WebCenter needs to be enabled to work with **BOM - Bill Of Materials**. This is a setting in WebCenter -> Admin -> General Preferences.

The following Product (Part) properties and Product (Part) Parameters are synchronized with WebCenter Attributes (see further how to rename these internal names to more readable ones):

Automation Engine Properties/Parameter	WebCenter Attribute (Internal name)
Product Customer Reference	ae.p.cusref
Product Custom Field 1	ae.p.category1
Product Custom Field 2	ae.p.category2
Product Custom Field 3	ae.p.category3
Product Internal ID	ae.p.id
Product ID	ae.p.prodid
Product Name	ae.p.name
Product Description	ae.p.desc
Product Part Internal ID	ae.ppid
Part Default Angle	ae.pp.defaultangle
Part Default Dotshape	ae.pp.defaultdotshape
Part URL	ae.pp.url
Part Default Ruling	ae.pp.defaultruling
Part Preferred InkBook	ae.pp.preferredinkbook
Part Preferred InkBook UI	ae.pp.preferredinkbookui
Part Internal ID	ae.pp.id
Part Custom Field 3	ae.pp.category3
Part Custom Field 2	ae.pp.category2
Part File	ae.pp.file
Part Status	ae.pp.status
Part Status Nickname	ae.pp.status_nickname
Part Status User	ae.pp.status_user
Part Status Notes	ae.pp.status_notes
Part Status Date	ae.pp.status_date

Automation Engine Properties/Parameter	WebCenter Attribute (Internal name)
Part Folder	ae.pp.folder
Part Custom Field 1	ae.pp.category1
Part Name	ae.pp.name
Part Inks	ae.pp.inks
Part Barcodes	ae.pp.barcodes
Product Customer Name	ae.c.name
Product Customer Description	ae.c.desc
Product Customer ID	ae.c.id
MyProductParameter1	ae.p.par.MyProductParameter1
MyProductPartParameter2	ae.pp.par.MyProductPartParameter1

When a **Product** or **Product Part** is published, the corresponding WebCenter Documents are automatically added to the **Bill Of Materials** of the WebCenter Project. The **Product Amount** for the Job (if given) is updated as the **Count** property of the **Bill of Materials**.



**Tip:** You can rename the internal name of WebCenter Attributes to a more readable name by first adding it to a **Category**:

The screenshot shows the 'Edit Category AETestCategory' interface. On the left, there is a list of attributes including '\$dl\$Dieline', '\$dl\$DocumentLink1', '\$dl\$DocumentLinkRich', '\$dl\$Material', '\$dl\$POA', '\$dl\$Search', '\*tema\_Rich\_Text', '00 Change Category', '00 Change Order Number', '00 Change Type', and '00 Description'. The central area displays a grid layout with a header bar containing 'ae.p.name', 'ae.c.desc', and 'ae.p.prodId'. On the right, the 'Details for selected cell' panel shows the attribute 'ae.p.name' with a 'Text' type and a 'Label' of 'Product Name'. Red arrows indicate the mapping from the 'Internal name' (ae.p.name) to the 'Nicer name' (Product Name).

Learn more about this in the PDF named **Connection between Automation Engine and WebCenter 14** that you can download from <https://www.esko.com/en/support/product?id=WebCenter>.

### 22.4.3. Task 'Download WebCenter Document'

This task allows to download documents from WebCenter into an Automation Engine Container (or Job Folder). Optionally, downloaded documents including their document attributes can be immediately added to the Products database.

The following **SmartNames** are useful in a **Download WebCenter Document** task:

- **WebCenter Document Folder:** The folder in the WebCenter project that holds the document that you are downloading.
- **WebCenter Document Name:** The name of the WebCenter document that you are downloading.
- **WebCenter Document Original File name:** The original name of the file that was uploaded to WebCenter and there made a document.

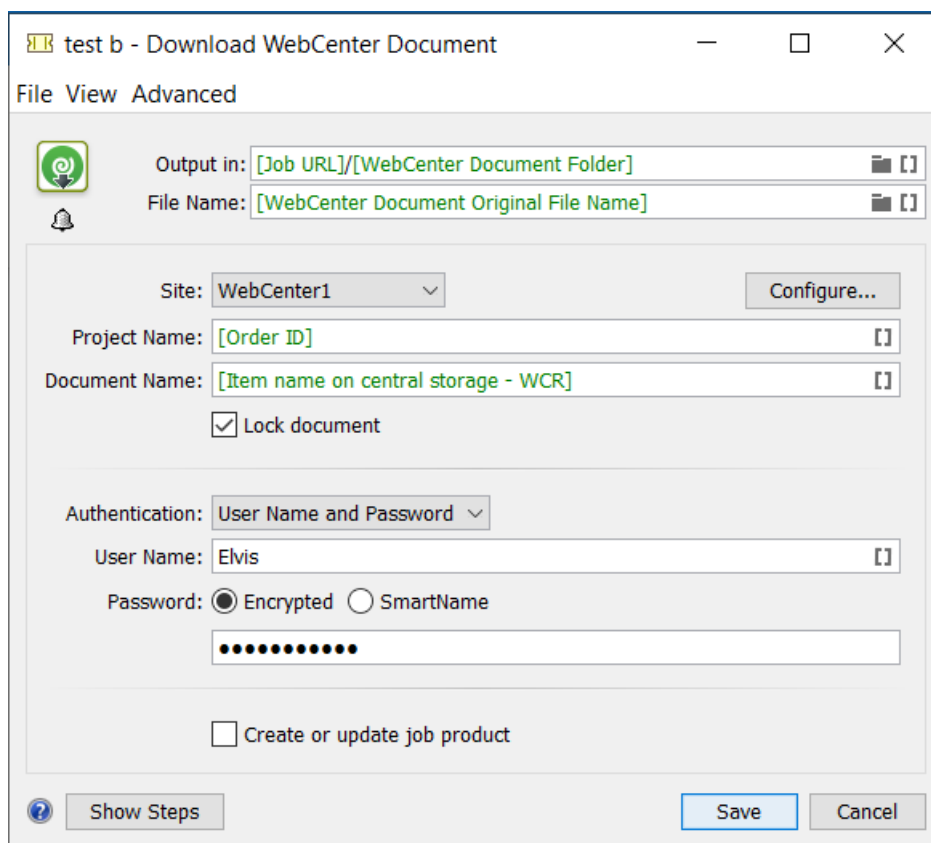

- **Output in and File name** The above screen-shot shows how the default ticket proposes you a logic place and name for the file you are downloading.
- **Site:** The WebCenter site to download the document from. Click **Configure...** to add or change WebCenter site configurations (enabled only for administrator users). Learn more in [WebCenter Sites](#) on page 246.
- **Project Name:** The name of the WebCenter Project that you want to download a document from.
- **Document Name:** The name of the WebCenter document that you want to download.
- **Lock document:** Select this option if you want to lock the document in WebCenter. When the document is locked, other WebCenter users will not be allowed to upload new versions. Only the WebCenter user that locked the document can publish a new version and/or unlock the document.
- **Authentication:** Select the type:
  - **User Name and Password:**
    - **User Name:** The user that you contact WebCenter with and who will that download and/or lock the document.
    - **Password:**

- **Encrypted.** Type it in. It will not be shown visible.
- **Use SmartNames.** Some customers prefer a SmartName because they do not want Automation Engine users to know this password or because they want the latest changes in that password to be automatically picked up here.
- **Stored Password:**  
 Learn about the benefits of using stored passwords [here](#).  
 Select the stored **Password** that was created in the configure tool.  
 Click **Configure...** to open the configure tool from here.
- **Create or update Job Product:** Select this option if you want to add the downloaded document as an Automation Engine Product for the Job you are working in. If the file is already a Product, the WebCenter document attributes are merged with the existing Product (Part) parameters. If the attribute already exists as Product (Part) parameter, that Product (Part) parameter's value is *updated*. If the attribute was not a Product (Part) parameter yet, it is *added* as a Product parameter.



**Important:** In order to use the option **Create or update Job Product**, the task must run in a Job context!

## 22.5. Advanced WebCenter Integration

---

### 22.5.1. Task 'Integrate with WebCenter'

#### Concept

WebCenter can be used

- interactively, in a browser, by a WebCenter user
- by an external system, through a special connection setup
- by Automation Engine, by using the **Integrate with WebCenter** task.

This Automation Engine task goes a lot further than the ones we documented earlier that only focus on exchanging files and creating projects in WebCenter. This **Integrate with WebCenter** task enables Automation Engine to perform more than 50 different types of actions on WebCenter. Some of these actions are very elaborate commands or requests for information and some even change configurations.



**Note:** The technology behind this task has historically often been referred to as the "WebCenter SDK"



**Attention:** This task requires advanced knowledge of both WebCenter and Automation Engine.

#### Task Options

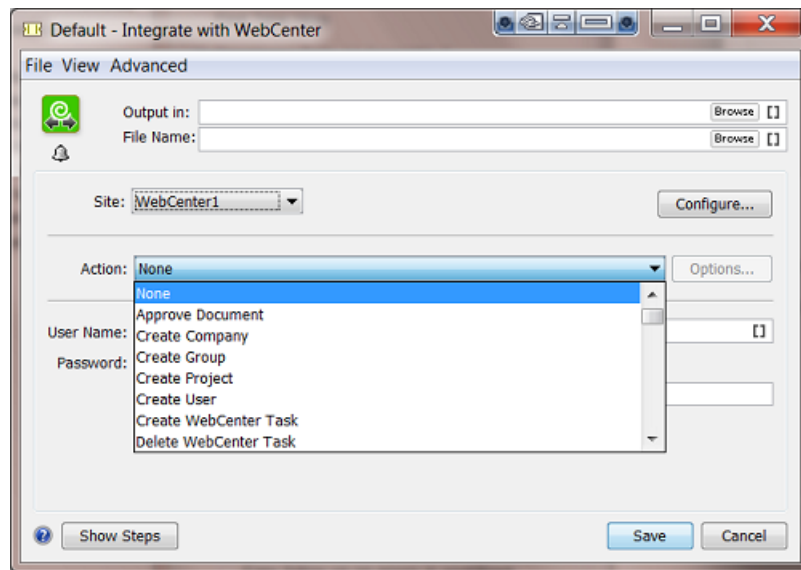

- **Output in** and **File name**: Depending on the **Action** chosen below, these fields might be relevant or not. If the action triggers this task to have an output file, then you can here define their folder and name.
- **Site**: Select the WebCenter site from the list. Click **Configure...** to add or change WebCenter site configurations (enabled only for administrator users). Learn more in '[WebCenter Sites](#) on page 246'.



**Note:** A connection will be made with the WebCenter that you select. It will not just test the connection but will also get the list of possible commands from that specific WebCenter server. That list then becomes the list of **Actions** (for this WebCenter).

- **Action**: Select the action. When the selected action offers options, the **Options...** button will become active. The options dialog is specific per action. Here is an example:

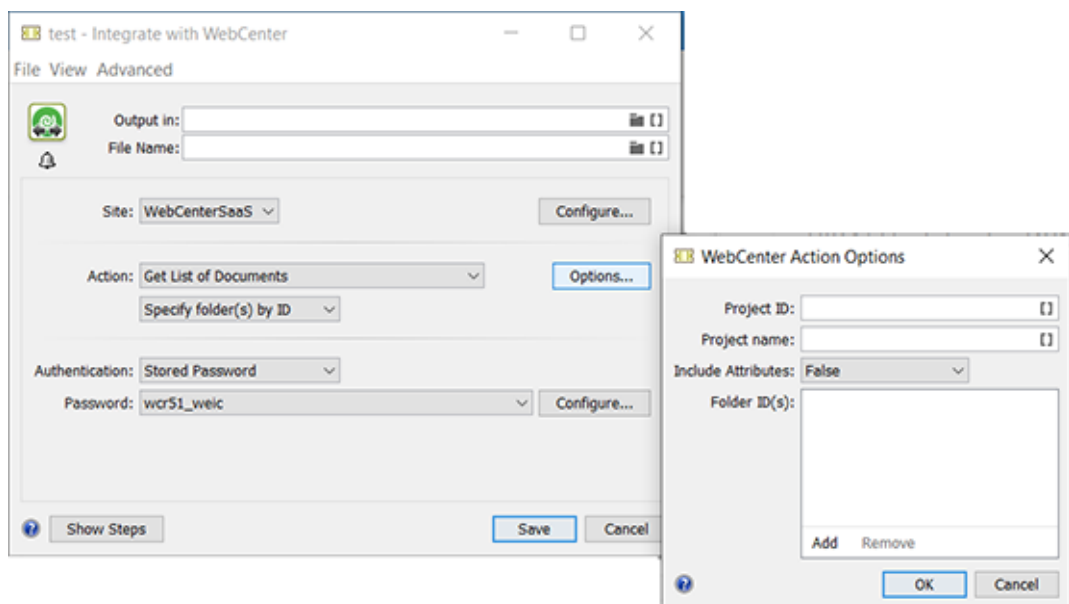

See how selecting the action "Get List of Documents" automatically offers a sub-type of action to choose, here "Specify folder(s) by ID" (or "by Name"). The button **Options...** offers another specific dialog with more options for this Action.



**Attention:** Most option fields offer **Tool Tips** which extra information, conditions and general tips. Tool tips appear when you hold your mouse-cursor over the field.

- **Authentication:** Select the type:
  - **User Name and Password:**
    - **User Name:** The user that you contact WebCenter with and who will execute the selected action on WebCenter. Make sure this user has the required privileges.
    - **Password:**
      - **Encrypted.** Type it in. It will not be shown visible.
      - **Use SmartNames.** Some customers prefer a SmartName because they do not want Automation Engine users to know this password or because they want the latest changes in that password to be automatically picked up here.
  - **Stored Password:**

Learn about the benefits of using stored passwords [here](#).

Select the stored **Password** that was created in the configure tool.

Click **Configure...** to open the configure tool from here.

**More info**

More detailed technical info is available in the "**WebCenter SDK documentation**". Learn more about this document in this Esko Knowledge Base article: [KB 92180925](#).

**Modifying workflow parameters using this task**

As mentioned in [Modifying Workflow Parameters During a Workflow](#) on page 870, this task can also be used to modify **Workflow Parameters**.

The **Integrate with WebCenter** task allows you to modify the value of a specific Workflow Parameter with the result of the action executed by the task.

For example (as shown in below screen shot): When you select the action "**Get Document History**", you can update the value of a specific Workflow Parameter with the value of the approval status of the document. First you need to define to which Workflow Parameter a specific Output Parameter needs to be mapped to. You can do this using the Map Output Parameters Dialog.

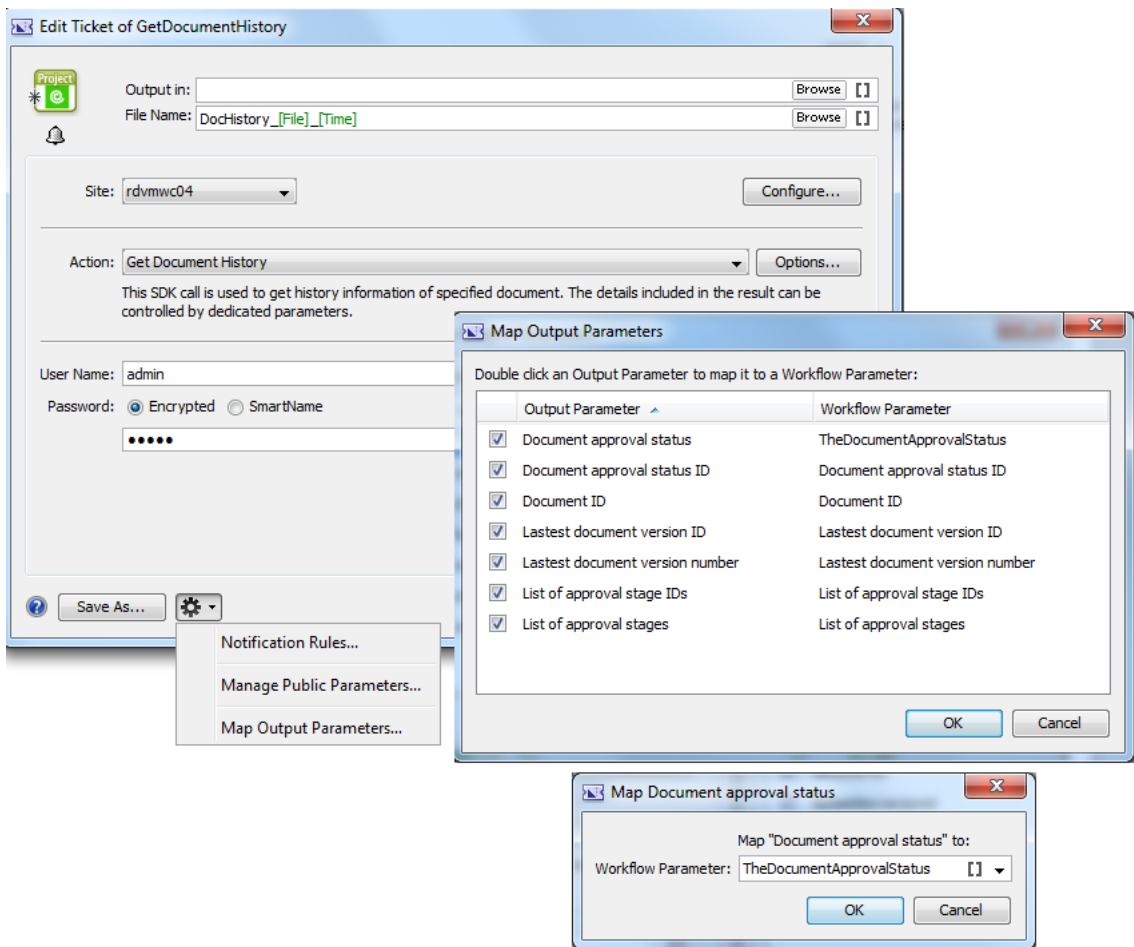

## 23. Integrating with Share & Approve

### 23.1. What is Share & Approve?

**Share & Approve** is a web-based approval tool from Esko. It is available in a *SaaS model*. It is based on Esko Cloud architecture. Learn more on <https://www.esko.com/en/products/share-approve>.

Several dedicated Automation Engine tasks enable the communication with Share & Approve. A workflow typically publishes files to S&A, including a request for their approval, then wait until decision is made and then report this back to Automation Engine.

Setting up the connection from your Automation Engine to a Share & Approve site is explained in the 'Share & Approve Getting Started' guide. That PDF and more can be found on the documentation site for Share & Approve: <https://www.esko.com/en/Support/Product?id=Share%20and%20Approve>.

### 23.2. Task 'Upload Files to Share & Approve'

#### Concept

This task uploads the selected files to a specific folder on your Share & Approve site. You can upload any file that resides on an Automation Engine Container.

This task will not upload folders.

This task will not start an approval cycle.

#### Settings

- **Site:** Select one of the sites from the list. These are the sites that your Esko Cloud account (token) allows to access. Their name is shown as <organization-ID>/<Site-Name>. Click **Configure...** to manage or see them in more detail.



**Attention:** In this ticket, we strongly advise to only select a site that was set up to serve as approval tool. Do NOT select a site that was set up to enable an *AE collaboration workflow!*



- **Upload to:** Specify the folder to upload to. The path is relative to the root of the selected site. Subfolders are created on Share & Approve as needed.

When a file was already uploaded, a new version is created on Share & Approve.



**Note:** This field needs to be *URL encoded*.



**Note:** This field is case-sensitive! So be extra careful when typing in a path.



**Attention:** When selecting files that are not in an active job folder, then do not use SmartNames that require a job context, like [Job Customer ID].



**Note:** Also very large files can be uploaded. For example > 1 Gb.



**Note:** When used in a workflow ticket, see how an *empty token* is put on the output-pin 'OK'. No other local file was generated. The output pin '**Uploaded**' links back to the local input file (when it was successfully uploaded). This makes it possible to extend the workflow on that file after that step.

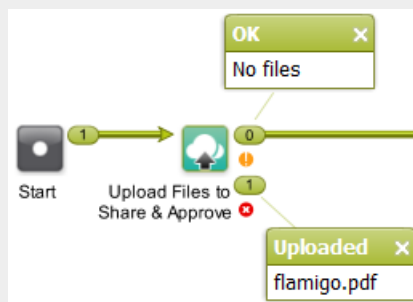

- **Insert Esko Cloud link into local file:** Select this to add a link into the PDF's metadata that enables an integration between ArtPro+, Share & Approve and the AE Viewer.



**Warning:** After this link was added to its metadata, the file will have a new modification date.

When this link is inserted, these extras become possible:

- **In the AE Viewer**, annotations made on this file in Share & Approve (or ArtPro+) will be shown there as well (only when using 'As in ArtPro+, latest technology').
- **In its Info panel/page**, also this metadata will be shown. The General tab now indicates its presence with a link to **View on Esko Cloud**. It functions as a hyperlink to view that file on Esko Cloud (i.e. the Share & Approve site it was uploaded to).

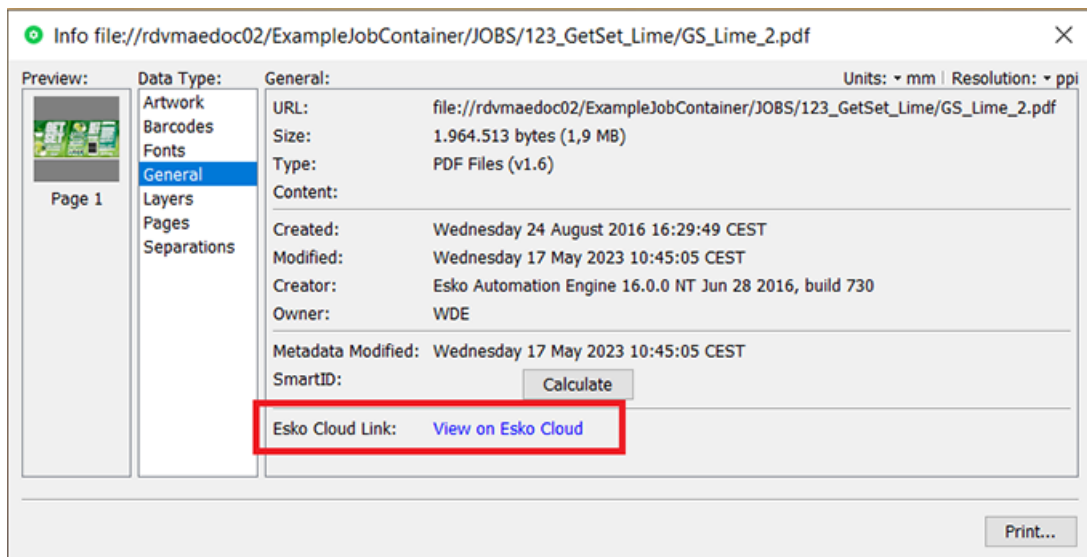

- In ArtPro+, after connecting with Share & Approve, the editor is now also aware of the file's approval status on Share & Approve and also shows the (saved) annotations on Share & Approve. In ArtPro+, these annotations can also be edited and will be synchronized back up to Share & Approve. Learn more about this integration between ArtPro+ and Share & Approve in the [user guide of ArtPro+](#).

## 23.3. Task 'Start Approval Cycle on Share & Approve'

### Concept

This task starts an approval cycle on Share & Approve. The task ends when the approval cycle has been started.

If you want a workflow to wait until the approval cycle has ended, then have this task followed by the task [Wait For Approval Cycle on Share & Approve](#).

In a workflow ticket, the input for this task needs to come from any of these tasks:

- [Upload Files to Esko Cloud Job Folder](#) (workflow *token*)
- [Select Files on Esko Cloud Job Folder](#) (.json file)
- [Upload Files to Share & Approve](#) (workflow *token*)



**Attention:** Make sure that the local files for which you started an approval cycle are not changed during the that approval cycle.



**Attention:** An approval cycle that ends in rejecting the file has no further influence in Automation Engine. You could for example still output or expose that file.

When you upload a new version of a file while its approval cycle is still ongoing, then the first cycle will be stopped immediately and a new one will be started.

### Settings

- **Approval type:**

- **Folder approval:**

The approval cycle is started conform the approval setup for the folder in Share & Approve where the files reside, or the setup that that folder inherits it from a parent folder.



**Note:** When you use a SmartName to choose this type of approval, it should resolve to 'folder'.



**Note:** The task will fail when no approval cycle was set up for that folder.

- **By E-mail:**

- **Approver:** A comma separated list of E-mail addresses.

- When the E-mail address corresponds to a **registered user** in the Share & Approve site, then the E-mail provides a link to sign in to the Share & Approve site with his Share & Approve credentials.

Registered users are invited to the approval cycle with the role '**Approver**'.

- When the E-mail address does not correspond to a registered user in the Share & Approve site, then the E-mail will provide a direct link that opens the file in the Viewer tool of Share & Approve. The user will not be asked to sign in. They can decide the File's status in this Viewer. They have no access to any other pages of the Share & Approve UI.

This type of user is also referred to as a 'Shared Link User'. The link that these unregistered users get to that file on Share & Approve is temporary. Technically, such a link is also known as an 'unguessable' link.

Unregistered users are invited to the approval cycle with the role '**Reviewer**'.



**Note:** When using a SmartName to choose this type, it should resolve to 'email'.

- **Language:** Select the language that should be used in the e-mails to unregistered users of S&A.

When using a SmartName, it must resolve to the short language code, for example `fr`, `de`, `jp`, `nl` . etc.



**Note:** This requires that, on the S&A site, "Enable Localization" is selected.



**Note:** Before AE 22.03, you could already set this language by adding it behind the e-mail address and behind a vertical bar. For example: " `lola@bestbrand.com|sp`".

Be aware that defining a language by means of that e-mail - suffix will overrule any choice you may have selected here in this list.



**Note:** This is for unregistered S&A users. Registered S&A users can just change language setting in their own S&A preferences.

- **Approval Master:** This is the S&A user that can force approve or force reject an approval cycle. In both above mentioned approval types, the approval master can be set or overruled by the here specified (single) e-mail address. Select a user from the list or use a SmartName.

- This approval master must already exist as a registered user on S&A. If that is not the case, the approval master will not be set and a warning will describe this in the log file. The task does not fail.
- Leaving this field empty makes the task fall back on the approval master defined in the document approval setting or the folder approval setting on S&A (by default this is the AE "Equipment" name).
- **Due Date:** Specify a time when the approval cycle must have ended.

When this due date has been reached, and the approval cycle is not yet finished, then Share & Approve sends out an overdue notification. Also, in the UI of Share & Approve, the due date is shown in red.



**Note:** A due date specified by a SmartName must resolve to a valid ISO 8601 string, i.e. the format `yyyy-mm-ddThh:mm:ss`. For example `2017-03-10T10:00:00`.

## 23.4. Task 'Wait for Approval on Share & Approve'

This task waits until the Share & Approve approval cycle of each input file has ended.

The task ends when all related approval cycles have ended. Due dates have no influence here.

When the task ends, a report .json file is put on the 'OK' output pin (one report per approval cycle). Typically, this file is interpreted by the next step '[Route Approval Cycle](#)'.

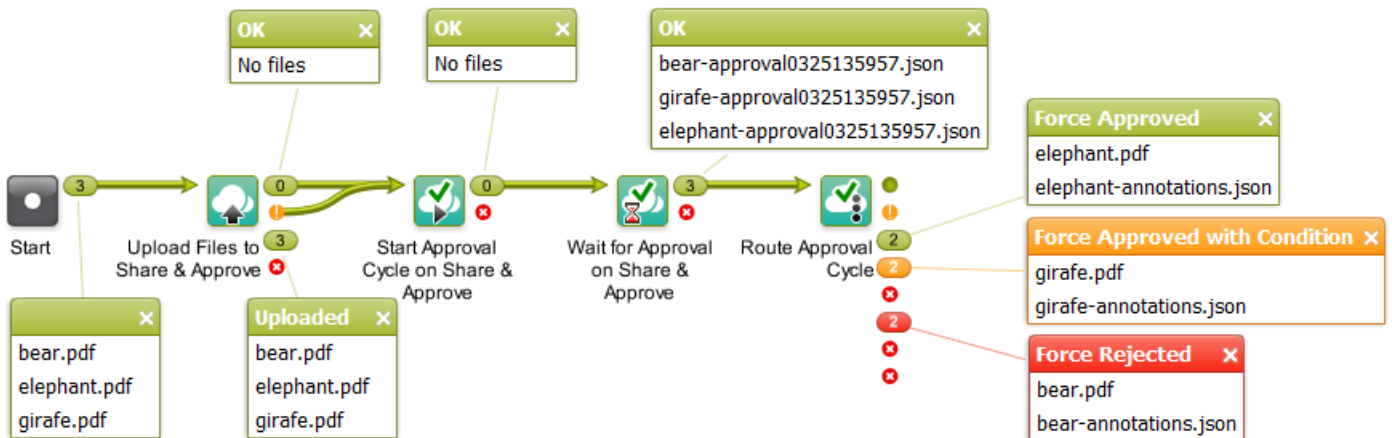

**Note:** Canceling this task does not stop the approval cycle. It just means that you give up waiting.

The task ticket offers no settings.

## 23.5. Task 'Remove Esko Cloud Link'

This task removes the link from the input file's metadata that was added by the task [Upload files to Share & Approve](#). This file can be a native or normalized PDF.

This can be used when

- You made a mistake to upload that file to S&A (and include a link). Removing it from S&A alone will not remove the link in the local file's metadata.
- You use a same file as base for a new variant design and you want to remove all traces of a prior approval cycle.

As the file's metadata is changed (again), the file also gets a new modification date.

The task ends in warning when the file does not contain such a link.

## 23.6. Routing an Approval Cycle

In a workflow, this task allows to take appropriate actions depending on the end state of the approval cycle.

Typically, this step is preceded by the step [Wait for Approval on Share & Approve](#).

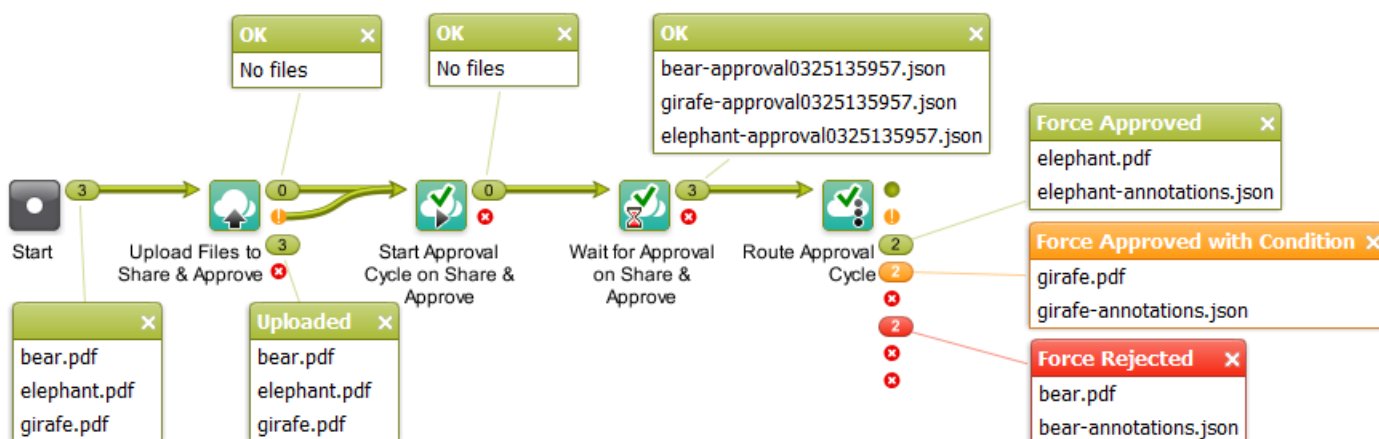

The output pin shows both the input PDF (the local one) and the .json file containing the comments.

The default output pins are

- **Approved**
- **Approved with Condition**
- **Force Approved**
- **Force Approved with Condition**
- **Rejected**
- **Force Rejected**
- **Unexpected**

- **Error**

The task ticket offers no settings.

Learn more about approval states in the documentation of [Share & Approve](#).

## 23.7. FAQs

---

### Can I use Share & Approve tasks in combination with AE Job Sharing tasks?

Yes you can.

You can for example make a workflow that selects or uploads files to an Esko Cloud Job Folder and then starts an approval cycle on them.



# 24. Integrating with External Systems

---

## 24.1. Introduction

---

This chapter is a guide for those who want to connect their Automation Engine server with other systems. Typically these systems are

- Business Systems like MIS (Management Information System) or ERP (Enterprise Resource Planning). These systems usually have components like order entry, price calculation, customer database, production planning, stock etc.. These systems can be purchased by your company from an MIS vendor and then adapted to your specific business process or your company could have created her own unique system.
- Asset Management systems. They focus on managing and sharing your prepress data and are usually web-enabled.

A connection between your Automation Engine server and (one of) these systems is of course digital and can be one-directional, bi-directional or, in case more than 2 systems are connected, even triangular.



**Note:** Throughout this document, for the sake of simplification, we will name such systems 'the external system'.



**Note:** Many features that we describe in this chapter require the optional module named **Automation Engine Connect**.



**Note:** A separate chapter is available on [Integrating Automation Engine with Esko WebCenter](#).

### 24.1.1. Why Integrate?

#### **Faster.**

No time is wasted by waiting, usually for a person.

#### **Better.**

Error reduction: no errors re-typing or misinterpreting. A small error can have huge costs. A wrong 'status' interpretation can have major production (cost) consequences.

#### **More consistent, more process control.**

Having a consistent way of working will benefit all. It is easier to train new people. It will be required when your company is trying to receive quality certifications (ISO etc..).

#### **Operators in both departments can focus on more added value tasks.**

The freed up time can now be used to increase the *quality* of what they do or to *think* their actions over. Hiring new (young) people will be easier when they see you have modern ways of working.

Now let's have a look at what information typically is exchanged in each direction.

### 24.1.2. External System sending commands To Automation Engine

#### **Create an Automation Engine Job and set Job parameters.**

An Automation Engine Job represents a job order that you get from the business system. So it is logical not to create those Automation Engine Jobs manually but to get your instructions from that system in an automated digital way. All the parameters should then be picked up in a highly automated workflow.

#### **Create an Automation Engine Product and set Product parameters.**

New design data that arrive can be automatically added to the Automation Engine Products database, including the detailed product specifications like barcode and inks. Often, these design data arrive before there is a job order to produce them. The workflow can link this newly created product to a Job.

#### **Start an Automation Engine workflow with parameters defined by the external system.**

Not all parameters need to be stored first in a Job or Product: Automation Engine can also retrieve parameters from an external system during a workflow and use these parameters in subsequent steps of the workflow.

### 24.1.3. Automation Engine sending commands To an External System

#### **Setting Job or Product status in that external system.**

The business system is very interested in what is happening with the job in the prepress department. Being automatically informed on the exact status can have major benefits: Your sales/service people will have up to date info for your customer. Your production will be more efficient when its planning is based on reality. Automation Engine can send such feedback automatically. And based on that new status, the external system may also decide to start an own automatic workflow.

#### **Initiating actions on that external system.**

Automation Engine could even do more than that. It could really talk to that external application, ask questions and come back with a set of information.

### 24.1.4. Some general advice

#### **Have a project manager**

Appoint someone who owns the mission to do this. This integration can affect many people so someone needs to be in charge. It is actually possible that it is the first time that these 2 different departments (sales-service and prepress) are part of a same project. Each department will defend its way of working. Each department will not know all complexities of 'the other side'.

#### **Change Management**

When you start eliminating some human intervention, it is possible that new questions will come to the surface. Any changes in the way you work in such a busy production environment will need to be defended. The integration is indeed technical but it is actually *not* 'just an IT project': the reason you do this will be of interest to higher management. Often higher management is where such ideas to integrate start. Making some changes will be necessary to get that higher efficiency that they are looking for.



### Step by Step

Start with a step that is 'obvious' and build from there. Before 'going live', carefully test and dare to consider all sides of the changes that this integration will cause. Using *both* the new *and* the old workflow can be confusing, so be prepared to switch over fast.

## 24.1.5. Need any help?

If you want help with your integration project, Esko offers 2 levels of service.

- Standard training by an Esko Academy trainer.

Esko trainers will explain the Esko part of the tools.



**Tip:** After learning about the concepts and features in this documentation, we advise to also check the chapter [Examples](#) on page 1858.

- Help from an Esko Solution Architect.

Esko Solution Architects are experienced in such system integrations and have a broader knowledge of 'workflow', beyond the world of Esko products. Contact your Esko sales rep if you want to know more.

## 24.1.6. What about JDF?



**Note:** Job Definition Format is a standard language based on XML. It was created by the CIP4 group to help standardize system integration in the printing industry. Learn more on <http://www.cip4.org>.

Integrations that use JDF/JMF require assistance from an Esko Solution Architect. That is why this documentation does not cover JDF/JMF.



**Note:** With some specific MIS, Esko optionally offers a 'standard' integration package based on a White Paper. Contact your sales contact if you want to know more.

## 24.2. Integration Concepts

---

Let's distinguish the main *concepts* in integrating with Automation Engine. In many integrations, several of these concepts are combined. There is no pre-defined order in which these concepts would be used in your particular case.

The tools that we here introduce are documented in detail in the next chapters.

### 24.2.1. AE Access Points Triggering a Workflow on Automation Engine

Access Points trigger a workflow after they detected a signal from 'outside'. They use a 'polling' mechanism: they check at a regular time interval if they have to trigger that workflow. There are many types of Access Points and you can create as many as you need.

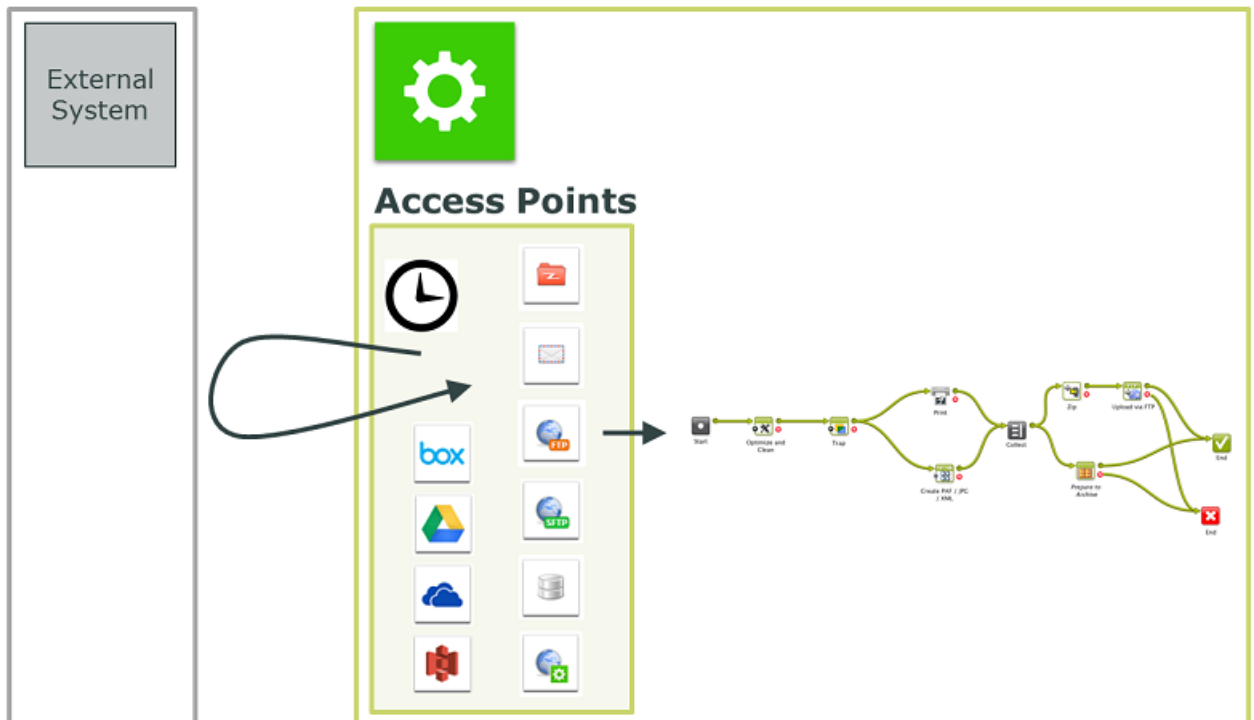

A typical example is a classic hot folder (a **Folder Access Point**), where the incoming data is then processed and the result is output on another folder. For example: New artwork PDF files arrive in a hot folder and from there they will be automatically trapped and then written to another folder.

However, Access points are not only used to start work on that incoming data. They can also receive *parameters* for the workflow that they will start. These parameters define *what* needs to be done in the workflow with some other (set of) file(s). For example: a Folder Access Point receives an XML from the order entry system. The XML describes a list of re-run print Jobs. And for each **Job** it describes which **Products** need to be linked into that Job and what quantity needs to be printed.

Or, instead of *receiving* those parameters, Access Points can *go and search* for them. For example: a **Database Access Point** looks up the desired trapping distance in an external system. This results in a SmartName that the trapping task then uses.

Other types of Access Points are **FTP, SFTP, Mail, Web Service**. Then there are several variants that get their data from a **Cloud Storage** application. Learn more in [Access Points](#) on page 1777.

**It's all about SmartNames!**

In most cases, these parameters that come in from the external system are turned into SmartNames. These SmartNames are then picked up in the workflow tasks:

- When they describe job or product characteristics that are relevant for the lifetime of the job or product, they can be stored as **Job or Product parameters**,
- When the parameters are relevant only for the workflow started by the access point, they can be used as **workflow parameters**.

### 24.2.2. AE tasks Interacting directly with the External System

Not only Access Points can contact an external system. There are also 2 Automation Engine tasks that are dedicated to interact with external systems. Contrary to Access Points, their interaction can be **bi-directional**. Besides retrieving data from external systems, these tasks can also be used to provide feedback to external systems. This will be described in more detail later. However, these 2 tasks are typically used because the **workflow needs this interaction before it continues**. The result of these tasks will be used in the next steps of the workflow. As usual, this can be creating Jobs or Products, or get values for SmartNames to be used in that workflow.

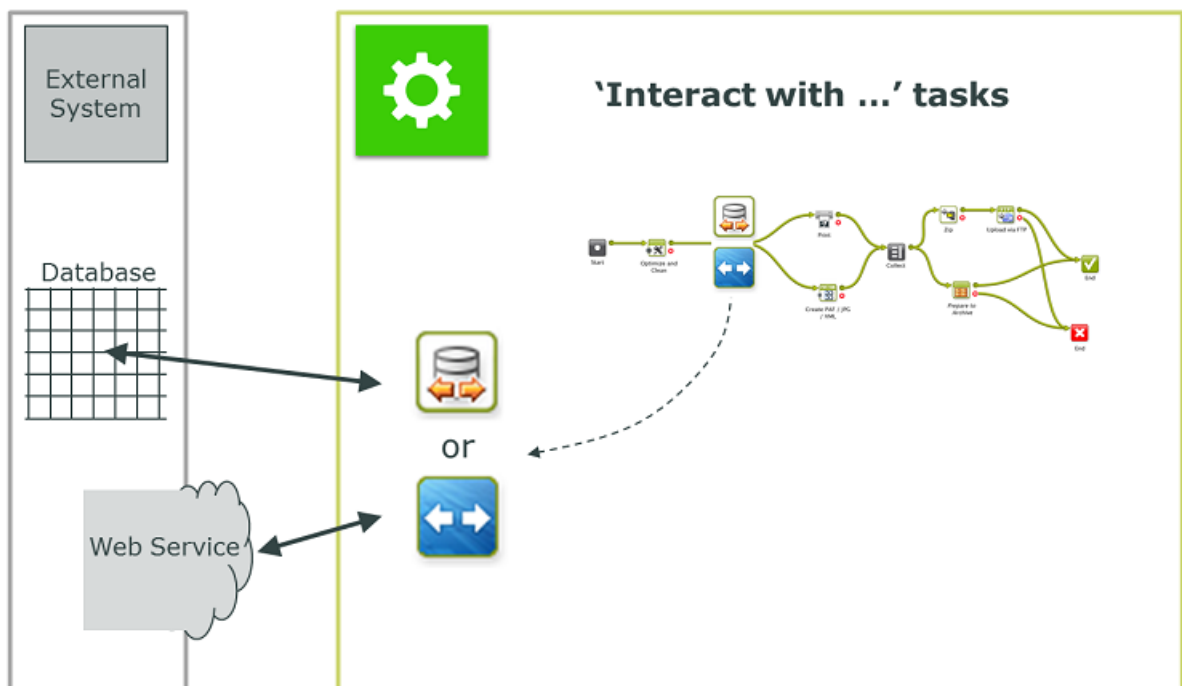

- The **Interact with Database** task 

Automation Engine can use this task to **read** a value from an external database. For example: an operator starts a workflow to Step & Repeat and output. The workflow asks the database of the production planning system on which press this job will be printed. This is needed to know the layout size and also any dot gain curve. This press choice can be decided very late, so it might not have been part of the Job parameters that were created earlier.



**Note:** Reading from an external database is also possible by using a simple SmartName query or by using a Database Access Point.

Automation Engine can also use this task to **write** directly into the database of the external system. For example to inform it on the new status of a Job or Product. When that system can not read XML messages with such information, then you can consider to have Automation Engine write this information directly into the database of that system.



**Attention:** This is a very direct way to have applications connect. This must be well designed and carefully tested.



**Important:** Esko takes no liability for queries that write or change fields in that external database.

- The **Interact with Web Service** task 

The concept is very similar to the one above, but here the task uses HTTP calls to a web service. Also here, both **read** ('GET') and **write** ('POST') commands are possible. When the external system is running a web service, you will be able to access it via HTTP (Hypertext Transfer Protocol). However, you also need to learn **how** to communicate to that system. Some applications will indeed publish their API (Application Programming Interface). For example Automation Engine can use this task to ask a question to Google Maps. This is only possible because Google Maps did publish its API (and runs a web service). This example is illustrated in the chapter [Examples](#) on page 1858.

Typically, both these tasks execute such interactions as part of a larger workflow in Automation Engine. Find their detailed documentation in the chapter [Tasks Interacting with other Systems](#) on page 1842.



**Note:** The **Integrate with WebCenter** task is described in [Advanced WebCenter Integration](#) on page 1758, a chapter of the document on integrating Automation Engine with WebCenter.

### 24.2.3. AE Mapper tasks Transforming Data

Automation Engine offers many ways to use XML to control the workflow. Automation Engine also offers many features to create XML files. But sometimes you need to create an XML with a different content or formatting.

This **Create XML File** task is typically used to create XML files that are to be read by external systems. In such XML files, you sometimes want more or less information. And sometimes you need to re-format data in a way that the external system prefers.

Then there are the specific data formatting tasks like **Split XML**, **Join XML** or **Map Data** task. These are powerful tools that offer many more ways to control XML files. Sometimes the data (information) that comes from an external system first needs to be transformed before it can be used in Automation Engine. Sometimes, these transformations are classic file conversions like CSV to XML. The **Map Data** task was created to do this. Sometimes the XML will first need to be split in several XMLs (**Split XML** task). Sometimes it will be useful to join several data files into one XML (**Join XML** task).

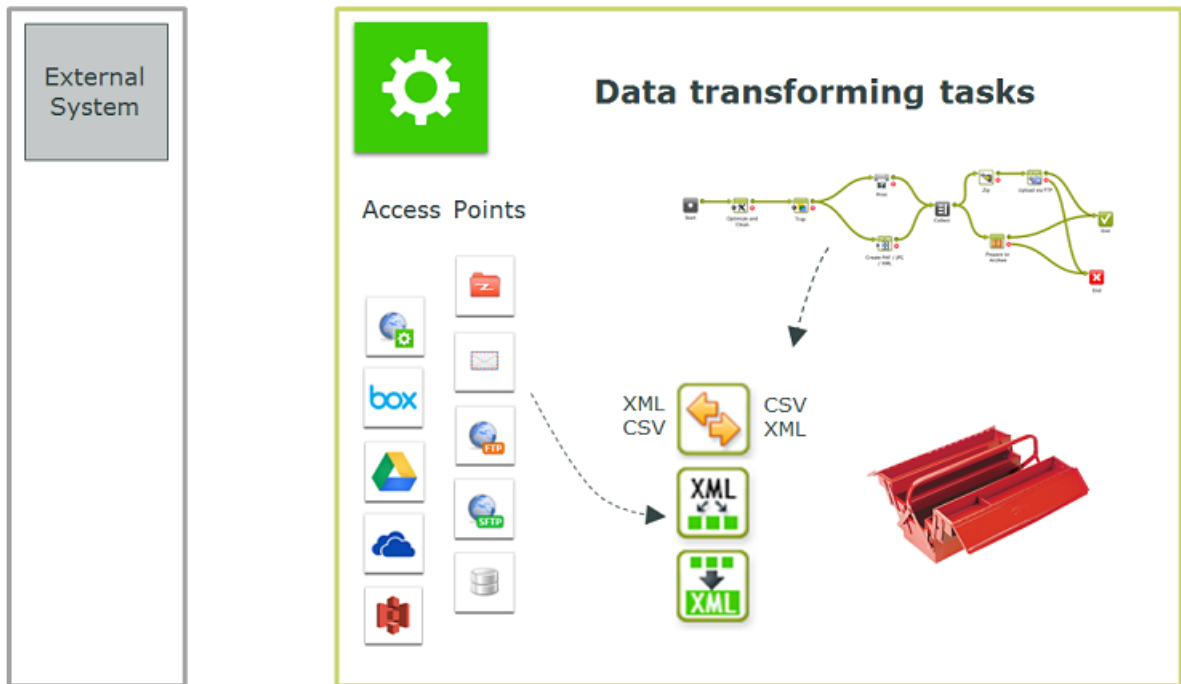

Data transforming tasks can be used at any step in a workflow. They are used

- at the start of a workflow, to help transform what an Access Point delivered.
- at any other point in a workflow, also often at the end, to translate information into a format that the external system prefers.

Find a detailed description of these tasks in the chapter [Data Transforming Tasks](#) on page 1811.

### Transforming data from an Access Point

Here are some examples where data transforming tasks are used right at the beginning of a workflow that is started by an **Access Point**:

- The external system provides a list of jobs to be processed under the form of a large XML that it writes on the **Folder Access Point**. The **Split XML file** task then creates 1 XML file per job entry. These separate XML files are then used for the **Create Job** task.
- The external system sends an CSV file on a **Folder Access Point**. The **Map Data** task first transforms it into an XML. Later in the workflow, SmartNames will get their values by reading from that XML file (Xpath queries).
- Some Access Points do not even result in data files yet. In case of a **Database Access Point** or a **Web Service Access Point**, the accessed data can arrive as a several XML files. This is where you can use the **Join XML** task to create a single and maybe even simpler XML file. Again, that XML file is then typically the base to provide SmartNames their workflow specific value.

### Transforming data from a workflow

There are many moments where it can be necessary to transform Automation Engine information. Typically when sending information to external systems. Some of these external systems have their own mapping tools to read these incoming XMLs anyway. But sometimes you will be asked to have Automation Engine transform this information first.

Some examples:

- The MIS can not read an XML file but can read CSV. This is a classic use case for the **Map data** task.
- The XMP (metadata) of a PDF needs to be sent to the external system as an XML. The **LinkEdge** task does that. But maybe the MIS wants to have the ink coverage information formatted in a different way. And maybe it is also necessary to convert the millimeters into inches.
- When using the **Interact with Web Service** task to ask the web service of Google Maps the distance to a customer, the answer needs to end up in an XML or a SmartName.
- A **Step & Repeat** task requires a specific XML as input file, with a different structure than the one from the external system.
- The **Create Job** task requires information that is present in 3 XMLs, from 3 different sources.
- The XML with feedback that you want to send to the external system needs to contain both a Job status and some meta data from the PDF.

#### 24.2.4. AE sending data Back to the External System

We briefly described this topic in the introduction ([Automation Engine sending commands To an External System](#) on page 1770). Here, we add some detail and mention some tools.

A workflow in Automation Engine always generates output data, and often even many kinds. A lot of that data is not just for other prepress components, but for external systems. We distinguish **2 main types of data**:

- **Sending Prepress data (back)**
  - Data for output devices like proofers and RIPs (CTP, DFE, Press)
  - Data for people, often customer service or sales people or end-customers (PDFs attached in e-mail or sent via FTP)
  - Data for external systems, some of which web-enabled, often to view, approve or exchange 'assets'. In many cases it is not the original production files that are sent but smaller versions (less Mb) or more secure versions like password protected PDFs (JPEGs, RGB-PDFs, viewer streaming data, 3D files...)
- **Sending Communication data (back).** Here, the goal is to inform. Some communication will be about a status, for example 'plates made'. Some will be about describing the (new) prepress data themselves, for example the ink coverage of a production PDF. This communication data can also be files or it could be 'live':
  - Communication *files*: XML, XMP-XML, CSV, TXT
    - written on a network share, typically on a hot folder of the external system
    - sent via e-mail or FTP
  - Communicating *directly* with the external system: (see also [AE tasks Interacting directly with the External System](#) on page 1773.)
    - directly to its database, writing or updating fields
    - directly to the web service of the API of that external system

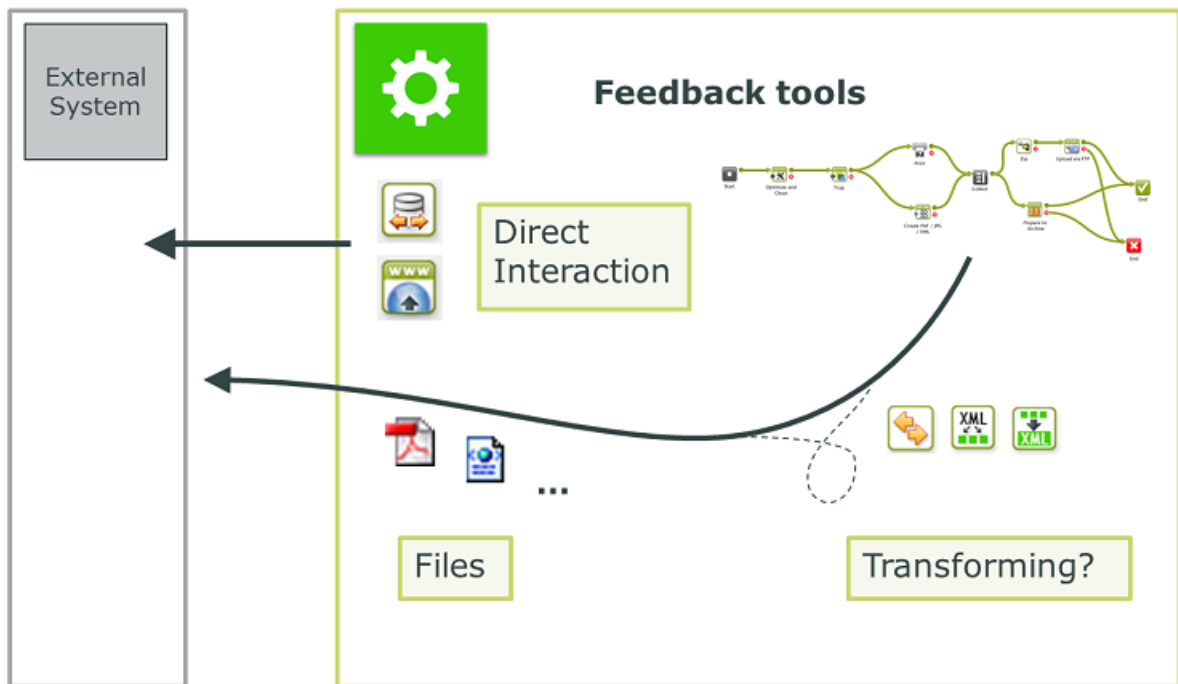

### Transforming data before sending

Sometimes the external system does not support one of the above file formats or interaction protocols. In those cases, the **Map Data** task can help to convert. Find an introduction to this concept in [AE Mapper tasks Transforming Data](#) on page 1774.



**Tip:** You do not always need to send a lot of Mb to send a lot of information. For example: an XML describing de barcode parameters can be more useful than a high-res PDF. You could zoom-in on the PDF but the XML will tell you even the non-visible parameters of that barcode (type, bar width reduction, distortion...).

## 24.3. Access Points



**Note:** We introduced this topic in [AE Access Points Triggering a Workflow on Automation Engine](#) on page 1772.

An Access Point typically launches a workflow after it detected a signal from 'outside'. This signal could be the arrival of files but it could also be some form of a command. It could also be AE itself detecting some change in another system.

Automation Engine offers many types of Access Points. The most classic example is a **Folder Access Point**, which is also often referred to as a 'hot folder'.



**Tip:** We advise you to first read about the [concept of Access Points](#).

### The Access Points View and Tool

The **Access Points** View (in the Views category **Setup**) is where you create, modify and have an overview of your Access Points.

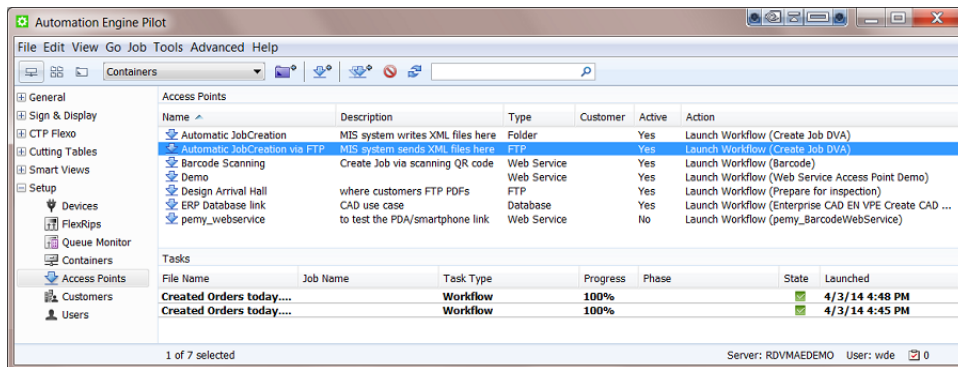





The top part of this view shows a list of all the **Access Points** that you configured.

The bottom part is a task monitor that shows the **Tasks** that were executed by the selected Access Point.

### Working with Access Points (the basics)

We here list the main functionality that is available in tool bar (or via the **File** menu). The next pages add details per type of Access Point.

-  : To **create** a new Access Point.
-  : To **duplicate** an Access Point. The selected Access Point will open with empty fields for Name and Description.
-  : To **delete** a selected Access Point. You will be asked to confirm.
-  : To **'scan now'**. To manually make the selected Access Point scan for new files at that time. This can be useful when you do not want to wait for the time interval (see further).



**Note:** This function is disabled for the **Web Service Access Point**.

To **modify** an existing Access Point, select it from the list and double click it.

To **deactivate** an Access Point, right-click it and choose **Deactivate Access Point**.

### Types



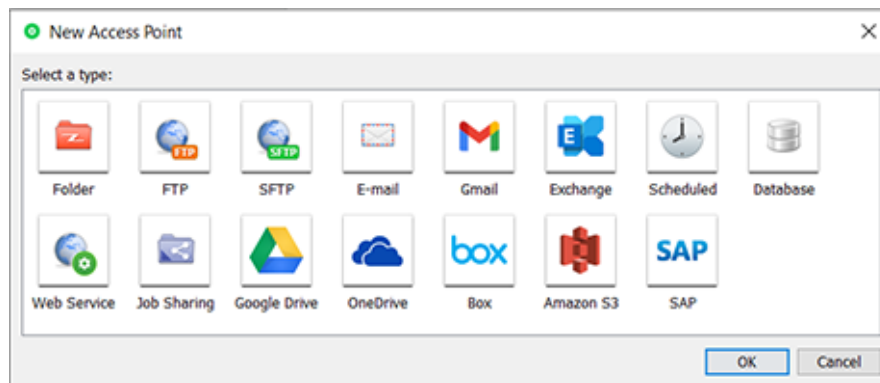

**Differences in how they work**

This table illustrates that some Access Points work in a slightly different way:

**Table: Access Points - technical differences**

Access Point Type	Checks for data at regular time interval ('Polling')	Uploads that data	Starts a workflow
Folder	✓	✓	typically
FTP	✓	✓	typically
SFTP	✓	✓	typically
E-Mail	✓	✓	typically
Gmail	✓	✓	typically
Exchange	✓	✓	typically
Scheduled	-	-	typically
Database	✓	-(**)	typically
Web Service	-(*)	-(***)	always
Job Sharing	✓	✓	typically
Google Drive	✓	✓	typically
OneDrive	✓	✓	typically
Box	✓	✓	typically
Amazon S3	✓	✓	typically

(\*) The external system decides when to contact the Access Point.

(\*\*) The Access Point goes to and gets info from an external database.

(\*\*\*) The Access Point waits until it receives an HTTP command from the external system.

**Access Point SmartNames**

There is a specific category of SmartNames for Access Points. They enable smart re-use of many attributes of an Access Point. Access Point SmartNames are also automatically stored as workflow parameters.

Learn more about SmartNames in the dedicated chapter [SmartNames](#) on page 637.

### 24.3.1. Folder Access Point

#### Concept

##### What is a Folder Access Point?

A **Folder Access Point** monitors a folder located somewhere in an Automation Engine **Container**. Every time one or more files are uploaded into that folder, the **Folder Access Point** will move the files to another folder where they will be processed. **Folder Access Points** are typically created to launch a workflow using those incoming files as input files for that workflow.

However, you can also choose *not* launch a workflow. In that case the **Access Point** only serves to upload files onto a specific folder in an Automation Engine **Container**.



**Note:** The Folder Access Point is the folder itself, not any of its subfolders.



**Tip:** The section [Examples](#) on page 1858 contains an example case of a **Folder Access Point**.



**Note:** **Folder Access Points** can also be used to process incoming JDF files. Learn more about using JDF in [What about JDF?](#) on page 1771.



**Note:** When your Automation Engine server is a SaaS server (has that license), the type 'Folder Access Point' is replaced by a different one: **Agent Folder** Access Point. Learn more in the chapter on [SaaS setup](#).

##### What about Hot Folders?

Before version 14 of Automation Engine, you could create **Hot Folders**. When you upgrade to version 14, they will **not** be automatically migrated to **Folder Access Points**. They will stay hot folders and will still function as they did before.



**Note:** If you created hot folders in a version older than version 14, you will also keep your **Hot Folders** view in the Pilot of your version 14. If you haven't created hot folders in Automation Engine before upgrading to version 14, you will not see the **Hot Folders** view in the Pilot.



**Tip:** When you (manually) convert a hot folder into a folder access point, you can use the **Export Ticket...** button in the setup of the hot folder. You can then use that ticket in the [setup of the Folder Access Point](#).

The following options were previously available in hot folders but are not available in **Folder Access Points**. This is because there are now other and better ways to do these actions:

- the annotation for the workflow task (you now write a 'description').
- grouped launching (you now can still create this effect by using a ZIP, but the most typical use cases are covered when you use the **Gang Run Printing** related features).
- delete input files when the workflow is finished (you now can do this by using a **Delete File** task at the end of your workflow).

### Creating or modifying a Folder Access Point

Follow these steps to create or modify **Folder Access Points**:

1. In the **Pilot** click on **Access Points** view. Alternatively, choose **Tools > Access Points**.
2. In the dedicated **Access Points** view, click on . Alternatively, choose **File > New**.
3. In the resulting window, select **Folder** and click **OK**.  
The **New Folder Access Point** window will open. Here is one with some typical settings already filled in:

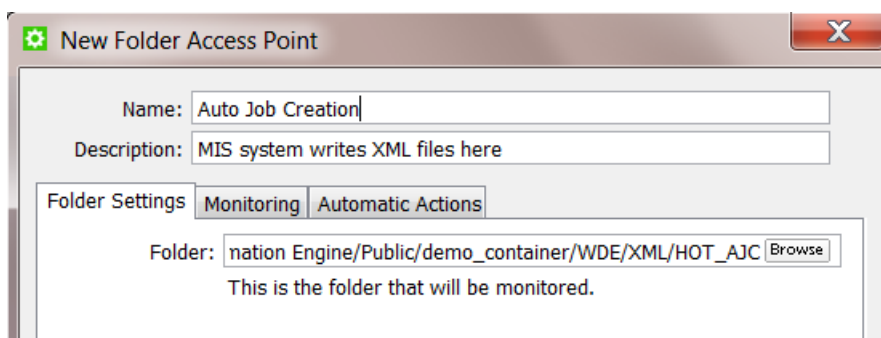

4. Enter a **Name** for the **Access Point**.
  5. If you want, enter a **Description**.  
This will help identifying your **Access Point** without having to read all its settings.
  6. In the tab **Folder Settings**, define which folder will be the actual Access Point that will be monitored by Automation Engine. Use the browse button to indicate it.  
This folder needs to be *inside* a **Container**. This folder may not be inside another **Folder Access Point**.
  7. In the tab **Monitoring**, define the time interval.
    - **Check Every**. Enter the time interval with which Automation Engine should check if any new files came in. Think of the time interval as the *maximum* time it takes for the new files to be picked up.
    - **Schedule**. If you want this Access Point to be inactive during a part of the day, then activate this option and indicate the start and end time of that period.
- 

**Note:** Such a temporary inactive state will not be shown in the general Access Points View. In that View, the column 'Active' shows its *general* status.
8. In the tab **Automatic Actions**, define what needs to happen.
    - **Move Files to**. This is the folder where the files will be processed. These files have to be moved to avoid that the **Access Point** would process the same files again and again.



**Important:** If this destination folder is part of a Job Folder, the workflow that this access point launches will run in the context of that Job.

- **Rename Files to.** If you want you can choose to rename these files too. To do this, enter the new file name.



**Tip:** Typically, SmartNames are used here to help indicate in their name *when* they were processed or *where* they came from.

- **Action.** Choose:
  - **None.** Choose this option when you only want to use this **Access Point** to *move* the files.
  - **Workflow.** Choose this option when you want a workflow to start. Select the workflow ticket from the offered list. The new accessed files will be used as input files for this workflow. If these files are inside a Job Folder, the workflow will be run in the context of that Job.



**Attention:** Make sure your workflow **can** start with the type of files that will arrive.

**Options:**

- **Operator:** Choose the user that will be shown as user for the workflow task.



**Tip:** If you do not want to assign one specific person, you could create an operator named "Access Points" or "Automatic" and assign that one here. Also remember that the Access Points Task Monitor shows you the tasks launched by the selected Access Point.



**Note:** If you leave this option blank, a system user "UPLC" will be used.

- **Priority:** Choose the priority for this workflow: Low, Normal or High. The default priority is 'Normal'.
- **Process JDF:** Choose this option when this Access Point will be used to process incoming JDF files. For more info on JDF, read this section: [What about JDF?](#) on page 1771.

### 24.3.2. FTP Access Point

#### Concept

An **FTP Access Point** monitors a folder on an FTP site. At a regular time interval, it checks if new files have arrived in that folder and it then moves them to a specified folder in an Automation Engine **Container**.



**Note:** There is no FTP server embedded in Automation Engine, so this functionality relies on a FTP server that has been setup separately from Automation Engine.

This also works for new files in any subfolders of the scanned FTP site. Those files will be moved to an identical structure of subfolders that will be automatically created.



**Note:** Non ASCII characters are not supported (ASCII = a-z, A-Z, 0-9).

An FTP access point can also start a workflow on those files.

After uploading them, the access point deletes these files from the FTP site. However, the folders (and subfolders) are not deleted. This way, the folder structure of FTP site stays intact.



**Note:** The **Pilot** also offers a manual way to upload files from an FTP site. When you right-click on a folder or Job Folder, the function **Upload from FTP site** is offered. This **FTP Access Point** is an automated version of that feature.

### Creating or modifying an FTP Access Point

Follow these steps to create or modify **FTP Access Points**:

1. In the **Automation Engine Pilot** go to the **Access Points** View. Alternatively, choose **Tools > Access Points**.
2. In the dedicated **Access Points** View, click on . Alternatively, choose **File > New**.
3. In the resulting window, select **FTP** and click **OK**.  
The **New FTP Access Point** window will open. Here is one with some typical settings already filled in:

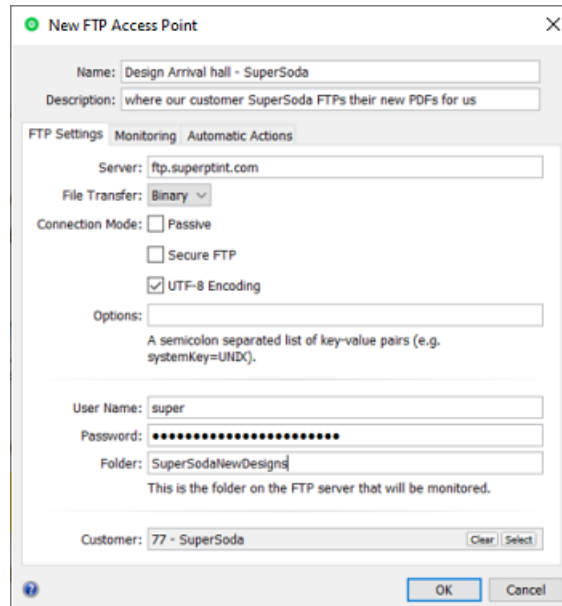

4. Enter a **Name** for the **Access Point**.
5. If you want, enter a **Description**.  
This will help identifying your **Access Point** without having to read all its settings.
6. In the tab **FTP Settings**, define where and how you wish to connect.

- **Server:** Enter the name of the FTP server.

- **File Transfer:** Choose either **Binary** or **ASCII**.



**Tip:** **Binary** will always work, but if you have an ASCII file, the transfer speed will be higher when you choose **ASCII**.

- **Connection Mode:**

- Select **Passive** if there is a firewall between the FTP server and Automation Engine that is blocking the FTP server from setting up connections to Automation Engine.



**Tip:** By default, the FTP transfer uses Active Connection Mode (where the FTP server opens the data connection). When **Passive** is selected, the system will use Passive Connection Mode instead (where the client initiates the connection).

- Select **Secure FTP** if you are connecting to a secure FTP server (over FTPS, not SSL or SSH). If you are experiencing problems using secure FTP, try connecting over regular FTP and ask your IT administrator to check the security settings of your FTP server.
- Select **UTF-8 Encoding** to avoid encoding problems in file names. For example when downloading file names with French characters onto a Chinese FTP server.
- **Options:** A field for one or more exceptional options, formatted as key-value pairs. For example: When you experience problems when interfacing to a Rumpus FTP Server, add `systemKey=UNIX` in this field and try again.
- **User Name** and **Password:** Enter a valid user name and password for this FTP server.
- **Folder:** This is the folder on the FTP server that will be monitored. As mentioned in [Concept](#) on page 1782, also its subfolders will be monitored.
- **Customer:** If you want to link a specific customer to this Access Point, use **Select** to pick it from the list. Then you can use it as a SmartName.

**7.** In the tab **Monitoring**, define the time interval.

- **Check Every.** Enter the time interval with which Automation Engine should check if any new files came in. Think of the time interval as the *maximum* time it takes for the new files to be picked up.
- **Schedule.** If you want this Access Point to be inactive during a part of the day, then select this option and indicate the start and end time of that period.



**Note:** Such a temporary inactive state will not be shown in the general Access Points View. In that View, the column 'Active' shows its *general* status.

**8.** In the tab **Automatic Actions**, define what needs to happen.

- **Move Files to.**
  - **Folder.** Indicate where you want the files to be moved to. Browse to a folder in a **Container**.



**Important:** If this destination folder is part of a Job Folder, the workflow that this access point launches will run in the context of that Job.

- **Customer's Upload Folder.** Alternatively, you can choose to move these files to the **Customer's Upload Folder**. This is a folder you can define in the definition of the **Customer**.
- **Rename Files to.** If you want you can choose to rename these files too. To do this, enter the new file name.



**Tip:** Typically, SmartNames are used here to help indicate in their name *when* they were processed or *where* they came from.

- **Action.** Choose:
  - **None.** Choose this option when you *only* want to use this **Access Point** to *move* the files.
  - **Workflow.** Choose this option when you also want a workflow to start. Select the workflow ticket from the offered list. The new accessed files will be used as input files for this workflow. If these files are inside a Job Folder, the workflow will be run in the context of that Job.



**Attention:** Make sure your workflow **can** start with the type of files that will arrive.

**Options:**

- **Operator:** choose the operator that will be shown as operator for the workflow task.



**Tip:** if you do not want to assign one specific person, you could create an operator named "Access Points" or "Automatic" and assign that one here. Also remember that the Access Points Task Monitor shows you the tasks launched by the selected Access Point.

- **Priority:** choose the priority for this workflow: Low, Normal or High. The default priority is 'Normal'.
- **Process JDF.** Choose this option when this Access Point will be used to process incoming JDF files. For more info on JDF, read [What about JDF?](#) on page 1771.

### 24.3.3. SFTP Access Point

**Concept**

An **SFTP Access Point** monitors a folder on an SFTP site. At a regular time interval, it checks if new files have arrived in that folder and then moves them to a specified folder in an Automation Engine **Container**.

This also works for new files in any subfolders of the scanned SFTP site. By default, those files will be moved to an identical structure of subfolders that will be automatically created (learn more options below).

After downloading them, the access point deletes these files from the SFTP site. The folder structure on the SFTP site is kept.

An SFTP access point can also start a workflow on those files.

There is also a task that serves to upload files from within a container to such an SFTP site. Learn more in [Task 'Upload via SFTP'](#) on page 1808.



**Note:** The difference between SFTP and FTP(S):

**FTPS** (secure FTP) is the FTP protocol on top of SSL (similar to how HTTPS is the SSL secure version of HTTP). Do not confuse FTPS with SFTP, which uses SSH (secure shell). **SFTP** is seen as more reliable and secure and can also solve issues with firewalls. Learn more in this [online article describing the difference between FTPS and SFTP](#).

### Creating or modifying an SFTP Access Point

Most steps and options are equal to those described for an [FTP Access Point](#). When creating one, select the type **SFTP**.

In the setup dialog, click **Configure...** for direct access to the [SFTP sites item in the Configure tool](#). This configure item is where you manage the specifics of the SFTP authentication.

### Creating and Copying Folder names

In many cases, not just the name of the file is interesting, but also the place where it was stored on the SFTP server. It might therefore be useful to re-use (parts of) that folder structure on the Automation Engine container. The folder names can also contain many other forms of information: their name might reflect the customer name, job order ID, production category, etc.

Learn about how to re-use the names of those remote folders and combine them with SmartNames [in this section describing the same possibilities for the cloud storage access points](#).

### File and Folder Name Limitations

- [Windows' "reserved characters"](#) are not supported, nor in the name of the destination folder nor in the names of the files that you download. See their list [here](#).
- Non ASCII characters (ASCII = a-z, A-Z, 0-9) are only supported if the SFTP server you are downloading from uses UTF8 encoding.

## 24.3.4. E-Mail Access Point

### Concept

An **E-mail Access Point** scans an e-mail account and extracts the e-mail attachments of new incoming e-mail. These files are uploaded to a folder in a **Container**. An **E-mail Access Point** can also start a workflow on those files.

Once the attachments were successfully extracted, the e-mail will be deleted.





**Note:** This generic E-mail Access Point uses the basic authentication protocol (based on user name/password). There are also dedicated access points for *Gmail* and for *MS Exchange* which use OAuth2, a more secure (token-based) authentication & authorization protocol.

Here are 2 typical examples of how **E-mail Access Point** SmartNames can help you do even more:

- You can agree with the e-mail sender to start the subject line with the Job number. This helps you to direct these files to the right folder.
- The e-mail address of the e-mail sender can be used to later send him an e-mail back about the status of the files he sent.



**Attention:** E-mail access points are not recommended in case the attachments are larger than 10 Mb. There are better alternatives to transfer large amounts of data, such as (s)FTP(S) or cloud storage.



**Note:** A too large attachment will lead to the e-mail not being picked up - this will be mentioned in the bgmd log file.



**Note:** Note that the real size limits of e-mail attachments are actually determined by the configuration of the mail server that you use, not by Automation Engine.

### Creating or modifying an E-Mail Access Point

Follow these steps to create or modify **E-Mail Access Points**:

1. In the **Pilot** click on **Access Points** view. Alternatively, choose **Tools > Access Points**.
2. Click on to create a new **Access Point**. Alternatively, choose **File > New**.
3. In the resulting window, select **E-mail** and click **OK**.

The **New E-mail Access Point** window will open up. An example:

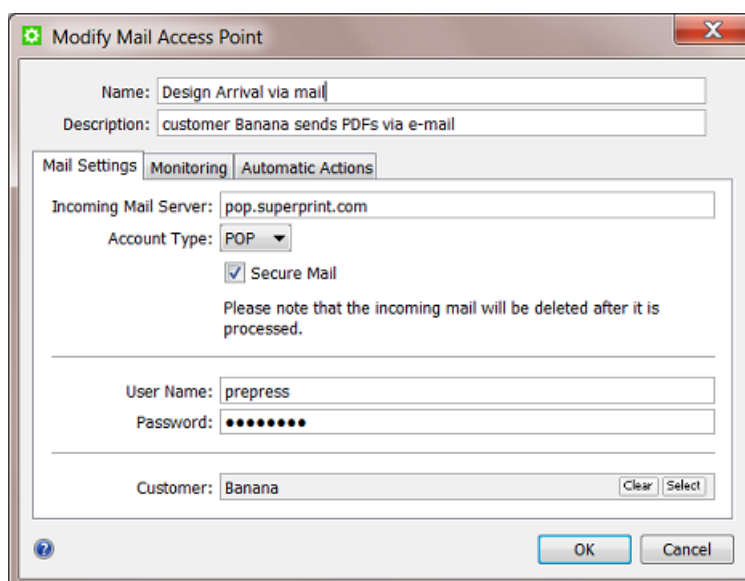

4. Enter a **Name** for the **Access Point**.

5. If you want, enter a **Description**.

This will help identifying your **Access Point** without having to read all its settings.

6. Define the **Mail Settings**:

Some examples:

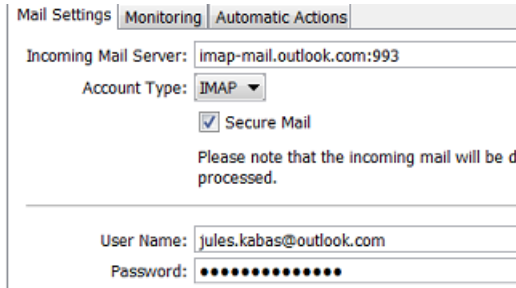

Mail Settings | Monitoring | Automatic Actions

Incoming Mail Server:

Account Type:

Secure Mail

Please note that the incoming mail will be processed.

---

User Name:

Password:

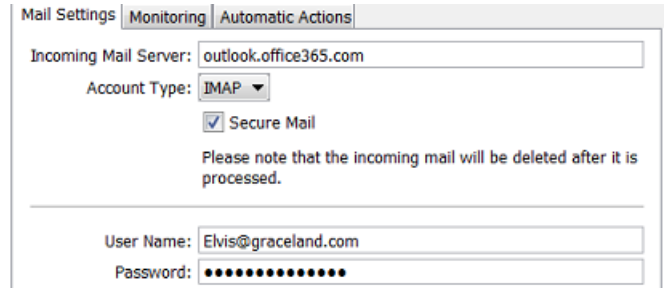

Mail Settings | Monitoring | Automatic Actions

Incoming Mail Server:

Account Type:

Secure Mail

Please note that the incoming mail will be deleted after it is processed.

---

User Name:

Password:

- **Incoming Mail Server:** Enter the name of the mail server.
- **Account Type:** Depending on the mailbox configuration, choose either **POP** or **IMAP**. See examples of both in above screenshots.
- **Secure Mail:** Select this if the mailbox is a secure type.
- **User Name** and **Password:** Enter the user name and password of the E-mail account that will receive the E-mails that you want to access.
- **Customer:** If you want to link a specific customer to this Access Point, use **Select** to pick it from the list. You can then use it as a SmartName.

7. In the tab **Monitoring**, define the time interval.

- **Check Every.** Enter the time interval with which Automation Engine should check if any new files came in. Think of the time interval as the *maximum* time it takes for the new files to be picked up.
- **Schedule.** If you want this Access Point to be inactive during a part of the day, then activate this option and indicate the start and end time of that period.



**Note:** Such a temporary inactive state will not be shown in the general Access Points View. In that View, the column 'Active' shows its *general* status.

8. In the tab **Automatic Actions**, define what needs to happen.



**Attention:** E-mail access points are not recommended in case the attachments are larger than 10 Mb. There are better alternatives to transfer large amounts of data, such as (s)FTP(S) or cloud storage.



**Note:** Note that the real size limits of e-mail attachments are actually determined by the configuration of the mail server that you use, not by Automation Engine.

- **Move Files to.**
  - **Folder.** Indicate where you want the files to be moved to. Browse to a folder in a **Container**.



**Important:** If this destination folder is part of a Job Folder, the workflow that this access point launches will run in the context of that Job.

- **Customer's Upload Folder.** Alternatively, you can choose to move these files to the **Customer's Upload Folder**. This is a folder you can define in the definition of the **Customer**.
- **Rename Files to.** If you want you can choose to rename these files too. To do this, enter the new file name.



**Tip:** Typically, SmartNames are used here to help indicate in their name *when* they were processed or *where* they came from.

- **Action.** Choose:
  - **None.** Choose this option when you only want to use this **Access Point** to *move* the files.
  - **Workflow.** Choose this option when you want a workflow to start. Select the workflow ticket from the offered list. The new accessed files will be used as input files for this workflow. If these files are inside a Job Folder, the workflow will be run in the context of that Job.



**Attention:** Make sure your workflow **can** start with the type of files that will arrive.

**Options:**

- **Operator:** choose the operator that will be shown as operator for the workflow task.



**Tip:** if you do not want to assign one specific person, you could create an operator named "Access Points" or "Automatic" and assign that one here. Also remember that the Access Points Task Monitor shows you the tasks launched by the selected Access Point.

- **Priority:** choose the priority for this workflow: Low, Normal or High. The default priority is 'Normal'.
- **Process JDF.** Choose this option when this Access Point will be used to process incoming JDF files. For more info on JDF, read this section: [What about JDF?](#) on page 1771.

### 24.3.5. Gmail Access Point

We here only list the differences with the generic [E-Mail Access Point](#) on page 1786.

**Gmail Settings**

- **Account:** Select one of the Gmail accounts that were already configured on your Automation Engine.
- **Configure...:** Click here to open the Configure tool and see the item **E-mail Accounts**.

Learn more in [E-mail Accounts](#) on page 190.

### 24.3.6. Exchange Access Point

We here only list the differences with the generic [E-Mail Access Point](#) on page 1786.

#### Exchange Settings

- **Account:** Select one of the Exchange accounts that were already configured on your Automation Engine.
- **Configure...:** Click here to open the Configure tool and see the item **E-mail Accounts**.

Learn more in [E-mail Accounts](#) on page 190.

### 24.3.7. Scheduled Access Point

#### Concept

This tool enables to launch a workflow at scheduled times. Typically, an administrator sets this up to execute some recurring maintenance tasks.

The selected workflow ticket is started without any input files.

#### Settings

- **Frequency:**

- Select the main interval **Hourly**, **Daily**, **Weekly** or **Monthly** and use the fields **every** and **at** to further specify.
- Select **Custom** to define any other schedule by using a **Cron Expression**. Learn more below.



**Note:** Right after selecting 'Custom' you will see the cron expression that represented the previously selected schedule. This is helpful to learn cron expressions.

Frequency:  ▾

Cron Expression:

at 8:00 AM, only on Sunday

- **Next at:** A description of the resulting next time that this workflow is scheduled.



**Note:** While typing a cron expression, this field shows instant feedback on its formatting. It clarifies if it is a valid expression and what it stands for.

- **Launch Workflow:** Select the workflow ticket that should be launched at that scheduled time. Remember that the workflow does not require any input files.
- **Options...:** Define the task's **Priority** and which **User** should be used to launch it.

### About Cron Expressions

Cron expressions are like [regex expressions](#) but for scheduling purposes. Learn about cron expressions on <https://en.wikipedia.org/wiki/Cron>.

Technically, Automation Engine uses the library of Quartz to handle the cron expressions. Learn more and see many examples on <http://www.quartz-scheduler.org/documentation/quartz-2.3.0/tutorials/crontrigger.html>.

## 24.3.8. Database Access Point

### Concept

A **Database Access Point** reads, at a regular time interval, information from an external database. That information is written into one or more XML files. The **Database Access Point** can also start a workflow.

A typical use case is checking an external system for a new status. That new status will be a reason for Automation Engine to start an action. For example: In that external database, when the status of a Job or Product is found on "preflight required", Automation Engine starts a preflight workflow on that Job or Product. Or AE could start output workflows for all Jobs that are found in a status "Jobs to expose".



**Tip:** The chapter [Examples](#) on page 1858 contains an example case of a **Database Access Point**.

To prevent that these statuses keep triggering these actions over and over again, the **Database Access Point** offers the choice to update or delete those (status) fields. For example: the status "Proof required" would be updated to "Proof started on Esko".

These use cases are often identical to those where an external system sends an XML file to Automation Engine. Here are some typical reasons to use a **Database Access Point** instead of such an XML transfer:

- The external system can not export the wanted data to XML. Or it would require an expensive intervention or an upgrade of the software version.
- Exporting an XML would be a manual action by a user of that external system. And all manual actions can be forgotten.



**Restriction:** In an [AE SaaS](#) setup, you can not use a Database Access Point.

### Creating or modifying a Database Access Point

Follow these steps to create or modify a **Database Access Point**:

1. In the **Pilot** click on **Access Points** view. Alternatively, choose **Tools > Access Points**.
2. Click on to create a new **Access Point**. Alternatively, choose **File > New**.
3. In the resulting window, select **Database** and click **OK**.  
The **New Database Access Point** window will open up. Here is one with some typical settings already filled in:

4. Enter a **Name** for the **Access Point**.
5. If you want, enter a **Description**.  
This will help identifying your **Access Point** without having to read all its settings.

6. Define the **Database Settings**:

- **External Database:** Select the database from the list. The list shows the **External Databases** that you configured via **Tools > Configure**.
- Enter the desired **SQL Select Query**: The query will search for records or it will search specific values in one or more columns. An XML file will be generated for each record that matches the query.

Here is an example of a such an XML file. The query was looking for more info on Jobs with the status 'New'. This XML shows the resulting details of the Job 1213. See how the 'Select \*' returned all the columns of the row of this Job 1213: name, operation etc...

```
?xml version="1.0" encoding="UTF-8?>
<design select="SELECT * FROM design WHERE status = "NEW"" producer="DBPoller-
MIS-1" created="2013-04-24T11:26:14.210+02:00">
  <id>1213</id>
  <name>MyDesign</name>
  <operation>CreateJobCard</operation>
  <width>12</width>
  <height>500</height>
  <depth>50</depth>
  <status>NEW</status>
</design>
```



**Note:** As soon as you select a **Database Access Point**, the query will be checked if it is valid. If it is not valid, an error message will be shown.

- **After Processing:** Now choose what should happen after the results from the query were processed.
  - **Delete the records:** This will delete the records that the query selected in the external database. It will make them empty.
  - **Update the records:** This will update the records that the query selected in the external database with a new value. Click on **Add** to update the desired parameters. Fill in the **Column Name** and the **New Value** in that database column and click OK.



**Note:** If you want to update a record that contains a date and/or time, use the format **yyyyMMddHHmmss** for the new value of the column or use **now** to insert the date and time of the moment that the record is updated.

7. In the tab **Monitoring**, define the time interval.

- **Check Every.** Enter the time interval with which Automation Engine should execute this database query.
- **Schedule.** If you want this Access Point to be inactive during a part of the day, then activate this option and indicate the start and end time of that period.



**Note:** Such a temporary inactive state will not be shown in the general Access Points View. In that View, the column 'Active' shows its *general* status.

8. In the tab **Automatic Actions**, define what needs to happen.

- **Move Files to.** Indicate where you want the resulting XML file(s) to be written. Browse to a folder in a **Container**.



**Important:** If this destination folder is part of a Job Folder, the workflow that this access point launches will run in the context of that Job.

- **Rename Files to.** If you want you can choose to rename these files too. To do this, enter the new file name.



**Tip:** Typically, SmartNames are used here to help indicate in their name *when* they were processed or *where* they came from.

- **Action.** Choose:

- **None.** Choose this option when you want no further action.
- **Workflow.** Choose this option when you also want a workflow to start. Select the workflow ticket from the list. If these files are inside a Job Folder, the workflow will be run in the context of that Job.



**Attention:** Make sure your workflow finds its input files. These can be the XML files from the query but that is not required.

**Options:**

- **Operator:** choose the operator that will be shown as operator for the workflow task.



**Tip:** if you do not want to assign one specific person, you could create an operator named "Access Points" or "Automatic" and assign that one here. Also remember that the Access Points Task Monitor shows you the tasks launched by the selected Access Point.

- **Priority:** choose the priority for this workflow: Low, Normal or High. The default priority is 'Normal'.

### 24.3.9. Web Service Access Point

**Concept**

When a system has a web service, other software applications can send commands or queries to that system by using HTTP requests to the URL of the web service.



**Note:** This type of communication is a solution when the two systems you can not exchange (XML) files on hot folders. This is the case when the two systems are not in the same LAN or can't use shared folders due to security limitations.

Automation Engine also has a web server. A **Web Service Access Point** is a way for external systems to start workflows on Automation Engine by sending a command to the web service of Automation Engine.





**Tip:** In [this section on differences between Access Points](#), you can read how a **Web Service Access Point** works somewhat different than the other types of Access Points. One important difference is that the **Web Service Access Point** does not use the concept of time intervals. It is the external system that fully decides **when** to send a command to Automation Engine.

The HTTP requests can be both HTTP POST requests and HTTP GET requests. If the HTTP POST request also 'posts' data files, then they will be used as input files for the workflow that will be started.



**Note:** When using a HTTP GET request, parameters of the web service call are encoded in the URL using HTTP query strings. When using HTTP POST requests, the parameters are encoded in the content part of the HTTP request.



**Note:** Automation Engine also offers tasks that can convert JSON data into XML and vice versa. Learn more in [Task 'Convert JSON to XML'](#) on page 1811 and in [Task 'Convert XML to JSON'](#) on page 1813.

## Configuring and Checking the Automation Engine Web Service

### Purpose

The web service of Automation Engine will be running automatically on the Automation Engine server.



**Note:** This web service is also used when you access the [AE Server ADMIN web page](#) in a browser.

You can check the status of the Automation Engine Web Service by entering this in a browser: `http://<name of your server>:<port>/ws/`. The port number is the one as defined in the **Configure** tool > **Automation Engine Web Service**. By default this port number is 4415.

For example: If your Automation Engine server is named AESERVER1, then the URL to enter in your browser is `http://aeserver1:4415/ws/`.

The web page that then appears offers more guidelines on formatting more detailed HTTP commands.

### Security

To obtain more security, communicating with a Web Server can be encrypted. Encryption is done using the **private key** of a **certificate**. Decryption is done using the **public key** of a certificate.

Another way to obtain more security when communicating with a Web Server is to require authentication to get access to certain services. This means that one must prove that he is who he claims to be.

### Settings

You have the choice to enable HTTP and/or to enable HTTPS. Usually, only one of the two is chosen.

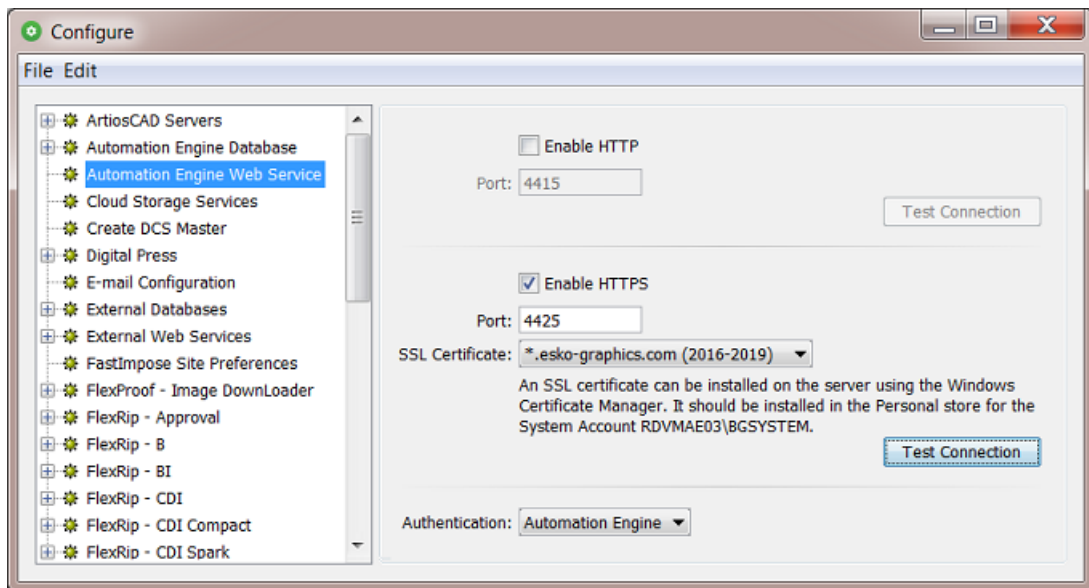

- **Enable HTTP**

- Enter the correct **Port** number.
- Click **Test Connection** to test it. This opens the default browser and issues a HTTP-GET command to the context of the Access Points. If the HTTP-GET succeeds, an HTTP-POST will most likely also be possible.

- **Enable HTTPS**

HTTPS creates a secure channel over an insecure network. Learn more on [this wiki-page](#).

- Enter the correct **Port** number.
- **SSL Certificate** (mandatory option): This is the official certificate that will do the encryption. The name mentioned here is its 'friendly name'. This official certificate must be imported in 'Windows Certificate Manager' (certmgr.msc) in the 'Personal-Certificates' for the 'Service Account' of the (Master) Automation Engine server. This is typically the user 'BGSystem'.



**Note:** To learn more on how to import a certificate in Windows Certificate Manager, consult the Microsoft documentation corresponding to your OS version.



**Attention:** Automation Engine only supports the usage of officially trusted certificates (as signed by and to be bought from a Certificate Authority (CA) and to be imported in the Windows Certificate Manager.

- Click **Test Connection** to test it. This opens the default browser and issues a HTTP-GET command to the context of the Access Points.

If the HTTP-GET succeeds (SSL-Handshake + Authentication if configured), an HTTP-POST will most likely also be possible.

For HTTPS, the FQDN (fully qualified domain name) for the AE master server is calculated (DNS) and used in an attempt to use a host name that better matches the certificate.

- **Authentication:** Choose here whether the web service requires an authentication.
  - **No** authentication.

- **"Automation Engine"** authentication. In this case, users must authenticate with the 'AE LogonServer'. This means they need to use the same credentials as when they log on to the Pilot. User names should adhere to this form: `user@aeserver`, For example `admin@AEserver01`.



**Note:** Only the 'BASIC' HTTP authentication protocol is supported.

### Creating a Web Service Access Point



**Note:** Setting up a **Web Service Access Point** is simple. The complexity lies in the content of the HTTP requests that are sent to it (see next pages).

Follow these steps to create a **Web Service Access Point**:

1. In the **Pilot** click on **Access Points** view. Alternatively, choose **Tools > Access Points**.
2. Click on to create a new **Access Point**. Alternatively, choose **File > New**.
3. In the resulting dialog, select **Web Service** and click **OK**.  
The **New Web Service Access Point** dialog will open up. Here is one with some typical settings already filled in:

4. Enter a **Name** for the **Access Point**.  
This name will automatically be used to complete the URL for this Access Point.
5. If you want, enter a **Description**.

This will help identifying your **Access Point** without having to read all its settings.

- 6. **URL:** See the resulting URL. This is where the external system needs to send its command to launch the workflow defined below.
- 7. **Launch Workflow:** Select the workflow ticket that this Access Point will start.

**Options:**

- **Operator:** choose the operator that will be shown as operator for the workflow task.



**Tip:** If you do not want to assign one specific person, you could create an operator named "Access Points" or "Automatic" and assign that one here. Also remember that the Access Points Task Monitor shows you the tasks launched by the selected Access Point.

- **Priority:** choose the priority for this workflow: Low, Normal or High. The default priority is 'Normal'.

8. **Communication:** Define if you want this Access Point to use synchronous communication.

- When the web service is **asynchronous**, the web service responds to the caller immediately after adding the workflow to the queue with a standard message mentioning the task-id of the queued workflow. The web service will not wait for the workflow to execute and finish. See some examples of such a response in [HTTP Responses](#) on page 1802.
- When the web service is **synchronous**, the web service only responds to the caller when the workflow is finished. In this case the response is the result of that workflow, its output files. See some examples of such a response in [HTTP Responses](#) on page 1802.

Use this when the external system needs to do something with the output of the workflow when it is finished. For example: An external web application that creates boxes on demand, asks automation engine to create a preview of the box, as soon as it's created that preview is then presented to the user in the web application.



**Attention:** One or more of the Automation Engine server's processing channels could be reserved for processing these incoming HTTP requests. This can help avoid that the response is delayed because of other tasks. Learn more in the [AE Server Admin web page](#), in the [Server Setup](#) on page 2011.

**Timeout:** When the external system has not received a response after this time, the workflow will be cancelled.

## HTTP POST Requests

### Launching a workflow using an HTTP POST request

The HTTP POST requests must meet the following requirements:

- The value of the **Content-Type** header of the HTTP POST request should be, in most cases, **multipart/form-data**.
- HTTP request parts can be added to the HTTP POST requests to attach data files and/or to add parameters (also see further).
- For every HTTP request part that is added to an HTTP POST request, a **Content-Disposition** header should be present.

- For each data file, the (UTF-8 encoded) file name of the data file should be specified in the corresponding **Content-Disposition** header.
- For each parameter, the name of the parameter should be specified in the corresponding **Content-Disposition** header.
- The encoding of the HTTP POST requests should be **base64** or no encoding (for example **binary**, **8bit**,...).

For example:

```
POST /ws/myFavoriteWorkflow HTTP/1.1
Host: aeserver01:4415
Content-Type: multipart/form-data; boundary=-----146677a63ef
Content-Length: <length of request body in octets (8-bit bytes)>
...
-----146677a63ef
Content-Disposition: form-data; name="wfparam1"

2mm
-----146677a63ef
Content-Disposition: form-data; name="wfparam2"

4mm
-----146677a63ef
Content-Disposition: form-data; name="inputfile1"; filename="inputfile1.pdf"
Content-Transfer-Encoding: binary
<binary contents of inputfile1.pdf>
-----146677a63ef
Content-Disposition: form-data; name="inputfile2"; filename="inputfile2.pdf"
Content-Transfer-Encoding: binary
<binary contents of inputfile2.pdf>
```

### Attaching data files to be used as input files for the workflow that is launched

You can attach data files to be used as input files for the workflow that is launched by adding them as HTTP request parts to the HTTP POST request. For each data file, the (UTF-8 encoded) file name of the data file should be specified in the corresponding **Content-Disposition** header.

For example:

```
POST /ws/myFavoriteWorkflow HTTP/1.1
Host: aeserver01:4415
Content-Type: multipart/form-data; boundary=-----146677a63ef
Content-Length: <length of request body in octets (8-bit bytes)>
...
-----146677a63ef
Content-Disposition: form-data; name="inputfile1"; filename="inputfile1.pdf"
Content-Transfer-Encoding: binary
<binary contents of inputfile1.pdf>
...
```

When the workflow is launched, the data files are handled in one of the following ways:

- When the workflow is launched in a specific Job, the data files will be moved to the Job Folder.
- When the workflow is not launched in a specific Job and the workflow is successfully finished, the data files will be deleted.

- When the workflow is not launched in a specific Job and the workflow did not finish successfully, the data files will be kept in this shared folder:

```
\\<name of your server>\AutomationEngineTmpFolder
```

When no data files are attached to the HTTP POST request, the **Web Service Access Point** will generate an XML file containing some information about the HTTP GET request. This XML file will then be used as input file for the workflow to be launched and will be handled in the same way as attached data files would be handled.

### Launching a workflow with only a single input file ('PLAIN POST')

Since AE 16.1, you can also POST a PLAIN file, rather than a 'multipart' post containing the file(s).

For example:

```
POST /ws/myFavoriteWorkflow HTTP/1.1
Host: aeserver01:4415
Content-Type: text/xml
Content-Length: <size of inputfile>

<binary contents of inputfile>
```

### Launching a workflow in a specific Job

You can specify the Job in which the workflow should be launched by adding parameters as HTTP request parts to the HTTP POST request. The name of each parameter should be specified in the corresponding **Content-Disposition** header.

The Job in which the workflow should be launched can be specified using the **Job ID**, the **Job Name**, the **Order ID** or using both the **Order ID** and the **Sub Order ID**. The parameters you need to add as HTTP request parts to the HTTP POST request are, respectively, **jobid**, **jobname**, **orderid** or **orderid** and **suborderid**. The values for these parameters should be UTF-8 encoded.

For example:

```
POST /ws/myFavoriteWorkflow HTTP/1.1
Host: aeserver01:4415
Content-Type: multipart/form-data; boundary=-----146677a63ef
Content-Length: <length of request body in octets (8-bit bytes)>
...

-----146677a63ef
Content-Disposition: form-data; name="orderid"

2014-100254
...
```

### Specifying the values of the workflow parameters of the workflow that is launched

You can also set the values of the workflow parameters of the workflow by adding parameters as HTTP request parts to the HTTP POST request. These parameters should have the same names as the names of the workflow parameter(s) which value you want to set. The values for these parameters should be UTF-8 encoded. For each parameter, the name of the parameter should also be specified in the corresponding **Content-Disposition** header.

For example:

```
POST /ws/myFavoriteWorkflow HTTP/1.1
Host: aeserver01:4415
Content-Type: multipart/form-data; boundary=-----146677a63ef
Content-Length: <length of request body in octets (8-bit bytes)>
...

-----146677a63ef
Content-Disposition: form-data; name="wfparam1"

2mm
...
```

## HTTP GET Requests

### Launching a workflow using an HTTP GET request

When using HTTP GET requests to launch workflows on a **Web Service Access Point**, no data files can be attached.

Every time an HTTP GET request is received on the URL of the **Web Service Access Point**, it will generate an XML file containing some information about the HTTP GET request. This XML file can then be used as input file for the workflow to be launched.

- When the workflow is launched in a specific Job, this XML file will be moved to the Job Folder.
- When the workflow is not launched in a specific Job and the workflow is successfully finished, this XML file will be deleted.
- When the workflow is not launched in a specific Job and the workflow did not finish successfully, this XML file will be kept in this shared folder:

```
\\<name of your server>\AutomationEngineTmpFolder
```

### Launching a workflow in a specific Job

You can specify the Job in which the workflow should be launched by adding parameters to the query string of the HTTP URL. The Job in which the workflow should be launched can be specified using the **Job ID**, the **Job Name**, the **Order ID** or using both the **Order ID** and the **Sub Order ID**. The parameters you need to add to the query string of the HTTP URL are, respectively, **jobid**, **jobname**, **orderid** or **orderid** and **suborderid**. The values for these parameters should be UTF-8 encoded.

For example:

```
http://aeserver01:4415/ws/myFavoriteWorkflow?jobid=ee6b08ca-eecf-4cb7-b2e1-254c20d82546
http://aeserver01:4415/ws/myFavoriteWorkflow?jobname=Libelle-2014-week12
http://aeserver01:4415/ws/myFavoriteWorkflow?orderid=2014-100254
http://aeserver01:4415/ws/myFavoriteWorkflow?orderid=2014-100255&suborderid=001
```

### Specifying the values of the workflow parameters of the workflow that is launched

You can also set values for workflow parameters by adding parameters to the query string of the HTTP URL. These parameters should have the same names as the names of the workflow parameter(s) which value you want to set. The values for these parameters should be UTF-8 encoded .

For example:

```
http://aeserver01:4415/ws/myFavoriteWorkflow?wfparam1=2mm
```

```
http://aeserver01:4415/ws/myFavoriteWorkflow?wfparam1=2mm&wfparam2=4mm
http://aeserver01:4415/ws/myFavoriteWorkflow?jobname=Libelle-2014-week12&wfparam1=2mm
```

## HTTP Responses



**Attention:** When using a **Web Service Access Point**, the corresponding HTTP responses should always be checked because they can contain error messages.

As mentioned earlier, the response is different if the communication is *synchronous or asynchronous*.

### Asynchronous Communication Responses

- In case the workflow was successfully launched, the HTTP response will contain the task ID of the workflow task that was launched.

An example:

```
<?xml version="1.0" encoding="UTF-8"?>
<message>
  <response>taskid=dd145a15-49bb-4625-a0da-6d3aee663ae3</response>
</message>
```

- In case the workflow could not be launched successfully and/or an error occurred, the HTTP response will contain one or more error messages.

An example where the workflow ticket could not be found:

```
<?xml version="1.0" encoding="UTF-8"?>
<message>
  <error>
    <code>-110</code>
    <msg>Problem loading ticket: swft/Web Service Access Point Test WF</msg>
  </error>
</message>
```

### Synchronous Communication Responses

The response depends on what the workflow created:

- When the workflow task created one file, it will return that one file. An example of such a response where one PDF was created (see the response header as captured from a browser's "network traffic" view after launching the call from that browser):

▼ Response headers (0.116 KB)
Content-Length: "18476"
Content-Type: "application/pdf;charset=UTF-8"
Server: "Jetty(7.4.2.v20110526)"

- When the workflow task created multiple files, it will return a MIME file containing them. An example of such a response:

▼ Response headers (0.172 KB)
Content-Type: "multipart/mixed; boundary="-----_Part_17_1327725136.1464012269088";charset=UTF-8"
Server: "Jetty(7.4.2.v20110526)"
Transfer-Encoding: "chunked"



- When the workflow task did not create any output files (in an OK status), the response mentions this as a remark:

```
<message>
  <response>taskid=def75756-ad52-42ac-829e-93a7a90d2741
    <remark>WorkFlow produced no OK-outputs.</remark>
  </response>
</message>
```

## 24.3.10. Job Sharing Access Point

This type is described in the chapter "[Sharing to Collaborate with other AE servers](#) on page 1685".

Find a direct link [here](#).

## 24.3.11. Cloud Storage Access Point

### Concept and Generic Options

#### Concept

A cloud storage access point scans a folder in "the cloud" and downloads (moves) any new files that appear in that folder or its subfolders onto a folder inside an Automation Engine Container. The downloaded files are removed from the cloud storage. The access point can also start a workflow on those files.



**Note:** There is also a [task that can upload data from within an AE Container to such a cloud storage folder](#).



**Attention:** Windows' "reserved characters" are not supported, nor in the name of the destination folder nor in the names of the files that you download. Learn more [here](#).

Automation Engine supports these cloud storage providers: [Box](#), [Google Drive](#), [OneDrive](#) and [Amazon S3](#).

Before you can use such an access point, you need to [configure one or more account authorizations in the Configure tool](#).

#### Generic Options

We here illustrate the options that most providers have in common. Any specifics per provider are mentioned in their dedicated pages hereafter.

- The first steps to create a cloud storage access point are very similar to creating any other access point. See an example of the detailed steps in [the first 5 steps of this page](#).
- In the **Settings** tab of the provider:
  - **Account.** Choose an account from the list that you first added in [the Configure tool](#). Only the accounts for the selected provider are shown. Click **Configure** to see or create that configuration.

- **Folder.** By default, this is the account's home directory. Remember that subfolders of the specified folder are also scanned. When you do not want all these folders scanned, you can specify a subfolder, for example "/PrePressData". Then, only all data in that folder and its subfolders will be scanned.

Learn more below about options to use or replace (parts) of this path in the destination path.

- In the tab **Monitoring:** These options are identical to those explained [here](#).
- In the tab **Automatic Actions:** Downloaded files with a same name are overwritten. The options are identical to those explained [here](#).

### Creating and Copying of Folder Names

In many cases, not just the name of the file is interesting, but also the place where it was stored in the cloud storage. It might therefore be useful to re-use (parts of) that folder structure on the Automation Engine container. The folder names can also contain many other forms of information: their name might reflect the customer name, job order ID, production category, etc.

An example: we assume the following situation and then illustrate several possibilities in the below table:

- On the cloud storage, the home directory of the used account contains " SuperBeer/bottle/blond33.pdf "
- We want to move the new found files onto " file://AEServer/Data1/FromTheCloud".
- You can use "/@-<number>" to specify how many cloud storage folder levels you do *not* want to copy from the cloud path onto the new one. To make sure you do not copy any parts at all of the cloud path, you can for example enter "/@-99".

**Table: Different cases based on above example:**

"Folder" in the tab "<provider> Settings"	"Move Files To" in the tab "Automatic Actions"	Result
empty or "/"	file://AEServer/Data1/FromTheCloud	file://AEServer/Data1/FromTheCloud/SuperBeer/bottle/blond33.pdf
"/@-1"	file://AEServer/Data1/FromTheCloud	file://AEServer/Data1/FromTheCloud/bottle/blond33.pdf
"/@-2"	file://AEServer/Data1/FromTheCloud	file://AEServer/Data1/FromTheCloud/blond33.pdf
"/@-2"	file://AEServer/Data1/FromTheCloud/ [First Folder of File]	file://AEServer/Data1/FromTheCloud/SuperBeer/blond33.pdf
"/@-2"	file://AEServer/Data1/FromTheCloud/ [Folder of File]	file://AEServer/Data1/FromTheCloud/bottle/blond33.pdf



**Note:** Above example is also valid for the FTP and SFTP access points.

## Google Drive Access Point



The options for a [Google Drive](#) access point are identical to those for the other cloud storage providers. Learn more in the section [Generic Options](#).

## OneDrive Access Point



The access point options for a [OneDrive Personal](#) or a [OneDrive For Business](#) access point are identical to those for the other cloud storage providers.

Learn more in the section [Generic Options](#) on page 1803.

These 2 types of OneDrive storage applications do have different requirements when it comes to the [configuration of their account](#).

## Box Access Point



The options for a [Box](#) access point are identical to those for the other cloud storage providers.

Learn more in the section [Generic Options](#) on page 1803.

## Amazon S3 Access Point



Many options for an [Amazon S3](#) access point are identical to those for the other cloud storage providers. Learn more in the section [Generic Options](#) on page 1803.

The tab '**Amazon S3 Settings**' contains an extra option '**Bucket**'. This is Amazon's term for "root folder".

- **Bucket:** This is a mandatory field to define the root folder. All subfolders will be scanned, unless you define another folder in the option below. Example: `Pharmadata.Chicago.Superprint`.
- **Folder:** When you here specify a folder (one that resides in the **Bucket** defined above), then that is the one will be scanned (and all it subfolders).

### 24.3.12. SAP Access Point

The **SAP** access point and the **Interact with SAP** task serve to integrate with an ERP system from [SAP](#). Such integrations are managed through assistance from [Esko Solution Services](#).

### 24.3.13. Agent Folder Access Point

This type is only available in an Automation Engine SaaS setup.

It is described in the chapter [AE SaaS: When your AE is in a Data Center](#) on page 1633.

Find a direct link [here](#).

## 24.4. Upload tasks

---

These tasks enable to upload data from within an Automation Engine Container to an FTP site or to a cloud storage (application).

Before you can use these, you need to configure their connection in the [Configure tool](#).

### 24.4.1. Task 'Upload via FTP'

This task allows to upload files to a folder on an FTP server. You need to have an FTP account on that server. You can use the task to send the files to more than one FTP location.

1. In the task ticket, click **New...** to define a location. The **Edit FTP Location** dialog pops up.

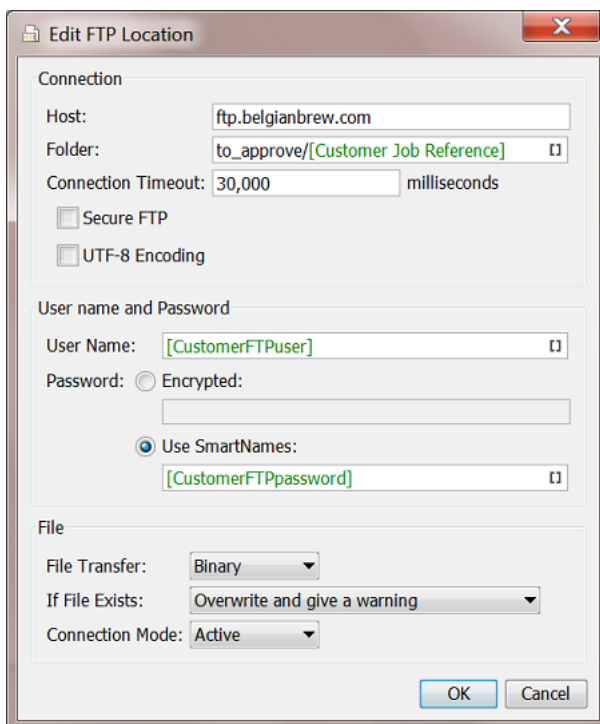

**2. Connection:**

- **Host:** the name of the server you want to send your files to.



**Tip:** To use a port other than the default port, add : and the port number after the host name. For example: myftpserver:1085

- **Folder:** Specify a FTP folder. When this field is empty, the files will be stored on the default directory.



**Tip:** Using SmartNames to help you to organize the arriving data.

- **Connection Timeout:** (By default 30.000 milliseconds). You only need to increase this value if you are working on a slow network and keep getting time out errors.

- **Secure FTP:** Select this if you are connecting to a secure FTP server (over FTPS)



**Tip:** If you are experiencing problems using secure FTP, try connecting over regular FTP, and ask your IT administrator to check the security settings of your FTP server.



**Tip:** FTPS (secure FTP) is the FTP protocol on top of SSL (similar to how HTTPS is the SSL secure version of HTTP). Do not confuse FTPS with SFTP, which uses SSH (secure shell). [Uploading files via SFTP](#) is therefore a different task, which is more reliable and can also solve issues with firewalls.

- **UTF-8 Encoding:** Select this to avoid encoding problems in file names. For example when sending French file names to a Chinese FTP server.

**3. Enter the User name and password** that allows you to connect to that FTP server:



**Tip:** To avoid that you have to change this ticket every time the password (and user name) changes, it might be useful to use SmartNames. This help for example when the user name and password is stored centrally and when SmartNames can retrieve their value via an [SQL query](#).

**4. File uploading settings:**

- **File Transfer:** Binary will always work, but if the file(s) you send are ASCII file(s), then the transfer will go a bit faster when selecting ASCII.
- **If File Exists:**
  - **Overwrite and give warning:** The file will be overwritten, but the tasks finishes in the state `Warning`.
  - **Overwrite:** This will just overwrite the file and the tasks finishes OK.
  - **Generate a unique file name:** This will append the task ID to the file name, and store the file at the destination under its unique name.
  - **Generate an error:** The file will not be sent, the task will fail.
- **Connection Mode:** By default, the transfer uses **Active** connection mode (where the FTP server opens the data connection).

When your system is behind a firewall that blocks incoming FTP server connections, select **Passive** connection mode (where the client initiates the connection).

## 24.4.2. Task 'Upload via SFTP'

### Concept

This task uses SFTP to upload files from within an Automation Engine Container to a folder on a host that runs an SSH-Server. When a file already exists on the destination folder, it is overwritten.



**Note:** IT security may require that you use this protocol i.s.o. [FTP\(S\)](#). Learn more in this [online article describing the difference between FTPS and SFTP](#).



**Attention:** The task takes care of the client side. Esko does not provide information on how to set up an SSH server.



**Note:** SFTP is often used to send files to a Mac OS computer.

### Settings

- **Server:** Select a configured SFTP server. Click **Configure...** to open the [SFTP sites topic in the Configure panel](#).
- **Folder:**
  - When you leave this field **empty**, the files will be sent to the user's home directory.

- When you here specify a folder name, the SFTP server will see it as a **subfolder** of the user's home directory (for most SFTP servers, a folder has to be specified relative, so a `./` is enforced, automatically added).
  - Use a slash to define extra subfolder(s). For example `FromAE/pharma1` or include `SmartNames: FromAE/[Date]/[Job ID]` or `FromAE/[Date]/[Folder of File]`.
- To specify the **exact folder** name, add the characters `@L` in front of the name. This instructs the SFTP server to take the folder field literally. For example:

When you specify this folder name:	the SFTP server will interpret it as:
inbound	<code>./inbound</code>
<code>@L/inbound</code>	<code>/inbound</code>



**Attention:**

- *Windows' "reserved characters"* are not supported, nor in the name of the destination folder nor in the names of the files that you upload. See their list [here](#).
- Non ASCII characters (ASCII = a-z, A-Z, 0-9) are only supported if the SFTP server you are uploading to supports UTF8 encoding.
- When the task is canceled, the task continues uploading the current file but does not start uploading the next input file.
- Files with a size greater than 150 MB can not be uploaded reliably.

- **If Folder Does Not Exist:** When the destination folder does not exist,
  - select **Create Folder** when you want to have it created. The same happens when you **Select a SmartName** that returns the value "1".
  - select **Task Fails** to not have it created and end the task in error. The same happens when you **Select a SmartName** that returns the value "0".

### 24.4.3. Task 'Upload To Cloud Storage'

This task uploads files from within an Automation Engine Container to a folder on a cloud storage service (Box, Google Drive or OneDrive).



**Attention:** This task does not upload to Esko Cloud. Learn about the dedicated tasks and tools in the chapter [Sharing to Collaborate with other AE servers](#) on page 1685 and in the chapter on [AE SaaS](#).

**Settings**

- **Account:** Select the cloud storage account that you configured earlier. Click **Configure...** to access [that item in the Configure tool](#).
- **Region:** We advise to specify a region. When none is specified, a search is done anyway but this can take some time. Note that in the [Configure tool](#) you can specify a **Default Region** indicating that all your buckets are within this same region anyway. In the task ticket, it's name will appear in grey text.

The task will fail when the bucket is not found in the specified region.

- **Bucket** (Amazon S3 only). This is a mandatory field to define the root folder. All subfolders will be scanned, unless you define another folder in the option below. Example: `Pharmadata.Chicago.Superprint.`
- **Folder**: Define the folder where you want to upload the files.

When you leave this field empty, the files are uploaded to the account's home directory.

When you specify a folder, it will be a subfolder of the account's home directory. Use a slash to define extra subfolder(s), for example `FromAE/pharma1` or include `SmartNames: FromAE/[Date]/[Job ID]` or `FromAE/[Date]/[Folder of File]`.



**Note:** This implies that these cases are not supported:

- uploading towards special folders (Music, Pictures, Documents)
- uploading to another OneDrive that this user has access to
- uploading to some sharing URL or default drive of some SharePoint site.



**Note:** (Amazon S3 only): When you here specify a folder (one that resides in the **Bucket** defined above), then that is the one that will be scanned (and all it subfolders).



**Attention:**

- This path needs to *URL encoded*. *Windows' "reserved characters"* are not supported, nor in the name of the destination folder nor in the names of the files that you upload. These characters are
  - <(less than)
  - >(greater than)
  - :(colon)
  - "(double quote)
  - /(forward slash)
  - \ (backslash)
  - |(vertical bar or pipe)
  - ?(question mark)
  - \*(asterisk)
- When the task is canceled, the task continues uploading the current file but does not start uploading the next input file.





**Attention:** When you upload a same file again to the same folder, the result depends on the type of cloud storage application:

- **Google Drive**
  - A new version is added.
  - The 'Modified' date is the date of the uploaded file.
- **Box**
  - A new version is added.
  - The 'Modified' date is the date of uploading.
- **OneDrive and Amazon S3**
  - The newly uploaded file overwrites the old file.
  - The 'Modified' date is the date of uploading.

- **If Folder Does Not Exist:** When the destination folder does not exist,
  - select **Create Folder** when you want to have it created. The same happens when you **Select a SmartName** that returns the value "1".
  - select **Task Fails** to not have it created and end the task in error. The same happens when you **Select a SmartName** that returns the value "0".

## 24.5. Data Transforming Tasks

---

We introduced the concept of these tasks in the chapter [AE Mapper tasks Transforming Data](#) on page 1774.



**Attention:** These types of tasks require good knowledge of SmartNames.



**Attention:** The **XPath Builder** makes it a lot easier to extract parts from XML files. This tool is documented in a [separate chapter on SmartNames](#).

### 24.5.1. Task 'Convert JSON to XML'

#### Concept

JSON stands for 'JavaScript Object Notation'. Learn more on <https://en.wikipedia.org/wiki/JSON> or <http://www.json.org/fatfree.html>.

When Automation Engine is to *receive* information from a web service, that application may prefer to directly send JSON data to Automation Engine in stead of first converting it into the more generic XML format.

The JSON file could be of the JSON 'Object' type or of the JSON 'Array' type. This task can convert such JSON data into corresponding XML data, the format that Automation Engine has many tools for.



**Note:** When Automation Engine needs to *send* data to a web service, it can also convert XML data to JSON data. Learn more in [Task 'Convert XML to JSON'](#) on page 1813.

### JSON sample

- **JSON Object:** An 'object' starts and ends with '{' and '}'. Between them, a number of string value pairs can reside. String and value is separated by a ':' and if there is more than one string value pair, they are separated by ','.

Syntax:

```
{ key: value, .....}
```

Example:

```
{ "companyName": "Esko", "location": "Bangalore", "email":"admin@esko.com" }
```

In JSON, objects can nest 'arrays' (which start and ends with '[' and ']') within it. An example:

```
{ "Companies": [{ "Name":"Esko" ,"Location":"Bangalore" },
{ "Name":"Danaher" ,"Location":"US" } ] }
```

- **JSON Array:** An 'array' starts and ends with '[' and ']'. Between them, a number of values can reside. If there is more than one value, they are separated by a ','.

Syntax:

```
[ value, .....]
```

An example:

```
[
  { "name": "Bidhan Chatterjee", "email": "bidhan@example.com"},
  {"name": "Rameshwar Ghosh","email": "datasoftonline@example.com"}
]
```

### Task Options

- **Root Element Name:** Specify the name of the root element in the output XML. The default value is "ROOT".
- **Array Element Name:** Specify the element name for each JSON array item in the output XML. The default value is "ARRAY\_ITEM".

The task will fail when the input XML file is not well formed.

The task automatically adds an extension `.json` to the output file. The output file will be in UTF 8 format.

### Workflow Example

There are several examples when Automation Engine can get a response from a web service in JSON format.

One of them is the [Interact with Web Service task](#). Its JSON output can so be converted to XML.



Also a [Web Service Access Point](#) could bring such JSON data.



**Tip:** With that type of Access Point, it might be enough to type an inline JSONPath expression to extract some (workflow) parameters. Learn more in [JSONPath Expressions](#) on page 810.

### Conversion Example

See how the JSON (left) was converted to XML (right):

<pre> {   "company_list":{     "company":{       "zip":233244,       "country":"Hindustan",       "Type_Code":"Type_COde",       "Location_Name":"Bangalore",       "address2":"#14- Esteem tower, railway road",       "city":"chennai",       "phone":9625342772,       "address1":"Shivajinagar",       "Company_Name":"001_Insert_Company_With_Smartname",       "state":"JH",       "fax":38469,       "Company_Number":"Esko"     },     "type":"Yes",     "delete":"No",     "key":"Company Name"   } }         </pre>	<pre> &lt;company_list&gt;   &lt;company&gt;     &lt;Company_Name&gt;001_Insert_Company_With_Smartname&lt;/Company_Name&gt;     &lt;Company_Number&gt;Esko&lt;/Company_Number&gt;     &lt;Type_Code&gt;Type_COde&lt;/Type_Code&gt;     &lt;Location_Name&gt;Bangalore&lt;/Location_Name&gt;     &lt;address1&gt;Shivajinagar&lt;/address1&gt;     &lt;address2&gt;#14- Esteem tower, railway road&lt;/address2&gt;     &lt;city&gt;chennai&lt;/city&gt;     &lt;state&gt;JH&lt;/state&gt;     &lt;zip&gt;233244&lt;/zip&gt;     &lt;country&gt;Hindustan&lt;/country&gt;     &lt;phone&gt;9625342772&lt;/phone&gt;     &lt;fax&gt;38469&lt;/fax&gt;   &lt;/company&gt;   &lt;key&gt;Company Name&lt;/key&gt;   &lt;type&gt;Yes&lt;/type&gt;   &lt;delete&gt;No&lt;/delete&gt; &lt;/company_list&gt;         </pre>
-------------------------------------------------------------------------------------------------------------------------------------------------------------------------------------------------------------------------------------------------------------------------------------------------------------------------------------------------------------------------------------------------------------------------------------------------------------------------------------------------------------------------------	--------------------------------------------------------------------------------------------------------------------------------------------------------------------------------------------------------------------------------------------------------------------------------------------------------------------------------------------------------------------------------------------------------------------------------------------------------------------------------------------------------------------------------------------------------------------------------------------------------------------------------------------------------------------------------------------------------------------------------------------------------------------------------------------------------------------

## 24.5.2. Task 'Convert XML to JSON'

### Concept

JSON stands for 'JavaScript Object Notation'. Learn more on <https://en.wikipedia.org/wiki/JSON>.

When Automation Engine is to send information to an external web service, that application may prefer to receive JSON data in stead of XML.

This task can convert XML into corresponding JSON data.



**Note:** When Automation Engine is *receiving* JSON data from an external web service, it can also convert JSON to XML. Learn more in [Task 'Convert JSON to XML'](#) on page 1811.

### Task Options

- **Keep all values as strings:** When selected, all element values will in the output files be kept as strings (and thus provided in quotes).

### Workflow Example

A typical workflow would be to convert XML to JSON right before sending it to the external web application (using the [Interact with Web Service task](#)):

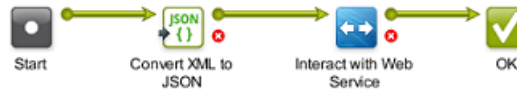

### 24.5.3. Task 'Create XML File'

The **Create XML File** task is typically used to export value from SmartNames to an external system.



**Important:** This task does not use its task input file to start building the XML from. The content of the XML that you will create is completely defined inside the task window.

#### Defining the content of the XML

The **Create XML File** task offers a blank canvas where you need to define all the content of the XML that you want to create. In below example you see a combination of self written XML code (blue) and some SmartNames (green). Click on **+ [ ] insert SmartName** to pick a SmartName from the list. Alternatively, right-click and choose a SmartName from the offered categories.

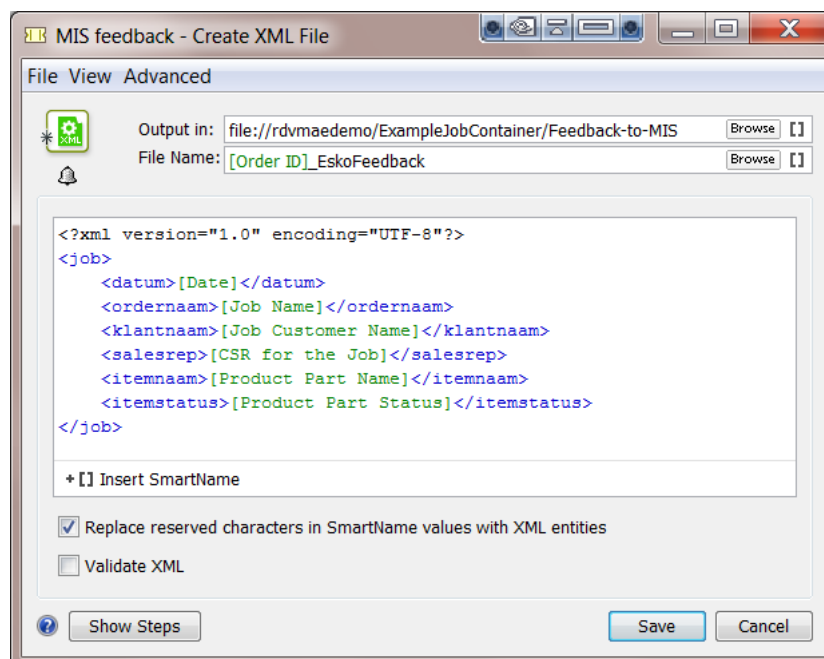

**Note:** The XML file has to start with an XML declaration. This line indicates the file encoding to the reading application. To add such a line, you can simply right-click and choose **Insert XML Declaration** to insert this industry default one: `<?xml version="1.0" encoding="UTF-8"?>`



**Note:** Any links to externally defined XML schema (for example a reference to a DTD or XSD) may influence performance. Preferably remove such links from the XML file.

- **Replace reserved characters in SmartName values with XML entities:** It is possible that the SmartName returns characters that are not allowed in XML. With this option, you choose to map these special characters mapped into these 'XML entities'. Below list shows these mappings:

Reserved characters in result value	Meaning	XML Entities
"	quotation mark	&quot;
'	apostrophe	&apos;
&	ampersand	&amp;
>	greater than	&gt;
<	smaller than	&lt;

- **Task fails when output XML is not a valid XML file :** Enable this option to have Automation Engine check the validity of the XML. If this option is on, the task will fail if the XML is not valid. The validation checks the XML formatting and the XML tag endings.



**Note:** This task does not check XML schemas such as XSD, DTD, etc.

## 24.5.4. Task 'Map Data'

### Concept

The **Map Data** task is a powerful tool that can be used to

- convert CSV files into XML and vice versa.
- transform the content of a CSV or XML file: extract, join, rename or re-format parts.



**Note:** A CSV or comma separated file is a structured text file. In such files commas or some other character are used as field separators. CSV can be generated by exporting an XLS file in Microsoft Excel.

Some example use cases:

- After interacting with an external system, you need to simplify or re-write the XML files that you received.
- You need to combine information from different sources into 1 file, but also reformat it (this is more than what the **Join XML** task can do). For example getting job specification from an incoming XML file and getting ink information from the metadata of an uploaded PDF (XMP). You want to combine those into one XML that can be used for the **Job Creation** task. To do this, the XMP ink information should also be transformed to the XML format that is needed for **Job Creation** task.
- You need to transform an XML that you received before it can be used by the **Create CAD Sheet** task.
- You receive an XML file with all possible sheet layouts. Now you need to create a list of these layouts using a custom text format (for example plain text with line breaks, CSV or XML).



**Tip:** The chapter [Examples](#) on page 1858 contains many examples that use this task.

### Main Tools in the Task Panel

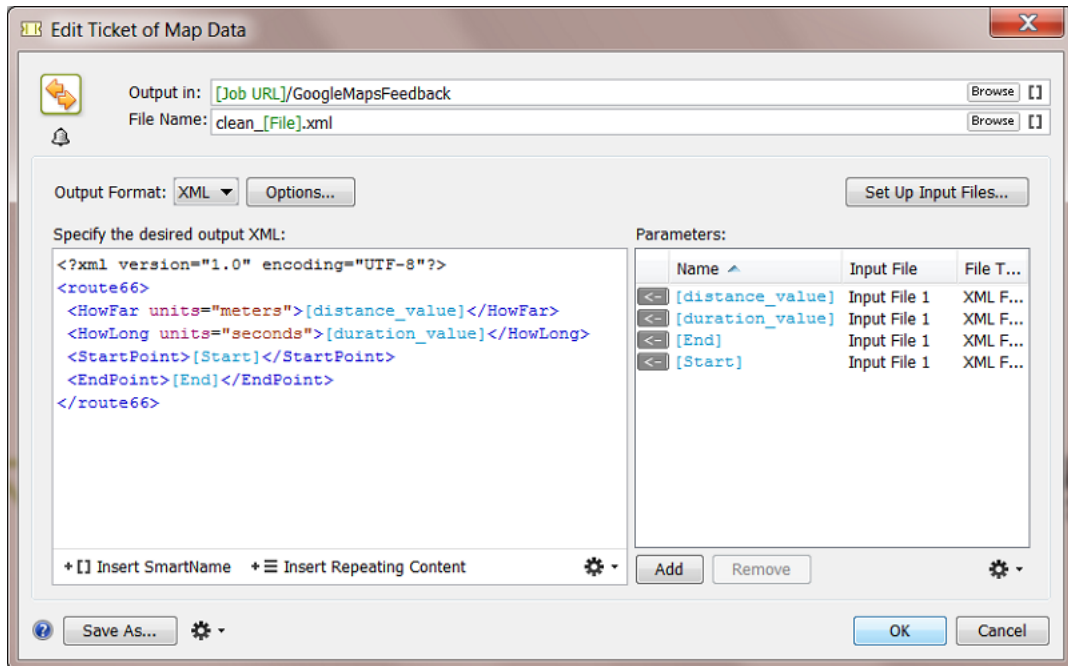

The **Map Data task** panel consists of three main parts:

1. Option to choose the Output Format.
2. Canvas to specify the content of the output file of this task.
3. List of Parameters that you want to read from the task's input files.

### Choose the Output Format

- **XML:** Click on **Options** to define these output format options:
  - **Replace reserved characters in parameter values with XML entities:** It is possible that the parameters from the input files return characters that are not allowed in XML. With this option, you choose to map these special characters to 'XML entities'. Below list shows these mappings:

Reserved characters in result value	Meaning	XML Entities
"	quotation mark	&quot;
'	apostrophe	&apos;
&	ampersand	&amp;
>	greater than	&gt;
<	smaller than	&lt;

- **Task fails when output XML is not a valid XML file:** Enable this option to have Automation Engine check the validity of the XML. If this option is on, the task will fail if the XML is not valid. The validation checks the XML formatting and the XML tag endings.



**Note:** This task does not check XML schemas such as XSD, DTD, etc.

- **CSV:** Click on **Options** to define this Output Format option:
  - **Text Encoding:** Choose what type of text encoding that the system that will read this CSV file prefers. The default is UTF-8.

### Canvas to Specify the Content of the Output file

The canvas on the left there is where you can

- insert XML or CSV data from another file. This is the typical way to insert your example output file, after which you can start replacing its absolute values with SmartNames or Parameters.
- insert Parameters from your input files (from the list on the right side of the panel)
- insert SmartNames
- insert XPath expressions (the standard language to extract specific parts of an XML)
- ...

See more in [Specifying the Output File](#) on page 1822.



**Tip:** Right-click in the canvas to get a list of content to insert.

### A List of Parameters from your Input Files

In this field, you build up a list of parameters from your input files. You can then insert these parameters easily in the canvas on the left, similar to how you insert SmartNames. These parameters can come from one or more input files.

At the moment you set up the Map Data task, it is good practice to use *example* input files that contain the same parameters as the files that will be the *real* input files of the Map Data task once it is started in a workflow. It is also a good idea to start from a sample output file (see further).

See more in [Setting Up \(Example\) Input Files](#) on page 1818 and [Adding Parameters](#) on page 1820.

### Main Workflow in Using the Map Data Task

Before we go in more detail explaining all the possibilities of this powerful task, it is good practice to stick to following main workflow:

- Step 1: Get an example of the output file you need to create. Analyse its structure.
- Step 2: Get (an) example input file(s). Analyse its structure.
- Step 3: Create the parameters from the input file(s).
- Step 4: Specify the output file. Use your example output file and the parameters that you made from the input file(s).
- Step 5: Test the resulting ticket in a workflow, using real input files.

## Setting Up (Example) Input Files



**Attention:** An example input file is a file that you use while you set up the **Map Data** ticket. Be aware that this example file is often not your real input file once the task is running!



**Important:** The **Map Data** task allows to create parameters *without* the help of example input files but this will be much more complex. We advise to create the parameters based on example input files because it will help you with correct spelling, see the larger context and give you immediate feedback.

### 2 ways to select an Input File

- In the **Pilot**, select one or more input files **before** you open the **Map Data** ticket. These files will show up as input files.
- Open the **Map Data** ticket and click on **Set Up Input Files....**

Setting up an **Input File** is explained in more detail in the next sections of this document.

### Working with Multiple Task Input files

By default a **Map Data** task will start as soon as it gets one input file. The task will not wait for a list of input files to be complete. But you can easily solve that.

To make the **Map Data** task work on multiple input files, you need to make a workflow where you have a **Data Collector** task before your **Map Data** task.



The **Data Collector** task will wait for outputs of previous tasks and hand them over as one group to the next task.

### How to Control the Order of Multiple Input Files

If your **Map Data** task has more than one input file, it is very important to control the order of those input files. What you want to avoid is

- parameters that do not find their value because they look in the wrong input file.
- parameters that find a value but one that comes from the wrong input file.

Some examples that illustrate the importance of parameters looking in the correct input file:

- Your **Map Data** ticket is part of a workflow that creates a new **Job**. Does the parameter [date] or [time] come from the input file from the MIS or from the metadata-XML from the PDF that the customer sent you? The difference can result in a conflict about your due date of that **Job**!
- Your parameter [print technique] selects the field in row 2, column 5 of a CSV file. If this parameter searches this field in the wrong input file, then your search can return "Rio de Janeiro" instead of "Digital Flexo"!

To control the order of your input files, we advise to first use the **Data Collector** task, followed by a **Sort** task and only then followed by the **Map Data** task.





The **Data Collector** task will wait for outputs of previous tasks and hand them over as one group to the next task.

The **Sort** task enables you to sort that group. You can base the order on file name, time or SmartNames.

### Setting up (Example) Input Files - Details

1. Click on the **Set up Input Files...**

A panel opens that shows your current list of Input Files, their name and order in the list, their type (XML or CSV) and if they link to an example file or not.

2. To add or modify one, click on **Add** or double click an existing Input file definition.

The **Set Up** panel opens.

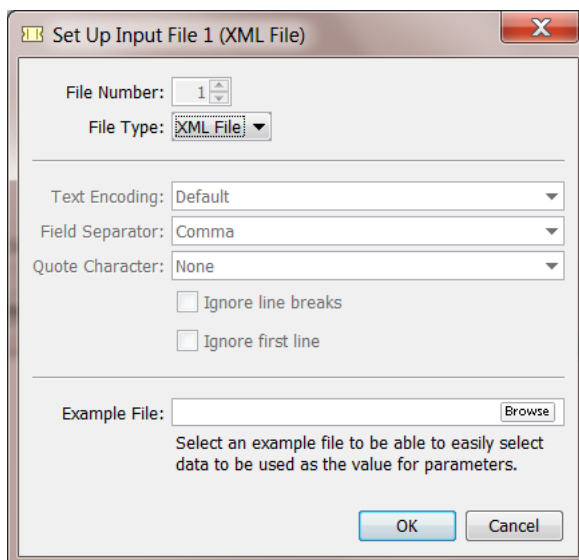

3. Choose the **File Type** of the desired Input File: **XML File** or **CSV File**.

4. In case you chose **CSV File**, you can change the following CSV options:

- **Text Encoding:** Indicate the **Text Encoding** of the CSV file. The default encoding is Unicode UTF-8.
- **Field Separator:** Indicate which character is used to separate the fields in the CSV. Check your CSV in a simple text editor to detect it.
- **Quote Character:** Indicate if the value in the CSV contains quotes that you do not want to keep. For example: In the CSV the value is written as "25000" but you want to extract only the 25000.
- **Ignore line breaks:** Check this option if the CSV only contains one record (column).

- **Ignore first line:** Check this option if the first line of the CSV contains the names of the columns.



**Note:** These CSV options have a great impact on the way the CSV input files are handled. A selected value field (using the field number and the line number of the field) can be the wrong one if the CSV options are not set correctly.

5. If you want, select an example file to be able to easily select data to be used as the value for parameters.

### Removing an Input file

In the **Set Up Input files** panel, the **Remove** button will remove the selected input file.

When there are no parameters created yet that use that input file, the input file item will be removed. You will not be asked to confirm.



But when the input file is in use, you will see a warning mentioning this use. You will be asked to confirm before deleting the input file item together with all the parameters or 'repeating content' that require that input file.



**Note:** A similar warning and effect happens when you change the *File Type* of the Input file (from XML to CSV or vice versa).

### Adding Parameters

There are basically 3 ways to create new parameters:

- creating them one by one, using the **Add** button.
- loading **multiple** parameters from a file, using the  button.
- duplicating an existing parameter, using the  button.

### Adding Parameters

Once you specified the output format and set up the (example) input files, you can start adding parameters that represent the values that you wish to insert from the task's input files into the output file.

To add parameters, proceed as follows:

1. Click **Add** underneath the **Parameters** list.  
The **Add Parameter** dialog prompts.
2. Enter a **Name** for the new parameter.
3. Select the **Input File** that contains the value for the parameter.
4. Specify where the value for the parameter is located in the selected **Input File**:
  - In case you selected an XML **Input File**, specify the **XPath Expression** of the value in the input file to be used as the value for the parameter. If you selected an example XML file for the XML input file, you can easily create the **XPath Expression** using the **Edit** button. This will open the **XPath Builder**. For more information on **XPath Builder**, see [The XPath Builder](#) on page 678 (chapter 'SmartNames').

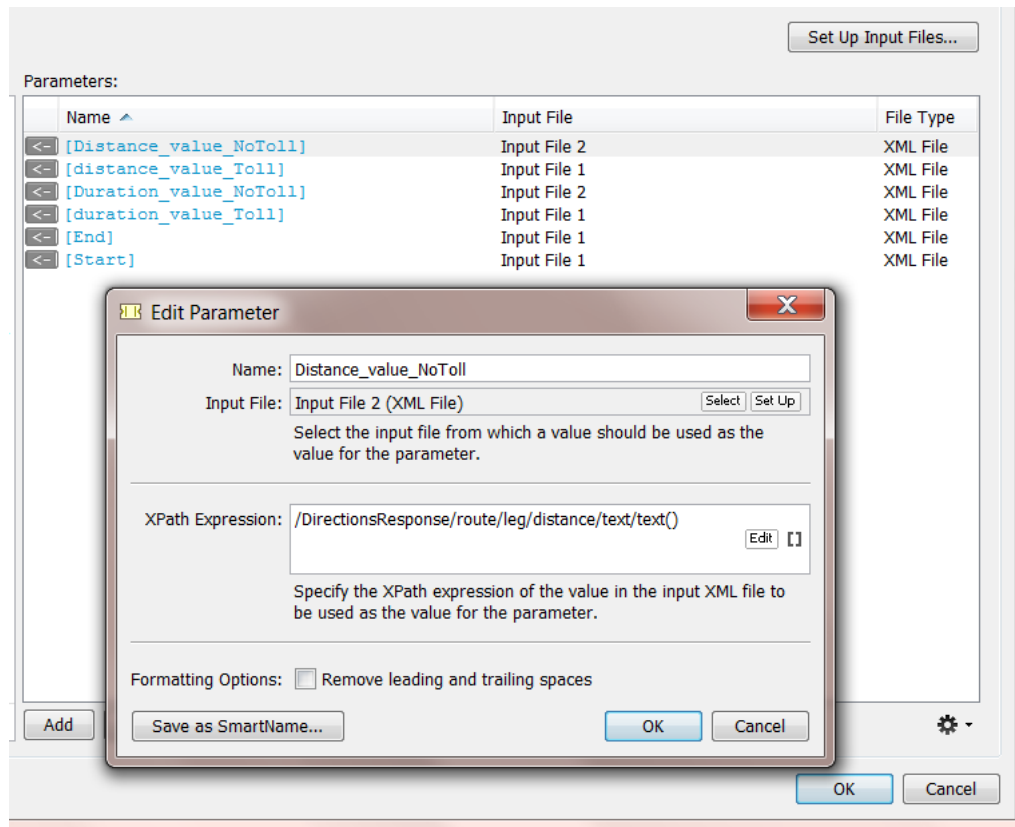

**Attention:** When the expression asks for the text node that contains no text (an 'empty node'), the task will fail ("ParseException").

- In case you selected a CSV **Input File**, specify the **Field** number and the **Line** number of the field in the input CSV file to be used as the value for the parameter. If you selected an example CSV file for the CSV input file, you can select the desired field using the **Select Field** button.
- 5. Separator.** If the XPath expression returns multiple elements, decide what character you want to be used as separator.
  - 6. Formatting Options.** If you suspect that the chosen value might have leading and/or trailing spaces, select **Remove leading and trailing spaces**.
  - 7.** If you want to save the created parameter as a SmartName, then click **Save as SmartName....** In the prompted dialog, enter a comprehensive **Name** and **Description** and choose whether or not you want this SmartName to be **Private**.
  - 8.** Click **OK** to add the parameter to the **Parameters** list.

The created Parameter is now in the **Parameters** list. You can now insert the created parameter in the output XML or CSV (see [Specifying the Output File](#) on page 1822).



**Note:**

- To edit an existing parameter, select it in the **Parameter** list and double-click it.
- To delete an existing parameter, select the parameter and click **Remove**. You will get a warning when you try to delete a parameter that is in use (in the canvas on the left).
- To delete all unused parameters, click on the action button  underneath the **Parameters** list and choose **Delete Unused Parameters**. You will be asked to confirm.
- To add Parameters from an example input file, see the next section.

### Loading Multiple Parameters from a File

Instead of creating parameters one by one, you can choose to load multiple parameters from a file. Those that you would not need are easy to remove from the list anyway. To do so, proceed as follows:

1. Underneath the **Parameters** list, click on the **Action**  button.
2. Choose **Load Parameters from File** in the prompted menu.  
The **Load Parameters from File** dialog will prompt.
3. **Select** the desired **Input File** from which you want to load the parameters.
4. If the selected **Input File** is an XML file, proceed as follows:
  - a) Specify the **XPath Expression** to load the XML parameters from the **Input File**. You can click **Edit** to open the Xpath Builder to help you build the desired **XPath Expression**.
  - b) Click **OK**.  
All parameters from the selected XML Element will be loaded, including child elements and all attributes
5. If the selected **Input File** is a CSV file, proceed as follows:
  - a) If the **First line contains parameter names**, select the similarly named option and the values from the first line will also become parameters.
  - b) Click **OK**  
CSV Parameters will now be added for every field of every record in the **Input File**.



**Note:** About names of parameters:

- When one or more parameters that are loaded from the example input file have the same name (because the XML element name, the XML attribute name or the CSV field name in the example XML/CSV file is the same), their names will be made unique by auto-numbering them.
- When one or more parameters with the same name already exist, a warning dialog will pop up asking you if you want to replace them or not. If you choose to replace them, this will overwrite their current contents.

### Specifying the Output File

The canvas on the left of a **Map Data** ticket is where you define what your resulting XML or CSV output file will contain.

There are many types of smart content that you can add to this canvas. And you can even type in some content yourself. Some of these types of content are listed via the  button. You will also see a complete list of possibilities when you right-click inside the canvas.



**Note:** Most of these are sensitive to the position of your cursor at the moment you right-clicked. They will not be offered when they are not valid at that specific insertion point.



**Attention:** There is no 'Undo' function while editing in this canvas.



**Tip:** Find a good [example](#) in the chapter [Examples](#) on page 1858. It shows how 2 XMLs from the application Google Maps are mapped into one smaller output XML. That output XML so contains only specific content to be picked up as workflow parameters.

Here are all the methods and data types that you can enter:

### Cut-Copy-Paste

These standard functions work on all types of data you have entered here.

### Clear Contents

This will clear the whole canvas.

### Insert SmartName

Your output XML can also contain SmartNames. This way you can add information to the XML that was maybe not present in the input files but important extra data for the system that will read the output file.



**Note:** You can also use the dedicated **+ [ ]** button.

### Paste from File...

The complete content of the selected file will be added here. This will be possible with all content that is in a format that can be output to XML or CSV.



**Important:** Use this function to paste your example output file.

### Insert XML Declaration

It is a good practice to have an 'XML declaration' at the start of your XML file. This line indicates the file encoding to the reading application. This feature will here insert the industry default one:

```
<?xml version="1.0" encoding="UTF-8"?>
```

### Insert XML Element

Type in the name of the **element** that you want to insert. An opening and closing statement of that **element** will be inserted. For example:

```
<Distance></Distance>
```

Often, you will continue by inserting a **Parameter** in between those two.

### Insert XML Attribute

Type in the name and value of the **attribute** that you want to insert. For example:



```
units="miles"
```

For example: see how this **attribute** was inserted in the above **element**:

```
<Distance units="miles"></Distance>
```

### Insert Parameter

Choose the parameter from the list. Alternatively, select the parameter in the parameter list on the right side and

- Click the  to insert that parameter at the current cursor position in the canvas.
- Drag & drop the  to the right position in the canvas.

For example: the parameter [GoogleMapsDist] was inserted in above example:

```
<Distance units="miles">[GoogleMapsDist]</Distance>
```

### Insert New Parameter

This is a shortcut that combines the adding of a new parameter with its immediate placement in the canvas. After you inserted this new one, it will also appear in the parameter list on the right.

### Avoiding Problems with some 'Velocity' Characters



**Attention:** The underlying technology of the Map Data task is [Apache Velocity](#). This task allows to build and execute so called 'Velocity templates'. This enables a very powerful tool, but also imposes some limitations.

Some characters in Velocity have a special meaning. For example \$ points to a 'variable', # to a 'directive'.

The task can handle such characters when they are entered via Map Data 'Parameters'. But if those characters appear in the fixed text of the template or in the resolved SmartName values, then the task may fail unexpectedly.

For example: The following desired output would make the task fail:

- ```
<job>
<separation value="ink#1">
</job>
```
- Or, in case a SmartName is used (where inkname would result in ink#1):

```
<job>
<separation value="<<inkname/>>">
</job>
```

To avoid this problem, you need to add # [ [ at the beginning and ] ] # at the end of the string that contains those special characters.

For example:

- ```
<job>
<separation value="ink#[[#]]#1">
</job>
```
- Or, in case of SmartNames:

```
<job>
<separation value="#[ [<<inkname/>>]]#">
</job>
```



**Important:** Esko's support and documentation on Velocity templates is limited to what is described in this manual.

## Inserting Repeating Content

Your output XML can include a block of repeating content that represents a repeating XML element in your XML input file. For example: for each book described in the input file, you want to pick up selected parameters like its author, category and price (see this example in below screen shots).

### Creating a Repeating Content Block

Make sure your cursor is at the correct place in the canvas and then right-click or use the dedicated **+≡** button. In the dialog, type the XPath expression that selects the repeating XML element in your selected **Input File** or click **Edit** to use the Xpath Builder.

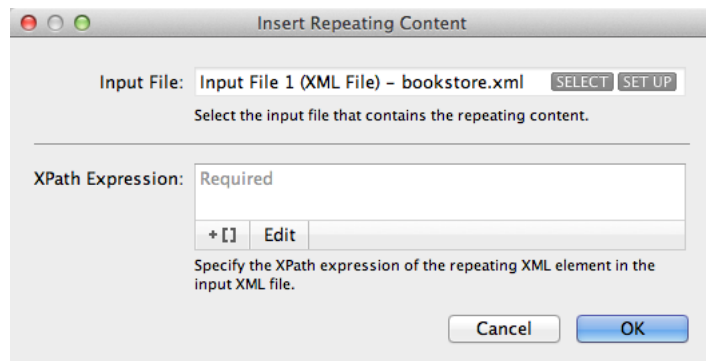

Click **OK** and see the repeating content block appear in pink. If you want, you can now manually add XML elements:

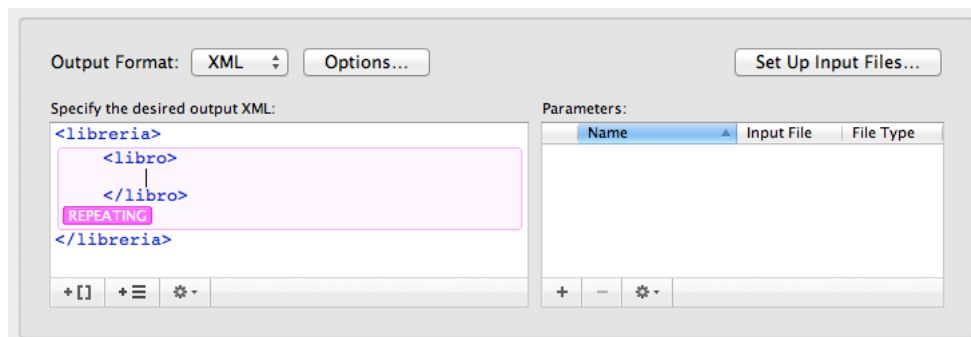

### Loading Parameters into a Repeating Content Block

You can now add parameters in the way we described [above](#). However, we here describe an optimized way that will avoid loading too many parameters that you may not need.

1. Place your cursor inside the repeating content block and select **Load Parameters from File...** from the  button under the list of **Parameters**.

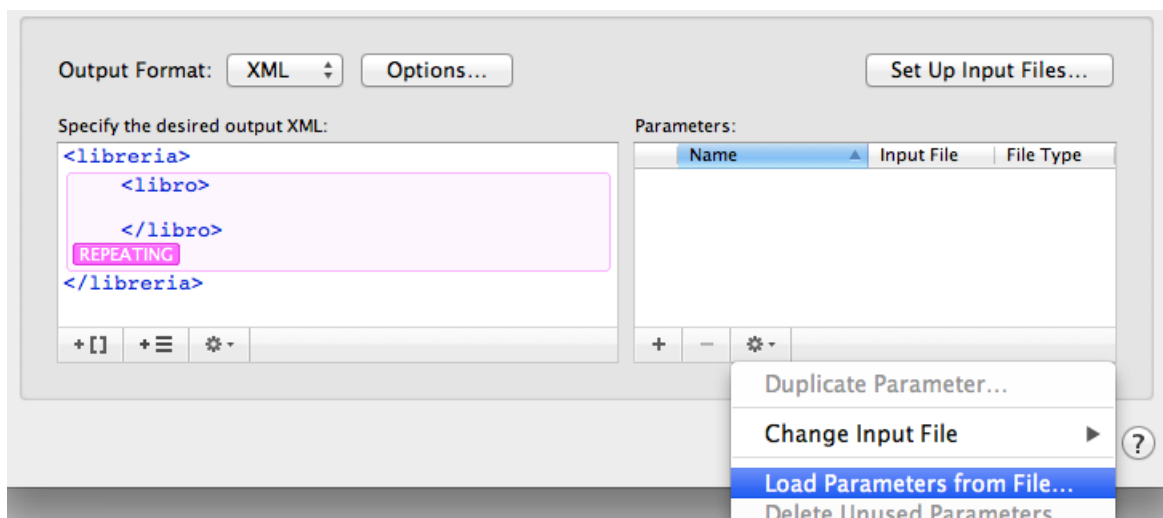



- In the **Load Parameters from File** dialog, you have a choice:

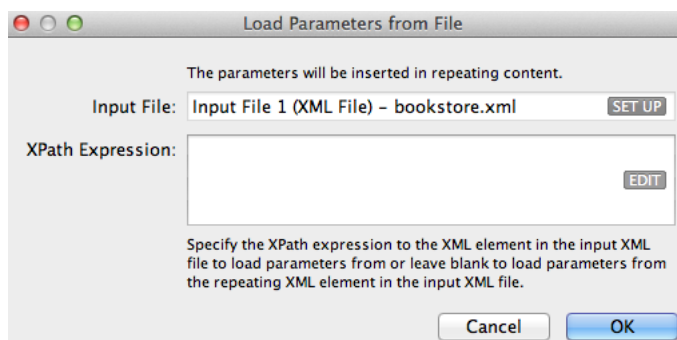

- You can specify an **XPath Expression** to an XML element inside the repeating XML element in the **Input File**. To do this, click **Edit** to open the Xpath Builder and there select the XML element.

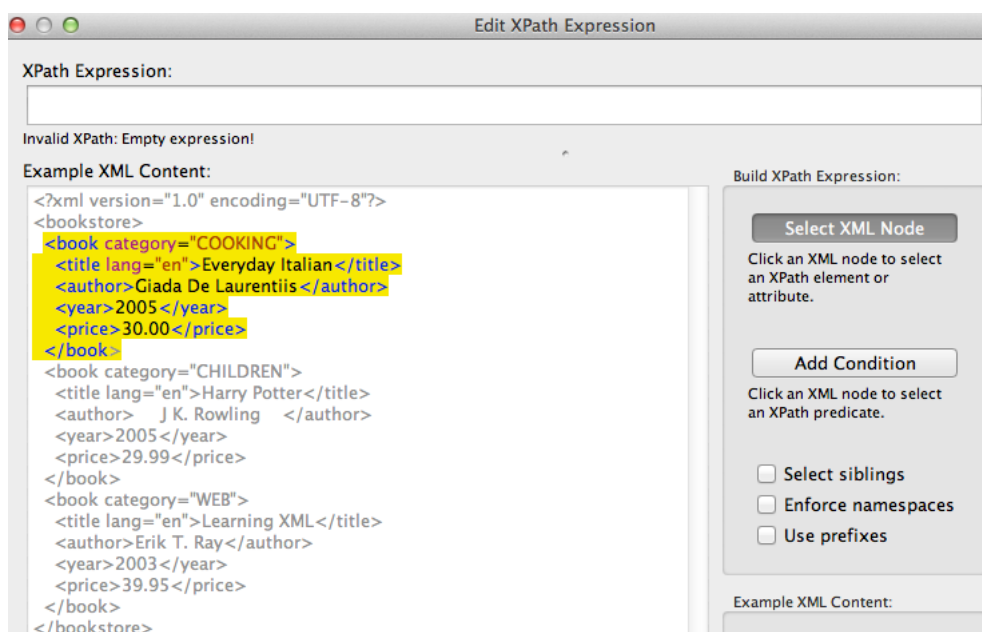

- Or you can choose to load all parameters from that repeating XML element. To do this, leave the **XPath Expression** field blank.
- Click **OK** in the **Load Parameters from File** dialog. This will add **Parameters** for every child XML element of the selected XML element and for all of their XML attributes. Their pink color indicates they can (only) be used for repeating content:

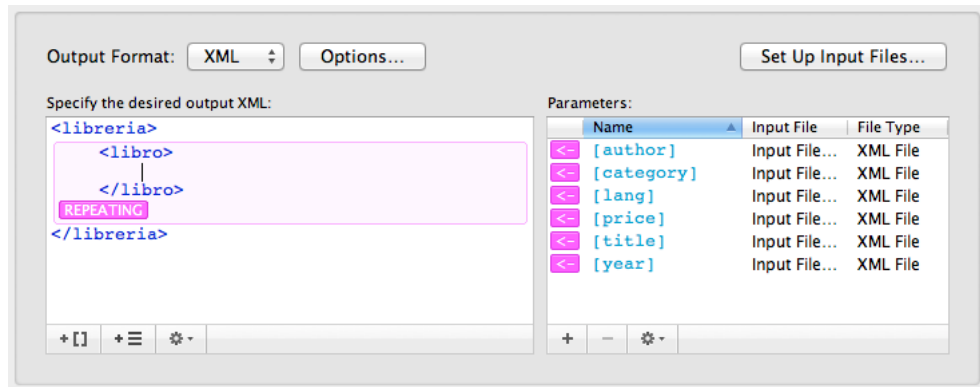

- Now build your repeating content block by positioning your cursor in between an XML element and clicking the pink arrow of a parameter. An example:

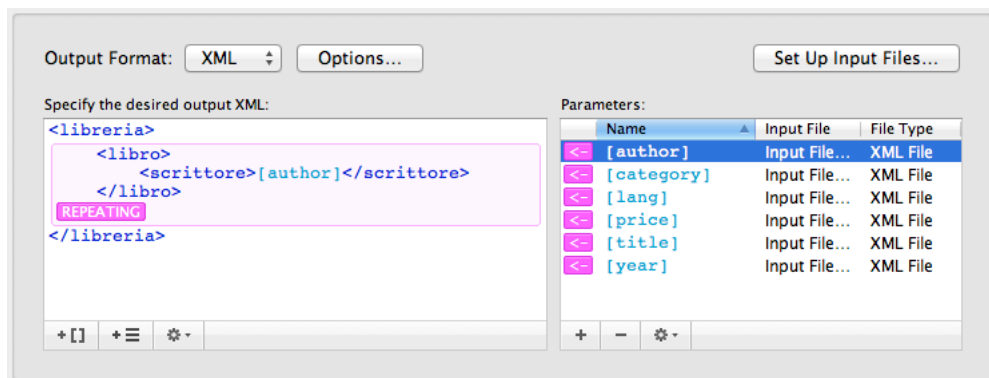

### Nested Repeating Content

It is also possible to insert repeating content inside another repeating content block. See this example:

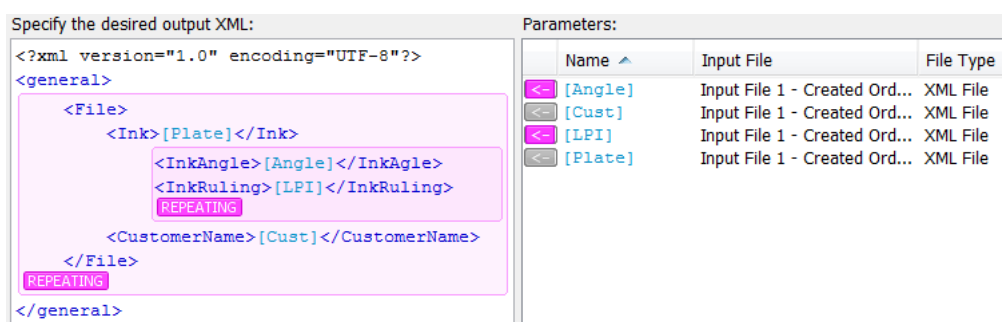

### 24.5.5. Task 'Join XML Files'

### Concept

The **Join XML** task joins the content of its input XML files. In case you do not want the full content of all these input files, there are options to determine what parts you want or from what root level down that you want their content.

Some typical examples:

- The information you need is spread over several source XML files, maybe even coming from different systems. You need (parts of) them combined in 1 XML file.
- You want to change the content of an XML. After splitting it you can re-join specific parts.



**Note:** The **Map Data** task can also be used to *join* XML files, but it offers much more features and options than this **Join XML** task.

### Example and Options

The **Join XML task** joins multiple input XML files into 1 output XML file. The default option of this task is to take the full content of the input files and join everything together into 1 XML file.

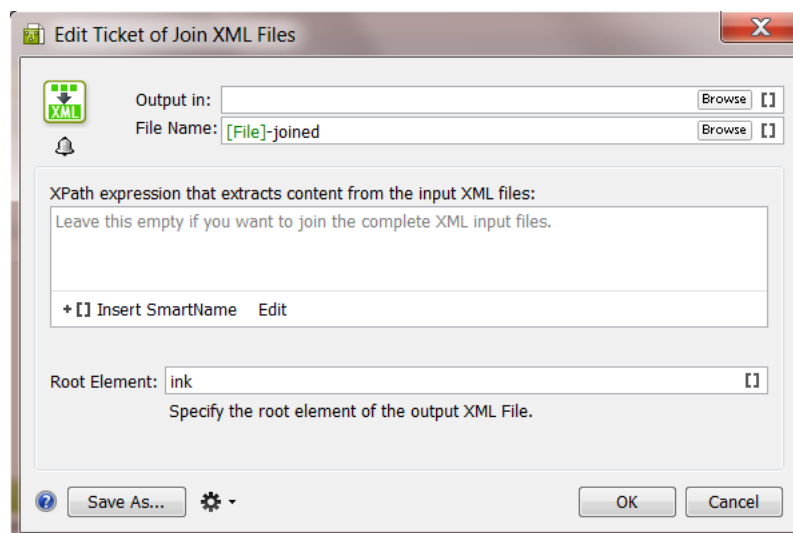

#### Name of the output XML file

The default name of the output XML file is set to **[File]-joined**. **[File]** is here the name of the first input file. You can of course change this setting.

#### Xpath expression that extracts content from the input XML files



**Tip:** In the previous topic about the **Split XML** task, we introduced **Xpath expressions** and also introduced the **XPath Builder** tool.

This canvas is where you can define the content of the output XML. If you do not want the full content of all your input files, use XPath expressions to define what you want to extract from them. Per input file, all nodes that comply with the given XPath expression are imported into the output XML file.

Click on  to insert **SmartNames** to help build your XPath expression.

Click on  to open the **XPath Builder**. For more info on **XPath Builder** please see [The XPath Builder](#) on page 678 (chapter 'SmartNames').

If this canvas is left empty, and if you didn't specify a **Root Element**, then all the nodes under the root node are considered (XPath == /\*/\*).

### Root Element in your output file

Each input XML file has its own **root element**. You can define here what you want as **root element** in the output XML file. See an example where this root element was set to 'ink':

```
<?xml version="1.0" encoding="UTF-8"?>
- <ink>
  <name>BananaYellow</name>
  <type>Designer</type>
  <book>FruitColors</book>
</ink>
```

If this field is left empty, then the tag name of the root of the first input file will be used.

### Example

You have these 2 XML files:

- One XML file lists ink attributes of a (first) ink of a PDF:

```
<?xml version="1.0" encoding="UTF-8"?>
- <job>
  <name>banana.pdf</name>
  - <ink>
    <name>803</name>
    <type>pantone</type>
    <book>pms1000c</book>
    <angle>7</angle>
    <ruling>92</ruling>
    <dotshape>round</dotshape>
  </ink>
</job>
```

- Another XML file contains information on the ink coverage of that file:

```
<?xml version="1.0" encoding="UTF-8"?>
- <job>
  <name>banana.pdf</name>
  <customer>FruitCo</customer>
  - <ink>
    - <inkcov>
      <pct>27.12</pct>
      <mm2>6512</mm2>
    </inkcov>
  </ink>
</job>
```

You now want to join these 2 files into 1 XML file with **all** the ink attributes together.

- This is the result if you use **no options**:

```
<?xml version="1.0" encoding="UTF-8"?>
- <job>
  <name>banana.pdf</name>
  - <ink>
    <name>803</name>
    <type>pantone</type>
    <book>pms1000c</book>
    <angle>7</angle>
    <ruling>92</ruling>
    <dotshape>round</dotshape>
  </ink>
  <name>banana.pdf</name>
  <customer>FruitCo</customer>
  - <ink>
    - <inkcov>
      <pct>27.12</pct>
      <mm2>6512</mm2>
    </inkcov>
  </ink>
</job>
```

- This is the result when you set the option **Root Element** to **PrintItem**:

```
<?xml version="1.0" encoding="UTF-8"?>
- <PrintItem>
  <name>banana.pdf</name>
  - <ink>
    <name>803</name>
    <type>pantone</type>
    <book>pms1000c</book>
    <angle>7</angle>
    <ruling>92</ruling>
    <dotshape>round</dotshape>
  </ink>
  <name>banana.pdf</name>
  <customer>FruitCo</customer>
  - <ink>
    - <inkcov>
      <pct>27.12</pct>
      <mm2>6512</mm2>
    </inkcov>
  </ink>
</PrintItem>
```

- This is the result when you **also** used the **Edit** button to add the **XPath Expression** **/Job/ink**

```
<?xml version="1.0" encoding="UTF-8"?>
- <PrintItem>
  - <ink>
    <name>803</name>
    <type>pantone</type>
    <book>pms1000c</book>
    <angle>7</angle>
    <ruling>92</ruling>
    <dotshape>round</dotshape>
  </ink>
  - <ink>
    - <inkcov>
      <pct>27.12</pct>
      <mm2>6512</mm2>
    </inkcov>
  </ink>
</PrintItem>
```

Because the Xpath extracted only the content of <ink>, the pdf file name and the customer name are not kept in this joined file.



**Note:** To further change the structure, order or content, you can use the **Map Data** task.

## 24.5.6. Task 'Split XML File'

### Concept

Sometimes you want to split XML files to make them more easy to use Automation Engine workflows. These XML files typically come from an external system. The **Split XML task** needs 1 XML file as input and will write 1 or more XML files as output. Some typical examples:

- Every morning your MIS system sends you a list with new Jobs and their details. To use that XML for the **Create Job task**, you need to split it into 1 XML per Job.
- Your MIS system sends an XML per customer order, but your workflows are set up per production item of an order. In this case, the **Split XML task** helps you to generate an XML file per production item. This makes it easier to automate your workflow. This example is elaborated below.



**Tip:** You can also use this task to split an XML that was created by Automation Engine itself. For example to make that XML more manageable for an external system.

### Supported input files

The input of this task is XML. Files with a different extension than **.xml** will not be recognised or processed.



**Note:** Exception: JDF files are also allowed as input. The resulting output will be XML files. These XML files will no longer be valid as JDF file.

### How do you decide what to split?

How you split the task's input file is defined by XPath expressions (built of static text and SmartNames). The task splits each matching element into separate XML files.

The built-in **XPath Builder** will help you to write those expressions. See further.

## Example and Options

### General Behavior

- **Encoding**
  - When the input XML file contains a header that specifies an encoding (for example `encoding="ISO-8859-3"`), the task will write the output files in that encoding.
  - When no header or encoding is specified, the resulting files will have **UTF-8** encoding by default.

- **XML Validation**

The task will generate well formed XML, but there is no support for schema or DTD validation. References to DTD's for validation will be removed.

### Example

The following code is grouping 2 production items in 1 XML file:

```
<?xml version="1.0"?>
<job>
  <commoncomponent>Z</commoncomponent>
  <commoncomponent content="Y" />
  <productionitem>
    <subelement content="A" />
    <subelement>1</subelement>
  </productionitem>
  <productionitem>
    <subelement content="B" />
    <subelement>2</subelement>
  </productionitem>
</job>
```

To split each production item into a separate XML file, type this expression in the XPath input field:

```
/job/productionitem
```

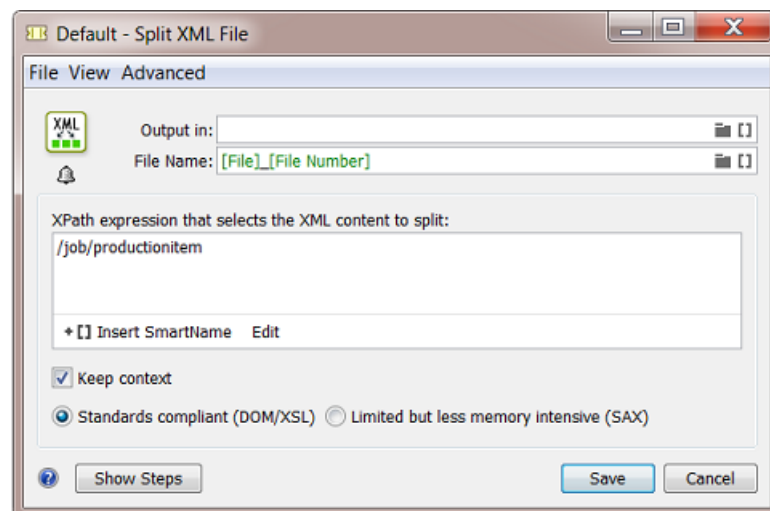

This will split the file into these 2 files:

```
<?xml version="1.0" encoding="UTF-8" standalone="no" ?>
<job>
  <commoncomponent>Z</commoncomponent>
  <commoncomponent content="Y" />
  <productionitem>
    <subelement content="A" />
    <subelement>1</subelement>
  </productionitem>
</job>
```

```
<?xml version="1.0" encoding="UTF-8" standalone="no" ?>
<job>
  <commoncomponent>Z</commoncomponent>
  <commoncomponent content="Y" />
  <productionitem>
    <subelement content="B" />
    <subelement>2</subelement>
  </productionitem>
</job>
```



**Note:** The SmartName [ **File Number** ] is available for this task only. It is added by default to automatically generate unique names for the output files.

### Options

- **Keep context :**

- When **selected**, the XML content that is not selected by the expression will be kept in the output file, of course except the sibling elements of the selected elements (siblings are elements at the same level with the same name).

By also keeping this extra context info, the result XMLs will look like the input XML, as they will still have the same structure.



**Attention:** With this option selected, the next option (the below described setting to decide which parser method is used (DOM or SAX)) can influence which extra contextual parts are kept in the output XML files.

- When **not selected**, the output file will only contain the parts that your XPath expression selected.

Using the above example as input, the task will split it into these 2 XML files:

```
<?xml version="1.0" encoding="UTF-8" standalone="no" ?>
<productionitem>
  <subelement content="A" />
  <subelement>1</subelement>
</productionitem>
```

```
<?xml version="1.0" encoding="UTF-8" standalone="no" ?>
<productionitem>
  <subelement content="B" />
  <subelement>2</subelement>
</productionitem>
```

- When an input file contains a **'namespace declaration'** in the parent XML structure ('xmlns'), then that namespace declaration will be added as an attribute of the top level element. For example:

```
<?xml version="1.0" encoding="UTF-8"?>
<job xmlns:esko="http://www.esko.com/myowns/">
  <commoncomponent>Z</commoncomponent>
  <commoncomponent content="Y" />
  <esko:productionitem>
    <esko:subelement content="A" />
    <esko:subelement>1</esko:subelement>
  </esko:productionitem>
  <esko:productionitem>
    <esko:subelement content="B" />
    <esko:subelement>2</esko:subelement>
  </esko:productionitem>
</job>
```

With such namespace declaration on the top level element, the split will result in these files:

```
<?xml version="1.0" encoding="UTF-8" standalone="no"?>
<esko:productionitem xmlns:esko="http://www.esko.com/myowns/">
  <esko:subelement content="A" />
  <esko:subelement>1</esko:subelement>
</esko:productionitem>
```

```
<?xml version="1.0" encoding="UTF-8" standalone="no"?>
```



```
<esko:productionitem xmlns:esko="http://www.esko.com/myowns/">
  <esko:subelement content="B" />
  <esko:subelement>2</esko:subelement>
</esko:productionitem>
```

- **Standards Compliant (DOM/XSL) or Limited but less memory intensive (SAX):**

The XML file format was not designed to contain huge dumps of information. However, some users want to use such huge XML files as input files for this task. This can cause memory problems. This is why the task also offers a different method in reading the file, one that is optimized to read (parse) huge XML files.

- **Standards compliant (DOM/XSL):**

This method takes the complete file in memory and then starts processing it. Depending on your server, this can become a problem when the size of the XML file is hundreds of megabytes. When, for example, the input XML file is 1 Gb, the AE server will, for this task, need at least 1 Gb of memory during the (long) time it processes this file.

'DOM' stands for Document Object Model. This is the XPath parser that is fully compliant with all standards.

Before AE v20, this task always used this DOM method for its XPath processing.

- **Limited but less memory intensive (SAX):**

This method only takes one element at the time in memory. This is advised for huge files that still have a simple structure.

'SAX' stands for Simple API for XML parsing.

The Esko implementation of the SAX parser does have these limitations:

- In combination with the option "Keep context", the context is limited to nodes that are higher in the xml hierarchy.
- Expressions can only have conditions that apply to a node itself, not to other nodes.
- Advanced features like the "/" operator, functions and axis are not supported.

In other words, only constructions like these are supported:

- /nodename/nodename
- /nodename[@attribute='value']/nodename[@attribute='value']
- /\*[local-name()='nodename'][(namespace-uri()='http://...']

Learn more and see several examples in [The DOM or SAX choice affects the result of 'Keep Context'](#) on page 1836 .

## Creating XPath Expressions

Usually you will not define the XPath expression by typing it in the task window yourself. Use the **Edit** button to open the **XPath Builder**. This tool will help you create your own correct XPath expression by clicking the variable elements. By selecting parts in the window with **Example XML Content**, you will see the resulting XPath expression automatically appear in the top part of this tool.



**Important:** When the **Example XML content** window is empty, this means that you forgot to select an XML input file before opening the **Split XML task**.

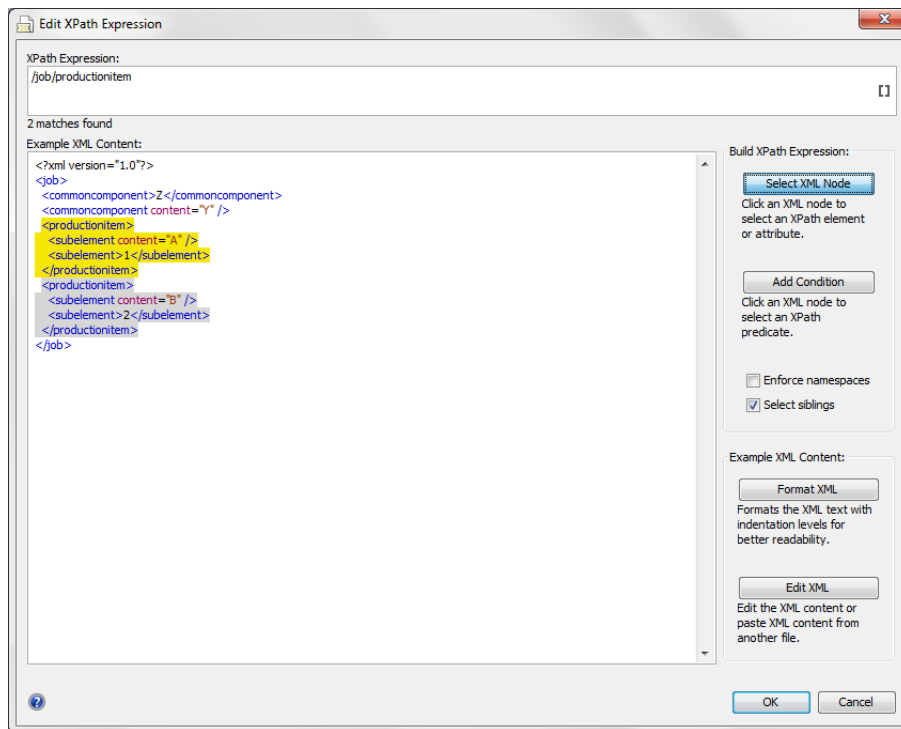

Selecting the option **Select siblings** allows you to automatically select the right level.

In above example, the user selected the level 'productionitem'. The selection is shown in yellow. The siblings are also automatically selected and are shown in grey. The correct **XPath expression** that is needed to split that level of elements will automatically appear in the top part of this tool.

You can easily build complex expressions with this tool, such as:

- selecting elements conditionally.
- selecting an element from a specific 'namespace'.

Find more information on the **XPath Builder** in [The XPath Builder](#) on page 678 (chapter SmartNames).

### The DOM or SAX choice affects the result of 'Keep Context'

The option to 'Keep context' can lead to different output in 'SAX' versus in 'DOM'. See various examples below.

What if you do not want that result? Your only alternative is to use the other parsing method (DOM / SAX). Both methods have their own specific effects in how they 'Keep context'.

The logic behind these effects is too complex to be described by rules. We can only illustrate them via below examples.



**Note:** When showing XML files like the below examples, we always use the application Notepad ++. When you open XML files in a browser, you might detect slight differences in how they interpret their grammar. For example An open/close on 1 same line in stead of spread over 2 lines.

#### Example 1 - Without 'Keep context'

Below example shows how the input file, with that XPath expression, is split into 3 output files, one for each selected node.

The content of the output files is decided by the XPath expression combined with the other 2 options. In this simple example, without 'Keep context', the result is the same whether 'DOM' or 'SAX' is chosen:

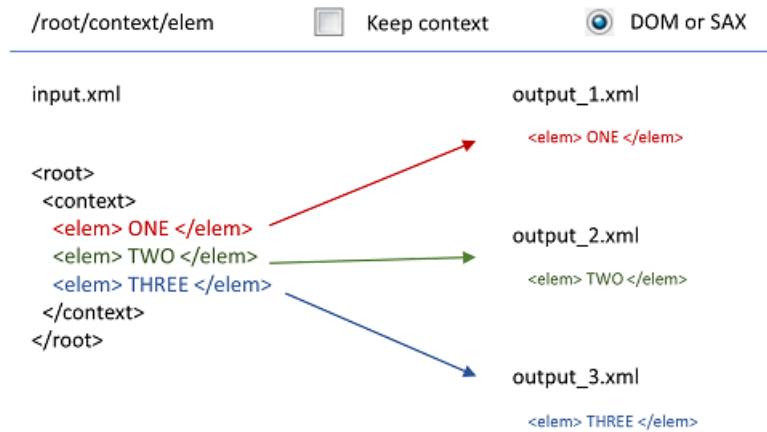

### Example 2 - With 'Keep context'

This is the same example as above but now the option 'Keep context' is selected.

The output now also contains other XML content.

With this simple input file and with this xpath expression, the result is the same whether DOM or SAX is chosen:

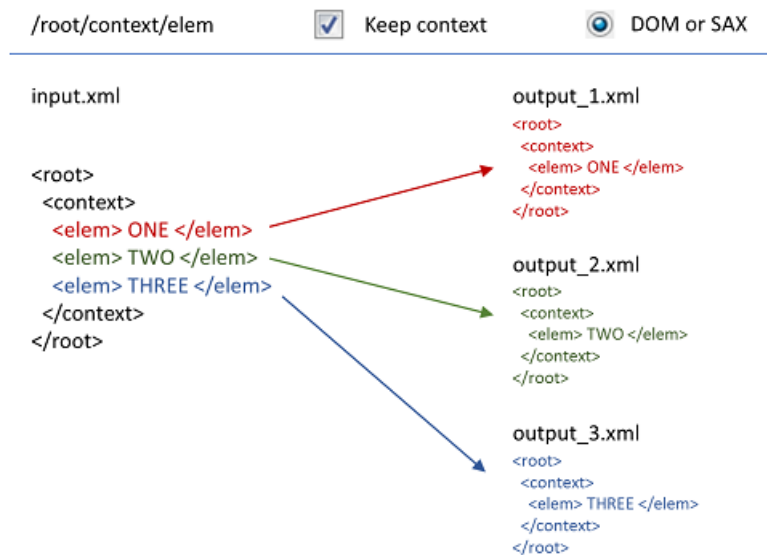

### Example 3 - With 'Keep context', SAX

This time the input file and also the XPath expression are slightly different.

This is the output when we use the 'SAX' method:

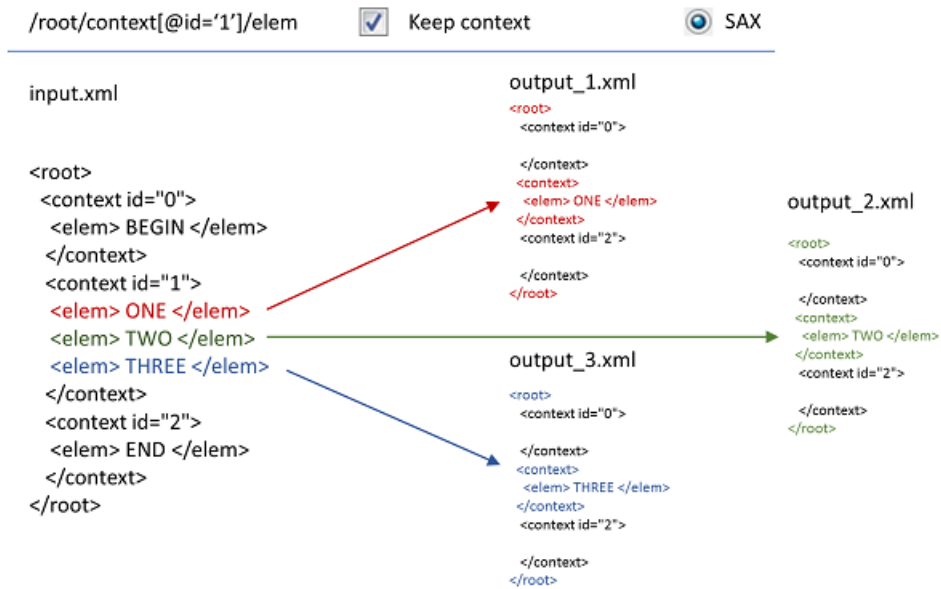

### Example 4 - With 'Keep context', DOM

This is the same as the example above but this time we used the 'DOM' method. Notice the difference in the output:

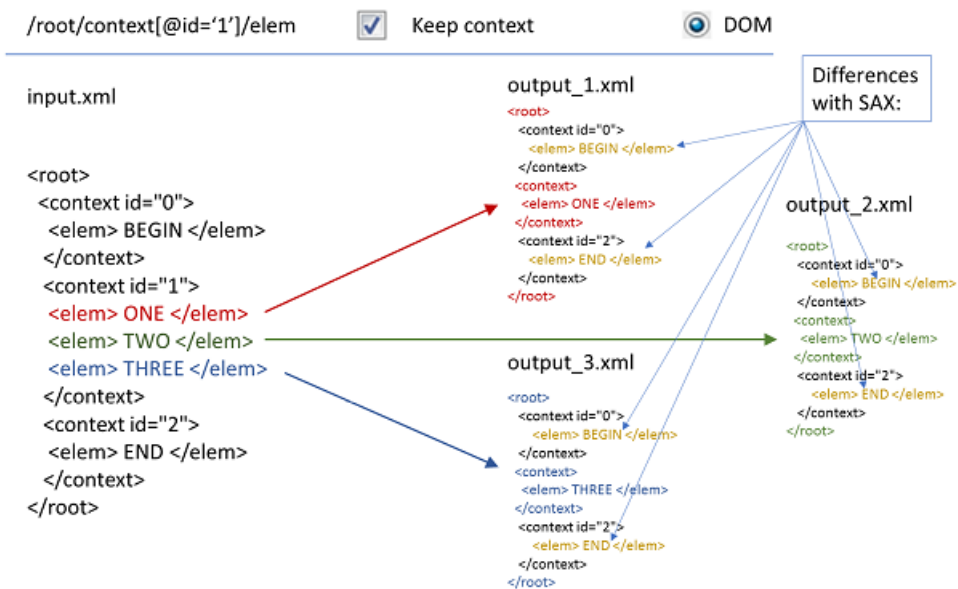

### Example 5 - With 'Keep context', SAX

This is the same as example 3 but a level deeper: See the extra /sub/ in the XPath expression. This time, also the level of the 'sub' element is kept in the output. But again it stays empty:

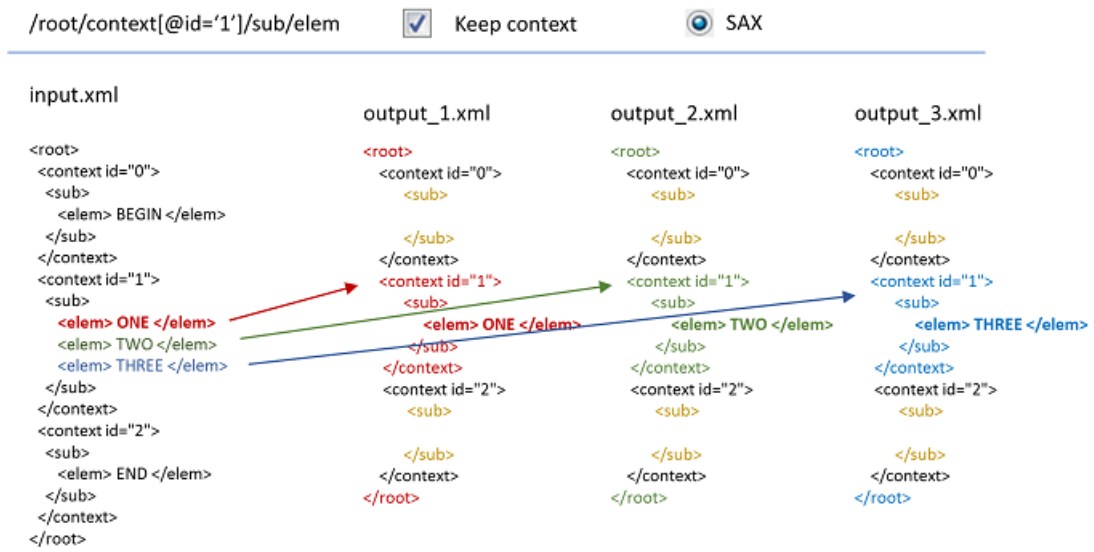

**Example 6 - Another example where SAX keeps less XML context than DOM**

This time the XPath expression extracts a 'type':

- Using **SAX** parsing:

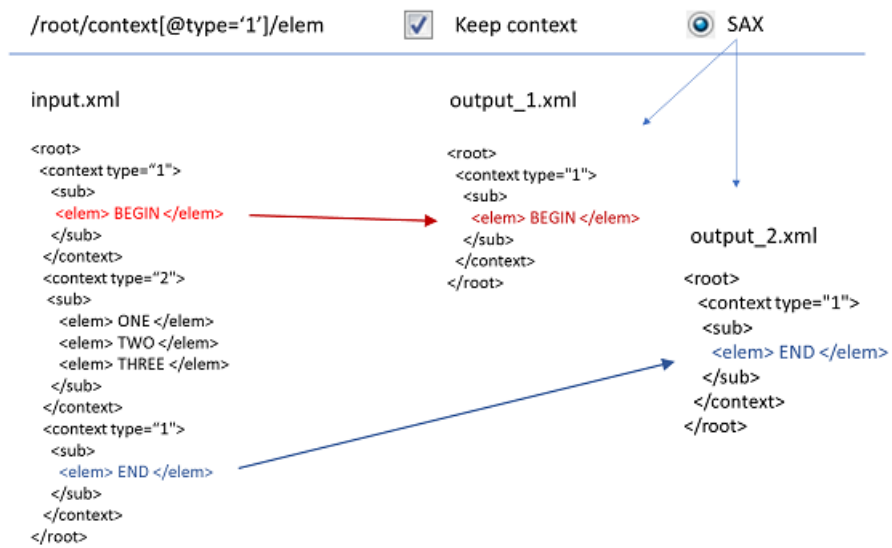

- Using **DOM** parsing.

Again, the 'DOM' method keeps more context information:

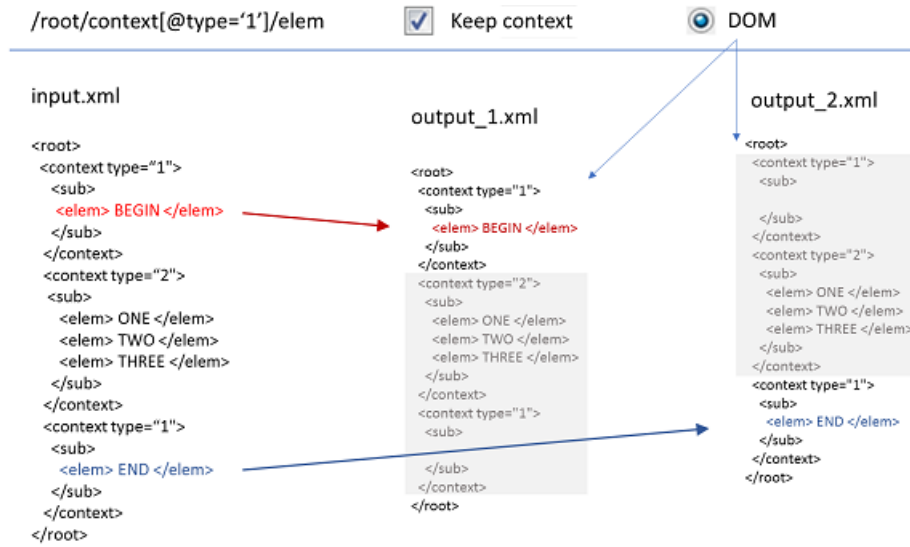

**Examples of unsupported Xpath expressions when using 'SAX'**

Whether you use 'Keep context ' or not, various types of XPath expressions are not supported when using the 'SAX' method:

- When using 'SAX' , the operator '/' is not supported.

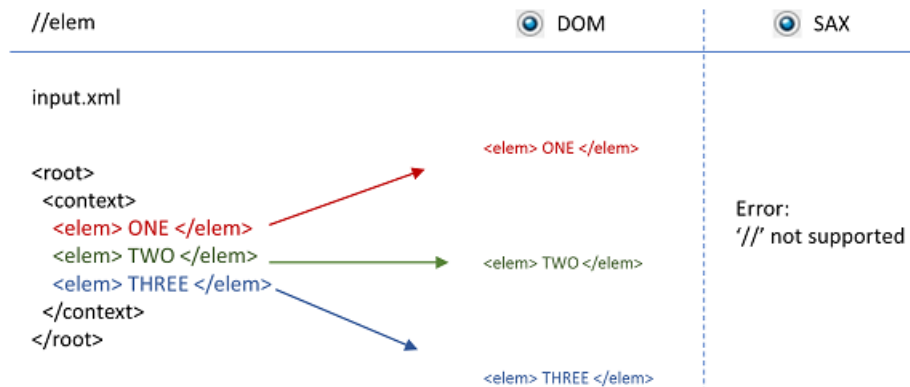

- When using 'SAX', recursive expressions are not supported (expressions on sub-element).

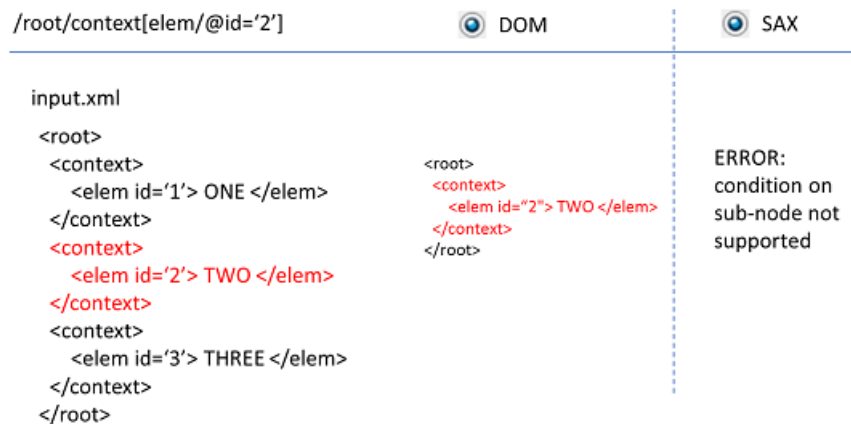

- When using 'SAX', also these expressions will result in an error:

Not supported when using 'SAX'

/root//elem	'//' inside an expression, not just at the start
/root/context/company[substring(@name,0,4)='Esko']	Functions on attributes
/root/context/elem[../@id='1']	Referring to parent nodes
/root/context/sub/elem[text()='ONE']	Selecting on the text of an element
/root/context/sub/elem[string-length(text())=3]	Selecting on the length of a text of an element
/root/context/sub/elem[position()=last()]	Selecting on the position of an element
/root/context[following-sibling::context/@id='1']/sub	Selecting a next element

## 24.6. Tasks Interacting with other Systems



**Note:** Apart from the tasks that we here document, Automation Engine can also offer these tasks that are only available through Esko Solution Services:

- [Task 'Interact with SAP'](#) on page 1846
- **Run ArtiosCAD Standard**
- [Synchronize ArtiosCAD Boards](#) on page 510
- [Synchronize ArtiosCAD Companies](#) on page 511
- [Export ArtiosCAD Design Info](#) on page 312

### 24.6.1. Task 'Interact using JDF'



**Attention:** This task is only available via [Esko Solution Services](#).

This task submits a JDF file to a JDF enabled device or system using a `JMF SubmitQueueEntry` command.

The task takes a JDF file as input.

After sending the `JMF SubmitQueueEntry` command, the task remains in a waiting state until the JMF controller sends back a `JMF ReturnQueueEntry` command to Automation Engine. The output of the task is the returned JDF file.

#### Task Settings

- **JMF Controller:** This is the HTTP address of the JMF controller.
- **Submit MIME (JMF+JDF):** If this option is enabled, a MIME package containing the `JMF SubmitQueueEntry` and the input is made and submitted to the JMF controller over HTTP. If this option is not enabled, the JDF is submitted to the JMF controller.
- **Include auxiliary files (PDF...) in MIME package:** If this option is enabled all external files referred to in the JDF with a "file:" URL will be included in the MIME package.

#### In a SaaS setup

To enable an AE SaaS server to communicate to a local device that supports HTTP JDF/JMF, it would require that that device exposes its HTTP port, which is something your local IT could refuse this for security reasons.

To solve this, the AE SaaS server can use this task to communicate with that local device via the local Agent. The task ticket has an extra option:

- **Agent:** Select the local Agent. Learn about the Agent [here](#).



Examples of such local devices with an HTTP JDF/JMF interface are an AVT inspection system, a Xeikon digital press, etc.

This communication can be set up via your Esko SaaS support staff.

### 24.6.2. Task 'Interact using JMF'



**Attention:** This task is only available via [Esko Solution Services](#).

This task will submit a JMF to a JDF enabled device or system.

The task takes a JMF as input. The output of the task is the JMF response of the JMF controller to this message.

Options:

- **JMF Controller:** This is the HTTP address of the JMF controller.

#### In a SaaS setup

To enable an AE SaaS server to communicate to a local device that supports HTTP JDF/JMF, it would require that that device exposes its HTTP port, which is something your local IT could refuse this for security reasons.

To solve this, the AE SaaS server can use this task to communicate with that local device via the local Agent. The task ticket has an extra option:

- **Agent:** Select the local Agent. Learn about the Agent [here](#).

Examples of such local devices with an HTTP JDF/JMF interface are an AVT inspection system, a Xeikon digital press, etc.

This communication can be set up via your Esko SaaS support staff.

### 24.6.3. Task 'Interact with Database'

#### Concept



**Tip:** The tasks that interact directly with external systems were introduced in [AE tasks Interacting directly with the External System](#) on page 1773. You there also read how this task compares to the **Database Access Point**.

The **Interact with Database** task allows you to communicate directly with an external database (one that is not part of AE). It allows both getting information from that database (read) and sending information to that external database (write).



**Warning:** This task may not be used to interact with Automation Engine databases. This is not supported by Esko. This can damage your server configuration.

As mentioned in the chapter [Integration Concepts](#) on page 1771, a typical use for this task is to feed information back to external systems by using this task in a workflow. For example, you can set up this

task to update a record in a table of your MIS when your workflow has reached a certain stage. For example setting the status record to 'Proof Ready'.



**Warning:** See the important remark in the task panel. As mentioned earlier in this document, using SQL statements to change records of an external database can potentially harm that database. If you are using this technique then this means that you have a database specialist who takes all liabilities for these SQL queries.



**Note:** In an [AE SaaS](#) setup,

- This task is using a local Agent to interact with the local external database. The task resolves and splits the SQL statements and then submits the SQL statements to the Agent. The task waits until the SQL statements are executed by the Agent.

When the Agent has executed the SQL statements, it uploads the resulting XML files to the AE SAAS output location(s) and then stops the task(s).

- Connecting to a local database via ODBC is not supported.



**Tip:** The page [Examples](#) on page 1858 contains 2 examples that interact with an external database.

## Setup and Options

### File Name

When the SQL query is a 'select' statement (see further), the task will dump the found records in an XML file. The default ticket offers the SmartName **[Table Name]** as name for that output XML file. In below screenshot, this name would then be 'ProductionDetails'.



**Note:** The SmartName **[Table Name]** is only offered in a context where it makes sense.



**Attention:** Not all SQL queries will resolve a name of a database table. Do not use the SmartName **[Table Name]** when it is possible that no table name is found.

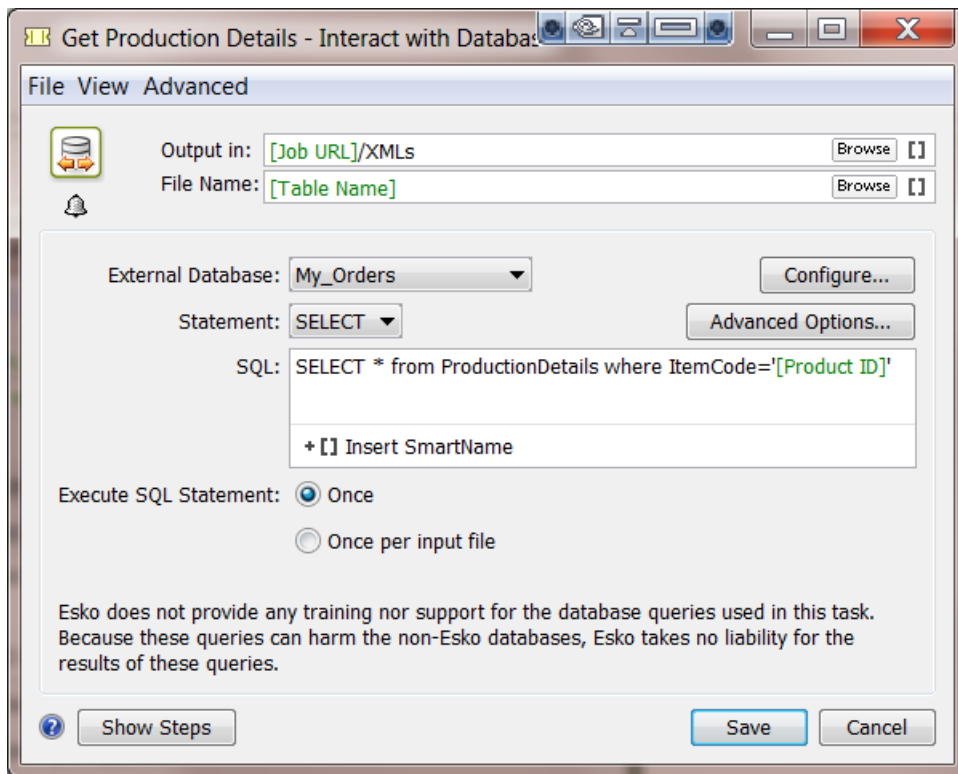

**External Database**

Select a database from the list of configured databases. Click **Configure...** to access the configure tool directly. Learn more about configuring **External Databases** in the [the related item in the Configure tool](#).



**Important:** Before linking Automation Engine with an external database, please check your license agreements with the database manufacturer.

**Statement**

Choose the type of SQL statement that you want to use: **SELECT** or **OTHER**.

- **SELECT**

When using the **Select** statement, the output of the task will be an XML file.

See an example of such a resulting XML. Notice that the SQL statement is also mentioned inside.

```
<?xml version="1.0" encoding="UTF-8" ?>
- <rows created="2013-05-23T10:41:32.100+02:00" producer="sqlexec" select="select * from ProductionDetails where Factory='FRANCE' startrec="1">
- <row>
  <c n="Factory">FRANCE</c>
  <c n="Machine">S802</c>
  <c n="ItemCode">FR-04742</c>
  <c n="Run">March13</c>
  <c n="QC">Passed</c>
  <c isNull="1" n="Comments" />
</row>
</rows>
```

**Advanced Options...:** You can avoid creating an XML file that is too big by limiting the number of records with the option **Maximum number of records per file**. The task will then generate as many files as needed.

- **Other**

In this mode, you can execute any other SQL statement such as INSERT, UPDATE etc. However, the task will in this case not generate an output file.



**Note:** When the **Statement** type is set to **Other**, you cannot execute a **Select** statement.

In this example the status of the Job is changed in the orders database:

External Database:

Statement:

SQL: UPDATE Orders set Status='Proofready'  
where OrderNR=[Order ID]

+ [ ] Insert SmartName

### Execute SQL Statement

Decide if you want the SQL statement to be executed **Once** or **Once per input file**.

For example: You have multiple input files for this task: banana.pdf, lemon.pdf and mango.pdf. When your SQL statement uses the SmartName [File](= the task's input file), then the option **Once per input file** will make the task run **for each input file**. With the option **Once**, the task would only run for the banana.pdf (the first input file).



**Tip:** Starting a task once and having it run on multiple input files is much lighter for the software than starting the task multiple times with each time only one input file.

### 24.6.4. Task 'Interact with SAP'

The **SAP** access point and the **Interact with SAP** task serve to integrate with an ERP system from [SAP](#). Such integrations are managed through assistance from [Esko Solution Services](#).

### 24.6.5. Task 'Interact with Web Service'

#### Concept



**Tip:** The tasks that interact directly with external systems were introduced in the chapter [Integration Concepts](#) on page 1771.

The **Interact with Web Service** task uses HTTP requests to communicate with a web service of an external system. Both **read** ('GET') and **write** ('POST') commands are possible. The result of this task is typically an XML file.

When an external system is running a web service, you will be able to access it via HTTP (HyperText Transfer Protocol). However, to do this, you also need to learn **what** you can communicate to that

system, what language you need to speak to it. Some applications will indeed publish their API (Application Programming Interface). And it is that API documentation that will tell you what you can enter in the **Interact with Web Service** ticket.



**Tip:** The section [Examples](#) on page 1858 in this chapter contains an example where a web service is contacted.

**Difference with a Web Service Access Point.**

- A [Web Service Access Point](#) is a way for an external system to speak to the web service of Automation Engine. This **Interact with Web Service** task is **the reverse**: it is Automation Engine that interacts with the web service of an external system.
- An **Access Point** is used to **start** a workflow. This **Interact with Web Service** task can be inserted at any step of the workflow.

**What with an AE SaaS setup?**

An AE SaaS server in a data center will not be able to access an external system that is not exposed to the internet, as will be the case for for example the MIS in your company's LAN.

To still enable this type of communication in an AE SaaS setup, AE will use the local Agent:

- The task (AE) will communicate to the Agent that was set up in the network of that external system.
- an AP ...

Learn more in the Config tool where you set up these links to [External Web Services](#) on page 199.

**Setup and Options**

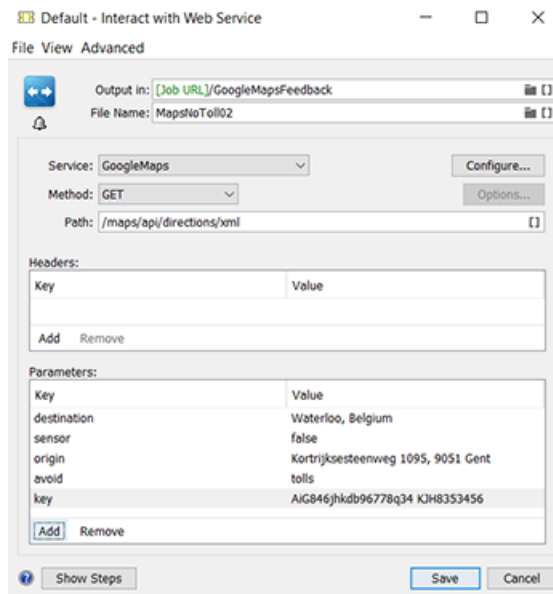

**Output folder and File Name**

Define here the path and name of your output file. The type of output file is defined by the API. We advise to choose XML.

When the **Method** is **GET**, this file will contain what the external system returns you. When the **Method** is any other type, the output file will only contain a status of the interaction (for example 'OK').

**Service**

Choose the web service from the list. Click **Configure...** to access the **Configure** tool where you define such external Web Services. Learn more in [this related item in the Configure tool](#).

**Method**

There are various types of HTTP methods that you can send to a web service. Choose the method from the list:

- **GET**. This most frequently used method will retrieve data from that external system. Consider the URL as the question and the output file as your answer.

For example: Ask Google Maps the distance from your company to your customer

- **POST**. This method creates a new object on the external system.
  - This method is commonly used to post actual data, to upload a file to the external system. Therefore, click on **Options...** and choose to **Attach input files**. All input files are added to a single HTTP request and SmartNames are resolved in the context of the first input file. In case each input file must be sent separately, then add a **Data Splitter** task before the **Interact with Web Service** task in the workflow. In that case SmartNames will be resolved for each file.



**Note:** The parameters are sent as "application/x-www-form-urlencoded" data. When XML files are attached, the data is sent as "multipart/form-data".

- The POST method also enables to send a SOAP request. The exact text of the SOAP request needs to be put in an XML file and you need to add a single parameter "SOAPAction" with the needed value.



**Note:** the **Create XML** task can be used to embed SmartNames inside the SOAP request.



**Note:** Find an example in the [Esko Knowledge Base](#).

- **Options...**
  - **Attach input files:** Select this if you want to include the task input files into the POST.
  - **Use chunked encoding:** Select this to use "HTTP Chunked Encoding", which means there is no size limitation. This is advised when posting large files.



**Note:** Note that this can only work if the receiving server supports this HTTP protocol extension.



**Note:** When selected, it is also used for data that might *return* as a result of your POST command.

- **PUT**. This method requests the external system to store data or information under the given (existing) URL.
- **DELETE**. This method requests the external system to delete the information corresponding to the given URL.

- **Select SmartName....** You can even use a SmartName to define the method.



**Note:** **PUT** and **DELETE** are only used for 'RESTful' web services. 'REST' is the main architecture style of HTTP. An alternative is 'SOAP'.

### Path

This path will be documented in the API of the external system. APIs often present several paths that you can address.

In the above example of a ticket to access Google Maps, the information will be gotten from the 'directions' part of the API. The path ends with XML which here means that we choose to get an XML file back (and not a JSON file for example).

### Headers

The API documentation will instruct you if you need to use HTTP headers. To do this, add their key and value in the **Headers** list.

### Parameters

The API documentation will instruct you what parameters you can use. To do this, add their key and value in the **Parameters** list. This is where the actual 'question' will become more clear.

In the above example, you can see how the ticket asks Google Maps a distance between the origin and destination address. Other parameters could be more optional, like in this case the option to only calculate distances for routes that avoid toll roads.



**Tip:** Just Google "Google maps API" or click [here](#) to learn how Google Maps is a nice example of how an external system publishes its API.



**Note:** This does require you to first request a key via your Google Account.



**Tip:** [This page with examples](#) contains an example that uses the Google Maps API.

### Advanced

When this task type is used as a step in a workflow, the ticket shows an extra button '**Advanced**' at the bottom of the dialog.

- **Notification Rules....** Learn more in [Notification](#) on page 226.
- **Manage Public Parameters....** Learn more in [Using Public Parameters in Workflows](#) on page 838.
- **Map Output Parameters....:** Use this tool to map the output parameters of this task to [workflow parameters](#).

This for example makes it easier to [route](#) your workflow depending on the responses this task received from the web service (Choose to route based on SmartName Value and there select the workflow parameters).

These 2 output parameters can be mapped:

- HTTP Response Code
- HTTP Response Message

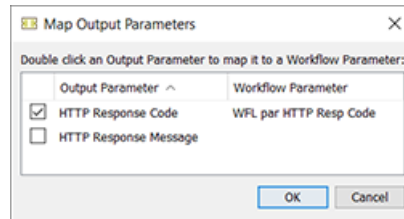

**Tip:** Learn all about HTTP response codes [here](#). Example: When a response code starts with '20', the interaction was a success. When it starts with '40', then it was not and you can route the workflow to a different next step.

## 24.7. Tasks often used in Integration Workflows

### 24.7.1. Task 'Create Job'

#### Concept, Workflow and FAQs

The **Create Job** task creates an Automation Engine **Job** based on an XML input file containing the job parameters. Typically this input XML file comes from your business system. It is inside this system that the job-orders are decided and where many of its preprocess production parameters are entered first. Typically, a **Folder Access Point** receives this XML file and then starts a workflow containing this **Create Job** task.



**Tip:** Read more about the concept of integrating with external systems in [Introduction](#) on page 1769.



**Tip:** The chapter [Examples](#) on page 1858 contains many examples where this task is used.

It is possible that the XML file that feeds this **Create Job** task does not come directly from the business system. Maybe you first have to combine it with another input file that contains other job parameters. Such other parameters could for example arrive as metadata inside a PDF. The data formatting tasks **Split XML**, **Join XML** and **Map Data** offer all tools to combine these parameters into 1 XML file.

#### Should the XML be in a specific format?

No, but it should be a valid XML of course. You will set up **SmartNames** or **XPath expressions** that map the vocabulary of that business system to the terminology required in Automation Engine. For example your business system uses the term 'Order Number' to describe the name of a job. You can then make a SmartName that maps 'Order Number' to 'Job Name'.

#### Can one XML file create multiple Jobs?

If your XML contains the description of multiple jobs, then you first need to split that XML into multiple XML files that each describe one job. To do that you will set up a workflow with the **Split XML** task in



front of this **Create Job** task. Also use the **Data Splitter** task to make sure that the **Create Job** task is started for each incoming XML file.



**Can the input file be a CSV file?**

If you want to create a Job from a CSV file, then use the **Map Data** task to convert it to an XML file.

**What if my business system can not export an XML file?**

When your business system is not capable to export a job description in XML format, you can consider the alternative where Automation Engine asks your business system if there is a new job to be created. Learn about the various possible techniques in [Access Points](#) on page 1777.

**Can the task find its parameters outside the task's input file?**

Yes. The input file of this task does not have to be the XML file that delivers all the parameters. It can even be a PDF. The parameters could also be looked for in other files than the task's input file. Some examples of such special setups:

- A **Create Job** ticket with a PDF as input file and where the SmartNames do SQL queries to an external database.
- A **Create Job** ticket with SmartNames that find their values in **workflow parameters**.
- A **Create Job** ticket with (SmartNames that are) Xpath expressions to some centrally stored XML that the business system writes there every night at 3 AM.

The **Create Job** task can get the values for its parameters from different sources. It can for example

- find the main job order specifications from the business system's XML file (name, ID, customer, due date)
- AND get the some ink information from the metadata of a PDF
- AND get a custom parameter 'Press' from a workflow parameter `[wfp.PressName]`.

**What if the Job already exists? Can I use this task to update Jobs?**

Yes you can also use this task to update existing Jobs. If Automation Engine detects that the Job already exists, it will update the Job with any new or changed values.

This task will function as an *Update Job* task

- when it sees that the [Job Name] already exists
- OR when it sees that the *combination* of [Job Order ID] and [Job Sub Order ID] already exists.

At the end of this chapter, you can find a sample XML that can be used to create jobs from. Remember that the format of the XML is free. This sample is not a template, it is just one example.

We will now document the settings in the different tab sheets.



**Important:** To set up a **Create Job** ticket, you need advanced knowledge of SmartNames.

**Job**

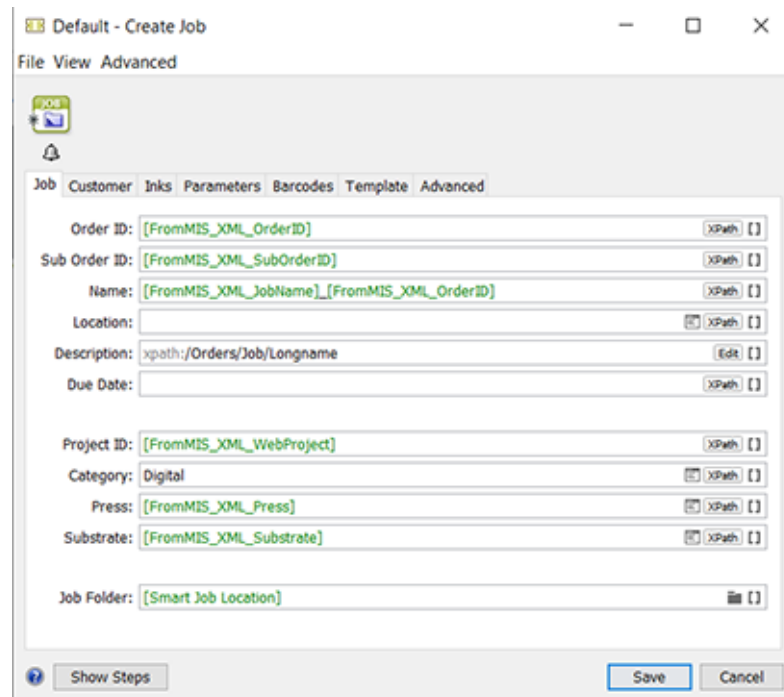

For most of the fields in this task, you can choose to set a SmartName or a combination of SmartNames.

You can also use an XPath expression to extract values from an XML file. Click  to use the [XPath Builder](#) or if you are an expert in XPath, type them in yourself.



**Attention:** In the input fields that offer an , it is not supported to insert a SmartName in your XPath expression! Still, the SmartName icon stays visible which might be confusing.

In these fields, XPath expressions are **direct** 'inline' commands to the input file, which needs to be an XML file. In other cases, for example when the input file is a PDF file, you could use [SmartNames, which can also be built out of XPath Queries](#). SmartNames are then a **indirect** way of getting the value (not 'inline').

- **Order ID:** This field must have a value. You can not leave it empty.
- **Sub Order ID**
- **Name:** In the screen shot example, we combined 2 SmartNames with some absolute text ( \_ ).
- **Location:** A Job's location is an attribute used for data filtering in My Workspace. Learn more in [Locations](#) on page 220. When you type in this field or use a SmartName, make sure the value matches exactly to the name of an existing location (case-sensitive!). When this is not the case, the task will create a new location.
- **Description:**



**Note:** The above example shows an XPath expression. If you are an expert in building XPath expressions, you can also directly type XPath expressions in this field. The syntax for doing this is "XPath:" followed by a valid XPath expression for the input file. Example:

```
xpath:/Orders/Job/Longname
```

- **Due Date:** The format needs to be compliant with ISO 8601 (YYYY-MM-DDThh:mm:ssTZD) . For example: 2014-07-28T12:00:00+01:00

- **Project ID:**



**Tip:** Some users use this field to define the name of the project on Esko WebCenter that corresponds with this Job..

- **Category:** For this field, you can also choose a category from the list.



**Tip:** The categories in the list are all those that were already used in a Job.



- **Custom Fields:** The custom fields that appear here are the ones that you defined in **Configure > Jobs > Job Setup** (maximum 6). Alternatively to using a SmartName or XPath, choose a value from the list.

- **Job Folder:** The system needs to know where to create the actual folder for this Job.



**Note:** Beware that you do need to define a *complete* network path here, not just a folder name.

You have these choices:

- Use the SmartName [**Smart Job Location**] to use this setting as defined in **Configure > Jobs > Smart Job Location**.
- Click  to browse to the desired job location.
- Click  to browse to a folder in a container, and then use SmartNames to define a subfolder.



**Note:** If you want to make the path smarter by adding the name of the customer, then you best set that up as a **Smart Job Location**.

## Customer

Using the same techniques as described for the tab 'Job', you here define the customer details for the Job you are creating.

- **Customer ID.** You can alternatively select the ID from the customer list panel.
- **Customer Name.**
- **Customer Description.**
- **Customer's Job Reference.** This is the name that your customer uses for this Job.
- **Customer Service Representative.** You can alternatively select the CSR from the list.
- **E-mail.**

## Inks

Setting up the inks for the new Job can only be done if the input file is an XML file and if the ink properties are stored in attributes of XML elements.

In the example below the XML input file contains an element "Farben" (German for "inks"). This is an array of "Farbe" elements, each describing an ink.

```

- <Farben>
<Farbe Farbbuch="Process" Farbtyp="Normal" Farbnamen="Cyan" Winkel="15" Lineatur="150" Punktform="CS4" Druckmethode="Offset" />
<Farbe Farbbuch="Process" Farbtyp="Normal" Farbnamen="Magenta" Winkel="75" Lineatur="150" Punktform="CS4" Druckmethode="Offset" />
<Farbe Farbbuch="Process" Farbtyp="Normal" Farbnamen="Yellow" Winkel="0" Lineatur="150" Punktform="CS4" Druckmethode="Offset" />
<Farbe Farbbuch="Process" Farbtyp="Normal" Farbnamen="Black" Winkel="45" Lineatur="150" Punktform="CS4" Druckmethode="Offset" />
<Farbe Farbbuch="PANTONE+ Solid Coated" Farbtyp="Normal" Farbnamen="PANTONE Warm Red C" Winkel="45" Lineatur="150" Punktform="R" Dr
<Farbe Farbbuch="ClassicColors" Farbtyp="Opaque" Farbnamen="White" Winkel="45" Lineatur="120" Punktform="R" Druckmethode="Offset" /
<Farbe Farbbuch="PANTONE+ Pastels & Neons Coated" Farbtyp="Transparent" Farbnamen="PANTONE 9284 C" Winkel="45" Lineatur="150" Punkt
<Farbe Farbbuch="Designer" Farbtyp="Technical" Farbnamen="Die" />
</Farben>

```

The **Create Job** task will create an ink in the new Job for each of these elements in the XML. The table in the dialog defines how to map XML attributes of each element to an ink property.

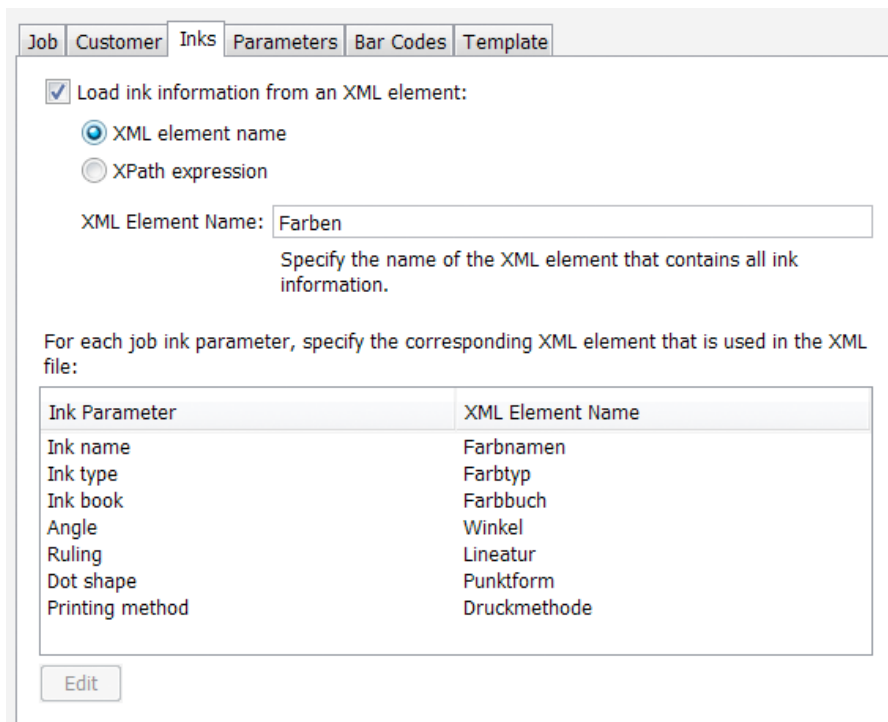

- **Load Ink Information from an XML element.** Enable this and then choose how you will load this specification: You have these 2 options:
- **XML element Name:** Indicate the XML element that contains the ink specification. In above example the ink info is described in the element `Farben`.
- **XPath expression :** Alternatively, use an XPath Expression to the XML element containing the ink information. For example: `/CreateJob/Farben`



**Note:**

- To open the **XPath builder**, select **XPath expression** and click on the **Edit** button in the text field.
- The XML that the ticket sees as input file will be loaded in the **XPath builder**. Alternatively, you can right-click in the canvas and choose **Paste from File...** to select the example XML input file.
- When you edit the XPath expression again, that same XML (example) input file will be automatically used.

For each job ink parameter, specify the corresponding XML element that is used in the XML file. To do this, select the parameter and click **Edit**.

- **Ink name**
- **Ink type**
- **Ink book**
- **Angle**
- **Ruling**
- **Dot Shape**
- **Printing Method**

**Parameters**

To add custom parameters to the job you are creating, click **Add** and enter its **Name** and **Value**.

Both fields are SmartName enabled. Typically, the **Name** will be an absolute value and the **Value** is a SmartName that extracts the custom parameters from an XML file.

For example:

Name	Value
Trapping	[FromMIS_XML_TrappingYesNo]
Trap Distance	[FromMIS_XML_TrappingDistance]

**Barcodes**

The **Create Job** task also allows to add parameters for one or more barcodes.



**Important:** The **Create Job** task does not check the consistency of these barcode parameters. This means that the creator of the input file is responsible to create barcode parameters that are compliant.

You can **Add** or **Remove** parameters for multiple barcodes.

For each barcode, you can set the following parameters by adding a SmartName or an XPath expression. Some also offer to select a value from a list.



**Attention:** Some parameters will not be relevant for some barcode types.

- **Type.**
- **Sub Type.** A list will be offered if you selected a **Type** that offers **Sub Types**..
- **Code.** As mentioned above, the code is not checked for validation here.
- **Composite Code.** Only some types offer to add an extra composite code.
- **Output Resolution**
- **Bar Width Reduction**
- **Device Compensation**
- **Narrow Bar.** Only some types work with a specification of Narrow Bar and Ratio
- **Magnification**
- **Ratio.** Only some types work with a specification of Narrow Bar and Ratio

## Template

You can use an existing job as a template job for the new job that you here create. If you decide so, you can select which attributes and parameters that you want to get from that template job.



**Note:** For more information about using template jobs and their options, see the dedicated chapter [Jobs](#) on page 538.

Select **Use an existing job as a template** if you want to create your job based on another job.

In **Choose Job**, **Select** the job from the list or use a **SmartName** to have the job selected. An example of a SmartName could be `[customer name]_template`

Then choose what to **Include** from the template job into the new job:

- **Files**
- **Folders**
- **Hot Folders.** This item will only appear if your server still has hot folders from before v14.
- **Tickets.** These are the (blue) Job tickets.
- **Milestones.** Times will be set relative to the creation date of the new job.

- **Parameters.** Custom parameters.
- **Inks.**
- **Categories**



**Attention:** If there any parameters that you pick up **both** from the input file and from a template job, then those from the input file will be kept.

### Advanced

The **Create Job** task can automatically launch a workflow when the new job is created and even when the task updates the job.

To do this, select when you want have a workflow launched and select the workflow from the list. You can even choose both moments.



**Note:** If the **Create Job** task itself is part of a workflow, the workflow that is chosen in this task will start immediately, as a separate workflow. It will not wait for the workflow that contains the **Create Job** task to finish.

The advantage of this function is that the chosen workflow will be launched *in the context of that created/updated job*. This means that all the used SmartNames will get their value from *that* job.



**Attention:** In case you create a workflow that contains the **Create Job** task as a workflow step and then continues with other steps, then the tasks *following* that **Create Job** step will not run in the context of the new/updated job: they will run in the context where the (main) workflow initially started!

### Sample Input XML

Click [this link](#) to find a ZIP with the samples used in the page 'Examples on page 1858'.

Download the ZIP file and unzip it to a local folder or directly into an **Automation Engine Container**.

In the folder named "Create a Job using XML", find a sample XML that you can use to test setting up SmartNames or XPath expressions and so build and test an example of the **Create Job** task.

## 24.7.2. Task 'Add To Products'

The **Add To Products** task allows to create Automation Engine **Products**. The task can get their properties out of file names, paths, SmartNames or values out of XML data.

This task is often used after workflow steps first made a smart selection of input files.

This task is documented in the chapter [Products](#) on page 594. Find a direct link [here](#).

## 24.7.3. Task 'Link Product To Job'

The **Link Product To Job** task allows to link or multiple **Products** to a **Job**.

This task is documented in the chapter [Products](#) on page 594. Find a direct link [here](#).

## 24.8. Examples

---

These examples will help you build and understand the workflows of typical integration use cases.

At the beginning of each example, we also mention which tools and tasks are used. We also add a link where you can find the sample (XML) files used in that example.



**Note:** An example often requires you to understand the features explained in the previous examples.

### 24.8.1. Creating a Job using XML

#### Summary

We will create a **Job** based on the sample XML. Most of the work is creating the XPath Query SmartNames.

Tools used in this example:

- A sample XML describing 1 job order
- **SmartNames** including **Xpath Builder**
- The **Create Job** task

#### Step 1 - Analyze your Input XML file

Click [this link](#) to find a ZIP with the sample XML file used in this example.

Save the file in a logical place in an **Automation Engine Container**.

Open it (double-click) and have a look at its structure:



```

<?xml version="1.0" encoding="UTF-8" ?>
- <CreateJob>
  - <Job>
    <OrderID>002</OrderID>
    <SubOrderID>002123</SubOrderID>
    <Name>XMLsample_to_CreateJob</Name>
    <Description>A sample XML to test the Create Job Task.</Description>
    <DueDate>2015-06-01T09:00:00.00+01:00</DueDate>
    <ProjectID>Project123</ProjectID>
    <Category>Offset</Category>
    <CustomField1>CustomField1</CustomField1>
    <CustomField2>CustomField2</CustomField2>
    <JobFolder>file://AESERVER01/MainContainer/FruitCo/XMLsample_to_CreateJob</JobFolder>
  + <Barcode>
  </Job>
  <InkSpecifications>
  - <Ink>
    <ColorBook>Process</ColorBook>
    <ColorType>Normal</ColorType>
    <ColorName>Cyan</ColorName>
    <Angle>15</Angle>
    <Ruling>150</Ruling>
    <Dot>CS4</Dot>
    <PrintingProcess>Offset</PrintingProcess>
  </Ink>
  - <Ink>
    <ColorBook>Process</ColorBook>
    <ColorType>Normal</ColorType>
    <ColorName>Magenta</ColorName>
    <Angle>75</Angle>
  
```

See how a lot of job info is inside the parent element 'CreateJob' and how the ink information is inside a different parent element 'InkSpecifications'.



**Note:** In this sample, even the full path for the *JobFolder* is filled in. This is usually not the case. A business system usually leaves it up to you to decide where to store your prepress data. Some MIS do want to control this as well. Advantage of already knowing exactly where your prepress files are is that they can then also show some of them to their MIS users (final PDF, JPEG..). However, most MIS will not decide that path for you but will ask you to let them know where you decided to create that JobFolder. In that workflow, the MIS usually wants you to return them a XML containing that JobFolder path.

## Step 2 - Create your SmartNames

SmartNames will read specific pieces of that XML and so populate the various properties of the Job you will create. To read parts of that XML, we will use SmartNames of the type **XPath Query**.



**Note:** You can also create SmartNames directly from within the **Create Job** task. However, because they are Xpath queries that involve a sample input file, we advise to create them using the main SmartNames tool . It will be somewhat easier to do it there.

### 1. Go to the SmartNames tool and indicate your sample input XML file

Because you will probably make a dozen new XPath SmartNames, it will be easier when you only have to indicate your sample input file once. Do this in the **Resolve all using:** section.

Include SmartNames From:

A workflow:

A product part:

---

Resolve all using:

A task:

A file:

---

Results:



**Note:** You do not have to click on 'Show' at this moment.

## 2. Make a first XPath Query SmartName

1. In the SmartNames tool, in the top bar, click on to create a new SmartName.. Choose Type **XPath Query**.

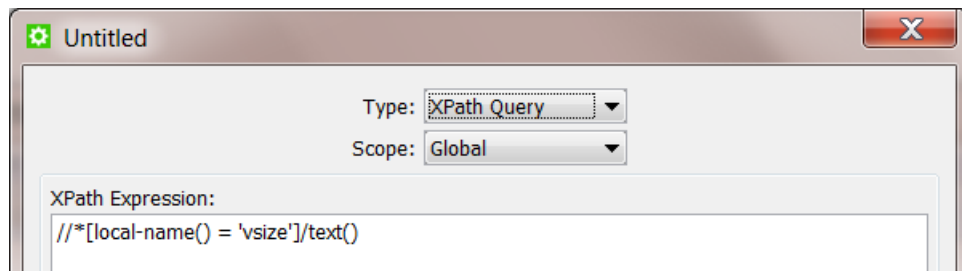

An example query about 'vsize' appears. It will be removed automatically later. See the part / text () at the end. This means that the query will not select the full element but only the value of that element.

At the bottom,

2. Click on 'Edit' to open the **XPath Builder**.

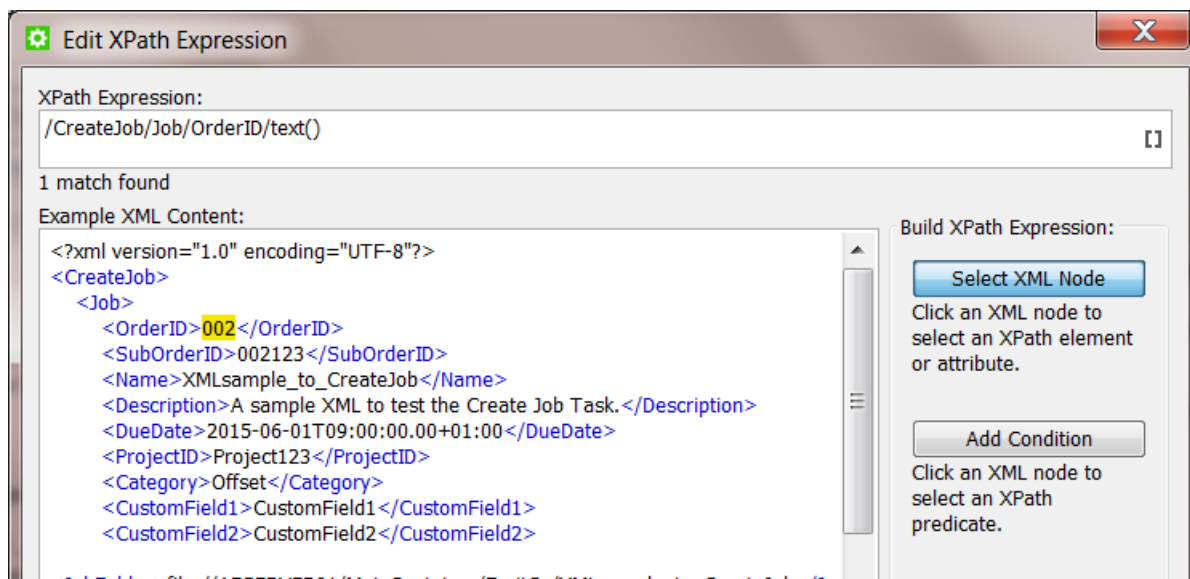

As a first SmartName, we will create the Xpath Query representing the Job's OrderID.

All you need to do here is click on the value that the SmartName will be looking for. It will be highlighted in yellow and the resulting XPath Expression will automatically appear in the top field.

3. Click on 'OK' to close the 'Edit Xpath Expression' dialog. The expression will have replaced the example one. The resulting value will also be shown bottom left in 'Result:' (in below screen shot: "002").
4. Now save your new SmartName. Give it a logical name and maybe add some tags and a description.

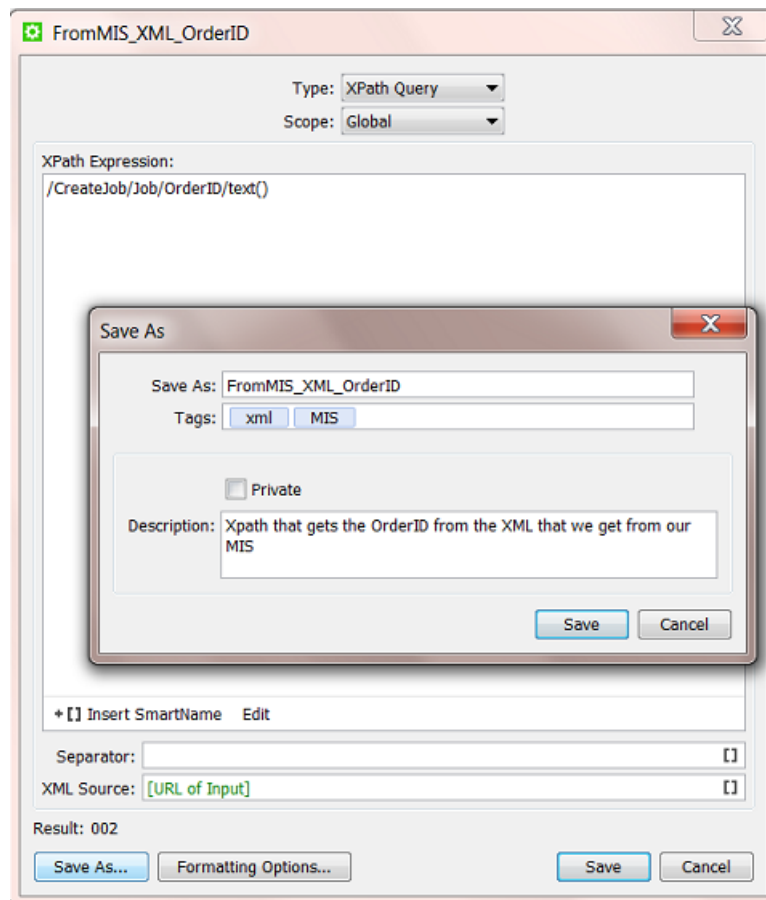

### 3. Now make the other SmartNames (quickly)

The next SmartNames will be made very similarly. Double click the one you just made and while keeping the SmartName dialog open, follow these steps:

- click **Edit**
- in the **Xpath Builder**,
  - click on the value you want the SmartName to represent
  - click **OK** to close the Xpath Builder
- click **Save As...** and enter an appropriate name, tag and descriptions

Repeat this for all the SmartNames you wish to use in the **Create Job** task.

### Step 3 - Insert the SmartNames in the Create Job ticket

Open a **Create Job** ticket and insert the created SmartNames in their corresponding fields.

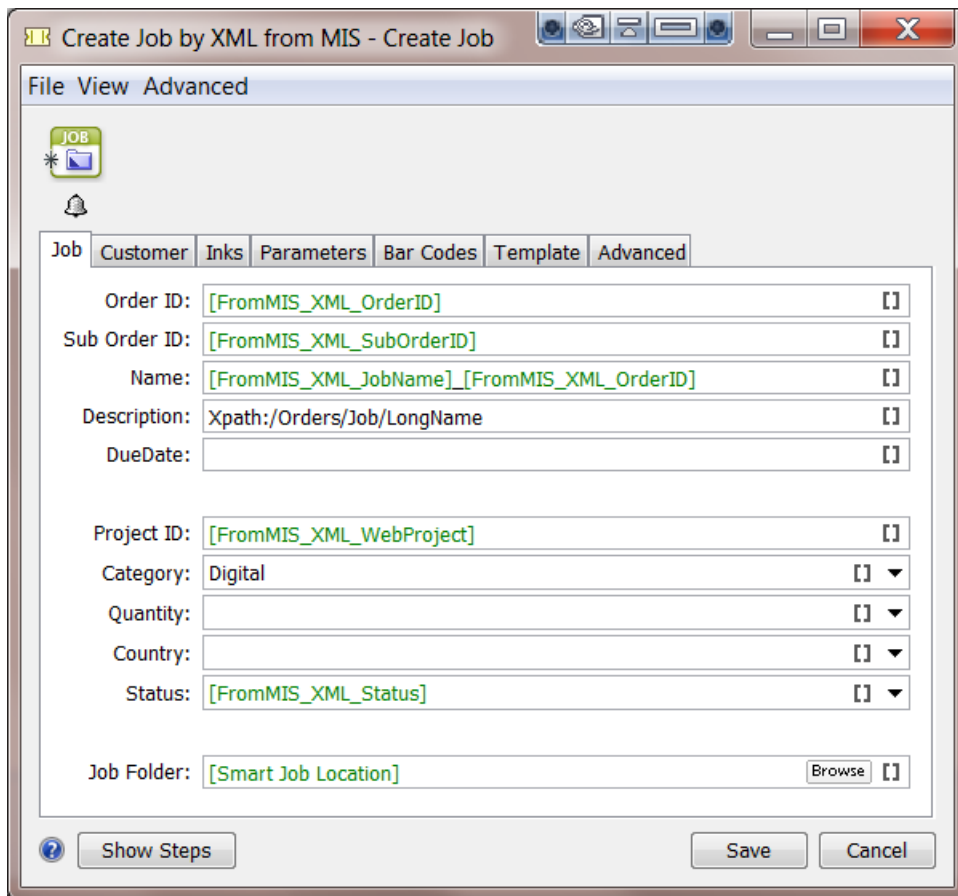

Do the same for all fields in the other tabs.

Don't forget to save your ticket.

### Picking up the Ink parameters from the XML

As explained in [inks](#) on page 1853, the **Inks** tab is constructed differently.

In our sample XML, see how the ink information is described in a parent element **InkSpecifications**. And in there, *per ink* in an element named '**Ink**'. And there are 8 inks described.

```

    <?xml version="1.0" encoding="UTF-8" ?>
- <CreateJob>
+ <Job>
- <InkSpecifications>
  - <Ink>
    <ColorBook>Process</ColorBook>
    <ColorType>Normal</ColorType>
    <ColorName>Cyan</ColorName>
    <Angle>15</Angle>
    <Ruling>150</Ruling>
    <Dot>CS4</Dot>
    <PrintingProcess>Offset</PrintingProcess>
  </Ink>
+ <Ink>
+ <Ink>
+ <Ink>
+ <Ink>
+ <Ink>
+ <Ink>
+ <Ink>
  </InkSpecifications>
+ <Customer>
+ <Parameters>
</CreateJob>

```

You also see that the names of the ink parameters are not all identical to those used in the Job setup in Automation Engine. In many cases these words in the XML may not be in English. This terminology in the XML (in the business system) needs to be mapped to the official one in Automation Engine. This is explained in [the documentation of the Create Job task](#).

See the correct settings for our example:

- The element name under which *all* the ink info is found is `InkSpecifications`.
- The parameter names in your XML (right) have been mapped to the standard names in Automation Engine (left):

Job Customer **Inks** Parameters Bar Codes Template Advanced

Load ink information from an XML element:

XML element name  
 XPath expression

XML Element Name:

Specify the name of the XML element that contains all ink information.

For each job ink parameter, specify the corresponding XML element that is used in the XML file:

Ink Parameter	XML Element Name
Ink name	ColorName
Ink type	ColorType
Ink book	ColorBook
Angle	Angle
Ruling	Ruling
Dot shape	Dot
Printing method	PrintingProcess



**Note:** These names are not case-sensitive.



**Note:** If one XML Element name is wrongly mapped, the Create Job task will not fail but only this wrong parameter will stay empty in the Job Inks setup.

- Alternatively, in our example, You can use this **Xpath Expression** to select that element describing all the inks:

Job Customer **Inks** Parameters Bar Codes Template Advanced

Load ink information from an XML element:

XML element name  
 XPath expression

XPath Expression:

Specify the XPath expression to the XML element that contains all ink information.

This is the result in the created Job:

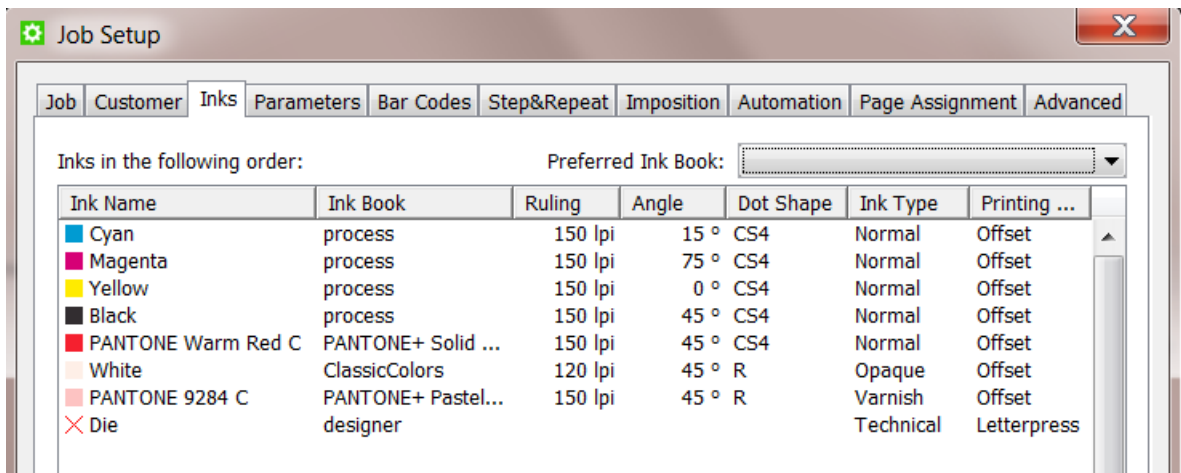

### Step 4 - Test your Workflow

Test your workflow by launching it from within the Pilot.

In the Pilot, select the input XML file and launch the workflow. It should create the Job and the Job should contain all the parameters you had set up.

When the Job was created but one or more parameters were not found, the status of that 'Create Job' workflow step will be 'warning' (orange).

- The task's details info will already tell you that "There were problems resolving some job fields".
- The task's log file will tell you what specific SmartName(s) has a problem. For example "*Could not resolve(2) job.customer : <NameOfTheSmartNameThatFails>/*"

### Step 5 - Add automation by starting this workflow from an Access Point

When an external system sends you a XML files describing Jobs to create, we advise to automate this workflow.

A typical way to do this is to create a **Folder Access Point**. The folder of that **Folder Access Point** is then the place where the XMLs will arrive. The workflow that the **Folder Access Point** will automatically start at a regular time interval is then the one you created in this example.



**Note:** Learn more on setting up such automation in [Folder Access Point](#) on page 1780.





**Attention:** It is also common for external systems to send the prepress department you an XML file containing the description of **multiple job orders**. And often those systems only send such a list once or twice per day. This use case is explained in a next example [Creating Multiple Jobs from One XML](#) on page 1867.

## 24.8.2. Creating Multiple Jobs from One XML

### Summary



**Note:** This example requires you to master the features explained in the previous example [Creating a Job using XML](#) on page 1858.

You receive an XML from the business system. It is a list of job-orders and their production parameters. Some are already started in prepress, some are new, some are on hold. Your goal is to create Jobs of all those in the status 'ReadyForPrepress'. The XML needs to be split into multiple XML files each describing one Job. These XML files are then input files for the **Create Job** task. The job-order info in the XML files is too elaborate. You will only pick up some selected parameters from those XML files.

Tools used in this example:

- **SmartNames** including **Xpath Builder**
- **Split XML** task
- **Data Splitter** workflow control
- **Create Job** task

### Step 1 - Analyze the XML describing Multiple Jobs



**Tip:** Click [this link](#) to download a ZIP with the sample XML file used in this example.

The XML in this example describes the 3 job orders. See how 2 of them have the status 'ReadyForPrepress'.

```
<?xml version="1.0" encoding="UTF-8"?>
- <Jobs>
  - <Job>
    <OrderID>1404-W86203</OrderID>
    <SubOrderID>003</SubOrderID>
    <Name>1404-W86203</Name>
    <Description>Promo strawberry 100ml South Europe</Description>
    <DueDate>2015-06-01T08:00:00.00Z</DueDate>
    <Status>ReadyForPrepress</Status>
    <ProjectID>Project193</ProjectID>
    <CustomerID>2712</CustomerID>
    <Category>flexo</Category>
    <CustomField1>Nilpeter FB-2500</CustomField1>
    <CustomField2>White BOPP</CustomField2>
  </Job>
  - <Job>
    <OrderID>1404-W74536</OrderID>
    <SubOrderID>002</SubOrderID>
    <Name>1404-W74536</Name>
    <Description>New flavour Cocos and lemon </Description>
    <DueDate>2015-06-01T08:00:00.00Z</DueDate>
    <Status>OnHold</Status>
    <ProjectID>Project123</ProjectID>
    <CustomerID>2712</CustomerID>
    <Category>flexo</Category>
    <CustomField1>Gallus ECS 340</CustomField1>
    <CustomField2>OPP</CustomField2>
  </Job>
  - <Job>
    <OrderID>1404-W74599</OrderID>
    <SubOrderID>009</SubOrderID>
    <Name>1404-W74599</Name>
    <Description>New flavour Banana</Description>
    <DueDate>2015-06-01T08:00:00.00Z</DueDate>
    <Status>ReadyForPrepress</Status>
    <ProjectID>Project123</ProjectID>
    <CustomerID>2712</CustomerID>
    <Category>flexo</Category>
    <CustomField1>Gallus ECS 340</CustomField1>
    <CustomField2>OPP</CustomField2>
  </Job>
</Jobs>
```



**Note:** In this example XML, we removed typical extra parameters about the customer, barcode and inks. The principle of those types was already explained in [Creating a Job using XML](#) on page 1858.



**Attention:** If you send this XML to the **Create Job** task, it would only create the first Job it finds in the XML.

## Step 2 - Create the Workflow Ticket

This is the workflow we need:



- The **Split XML** task splits the XML into multiple XML files. If you don't do this, the **Create Job** task would only create the first Job it finds in the XML.
- The **Data Splitter** makes sure the next task sees the many input files. It prevents that the task is only launched on the first input file.
- The **Create Job** task creates Jobs, as determined in the **Data Splitter**, for *each* incoming XML file.



**Note:** The **Create Job** has no output files. If you want to continue the workflow with its input files (the split XML files), then configure a specific **output pin** for that. Learn more on these possibilities in [the Workflow Editor](#).

### Step 3 - Splitting the XML but also using a Filter on Status

In the **Split XML** task, we need this XPath Expression:

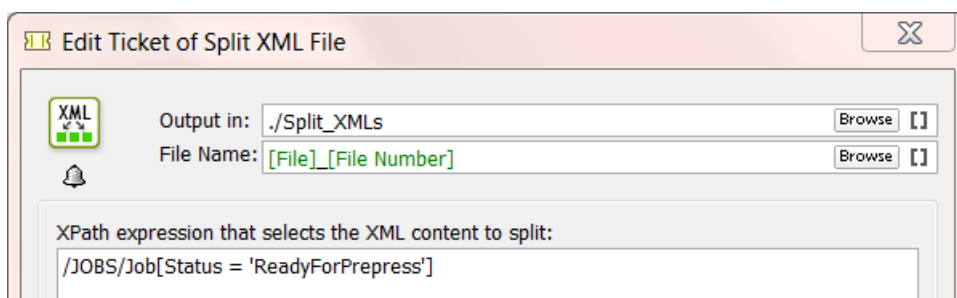

- The expression `/Jobs/Job` will result in splitting the XML on that level of elements: one per Job.
- The extra filter `[Status = 'ReadyForPrepress']` will limit that to jobs with that status.

This Xpath expression can easily be built by using the **Xpath Builder**. Open it via the **Edit** button.



**Note:** When the filter does not find any matching 'node'(job), the task will error and mention this as the reason.

- **Output in:** Define where you want the split XMLs to be written.
- **File name:** Define the name of the split XML(s). The default setting will add a number.

### Step 4 - Importance of the Data Splitter

When you do not use the **Data Splitter**, the **Create Job** task will receive all the XMLs generated by the **Split** task as 1 group on its input pin. In this case only the first incoming XML will be processed and the rest will be ignored. The **Data Splitter** step in this workflow will make sure the **Create Job** task receives the XMLs as separate files so each of them gets processed.

Because we (possibly) have multiple input XML files, we need these (default) settings:

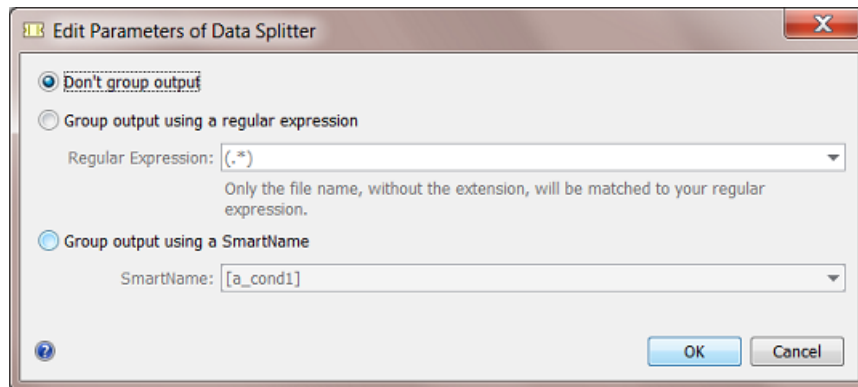

We do not want the split XML files to be grouped. The **Create Job** task needs to be launched on each one of them.

Find more details on this task in [Data Splitter](#) on page 835.

### Step 5 - Create the Xpath SmartNames

Identical as explained in the previous example [Creating a Job using XML](#) on page 1858, you need to

- create SmartNames that you will use in the **Create Job** ticket. As explained in [Step 2 - Create your SmartNames](#) on page 1859.
- insert those SmartNames in the **Create Job** ticket. As explained earlier in [Step 3 - Insert the SmartNames in the Create Job ticket](#) on page 1862.

### Step 6 - Workflow Result

Select the XML describing multiple Jobs and launch your workflow.

The **Create Job** task will be started per incoming XML. In this case 2 times, because only 2 had the status 'ReadyForPrepress'.

File Name	Task Type	Progress	Phase	State	Launched
Job Orders today_2.xml	Create Job	100%		✓	7/11/14 2:49 PM
Job Orders today_1.xml	Create Job	100%		✓	7/11/14 2:49 PM
Job Orders today.xml	Split XML File	100%		✓	7/11/14 2:49 PM
<b>Job Orders today.xml</b>	<b>Workflow</b>	<b>100%</b>		!	<b>7/11/14 2:49 PM</b>



**Note:** Workflow controls like the **Data Splitter** do not appear in this task overview.

See the files the workflow created:

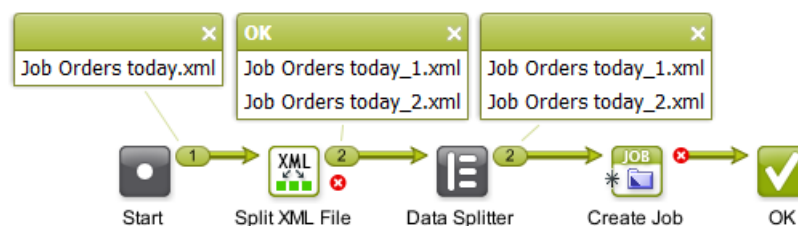

The 2 Jobs that had the status 'ReadyForPrepress' will be created:

Name	Description	Due Date	Order ID	Sub Order ID	Customer Name
1404-W86203_003	Promo strawberry 100ml South Europe	Jun 1, 2015	1404-W86203	003	FruitCo
1404-W74599_009	New flavour Banana	Jun 1, 2015	1404-W74599	009	FruitCo

### 24.8.3. Create Multiple Jobs from a CSV file

#### Summary

Every morning, you receive a CSV file from the planning department with a list of job orders for the prepress department. Each row in the CSV represents a job order. This data needs to be converted into separate XML files to send to the **Create Job** task.



**Note:** a CSV is a Comma Separated Value file. This is usually an exported file from a database or an XLS file.

Tools used in this example:

- **SmartNames** including **Xpath Builder**
- **Map Data** task
- **Split XML** task
- **Data splitter** workflow control
- **Create Job** task

#### Step 1 - Analyse the CSV file



**Tip:** Click [this link](#) to download a ZIP with the sample CSV file used in this example.

Our example CSV contains a description of 2 job orders.

	A	B	C	D	E	F	G	H	I	J
1	Order Nr	Customer	Customer Nr	DueDate	CSR email	Country	Process	Shipping	Preflight	Proof
2	EXA_CSV_Job01	FruitCo	2712	30-09-14	Franky.fruit@fruitco.com	USA	Flexo	Fedex		Web
3	EXA_CSV_Job02	Toy Dream	1965	25-10-14	Tony.Toy@Toydream.com	China	Offset	DHL	Yes	PDF

Because the **Create Job** task does not work with CSV files, we first need to create an XML. And as you saw in the previous example [Creating Multiple Jobs from One XML](#) on page 1867, we will need 1 XML per Job to create.



**Note:** At this point it is good to detect any data fields that will need reformatting. In this example workflow, the format of the due date will need to be mapped to the format that is required for that field in the Job Setup.

### Step 2 - Create the Workflow Ticket

This is the workflow that we need to create Jobs from a CSV with descriptions of multiple job orders:



- The **Map Data** task defines what parts of the CSV will be mapped into the XML file.
- The **Split XML** task splits that XML into multiple XML files, like we did in the [previous example](#).
- The **Data Splitter** makes sure that the next task sees the many input files. It prevents that the task is only launched on the first input file.
- The **Create Job** task creates Jobs, one for *each* incoming XML file.

### Step 3 - Mapping the CSV to XML

The **Map Data** ticket will

- convert the CSV to XML
- define which parts of the CSV are needed in the XML
- define how the parameters should be named in the XML. You can keep their names if you want to.
- define what part in the XML will be **Repeating Content**. This is needed because you are not sure how many jobs there will be in that CSV / XML. The CSV that you receive tomorrow can have a different amount of rows. This is the 'for each' principle as explained earlier in [Specifying the Output File](#) on page 1822.

 **Note:** The *order* in which we define the settings in this ticket is important.

#### 1. Define the CSV as input file

- Select your CSV file and open the workflow ticket that you made in the previous step.
- Double click the **Map Data** step. This automatically sets your CSV as input file:

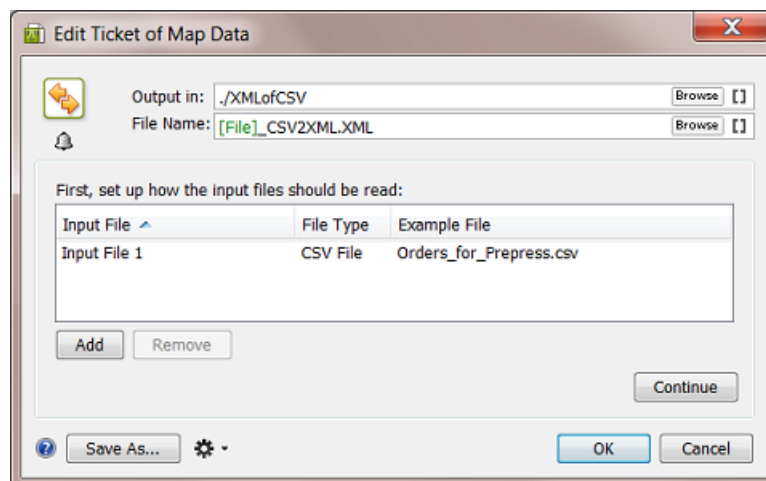

- Now set 2 specific options that define how our example CSV should be read. Double click the line 'Input File 1' to open its setup. Set the **Field Separator** to **Semicolon**. Because the first line of the CSV contains the field headers (not values we want to read), check the option **Ignore first line**. Remember that your specific CSV might be different, so do check all options.

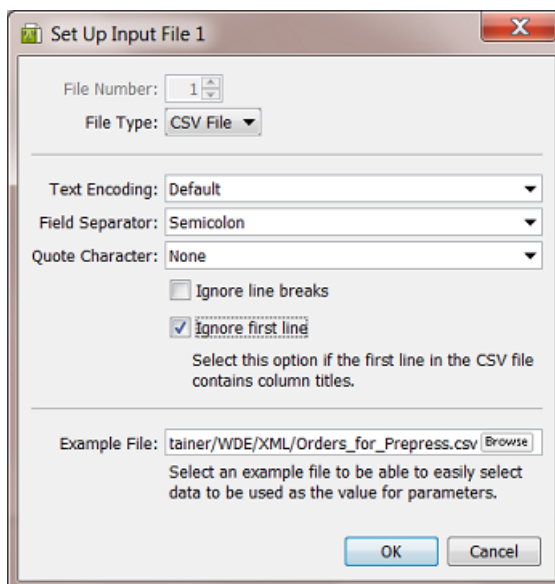

- Click **OK** to close that dialog.
- Maybe now is a good time to already define the folder and name of your output XML. As usual, you can use SmartNames in **Output in:** and **File Name:**.
- Click **Continue**.
- Make sure the **Output Format:** is on 'XML'. In the **Options...** make sure to activate the **Replace reserved characters in parameter values with XML entities**. In this example, there are no such characters.

## 2. Define the Repeating Content in the XML



**Note:** Make sure you have already read [the chapter documenting this advanced technology](#).

This ticket allows many ways to use it. Following steps are specific for this CSV to XML workflow:

In the **Map Data** ticket, in the canvas where you define the output XML,

- Right-click and choose **Insert XML Declaration**. This is just good practice when creating XML.
- Right-click and choose **Insert Element**. Give it a logical names, for example <Jobs>
- Put your cursor in between the open and closing element, right-click and choose **Insert Repeating Content** (or click on + ≡).



**Remember:** You can not make any existing content 'Repeating' *later*; you need to create the 'Repeating Content' block *first* and then add content inside.

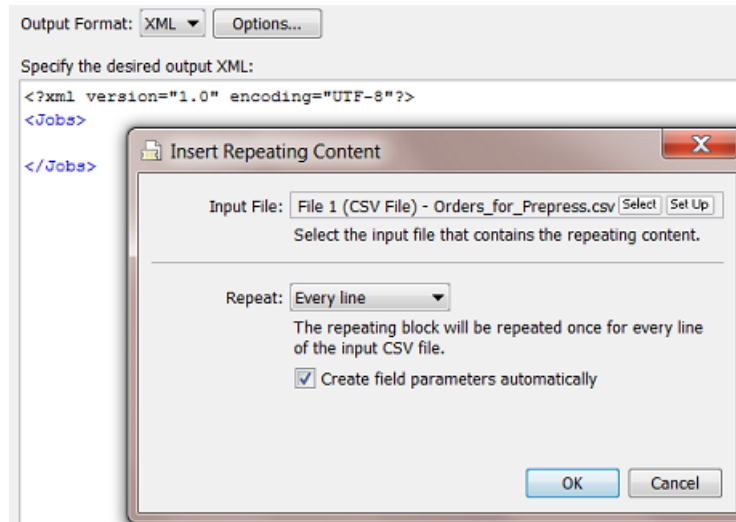

Every line (row) in your CSV represents a job order. So you do want **Every line** in your CSV to become the Repeating Content. Remember we already decided to ignore the first line of the CSV.

- Click OK. A pink field for **Repeating Content** is created. Also the field parameters were created automatically. They are colored pink because they are linked to the selected **Repeating Content** field.

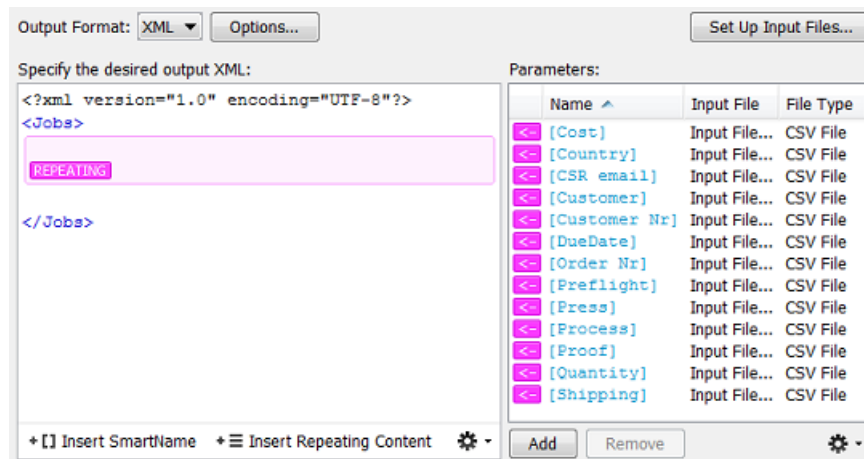

- Now, inside that **Repeating Content** field, continue specifying the content of the XML. Insert Elements and click the pink parameters in between the opening and closing element.



**Attention:** Make sure your XML elements do not contain spaces!

This is a basic and valid example:



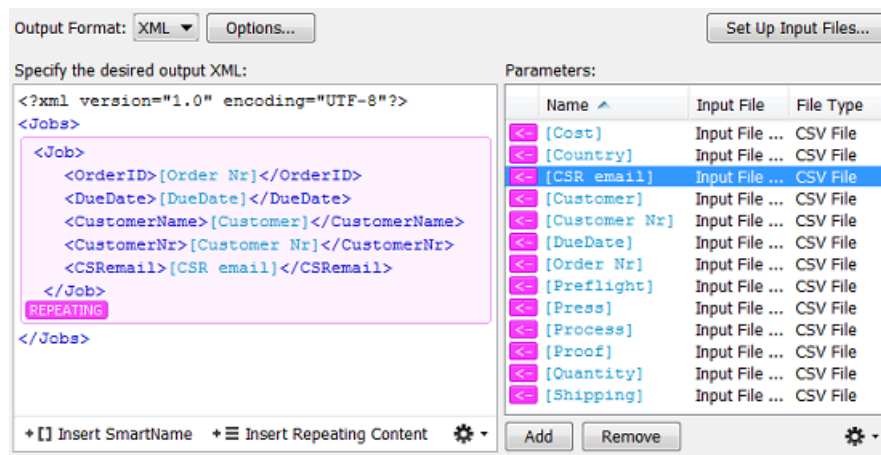

You can see we only use 5 of the parameters in this example. You can of course pick up a lot more.



**Note:** Remember that the XML file will just be an in-between format. You will later, in the **Create Job** ticket, still map the XML elements to the real fields in the Job Setup.

- Click **OK** to close the set up of your **Map Data** ticket.
- Save your Workflow ticket. No need to close it.

### Step 4 - Test your CSV to XML Mapping

We advise to already test what we set up in our **Map Data** ticket. Because if that output does not look good, it is better to correct that now instead of using a wrong XML file as input for the next workflow steps.

With the CSV as input file, launch the workflow. Because we haven't defined the settings for the next workflow steps yet, the workflow will surely fail.

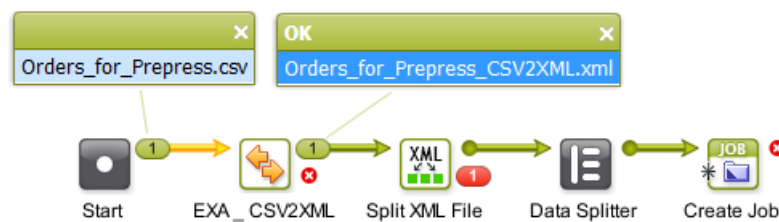

You now see that your CSV was mapped to an XML. Double click the output file to open it. It should look like this:

```
<?xml version="1.0" encoding="UTF-8" ?>
- <Jobs>
- <Job>
  <OrderID>EXA_CSV_Job01</OrderID>
  <DueDate>30-09-14</DueDate>
  <CustomerName>FruitCo</CustomerName>
  <CustomerNr>2712</CustomerNr>
  <CSRemail>Franky.fruit@fruitco.com</CSRemail>
</Job>
- <Job>
  <OrderID>EXA_CSV_Job02</OrderID>
  <DueDate>25-10-14</DueDate>
  <CustomerName>Toy Dream</CustomerName>
  <CustomerNr>1965</CustomerNr>
  <CSRemail>Tony.Toy@Toydream.com</CSRemail>
</Job>
</Jobs>
```

You see

- the main structure `/Jobs/Job`
- the description of the 2 Jobs,
- including the 5 parameters that we picked up from their definition in the CSV.

When your XML is not OK, then solve the problem first before defining the next workflow steps.

### Step 5 - Set up the Split XML step

- Leave the workflow ticket and go back to your Pilot.
- Go to the folder where you wrote the output of the **Map Data** ticket and select the `Orders_for_Press_CSV2XML.XML`
- Open the default **Split XML** ticket. Your XML will be seen as input file.
- Click **Edit** to open the **Xpath Builder**.
- Click on a `Job` node

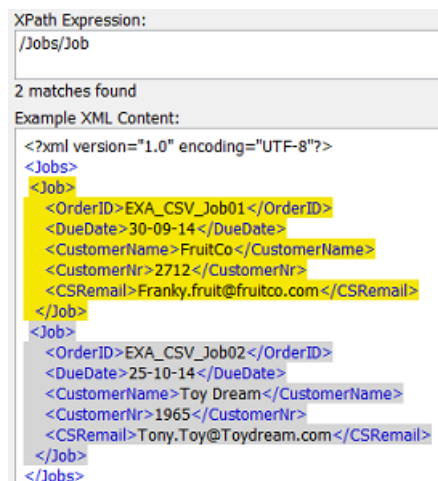

The resulting Expression will be shown above: `/Jobs/Job` .

- Click **OK** to close the dialog.

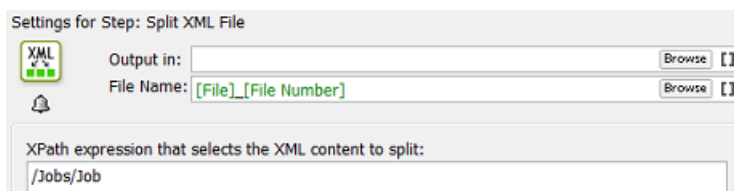

- Your ticket is ready. Save it with a logic name.
- Open your workflow and replace the default **Split XML** step with this specific one.
- Save your workflow.

### Step 6 - Test your workflow again

- Select the CSV and launch your workflow. Because we haven't defined the settings for **Create Job** ticket yet, the workflow will surely fail.

What you now need to see is the 2 XMLs as output of the **Split XML** ticket.

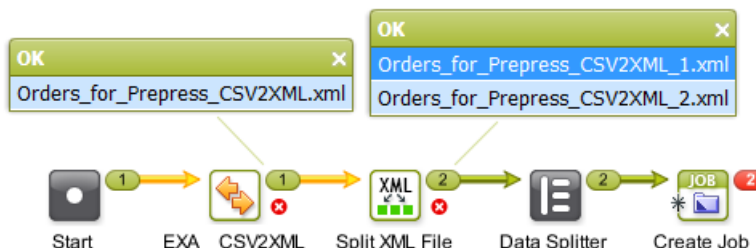

- Double-click one of the split off XML files to open it. It should look like this:

```
<?xml version="1.0" encoding="UTF-8" standalone="no" ?>
- <Jobs>
- <Job>
  <OrderID>EXA_CSV_Job01</OrderID>
  <DueDate>30-09-14</DueDate>
  <CustomerName>FruitCo</CustomerName>
  <CustomerNr>2712</CustomerNr>
  <CSRemail>Franky.fruit@fruitco.com</CSRemail>
</Job>
</Jobs>
```

### Step 7 - Check the Data Splitter

The **Data Splitter** control in your workflow should have the (default) settings to **'not group'**. Its purpose is identical as in previous example, where we explained [the importance of the Data Splitter](#).

### Step 8 - Defining the SmartNames for the Create Job ticket

Making the SmartNames and inserting them into your **Create Job** ticket is not different here than explained in earlier examples, like in [Step 2 - Create your SmartNames](#) on page 1859 and [Step 3 - Insert the SmartNames in the Create Job ticket](#) on page 1862. We will first briefly recapitulate that part and then we will pay extra attention to setting up the SmartName for the Due date.

### Creating the necessary SmartNames

Follow these steps to create the SmartNames:

- In your **Pilot**, go to the **SmartNames** tool.
- On the right, in **Resolve all using:**, select **A file:** and browse to one of the split off XML files (for example *Orders\_for\_Prepress\_CSV2XML\_1.xml*).
- Create Xpath Query SmartNames for
  - OrderID
  - CustomerName
  - CustomerID
  - CSRemail

### Creating the SmartName for the Due Date

- In your **Pilot**, go to the **SmartNames** tool.
- Click on  to create a New SmartName.
- Choose the type : Xpath Query.
- Click on **Edit**. In the XPath Builder, select the value for the element *DueDate*.

```

XPath Expression:
/Jobs/Job/DueDate/text()

1 match found
Example XML Content:
<?xml version="1.0" encoding="UTF-8" standalone="no"?>
<Jobs>
  <Job>
    <OrderID>EXA_CSV_Job01</OrderID>
    <DueDate>30-09-14</DueDate>
    <CustomerName>FruitCo</CustomerName>
    <CustomerNr>2712</CustomerNr>
    <CSRemail>Franky.fruit@fruitco.com</CSRemail>
  </Job>
</Jobs>
    
```

- In the setup of an Automation Engine Job, the due date needs to be specified according the ISO 8601 standard. We therefore need to reformat that date from how it was defined in the CSV ('30-09-14'). Now set the formatting options as follows (see screen shot below):
  - Click on **Formatting Options....**
    - Set the **Data Format** to **Date and Time**.
    - Set the **Format** to **ISO 8601**.
    - Choose your **Time Zone** (the one of your Automation Engine server).

Below left in the dialog, you will see that the **Result** is still not OK.
  - Click on **Input Format Options....**
    - Set the **Format** to **Custom**.
    - Set the **Language**.

- Choose **Custom Format**. Now write how your data was formatted in the CSV: dd-MM-yy.



**Attention:** The month is here defined by an 'M' in capitals! A lowercase 'm' will be seen as minutes!

- Click **OK**. The correct result should now be visible in the **Formatting Options** dialog.

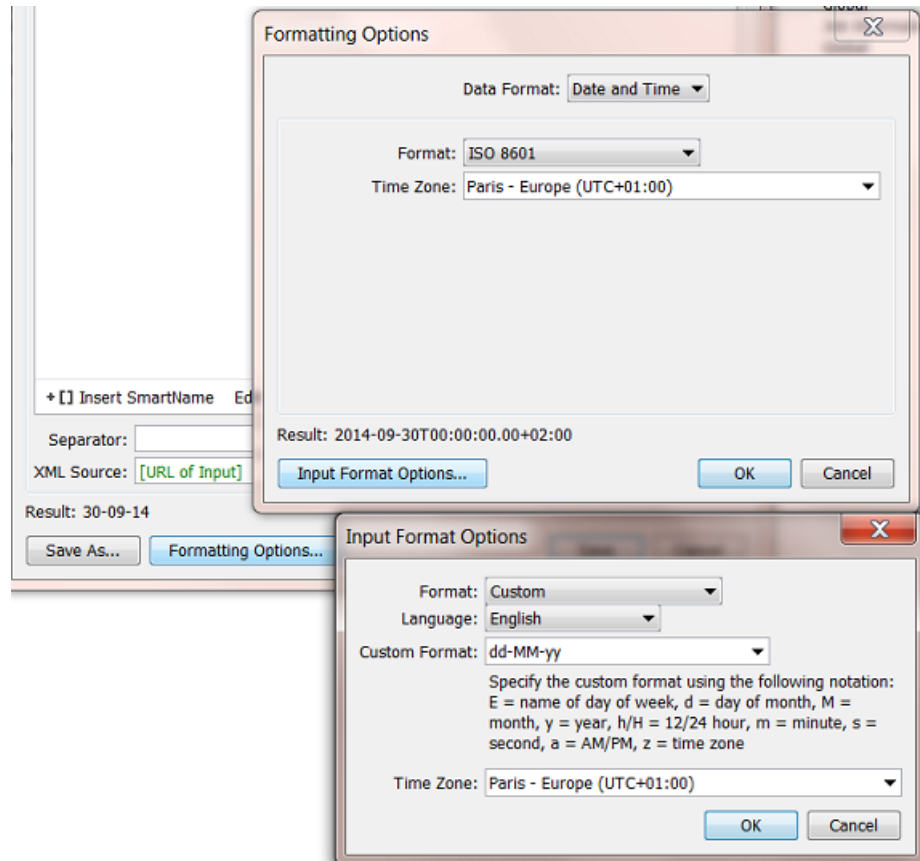

Now save your SmartName and give it a logic name. For example "From XML - CSV Due date for ISO".

### The resulting Create Job ticket

- Open the workflow and double-click the **Create Job** ticket.
- Add your SmartNames. It could look like this:

Job	Customer	Inks	Parameters	Bar Codes	Template	Advanced
Order ID:	[EXA XML OrderID]					[ ]
Sub Order ID:						[ ]
Name:						[ ]
Description:						[ ]
Due Date:	[From XML - CSV Due date for ISO]					[ ]
Project ID:						[ ]
Category:						[ ] ▼
Printing Press:						[ ] ▼
Substrate:						[ ] ▼
Job Folder:	it/Automation Engine/Public/demo_container/[EXA XML OrderID]					[Browse] [ ]

Job	Customer	Inks	Parameters	Bar Codes	Template	Advanced
Customer ID:	[EXA - XML Customer ID]					[Select] [ ]
Customer Name:	[EXA - XML Customer]					[ ]
Customer Description:						[ ]
Customer's Job Reference:						[ ]
Customer Service Representative:						[ ] ▼
E-mail:	[XML CSR Email]					[ ]

- Now save your workflow ticket.

### Step 9 - Workflow Result

In the **Pilot**, select your CSV file and launch your workflow. It will look like this:

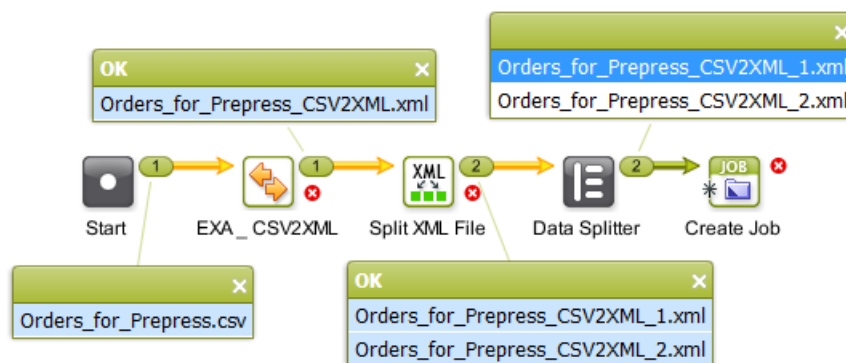

It will have created these 2 Jobs:

Jobs			
Name	Order ID	Customer Name	Due Date
EXA_CSV_Job02	EXA_CSV_Job02	Toy Dream	Oct 25, 2014
EXA_CSV_Job01	EXA_CSV_Job01	FruitCo	Sep 30, 2014

## 24.8.4. Creating Jobs using a Database Access Point

### Summary

We will use a **Database Access Point** to query an external database (one from a business system where the job orders originate). The query will, at a regular time interval, ask that database which new Jobs need to be created on Automation Engine. The result of this query are XML files with the description of those Jobs. Those XML files will be used to create the Jobs (as shown in [previous examples](#)).

Tools used in this example:

- An external database
- A **Database Access Point**
- **SmartNames** including **Xpath Builder**
- The **Data Splitter** workflow control
- The **Create Job** task

### Step 1 - Analyse the External Database



**Tip:** Click [this link](#) to download a ZIP with the sample database used in this example.

This is the database we will query in this example:

OrderNr	CustomerName	CustomerID	DueDate	ProofType	Status	Process	Press	Quantity
1234	ToyDream	1965	30-09-14	Web	Shipped	Flexo	F1	200000
1235	Graceland	6666	27-12-14	FTP-PDF	Ready For Prepress	Screen	S3	250000
1236	FruitCo	2712	11-10-14	HardCopy	Ready For Prepress	Flexo	F1	420000
1237	FruitCo	2712	02-12-14	HardCopy	Ready For Prepress	Flexo	F1	160000
1238	ToyDream	1965	07-09-14	Web	On Hold	Flexo	F1	32000
1239	ToyDream	1965	23-11-14	Web	NULL	Offset	O4	7500
*	NULL	NULL	NULL	NULL	NULL	NULL	NULL	NULL

- The database software type is a MS SQL server.
- It runs on a server computer named EAW11DL306.
- The name of the database that we will access is MyExternalSystem (there could be more served by this same software).
- The name of the (opened) table is MyOrders.

- The table contains the description of 6 job orders.
- The Status column shows that 3 job orders are 'Ready For Prepress'. Those are the ones that we want to create on Automation Engine.

### Step 2 - Configure the Link to the External Database

Set up the link with the external database. This is done in via **Tools > Configure > External Databases**. Learn more on such configurations in [External Databases](#) on page 197.

For this example, this is the configuration we need:

The screenshot shows a configuration window for an external database. It includes the following fields:

- DBMS Type: Microsoft SQL Server (dropdown)
- Database: MyExternalSystem
- Host: eaw11dl306
- Port: (empty)
- User: admin
- Password: (masked with dots)
- Test Connection button

### Step 3 - Set up the Database Access Point



**Note:** Setting up **Database Access Points** is documented in [Creating or modifying a Database Access Point](#) on page 1792.

This is an example of the Access Point we need:

The screenshot shows the 'Modify Database Access Point' dialog box with the following configuration:

- Name: Get Jobs From MIS DB
- Description: (empty)
- Database Settings tab selected
- External Database: MyExternalSystem
- SQL Select Query: `SELECT OrderNr, CustomerName, CustomerID, DueDate, ProofType, Process, Status FROM MyOrders WHERE Status = 'Ready For Prepress'`
- After Processing:  Update the records
- Table for column updates:
 

Column Name	New Value
Status	InPrepress
- Buttons: Add, Remove, Edit, OK, Cancel



- In the **Pilot**, create a new **Access Point** and choose the type **Database**.
- Give it a logical **Name** and **Description**.

### Database Settings

- Select the **External Database** you configured in the previous step.
- Enter the **SQL Select Query**:
  - 'SELECT' indicates which columns you want to get a value from.
  - 'FROM' indicates the database *table* where these columns are.
  - 'WHERE' indicates an extra filter: you do not want *all* the jobs from that table, but only those with the status 'Ready For Prepress'.



**Note:** SQL queries are case-sensitive!



**Note:** It is possible to select values from different tables, for example if you want to get more details about the customer or about production tools. This examples does not do that.



**Note:** Esko does not offer training or support in database queries. This is mentioned in [Concept of tasks interacting directly with external systems](#) and [Concept of the Interact with Database task](#).

- **After Processing:** We here use **Update the records** to change the status field in the external database to 'InPrepress'. This is necessary to avoid that, after the next time interval, these jobs would be created/updated again (because they would still be in the status 'Ready For Prepress'.)



**Tip:** You can choose to not do this status-update here but rather wait until the workflow really has created the **Job**. In the following workflow, you can then use an extra **Interact with Database** ticket to update that status in the external database with for example a status 'Job Created and Started in Prepress'.

### Monitoring

Define the time interval with which the query should be done.



**Note:** There is no need to set it to '1 minute' to make testing easier. See further how we will use the **scan now** button instead.

### Automatic Actions

The query will write an XML file **for each** job order that it finds in the specified status.

- **Move Files to:** Define where you want those XML files to be written. The Job they represent does not exist yet so we advise to write them in some central folder. See an example in the screen shot.
- **Rename Files to:** Their default name [File] actually consists of [table\_name]\_[date-and-time]. You can overrule this or add more SmartNames. Also see later when we show the result.
- **Action:** We will add a workflow in later steps of this example. For the moment, leave this to None.

**Click OK to confirm your settings**

Your **Database Access Point** now exists.

**Activate the Access Point**

Right-click and choose **Activate Access Point**.

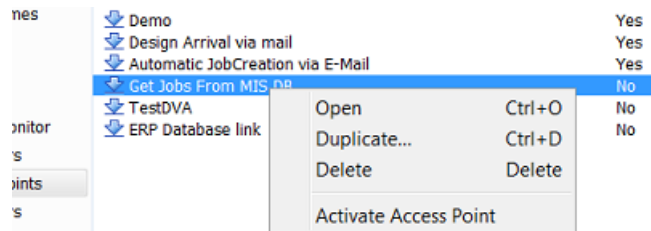

**Step 4 - Test your Database Access Point**

Select your **Database Access Point** and click the button to **scan now**.

This will execute the SQL query immediately.

An **Alert** window will appear with the result. In our example, we see

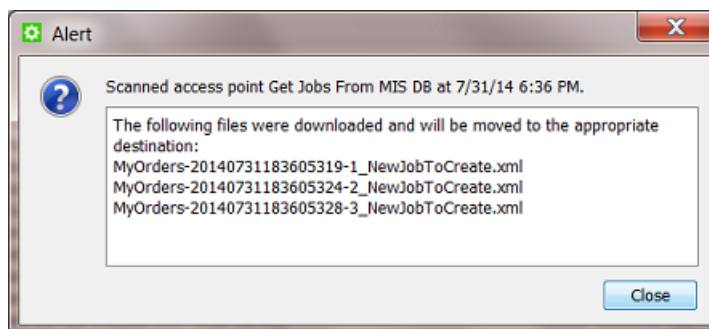

- 3 XML files were created because 3 job orders had the status that we were asking for: 'Ready For Prepress'.
- Their name is the result of the SmartNames as explained in the previous step.

**This is one of the resulting XML files:**

```
<?xml version="1.0" encoding="UTF-8" ?>
- <MyOrders created="2014-08-01T12:52:56.928+02:00" producer="DBPoller-MyExternalSystem"
  select="SELECT OrderNr, CustomerName, CustomerID, DueDate, ProofType, Process, Status
  FROM MyOrders WHERE Status = 'Ready For Prepress'">
  <OrderNr>1235</OrderNr>
  <CustomerName>Graceland</CustomerName>
  <CustomerID>6666</CustomerID>
  <DueDate>27-12-14</DueDate>
  <ProofType>FTP-PDF</ProofType>
  <Process>Screen</Process>
  <Status>Ready For Prepress</Status>
</MyOrders>
```

See how the XML file contains the query that was used.

These XML files will now be used as input files to create Jobs.

### Check the new status in the database

Remember the [Update the records setting in previous step](#). See how, for the 3 job orders that first had the status 'Ready For Prepress', the status has now changed to 'InPrepress':

EAW11DL306.MyEx... - dbo.MyOrders Summary									
	OrderNr	CustomerName	CustomerID	DueDate	ProofType	Status	Process	Press	Quantity
	1234	ToyDream	1965	30-09-14	Web	Shipped	Flexo	F1	200000
▶	1235	Graceland	6666	27-12-14	FTP-PDF	InPrepress	Screen	S3	250000
	1236	FruitCo	2712	11-10-14	HardCopy	InPrepress	Flexo	F1	420000
	1237	FruitCo	2712	02-12-14	HardCopy	InPrepress	Flexo	F1	160000
	1238	ToyDream	1965	07-09-14	Web	On Hold	Flexo	F1	32000
	1239	ToyDream	1965	23-11-14	Web	NULL	Offset	O4	7500



**Attention:** When testing this **Access Point**, do remember that every time you run it that the status of those job orders will change to 'InPrepress'! This means that the next time the **Access Point** will do nothing simply because there are no more job orders in that database with the required status 'Ready For Prepress'! So, in between tests, you have to manually reset those statuses to 'Ready For Prepress'. And remember that the queries are case-sensitive!

### Step 5 - Create your SmartNames

Identical to how we did this in [step 2 of the first example](#), we will now create the SmartNames that will map the fields in the XML to the Job setup fields in the **Create Job** task.

1. In the Pilot, go to the **SmartNames** View.
2. On the right, in **Resolve all using:**, check the button for **A file** and browse to one of the XML files you created in the previous step.
3. Click on **Create a New SmartName**.
4. In the dialog, indicate the type **Xpath Query**.
5. Click on **Edit** to open the **Xpath Builder**.
6. In the XML content, highlight the first value you want to make a **SmartName** for. For example OrderNr.

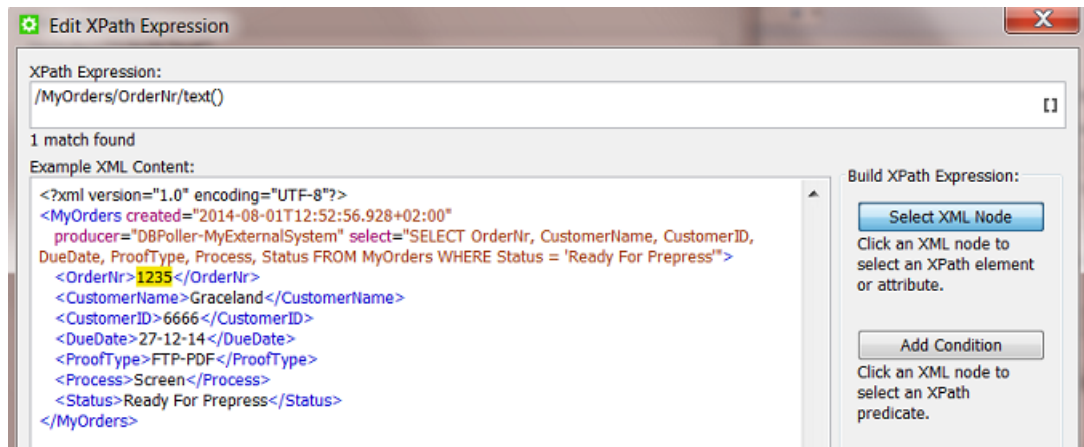

The resulting **Xpath Expression** will appear.

7. Click **OK**.

You will see the result value 1235 appear bottom left in **Result:** .

8. Click **Save As...** and give the new **SmartName** a logical name. For example EXA\_DB\_Myorders\_OrderNr.

9. Keep the dialog open and click again on **Edit**. Repeat steps 6 to 8 for the next **SmartNames** that you want to make in this example, **except the SmartName for the Due Date**, that one needs an extra formatting. See next step:

10. Creating the **SmartName** for due date is here identical to how we did it *in the previous example*. You need to make sure the output format is according the ISO standard for this Job setup field. And you need to indicate how the input is constructed. In our example this is dd-MM-yy.

11. When finished saving all **SmartNames**, close the dialog (press **Cancel** or use **Save** for your last **SmartName**)

12. Back in the **SmartNames View**, type a view filter that will only show your 5 new **SmartNames** and then click on **Show** (right panel)  
You should now see this:

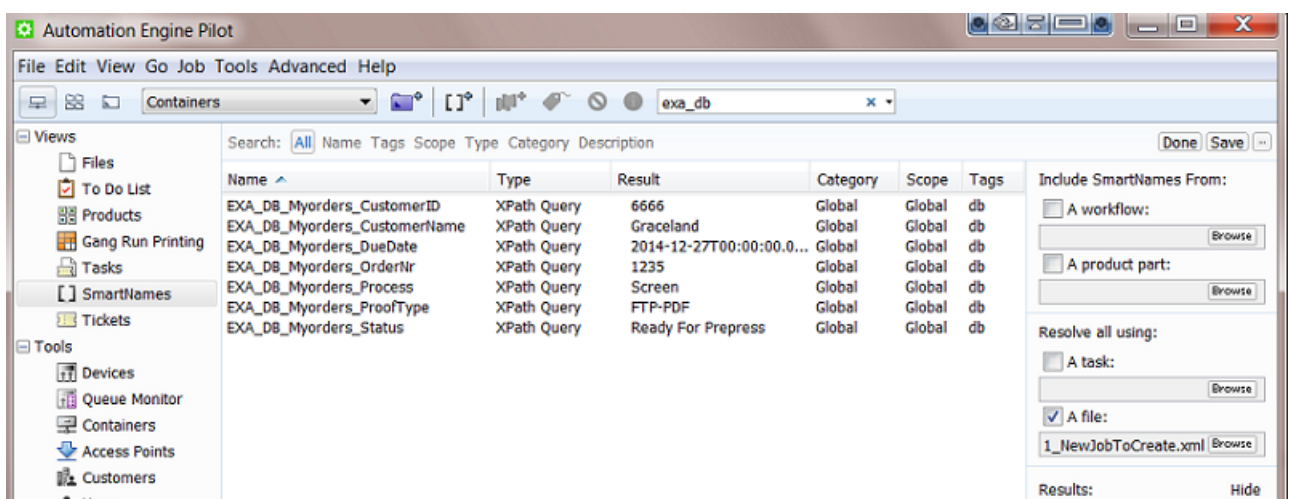

### Step 6 - Create the Workflow with the Create Job task

To have the Jobs created automatically, create this workflow:

1. In the **Pilot**, go back to the **Files** or **Job** mode and click on  to create a new **workflow**.
2. Build a workflow that starts with a **Data Splitter** (keep its default settings 'don't group output'), followed by a **Create Job** ticket.



3. Already save your workflow with a logical name. Remember we will later attach it to the **Database Access Point**.
4. Double click the **Create Job** ticket and add the **SmartNames** to their matching fields. It should look like this:

Job	Customer	Inks	Parameters	Bar Codes	Template	Advanced
Order ID:	<input type="text" value="[EXA_DB_Myorders_OrderNr]"/>					<input type="button" value="[]"/>
Sub Order ID:	<input type="text"/>					<input type="button" value="[]"/>
Name:	<input type="text"/>					<input type="button" value="[]"/>
Description:	<input type="text"/>					<input type="button" value="[]"/>
Due Date:	<input type="text" value="[EXA_DB_Myorders_DueDate]"/>					<input type="button" value="[]"/>
Project ID:	<input type="text"/>					<input type="button" value="[]"/>
Category:	<input type="text" value="[EXA_DB_Myorders_Process]"/>					<input type="button" value="[]"/> ▼
Printing Press:	<input type="text"/>					<input type="button" value="[]"/> ▼
Substrate:	<input type="text"/>					<input type="button" value="[]"/> ▼
Job Folder:	<input type="text" value="&lt;A_DB_Myorders_CustomerName&gt;/[EXA_DB_Myorders_OrderNr]"/>					<input type="button" value="Browse"/> <input type="button" value="[]"/>

The **Job Folder** setting in the screen shot is just an example of many ways to define it.

Job	Customer	Inks	Parameters	Bar Codes	Template	Advanced
Customer ID:	<input type="text" value="[EXA_DB_Myorders_CustomerID]"/>					<input type="button" value="Select"/> <input type="button" value="[]"/>
Customer Name:	<input type="text" value="[EXA_DB_Myorders_CustomerName]"/>					<input type="button" value="[]"/>
Customer Description:	<input type="text"/>					<input type="button" value="[]"/>
Customer's Job Reference:	<input type="text"/>					<input type="button" value="[]"/>
Customer Service Representative:	<input type="text"/>					<input type="button" value="[]"/> ▼
E-mail:	<input type="text"/>					<input type="button" value="[]"/>

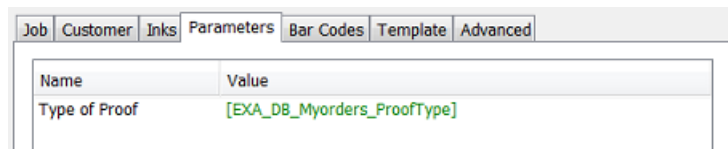

5. Save your workflow.

### Step 7 - Test your workflow

In your **Pilot**, go to that (central) folder where your 3 XML files were written. Select these 3 input files and launch your workflow.

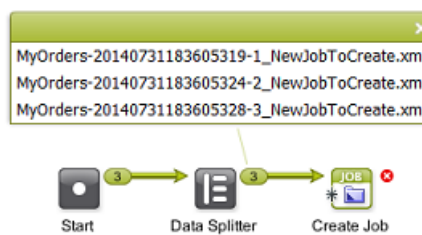

See how the **Data Splitter** receives 3 XML files and hands them over one by one to the **Create Job** ticket that creates these 3 Jobs:

Jobs				
Name	Order ID	Customer Name	Customer ID	Due Date
1235	1235	Graceland	6666	Dec 27, 2014
1236	1236	FruitCo	2712	Oct 11, 2014
1237	1237	FruitCo	2712	Dec 2, 2014



**Tip:** Also check again if the due dates are formatted correctly.

### Step 8 - Add the workflow to the Access Point and test again

Open your **Database Access Point**. In **Action**, choose **Launch Workflow** and select your workflow. Click **OK** to confirm.

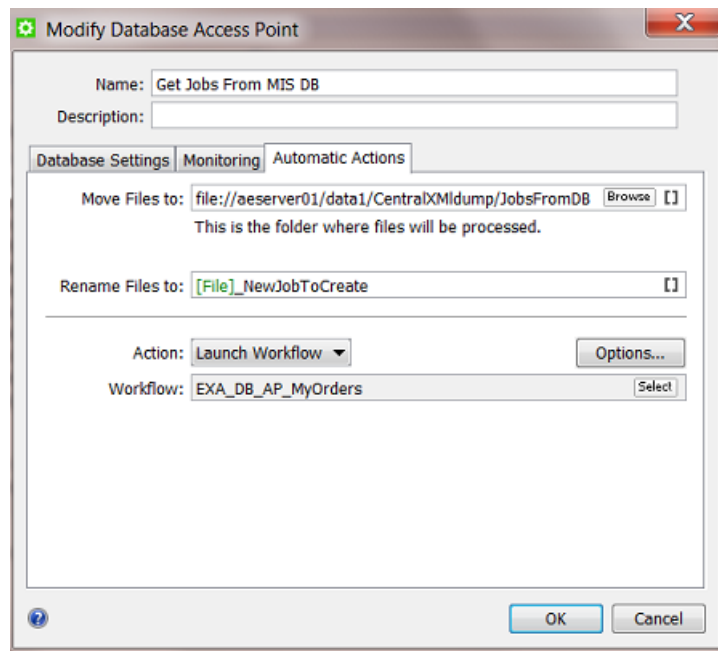

According to the set time interval, your **Database Access Point** will run and now also use its resulting XML files as input files for your workflow.

When your **Database Access Point** is selected, you see the workflow task appear:

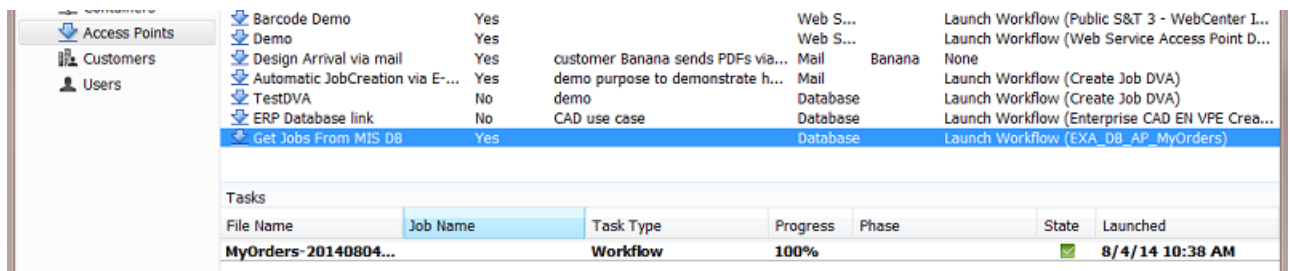

### 24.8.5. Launching a workflow with parameters from an XML

#### Summary

A workflow is automatically launched when the business system writes an XML file on a **Folder Access Point**. The **XML file describes what to do with what file**: it contains a full path to a new design file and describes many parameters that will be used as **Workflow Parameters** in the workflow that will be launched.

Such a concept is used by business systems that trigger a workflow on Automation Engine based on a new status. For example: when the business system notices that the status of a job order changes to 'Design Arrived', it decides to already start a prepress workflow on Automation Engine (the one that is typical for new designs from that customer). It is also common that such setups are not limited to only one status leading to one workflow. Some customers elaborate on this process and have 2 or 3 such links between a status in the business system and an automatically launched workflow on Automation Engine.

Tools used in this example:

- **SmartNames** including the **Xpath Builder**
- **Workflow Parameters**
- A **Folder Access Point**
- These tasks: **Preflight with PitStop, Create Report (ReportMaker), Zip, Send E-mail, Upload via FTP**
- These workflow controls: **Select Referenced File, Router, Data Collector.**



**Note:** In this example we do **not use** Automation Engine's **Job concept**.



**Note:** This example assumes you are already comfortable making advanced workflows.

### Step 1 - Analyse the incoming XML



**Tip:** Click [this link](#) to download a ZIP with the sample XML file used in this example.

This is the type of XML file that we receive from the business system:

```
<?xml version="1.0" encoding="UTF-8" ?>
- <Prepress>
  - <Workflow >
    <OrderNr>196570</OrderNr>
    <Description>Shrek Promo South America</Description>
    <CustID>1965</CustID>
    <CustName>ToyDream</CustName>
    <CustContact>Tony Sueno</CustContact>
    <CustContactEmail>tony@toydream.com</CustContactEmail>
    <Status>StartPrepress</Status>
    <JobType>Display</JobType>
    <Design>file://AEsServer01/Data1/demo_container/MIS-XML-WFL DATA/Design Arrival/Shrek.pdf</Design>
  - <Preflight>
    <PreFlightYesNo>yes</PreFlightYesNo>
    <PreFlightProfile>CMYK Display</PreFlightProfile>
  </Preflight>
  <ReportCardYesNo>yes</ReportCardYesNo>
  <SendViaFTPorEMAIL>Email</SendViaFTPorEMAIL>
  <FTPFolder>ToyDreamFTP</FTPFolder>
</Workflow>
</Prepress>
```

In the XML file, notice

- the job order number and some customer details
- a absolute full URL to the design file that just arrived. The design is named 'Shrek.pdf'.
- some decisions if the workflow needs preflighting or creation of a report card.

### Step 2 - Create the Workflow

Now create the basic structure of our workflow. Add the steps as in the screen shot. We will add more detail later. It is possible that some of the connections can not be made yet.





Notice these main process steps:

- the workflow needs to run on the PDF, not on the incoming XML file that will land on the **Folder Access Point** (that we will create later in this example). That is why we will also use **Select referenced File** to select that 'Shrek.pdf' (see further).
- the workflow parameters will indicate whether the route to **Preflight with PitStop** and/or route to the **Create Report (ReportMaker)** needs to be taken.
- if the **Router** confirms that preflighting is needed, the step will do that and use a **Profile** defined in the XML.
- if the **Router** confirms that a design report card is needed, the **Create Report (ReportMaker)** will create that.
- the **Data Collector** collects the Preflight Report and/or the Design Report card, after which they are ZIP'ed together.
- the XML will indicate the next router if this ZIP needs to be sent to the customer via E-mail or via FTP.

Save your workflow with a logical name, for example EXA\_XML\_Workflow.

### Step 3 - Load Workflow Parameters from the XML

The XML files that the external system sends will always have the same elements, but with mostly different values. This is a typical case to use **Workflow Parameters**.



**Note:** Learn more about **Workflow Parameters** in [Using Workflow Parameters](#) on page 859.

1. Open the workflow you created and in the menu go to **Advanced > Manage Workflow Parameters**.
2. Check **Use values from XML file** and enter these SmartNames [URL of Folder of Input]/[File].xml (see also in below screen shot).
3. Click on **Load Workflow Parameters from XML...** (below right). Browse to your XML example file and click **Open**. Choose to **Leave blank to select all elements below the root element**. All the XML element names will be listed, with their value from in this specific example XML:

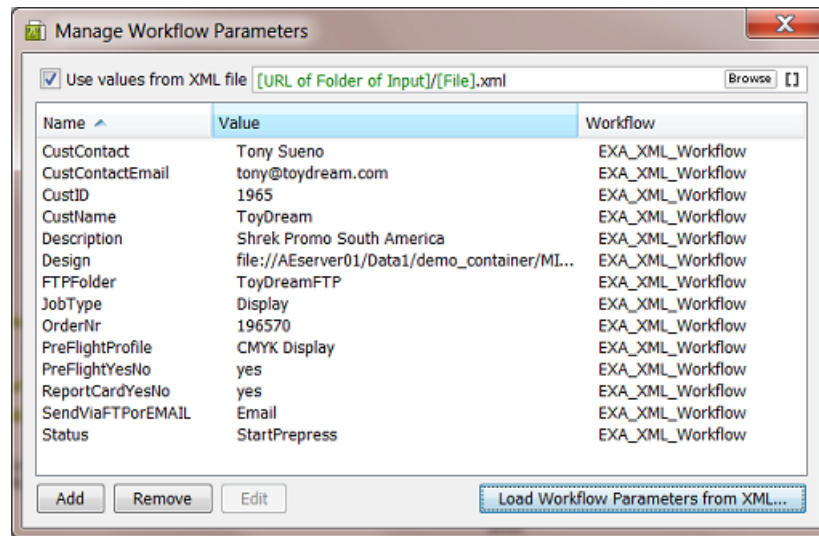

4. Click on **X** to close this dialog.  
 These parameters are now **Workflow Parameters**. Every time this workflow is launched, they will be "loaded" before even starting the first workflow step.
5. Save your workflow.

**Step 4 - Select the Design file that is Referenced in the XML**

The workflow needs to run on the design file, not on the XML file. The design file is referenced in the XML file.

1. In the **Pilot**, select the example input XML file and then open the workflow you created.
2. In the workflow, open the step **Select Referenced File**.
3. In **Select by:**, choose **File Path**.
4. In **File Path**, click on **Edit** to open the **Xpath Builder**.
5. In the **Xpath Builder**, the input XML file of your workflow will be shown as **Example XML Content**.

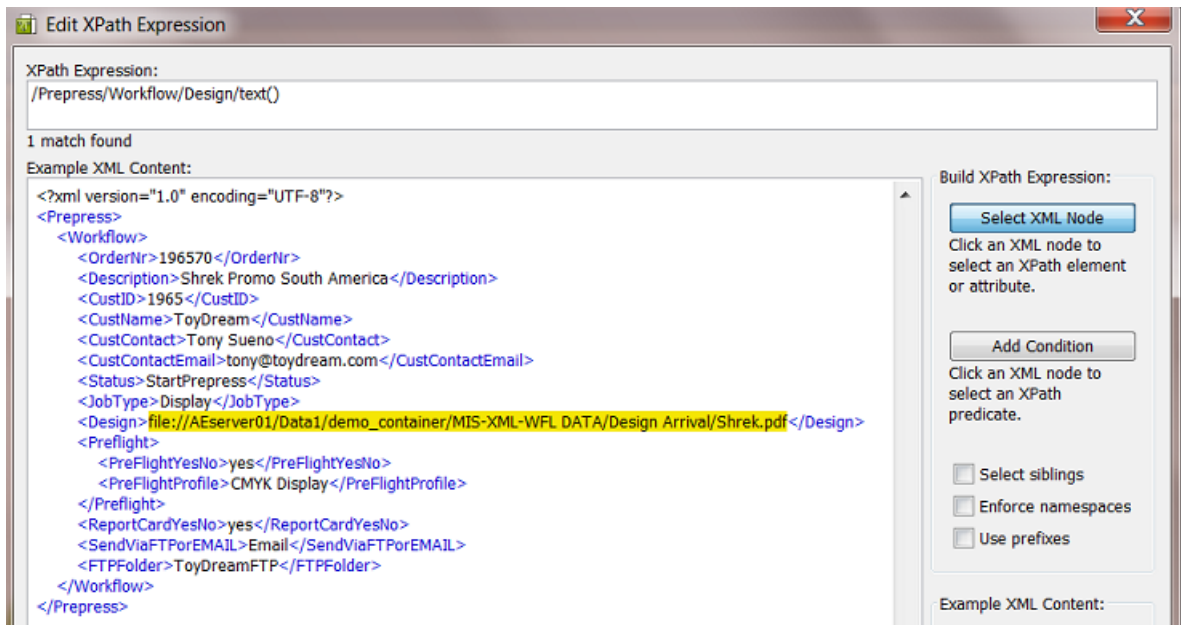

Select the path (the value of the *Design* element).  
On top, the resulting **Xpath Expression** will be shown.

6. Click **OK** to close the **Xpath Builder**.  
The **Xpath Expression** is now copied as **File Path**.
7. Check the option **Provide a warning when no files were selected**.

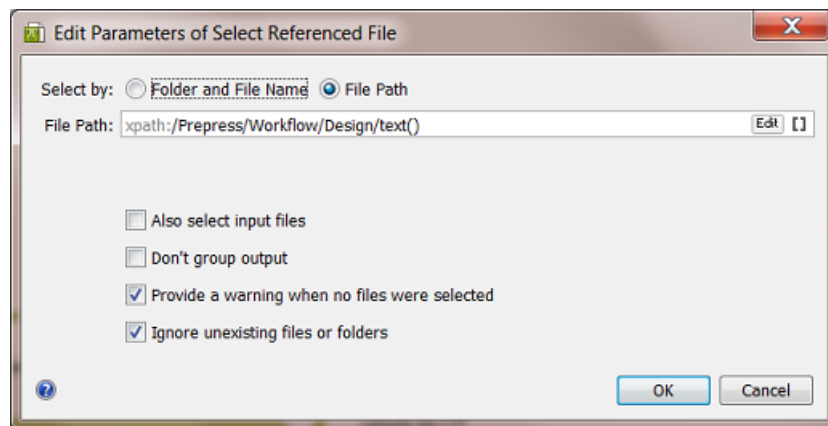

8. Click **OK** to confirm these settings.
9. Save your workflow.

### Step 5 - Pick up the Workflow Parameters in your Workflow

We refer to the chapter [Workflows](#) to learn more on making workflows or on the tasks and workflow controls used in this example. We will here focus on what is specific in our example workflow.

Our workflow does not use the **Job** concept and we (therefore) use **Workflow Parameters**:

- in the **3 Routers**

- in the **Preflight with PitStop** step
- in the **Create Report (ReportMaker)** step
- in the **Send E-mail** step
- in the **Upload via FTP** step.

**In the 3 Routers**

A value in the XML decides where the workflow will route to. Follow these steps for each **Router** (they are very similar in all 3 **routers**):

1. In the workflow, open the **Router**.
2. In **Route based on**, choose **SmartName value** from the list.
3. In **SmartName**, pick the appropriate one from the list, category **'Workflow Parameters'** ([WFP.]) and click **Insert**.

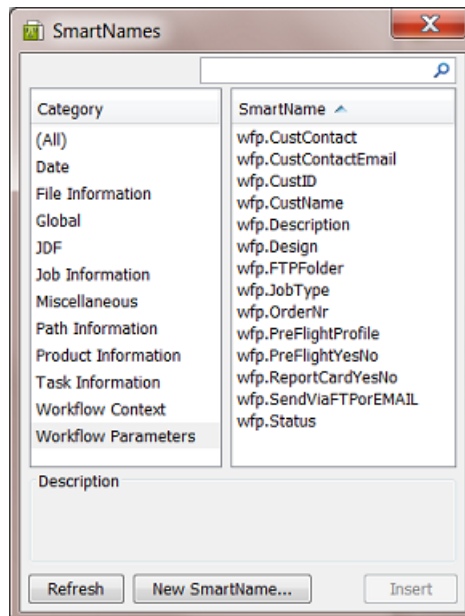

As can be seen in below screen shot, the 1st **Router** in the workflow needs the SmartName [wfp.PreFlightYesNo] . The 2nd **Router** needs [wfp.ReportCardYesNo] . The 3rd **Router** needs [wfp.SendViaFTPorEMAIL] .

4. Close the list of **SmartNames** by clicking on the **X**.
5. Now set the relation between the SmartName value and the route to follow. See this example for the 1st **Router** deciding if preflight should be done:

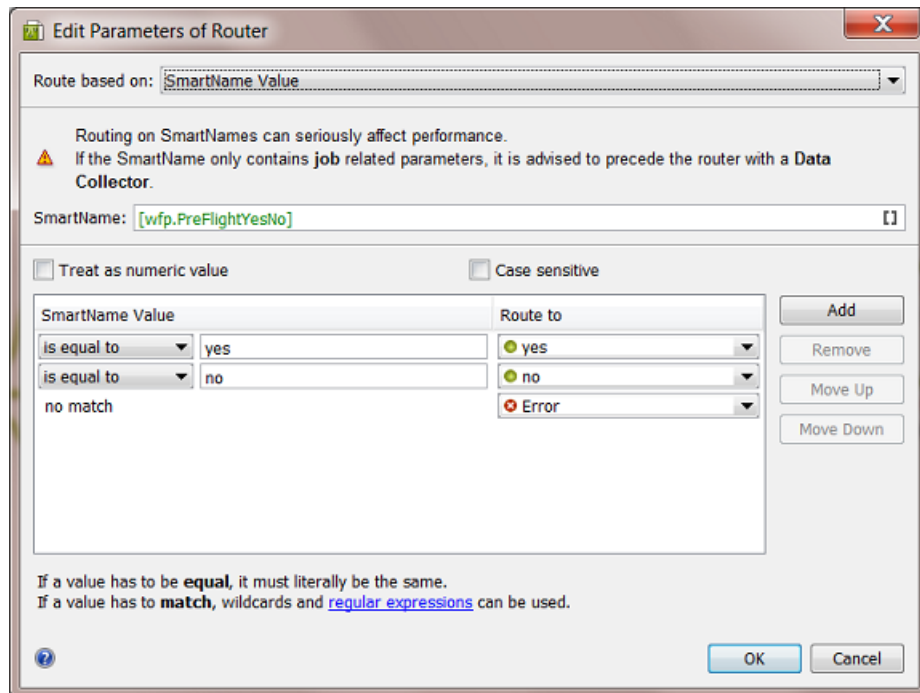

See this example for the 2nd **Router** deciding if a report card should be created:

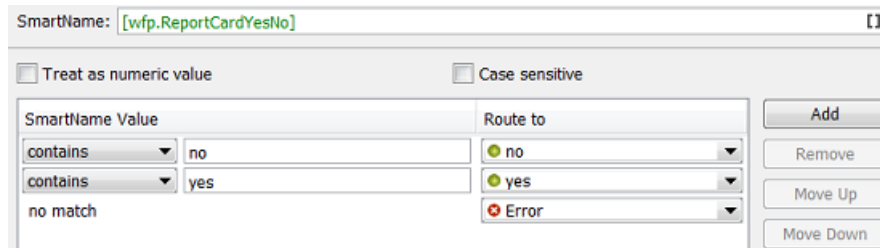

See this example for the 3rd **Router** deciding whether FTP or E-mail should be used:

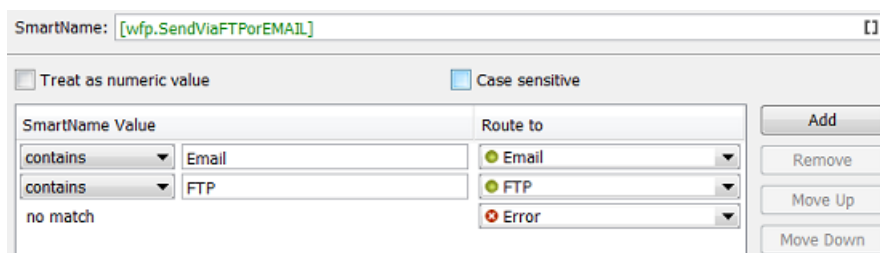

6. Click **OK** to confirm the Router settings and close the workflow step.
7. Save your workflow.

**In the Preflight step**

In our example, the XML file also decides which preflight profile needs to be used.



**Note:** See the full documentation of this workflow step in [Preflight with PitStop Task](#) on page 1149.

1. In the workflow, open the step **Preflight with PitStop**.
2. Define the Output folder and name. Mind that this is not for the preflight report file.
3. In the **Preflight** tab, in **Profile**, insert the **Workflow Parameter SmartName** for the profile as part of the path.

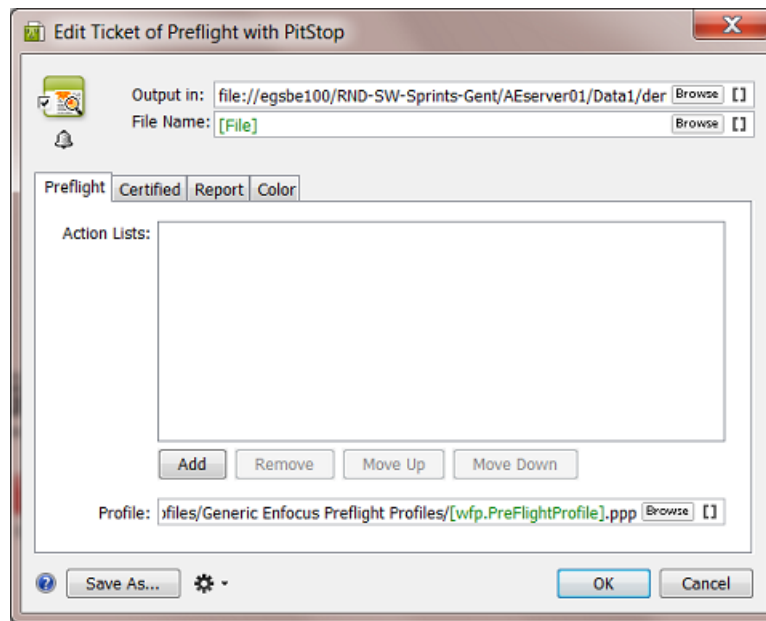

4. In the **Report** tab, define the output folder and name for the preflight report that you will send to the customer.

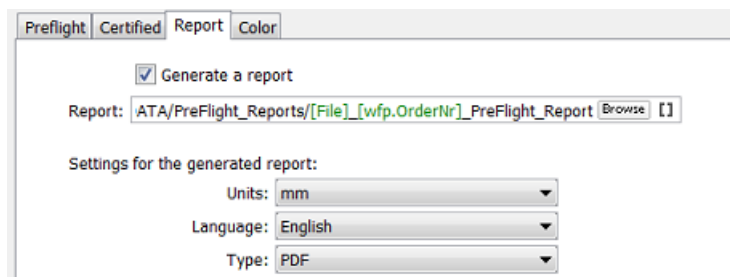

5. Set any other options as wished.
6. Click **OK** to confirm the settings and close this workflow step.
7. Now drag the logical connections between the steps. The pin that represents the output of the preflight report should link to the **Data Collector**. That file will be sent to the customer, the input design file will not be sent.



8. Save your workflow.

**In the Send E-mail step**

In our example, the XML file decides if the resulting files will be e-mailed or FTP'd to the customer.



**Note:** See the full documentation of this ticket in [Send E-mail](#) on page 448.

1. In the workflow, open the step **Send via E-mail**.
2. In **To**, add the **Workflow Parameter SmartName** for the E-mail of the customer contact for this job order.
3. In the **Subject** line, add the **Workflow Parameter SmartName** for the job order.
4. In **Message**, add the **Workflow Parameter SmartName** for the name of the customer contact.
5. Fill in extra fields as wished

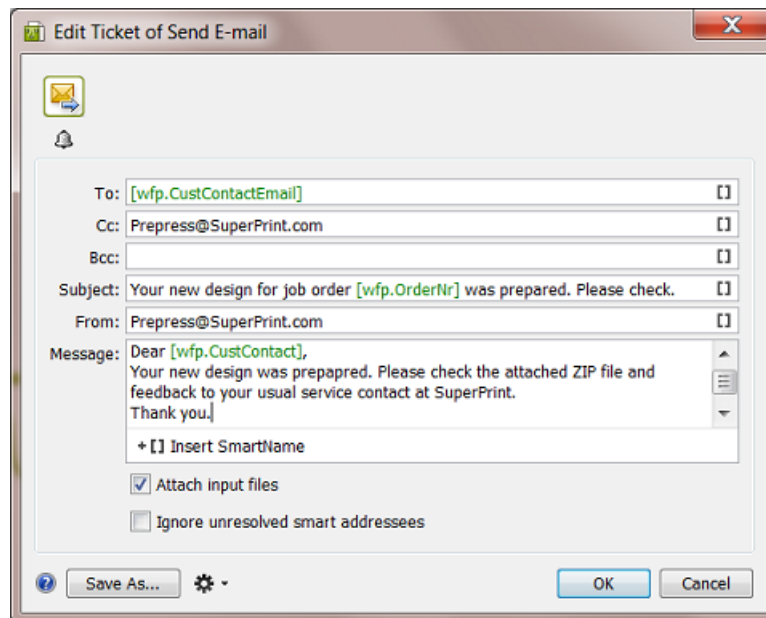

6. Click **OK** to confirm the settings and close this workflow step.
7. Save your workflow.

**In the Upload via FTP step**

In our example, the XML file decides if the resulting files will be e-mailed or FTP'd to the customer.



**Note:** See the full documentation of this ticket in [Task 'Upload via FTP'](#) on page 1806.

1. In the workflow, open the step **Upload via FTP**.
2. Enter the name of the **Host**.
3. In **Folder**, use the **Workflow Parameter SmartNames** to send the ZIP into a folder with a logical name. For example:

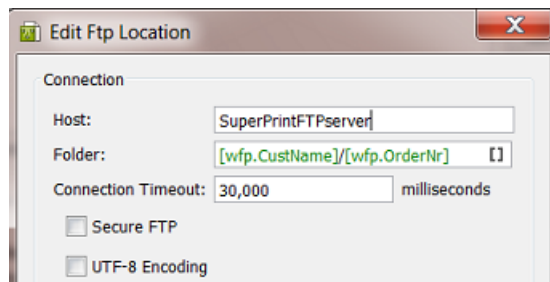

4. Set other settings as wished.
5. Click **OK** to confirm and close this dialog.
6. **TIP:** Optionally, you can send the customer contact an E-mail that his files are on the FTP server. Use the **Notification** tool of this workflow step to do this. Insert the **Workflow Parameter SmartName** for the E-mail and name, similar to how we did it in [the settings of the 'Send E-mail' step](#).
7. Click **OK** to confirm the settings and close this workflow step.
8. Save your workflow.

**Step 6 - Data structure of this Workflow**

This is a workflow that does not use the **Job** concept, so you can not store all your data in subfolders of a **Job Folder**.

The data structure that this example workflow creates looks like this:

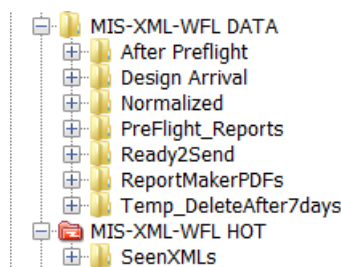

- The folder MIS-XML-WFL DATA contains all the data that this workflow creates. See the logical names of the (automatically) created subfolders. These folder names were set in the **'Output in'** fields of the relevant workflow steps.



- The folder MIS-XML-WFL HOT will be the folder used for the **Folder Access Point**.

**Step 7 - Test the Workflow**

1. In the **Pilot**, select your input XML file.
2. Then select the workflow you created and open it (double click).
3. **Launch and Monitor:** Press **CTRL-ALT-Enter** or Press **ALT** while clicking .
4. Drag the output file numbers so you can see these output files:

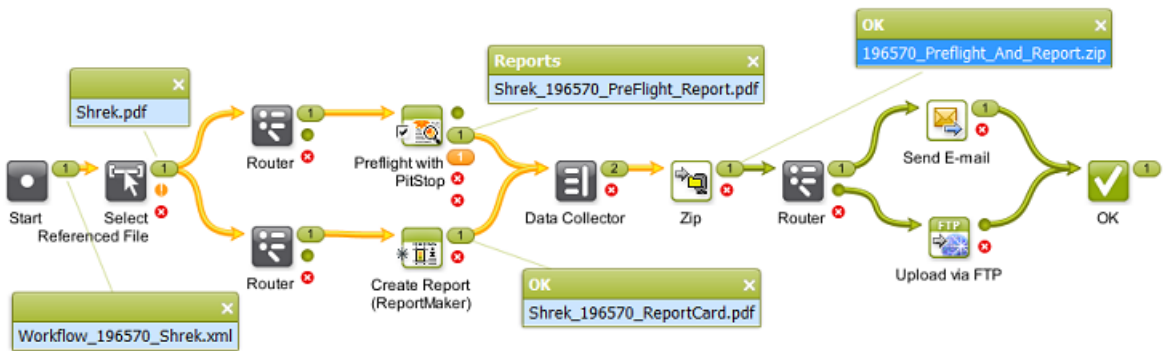

**Step 8 - Create the Folder Access Point and Test Again**



**Note:** If you are not familiar yet with **Access Points**, then first read [Access Points](#) on page 1777.

1. In the Pilot, go to the **Access Points** view.
2. Create a new **Access Point** and choose the type **Folder**.
3. Give it a logical **Name** and **Description**.
4. In **Folder Settings**, indicate the folder where the external system will write the XML files.

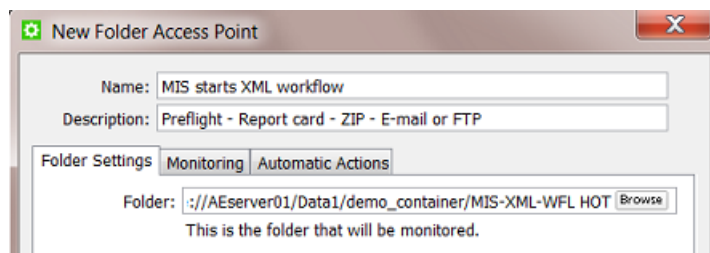

5. In **Monitoring**, set your preferred time interval.
6. In **Automatic Actions**, indicate the folder where the XML files should be moved to once they are processed.

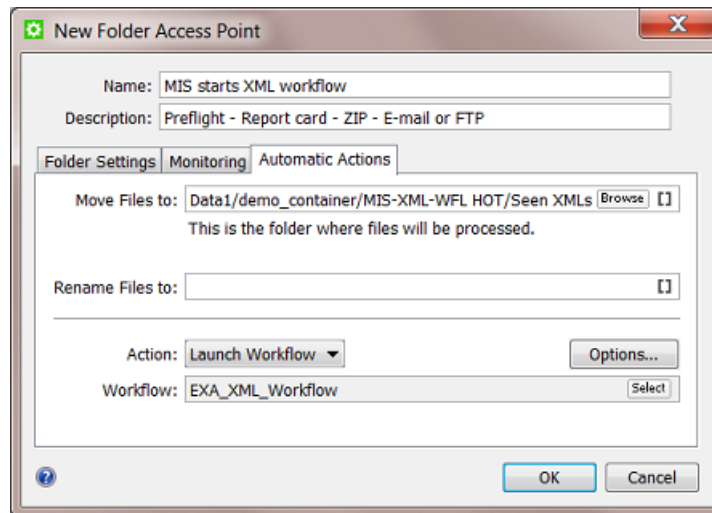

7. Set the **Action** to **Launch Workflow** and select the workflow of this example.
8. Click **OK** to confirm and close.
9. With the new **Access Point** selected, wait until the time interval passes or press '**Scan now**' to see the resulting tasks appear:

Access Points					
Name	Active	Description	Type	C...	Action
Get Jobs From MIS DB	No		Database		Launch Workflow (EXA_DB_AP_MyOrde...
MIS starts XML workflow	Yes	Preflight - Report card - ZIP - E-mail or FTP	Folder		Launch Workflow (EXA_XML_Workflow)

Tasks							
File Name	Jo...	Task Type	Progress	Phase	State	Launched	
Workflow_196570_Shrek_Processed.xml		Workflow	100%			8/7/14 2:06 PM	
Workflow_196570_Shrek_yes_yes_Processed.xml		Workflow	100%			8/7/14 2:01 PM	
Workflow_196570_Shrek_No_No_Processed.xml		Workflow	100%			8/7/14 2:01 PM	

The screen shot shows 2 extra tests where the Preflight ended with a warning.

10. Check the workflow in more detail (output files and folders, XMLs with different options).

### Step 9 - Possible Workflow Extensions

Here are some ideas to make this workflow even more powerful:

#### Feedback new status to MIS

It would be logic to inform the (business) system that sent you the XML on the fact that the workflow has finished. Here are some tips on how to do that:

- Adding a **Create XML** step to the workflow and send an XML with the status on a folder that that system will scan.
- Adding a **Interact with Database** step to the workflow and have a database query write that status right back into that system's database.



**Note:** We can not use **Milestones** here because we are not working in a **Job** context.

Learn more about such possibilities in [AE sending data Back to the External System](#) on page 1776

### Adding the Preflight Status already in the Email or Report File name

The customer might want to first check the designs where the Preflight showed an error or warning. To make this possible, you could extend the workflow to capture the Preflight status and use it as a SmartName. You could then insert that SmartName

- in the Email subject and or message
- in the FTP folder or name of the ZIP.

## 24.8.6. Getting info from a Web Service into a Workflow

### Summary

Your company has printing plants in site A and site B. Automation Engine is in headquarters ('site HQ') where also the business system is. To enable a cheaper and faster delivery, your planning system asks Automation Engine which printing plant is closest to the customer, where the printed product should be shipped to ('site C').

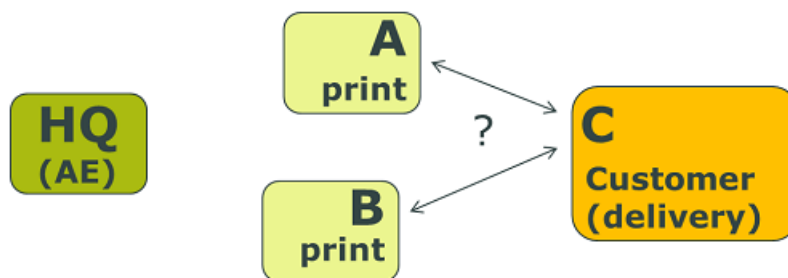

Automation Engine asks the web service of GoogleMaps the distances and reports the result back to the planning system. The planning system sends its request to Automation Engine via an XML file. Automation Engine will also send a result back as an XML file.

Tools used in this example:

- **SmartNames** using **Xpath Builder**
- **Workflow Parameters**
- **Interact with Web Service** task
- **Map Data** task
- The **Data Collector** and **Sort** workflow control

### Step 1 - Analyse the Input XML



**Tip:** Click [this link](#) to download a ZIP with the sample XML file used in this example.

In our example, this is the XML file that we get from the planning system (RouteCalcRequest.xml):

```
<?xml version="1.0"?>
- <RouteCalc>
  <OrderNr>234567</OrderNr>
  <CustomerID>6666</CustomerID>
  <CustomerName>Graceland</CustomerName>
  - <Delivery_Address>
    <Delivery_StreetAndNr>706 Union Avenue </Delivery_StreetAndNr>
    <Delivery_ZIP>TN 38103</Delivery_ZIP>
    <Delivery_City>Memphis</Delivery_City>
    <Delivery_StateCountry>USA</Delivery_StateCountry>
  </Delivery_Address>
  - <PrintSiteA_Address>
    <SiteA_StreetAndNr>2804 Opryland Drive</SiteA_StreetAndNr>
    <SiteA_ZIP>TN 37214</SiteA_ZIP>
    <SiteA_City>Nashville</SiteA_City>
    <SiteA_StateCountry>USA</SiteA_StateCountry>
  </PrintSiteA_Address>
  - <PrintSiteB_Address>
    <SiteB_StreetAndNr>726 Saint Peter Street</SiteB_StreetAndNr>
    <SiteB_ZIP>LA 70116</SiteB_ZIP>
    <SiteB_City>New Orleans</SiteB_City>
    <SiteB_StateCountry>USA</SiteB_StateCountry>
  </PrintSiteB_Address>
</RouteCalc>
```

For job-order 234567, the planning system asks which printing site is closest to the delivery site in Memphis: A (Nashville) or B (New Orleans).



**Note:** This example contains address as they are written in the USA.

### Step 2 - Configure the Web Service

As documented in [Task 'Interact with Web Service'](#) on page 1846, the GoogleMaps API needs to be added in **Configure > External Web Services**.

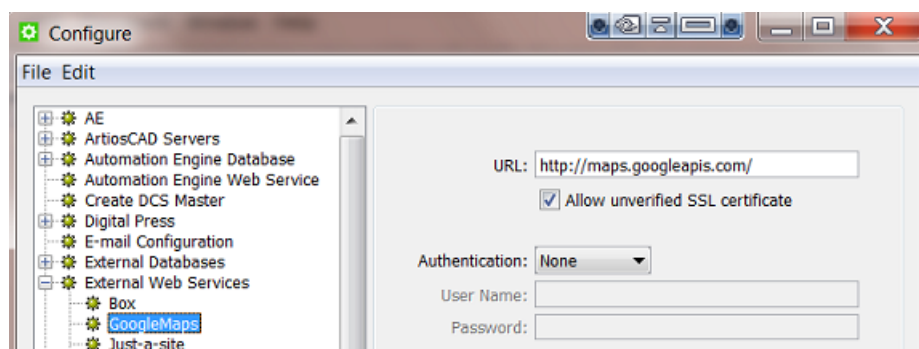

### Step 3 - Create the workflow

Create a workflow with these steps. We will define some details later.

1. In Pilot, select the input XML file and create a workflow with these steps (the 2 'GoogleMaps' steps are **Interact with Web Service** steps.)



See how the workflow will use a **Map Data** step to join and partially redefine the outputs from the 2 interactions with *GoogleMaps*. Alternatively, you could make this workflow by using a **Map Data** step after each interaction with *GoogleMaps* step, and then later end it with a **Join XML** step.

2. Edit the names of the 2 **Interact with Web Service** steps to those as in the screen shot.
3. Save your workflow with a logical name. For example "EXA - WEB - RouteCalc".

### Step 4 - Load Workflow Parameters from the XML

This example does not use the **Job** concept so we will create **Workflow Parameters** and pick those up throughout the workflow.

1. Open the workflow you created and in the menu go to **Advanced > Manage Workflow Parameters**.
2. Check **Use values from XML file** and enter this combination of **SmartNames**: [URL of Folder of Input]/[File].xml (see also in below screen shot).
3. Click on **Load Workflow Parameters from XML...** (below right). Browse to your XML example file and click **Open**. Choose to **Leave blank to select all elements below the root element**. All the XML element names will be listed, with their value from in this specific example XML:

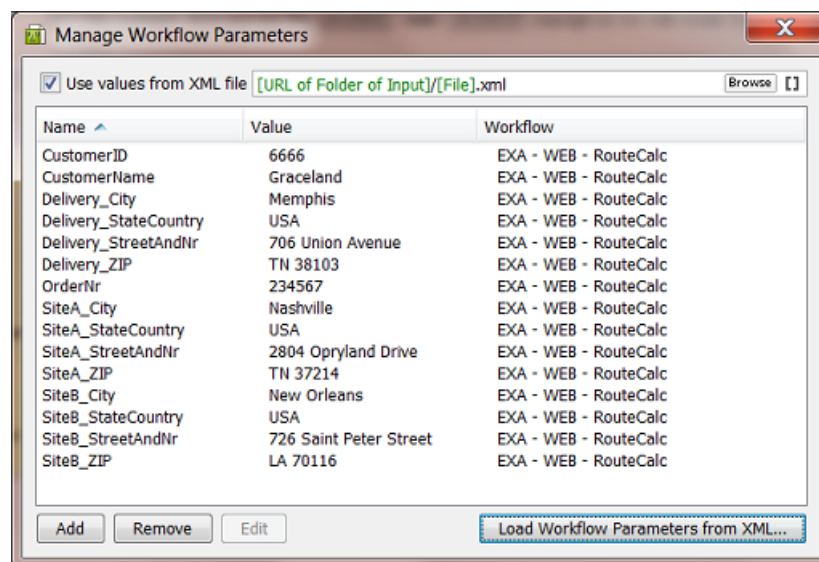

4. Click on **X** to close this dialog. These parameters are now **Workflow Parameters**. Every time this workflow is launched, they will be "loaded" before even starting the first workflow step.
5. Save your workflow.

### Step 5 - Define the 2 Interact with Web Service steps

The settings for these 2 steps are almost identical. We will explain the ones for step 'A' and at the end show the differences with those for 'B'.

1. Double-click the step 'GoogleMaps A' to open it.
2. Set logical values for the **Output in** and **File Name** fields.

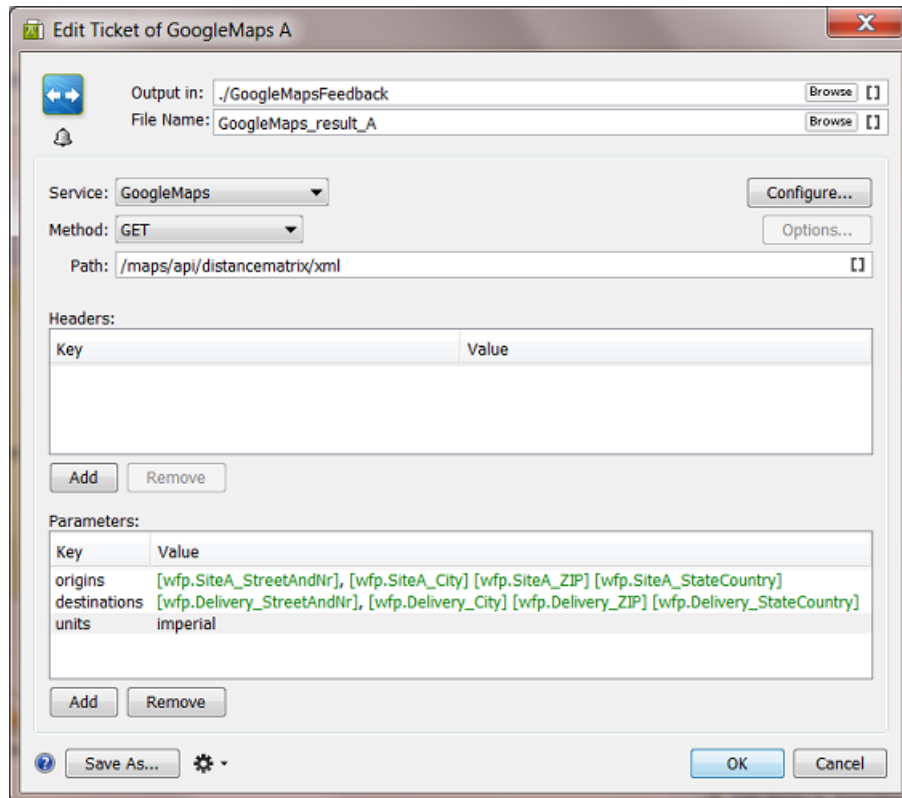

3. Choose the web **Service** you configured for Google Maps and choose the **Method GET**.
4. Enter the **Path** as defined in the API documentation of Google Maps.  
Because we are only interested in the distances, we here use Google Map's API 'distancematrix' and not the API 'directions'.
5. In **Parameters**, use **Workflow parameters** to define the API's key **origins** and **destinations**.  
Unlike in Google Map's API 'directions', the keys 'origin' and 'destination' are both in plural here! The comma or space between the parts of the address needs to lead to a valid address specification for Google Maps.
6. The key **units** is optional. The default already is 'imperial'(miles, feet, inches ..)
7. Press **OK** to confirm and close this dialog.
8. Now double-click the other step 'GoogleMaps B' to open it.
9. Make sure the **File name** of the output XML file is different! And for the key **origins**, use the **Workflow parameters** that match the printing site 'B':

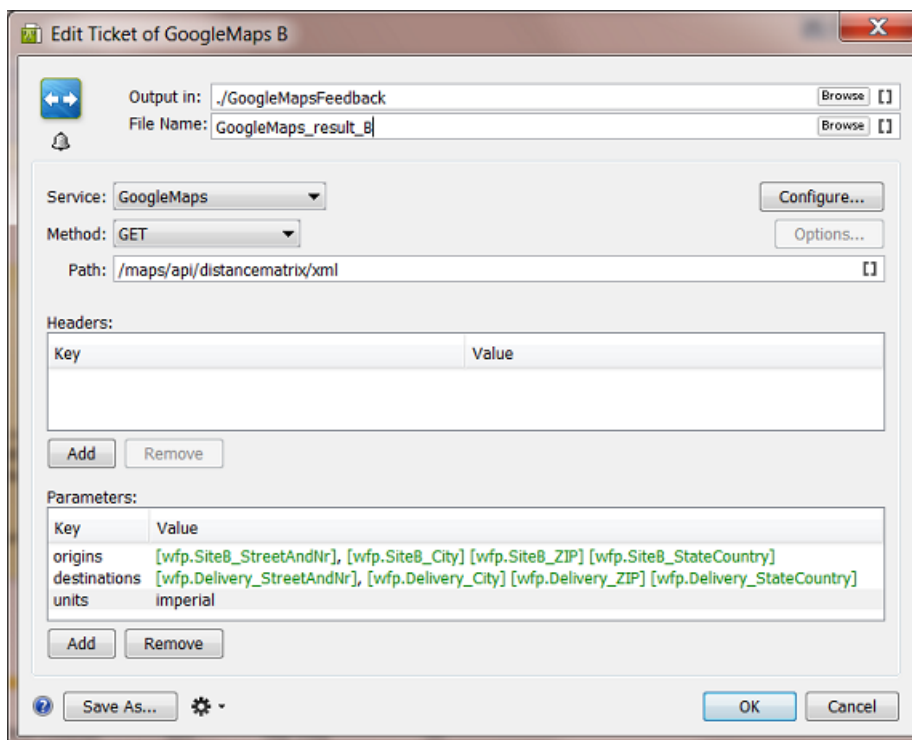

10. Press **OK** to confirm and close this dialog.

11. Save your workflow.

### Step 6 - Settings to Collect and Sort the 2 Responses

It is important in this workflow to keep control over the order of the 2 XML files that Google Maps will return us. You do not want to risk mixing up the distances for site A or B.

#### Settings for the Data Collector step:

Keep the default settings: **Group all collected data**

#### Settings for the Sort step:

Keep the default settings: **Sort by file name in ascending order**

Save your workflow.

### Step 7 - First test to get the Google Maps result files

To define the settings for the **Map Data** step, we need the result XML files from the interactions with Google Maps.

1. In **Pilot**, select the input XML file `RouteCalcRequest.xml` and launch your workflow `EXA - WEB - RouteCalc`. It will probably fail, because we haven't defined the **Map Data** step yet.
2. You should get these 2 files:

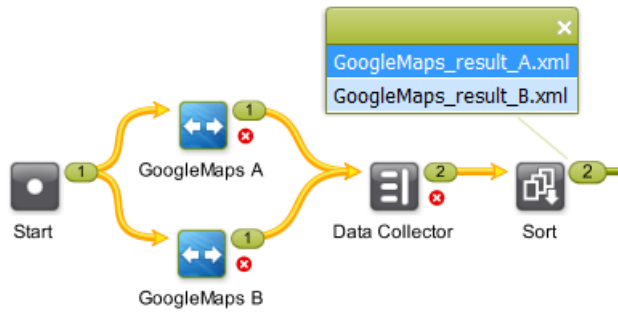

Right-click and choose 'Open' to inspect them.

This is what Google Maps returns us when we ask the distance between site **A** and the delivery site:

```
<?xml version="1.0" encoding="UTF-8" ?>
- <DistanceMatrixResponse>
  <status>OK</status>
  <origin_address>2804 Opryland Drive, Nashville, TN 37214, USA</origin_address>
  <destination_address>706 Union Avenue, Memphis, TN 38103, USA</destination_address>
  - <row>
    - <element>
      <status>OK</status>
      - <duration>
        <value>11860</value>
        <text>3 hours 18 mins</text>
      </duration>
      - <distance>
        <value>358003</value>
        <text>222 mi</text>
      </distance>
    </element>
  </row>
</DistanceMatrixResponse>
```

And this is what Google Maps returns us when asking the distance between site **B** and the delivery site:

```
<?xml version="1.0" encoding="UTF-8" ?>
- <DistanceMatrixResponse>
  <status>OK</status>
  <origin_address>726 Saint Peter Street, New Orleans, LA 70116, USA</origin_address>
  <destination_address>706 Union Avenue, Memphis, TN 38103, USA</destination_address>
  - <row>
    - <element>
      <status>OK</status>
      - <duration>
        <value>20309</value>
        <text>5 hours 38 mins</text>
      </duration>
      - <distance>
        <value>634574</value>
        <text>394 mi</text>
      </distance>
    </element>
  </row>
</DistanceMatrixResponse>
```





**Note:** In Google Maps API, the default value unit for time is seconds and the default value unit for distance is meters.

### Step 8 - Settings in the Map Data step

Next thing to do in this workflow is merge this information into one XML file.

1. In your workflow (**edit mode!**), open the **Map Data** step.  
You will see that it proposes the workflow's input file (`RouteCalcRequest.xml`) as example input file. This is **not** what we want here!
2. Select the line with that default example **Input File** and double-click to open it. Browse to the first input file we really want as example: `GoogleMaps_result_A.xml`, which we wrote in a subfolder `GoogleMapsFeedback`. Click **OK** to confirm.
3. Click **Add** and browse to the 2nd file we got back from Google Maps and add it as 2nd example **Input File**. Click **OK** to confirm.
4. This also a good time to set a logical folder and file name for this output XML file that we will feed back to the planning system. Let's assume that our output folder is a hot folder of that planning system. Use the **Workflow Parameter** `[wfp.OrderNr]` in the file name.

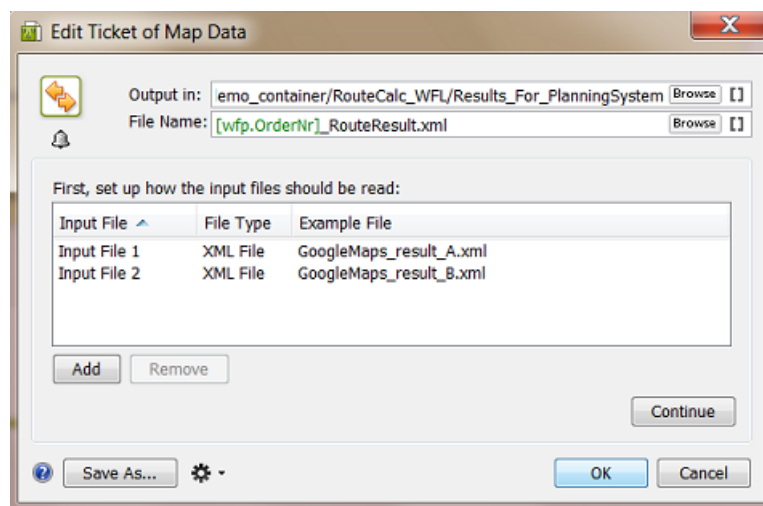

5. Click **Continue** to start defining the XML content that we want to send back.
6. We will first pick up some parameters from the example input files. On the right, in **Parameters**, click **Add**.
7. Click **Edit** to open the **Xpath Builder** and highlight the value of the `<text>` version of the element `<distance>` (222 mi).

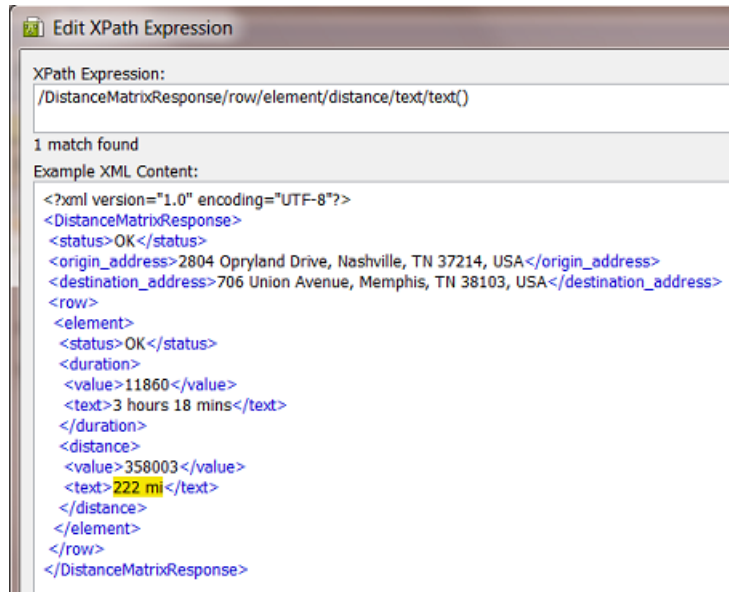

8. Click **OK** to close. In the **Add Parameter** dialog, enter the name 'Distance\_From\_A' and click **OK** to close.
9. Do the same for the value of the <text> version of the element <duration> (3 hours 18 mins).
10. Then create the same 2 parameters but using the other example input file 'GoogleMaps\_result\_B.xml' ('394 mi' and '5 hours 38 mins'). You end up with these 4:

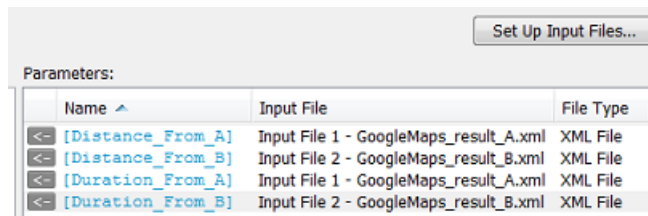

11. Now specify the output XML as shown in below screen shot. See how we use a mix of **Workflow Parameters** and **Parameters** from the example **Input Files**.

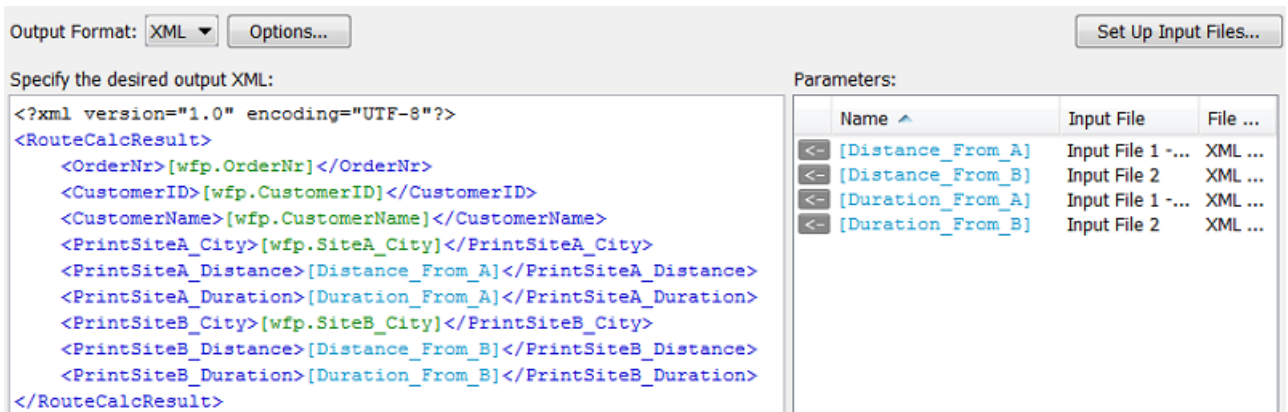

12. Click **OK** to close this workflow step.
13. Save your workflow.

### Step 9 - Test the complete workflow

Our workflow is now complete (we assume that the place where the **Map Data** step writes the output XML is monitored by the planning system).

1. In **Pilot**, select the input XML file `RouteCalcRequest.xml` and launch your workflow 'EXA - WEB - RouteCalc'.
2. Check the flow and names of the output files. It should look like this:

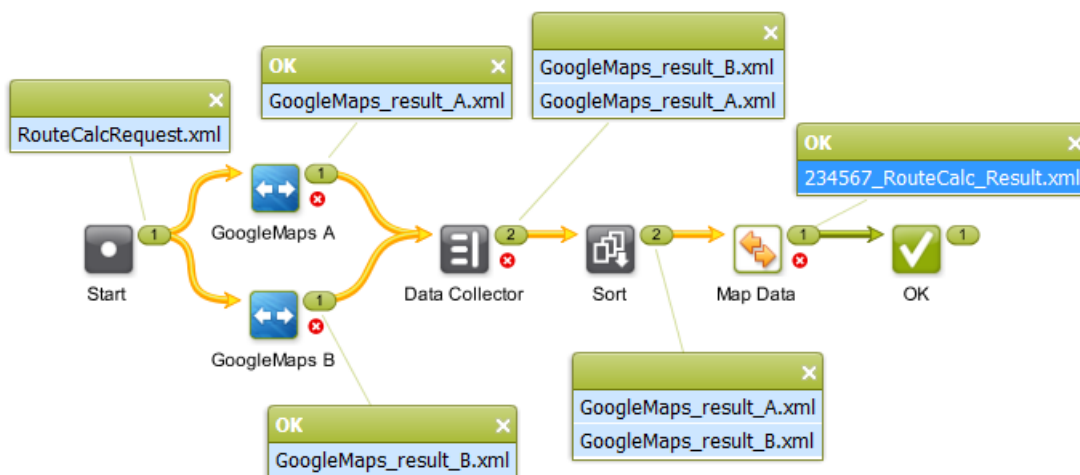

3. Right-click and open the final output file '234567\_RouteCalc\_Result.xml'. It should look like this:

```
<?xml version="1.0" encoding="UTF-8" ?>
- <RouteCalcResult>
  <OrderNr>234567</OrderNr>
  <CustomerID>6666</CustomerID>
  <CustomerName>Graceland</CustomerName>
  <Delivery_City>Memphis</Delivery_City>
  <PrintSiteA_City>Nashville</PrintSiteA_City>
  <PrintSiteA_Distance>222 mi</PrintSiteA_Distance>
  <PrintSiteA_Duration>3 hours 18 mins</PrintSiteA_Duration>
  <PrintSiteB_City>New Orleans</PrintSiteB_City>
  <PrintSiteB_Distance>394 mi</PrintSiteB_Distance>
  <PrintSiteB_Duration>5 hours 38 mins</PrintSiteB_Duration>
</RouteCalcResult>
```

The planning system will conclude that, for this job order, the printing site in Nashville is closest.

## 24.8.7. Updating a Product Status in an External System via Interact with Database

### Summary

Our workflow includes changing the status of a **Product Part** to **Waiting for Approval**. Because this information is important for the service and sales staff, we will also inform the business system of this new status.



**Note:** In this example, we assume you are familiar with the **Products** tool. Learn more in the dedicated chapter [Products](#) on page 594.

Tools used in this example:

- **Products** tool
- **Manage Product Status** task
- **Interact with Database** task, to an external MS SQL Server
- **Mark File** and **Select Marked File** task
- **ReportMaker** task
- **Send E-mail** task

### Step 1 - Analysis and Setup of the External Database



**Tip:** Click [this link](#) to download a ZIP with the sample database file used in this example.

#### Structure of the External Database Table

This is the database we will interact with:

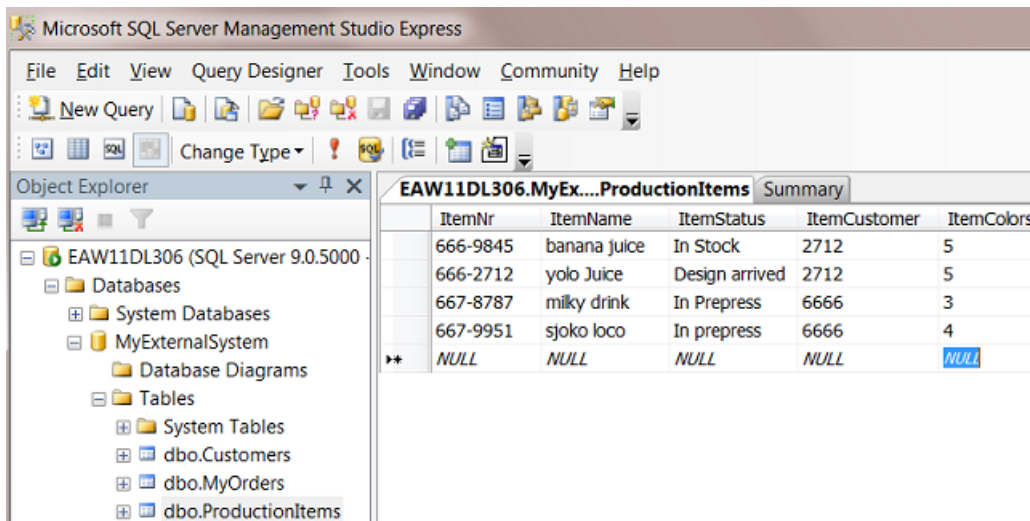

- The database software type is a MS SQL server.
- It runs on a server computer named EAW11DL306.
- The name of the database that we will access is MyExternalSystem.
- The name of the (opened) table is ProductionItems.
- The table contains the description of 4 production items.

- The item 'yolo juice' shows its 'ItemStatus' on 'Design arrived'. That is the database record that we will change in this example.

### Configuring the Link to this External Database

Setting up the link to this **External Database** is identical to how we did it for a previous example in [Step 2 - Configure the Link to the External Database](#) on page 1882.

### Step 2 - Initial Product Status and Job Setup

This is the starting configuration we need on Automation Engine:

- In **Pilot > Products > Manage Product Statuses**, create a **Status 'Design arrived'** with a blue color and create a status **'Waiting For Approval'** with a yellow color.
- Create a **Product** 666-2712. Give it the status 'Design arrived' and link it to the **Job** 1237.

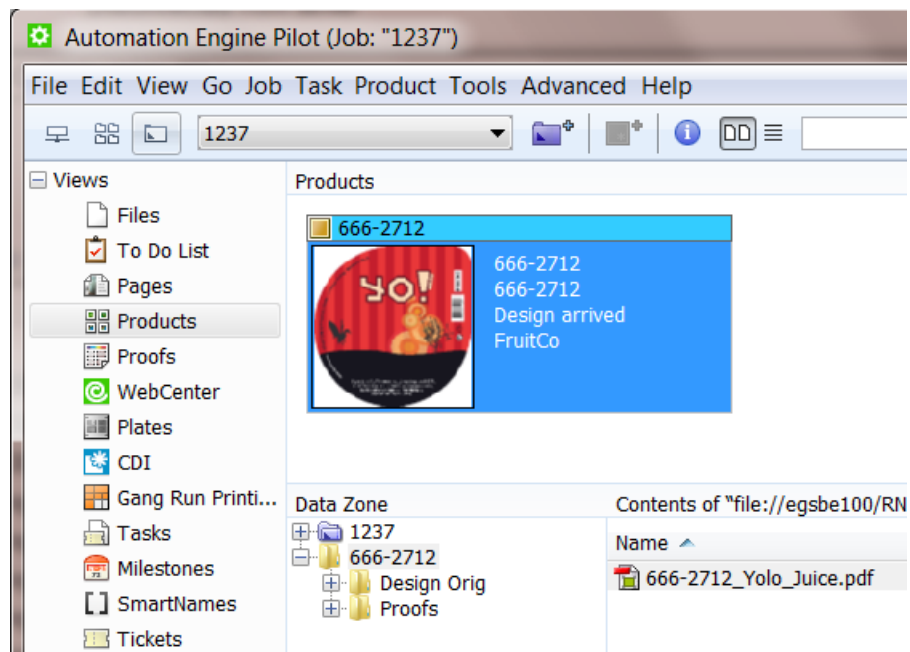

- The **Job** 1237 is for customer FruitCo.

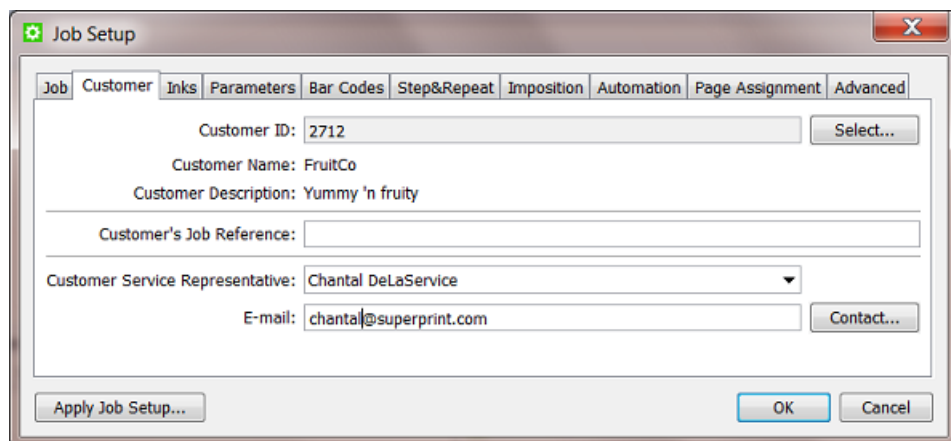

### Step 3 - Create the Workflow

In our example, we assume that the design was already preflighted and made ready for print. Our workflow starts by creating a proof report and e-mailing it to the customer. It then changes the **Product** status to **Waiting For Approval** and also updates the external database of this new status.

1. Create this workflow and save it as 'EXA - PRODSTAT' :



2. In the **Mark File** step, set the **tag** 'Product file'.

3. In the **Create Report** step, we advise these logical settings:

- choose any **Report Template**
- choose to **Export** to an extra PDF (we will e-mail the report PDF so you do not want the PDF to refer to external files!)
- choose a to **Output** the file somewhere in the **Job Folder** (because the report will probably contain Job specific info)
- choose a logical **File Name** which will make sense to the customer when he receives it via e-mail.

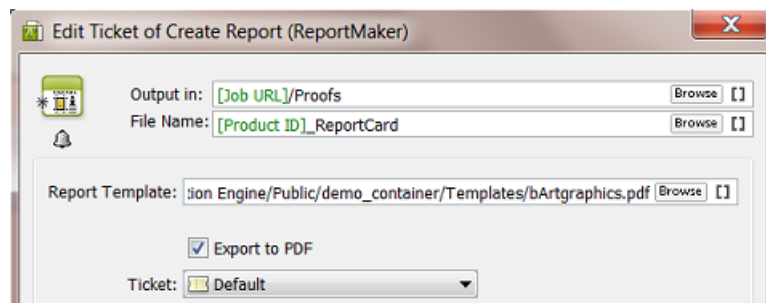

4. In the **Send E-mail** step, we advise these logical settings:

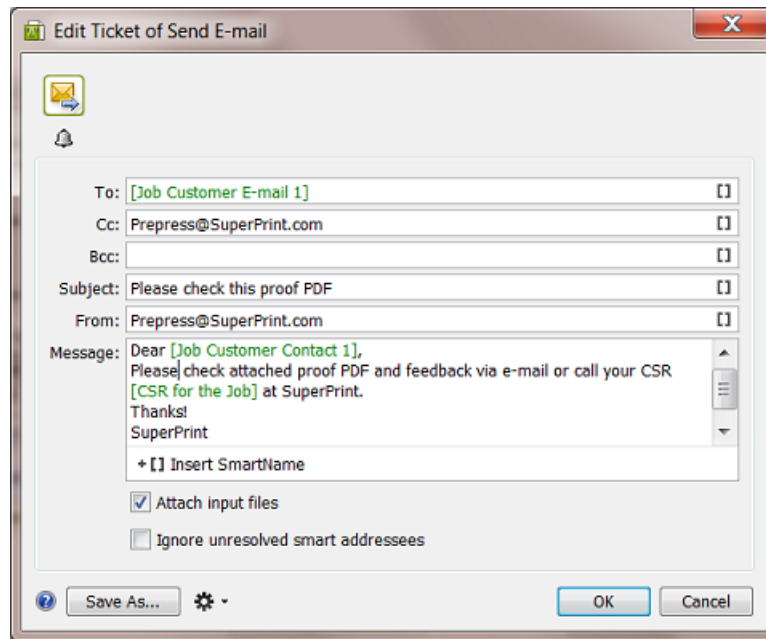

- 5. In the **Select Mark File** step, use 'Product file' as the tag to be selected.
- 6. In the **Manage Product Status** step, select the **Status 'Waiting For Approval'**.

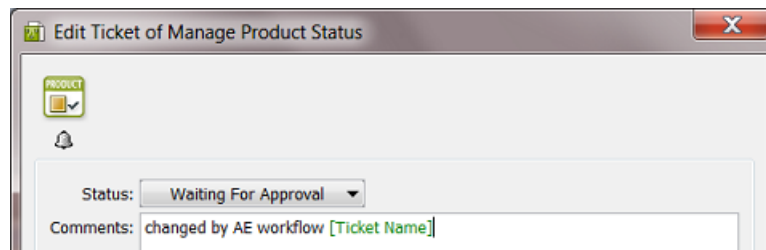

- 7. Save your workflow.

The **Interact with Database** step is described in the next step of this example.

#### Step 4 - Setup of the Interact with Database Step

These are settings we need:

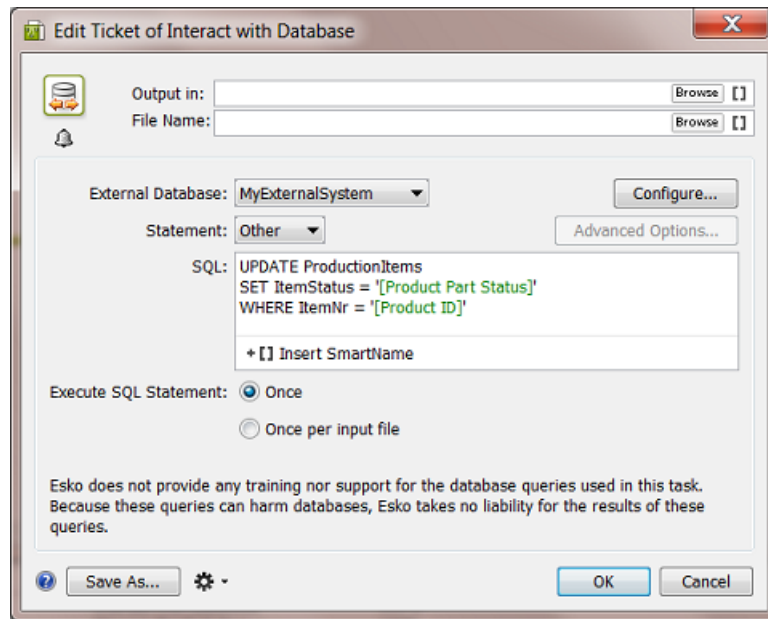

- **Output in** and **File Name**: because we are changing an existing database record, the type of **SQL** statement in this example is 'UPDATE'. As mentioned in [the documentation of this task](#), this task only outputs an XML file for 'SELECT' statements.
- **External Database**: select the one you set up for the database in this example.
- **Statement**: use **Other**.
- **SQL**: use the query as shown in the screen shot. The 2 **SmartNames** make this query work for all **Product (Parts)**.
- Click **OK** to close.
- Save your workflow.

**Step 5 - Test the Workflow**

1. In **Pilot**, open the **Job** '1237'.
2. In **Products View**, select the linked in **Product** '666-2712'.
3. Launch the workflow 'EXA - PRODSTAT' that you created (using a **Favorite** or right-click **Launch with** or...).



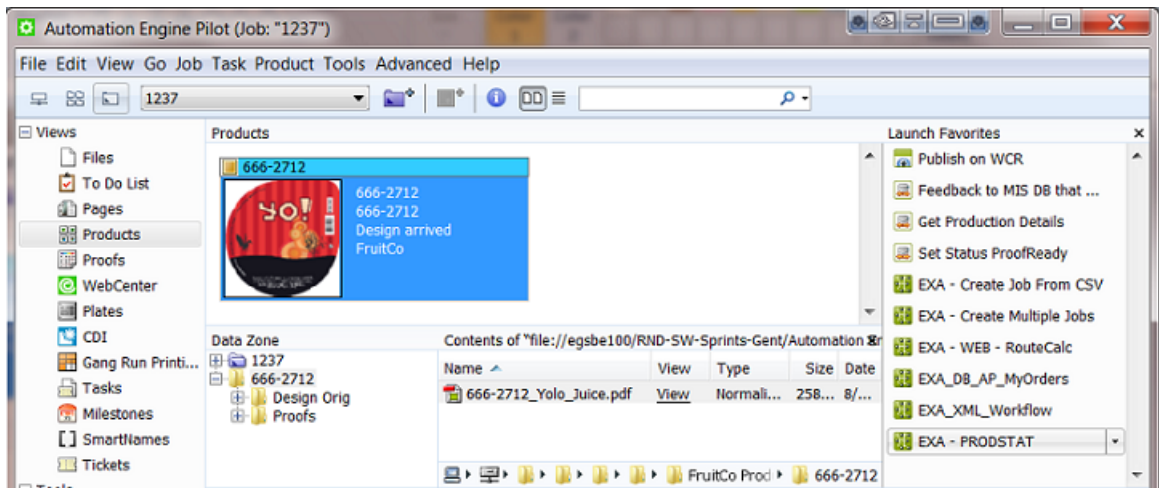

4. This is the result in the Pilot ; notice the Product's change in status and color:

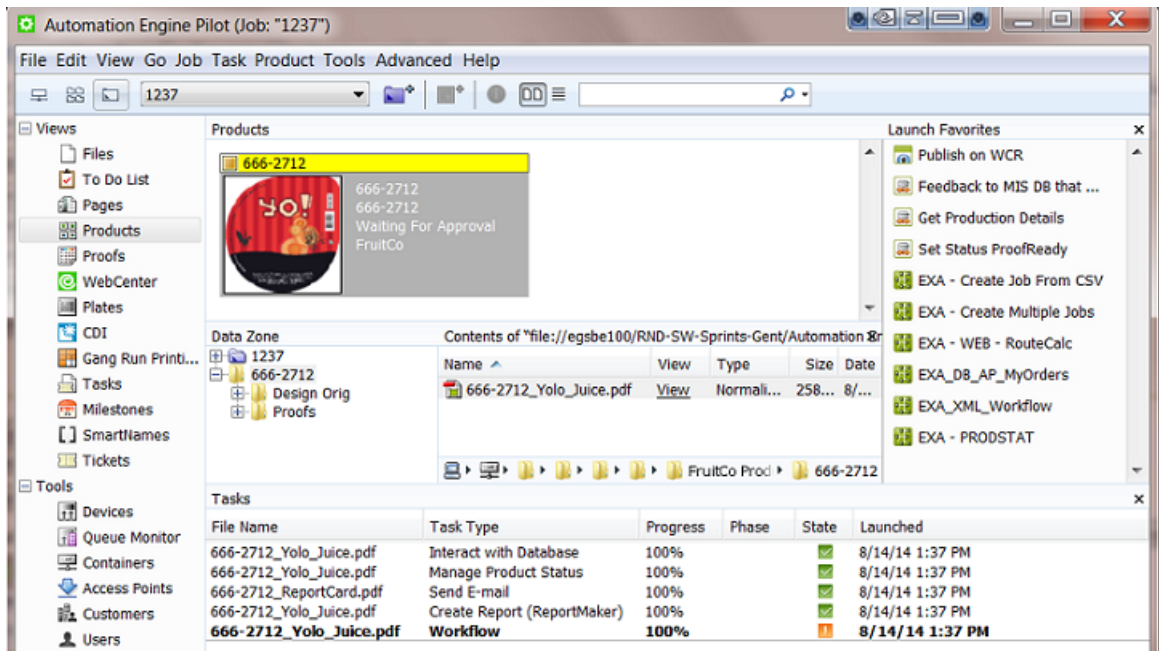

5. This is the resulting finished workflow:

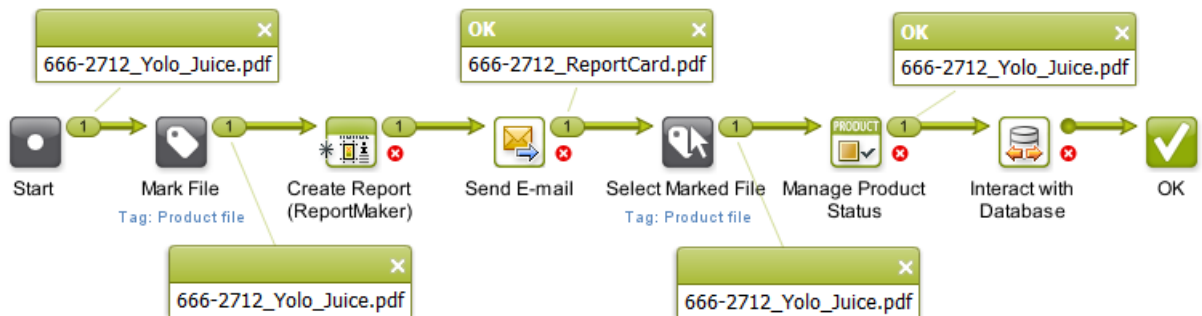

6. This is how the external database should have changed ; notice the new status 'Waiting For Approval' for item '666-2712':

EAW11DL306.MyEx....ProductionItems				Summary	
ItemNr	ItemName	ItemStatus	ItemCusto...	ItemColors	
666-9845	banana juice	In Stock	2712	5	
666-2712	yolo Juice	Waiting For Approval	2712	5	
667-8787	milky drink	In Prepress	6666	3	
667-9951	sjoko loco	In prepress	6666	4	

# 25. Using Scripts

---

## 25.1. Scripting Concept

---

### Automating Desktop and Other Applications

Although Automation Engine already offers a wide set of tools to create custom workflows, it is still possible that you miss some functionality or maybe to support less standard graphics format that you still use or receive.

This is why Automation Engine also offers custom scripting: you can write scripts (small programs) that typically represent actions that operators do interactively in their graphic desktop applications..

Once you created that script, the [Run Script task](#) enables to insert that task into your normal workflows. This is also how you can automate your desktop applications.

Some examples:

- To automate actions in desktop applications like Adobe Illustrator, Photoshop, InDesign (Server), etc. (via ExtendScript on macOS and Windows).
- To convert files into a format that Automation Engine tasks support. For example converting non-PDF compatible AI files into PDFs.



**Attention:** It is up to the user to verify that his intended use of the offered automation functionality is compliant with any third party license agreement and/or other restrictions applicable to any non-Esko products.

### Supported Script Types

- **AppleScript** (macOS), a scripting language created by Apple that facilitates automated control over script-able Mac applications.
- **ShellScript** (macOS), the shell scripting supported by the Mac Terminal.
- **Batch files** (Windows), a Windows script file that consists of a series of commands to be executed by the command-line interpreter.
- **Windows Script** (Windows), a Microsoft VBScript or JScript.
- **ExtendScript** (macOS and Windows), a type of JavaScript enriched with Adobe extensions that can be executed by certain Adobe applications.



**Attention:** When scripting Adobe applications, the Script Runner tool on Windows no longer supports 32 bit versions of those applications.

- **PowerShell** (macOS and Windows), a cross-platform task automation solution made up of a command-line shell, a scripting language, and a configuration management framework.



**Attention:** When installing PowerShell 7.x on Windows, make sure the option '**Add PowerShell to Path Environment Variable**' is checked.



**Tip:** Using native PowerShell scripts makes it easier to capture an error status of your script than when you run them via a Windows Batch file (a script error will end up on the error output pin of the script task).

### The Script Runner Tool

Executing such scripts starts in the [Run Script task](#). One of the settings in that task is to choose if the script will be executed by a separate **Script Runner** tool (that you installed earlier on a Mac or Windows client computer), or if the script can run on the Automation Engine server itself (in the 'on-board Script Runner').

When, for example, your script is a Windows batch file, it will be possible to run it on the Automation Engine server itself. But when the script needs to interact with a Mac (Adobe) application, it will require help from a standalone Script Runner that you also installed on that Mac.

Learn more in [The Script Runner Tool](#) on page 1918.

### Extra Information and Tips available as KB articles

Because the area of scripting is often about customization, the examples in this documentation do not cover all use cases.

We therefore advise to also check [Esko's Knowledge Base](#) for articles on this topic.

## 25.2. The Script Runner Tool

---

The Automation Engine server itself does not actually run your custom script: the AE task communicates with a tool called **Automation Engine Script Runner**.



**Attention:** As mentioned in [Scripting Concept](#), the '[Run Script](#)' task can run the script on the AE server itself (a Windows Script or batch file) or it could use a standalone Script Runner tool on a Mac or Windows client.

Here's an overview of the workflow when a standalone AE Script Runner is used:

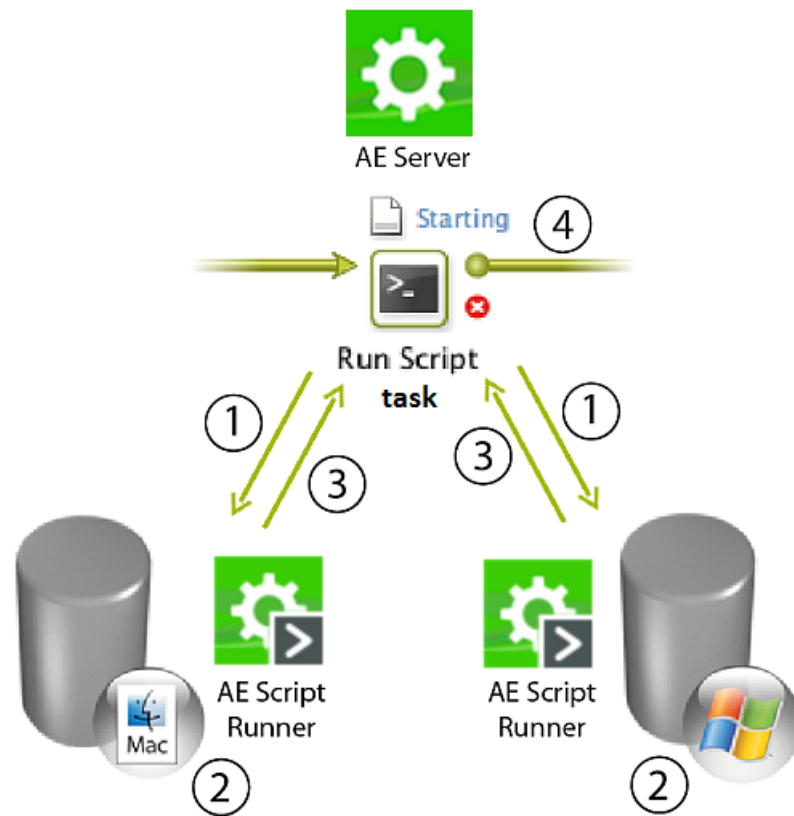

1. The **Run Script** task sends a request to run the selected script on its input file(s). The task can communicate optional script parameters and also defines the output folder for the resulting file(s).
2. The selected **Script Runner** processes the request and runs the script.
3. The **Script Runner** sends the results back to the Run Script task.
4. The workflow continues with the outputs from this Run Script task.

## 25.3. Installing Script Runner



**Important:** As mentioned in [the chapter on SaaS](#), installing and using external Script Runner tools is not supported when your AE is a SaaS setup.

Follow these steps to install the Script Runner tool.

These client applications and other tools can be downloaded:

1. Like the main client applications, also the Script Runner tool can be installed from an AE browser client. Go to `http://<AEserverName>:9000/#/downloads` ). In its home page, go to the tab **Apps & Tools > Tools** and **Download** Script Runner.
2. After downloading, double-click the 'dmg' file (Mac) or the 'exe' file (Windows) to start the installation. Follow the instructions in the Assistant (Mac) or Installshield Wizard (Windows).
3. Check the tool's preferences to make sure it is running on that computer:
  - On Windows, open **Start > All Programs > Esko > Automation Engine Script Runner > Preferences**.

- On macOS, open **Applications > Automation Engine Script Runner > Esko > Automation Engine Script Runner > Script Runner Preferences**.

In the **Script Runner Preferences** dialog, you can:

- **Start / Stop** the Script Runner (or just check if it is running).



**Note:** On Windows, this will run the Script Runner as a 'Service'. Learn about (the need for) other methods in [Adobe Applications on Windows: Run Script Runner as an Application \(Not as a Service\)](#) on page 1945.

- Enable / disable **Start at login**
- View / change the **Port** that the Script Runner is communicating with
- View / change the default folders for (types of) scripts.

Example (on Windows):

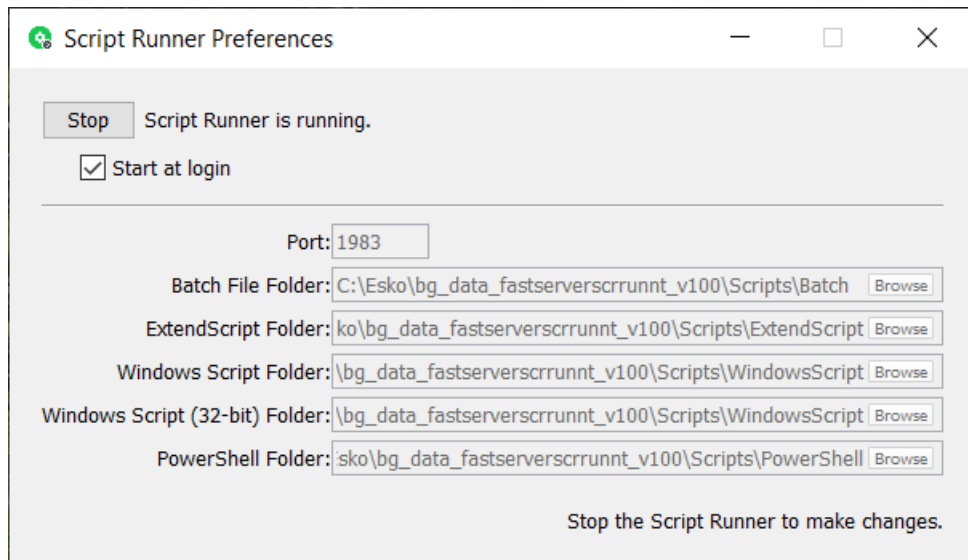

**Attention:** The above shown folders are local, on the Script Runner computer. Learn how you can (also) store them centrally in [Configuring Script Runner](#) on page 1920.

## 25.4. Configuring Script Runner

The Automation Engine server needs to know where you installed your **Script Runner(s)**. You could for example have 2 Macs dedicated to run scripts and also have the Automation Engine server itself have some Windows scripts or batch files running.

1. Install **Script Runner** on the client computers that will run scripts. Learn more in [Installing Script Runner](#) on page 1919.
2. In a **Pilot**, go to **Tools > Configure**.

3. Go to the category **Scripts**. (As mentioned earlier, this configuration topic does not appear in a SaaS setup)
4. Now define which computers will run the scripts. Press **Insert** or choose **File > New** to add one.

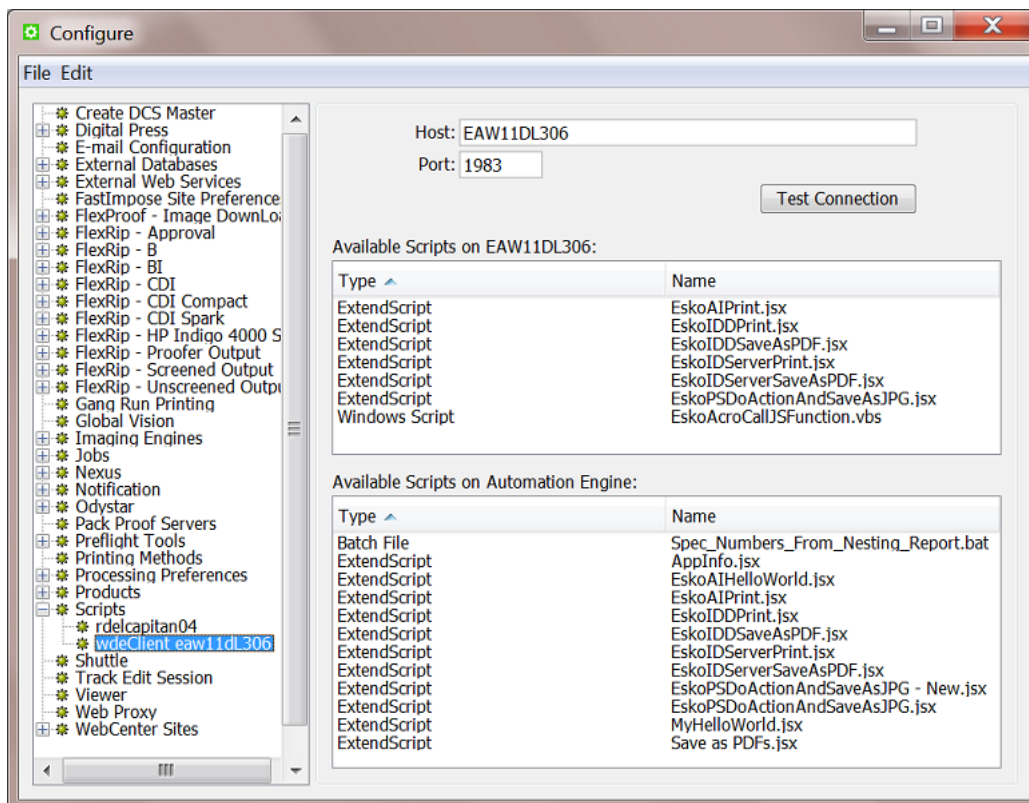

5. Give a suitable name to that Script Runner. Press **F2** or choose **File > Rename**.
6. In the **Host** field, enter the computer name or IP address of the Script Runner computer.
7. Enter the **Port** used to connect this computer to your Automation Engine server.  
By default, this is 1983.
8. **Agent:** In an AE SaaS setup, the communication between a local Script Runner and the AE server in the data center happens via a local Agent. Select an Agent from the list. Learn more in the [chapter on SaaS](#) and in [The Run Script Task](#) on page 1922.
9. Click **Test Connection**. You should now see a list of all available scripts on that computer or see a message 'No scripts available'.

These are the scripts that the *Run Script Task* will let you choose from when you have selected that Script Runner configuration in the ticket.

You can store scripts on a local client (Script Runner) or centrally on the Automation Engine server:

- **Local:** You can store scripts on your local client computer on the folder specific for script type. But note that Automation Engine does not back up these local scripts. It can be useful however to only have them local when you are still writing and testing a script or when you do not intend to give access to other Script Runners in your network.



**Note:** The default location on a client computer is (macOS) /Library/Scripts/ Esko and (Windows) C:\Esko\bg\_data\_fastserverscrrunnt\_v100\Scripts.

- **Central:** Alternatively, you can store your scripts in a central Automation Engine system folder. This option is suitable when you want to make your scripts available to **all** configured Script Runners. They will then also be part of your Automation Engine backup.



**Note:** The default location on the AE server is C:\Esko\bg\_data\_fastserver\_v100\Scripts. The subfolder names indicate the type of script.

10. Choose **Save** (from the menu of the Configure panel).
11. Select the Configure panel's category **Scripts** (not an item you added, but one level higher). On this level you see a dialog where you can choose **Download Scripts** to download all scripts from all configured Script Runner tool(s) and centralize them onto the Automation Engine server. This is done to have a central library that will also be part of your *server configuration backup*.



**Note:** When local scripts would overwrite central ones, you will be asked to confirm.

## 25.5. The Run Script Task



**Note:** Learn about the concept and the setup of custom scripts in *Scripting Concept* on page 1917.

This task contacts a *Script Runner tool* to run a script on the input file(s).



**Note:** Since AE 22.03, this task can also be started on an empty token (for example without input files).

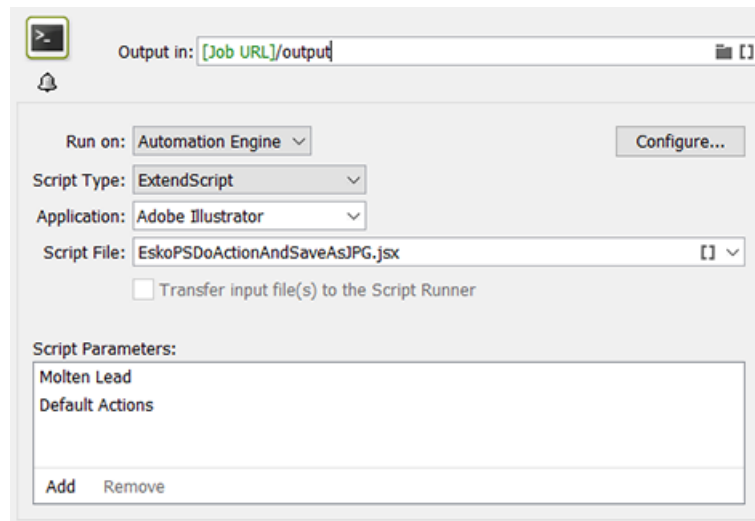

1. **Run on:** Choose the **Script Runner** tool that you *configured in the Configure panel*.
2. Select the **Script Type**. The types are different, depending if the selected Script Runner runs on a macOS or a Windows computer:



a) Script Runner on macOS: You can choose from

- **AppleScript**
- **Shell Script**
- **ExtendScript.**
- **PowerShell Script**



**Note:** On macOS, PowerShell has to be installed. As long as PowerShell is not installed on a Mac script runner node, it will not show up in the list of script types. Installing PowerShell on macOS is documented on Microsoft web pages, for example [these](#).

b) Script Runner on Windows: You can choose from

- **Batch File**
- **ExtendScript**
- **Windows Script**
- **Windows Script (32-bit).**



**Note:** Since AE 16.1, you can only install the Script Runner tool on a 64 bit host, but you can still run 32 bit Windows scripts by specifying the script type as 'Windows Script (32 bit)'.

- **PowerShell Script**



**Note:** On Windows, PowerShell comes with the OS. In most cases you get an old version like v5.1, but you can manually update to a recent version (for example v7.2)

3. Select the **Application**. This field helps to find the right application, especially when you have multiple versions installed. The drop down list is a default list that you can edit.

- On macOS, this is the (original) name of the .app file of that application
- On Windows, this is the "Target location" that appears when you ask the "Properties" of that application. An example:

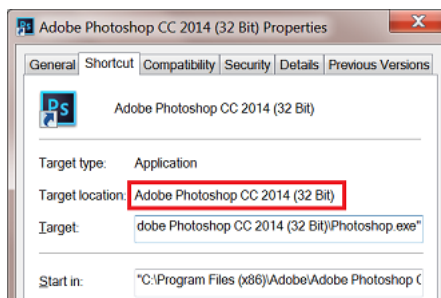



**Tip:** It is possible that you do not have to enter the full name, but minimally the part that will help the task to recognize which of the multiple versions you want. For example when you both have a CS and a CC version, then the year and the bit version do not have to be mentioned extra (because those are only mentioned after the 'CS' or 'CC' part).

4. Select the **Script File**. You can select one from the drop-down list, enter a path or/and use SmartNames.

**5. Transfer input file(s) to the Script Runner:**

- When not selected, the Script Runner will receive a file specification referring to a file on an Automation Engine Container.
- When selected, the input file(s) are transferred to the Script Runner computer through the connection made by the server when sending the script instructions.



**Warning:** When selected, any files referenced from the input files are **not** transferred.

This option is:

- disabled and selected in an AE SaaS setup (the use of an Agent requires the input files to be transferred to the Script Runner). Be aware of the above mentioned limitation regarding references.
  - disabled and deselected when the script is run on the Automation Engine server itself.
6. When the script needs one or more optional parameter(s), enter them in **Script Parameters**. Click **Add** and type the parameter.



**Note:** Learn more details and see some examples in the next pages.

## 25.6. Script Runner on macOS - Examples



**Warning:** These sample scripts are provided as-is with no warranty of fitness for a particular purpose. These scripts are solely intended to demonstrate techniques for accomplishing common tasks. Additional script logic and error-handling may need to be added to achieve the desired results in your specific environment.

It is up to the user to verify that his intended use of the offered automation functionality is compliant with any third party license agreement and/or other restrictions applicable to any non-Esko products.

### 25.6.1. AppleScript - Example 1

AppleScript is a scripting language that enables direct control of script-able applications and of many parts of the macOS. An AppleScript-able application is one that makes its operations and data available in response to AppleScript messages, called Apple events.

We recommend using AppleScript because:

- it is highly integrated into the macOS
- it is supported by a lot of third party applications
- it very accessible to scripting beginners.

1. Open the AppleScript Editor and add following code:

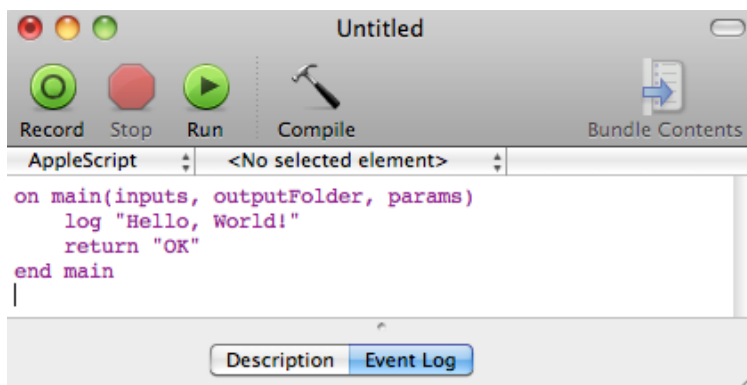

Option	Description
main	This function will be called by the Script Runner. Only the code in this main function gets executed.
inputs	The first argument of the main function: a list of input file paths (type: list of strings).
outputFolder	Second argument of the main function: the folder where AE expects the script's result files. AE will continue the flow with the files you write in this folder. If you leave this folder empty, AE will continue the flow with the inputs of the Run Script task (type: string).
params	Third argument of the main function: additional script parameters injected into the script via the Run Script ticket (type: list of strings).
log	Extra log information in the Run Script task details.
return "OK"	This will communicate to the <b>Run Script</b> task that everything went fine. Other possibilities are <code>return "Warning"</code> and <code>return "Error"</code> .

2. Save this code as an AppleScript text file in the Script Runner's AppleScript folder (**default: / Library/Scripts/Esko/AppleScript**) or in the Automation Engine AppleScript folder.

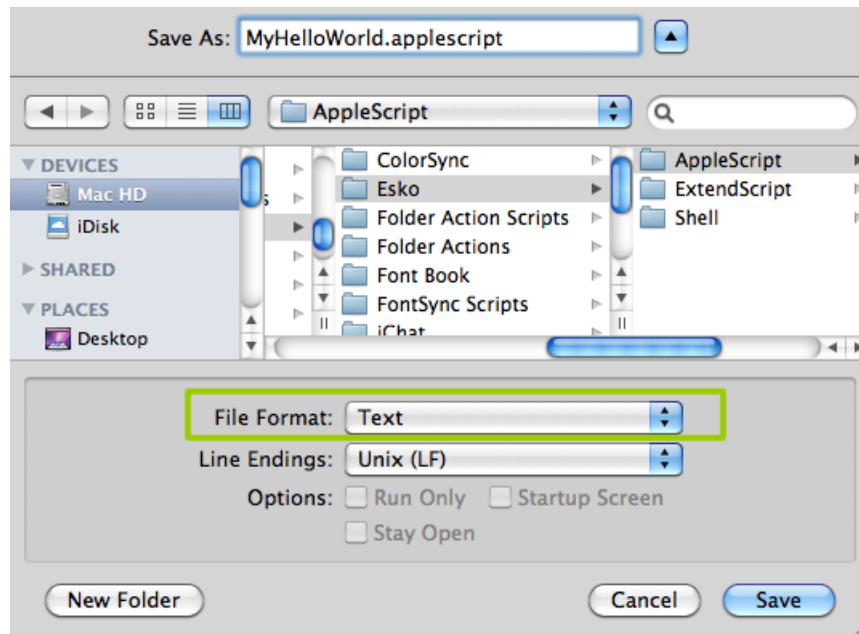

**Note:** Script Runner supports 'Text' format. Therefore it is essential to change the file format to 'Text'.

3. You can add following code to test this script locally in the AppleScript Editor. Save the file and click Run to execute the script.

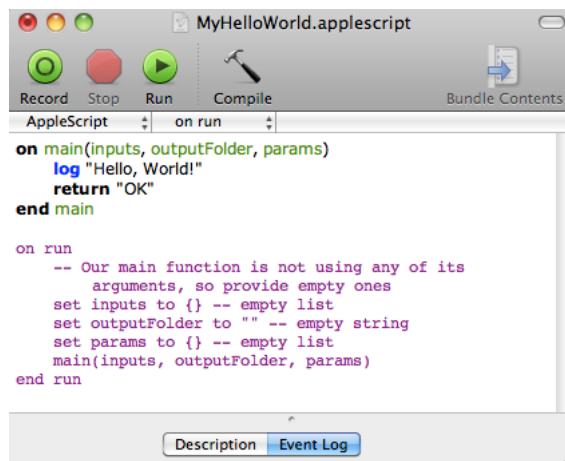

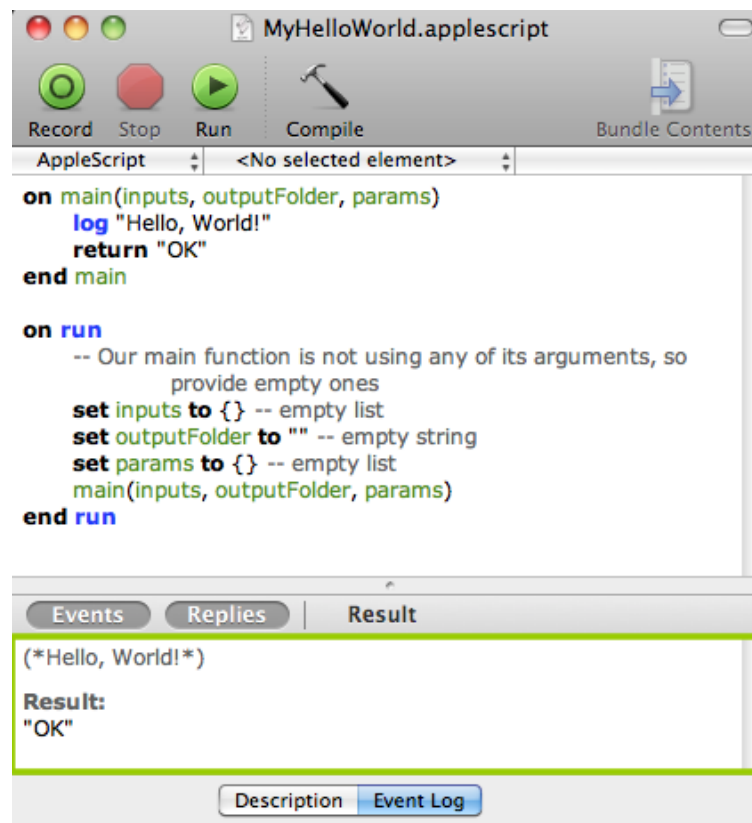

Notice the 'Hello, World!' and 'OK' result in the event log. The Script Runner does not interpret the test code in your script. It will execute the contents of the main function and ignore the rest. You can keep any test code for future local testing.

4. In the Pilot, go to **Files** view where you can select a file and open a **New Task**. Choose the **Run Script** task, modify its settings and launch the task.

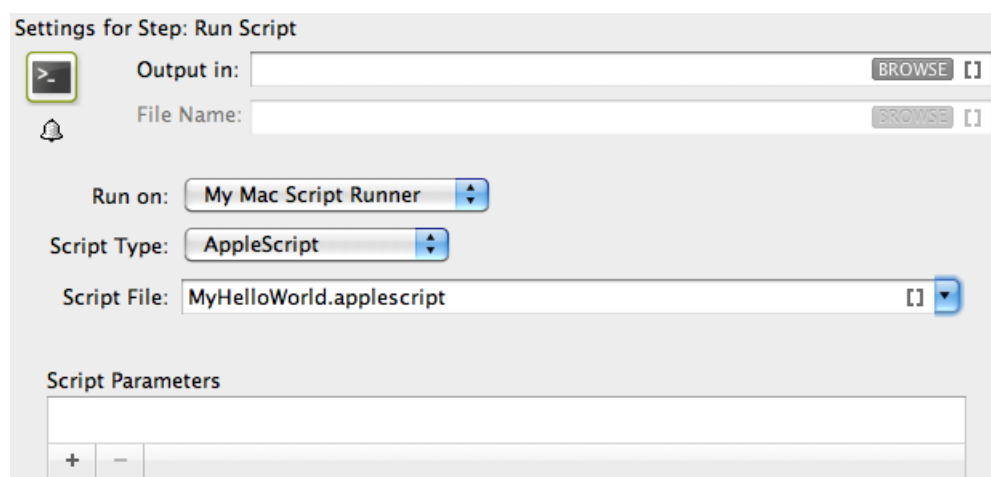

Learn more in [The Run Script Task](#) on page 1922.

Note that the 'Hello, World!' in the task details and 'OK' state correspond with log "Hello, World!" and 'return "OK"' in the script.

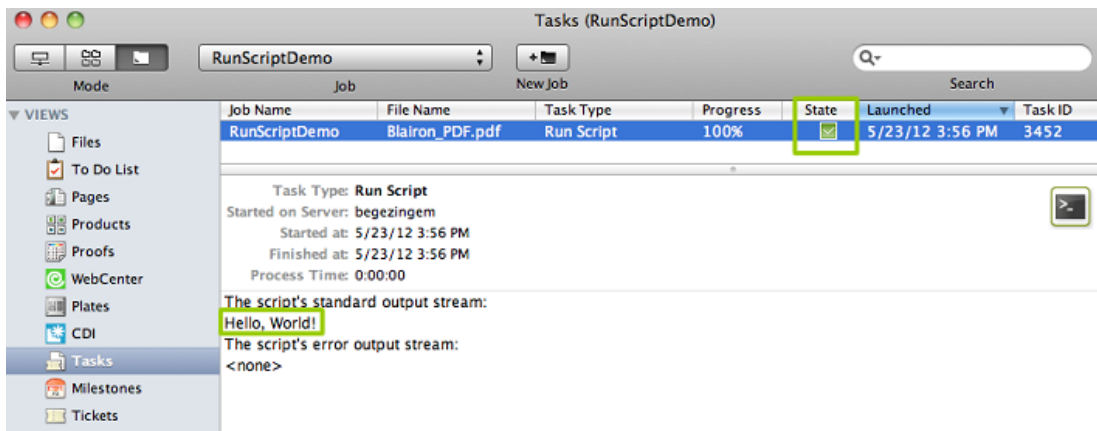

### 25.6.2. AppleScript - Example 2

In this example, we use AppleScript to copy every input file with a size smaller than the size specified in the script parameters to the output folder. To do that, we use `inputs`, `outputFolder` and `params` in the AppleScript.

First, we illustrate how to duplicate files without the size restriction and then we proceed with the actual case.

1. Open the AppleScript Editor and add the below shown code. This code is aimed to iterate through the list of inputs. It enables you to handle the inputs one by one, via the 'input' variable.

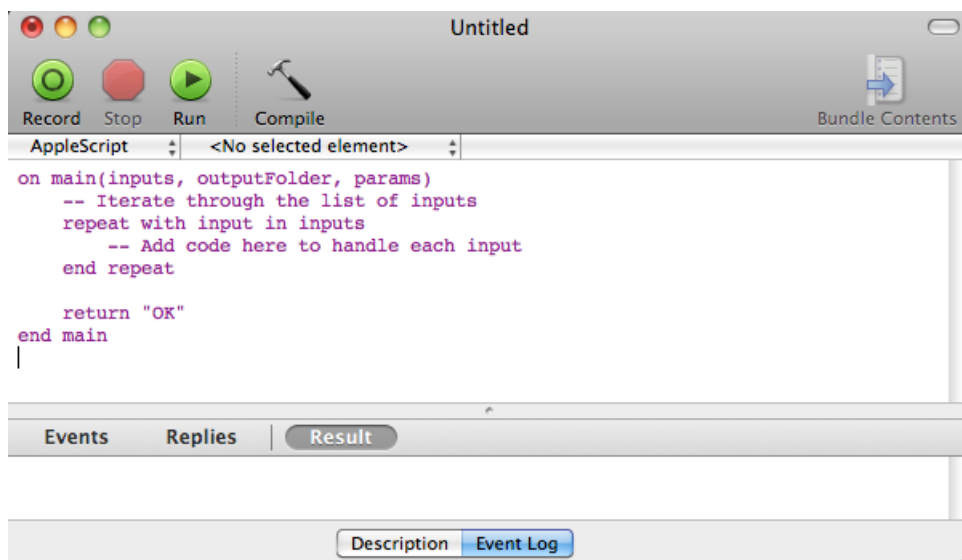

2. You can modify the Script as shown below to duplicate the files to a specified output folder without size restrictions. Save this code as an AppleScript text file in the default AppleScript folder of Script Runner (default: **/Library/Scripts/Esko/AppleScript**) or in the Automation Engine AppleScript folder.

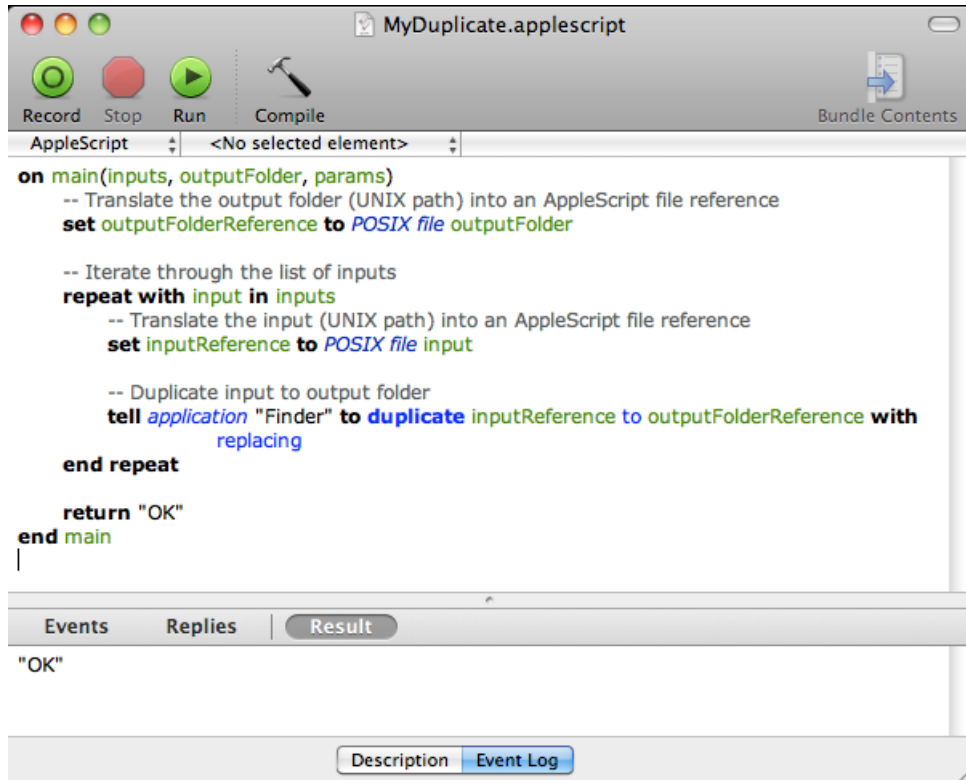

3. Add the file size check in the code as shown below. This will duplicate the file when the input file size is smaller than the maximum size from the script parameters. If this condition is not met, it will add an entry in the log and there will be "Warning". Save the file.

```

on main(inputs, outputFolder, params)
    set returnValue to "OK"

    -- Translate the output folder (UNIX path) into an AppleScript file reference
    set outputFolderReference to POSIX file outputFolder

    -- Get the maximum size from the script parameters and convert from
    megabyte to bytes
    set maxSize to (item 1 of params) * 1000000

    -- Iterate through the list of inputs
    repeat with input in inputs
        -- Translate the input (UNIX path) into an AppleScript file reference
        set inputReference to POSIX file input

        -- Get the size of the input
        set inputSize to size of (info for inputReference)

        -- Check whether the input is OK to duplicate
        if inputSize < maxSize then
            -- Duplicate input to output folder
            tell application "Finder" to duplicate inputReference to
                outputFolderReference with replacing
        else
            log input & " is too big to duplicate"
            set returnValue to "Warning"
        end if
    end repeat

    return returnValue
end main

```

4. In the Pilot, go to **Files** view, select the files to be copied and open a **New Task**. Choose the **Run Script** task, modify its settings and launch. This modified ticket will duplicate every selected file which is smaller than 10 MB to the current job's Script Output folder. In this example, we executed this task for two files (BigBox.pdf: 22 MB and SmallLabel.pdf: <1 MB).



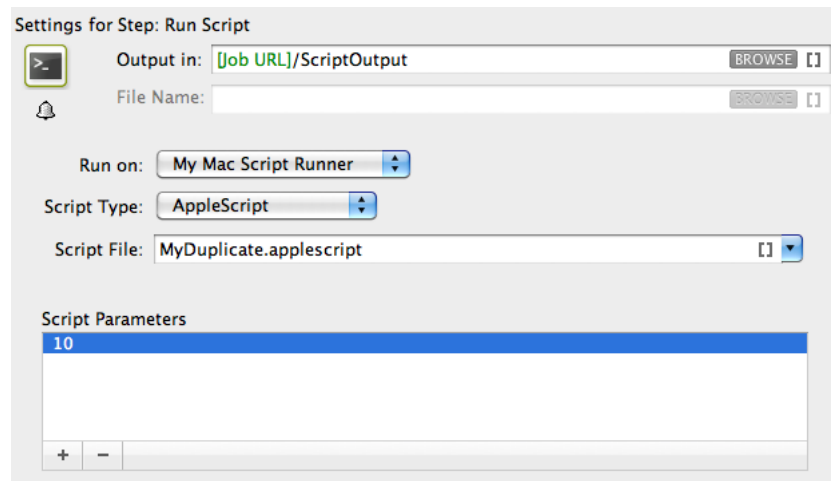

'SmallLabel.pdf' is duplicated into the job's 'ScriptOutput' folder. 'BigBox.pdf' was too big to duplicate (> 10 MB). Therefore, the task ended in a 'Warning' state and added an entry in the task details.

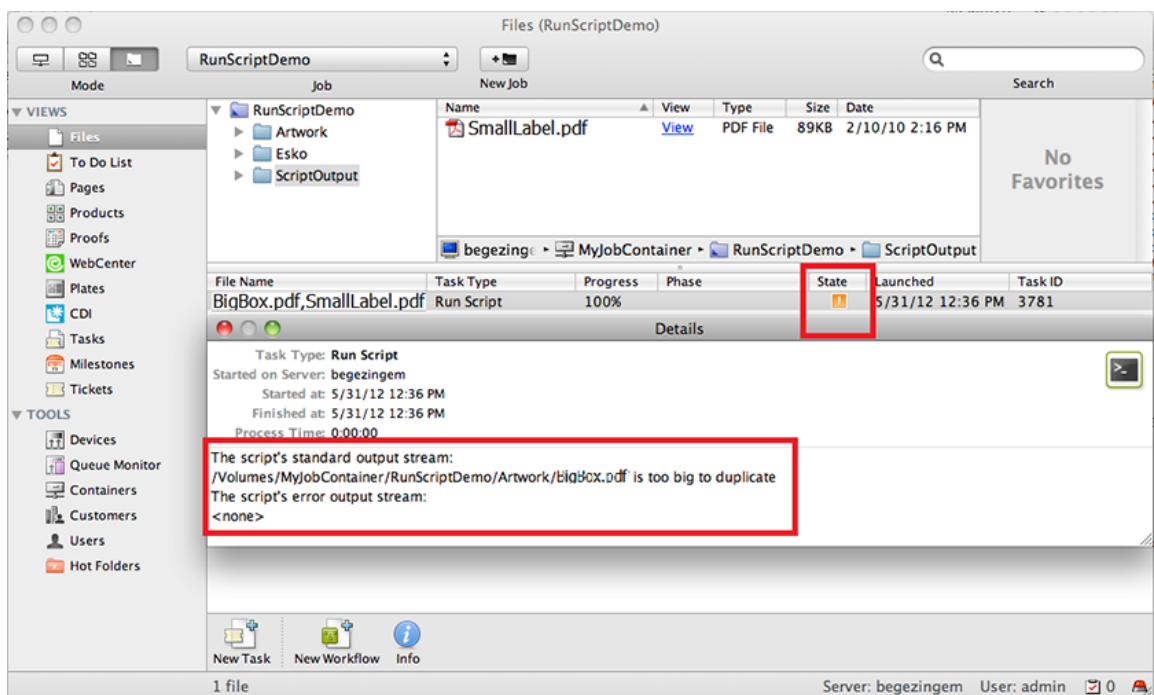

### 25.6.3. Shell Script - Example

In this example, we use a Shell Script to copy every input file with a size smaller than the specified size in the script parameters to the output folder.

1. Open a text editor and add the below shown code. When the Script Runner executes this code, \$1 (the script's first argument) will contain a string of input file paths separated by : . The code splits up the concatenated file paths into a real list. This helps to iterate through the list and handle the **Run Script** task's inputs one by one.

```
#!/bin/bash

# Split up the input file paths into a list
# via the Internal Field Separator (IFS)
OLDIFS=$IFS # Always keep the original IFS
IFS=":" # Now set it to ':'
# Split up '$1' into the 'inputs' variable, with ':' as separator
inputs=( $1 )
IFS=$OLDIFS # Restore the original IFS

inputCount=${#inputs[@]}

# Iterate through the list of inputs
for (( i=0; i<${inputCount}; i++ ));
do
    # Add code here to handle each input
done

exit 0
```

2. Write the code as shown below. This script copies the input to the output folder if the input's file size is smaller than the maximum size from the script parameters. If the size of the file is bigger, it adds an entry in the log and makes sure the task ends in 'Warning' state (via exit value '1'). Save this code as a text file to the Script Runner's Shell folder (default: **/Library/Scripts/Esko/Shell**) or to the Automation Engine Shell folder.

```
#!/bin/bash

# Split up the input file paths into a list
# via the Internal Field Separator (IFS)
OLDIFS=$IFS # Always keep the original IFS
IFS=":" # Now set it to ':'
# Split up '$1' into the 'inputs' variable, with ':' as separator
inputs=( $1 )
IFS=$OLDIFS # Restore the original IFS

inputCount=${#inputs[@]}

# Get the output folder
outputFolder=$2

# Get the maximum size from the script parameters
# and convert from megabyte to bytes
maxSize=`expr $3 \* 1000000`

exitValue=0

# Iterate through the list of inputs
for (( i=0; i<${inputCount}; i++ ));
do
    input=${inputs[$i]}
    # Get the size of the input
    inputSize=`ls -l "$input" | awk '{print $5}`

    # Check whether the input is OK to copy
    if [ $inputSize -lt $maxSize ]; then
        # Copy input to output folder
        cp -f "$input" "$outputFolder"
    else
        echo "$input is too big to duplicate"
        exitValue=1
    fi
done

exit $exitValue
```

\$1	First Shell Script argument: the Run Script task's inputs. A string of input file paths, separated by ':'.
\$2	Second Shell Script argument or output folder: This is the folder where Automation Engine expects the script's result files. AE will continue the flow with the files you write in this folder. If you leave this folder empty, AE will continue the flow with the inputs of the Run Script task.
\$3, \$4, \$5, ...	Remaining Shell Script arguments: additional script parameters which you can inject into the script via the Run Script task.

exitValue	Ending Status of the task
0	OK
1	Warning
2	Error

- In the Pilot, go to **Files** view, select a file and open a **New Task**. Choose the **Run Script** task, modify its settings and launch. This modified ticket will duplicate every selected file which is smaller than 10 MB to the current job's Script Output folder. In this example, we executed this task for two files (BigBox.pdf: 22 MB and SmallLabel.pdf: <1 MB).

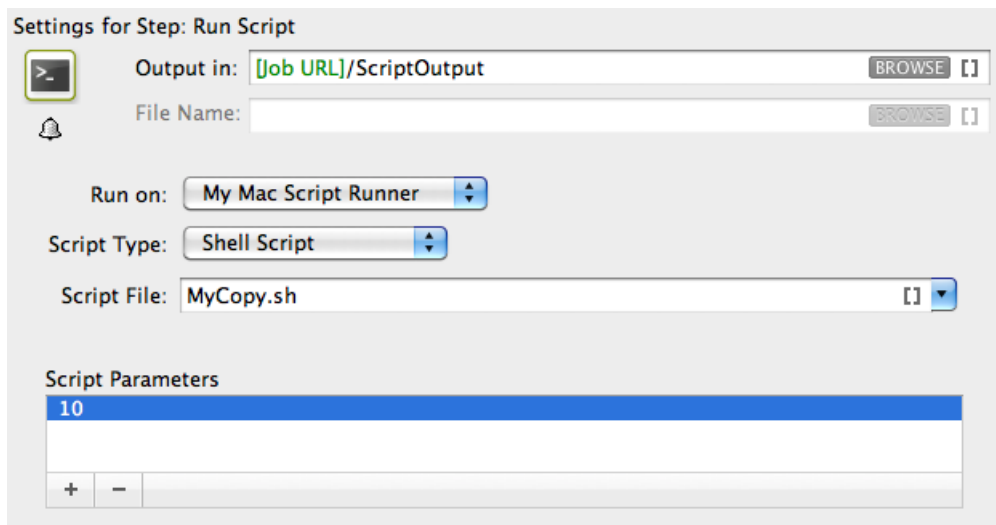

'SmallLabel.pdf' is duplicated into the job's Script Output folder. 'BigBox.pdf' was too big to duplicate (> 10 MB). Therefore, the task ended in 'Warning' state (due to `exitValue=1` in the code) and added an entry in the task details.

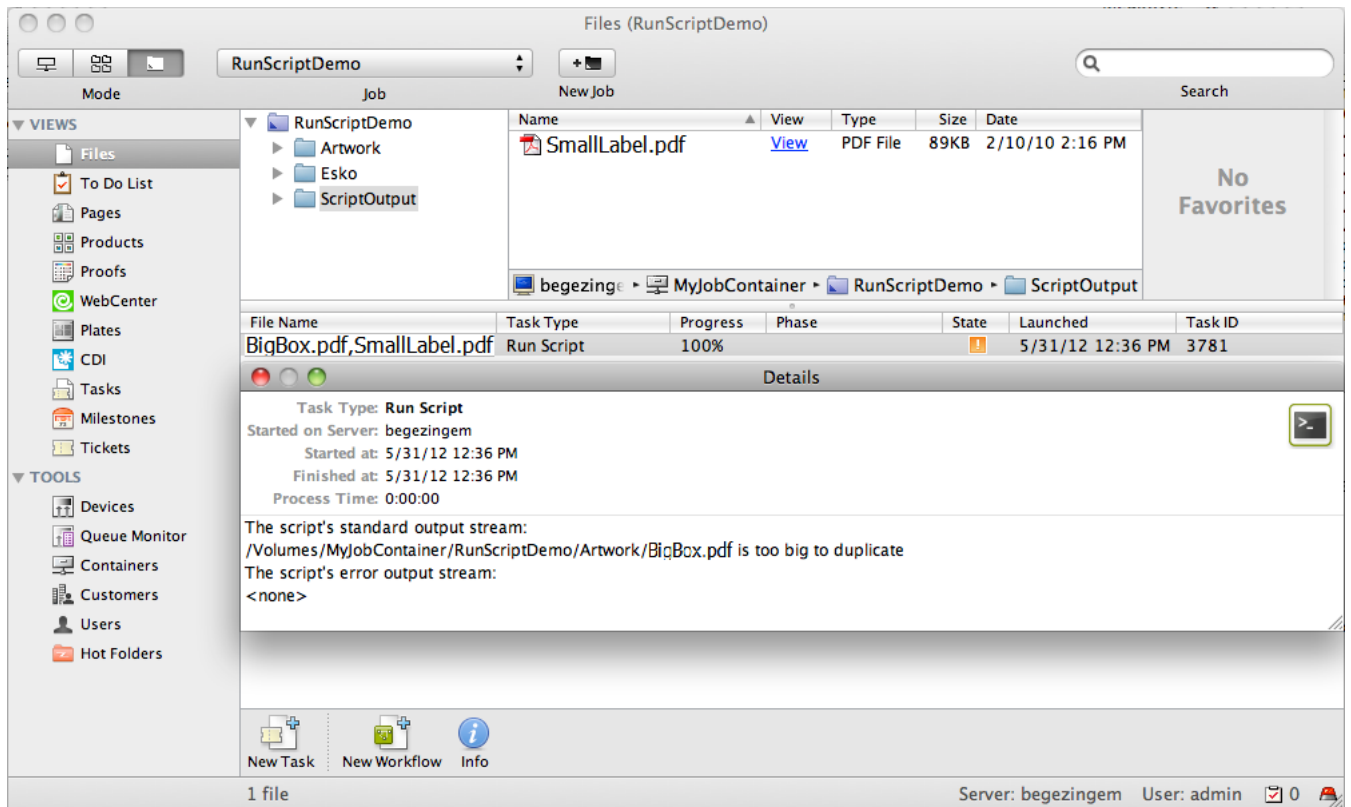

## 25.7. Script Runner on Windows - Examples



**Warning:** These sample scripts are provided as-is with no warranty of fitness for a particular purpose. These scripts are solely intended to demonstrate techniques for accomplishing common tasks. Additional script logic and error-handling may need to be added to achieve the desired results in your specific environment.

It is up to the user to verify that his intended use of the offered automation functionality is compliant with any third party license agreement and/or other restrictions applicable to any non-Esko products.

### 25.7.1. Windows Script Example 1

1. Open a text editor and add the below shown code:

```

1
2
3 Function Main(inputs, outputFolder, params)
4     WScript.Echo "Hello, World!"
5
6     ' Set the function's return value.
7     Main = "OK"
8 End Function

```

Function Main	The function that will be called by the Script Runner. Script Runner executes only the code in this main function.
inputs	First argument of main function: a list of input file paths (type: list of strings).
outputFolder	Second argument of the main function: the folder where AE expects the script's result files. AE will continue the flow with the files you write in this folder. If you leave this folder empty, AE will continue the flow with the inputs of the Run Script task (type: string).
params	Third argument of the main function: additional script parameters injected into the script via the Run Script ticket (type: list of strings).
WScript.Echo	This puts some extra log info in the Run Script task details and log. This call prints text to the Console and adds a newline character without Script Runner context.
Main = "OK"	This communicates to the <b>Run Script</b> task that everything went fine. Other possibilities are Main = "Warning" and Main = "Error".

2. You can test this script locally by adding the code shown below. Save this file. Open command prompt. Change the directory to the script's parent directory. Run command 'cscript MyHelloWorld.vbs'.

```

1
2
3 Function Main(inputs, outputFolder, params)
4     WScript.Echo "Hello, World!"
5
6     ' Set the function's return value.
7     Main = "OK"
8 End Function
9
10 ' Our main function is not using any of its arguments,
11 ' so provide empty ones.
12 Dim inputs()
13 Dim outputFolder
14 Dim params()
15 Main inputs, outputFolder, params
16
length: 314 Ln: 16 Col: 1 Sel: 164
    
```

This will produce the output 'Hello, World!' to the console. The Script Runner does not interpret the test code in your script. It will execute the contents of the main function and ignore the rest. You can keep your test code for future local testing.

3. In a Pilot, go to **Files** view, select a file and open a **New Task**. Choose the **Run Script** task, modify its settings and launch the task.

Settings for Step: Run Script

Output in:  BROWSE [ ]

File Name:  BROWSE [ ]

Run on: My Win Script Runner [v]

Script Type: Windows Script [v]

Script File: MyHelloWorld.vbs [v]

Script Parameters

+ -

Note that the 'Hello, World!' in the task details and 'OK' state are corresponding with WScript.Echo "Hello, World!" and Main = "OK" in the script.

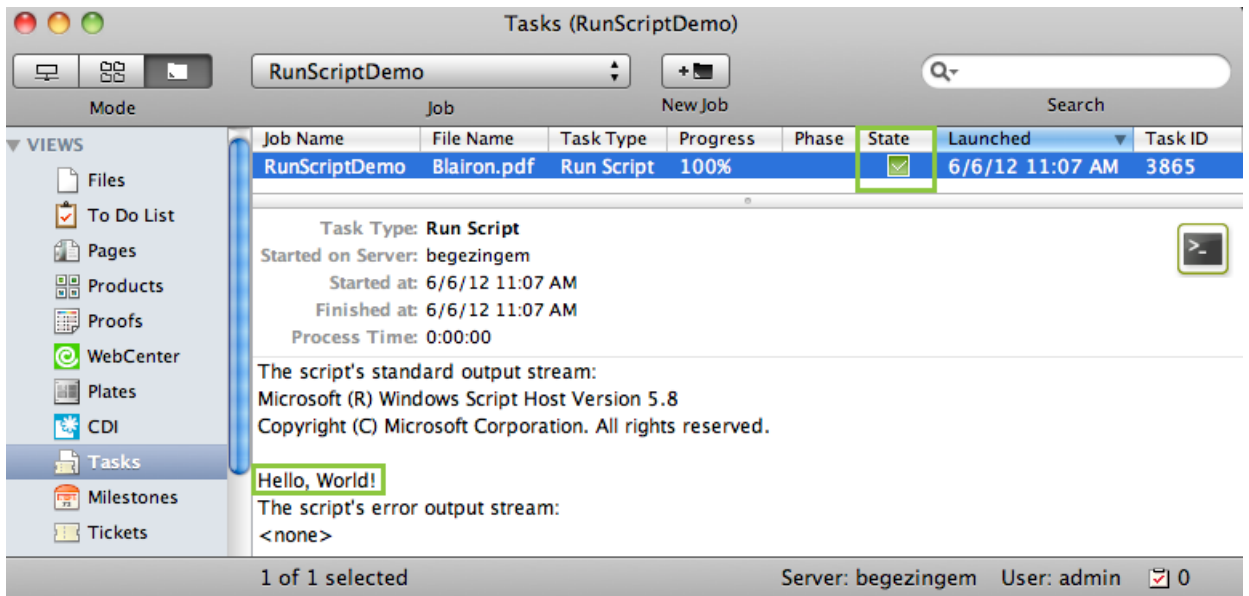

### 25.7.2. Windows Script Example 2

In this example, we use Windows Script to copy every input file with a size smaller than the size specified in the script parameters to the output folder. We use `inputs`, `outputFolder` and `params` in the script to achieve our objective.

First, we illustrate how to duplicate files without the size restriction and then we proceed with the actual example.

1. Open a text editor and add the below shown code. This code is aimed to iterate through the list of inputs. It enables you to handle the inputs one by one, via the 'input' variable.

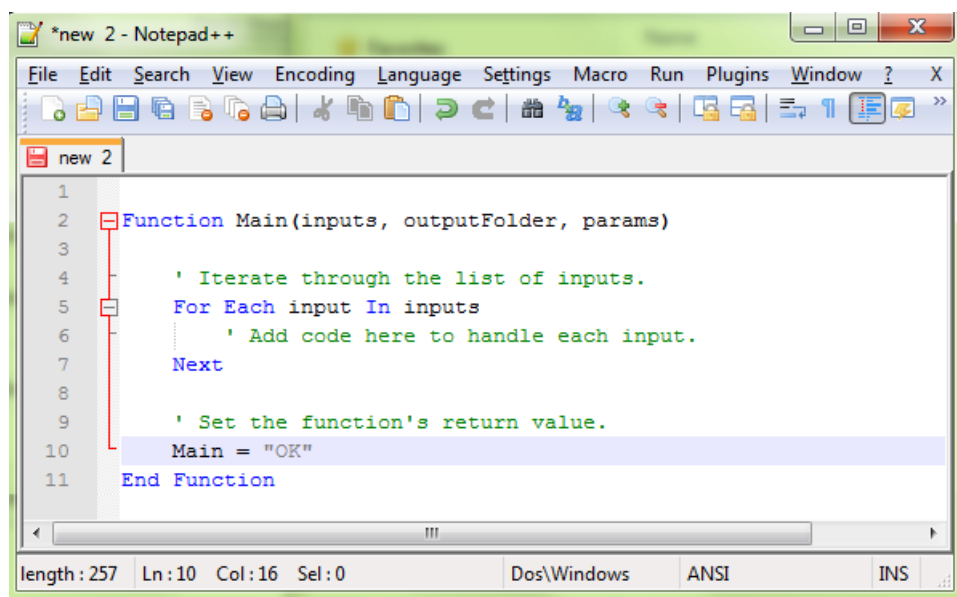



2. You can modify the Script as shown below to duplicate the files to a specified output folder without size restrictions. Save this code as a text file with '.vbs' extension (VBScript) in the Windows Script folder of Script Runner (default: **C:\Esko\bg\_data\_fastserverscrunnt\_v100\Scripts\WindowsScript**) or in the Automation Engine WindowsScript folder.

```

1
2  Function Main(inputs, outputFolder, params)
3
4      ' Create the file system object that is going to do the copying.
5      Dim filesystems
6      Set filesystems = CreateObject("Scripting.FileSystemObject")
7      WScript.Echo "File system object created"
8
9      ' Iterate through the list of inputs.
10     For Each input In inputs
11         ' Copy input to output folder.
12         Dim outputFile
13         outputFile = outputFolder & "\" & filesystems.GetFileName(input)
14         filesystems.CopyFile input, outputFile
15     Next
16
17     ' Set the function's return value.
18     Main = "OK"
19 End Function
20
length: 578 lines: 20 Ln: 14 Col: 43 Sel: 0 Dos\Windows ANSI INS

```

3. Add the file size check in the code as shown below. This will duplicate the file when the input file size is smaller than the maximum size from the script parameters. If this condition is not met it will add an entry in the log and there will be "Warning". Save the file.

```

1
2 Function Main(inputs, outputFolder, params)
3     Dim returnValue
4     returnValue = "OK"
5
6     ' Get the maximum size from the script parameters
7     ' and convert from megabyte to bytes.
8     Dim maxSize
9     maxSize = params(0) * 1000000
10
11    ' Create the file system object that is going to do the copying.
12    Dim filesystems
13    Set filesystems = CreateObject("Scripting.FileSystemObject")
14    WScript.Echo "File system object created"
15
16    ' Iterate through the list of inputs.
17    For Each input In inputs
18        ' Turn the input path into a file object.
19        Dim inputReference
20        Set inputReference = filesystems.GetFile(input)
21
22        ' Check whether the input is OK to copy.
23        If inputReference.Size < maxSize Then
24            ' Copy input to output folder.
25            Dim outputFile
26            outputFile = outputFolder & "\" & filesystems.GetFileName(input)
27            filesystems.CopyFile input, outputFile
28        Else
29            WScript.Echo input & " is too big to copy"
30            returnValue = "Warning"
31        End If
32    Next
33
34    ' Set the function's return value.
35    Main = returnValue
36 End Function
37
length:1046 lines:37 Ln:31 Col:15 Sel:0 Dos\Windows ANSI INS

```

4. In a Pilot, go to **Files** view, select the files to be copied and open a **New Task**. Choose the **Run Script** task, modify its settings and launch. This modified ticket will duplicate every selected file which is smaller than 10 MB to the current job's 'ScriptOutput' folder. In this example, we executed this task for two files (BigBox.pdf: 22 MB and SmallLabel.pdf: <1 MB).

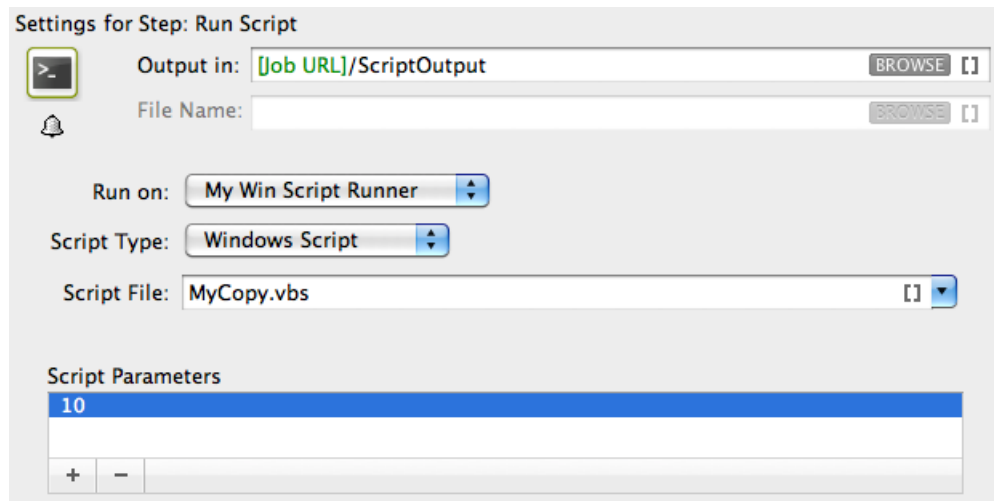

'SmallLabel.pdf' is duplicated into the job's 'ScriptOutput' folder. 'BigBox.pdf' was too big to duplicate (> 10 MB). Therefore, the task ended in 'Warning' state and added an entry in the task details.

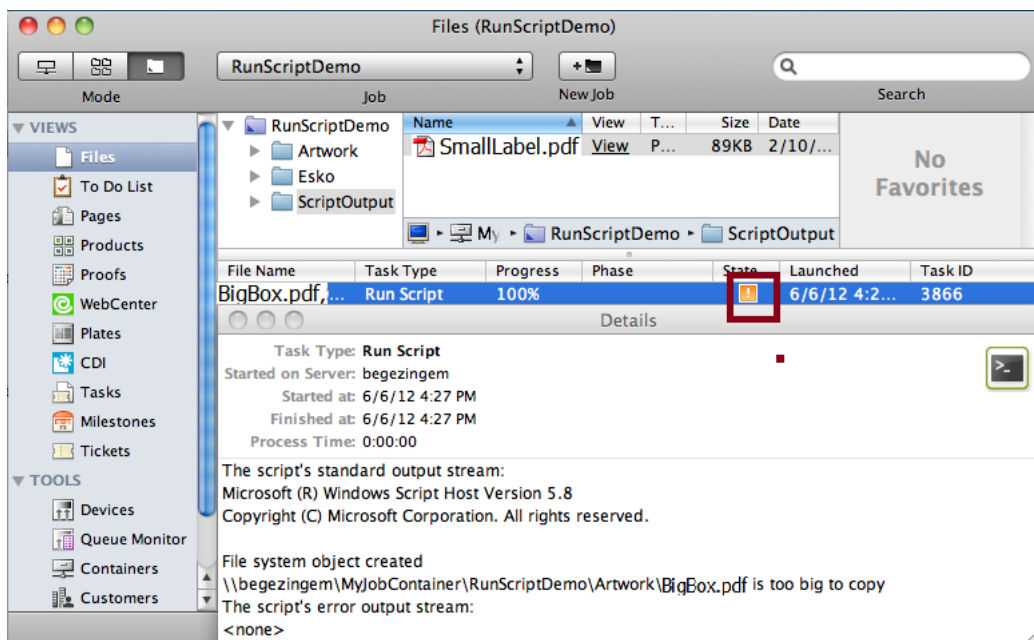

### 25.7.3. Batch File Example

In this example, we use a Batch file to copy every input file with a size smaller than the size specified in the script parameters to the output folder.

1. Open a text editor and add the below shown code. This code is aimed to iterate through the list of inputs. It enables you to handle the inputs one by one, via the command %1 (the script's first argument) will contain a string of input file paths, separated by ';'.

```

1 @echo off
2 rem First script argument contains the input file paths
3 set inputs=%1
4 rem Trim surrounding quotes
5 for /f "usebackq tokens=*" %%a in ('%inputs%') do set inputs=%%~a
6
7 set exitValue=0
8
9 rem Iterate through the input file paths which are separated by ';'
10 :ITERATE_INPUTS
11 if "%inputs%"==" " goto EXIT
12 for /f "tokens=1 delims=" %%a in ("%inputs%") do call :HANDLE_INPUT "%%a"
13 for /f "tokens=1* delims=" %%a in ("%inputs%") do set inputs=%%b
14 goto ITERATE_INPUTS
15
16 :HANDLE_INPUT
17 echo Add code here to handle each input
18 goto :eof
19
20 :EXIT
21 exit %exitValue%
22

```

Bat length: 575 lines: 22      Ln: 22 Col: 1 Sel: 0      Dos\Windows      ANSI      INS

2. You can modify the Script as shown below to duplicate the files to a specified output folder with a size check. Save this code as a text file with '. bat' extension in the Script Runner Batch File Folder (default: **C:\Esko\bg\_data\_fastserverscrunnt\_v100\Scripts\BatchFile**) or in the Automation Engine 'BatchFile' folder.

```

C:\Esko\bg_data_fastserverscrunt_v100\Scripts\Batch\myCopy.bat - Notepad++
File Edit Search View Encoding Language Settings Macro Run Plugins Window ?
myCopy.bat
1 @echo off
2 rem First script argument contains the input file paths
3 set inputs=%1
4 rem Trim surrounding quotes
5 for /f "usebackq tokens=*" %%a in ('%inputs%') do set inputs=%%~a
6
7 rem Get the output folder
8 set outputFolder=%2
9
10 rem Get the maximum size from the script parameters
11 rem and convert from megabyte to bytes
12 set /a maxSize=%3*1000000
13
14 set exitValue=0
15
16 rem Iterate through the input file paths which are separated by ';'
17 :ITERATE_INPUTS
18 if "%inputs%"==" " goto EXIT
19 for /f "tokens=1 delims=;" %%a in ("%inputs%") do call :HANDLE_INPUT "%%a"
20 for /f "tokens=1* delims=;" %%a in ("%inputs%") do set inputs=%%b
21 goto ITERATE_INPUTS
22
23 :HANDLE_INPUT
24 rem Get the size of the input
25 for %%? in (%1) do set inputSize=%%~z?
26 rem Check whether the input is OK to copy
27 if %inputSize% lss %maxSize% (
28     rem Copy input to output folder
29     copy /y %1 %outputFolder%
30 ) else (
31     echo %1 is too big to copy
32     set exitValue=1
33 )
34 goto :eof
35
36 :EXIT
37 exit %exitValue%
38
Bat length: 973 lines: 38 Ln: 38 Col: 1 Sel: 0 Dos\Windows ANSI INS

```

%1	First batch file argument: the Run Script task's inputs. A string of input file paths, separated by ';'.
%2	Second batch file argument or output folder: the folder where AE expects the script's result files. AE will continue the flow with the files you write in this folder. If you leave this folder empty, AE will continue the flow with the inputs of the Run Script task.

%3, %4,%5...	Remaining batch file arguments: additional script parameters, injected into the script via the <b>Run Script</b> task.
--------------	------------------------------------------------------------------------------------------------------------------------

Exit value	Ending Status of the task
0	OK
1	Warning
2	Error

- In a Pilot, go to **Files** view, select the files to be copied and open a **New Task**. Choose the **Run Script** task, modify its settings and launch. This modified ticket will duplicate every selected file which is smaller than 10 MB to the current job's Script Output folder. In this example, we executed this task for two files (BigBox.pdf: 22 MB and SmallLabel.pdf: <1 MB).

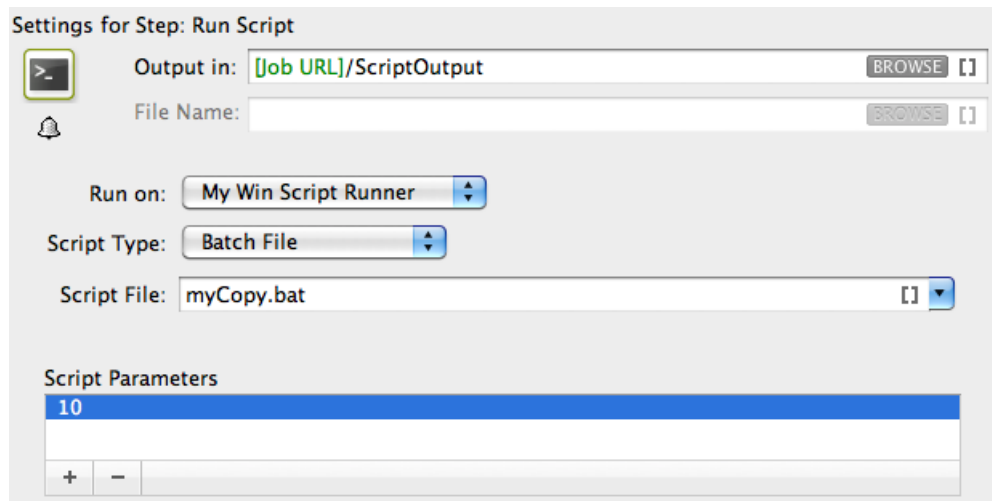

'SmallLabel.pdf' is duplicated into the job's 'ScriptOutput' folder. 'BigBox.pdf' was too big to duplicate (> 10 MB). Therefore, the task ended in 'Warning' state and added an entry in the task details.

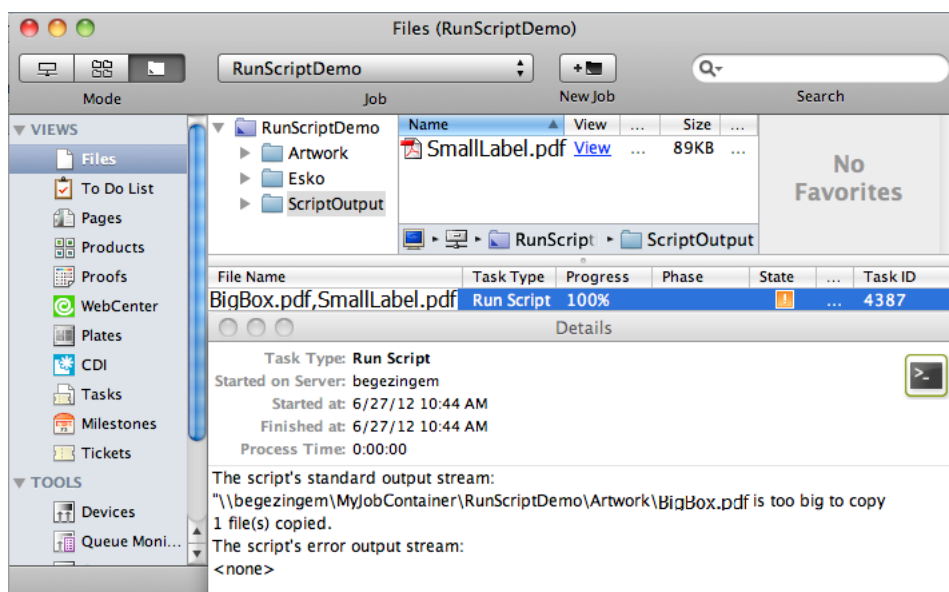

## 25.8. Using ExtendScript (macOS & Windows)

### 25.8.1. Adobe Applications on Windows: Run Script Runner as an Application (Not as a Service)

When you use ExtendScript on Windows, you can avoid problems while accessing your user specific settings such as Adobe applications' **Presets**, **Actions**, etc. by stopping the Script Runner service and **running it as an application for the logged in user (who also defined the Adobe settings)**.

Follow these steps to do this:

- Open **Start > All Programs > Esko > Automation Engine Script Runner > Preferences**.
- Stop the Script Runner and deselect **Start at login** (which actually means 'Start as service') and Close **Preferences**.
- Start it as a console application by double clicking its executable in the Script Runner's program folder > \bin\_ix86\egscriun.exe. For example C:\Esko\bg\_prog\_fastserverscrrunnt\_v141\bin\_ix86\egscriun.exe

### 25.8.2. ExtendScript in Adobe Illustrator - Example 1

ExtendScript is JavaScript extended for Adobe CS/CC applications. Adobe provides the ExtendScript Toolkit (ESTK): a complete IDE (integrated development environment) to program ExtendScript. Learn more about Adobe scripting resources in the [Adobe Scripting Center](#).



**Attention:** As mentioned in the [introduction](#), Adobe (Windows) 32 bit applications are no longer supported on a standalone Script Runner tool.

1. Open the ExtendScript Toolkit and add the below shown code. Save this code in the Script Runner's ExtendScript folder. The default location is : **/Library/Scripts/Esko/ExtendScript** for a Script Runner on Mac or **C:\Esko\bg\_data\_fastserverscrunnt\_v100\Scripts\ExtendScript** on Windows. Alternatively, you can save them in the ExtendScript folder of Automation Engine.

```

1  function main (Inputs, outputFolder, params)
2  {
3    $.writeln ("Hello, World!");
4    alert ("Another way to say: Hello, World!");
5    return "OK";
6  }
7

```

Main	This function will be called by the Script Runner. Only the code in this main function gets executed.
Inputs	First argument of main function: a list of input file paths (type: list of strings).
outputFolder	Second argument of the main function: the folder where AE expects the script's result files. AE will continue the flow with the files you write in this folder. If you leave this folder empty, AE will continue the flow with the inputs of the Run Script task (type: string).
params	Third argument of main function: additional script parameters, injected into the script via the <b>Run Script</b> ticket (type: list of strings).
\$.writeln	This writes extra log information in the Run Script task details and log. Without Script Runner context this call prints text to the Console, and adds a newline character.
alert	This registers some extra log info in the <b>Run Script</b> task details and log. Without Script Runner context this call displays an alert box.
return "OK";	This communicates to the <b>Run Script</b> task that everything went fine. Other possibilities are Return = "Warning" and Return = "Error".

2. To test the script locally in the ExtendScript Toolkit, add below shown code, save and run the script.



```

1  function main (inputs, outputFolder, params)
2  {
3      $.writeln ("Hello, World!");
4      alert ("Another way to say: Hello, World!");
5      return "OK";
6  }
7
8  // Our main function is not using any of its arguments, so you can test main without arguments
9  main ();
10

```

Execution finished. Result: OK

As a result, 'Hello, World!' and 'OK' are shown in the Console and the alert box pops up:



The Script Runner does not interpret the test code in your script. It will execute only the contents of the main function and ignore the rest. You can keep your test code for future local testing.

3. In the Pilot, go to **Files** view, select a file and open a **New Task**. Choose the **Run Script** task, modify its settings and launch the task.

Settings for Step: Run Script

Output in:  BROWSE

File Name:  BROWSE

Run on: My Mac Script Runner

Script Type: ExtendScript

Application: Adobe Illustrator

Script File: MyHelloWorld.jsx

Script Parameters

+ -

Note that the 'Hello, World!' in the task details and 'OK' state are corresponding with `$.writeln("Hello World!");` and `Return = "OK"` in the script.

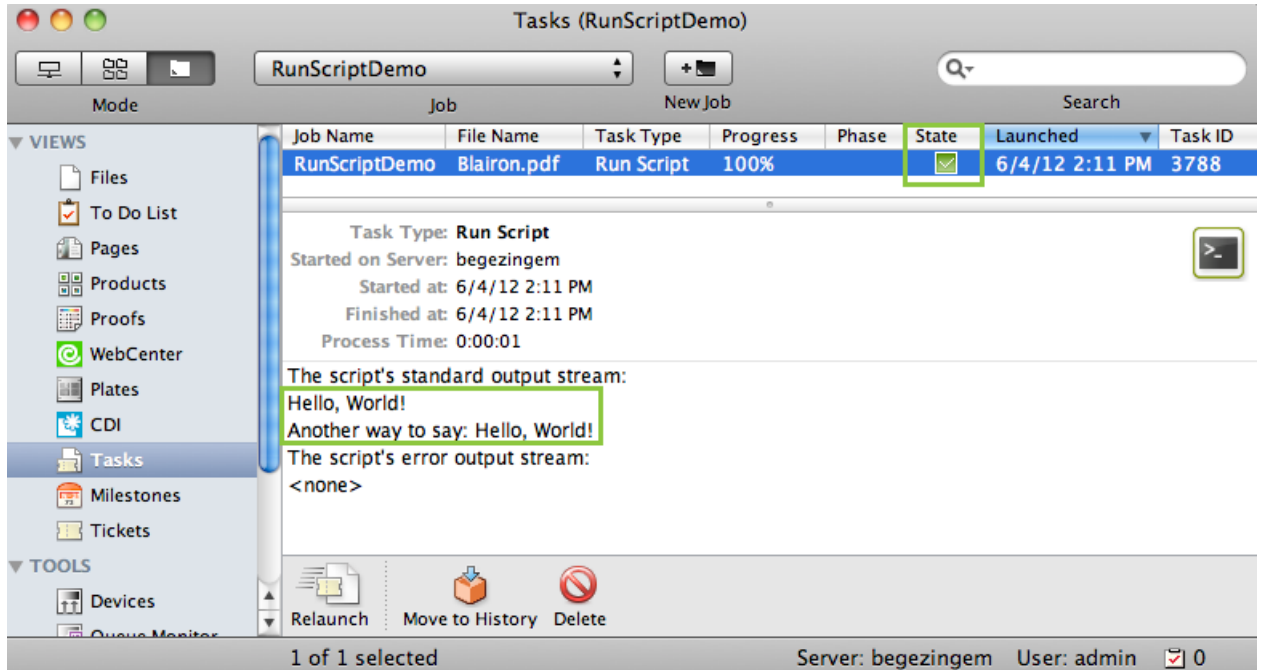

### 25.8.3. ExtendScript in Adobe Illustrator - Example 2

In this example we use ExtendScript to **Open** a file in Illustrator and print it using a **Print Preset**.



**Note:** Make sure you read this page first: [Adobe Applications on Windows: Run Script Runner as an Application \(Not as a Service\)](#) on page 1945.



**Note:** To prevent having to start up the Script Runner every time you log in, add its executable to your user's/system's Startup Items.

1. Define a **My Print Preset** in your Adobe Illustrator application.
2. Open the ExtendScript Toolkit and add the below shown code. This code is aimed to iterate through the list of inputs. It enables you to handle the inputs one by one, via the `input` variable.

```

1  function main(inputs, outputFolder, params)
2  {
3      // Iterate through the list of inputs.
4      for (i=0; i<inputs.length; i++)
5      {
6          var input = inputs[i];
7          // Add code here to handle each input.
8      }
9
10     return "OK";
11 }
12

```

The screenshot shows a code editor window titled "Source1" with a tab for "ExtendScript Toolkit CS5.5" and a file named "main". The code is a JavaScript function that takes three arguments: "inputs", "outputFolder", and "params". It uses a "for" loop to iterate through the "inputs" array. Inside the loop, it declares a variable "input" and assigns it the value of "inputs[i]". A comment indicates where to add code to handle each input. After the loop, it returns the string "OK". The editor interface includes a scrollbar and a status bar at the bottom right showing "Line 12 Column 1".

3. To print every input file using a **Print Preset** from the script parameters in the **Run Script** task, write the code as shown below. Save this code in the default ExtendScript folder (of Script Runner or of Automation Engine).

```

1  function main(inputs, outputFolder, params)
2  {
3      // First and only script parameter is the print preset.
4      var printPreset = params[0];
5
6      var returnValue = "OK";
7
8      // Iterate through the list of inputs.
9      for (i=0; i<inputs.length; i++)
10     {
11         var input = inputs[i];
12
13         try
14         {
15             // Open the input file.
16             var myDocument = app.open(File(input), DocumentColorSpace.CMYK);
17             // Create print options and set the print preset.
18             var options = new PrintOptions();
19             options.printPreset = printPreset;
20             // Print the document.
21             myDocument.print(options);
22             // Close the document without saving.
23             myDocument.close(SaveOptions.DONOTSAVECHANGES);
24         }
25         catch (e)
26         {
27             // Log problem info and set the return value to "Warning".
28             $.writeln("Problem while printing " + input);
29             $.writeln("Name: " + e.name);
30             $.writeln("Message: " + e.message);
31             returnValue = "Warning";
32         }
33     }
34
35     return returnValue;
36 }
37

```

4. In a Pilot, go to **Files** view, select a file and open a **New Task**. Choose the **Run Script** task, modify its settings and launch the task.

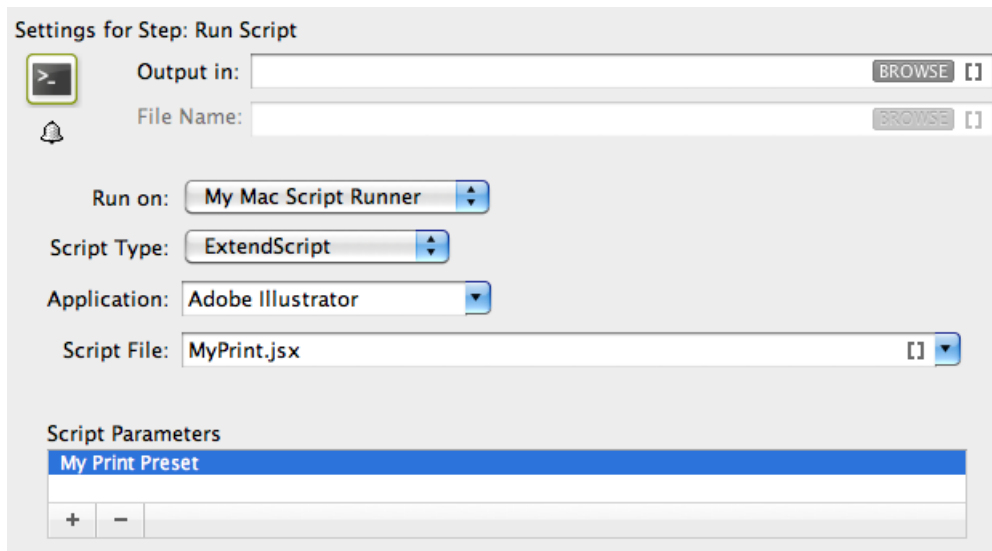

Launching this ticket will print the selected Illustrator files using the **Print Preset** specified as script parameters (My Print Preset) in the task.

### 25.8.4. ExtendScript in Adobe Photoshop - Example



**Note:** These sample scripts are solely intended to demonstrate techniques for accomplishing common tasks. Additional script logic and error-handling may need to be added to achieve the desired results in your specific environment.

It is up to the user to verify that his intended use of the offered automation functionality is compliant with any third party license agreement and/or other restrictions applicable to any non-Esko products.

In this example, we illustrate a script that performs a Photoshop "action" and then produces a JPEG output. The script 'EskoPSDoActionAndSaveasJPG.jsx' is available from the sample scripts subfolder "ExtendScript" in /Library/Scripts/Esko (Mac) or C:\Esko\bg\_data\_fastserverscrrunnt\_v100\Scripts (Windows).

1. You have to save the **Set** and **Action** in Photoshop. In this example we are using an action named "Molten Lead" which is one of the "Default Actions" (folder) as **Set** (variable 2) and **"Molten Lead"** as **Action** (variable 1).
2. You can open the script with ExtendScript Toolkit to edit the script if required. However, in this sample, we do not need to edit the script.

```

ExtendScript Toolkit CS4
main

/**
 * Sample scripts are provided as-is with no warranty of fitness for a particular purpose.
 * These scripts are solely intended to demonstrate techniques for accomplishing common tasks.
 * Additional script logic and error-handling may need to be added to achieve the desired results in your specific environment.
 *
 * It is up to the user to verify that his intended use of the offered automation functionality is compliant with any third party license agreement and/or other
 */

function main(inputs, outputFolder, params)
{
    for (i=0;i<inputs.length;i++)
    {
        var fileRef = new File(inputs[i]);
        var docRef = app.open(fileRef);

        app.doAction(params[0], params[1]);

        outputFile = new File(outputFolder + "/" + fileRef.name);
        jpgSaveOptions = new JPEGSaveOptions ();
        jpgSaveOptions.embedColorProfile = true;
        jpgSaveOptions.formatOptions = FormatOptions.STANDARDBASELINE;
        jpgSaveOptions.matte = MatteType.NONE;
        jpgSaveOptions.quality = 1;
        docRef.saveAs (outputFile, jpgSaveOptions, true, Extension.LOWERCASE);
        docRef.close(SaveOptions.DONOTSAVECHANGES);
    }
    return "OK"
}
    
```

3. Edit the settings of the **Run Script** task as shown below:

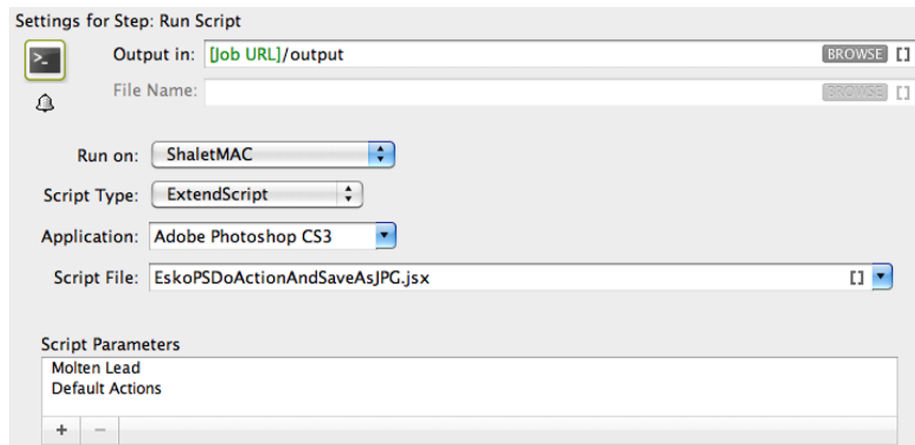

- a) **Run on:** is the name of the computer where your **Automation Engine ScriptRunner** is installed. The name in this example is ShaletMac. Learn more about configuring and naming a Script Runner in [Configuring Script Runner](#) on page 1920.
  - b) **Script Type:** choose ExtendScript.
  - c) **Script File:** choose EskoPSDoActionAndSaveasJPG.jsx.
  - d) **Script Parameters:** Add the name of your Photoshop **Action** name followed by your **Set**. In this example, Molten Lead; Default Actions
  - e) Save the task ticket.
4. Launch the task:
- a) Select a Photoshop file.
  - b) Right-click the file and browse for the ticket.
  - c) Click **Launch**.

You will see that while the script starts to run on the Automation Engine server, Photoshop opens, performs the actions, closes and continues the script. The result of this sample script is an adjusted JPEG file.

## 25.9. PowerShell Examples (macOS & Windows)

---

### My First PowerShell

This one only returns the message between `"`. See it appear in the task details (and log file).

```
Write-Host "Congratulations! Your script executed successfully"
```

### Write Local Time to File

This one writes the local time of the executing computer in the task details and also in a .txt file on the specified path.

```
Get-CimInstance -ClassName Win32_LocalTime | Out-File -FilePath C:\temp\localtime.txt
```

### Some specifics for an AE task

This one shows some specifics that help in the context of an AE task:

- `CmdletBinding` to capture the task's standard and custom parameters.
- `-split `:`` to split the list of input files (where more than one).
- Returning a task exit status: 0 = OK, 1 = warning, 2 = error .

```
[CmdletBinding()]
Param
(
    # Param1 help description
    [Parameter(Position=0)][string]$inputfiles,
    [Parameter(Position=1)][string]$outputFolder,
    [Parameter(Position=2)][string]$Parameter1,
    [Parameter(Position=3)][string]$Parameter2,
    [Parameter(Position=4)][string]$Parameter3
)

# checks if variables are declared
Set-StrictMode -Version 2

#begin of main program

#$hostname = get-content env:computername
$hostname = hostname

Write-Host "Starting script example.ps1 on: ", $hostname

#show PowerShell version
Write-Host "PowerShell version: ", $PSVersionTable.PSVersion

Get-Date

Write-Host "Received input files", $inputfiles

$inputArray = $inputfiles -split ':'

$retval = 0
Write-Host "Number of input files: " $inputArray.length
```

```
$outstring = ""

foreach ($inputfile in $inputArray)
{
    Write-Host "Handling input file: " $inputfile
    $lastWrite = Get-Item $inputfile | select LastWriteTime
    $outstring = $outstring + $inputfile + " " + $lastWrite + "`r`n"
}

Write-Host "Pstsmeter 1: " $Parameter1
Write-Host "Pstsmeter 2: " $Parameter2
Write-Host "Pstsmeter 3: " $Parameter3

$outputname = $hostname + ".lst"
try
{
    New-Item -Path $outputFolder -Name $outputname -ItemType "file" -Value $outstring -
    ErrorAction Stop
}
catch {
    Write-Output "An error occured while writing the output file"
    #Write-Output $_
    $errorMessage = $_.Exception.Message
    Write-Host $errorMessage

    $retval = 2
}
exit $retval
```

## 25.10. Scripting Samples

---

Click [this link](#) to download a PDF containing some samples of scripts.



## 26. How to ...?

### 26.1. How to Work with Technical Inks (Normalized PDF)



**Attention:** Technical inks (and varnish inks) are only used in Normalized PDF. This attribute is not present in PDF+ files.

The recommended way to work with technical inks is to follow these main rules:

- **Put objects in technical inks in top layers.**

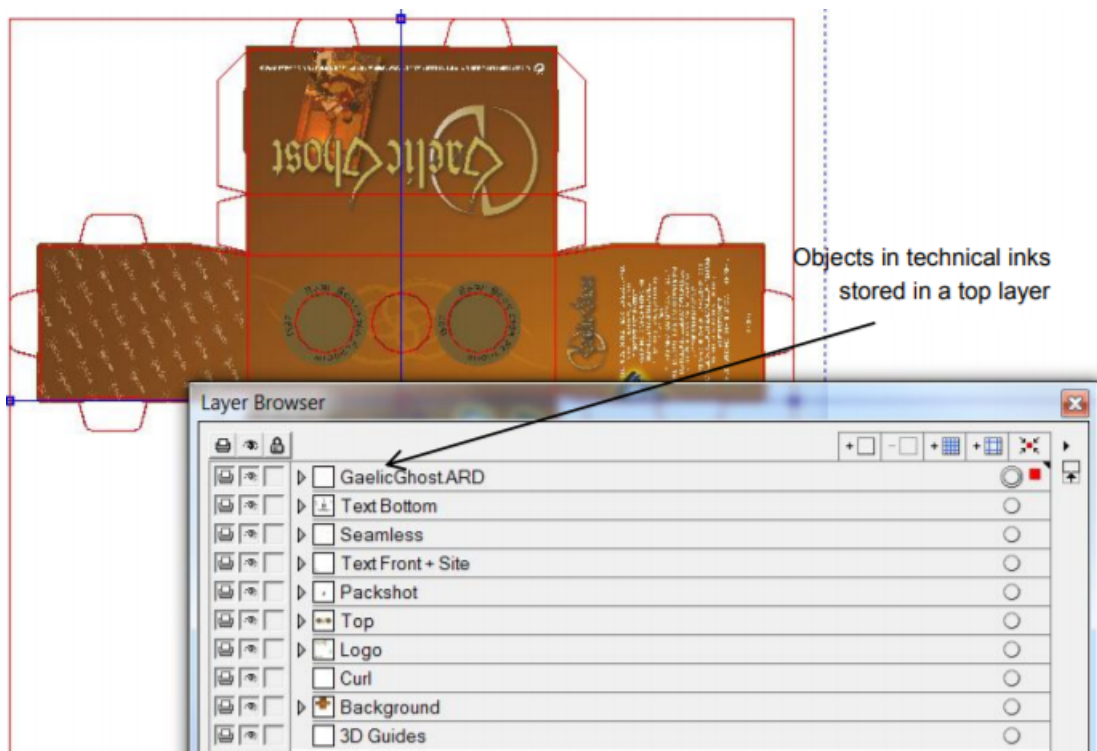

Objects colored with technical inks are stored in 1 or more layers at the top of the render stack. The advantage of this is that, when you use a PDF generated this way in an application capable of handling layers (PDF Optional Content Groups), you will also be able to view and print the design correctly with or without objects in technical inks by switching on or off the corresponding layers.

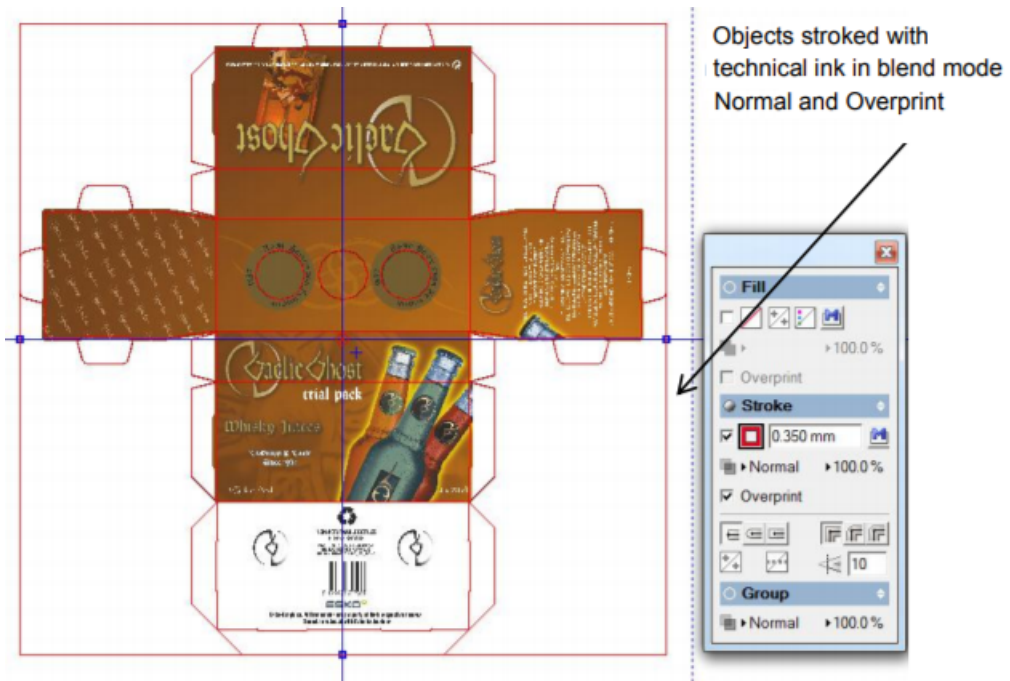

**Attention:** This only works as intended when the objects in technical inks do not influence the normal printing separations of the file. Also see below. Objects in technical inks do not influence printing separations.

It is best to avoid that objects in technical inks influence printing separations, for example knocking them out. Therefore it is best to stroke or fill objects with a spot color in blend mode **Normal** and switch on **Overprint**.

Do not use technical inks in opacity masks.

Do not put objects with printing inks on top of objects with technical inks in other blend modes (Hue, Saturation, Color, Luminosity, etc.).

- **Avoid using technical inks and normal printing inks in a same object.**
  - You can use the task [Optimize and Clean \(PSFix\)\(Classic\)](#) to detect any interaction between objects in technical inks and printing separations. Its auto correction feature can switch on overprint if the object was put in knock-out. Since overprint is an attribute of the object and not of an individual separation of an object, this will result in unintended changes of the printing separations.
- **Use a solid tint.**
  - It is recommended to color an object with 100% of a technical ink. Avoid using tints, shadings, etc.

## 26.2. Hybrid Press Workflow

---

### 26.2.1. Concept of Hybrid Printing

Packaging and labels are sometimes printed using a combination of printing methods: some of the separations are printed in flexo, a metallic separation is printed using screen printing, and some other data are added to the label using inkjet printing.

In the label industry it is common to see all these printing methods integrated in a single press. These presses are often referred to as “combi-presses” or “hybrid presses”.

These pages describe how to handle designs that will be produced using several printing methods. The described workflow is valid both when using integrated hybrid presses and when using multiple presses of different types.

### 26.2.2. What is the Problem?

Working with hybrid presses poses specific challenges in the prepress phase.

You may receive a file that contains separations for different printing methods. In your prepress and output workflow, some of these separations may need to be treated differently than others. Some typical cases:

- Trapping parameters may need to be different per printing method
- Printing marks may need to be different per printing method
- Plate distortion parameters may be needed for one printing method (typically flexo) but not for other separations.

### 26.2.3. How to define the Printing Method of a Separation?

The **Printing Method** of a separation can be set by an operator in an Esko editor (ArtPro, DeskPack, PackEdge, Plato) or by a setting in a Normalize task. The there set printing methods are stored in the ArtPro file or Normalized PDF(PLA) file but also in the PDFs that you export from those files (using the editor or a task).

#### **Predefined list of printing methods**

These editors and tasks offer a predefined set of printing methods. It is recommended to use these whenever possible as this will guarantee interoperability of the generated files between sites and even countries. The values are stored in the PDF with proper localization handling.

You can also enter custom values. In this case these custom values need to be agreed between sender and receivers so that printing methods can be recognized consistently by receivers. This is not obvious in a global economy with senders and receivers in different parts of the world.

### Assigning a Printing Method manually in ArtPro, PackEdge or Plato

Figure 1: The Separations dialog in ArtPro

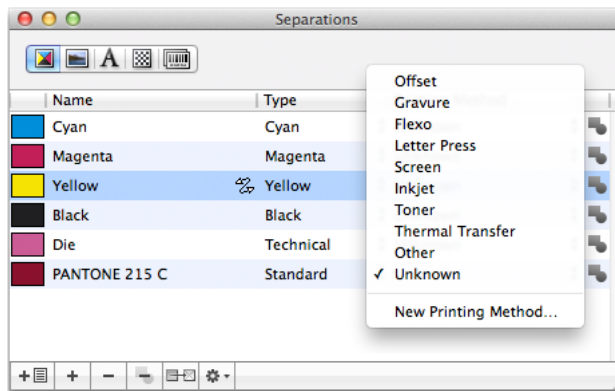
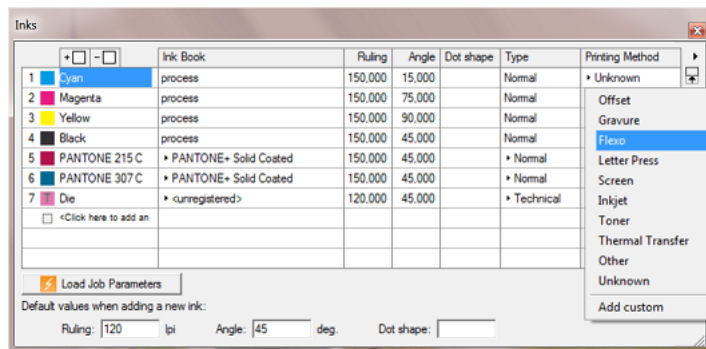
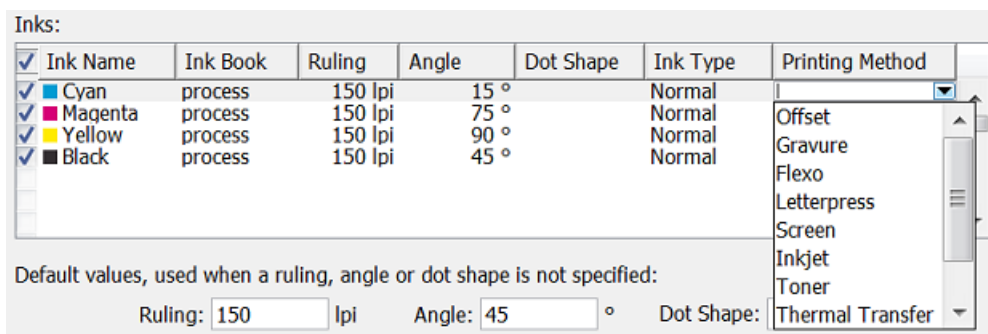

Figure 2: The Inks dialog in PackEdge and Plato



### Assigning a Printing method in Classic 'Normalize' Tasks

The *Normalize PDF file task*, the *Normalize PostScript, PDF, Illustrator file task* and the *Normalize Tiff/IT file task* offer a dedicated column in their tab 'Inks':



### Automating the Assignment of a Printing Method

Follow these steps to automate the assignment of printing methods:

1. You can use the Pilot and set these values manually in the **Inks** tab of the **Job Setup** dialog. These values can also be set during *automatic job creation by an MIS system, via JDF or XML*.

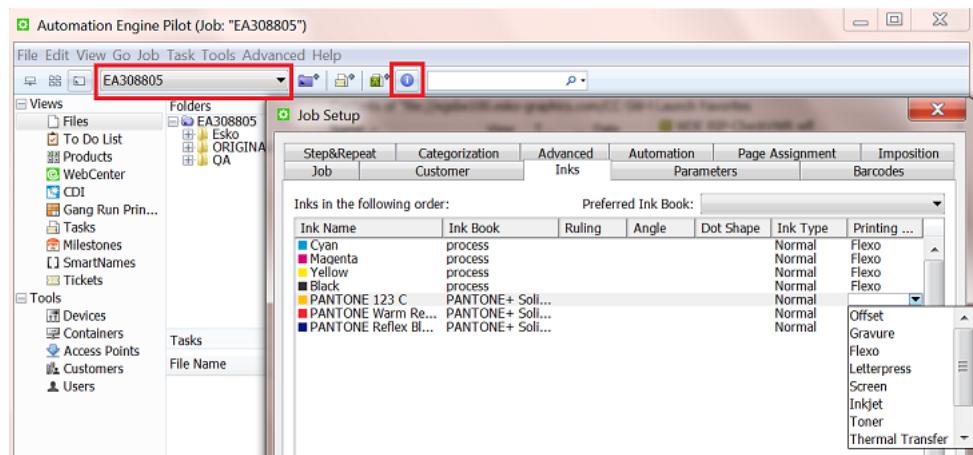

2. You can then use the [Check Job Parameters](#) task to apply the values defined in the job setup to PDFs and Normalized PDFs. Mind that you will need to enable the **Auto Correct** option for **Inks**:

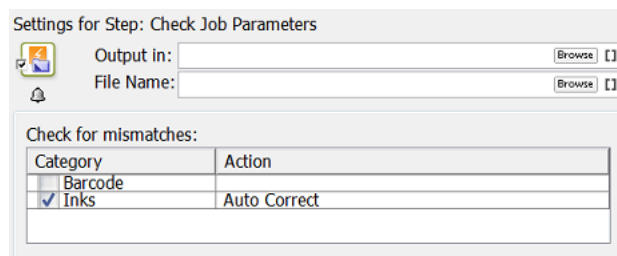

### 26.2.4. How are the Printing Methods stored in the PDF?

The printing method of each separation is stored in the XMP of the PDF (Normalized or native PDF). This makes this information also accessible for third-party applications.

An example:

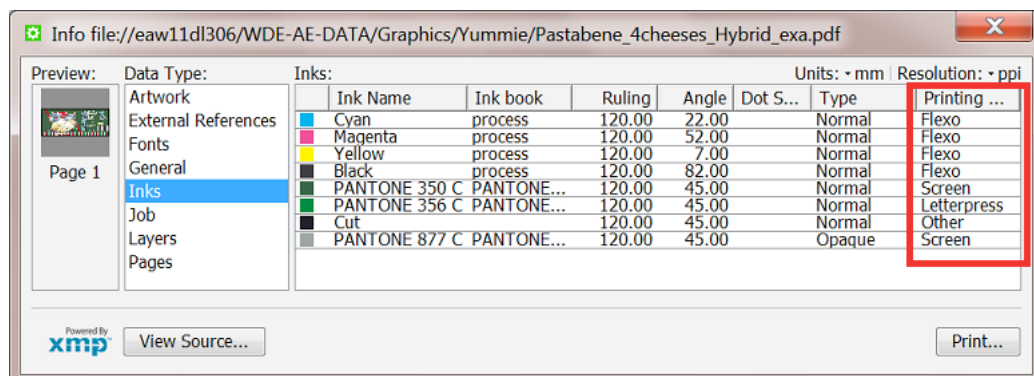

### 26.2.5. How to Differentiate the Processing of Separations for Different Printing Methods?

The *Extract Inks(Classic)* task in Automation Engine was created just to enable workflows handling these different requirements for different printing methods.

Here is an example workflow:

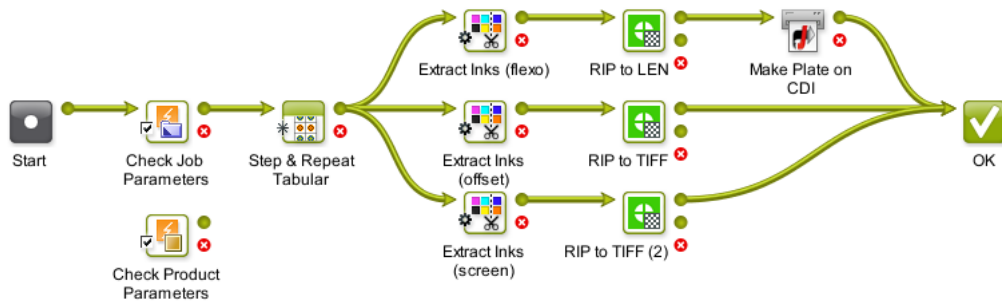

1. In the first step, the **Check Job Parameters** task sets printing methods for the different separations in the incoming PDF. In case you use the Products tool, you could use the **Check Product Parameters** task in stead.
2. Then, a **Step & Repeat** task creates a layout.



**Note:** When the task also applies a SmartMarks set, you can choose to already set the marks in inks of a selected printing method. See this example of defining inks of a gradation strip:

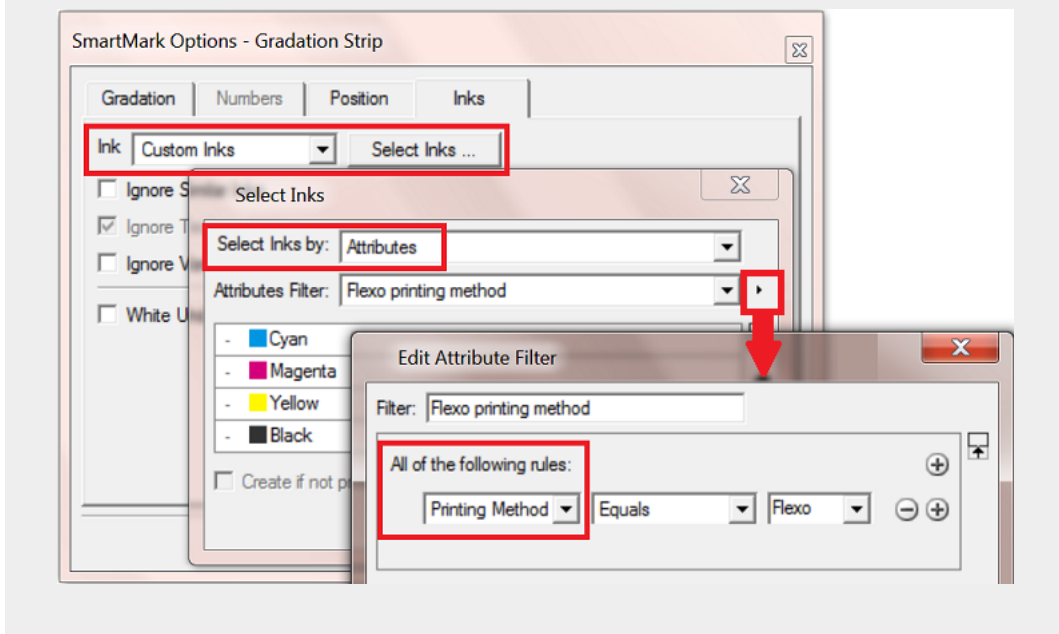

3. The *Extract Inks (Classic)* task then creates 3 different files only containing the inks of the selected printing method:
  - The top branch of the workflow extracts the flexo separations.

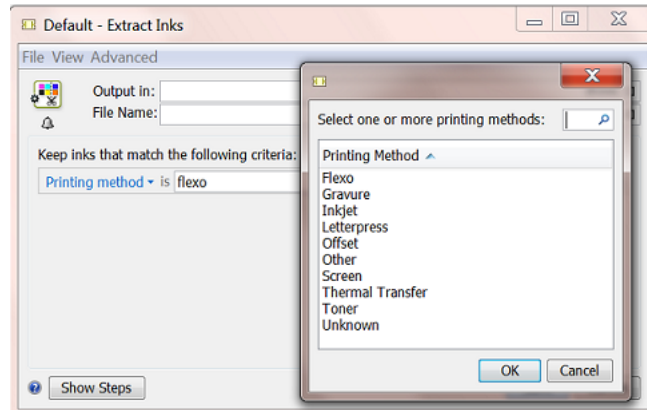

- The middle branch extracts offset separations.
  - The bottom branch extracts separations for screen printing.
4. Finally, each branch sends the PDF(PLA) with only the selected separations to a RIP with specific settings for that same printing method.

## 26.3. Integrating with Nexus (outdated)

---

Integrating with Nexus is based on a task that is outdated

Learn more in [the chapter "How to...?" of the manual of AE 16.1](#). It contains information on this setup and also the page describing the 'Send to Nexus' task.

## 26.4. Integrating with Odystar (outdated)

---

Integrating with Odystar is based on a task that is outdated. Learn more in [Send to Odystar \(outdated\)](#).

# 27. Pre-Install IT Requirements

---

## 27.1. Introduction

---

This document describes the information needed to prepare and facilitate the installation of an Automation Engine. It also answers typical IT related questions.

General system requirements for the involved computers can be found on [this page](#).



**Note:** This document mentions components and features that are commercially optional.



**Note:** The term 'CP' is often used as abbreviation for 'Commercial Print' (page workflows).

There are two sections in this document :

1. Technical details of an Automation Engine setup.
2. Guidelines and good practices in setting up an Automation Engine environment.

## 27.2. Technical Details

---

### 27.2.1. Automation Engine in its environment

#### Components Glossary

Component	Description
Automation Engine Master server	Main server where all clients are connecting to. This server manages the Jobs, tasks and other databases. This server also executes the actual server tasks. This master server is set up on premises or at a hosting data center and so available as an AE SaaS.
Automation Engine Assistant server	Assistant server that can execute tasks to take away load from the Master server.
Application server	Component serving the Automation Engine page workflow tools (the Pilot modes for commercial print). It is also used by some tools in the Layout module. Note: Since AE v20, the AE Viewer no



Database server	longer uses this server but uses its own Viewer server.
Client	Server where the databases are located. Typically this component is found on the Automation Engine Master server.
Imaging Engine	A client workstation is connecting to the Automation Engine Master server via the Pilot or Shuttle application or via a browser client. Editors can also connect to the server (Esko editors or Adobe Illustrator).
FlexRip	Esko RIP component built into Automation Engine (commercial option). Offers tasks to generate digital files for proofs and/or plates.
WebCenter	Separate Esko RIP product that the Automation Engine Master connects to. FlexRip/FlexProof was the predecessor of Imaging Engine.
File server	Esko's online collaboration tool.
Mail server	Where the actual graphics data is. Automation Engine can work with all files in data shares that you configured to be Automation Engine 'Containers'.
	Your mail server that can be used by Automation Engine to send out e-mails.

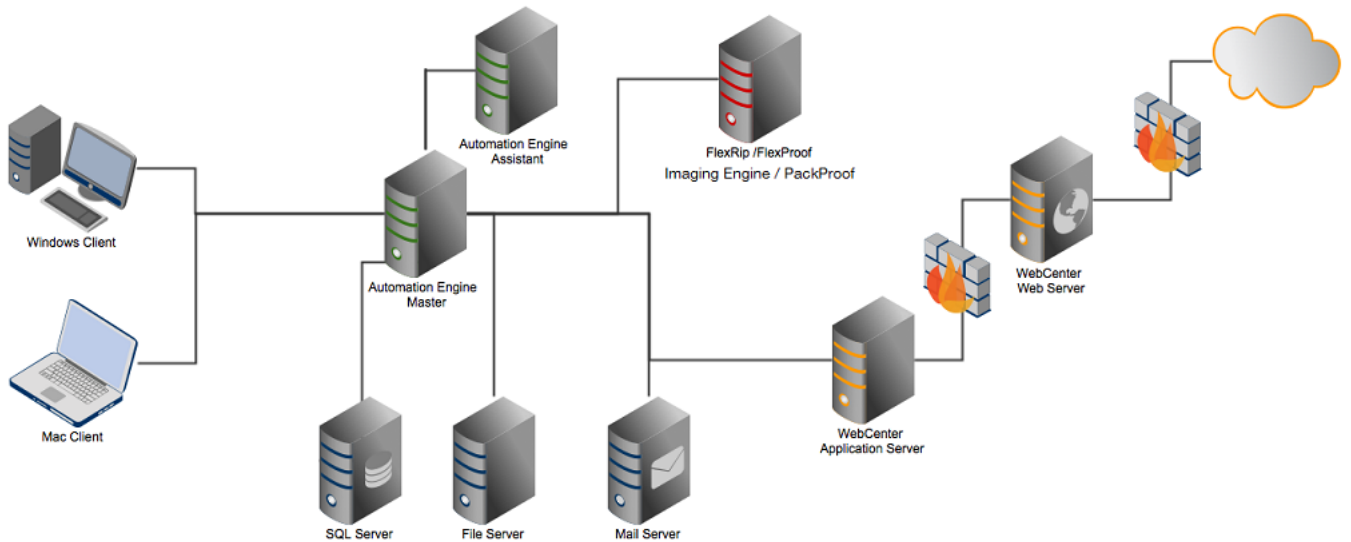

### 27.2.2. Automation Engine installation

### Automation Engine System Account

Automation Engine needs a **System Account** user to run its service and to connect to other network components.

The Automation Engine **System Account** must meet following requirements on the Automation Engine Master server computer:

- should be a member of the group **Administrators**
- should have the right "**Log on as Batch**"
- should have the right "**Log on as Service**".

A first installation of Automation will request you to first create this **System Account**. You will be asked to define its user name and password.

Learn more in [System Account page in the Server Admin web page](#).

### Services

An installation of Automation Engine will install these services:

Service name	Service running under	Purpose
BGMD	Automation Engine System Account	Automation Engine's main service
EG STATION INFORMATION SERVICE	Local System User	System info collection service
AEWebApps	Automation Engine System Account	Web server for the Server Admin web pages and client updates
FLEXIm License Manager	Local System User	License manager
FLEXnet licensing service	Local System User	License manager
MSSQLSERVER	Network Service	Default database server
MSSQLServerADHelper	Network Service	SQL Server Active Directory Helper
SQLWriter	Network Service	SQL Server VSS Writer
SQLBrowser	Network Service	SQL Server Browser
EGTunnelServer	Automation Engine System Account	Web server for remote access to Automation Engine

### Shares

These shares are created during the installation of Automation Engine:

Sharename	Purpose	Access
AutomationEngineImgFolder	Temporary folder for image data	server only
AutomationEngineLogging	Automation Engine log files	server only

AutomationEngineTmpFolder	Temporary folder for Automation Engine tasks	server only
bg_data_cms_v010	Central resources - Color management data	server and clients
bg_data_custom_v010	Central resources - Automation Engine presets	server and clients
bg_data_dgc_v010	Central resources - Dot gain curves	server and clients
bg_data_fonts_v040	Central resources - Fonts data	server and clients
bg_data_ipldata_v010	Central resources - CIP3/ Inkplanner presets	server and clients
bg_data_marks_v010	Central resources - SmartMarks sets	server and clients
bg_data_screens_v020	Central resource - Screens for Imaging Engine	server and Imaging Engine RIPs.
bg_data_system_v010	Central resources - License configuration	server and clients
DeskPackContainer	Container for temporary DeskPack files	server and clients
ExampleJobContainer	Default data container created at first install	server and clients
FastRipTask	FlexRip temporary folder	server and clients
Impose	FastImpose templates, marks and defaults	server and clients
PitStop	Enfocus PitStop templates and configuration data	server and clients



**Note:** The access right of these shares is set to **Read/Write for 'Everyone'**.



**Note:** In case you would like to restrict permissions on these shares, be aware that these permissions affect the access by desktop applications like PackEdge, ArtPro Action List Editor, Curve Pilot, FlexRip, etc. Note that they do not affect access to the Pilot. The Windows users *used to start up* these desktop applications, as well as the Windows users *used to mount* shares needed for Mac applications, must have read and write access to those shares.

Additionally, the [Automation Engine system account](#) must have read and write access to these shares as well.

### Installation Folder

Automation Engine is by default installed on the root drive in a folder called `EsKo`.

Automation Engine can not be installed in the **Program Files** or **Program Files (x86)** folder.

Every Automation Engine installation will create and use a temporary folder in the Esko folder (BG\_TMP).



**Tip:** It is good practice to defer that folder to a drive other than the system drive. Learn more in the [Installation Guide](#) on page 1982.

## 27.2.3. Network Details

### Network Configuration

Automation Engine requires TCP and IPv4 to work.



**Note:** IPv6 is not supported.

You need to configure DNS correctly. Links to other networks should be configured using host names, not IP addresses.

If a DNS and/or proxy server is used, make sure all components in the environment (Automation Engine server(s), Automation Engine client, Proxy Server) are able to do an `nslookup on hostname` of all other components.



**Attention:** After installation of the Automation Engine software, the host name of that server can not be changed.

### Ports

#### Ports used by Automation Engine and the client software:

- TCP:
  - 8000-9000 for BGMD and other Automation Engine servers
  - 1098 RMI port for the Automation Engine Application Server
  - 1099 for the JNDI Naming Service for the Automation Engine Application Server
  - 1433 for the SQL server (default installation)
  - 1538 for the AAServer, the server handling user management and permissions (Authentication and Authorization)
  - 4401 for the Automation Engine JDF Server (service port)
  - 4420 for JMF communication with Imaging Engine.
  - 4444 the RMI Object for the Automation Engine Application Server
  - 4445 the Transaction Manager for the Automation Engine Application Server
  - 5182 for ShuttleServer, unless configured otherwise
  - 5544 the Automation Engine CDID server that communicates with a CDI's DFS application
  - 27000 for the License Manager service
  - 27100 and a dynamic port for the Station Information Service
- HTTP:
  - 9000 for the web server port of the browser client workspaces
  - 9999 for the Server Admin web pages (egwebapps.exe)

- 9897 for the Server Config web pages
- 18560 for the Automation Engine Viewer
- 8080 for the Automation Engine Application Server
- 4411 for the Automation Engine JDFServer (JMF)
- 4412 for the Automation Engine Frip2JDF Server, which communicates with the DFS/PlatePrep and Grapholas software on CDI's
- 4415 for the Automation Engine Web Service (ElemServer)(unless configured otherwise)
- 44110 for the JMF port of the task Interact using JDF/JMF.
- 44111 for the JMF port of the Devices server.
- 443 for all tunnelserver communication with Automation Engine (used for signing in with Okta and used in a SaaS setup)

Connection with clients:

- The server sometimes relies on ephemeral ports, for example for uploading files in Pilot. These ports are picked randomly between 49152 and 65535.

### Ports used by an Automation Engine Agent

- TCP:
  - 5544 the CDID server that communicates with a CDI's DFS application
- HTTP:
  - 44122 the web service of the Agent
  - 44211 the JDF service of the Agent

### LAN/WAN Network Performance

Automation Engine client-server connection requires decent network performance. This is also true for the server's access to remote containers and/or devices.

Latency simulations in a lab environment show that:

- With delays below 20ms, client (Pilot) performance or access to remote containers and/or devices is optimal.
- With delays till 50ms, client performance or access to remote containers and/or devices is relatively acceptable.
- With delays around 100ms (and higher), client performance or access to remote containers and/or devices is poor to unacceptable.

Therefore Automation Engine is not suited to run in a WAN environment.



**Note:** Automation Engine is also available as a SaaS solution. Learn more in [AE SaaS: When your AE is in a Data Center](#) on page 1633.

### 27.2.4. Database server

Installing Automation Engine also automatically installs an **SQL Express** database engine. However, for scaling and performance reasons, one can choose to use a **Full SQL Server**. Learn more in [Using a Full SQL Server](#) on page 1977.

## Installation Details

Mandatory components:

- SQL Server Database Engine
- Replication and Fulltext components

Mandatory installation parameters:

- Collation settings: Use Windows' defaults (supported from Automation Engine 14.0.1 on)
- Security Mode: SQL
- TCP protocol for the SQL Server service: enabled



**Note:** These are the installation parameters used to install the default MSSQL Express server:

```
/ACTION=INSTALL
/FEATURES=SQLEngine
/BROWSERSVCSTARTUPTYPE=Automatic
/SQLSVCSTARTUPTYPE=Automatic
/SQLSVCACCOUNT="NT AUTHORITY\SYSTEM"
/SQLSYSADMINACCOUNTS="BUILTIN\ADMINISTRATORS"
/IACCEPTSQLSERVERLICENSETERMS=1
/INSTANCENAME=<instancename> of MSSQLSERVER for unnamed instance
/SECURITYMODE=SQL
/SAPWD=<default password>
/TCPENABLED=1
```

## Configuration details

Automation Engine requires 4 databases to run:

- BSJobs
- FastLane\_TM
- FastLane
- fasttrack



**Note:** The terms *BS* and *FastLane* refer to names of old Esko products that Automation Engine's server framework originates from.

To access and modify these databases, Automation Engine needs a user who can:

- Log in to the Database server
- Database roles:
  - db\_owner: Members have full access.
  - db\_accessadmin: Members can manage Windows groups and SQL Server logins.
  - db\_datareader: Members can read all data.
  - db\_datawriter: Members can add, delete, or modify data in the tables.
  - db\_ddladmin: Members can run dynamic-link library (DLL) statements.
  - db\_securityadmin: Members can modify role membership and manage permissions.
  - db\_backupoperator: Members can back up the database.

## Oracle as Database Server for the Application Server component



**Attention:** From Automation Engine 18 on, this support for Oracle was set to 'Soon Outdated'. This means that, in a next major version, support for this database server will be removed.

An Oracle database server can be used to run the Automation Engine Application Server.

Using Oracle will increase performance of the Pilot modes **Pages, Proofs** and **Plates**. These modes are only used in a production workflow for books and magazines.

Following database server versions are supported:

- Oracle 10g Standard Edition, Enterprise Edition
- Oracle 11g Standard Edition, Enterprise Edition



**Attention:** Using Oracle as a database server for `BSJobs`, `FastLane_TM` and `FastLane` is not supported.

## 27.2.5. File Server

### File Server OS Types

All Esko applications running on Windows OS can use data that is available on network shares. For Automation Engine to perform according to expectations, these shares need to be on NTFS volumes on Windows file servers.

As only Windows file servers are supported, Mac OS X or Unix/Linux (CIFS/SMB or NFS) data servers for example are not supported (including many Network Attached Storage units).

### Supported Access Protocols

Esko does not support file server access over protocols other than "Windows File Sharing".

### File Server Access

The Automation Engine System Account must have read and write access on the shares. Learn more in [Automation Engine System Account](#) on page 1964.

## 27.2.6. Mail Server

Automation Engine can use your e-mail server or account to send e-mails.

Learn more on configuring the use of an e-mail server in [E-Mail Configuration](#) on page 194.

## 27.2.7. Users and Groups

## Old and New User Model – Before and Since v20

### BEFORE v20. The OLD User Model

Before v20, users created by Automation Engine were always Windows users on the Automation Engine server computer. You could use a tool in Automation Engine to add them, but they were actually created on the Windows OS of the server.

- **Local Windows user.** This is a user whose user name and encrypted password are stored on the computer itself.
- **Domain Windows user.** This is a user whose user name and password are stored on a domain controller rather than the computer the user is logging in to. Your IT staff manually had to add those domain users to the Windows groups BGUSERS or BGADMIN.

As security requirements became more important, Automation Engine had to step away from this model.

Learn more on the page [Migrating from the Old User Model to the New one](#) on page 1971.

### SINCE v20. The NEW User Model

As introduced in the page about [Authentication and Authorization](#), user accounts that you can sign in with to Automation Engine 20 and later can come from several [Identity Providers](#) (IdPs).

Creating users using an Automation Engine tool no longer creates Windows users.

Since v20, Automation Engine accounts can be provided:

- by Automation Engine itself: These are called **Internal** users.
- by the Windows user subsystem: These Windows users exist after an upgrade (corresponding to both local and domain Windows users from the old user model), or can get created when a domain Windows user signs in for the first time.
- by an external IdP:
  - **LDAP.**  
Only Microsoft Active Directory on a Windows Domain Controller is supported as an external IdP.  
If you were using domain users in the old model, we advise you to change to LDAP in the new model.



**Important:** An LDAP user only appears in the Users View after its first successful sign-in.

- Support for more providers is in progress.

### Configuration of the User Model in Automation Engine

You can disable specific identity providers and configure the ones you want.

This is done in a special version of the Server Admin web page that only runs locally on the AE server computer itself.

Learn more in the chapter on AE Server management, in [The AE Server CONFIG web page](#) on page 1997.



## Migrating from the Old User Model to the New one

### Automatic Migration to the New User Model during an Upgrade to v20

When upgrading an Automation Engine to version 20.0 or higher,

- All existing Automation Engine users, both local and domain Windows users, are converted to the new user model and categorized as users of the provider 'Windows'. See the column **Provider** in the Users view.
- You can use these migrated users in v20, but, in a next major version, Automation Engine will no longer support users of the provider Windows.



**Attention:** We strongly advise to prepare to further migrate users from the legacy provider Windows to the modern Internal or LDAP provider. Learn about the dedicated tool to [migrate users](#).

- The migrated users keep all their attributes, including its e-mail, Access Rights, Views, Smart Views, Favorites, etc.
- The migrated users can sign in with their same user name and password.
- The former user properties Name and Domain are now combined into the single new User Name property in which the former name and domain are separated by the @ sign.
  - New AE users with provider Windows that map to local Windows users (on the AE master server) will always have a user name that ends in "@<server>", with <server> being the host name of the AE master.
  - As before, when a user's domain is not the local host, he needs to add the domain name to his user name, for example `george23@bigcompany.com`.
- The upgrade also migrates the two predefined Windows user groups BGADMIN and BGUSERS to the v20 concept of groups, where they still contain the same users.
  - Members of the group BGADMIN are, as before v20, granted the right to administer the server.
- The upgrade also creates as many new AE roles as there were custom groups as you could see in the Pilot of the older version (**Setup views > Users view > tab Groups**). Their names and predefined Access Rights are kept, as these new AE roles serve the same purpose as the old custom groups. The imported AE users that previously belonged to such an old custom group, are now attributed the corresponding new AE role.
- Automation Engine continues to need a **System Account** user to start and run the main server software (the service BGMD) and to enable connectivity to other network components. This account (by default the user BGSYSTEM) still needs to be a Windows user, for example to grant client users the access to 'Explore' Containers (access to data shares). Learn more in [Automation Engine System Account](#) on page 1964.

### When, on v20, Restoring a Backup from an Older Version

- All users in the backup (these are all users that at least once actively logged on to the older version server where the backup is taken from) are 'imported' at restore time into the new user model of AE 20.0 as new AE users with provider Windows.
- The behavior after restoring is identical to how it was before v20. For example, only the user related information about Favorites is restored, which implies that not all functionality that in one way or another relates to users and/or relates to information about them will behave as on the system the backup was taken from).
- The behavior about local or domain Windows users after the restoring is the same as after an upgrade to v20 (see above).

### Migrating Users Yourself to another Provider

The [Users](#) view offers a dedicated tool to manually migrate users. Learn more in [Migrating Users](#) on page 1972.

### Migrating Users

#### Migrating Windows users to Internal or LDAP users

- In the Users view, select one or more users from the provider Windows.

When selecting multiple Windows users, they must all belong to the same domain. The domain of a user is the part of the user name after the (last) "@" character.



**Attention:** Users that were not visible in the Users View at the moment of selection will not be taken into the selection. An example: If you have 200 Windows users belonging to the same domain, you should not select all of them and migrate all 200 in one go. Only the users visible in the view at the time of selection will belong to the selection (maximum +- 50).

- Right-click your selection and choose **Migrate Users...**

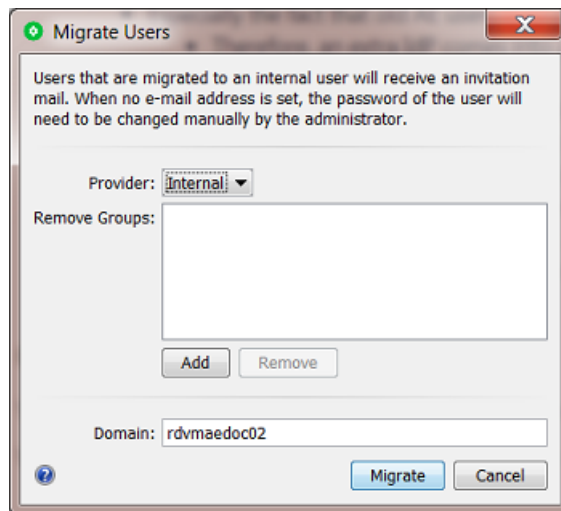

- Provider:** Select the new provider:
  - Internal:**
    - Windows user passwords cannot just be taken over. That is why users that are migrated to an internal user will receive an e-mail that invites them to choose a new password. When no e-mail address was set, the password of the user will need to be changed manually by the administrator.
    - All other user related properties are kept (Full Name, E-mail Address, Description).
    - Note that migrating a user will not remove that local Windows user at the Windows OS level, nor will it remove it from the BGUSERS or BGADMIN local Windows group it belongs to. Still it will no longer be possible to use this local Windows user's credentials to gain access to Automation Engine.

- **LDAP:**
- **Remove Groups:** When migrating users, it is possible to select some groups from which the selected users should be removed.  
This could be the moment to remove them from the old groups BGUSERS and BGADMIN that were migrated during the upgrade to v20.
- **Domain:** Leave this field empty to strip of the domain name from the user name. Or type in a new domain name for that user. Be aware of these consequences:
  - When migrating to the **Internal** provider:
    - **Leaving the domain part as it was** will always require the full name to be used at sign in time (whereas, before migrating the user, the name without the domain part may have been sufficient).  
The benefit however is that this choice ensures that all user related info is kept (settings for Views, Access Rights, Red Alerts as well as Preferences and Favorites) and user related behavior remains identical (for example user presets in Access Points, To-dos, Tickets, SmartName resolving, Notification e-mails).
    - **Clearing the domain part** makes it easier at sign-in time, but comes with the limitation that only the user related info about Favorites can be kept. This choice may also influence the user related behavior.
    - **Changing the domain part** into another domain name is possible, but probably does not make much sense. It also comes with the same consequences as clearing the domain part.
  - When migrating to the **LDAP** provider:
    - **Leaving the domain part** as it was keeps all user related info (settings for Views, Access Rights, Red Alerts as well as Preferences and Favorites) and user related behavior remains identical (for example user presets in Access Points, To-dos, Tickets, SmartName resolving, Notification e-mails).
    - **Changing the domain part** into another domain name could make sense if that is required to map the (domain) Windows provider identities to LDAP provider ones. This however comes with the limitation that only the user related info about Favorites can be kept. Also, the user related behavior may be influenced by this choice as well.
    - **Clearing the domain part** makes no sense.
- Click **Migrate**. A dialog will provide feedback.

### FAQs about the User Model

- **Q: Does Automation Engine support Single Sign-On?**
  - A: The Automation Engine client software does not yet offer any implementation for [Single Sign-On](#)(SSO).
- **Q: What if the password of the only Admin user can't be found?**
  - A:

1. When you have access to that user's mailbox, try the "Forgot password?" tool to set a new password.
2. When you can't use this tool, contact Esko Support.



**Attention:** For security reasons, user information is kept out of Automation Engine's SQL databases.

• **Q: What happens when I restore a backup that contains pre-v20 users?**

- A: For example: you have a new installation of v20 and restore a backup onto it that was made of a v18.1.

The v18.1 users in that backup will be added to the new v20 as they were: They will appear in the Users view, with provider Windows.

So basically the result is the same as if you would have upgraded on that server from v18.1 to v20.

• **Q: Why can't I see a specific LDAP user in the list of users in the Users View?**

- An LDAP user only appears in this list after its first successful sign-in.

## User and Groups in the Old User Model

### Windows Users & Windows User Groups

Before v20, users in Automation Engine always mapped to Windows users Automation Engine *master* server computer.

These Windows users were organized in two local Windows groups on that Automation Engine server:

- **BGUSERS:** normal users
- **BGADMIN:** administrator users



**Attention:** Automation Engine user groups do **not** correspond to Windows user groups.

Before v20, in the old user model, there was no tool in the Pilot to create user groups. All had to be done via Windows tools.

Before v20, when you used the tool in the Pilot to create a new user, a local Windows user with the same name was created on the Automation Engine server computer.

### Windows Domain Users

You could also add existing Windows "domain users" to become Automation Engine users. This is still valid in the new user model since v20.

If you want to use domain users, your IT staff needs to assign these domain users to either the BGUSERS or the BGADMIN local Windows group.

To use domain users in Automation Engine, this requires that the Automation Engine System Account can retrieve user info from the Active Directory.

Learn more in [Automation Engine System Account](#) on page 1964.



**Attention:** Automation Engine does not offer support for Domain Groups.

### The System Account

The Automation Engine **System Account** is a special user that runs the Automation Engine services and connects to other network components.

The default System Account is the user **BGSYSTEM**.

You can change this to another account by using [the System Account page in the Server Admin web page](#).

## 27.2.8. The Automation Engine Pilot

### Java

On Windows and MacOS, a Java Runtime Environment (JRE version 1.8) is distributed with the Pilot client application. You do not need to install Java on the client computer yourself.

## 27.2.9. The Automation Engine Web Service

### Web server software that Automation Engine web tools are hosted on

Automation Engine tool	is hosted on
Automation Web Services (used by the Web Service Access Points)	Jetty
Automation Engine Server Admin web page	Jetty

### FAQs

- **Can we apply a certificate to the Automation Engine Server Admin web page (because out of the box there is no certification assigned at all)?**
  - A: Yes. Learn more on the page [Configuring and Checking the Automation Engine Web Service](#) on page 1795.
- **What is Automation Engine's dependency on IIS (Internet Information Services from Microsoft)?**
  - A: None.

## 27.3. General Guidelines

---

### 27.3.1. Scalability and Performance (AE server on-premises)



**Attention:** Most of below information relates to an Automation Engine setup on-premises, and not an AE SaaS setup.

## Adding an Automation Engine Assistant

Adding Assistants spreads the task load over more computers.

Per Master server group, independent of the number of Assistants in this group, the maximum of processing channels is 16.

When, even with 16 processing channels, queues keep getting longer and tasks are still not executed fast enough, then you should consider [adding an extra Master server \(group\)](#).

## Adding an Assistant to Increase Throughput

Automation Engine comes with a built-in limit on the amount of concurrent tasks (tasks that are processed simultaneously). The number of concurrent tasks that can be processed depends on the licenses purchased. When you evaluate and define the amount of needed concurrent tasks you should take into account the number of processed files and the number of task run on these files over a certain period.

The amount of concurrent tasks needs to be in line with the capacity (RAM/CPU) of the Automation Engine server. More concurrent tasks will increase the load on the system. If the capacity of the Automation Engine server has reached its limits, it can be increased by adding one or more Assistant servers. One Automation Engine server will then take the role of Master, the other(s) will take the role of Assistant. The Master will monitor its own load and the load of the assistants to decide on which server a task should be executed.

## Adding an Assistant for Redundancy

An Automation Engine Assistant is not an out of the box fail safe solution.

However, it could be used in a fail safe scenario. In case the Master breaks down, an Automation Engine server in an Assistant role can be promoted to become the Master server. A full backup package of the Master (Configuration, Resources, Databases) can then be restored on the Assistant to rebuild the initial configuration. Note: the backup package of the Master generated by the scheduled backup procedure of Automation Engine can be automatically copied to the Assistant.

Fail safe solutions based on proper backup tools or on snapshots of virtual images are a valid alternative, and might be seen as a more effective solution.

## Adding an Assistant versus Adding an extra Master

When throughput needs to be increased, adding an Assistant is sometimes not the best option. When the production/organization can be split into logical components, it could make sense to add an extra Master.

Also in a group of a Master and his Assistants there is only 1 'CPU queue'. Each time an entry of this queue can be processed (= when a processing channel becomes available), the best suited computer in that group is chosen to execute this task. The best suited computer is the one with the least load on CPU/memory.



**Tip:** Learn more on Master and Assistant setups in the chapter [Automation Engine Server Management](#) on page 1997, in its section on [Server Roles](#) on page 2012.

## Redirecting Central Resources

Following shares are considered as central resources:

- bg\_data\_cms\_v010
- bg\_data\_custom\_v010
- bg\_data\_dgc\_v010
- bg\_data\_fonts\_v040
- bg\_data\_ipldata\_v010
- bg\_data\_marks\_v010
- bg\_data\_screens\_v020

It is allowed to redirect these resources to a central file server. Valid reasons for doing this are:

- Access: these shares also need to be accessible for other applications/servers than Automation Engine (PackEdge, ArtPro, FlexRip,...)
- Backup strategy: these shares contain critical files such as color profiles, marks, curves etc. Remember that these shares are also included in Automation Engine's scheduled [backup](#).



**Note:** Esko recommends keeping the resources on the Automation Engine server to avoid extra network traffic.

## Using a Full SQL Server

### Express edition versus Full SQL Server

Automation Engine requires a working DBMS (Database Management System) for its proper operation and "persistent storage".

Microsoft's SQL Server Express Edition is delivered and installed together with Automation Engine. Automation Engine is configured to work with this SQL Server as default DBMS in this out-of-the-box setup. The installation creates new and empty databases and users.

The SQL Server Express Edition software has these limitations :

- Database sizes are limited to 10 GB.
- The service named `SQLServer` will only use 1 CPU and will restrict its memory usage to 1 GB.

In many cases, the SQL Server Express Edition will be sufficient. However, from a certain load or performance expectation onwards, it is highly recommended to upgrade your Express edition to a "full" SQL Server.

The next pages give recommendations as to when the DBMS for an Automation Engine installation should be upgraded from an Express Edition to a full SQL Server.

### Database Size Limitations

SQL Server Express Edition, which is delivered along with Automation Engine, has a size limitation of 10 GB per database. However, you can scale up to a full version of SQL Server to increase the size limit to the disk size.

Given that Automation Engine has three main databases (or four, depending on the configuration), consider the following points:

- **Jobs database:** Automation Engine does not function as an archiving system. To keep the Jobs database size under the limits, we recommend:
  - only keep a Job online for its lifetime. The *concept of a Job* is temporary by nature. Jobs, after a while, are done. If you have many re-prints of products, then consider using the Products tool as well (which does use the same database as Jobs).
  - archiving unused Jobs and Products.



**Note:** Theoretical limits regarding the number of Jobs and Products exceed the practical Express Edition server demands (<50.000 Jobs / <250.000 Products) considerably.

- **Task Monitor database:** To keep the size of the Task Monitor database under limits, we recommend:
  - setting up adequate **Task Clean Up rules**. Clean up can be removing them or it can be moving them to a separate task-archive: the **Task History database**.



**Note:** The theoretical limit on the number of tasks in the Task Monitor in terms of size (>100.000 tasks) is overruled by what the Express Edition server can handle in terms of performance (<100.000 tasks).

- **Task History database:** When you do not want to delete the past tasks, we recommend to regularly (automatically) archive them into the *Task History* database, this to keep the **Task Monitor database** database size under limits.
- **fasttrack database:** used for the page workflows' Pages, Plates and Proofs View . The SQL Express Edition is not supported to be used for the Pages, Plates and Proofs Views.

Learn more in:

- [Performance Considerations](#) on page 1978.
- [Recommendations](#) on page 1979.

### Performance Considerations

The Automation Engine server performance depends on the performance of the used DBMS. This may be noticeable when searching a Job in the Pilot (for example while filtering ), when monitoring tasks (while filtering or scrolling), when executing tasks (while persisting their state, progress, ticket, ...) etc.

The number of tasks ran per day and the average number of connected operators (using a Pilot or Shuttle) determines the load put on the Automation Engine server and its DBMS. In addition, the setup of the DBMS and the environment in which it is running will also have an important effect on performance :

- The SQL Server software can be installed on the same computer as the Automation Engine software or on another computer.
- If the SQL Server is installed on another computer, then the network is involved. Under-performing network components may seriously influence DBMS performance. Other software running on that computer may influence performance as well.
- If the SQL Server is installed on the same computer as the Automation Engine (Master or Assistant), that may have an impact on the amount of memory and CPU resources available to Automation Engine.



- An SQL Server can be set up to run 1 instance (unnamed or the default), or even multiple (named) instances. In case of an Express Edition, each instance then has its own limitations (as described above), independent of the others.
- Each Automation Engine database may be configured independently of the others (to potentially point to different SQL Server instances on potentially different computers).

Issues with database performance can be noticed in the following situations (but are not limited to):

- a decline in average response time as experienced by users of the Pilot.
- a decline in average time between the moment of submitting a task and the moment the submitted task starts processing.

**Recommendations**

We recommend upgrading the SQL Server Express Edition to a full SQL Server in one or more of the following conditions:

- when more than 30.000 tasks are processed per day. This typically corresponds to 1.000 Jobs or files per day.
- when more than 100.000 processed tasks are constantly present in the Task Monitor (assuming that cleanup rules are set up adequately).
- when more than 20 active Pilots are connected simultaneously.
- when Automation Engine is licensed and configured to run more than 7 concurrent tasks.
- when the database size limitation risks to be exceeded.
- when you use the functionality of the Pages, Proofs and Plates views (in page imposition workflows).
- when there is a continuous load on the Automation Engine server (when production runs 24 hours per day).

When upgrading to a full SQL Server, special attention must go to provide sufficiently powerful hardware.

**Local versus Remote SQL Server**

Especially when you choose to work with a Full SQL Server, Esko recommends to not have this database server(s) installed on the Automation Engine Master server but on a separate computer. This is often done in case of large IT setups or to comply with specific internal IT requirements.



**Attention:** Using a remote SQL Server does means that there is a large amount of (extra) network traffic between that database server and the Automation Engine server software. This setup therefore requires a very reliable and fast network.



**Note:** It may be easier to increase the power of your Automation Engine server computer than to increase the speed of your network.



**Note:** Depending on the chosen licensing model of your SQL Server, the amount of CPUs of the computer that you install it on may have a significant impact on its cost. This may so also influence where you install it.

## Example Configurations

An Automation Engine setup is modular and scalable. This setup depends on the load that your server needs to carry and on the fail safe requirements.

### Small Size Configuration

This includes:

- One Master Server: set up as Automation Engine Master. The role of this server is managing Jobs and tasks as well as processing tasks.
- One File Server: the computer that stores the data that Automation Engine can access and process.



**Note:** Esko recommends to have a dedicated file server in every case, even for small size configurations.

### Medium Size Configuration

This includes:

- One Master Server: set up as Automation Engine Master. The role of this server is managing Jobs and tasks as well as processing tasks.
- One Assistant Server: configured as an Automation Engine Assistant. This server will only process tasks.
- One File Server: the computer that stores the data that Automation Engine can access and process.

### Large Configuration

This includes:

- One Master Server: set up as Automation Engine Master. The role of this server is managing Jobs and tasks as well as processing tasks.
- One Assistant Server: configured as an Automation Engine Assistant. This server will only process tasks.
- One File Server: the computer that stores the data that Automation Engine can access and process.
- One Viewing Assistant: configured to handle the Viewing sessions of all the clients.
- One Database Server: the Master server connects to a dedicated database server.

### Very Large configuration

This includes two separate server groups consisting of one Master server and two Assistant servers. Both server groups are completely independent units.

- Two Master Servers: both set up as Automation Engine Master. The role of these servers is managing (each their own) Jobs and tasks as well as processing (their own) tasks.
- Four Assistant Servers: configured as an Automation Engine Assistant. These servers will only process tasks.
- One File Server: the computer that stores the data that Automation Engine can access and process.

Per group, one server is set up as Automation Engine Master. The role of this server is reduced to only managing Jobs and tasks. The server has a relatively low amount of CPU and RAM. This server runs a full SQLServer database engine.

Two servers are configured as Assistant. Their role is to process tasks. These servers have a high amount of CPU and RAM.

The data processed by both server groups is stored on the file server.

### 27.3.2. Snapshots/Cloning

Taking a snapshot or cloning for fail safe purposes can be done under the condition that no licenses are activated on the server itself. When failing to do so, after restoring a snapshot of a virtual server or restoring a backup clone, the licenses will be broken.

This can be overcome by:

- temporarily deactivating the licenses before creating a snapshot or a clone.
- installing the licenses on a computer other than the Automation Engine server.

### 27.3.3. Installing Other Applications on the Automation Engine server computer

Automation Engine requires a dedicated server to run on. Installing other software might influence the functioning of Automation Engine and therefore is **strongly discouraged**.

#### Installing other Esko Applications on the Automation Engine server

- 1. WebCenter:** Automation Engine and WebCenter can not be installed on the same server. Both applications will malfunction if installed on the same server.
- 2. Imaging Engine:** Imaging Engine can be installed on the same server as Automation Engine. For performance reasons, Esko advises to have RIP components on different servers. The same is also valid for the legacy product FlexRip.
- 3. ArtPro+ and Esko classic editors (ArtPro PackEdge, Plato, i-cut Layout):** Esko editors are typically installed on a client station but can be installed on the same server as Automation Engine (for example to build templates). However, Esko does not recommend to use the server as a client workstation.

#### Virus Scanners and Firewalls

Make sure that virus scanners and firewalls (including OS firewalls) do not interfere with the Automation Engine software (blocking temp files, processes).

## 28. Installation Guide

---

### 28.1. How to Install Automation Engine 23

---

#### 28.1.1. Before installing Automation Engine

Before you install Automation Engine server software on your system, prepare or check these topics:

- First make sure you checked the [Pre-Installation IT Requirements Guide](#), a chapter in this [Automation Engine Complete Manual](#).
- Install Automation Engine on a "clean" system, where no Esko software has been installed yet. If any other version of Automation Engine was installed already, see the section [How to Upgrade to Automation Engine 23](#) on page 1991.
- You will need the DVD: "**Automation Engine 23 installation**".



**Note:** If you downloaded the software from [MySoftware.esko.com](http://MySoftware.esko.com), you will need to mount the corresponding .iso files as virtual DVD, or unpack the .iso files first.



**Note:** Make sure you are aware **which type of installation** you are doing. This is explained in the next page, in [Types of Installations](#).

- Your computer must meet the minimum requirements for the installation, as described on [www.esko.com/systemrequirements](http://www.esko.com/systemrequirements).
  - **Windows operating system:**
    - The windows OS on an AE server must be a "**Server**" type. The supported versions of the Microsoft Server OS are listed on <https://www.esko.com/systemrequirements>.
    - The Windows OS must be **64 bit**.
  - **Databases.** Automation Engine server software uses many databases. A standard installation installs the default supplied Microsoft SQL Express edition on the Automation Engine server.
    - The supported versions of Microsoft SQL Server are listed on <http://www.esko.com/systemrequirements>. In the Server Admin web page, use **Server Checks > Databases** to check if the installed database software is supported.
    - Automation Engine can use a full **SQL Server** instead of the default installed Express edition. Learn more about pro's and con's on [this page](#) in the chapter "[Pre-Install IT Requirements Guide](#)".
- You need (new) **software licenses** for Automation Engine: a product key file. If you do not have a product key file yet, contact [Esko Support](#).
- You need **internet** access from that server computer.

- You may **not** have an IIS web server installed on your system.
- You need to have **Administrator** privileges.
- Make sure your anti-virus software is not blocking the installation or configuration.

### 28.1.2. Types of Installations

The installation procedure will ask you which type of installation you want to do.



**Attention:** Before making these decisions, first learn about the possibilities of different database servers on [this page](#) in the chapter *Pre-Install IT Requirements* on page 1962.

- **Standard Installation**

- **Automation Engine Master, Device Manager or WebCenter OBGE.**

These installations also install the default supplied Microsoft SQL Express edition on the Automation Engine server.



**Note:** A **Device Manager** is a server software limited to communicating with CDI's or Kongsberg table devices. A **WebCenter OBGE** (On Board Graphics Engine) is a limited Automation Engine used to calculate the view files for an Esko WebCenter. This will typically be installed on the WebCenter Application Server.

- **Automation Engine Assistant.**

This installs an Automation Engine that you can (later) configure to be used as an Automation Engine Assistant. This option will *not* install a Microsoft SQL Express server.

- **Installation for use with an existing Microsoft SQL Server**

- **Automation Engine Master, Device Manager or WebCenter OBGE.**

These installations will use a remote SQL Server that is already available in the network. They will *not* install a Microsoft SQL Express server. For example: when you are installing an OBGE and you want it to use the SQL Server already used by your (full) WebCenter.



**Attention:** This type of installation includes an embedded mini database server engine. This embedded engine is not fit for production ; it is a temporary setup until you have chosen a different supported database engine.

### 28.1.3. How to Perform the Automation Engine 23 System Readiness Check

Before you install Automation Engine 23, a System Readiness Check is required. This checks whether the operating system is suited for installing and running this Esko product.

1. On the DVD, in the section **Software installation**, click the type of installation that fits your purpose (as explained in *Types of Installations* on page 1983).
2. In the section **Installation**, under **Instructions**, click **Run the Automation Engine System Readiness Check**.
3. At the end of the **Readiness Check**, read the resulting messages carefully.
4. If the **Readiness Check** resulted in any problem, correct it before proceeding.
5. Click **Exit**.

6. Proceed to install the [Esko License Server](#).

### 28.1.4. How to Install the Esko License Server

Use of the Automation Engine software is protected by licenses. These licenses are distributed as a product key file (in .HTML). To import the licenses into the Esko License Server, the product keys in the product key file must be activated using the **Network License Manager** tool.

You need:

- A product key file for the Automation Engine product components. If you do not have a product key file yet, contact [Esko Support](#).
- Internet access, to activate the licenses.
- An **Esko ID** in order to activate the licenses. Get one at <http://www.esko.com/licensing/CreateAccount>.

Follow these steps:

1. On the DVD, in the section **Installation**, under **Instructions**, click **Install the License Server Components**.
2. Install the Esko License Server by clicking **Install the Network License Manager**.
3. Follow the instructions of the installation wizard.
4. When the installation is finished, click **Network License manager > Network License Manager**.
5. **Local License Manager:** If you want to activate the license on your local computer (recommended in case of an Automation Engine Master), follow these steps:
  - a) In the **Esko Network License Manager**, click **Activate**.
  - b) Follow the instructions of the **Activate License Wizard**.
  - c) When asked how to activate the licenses, choose **on-line activation**.
  - d) When asked about the product keys, choose **I have a file containing one or more product keys**.
  - e) Click **Browse** to select the product key file.
  - f) When asked, fill in your **Account Name** and **Password**.
  - g) Click **Finish**.  
The licensed products you can use are now visible in the Esko License Server.
  - h) Close the License Manager and click **Go back** in the top-right corner of the page to return to the **Installation** page.
6. **Remote License Manager:** If you are using a remote license manager (typical in case of an Automation Engine Assistant), you only need to indicate where it is. Follow these steps:
  - a) In the **Network License manager**, open the **Help** menu and click **License client configuration**.
  - b) In the License Client Configuration window, in the field "**computer name of the License server**" type in the host name of the license server and click **Apply**.
  - c) Click **Exit**.
7. Now continue by clicking on [Install the prerequisite components](#).

### 28.1.5. How to Install the Automation Engine Prerequisite Components

Depending on the products to be installed on this particular system, various components are required for installation. The installation wizard for these prerequisite components checks the licenses, lists the

prerequisite components to install, requests confirmation for installation and then installs the required components.

The installation wizard installs the following components:

- **Microsoft Visual Studio Redistributables**
- **Esko CAD-X components** for Standard and Enterprise Editions.



**Note:** Do not install the CAD-X components when ArtiosCAD is already installed on that server.

- **Database Engine for the Automation Engine** components (if you choose a **Standard** Automation Engine Installation)

Follow these steps:

1. On the DVD, in the section **installation**, click **Install the Prerequisites Components**.
2. Follow the instructions of the installation wizard.
3. When you choose a **Standard** installation, when asked to enter a password for the SQL Server, enter a **Password**, confirm it and click **Use Password**.



**Note:** During the pre-installation of the Database Engine for Automation Engine, the Microsoft .NET Framework will be installed. You may get a warning saying that the system needs to be rebooted, followed by a fatal error "The SQL Server instance is not installed". If this happens, reboot your server and install the prerequisites again.

4. The installation wizard will ask you to close all Esko applications. Click **Yes** when asked **Ready to continue?**
5. Follow the instructions of the installation wizard.
6. Click **Continue**. Click **Yes** in the **Installshield Wizard Complete** message window.
7. Depending on your activated licenses, the **Automation Engine Prerequisite Components Installation** process may ask you separately about the **CAD-X** component installation for both the Standard Edition component and the Enterprise Edition component. If the Automation Engine is installed on the Application server, In both cases, click **Yes** when asked **Ready to continue?**
8. Follow the instructions of the installation wizard.
9. Click **Exit**.  
You will be redirected to the installation page to continue with the next step.

## 28.1.6. How to Install Automation Engine 23

1. After running the **System Readiness Check** and installing the **License Server Components**, when all prerequisites are fulfilled, you can start the installation.
2. Click the **Install Automation Engine 23** link on the installation page.  
The **Automation Engine 23 Software Installation** wizard will open up.
3. Follow the instructions of the installation wizard.
4. Read the **Software and Data license agreement** carefully and select **Yes, I accept the license agreement**.
5. When asked to select the products to install on this system, select **Automation Engine 23**.  
The group **Common Components** cannot be deselected and will be installed on all systems.
6. Select the **Destination Folder** for the chosen products or accept the defaults.

7. Follow the instructions of the installation wizard.
8. At the end of the installation, click **Finish**.

In case of a clean installation, a pop-up dialog asks the user name and password to use as the **System Account** for installing the Windows services. The proposed default user name is BGSYSTEM and the password must be provided, either for an existing local user or domain user, or for a local user to be created. The check continues until a strong enough password is provided. If the password does not match for the existing user, an error dialog will indicate "wrong user name and password".



**Note:** You can later change this system user using the [Server Config tool](#) on the AE server itself.



**Note:** Learn more about [Users and Groups](#) on page 1969 in the separate chapter [Pre-Install IT Requirements](#) on page 1962.

After installation of Automation Engine, a shortcut named **Automation Engine Server Config** is put on the desktop of the server computer.

Now continue with your [Initial Basic Setup](#) on page 1986.

## Initial Basic Setup

In case you did an installation with an existing SQL server, go to the dedicated section below.

### Standard Installation

The first time you install any of the client applications, Automation Engine has no user accounts at all so you will be asked to create an **Administrator** account, a requirement to start working with Automation Engine.

- On the server's desktop, the installation will have created a shortcut to the tool "**Automation Engine Server Config**".

Double click it to open the Server Config tool, which at this point will first present you the 'Get Started' page. This page enables you to create such an administrator account and get started.



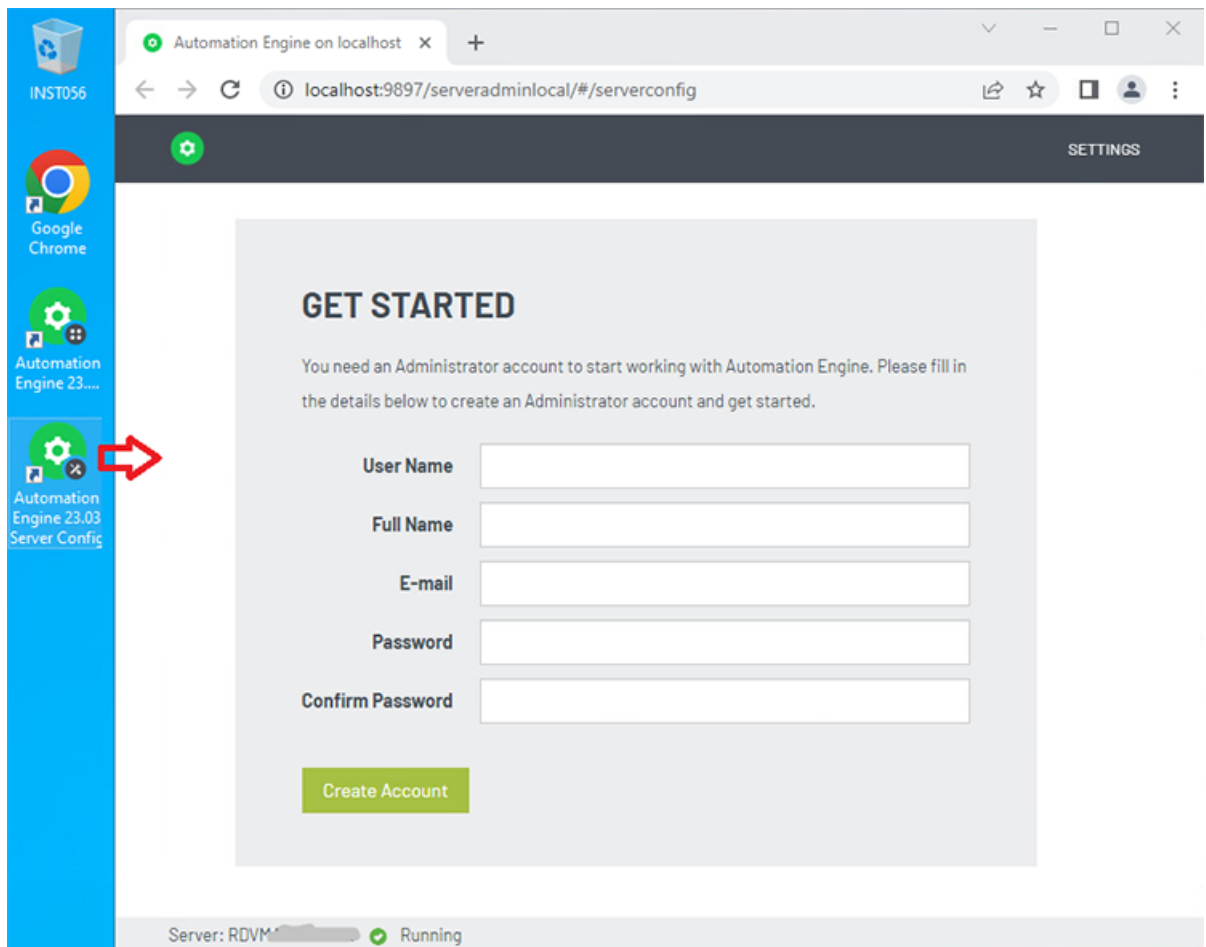

- Once the administrator user is created, you will be redirected to the main page of the [Server Config section](#) on page 1998, where you can do other basic configuration like configuring an identity provider for SSO or configuring HTTPS as protocol for the browser client or the Server Admin pages.

### Installation with an existing SQL database

Only in case of "[Installation for use with an existing Microsoft SQL Server](#):"

These are the same steps as above for a standard installation, apart from the creation of the databases:

- After creating the administrator account (as described above), the **Create Automation Engine Databases** page pops up. This is where you then need to configure and create your Automation Engine databases.

- Select your **SQL Server** and **Instance** name, type in the **sa** password and type in the **Database folder** and then
  - either click **Create** to start the automatic creation and configuration of the databases,
  - or, if you want to create and configure the databases manually, click **Continue using embedded databases**.



**Attention:** It is not supported to use Automation Engine with embedded databases in a production environment.



**Note:** Learn more about creating databases for Automation Engine in [Creating a Database](#) on page 2026. Learn more about configuring an Automation Engine database in [Automation Engine Database](#) on page 174.

- Once the databases are configured, you will be redirected to the main page of the [Server Config section](#) on page 1998, where you can do other basic configuration like configuring an identity provider for SSO or configuring HTTPS as protocol for the browser client or the Server Admin pages.

### 28.1.7. How to Install Pilot or Shuttle

The Automation Engine client software is distributed via the standard browser client



**Note:** Before version 20, this was done via the **Server Admin web page**.

1. Open your web browser and go to `http://AEServername:9000/`, where `AEServername` is the name of the computer running the Automation Engine server software.
2. In the menu **Apps & Tools**, tab **'Apps'**, go to **Desktop Client Applications** and click **Download** to save the executable somewhere on your client computer.

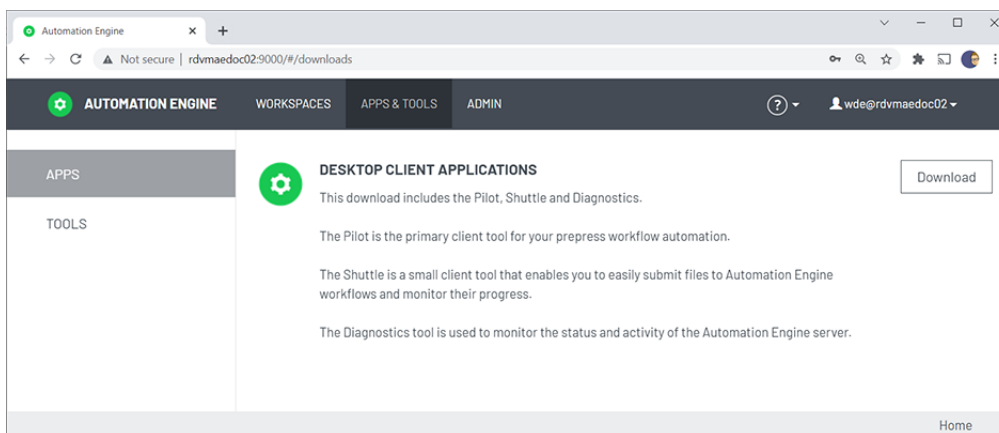

3. Start the installation by double-clicking the downloaded executable.
4. Follow the instructions of the installation wizard.
5. Read the **End User License Agreement** carefully, select **Yes, I accept the license agreement** and click **Next**.
6. Follow the instructions of the installation wizard.
7. At the end of the installation, click **Finish**.
8. Double-click the **Automation Engine Pilot** or **Shuttle** shortcut on the desktop.  
 This install of the client components also installed the Diagnostics tool (no desktop shortcut). Learn more in [Troubleshooting the Software](#) on page 2063.
9. Fill in the **User name**, **Password** and **Server Name**. You can here use the administrator account that you created earlier. Click **OK**.  
 The Pilot or Shuttle will start up.

### Initial Configuration (Pilot)

After an initial installation of Automation Engine, you typically want to configure a minimal setup that includes:

- **Containers.** Define which existing or new data shares contain the data that Automation Engine will be able to work with.

Learn more in [Containers](#) on page 146.



**Note:** An initial installation already creates an **ExampleJobContainer** on the disk where you installed the server software.

- **Users.** An initial installation creates a default user and user group.

Learn more in [Accounts Views](#) on page 152.

- **Task Cleanup Rules:** This is needed to avoid that your tasks database becomes too large and then slows down your server.



**Note:** A new installation will also have created a default Task Cleanup rule. Learn more about changing or adding such rules in [Task Cleanup Rules](#) on page 178.

- **Temporary data.**

Automation Engine creates a lot of temporary data on the folder defined by the Windows variable %BG\_TMP.

The folder where this variable is set to should be a fast drive with >50 GB free space.

By default this is installed on the same drive as where the software is installed. In case that disk threatens to fill up, we advise to redirect that variable to another place. Learn how to do this in [this KB article](#).

### 28.1.8. How to Open a Browser Client

To open an Automation Engine browser client, open a web browser on your workstation and go to `http://servername:9000`, where `servername` is the name of the computer running the Automation Engine server software.

Configuring an Automation Engine browser client is shown in the eLearning module 'About Installation and Configuration' of the [course about the workspace 'Roll-Fed Labels' \(on the Esko Blended Learning platform\)](#). This eLearning module is a summary of what is described in [the chapter 'Post-Install Configuration'](#) in this manual.



**Important:** When your browser client is not using HTTPS in its communication with the AE server, the sign-in dialog will mention this and refer to [this KB article](#) that explains how to set up using HTTPS.

#### Initial Configuration (Browser Client)

After an initial installation of Automation Engine, you typically want to configure a minimal setup that includes:

- **Containers**

At first sign in to the browser client, you will be asked to define a **Data Container**. Define which existing or new data shares contain the data that Automation Engine will be able to work with.



**Note:** An initial installation already creates an **ExampleJobContainer** on the disk where you installed the server software.

- **Users**

At first sign in to the browser client, you will also be asked to create an administrator user.



**Note:** The others can later be created via the menu **Admin > Users**.

- **Task Cleanup Rules**

The product preparation tasks that run on the server will be cleaned up automatically by default 'Task Cleanup rules'.

- **Temporary data.**

Automation Engine creates a lot of temporary data on the folder defined by the Windows variable %BG\_TMP.

The folder where this variable is set to should be a fast drive with >50 GB free space.

By default this is installed on the same drive as where the software is installed. In case that disk threatens to fill up, we advise to redirect that variable to another place. Learn how to do this in [this KB article](#).

## 28.2. How to Create a full Backup of Automation Engine 23

---

You can create backups with the tools available in **Server Admin** section of the **Automation Engine Server Admin web page**.

These tools are documented in the page [Backup](#) of the chapter [Automation Engine Server Management](#) on page 1997.

## 28.3. How to Upgrade to Automation Engine 23

---

You need to upgrade to Automation Engine 23 in the following order:

1. [Create a backup of your current Automation Engine](#).
2. [Perform the System Readiness Check](#).
3. [Upgrade the License Server](#).
4. [Upgrade the prerequisite components](#).
5. [Upgrade the Automation Engine software](#).

### 28.3.1. Before Upgrading to Automation Engine 23

Before you upgrade to Automation Engine 23, prepare the following:

- Make sure you have a [backup](#).
- Check the document [Pre-Install IT Requirements](#) on page 1962, a separate chapter in [the Automation Engine complete manual](#).
- You will need the DVD "**Automation Engine 23 installation**".



**Note:** If you downloaded the software from [MySoftware.esko.com](#), you will need to mount the corresponding .iso file as virtual DVD.



**Note:** AE versions from before version 20 were installed with default passwords. We recommend changing these. Learn more in this [KB article](#).

- You must have a working version of **Automation Engine 16** or higher.
- Your computer must meet the minimum requirements for the installation, as described on [www.esko.com/en/SystemRequirements](#).



**Attention:** Make sure to check that the version of SQL Server that your previous AE version was using as database server is still supported.

- You need a product key file for the upgrade (every new major version requires a new license set). If you do not have a product key file yet, contact [Esko Support](#).

- Use [Status Overview](#) on page 2010 to make sure no more users are connected or using the system.
- The upgrade will check if you are still using tasks that have become **Outdated** in the version that you are installing. If any are found, you will have the chance to abort the installation. Learn more about such tasks in [Outdated and Soon Outdated Tasks in this Version](#) on page 531.

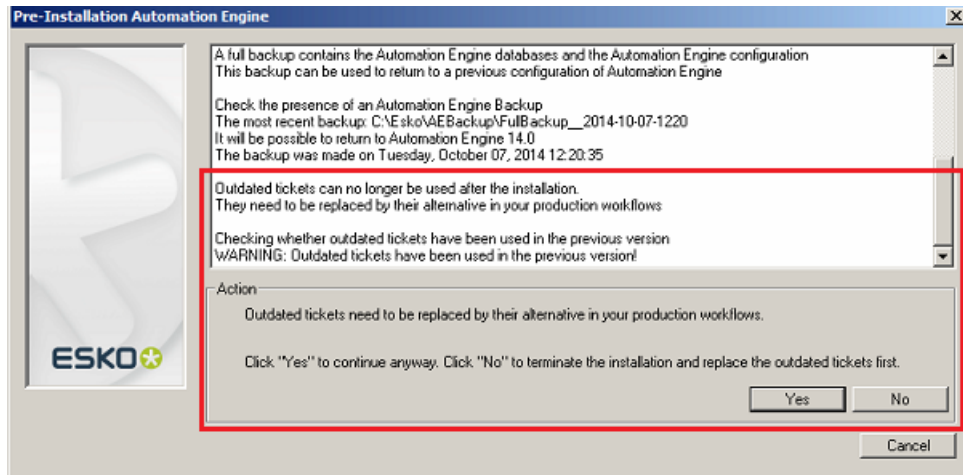

- Reboot the server before upgrading Automation Engine.

### 28.3.2. How to Perform the Automation Engine 23 System Readiness Check

1. On the DVD, in the section **Installation**, under **Instructions**, click **Run the Automation Engine Readiness Check**.

Learn more in [How to Perform the Automation Engine 23 System Readiness Check](#) on page 1983.

2. Proceed to install the **Esko License Server**. Click **Install the License Server Components**.

### 28.3.3. How to upgrade the Esko License Server Components

The Automation Engine 23 product is protected by (new) licenses. These licenses are distributed as a product key file (a .HTML file). To import these new licenses into the Esko License Server, you must first upgrade the Esko License Server components.

1. On the DVD, in the section **Installation**, click **Install the License Server Components**.
2. Follow the instructions of the installation wizard.
 

During the upgrade of the **Network License Manager**, the current Esko License Server will be stopped temporary, during which the currently used licenses will be unavailable.
3. When the installation has finished, click **Load the new licenses**.
4. In the **Load new licenses** window, click **Activate Server Licenses**.
5. In the **Network License Manager**, click **Activate**.
6. Follow the instructions of the **Activate License Wizard**.
7. Select **on-line activation**.
8. Select **I have a file containing one or more product keys**.
9. Click **Browse** to select the product key file.

10. Fill in your **Account Name** and **Password**.
11. Click **Finish**.  
The licenses for the upgraded products are now listed in the License Manager.
12. Close the License Manager and click **Go back** in the top-right corner of the page.
13. Click on **Continue with the installation of the prerequisite components** link.

### 28.3.4. How to Upgrade the Prerequisite Components

Follow these steps to upgrade the **Prerequisite Components**:

1. On the installation page, click **Install the prerequisite components**.
2. Follow the instructions of the installation wizard.
3. The installation wizard will ask you to close all Esko applications. Click **Yes** when asked **Ready to continue?**
4. Follow the instructions of the installation wizard.
5. Click **Continue**. Click **Yes** in the **Installshield Wizard Complete** message window.
6. **Automation Engine 22 Prerequisite Components Installation** window will ask you about **CAD-X** component installation, both 'Standard' and 'Enterprise'. Click **Yes** if ArtiosCAD is not installed.
7. Follow the instructions of the installation wizard
8. Click **Exit**.  
You will be redirected to the installation page to continue with the next step.

### 28.3.5. How to Upgrade Automation Engine software

After the upgrade of the prerequisite components, your system is ready to upgrade to Automation Engine 23.

1. Click on the **Install the Esko Software 23 Automation Engine** link on the installation page.  
The Automation Engine 21 Software Installation wizard will open up.
2. Follow the instructions of the installation wizard.
3. Read the **Software and Data license agreement** carefully and select **Yes, I accept the license agreement**.
4. When asked to select the products to install on this system, select **Automation Engine 23**.  
The group **Common Components** cannot be deselected and will be installed on all systems.
5. Follow the instructions of the installation wizard.
6. Select the **Destination Folder** for the chosen products or accept the defaults.
7. During the pre-installation this question will appear "If you continue Automation Engine <number-of-the-new-version> will be installed but it may not be possible to return to <number-of-your-current-version>. Do you want to continue the installation anyway?". Answer **Yes**.
8. Follow the instructions of the installation wizard.
9. At the end of the installation, click **Finish**.
10. Now install the latest Automation Engine client applications. Learn more in [How to Install Pilot or Shuttle](#) on page 1988.

## 28.4. How to Upgrade onto a New Server Computer

---

These are the typical cases when you want to change the hardware (computer) of your Automation Engine server:

- You decided yourself that the server computer needs to be updated, usually for performance reasons.
- Your server computer no longer matches Esko's requirements for an Automation Engine server. A typical case is when the Windows OS is no longer supported.



**Note:** Your new server computer can have a different name than the old server computer.

To move your Automation Engine server configuration to a new server, follow these main steps:

### 1. Install Automation Engine on the new server

First you install Automation Engine on this 'virgin' new server. Follow the standard procedure as described in [How to Install Automation Engine 23](#) on page 1982.

### 2. Backup your old server configuration, using the backup tool from your old Automation Engine server software

To get the configuration of your old server onto your new one, use the backup tool that is offered in the **Automation Engine Server Admin web page** of the old server (go to `http://<name-of-your-OLD-server>:9999/` and sign in).

### 3. Restore that backup on your new AE server. Choose the type 'Migrate Configuration'.

To do this, use the **Restore** function as documented in [Restore](#) on page 2023 . Most important is that the restore type "**Migrate Configuration**" is chosen.

## 28.5. How to Repair an Automation Engine Server

---

You typically need to repair a system when a software update failed or when program files got deleted or became corrupt (for example a virus can cause such files damage).



**Note:** Only Automation Engine components of the same version as the one on the DVD can be repaired/re-installed.

To repair the Automation Engine server software, proceed as follows:

#### 1. Open the **Automation Engine Software Installation** window:

- If you insert the distribution DVD into the DVD drive, or mount the corresponding .iso file, the window appears automatically.



- If you unpacked a downloaded .iso file, or if the window doesn't open automatically, double-click setup.exe in the root folder.
2. Select the installation language.
  3. Click **Proceed to the installation**.
  4. Click **Repair / re-install Automation Engine** and **Choose** which component you want to repair.

## 28.6. How to Uninstall Automation Engine server software

---

When you uninstall a version of Automation Engine, only that Automation Engine server software is removed.

Resource files like color data, fonts or curves are not touched.

You can choose to uninstall the current version or an older version.

The uninstaller opens a dialog showing all installed software specific to the Automation Engine version that can be uninstalled. The user can select which software to uninstall.



**Note:** Although technically not required, it is a good standard practice to make a [backup](#) of your current configuration before doing an un-installation.

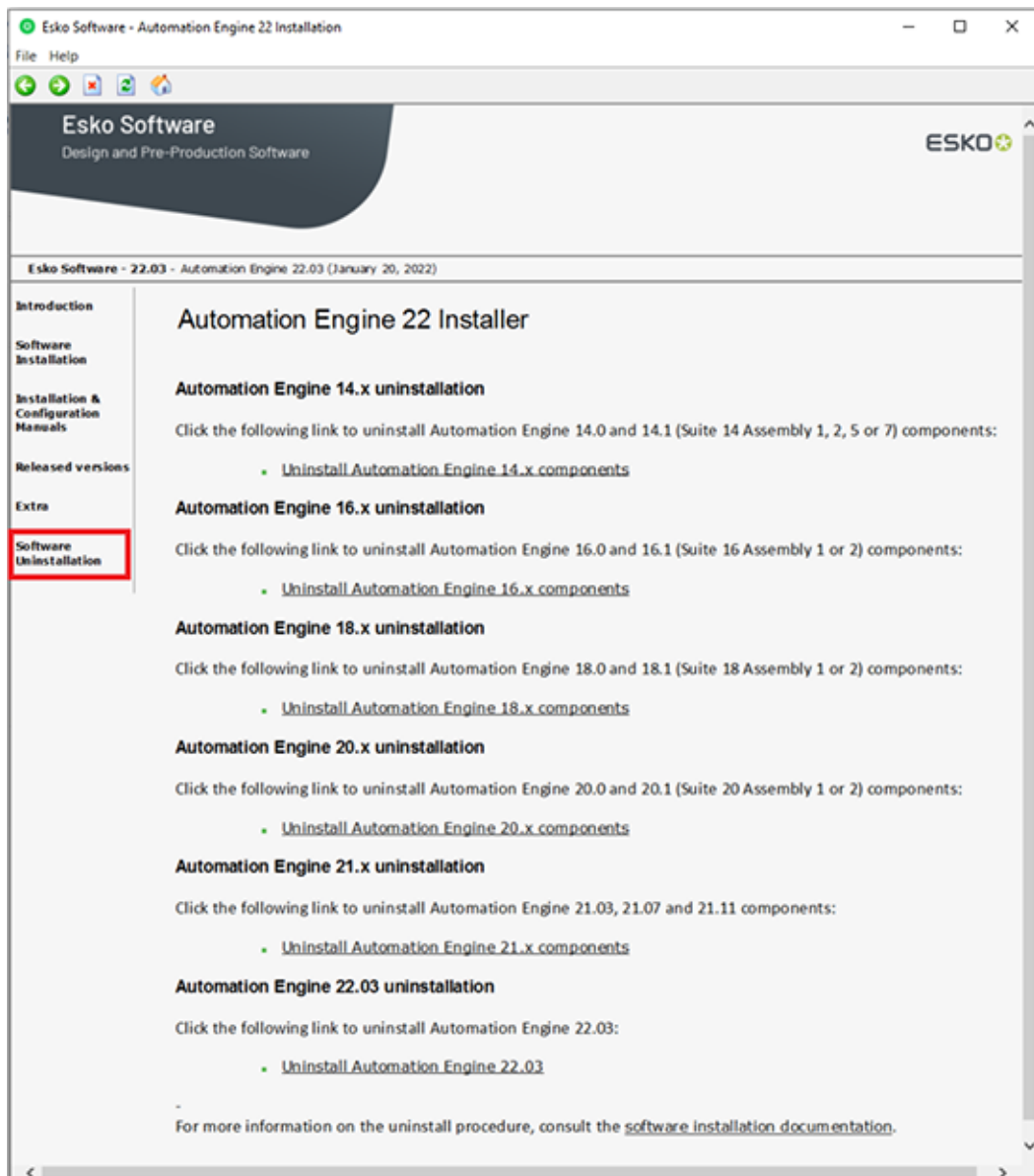

## 28.7. How to Install the Configuration Manager

The **Configuration Manager** tool collects a lot of data regarding software versions, hot-fixes, OS etc. This information can be useful for Esko customer support. It can also alert you on expiring licenses.

Only install the **Configuration Manager** if there is no **Configuration Manager** active on your network yet. **There can only be one Configuration Manager** active on the network.

How to install the **Configuration Manager** is described in its own (installation) manual. Find it on <http://help.esko.com/products/Configuration%20Manager>.

# 29. Automation Engine Server Management

## 29.1. The AE Server CONFIG web page



**Attention:** This page can only be accessed from a browser **on the Automation Engine server computer itself**.

### Concept

This web page serves to administer only very specific parts of the configuration.

Q: Why is this a separate tool than the [other Server Admin web page](#)?

- A: The signing in to a server admin page requires you to have credentials that correspond to a Windows user on your AE server computer that has administrative rights. The main reason for this is that even when the AE server software is down, you still need to be able to administer some of that server software.

There are 2 ways to open the Server Config web page:

#### On the AE server computer,

- either type this URL in the browser: `http://localhost:9897/`
- or go to **Start > (Programs) > Esko > Automation Engine Server Config** (which also opens a browser tab to that page).



**Note:** When you open this page at a moment when there is no administrator account yet on that Automation Engine (typically right after a first installation), then the [Get Started page](#) is presented first. This page serves to create that initial administrator account.

This page offers 2 sections:

- [Server Config](#) (unique in this tool)
- [Server Admin](#) (same content as the separate web pages).

### 29.1.1. The Get Started page



**Restriction:** This page only appears after a first installation of an Automation Engine server software.

After a first installation, Automation Engine has no (administrator) user accounts at all.

You need an administrator account to start working with Automation Engine.

When no administrator account is present and when you open this Server Config tool, you will first see the 'Get Started' page that invites you to create this account.

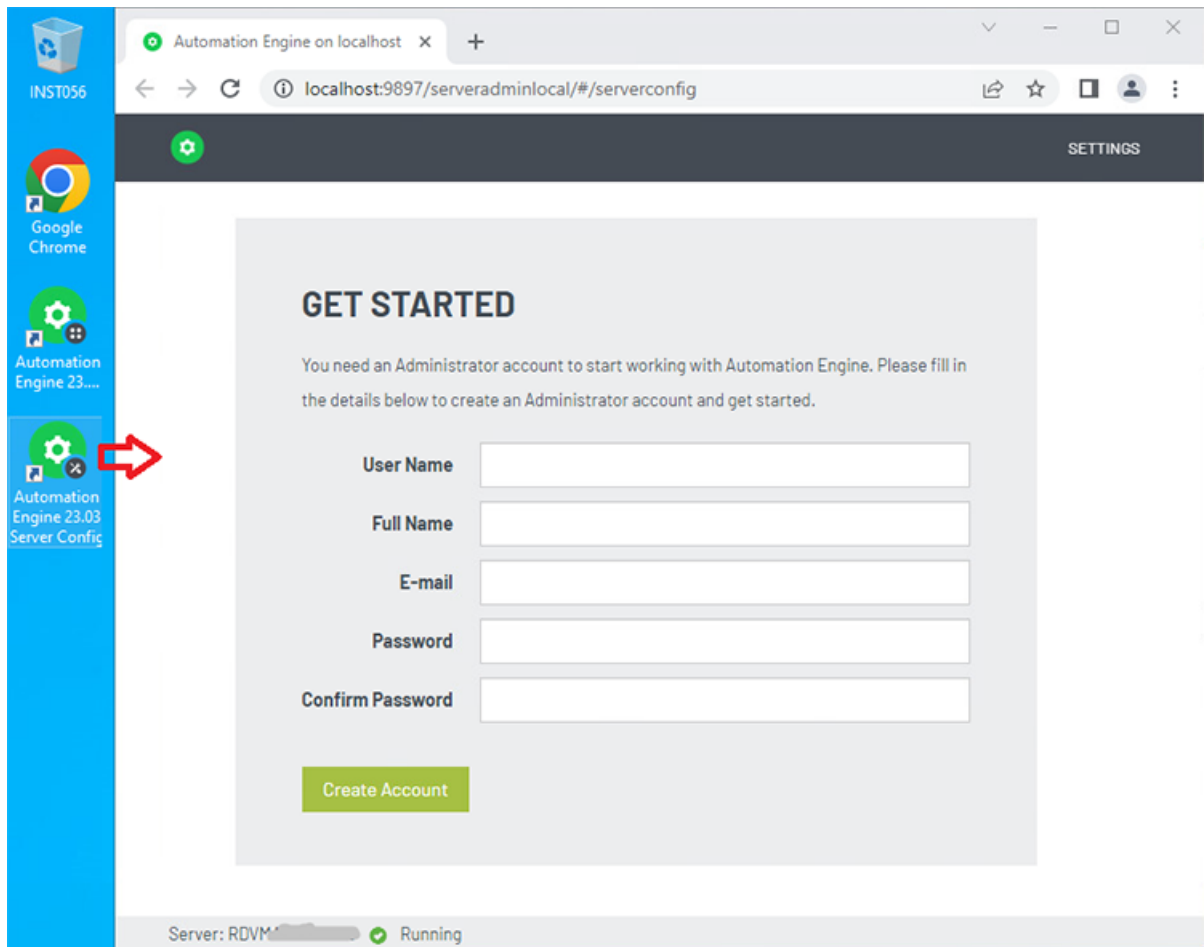

- Fill in these fields (all are required): **User Name**, **Full Name**, **E-mail**, **Password**, **Confirm Password**.
- Then click **Create Account**. The user account will be created and the [Server Config page](#) will be shown.

### 29.1.2. Server Config section

- [Identity Providers](#) on page 1998
- [Browser Client](#) on page 2005
- [Remote Server Admin](#) on page 2008
- [System History](#) on page 2008

#### Identity Providers

An Identity Provider (IdP) is an application that manages identity information and that also provides authentication services to other applications within a defined network. Learn more on its [Wiki page](#).

Learn the basics about Automation Engine's user model in [Accounts Views](#) and more technical details on the page [Users and Groups](#) on page 1969.

Automation Engine supports 4 methods of authentication, corresponding to 4 different Identity Providers.

They can be individually configured: **OpenID** authentication via Okta or Azure AD can be added or removed, **LDAP** and **Windows** authentication can be enabled or disabled, **Internal** authentication is always enabled.



**Note:** Windows user authentication is not available nor shown in an [AE SaaS](#) setup.

### Basic workings

- The OpenID configurations will be shown in the sign-in dialogs of Pilot (as links) and My Workspace (as buttons).
- When signing in without using an OpenID, the enabled authentication methods will be used in this order: LDAP, then Internal, then Windows.

### Page editing mode

By default, the lock icon  is closed to prevent accidental changes.

Click the lock to open it and so start the editing mode.

As soon as you make any change, the **Revert** and **Apply** buttons appear.

- Click **Apply** to apply and save the changes you made.
- Click **Revert** to discard the changes and go back to the last saved settings.
- Click  to close the lock and so go back to read-only mode.
  - When you lock the page without applying, the settings are automatically reverted.

## OpenID

### Introduction

OpenID is an open standard and decentralized authentication protocol promoted by the non-profit OpenID Foundation.

Learn more about OpenID and OpenID Connect (OIDC) on its [Wiki page](#).





### Configuration - the basics

- The overview table.

You can have a maximum of 3 OpenID configurations. An example:

OPENID

You can have up to 3 OpenID configurations. They will appear in alphabetical order by name in the Pilot or My Workspace sign-in dialogs.

ENABLED	NAME	TYPE	DESCRIPTION	ACTIONS
<input checked="" type="checkbox"/>	Azure_demo	Azure AD	Tenant ID: 2aabb1e1... Client ID:...	 
<input checked="" type="checkbox"/>	AzureByPlatform	Azure AD	(managed by Esko)	
<input checked="" type="checkbox"/>	OKTARD	Okta	Okta Domain: esko...com, Client ID: 0oa4yv3...	 

- **Enabled:** Until it is enabled, a user will not be able to see this way of signing in. This is handy when your admin is still setting up or changing a configuration.
- **Name:** Their name is how they will be offered to the user in the sign-in dialogs (in a Pilot as links, in a browser as buttons).
- **Type:** The chosen type.
- **Description:**
  - For Azure AD, this field shows the Tenant ID and the Client ID.
  - For Okta, this field shows the Okta Domain and the Client ID.
  - (AE SaaS only) **(managed by Esko)** indicates that this configuration was set up by staff from Esko Platform Operations that manages your SaaS setup within the data center.
- **Actions:** Admin users can edit or delete a configuration.
- Adding a Configuration
  - Click **Add OpenID Configuration** to open the dialog.
  - First choose the **Type: Azure AD** or **Okta**.

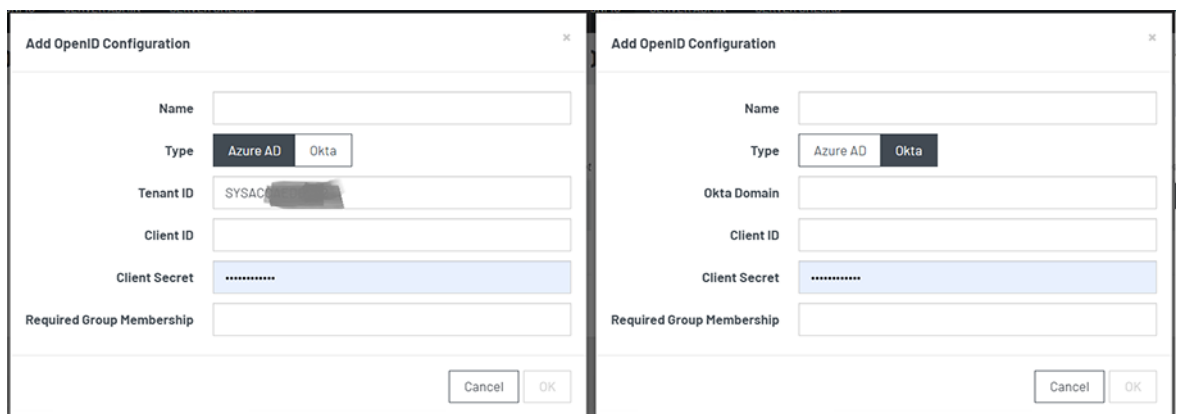

All fields are mandatory, except the 'Required Group Membership'.

- **Name:**



**Note:** This name may not contain a space or any of these characters: #%&|\\*?=:/@'{} [ ]<>()

- **Tenant ID / Okta Domain:** Ask your SSO administrator. Learn more below.

- **Client ID:** Ask your SSO administrator. Learn more below.

- **Client Secret:** Ask your SSO administrator. Learn more below.



**Note:** This field behaves as a password field ; its actual value is not shown.

- **Required Group Membership:** Automation Engine will only admit a user to sign in when this user is also a member of the Identity Provider groups listed in this field. Learn more about this same setting on the [page about LDAP](#).



**Note:** In case of multiple groups, define them in a comma separated list.



**Note:** This field is optional. When left empty, membership of any group is allowed.



**Important:** When all is configured well (both at the Automation Engine and at the Identity Provider side), an automatic one-on-one group mapping is applied between Identity Provider groups and Automation Engine groups.

This implies that if both an Identity Provider group and an Automation Engine group exist with the same name, a user belonging to a specific Identity Provider group will automatically become member of the same Automation Engine group when signing in and hence immediately pick up Automation Engine roles / access rights from that Automation Engine group.

- The **OK** button is enabled when all mandatory fields are filled in.

### Configuration - in detail

- **Azure AD**

- To enable users known to Azure AD to sign in to Automation Engine, a dedicated app needs to be registered by your SSO administrator in the Azure Active Directory admin center.

The app needs to be configured with a 'Redirect URI' for a 'Web' platform that needs to be exactly like this:

- "https://<fully\_qualified\_lowercase\_domain\_name\_of\_the\_system\_on\_which\_Automation\_Eng\_ ae/auth/auth-redirecturi.idp" (without the quotes).



**Note:** In an AE SaaS setup, Esko staff will provide the public name of the Automation Engine SaaS (master) server needed for the fully qualified domain name (FQDN) above.

- The 'Front-channel logout URL' should be set to:

- "https://  
<fully\_qualified\_lowercase\_domain\_name\_of\_the\_system\_on\_which\_Automation\_Eng  
the quotes).
- A new client secret needs to be added as well.
- And after that, the 'Directory (tenant) ID', the 'Application (client) ID' and the client secret's value (not it's ID!) should be captured and transferred to the fields mentioned above.
- Finally, the app needs to be granted the necessary permissions (preferably with admin consent to avoid bothering every user at first sign-in to consent individually).

These Microsoft Graph API delegated permissions are needed:

- email
- openid
- profile
- User.Read
- GroupMember.Read.All



**Note:** When a user known to Azure AD signs in for the first time, a corresponding Automation Engine user is created with an AE 'User Name' that matches the 'User Principal Name' in Azure AD, and an AE 'Full name' that matches the 'Display Name' in Azure AD. This Automation Engine user will have 'Azure AD' indicated as 'Provider'.

• **Okta**

- To enable users known to Okta to sign in to Automation Engine, a dedicated app needs to be created by your SSO administrator in the Okta Admin Console.

The app needs to be configured as a 'Native application' with 'Sign-in Redirect URIs' adapted to be exactly like this:

- "https://  
<fully\_qualified\_lowercase\_domain\_name\_of\_the\_system\_on\_which\_Automation\_Eng  
ae/auth/auth-redirecturi.idp" (without the quotes).



**Note:** In an AE SaaS setup, Esko staff will provide the public name of the Automation Engine SaaS (master) server needed for the fully qualified domain name (FQDN) above.

- The 'Sign-out Redirect URIs' should be adapted to:
  - "https://  
<fully\_qualified\_lowercase\_domain\_name\_of\_the\_system\_on\_which\_Automation\_Eng  
the quotes).
- 'Client Authentication' needs to be configured with a 'Client secret', while no PKCE is needed for additional verification.
- After that, the 'Client ID' and generated 'Secret' should be captured and transferred to the fields mentioned above.
- Finally, a groups claim filter needs to be set for the 'OpenID Connect ID Token' as 'groups' 'Matches regex' with value ". \*" (without the quotes).





**Note:** When a user known to Okta signs in for the first time, a corresponding Automation Engine user is created with an AE 'User Name' that matches the 'Username' in Okta, and an AE 'Full Name' that matches the 'Person' in Okta (which by itself is a combination of the 'First name' and 'Last name' in Okta). This Automation Engine user will have 'Okta' indicated as 'Provider'.

**LDAP**

Select **LDAP authentication** when you want to have LDAP accounts able to sign in to Automation Engine.



**Attention:** Having the LDAP server behind a proxy is not supported.



**Note:** LDAP authentication is not available nor shown in an [AE SaaS](#) setup.

The configurations settings only appear when the LDAP authentication is selected.



**Note:** Deselecting the LDAP authentication disables the authentication method but keeps the settings. Enabling it again restores the previous settings.

An example:

LDAP

LDAP authentication

LDAP Server: ldapserver01.printing-company.com

System User Name: ldap\_user

System User Password: .....

User Distinguished Name (DN): DC=printing-company,DC=com

Required Group Membership: Group\_AE\_Admins,Group\_AE\_Users

Use secure connection (LDAPS)

- **LDAP Server:** Internal domain address of the LDAP server
- **System user Name:** System user name of the LDAP server. Typically this is a service account in the domain. For security reasons, this user typically does not have access to (file) servers.
- **System user Password:** System password of the LDAP server. Make sure that the password never expires and that no one can change the password.
- **User Distinguished Name (DN):** This is the unique path (specified as a Distinguished Name - DN) to an entry in the Directory Information Tree (DIT) at or below which user specific information can be retrieved.

Typically a path to the top level domain is sufficient (see the above screenshot, where no Organizational Unit (OU) components are needed, and two Domain Component (DC) components will do). Note that components in the path must be comma separated.

- **Required Group Membership:** Because it could be that not all users in the Active Directory are allowed to use Esko applications, or AE clients in particular. In such case, all the users that are allowed to work with AE could be assigned membership to an Active Directory group named, for example, *Group\_AE\_Users*. Then enter this group name *Group\_AE\_Users* in this field. This will enforce that only members of that Active Directory Group can use the Pilot.

When you here enter multiple groups, it needs to be a comma separated list.

This field is optional. When left empty, membership of any group is allowed.



**Attention:** Nested groups are not supported! In Active Directory, you can set up a complex structure of groups within groups. However, this tool does not support nested groups! An example:

- Members that should use Automation Engine could be assigned membership to the AD group *Group\_AE\_Users*, and that group *Group\_AE\_Users* could be inside a group *Group\_Production*.
- In case you here only enter the larger group *Group\_Production*, and a member of *Group\_AE\_Users* tries to sign in, Automation Engine will not detect that this member is a also a member of *Group\_Production*, which in theory means he should be allowed access.
- Conclusion: The user trying to sign-in must be a direct member of one of the here specified groups (being a member of one of the sub-groups of the specified group(s) is not enough).

- **Use Secure Connection (LDAPS):** Select this when this is the case.



**Attention:** Users will not show up in the Pilot interface until they have signed in the first time. This is because there is no automatic 'import' action of Active Directory users: it is not the case that for every user in the Active Directory, a user entry is created in the AE database. It is only when such an LDAP user signs in for the first time (i.e has given a valid account name and password), that an entry is created in the AE database. And once an entry is created in the AE database, only then you can start setting AE permissions for it. That is why, when a new entry is created, it does not necessarily mean that that user may or can already use Automation Engine.



**Attention:** To avoid seeing an error the first time a user tries to sign in, you should first configure and assign roles to give users in those groups the 'user access right' to sign in to the Pilot. Remember: a user can obtain a certain access right because he is assigned a role that includes that right OR because he is member of a group that was assigned a role that includes that right.



**Note:** To avoid that an administrator has to do all this for every user that complains that his first sign-in did not succeed, we advise a one-on-one mapping between group names in the Identity Provider (for example Active Directory) and group names in the AE database.

In short: we advise that users as defined in the Active Directory should be assigned membership to an IDP (Active Directory) group that has the same name as a group that is prepared/created on the AE database side.

The result is then that, at their first successful sign in attempt,

- their entry in the AE users database is created
- AND they immediately gain membership of some AE group with the same name,
  - which means they get such and such role/right/etc.
  - which then means that, at this first sign-in attempt, they are allowed to sign in to the Pilot.

### Internal

This type of authentication is the default identity provider, internally in Automation Engine.

- **Enforce complex passwords:** Select this when you require the Automation Engine internal users to have complex passwords. It then sets these password requirements:
  - at least 8 characters
  - at least 1 digit
  - at least 1 uppercase character
  - at least 1 special character ! @ # \$ % ^ & \* ( ) \_ +
  - excluding spaces

### Windows - Soon Outdated

Windows based authentication is available if you still want to use local Windows users in Automation Engine.



**Attention:** Windows based authentication will become obsolete in a next major version. If you are still using Windows users, we advise you to migrate these to **Internal** or **LDAP** users as explained in [Migrating Users](#) on page 1972.



**Note:** Windows user authentication is not available nor shown in an [AE SaaS](#) setup.

### Browser Client

Learn about using the browser client in the dedicated chapter [Browser Client Workspaces](#) on page 886.

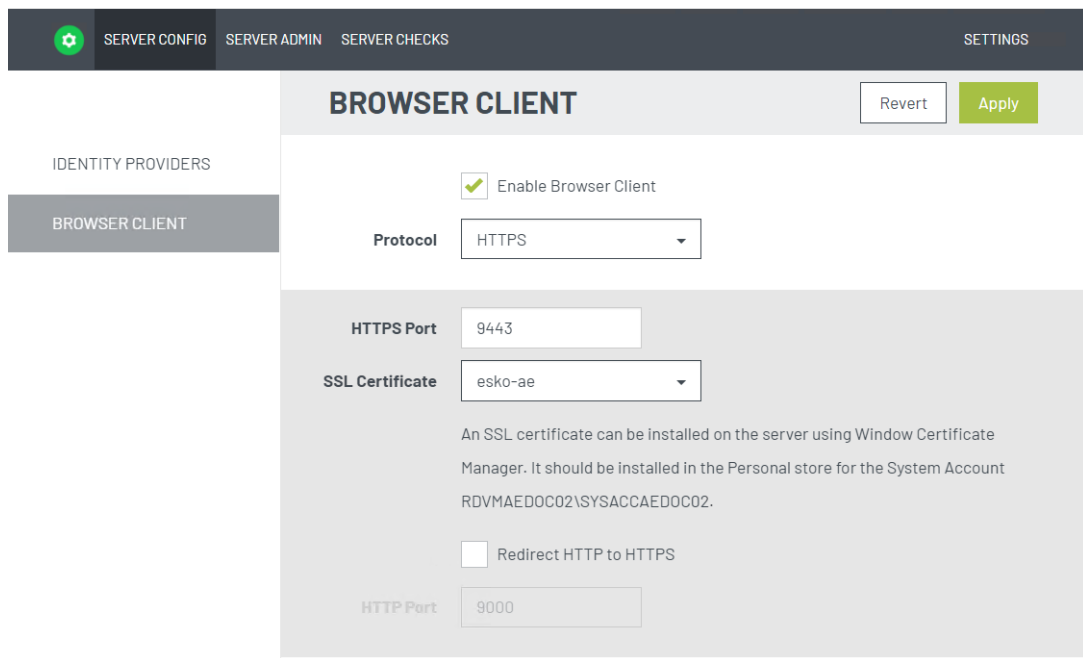

- **Enable Browser Client**

- **Protocol**

- **HTTP**

- **HTTP Port.** Default is 9000. When changing this number, you will be asked to confirm.



**Attention:** Do not change this port number when tasks are running on the server.

- **HTTPS:**

We here give a summary of how to configure an HTTPS connection. Find a more detailed description [further below](#).

- **HTTPS Port:** Default is 9443. When changing this number, you will be asked to confirm.



**Attention:** Do not change this port number when tasks are running on the server.

- **SSL Certificate Port:** By default, a self-signed certificate will be used. The browser will show a warning when accessing the browser client. The actual message depends on the used browser and its version.

You can add a certificate to the list by installing an SSL certificate on the server using Windows Certificate Manager. It should be installed in the Personal store for the System Account <servername>\BGSYSTEM.

- **Redirect HTTP to HTTPS:** When selected, type in the **HTTP Port**. The default HTTP port is 9000. When changing this number, you will be asked to confirm.



**Attention:** Do not change this port number when tasks are running on the server.

- When you deselect **Enable Browser Client**, the browser client can no longer be accessed on the LAN.

When changing this selection, you will be asked to click 'apply'.



**Attention:** Do not make these changes when tasks are running on the server.

### How to set up an HTTPS protocol

- **Prerequisites**

- To correctly configure the HTTPS connection, you need an official SSL certificate from a recognized certificate authority. If you don't supply an official certificate, a self-signed certificate will be used. In that case, your browser will show a warning that your connection is not secure because the authenticity of the certificate can not be verified.
- Changing the connection settings requires a [restart of the AE server software](#) (which includes the required restart of the service 'Imservice' aka 'job server'). When you do this, make sure that there are no tasks running on the Automation Engine Server.

- **Procedure**

1. Import the certificate into the Windows Certificate Store for the Automation Engine system account. By default, this user is 'BGSystem'.



**Note:** Below steps assume that the AE [system account](#) name is 'BGSystem'. When that is no longer the case, just replace 'BGSystem' in below steps with your custom name of your system account.

1. On the AE server computer, log in as user BGSystem and go to the **Manage computer certificates** control panel.  
  
Alternatively, when logged in as another user, you can launch the 'Manage User Certificates' control panel by following these steps:
  1. To open a command prompt, type 'cmd' in the search field in the Windows Task bar and press 'Enter'.
  2. Enter following command: `runas /user:BGSystem "cmd /c mmc certmgr.msc"`
  3. Enter the password for the user BGSystem.
2. In the left pane, navigate to the *Personal > Certificates* and right-click in *Certificates*. Choose **All Tasks... > Import ...**
3. Navigate to the location where the certificate is stored and follow the wizard.
4. Once the wizard is finished, the imported certificate should show up in the list on the right. Make sure the entry *Personal > Certificates* is selected.
5. Check the column **Friendly Name** for the imported certificate.
  - Take note of this name ; it is used later on to configure Automation Engine.
  - If the certificate does not have a 'Friendly Name' then right-click the certificate and choose > **Properties**.
  - On the first tab **General**, the first input field is used to set the Friendly Name.
  - Click Apply and Close the dialog. Verify that the Friendly Name has now been set for that certificate.
2. In a browser, go to the [Server Config web page](#) and to the tab **Browser Client**.
3. In **Protocol**, select **Use HTTPS**.
4. In **SSL Certificate**, select the Friendly Name from the list of SSL Certificates.
5. It is recommended to disable http: deselect **Use HTTP** and optionally enable **Redirect HTTP to HTTPS**.

- 6. Press **Apply**.

## Remote Server Admin

### Concept

This page mainly serves 2 use cases:

- Some administrators, for example in an AE SaaS setup, may for security reasons not allow that the Server Admin page is available on other computers than here on the Automation Engine server itself.

A specific reason for doing this is that they rely on Windows users and they don't want Windows users to be known outside of the system, because an other way of accessing this system is used. So if no one is supposed to access Server Admin remotely, it is better and safer to just disable it.

- And if the remote access to the Server Admin pages is allowed, requiring HTTPS communication will avoid less secure communication (of passwords for example).

### Settings

- **Enable remote access to Server Admin:**

When you deselect this, the (separate) Server Admin tool can no longer be accessed on the LAN, and so only on this Automation Engine server computer.

When changing this selection, you will be asked to click 'Apply'.

- **Port:** Default port is 9999.

- **Protocol**

- **HTTP**

- **HTTP Port.** Default is 9999. When changing this number, you will be asked to confirm.

- **HTTPS:**

We here give a summary of how to configure an HTTPS connection. Find a more detailed description further below.

- **SSL Certificate Port:** By default, a self-signed certificate will be used. The browser will show a warning when accessing the browser client. The actual message depends on the used browser and its version.

You can add a certificate to the list by installing an SSL certificate on the server using Window Certificate Manager. It should be installed in the Personal store for the System Account <servername>\BGSYSTEM.

### How to set up an HTTPS protocol

An SSL certificate can be installed on the server using Window Certificate Manager. It should be installed in the Personal store for the [System Account](#).

Learn more at the bottom of [the page on the tab Browser Client](#).

## System History

This page is available both in the ['Server Config' web pages](#) and in the [browser client 'Admin' pages](#).

**Concept**

This page shows the changes that were done to (part of) the configuration of your AE server. This info can serve regulatory requirements or can be useful to troubleshoot an issue.



**Note:** IDP configuration changes triggered by a backup-restore and IDP changes done outside the UI (example: by editing the XML) are not tracked and will not show up here.



**Note:** AE SaaS customers will not see the details for configuration changes on 'Esko managed' configuration items (for example: Esko changed Identity Providers on date/time).



**Note:** IDP Client secrets and passwords are never exposed here.

These configuration changes are logged in the database after a minute. There is no live update. Click  to refresh this page manually.

There is also a search field (searches on columns 'User' or 'Date').

In the [Configure tool](#), you can define how long this type of data should be kept in the database.

**Columns**

- **Date:** The date and time when the change was made.
- **User:** The user who made the change. This will be (local administrator) when changes were done using the [Server Config pages](#).
- **Category:** Identity providers. In this version of AE, this page shows changes to configuration in the page [Identity Providers](#).
- **Details:** A detailed description of what has changed.
- **Type:** Config change: In this version of AE, the only type is the one listing configuration changes.

**29.1.3. Server Admin section**

These are the same tools as in the [The AE Server ADMIN web page](#) on page 2009.

**29.2. The AE Server ADMIN web page**

---

The **Automation Engine Server Admin** web page allows you to administer and diagnose your (on-premises) server.



**Note:** In a SaaS setup, when your server is in a data center, this page is not available. This type of administration of your Automation Engine server is then done by Esko Platform Operations staff.

Open the Automation Engine Server Admin page by entering `http://<name of your server>:9999` in the address field of your browser.

To sign in to these pages, the user must be a member of the Windows Administrator group of this server.

A domain user can be specified as 'domain\user' or as 'user@domain'.

This tool offers 2 sections:

- the section **Server Admin** offers the features to manage your Automation Engine server. Its sub-pages are documented below.
- the section **Server Checks**. Also see below.



**Attention:** When you come to this page right after doing a fresh install where you choose a *Special* installation (one that does not install the default MS SQL Server Express), you will be prompted to first create all the Automation Engine databases. Alternatively, you can also continue using the "Embedded" database (for test-purposes only). Learn more below in [When No Databases were Installed Yet](#) on page 2026.

### 29.2.1. Status Overview

- **Server Status:**
  - Use the **Stop/Start Server** button to stop or start the Automation Engine server software. You will be asked to confirm. Starting or stopping the Automation Engine server software can take several minutes. This page will indicate the status during this process. You can refresh manually and visit other pages while it is processing.
  - **Activate Server** also restarts the software but adds extra processes. You will be asked to confirm. A window will describe this activation progress. We recommend to only use this when so advised by Esko specialists.
  - Click **Download Log Files** to save a ZIP file to your local computer. This file (aesrvlogs.zip) contains the main bgmd\* log files, many installation log files, etc.
- The pane below shows
  - the number of **Connected Clients** and **Executing Tasks**. See more details in the page [Server Activity](#) on page 2010.
  - the **Server version**. Learn more about the installed software in the page [About](#) on page 2031.
  - The server's **Current Role**. Learn more about Master and Assistant servers in the page [Server Setup](#) on page 2011.
- Click **Restart Web Server** to restart the Automation Engine web service. This web server is used for HTTP based integration with external systems and is also used to run these admin web pages. This page is automatically refreshed when the web server is restarted.

Click **Download Log Files** to save a ZIP file to your local computer containing the log files of the web server and of these **Server Admin** pages.



**Note:** Log files of client applications are not shown in **Server Admin** pages because they are executed on the client computer.

### 29.2.2. Server Activity



SERVER ACTIVITY		
<b>CONNECTED CLIENTS (2)</b>		
COMPUTER	USER	APPLICATION
10.31.148.226	kvdh	Automation Engine Pilot
10.31.148.226	wde@rdvmaedoc02	Automation Engine Browser Client
<b>EXECUTING TASKS (1)</b>		
TASK	USER	FILE
Export PDF Info	wde	giraffe.pdf

**Connected Clients and Executing Tasks:**

- In both topics, this info is updated live.
- When viewed on an Automation Engine Assistant, only the number of connected clients or tasks (on the master) is shown, no further details (note that it is not possible to sign in to an Assistant).

### 29.2.3. Server Setup

- The **Role** of an Automation Engine server can be '**Master**', '**Assistant**' or '**Idle**'.
- **Master:** The computer that runs the main server software. The AE software is installed and fully enabled (according its licensing).
- **Assistant:** A computer where AE software is installed but that only executes specific tasks when so requested by the Master server.



**Note:** An Assistant needs to be of the exact same software version as the Master (major version, minor version and the build number must match).



**Note:** Changing a server's role to Master will perform an 'activate server'.

- **Idle:** A computer where AE software is installed but where the 'server' service (BGMD) runs as 'Idle' (i.e. the software doesn't really do anything ; the term 'idle' refers more to its status than its role). There are 2 main use cases:
  - This is a computer that serves as a Central Resource server.

- Or it could be a server that should run the software but that encountered some problem to start it further up ; typically an issue with licensing.

Learn more below in [Server Roles](#) on page 2012.

- **Central Resource Server:**

By default, the Master server uses the locally installed resources.

When you open this page on the Master server, you can redirect these resources to another computer. To do this, just type the name of the other computer where these other resources are.



**Attention:** However, for performance reasons, Esko advises to keep these resources on the Master server.

These resources are distributed over these folders:

- bg\_data\_cms\_v010. Color engine database
- bg\_data\_custom\_v01. Various resources like action lists, layout templates, notification templates, CAD mappings, etc.
- bg\_data\_dgc\_v010. The Curve Pilot database: icpro files, dot gain curves, etc.
- bg\_data\_fonts\_v040. Central fonts repository.
- bg\_data\_ipldata\_v010. Ink planner data.
- bg\_data\_marks\_v010. Your SmartMarks.
- bg\_data\_screens\_v020. The Imaging Engine screens.



**Note:** You can not redirect only a selection of these resource folders.

## Server Roles

You can configure an Automation Engine server installation as Automation Engine **Master**, **Assistant** or as **Idle** (used as Central Resource server, storing color data, curves, fonts, etc).

These multi-server setups act as a set of co-operating servers to distribute the workload and provide recovery when one of them goes down. These configurations are all within one same LAN.

### Automation Engine standalone setup

A standalone Automation Engine server is the simplest setup. You have one server and that one is the Master.



**Note:** However, One same organization could have a configuration with more than one standalone server. In this setup,

- each system has its own set of resources (such as color engine data, DGC data, font data, custom data, marks data, ink planner data, task history database). Each system functions independently without sharing the workload.
- each system has its own local license management.
- you can create Containers on shares of other systems.

Standalone Master Server Setup

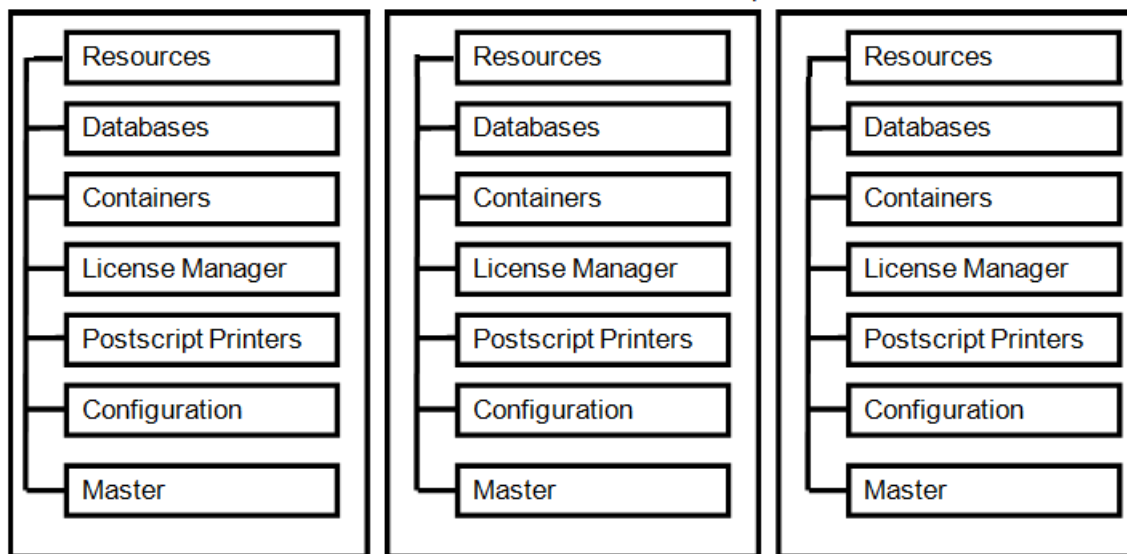

**Automation Engine server setup with Assistant system(s)**

This consists of an Automation Engine Master server and one or more Automation Engine Assistant systems. In this setup,

- the Assistants execute tasks. They use AE's central resource files from the Master.
- Automation Engine clients (Pilot, browser client) connect to the Master computer, not to the Assistants.
- the workload on these systems is allocated to the system with the smallest load, preferably another Assistant. If one of the Assistant systems goes down, it is automatically removed from the configuration and the other systems take over the workload.

If the Master system goes down, the complete configuration will be down. But after one of the Assistants has been promoted to Master, the system can be restarted. This is why a recent backup of the Master is always to be stored on another computer.

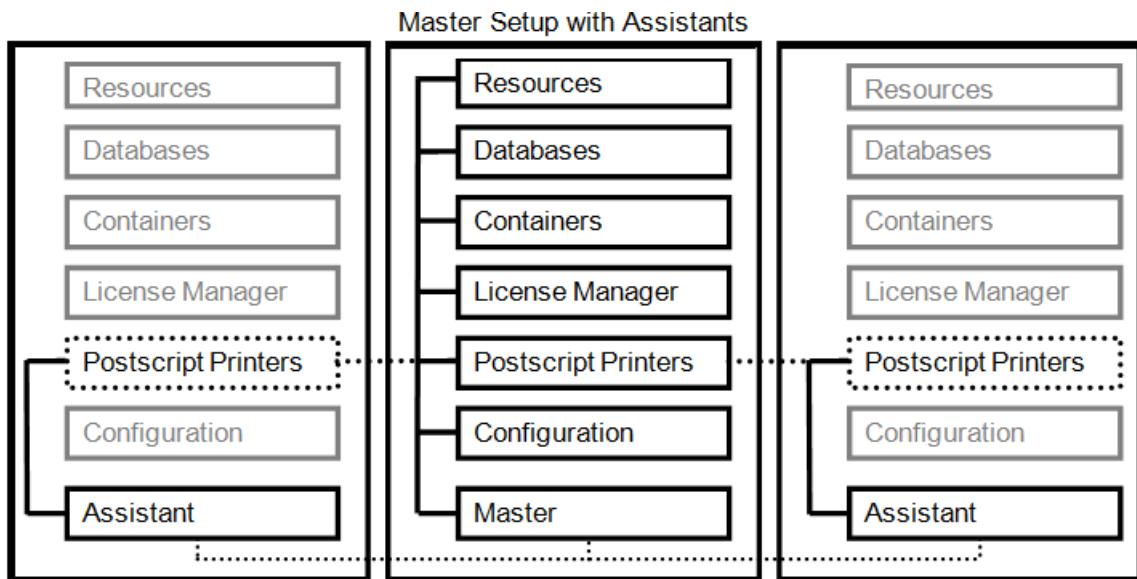

**Automation Engine server setup with Assistant system(s) and Central Resource server**

You can configure an Automation Engine Central Resource server (role: "Idle") which can be accessed when the Master goes down along with the Assistants. A Central Resource server can be set up for all the resources required to facilitate the take over of the Master role by one of the Assistant systems.

Master Setup with Assistants and Central Resource server (Idle)

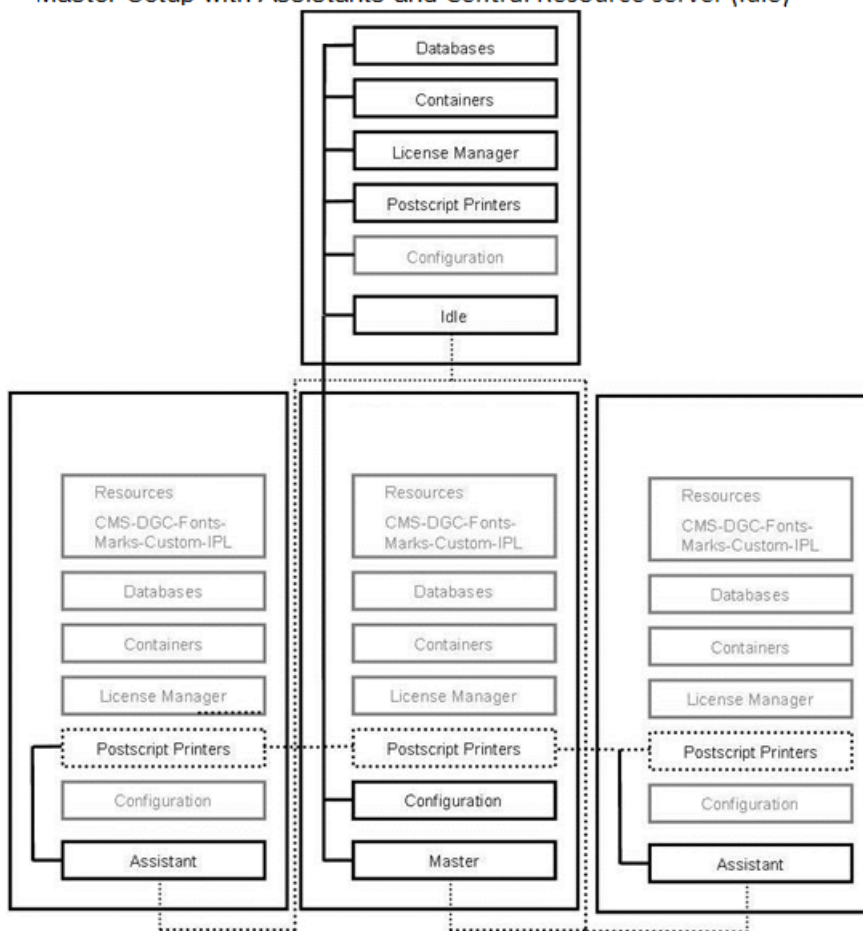

**Note:** When you use the **Print Task** to output on PostScript printers, you should define and configure the PostScript printers on all the systems (Master and Assistant).

We recommend installing the PostScript printers

- locally on the Master system (in Master-Assistant Setups)
- or locally on the Central Resource server (Central Resource server - Assistant server setups).

Configure them on the network so that you can access them on all other systems as network printer.

### 29.2.4. Processing Capabilities

What do you allow this server to do?



**Note:** When editing fields are disabled, click the lock icon top right to enable them. Depending on your current user rights, you may be asked to sign in again with a user who has privileges to make these changes.



**Note:** The settings can only be viewed or changed when the Automation Engine server is up and running.



**Note:**

- Settings can be changed when you unlock the page.
- When 1 or more settings are changed, they can be applied or reverted again to the original values. Applying is only possible when the new values are valid.
- When you lock the page without applying, the settings are automatically reverted.

**Tasks**

- **Server can run tasks:** Select this option to allow an AE Assistant server to execute tasks. When disabled, the Assistant will not execute any task.



**Important:** You can not disable this for a master server. This also means that this setting will be selected on your master server after an upgrade to 23.03 or higher.



**Note:** When changing this setting, it is not necessary to restart the Automation Engine server.

- **Limit Concurrent Inspecting:** If you use the [GlobalVision inspection tasks](#), indicate here how many you want to allow being executed at the same time. Warning messages tailored to your setup will be shown when you set this to more than 2.



**Note:** These tasks are run in a separate CPU queue named "CPU\_GV". Learn more in [Queue Monitor](#).

**Viewing Files**

- Select **Server can prepare and view files** to allow this server to run file streaming sessions for the Automation Engine Viewer.

This is also required to view files that were already prepared for viewing. In those cases the server might need to enable a deeper zoom than prepared for, i.e. with a resolution that is higher than the one of the prepared view data.



**Note:** In the server's Windows Task Manager, these processes are named **sdbserver.exe**.

- **Limit Concurrent Viewing.** This limit is important when your server also needs to run other tasks. Learn more about these concurrent viewing sessions, viewing technologies and their different behavior in [Intro, Technologies and Formats](#) on page 1077.



**Attention:** We strongly recommend that only experienced system administrators or Esko support staff modify this setting.

**Gang Run Printing**

- **Server can calculate layouts**

Select this option to allow this server to calculate layouts for [Gang Run Printing](#).

The Gang Run Printing tools use a nesting software that starts processes that calculate optimal nested layouts (PDFPLA) for Gang Run jobs. It does this for one particular substrate queue at the time. These calculations can be time consuming. You could have these done on an Assistant for example.

- **Limit Concurrent Calculating**

You here define how many layouts the substrate queues are allowed to calculate simultaneously.



**Attention:** The default maximum number is 1. Increasing this number may lead to the Automation Engine server slowing down.

### Task Queues



**Note:** Below settings are only available on a Master server.

- **Dynamic Mode.**

Dynamic mode is not really about load balancing (across the master and its assistants). This mode provides an automatic throttling down to prevent the server from choking under heavy load. .

The maximum amount of tasks that will run concurrently is still defined by the licensed channels. However the server will throttle down (use less concurrent tasks) when there are insufficient resources available on the server (and its assistants).

This mode so prevents becoming overloaded ; it results in a more stable system and is therefore the recommended mode.

When dynamic mode is enabled, the following applies:

- Task queue settings are no longer relevant and are not available.
- The number of reserved channels is also not relevant and is not available,
- The number of processing channels is equal to the number of licensed channels (and will be shown as such

- **CPU Queue Maximum and CPU LIGHT Queue Maximum:**

When the dynamic mode is not selected (the "static" mode), you have some control over these 2 [CPU queues](#). Their minimum value is 1. Changed values will be only applied after you click **Apply**.

The number you enter here is the maximum amount of regular tasks that will be executed concurrently on this CPU queue. In a cluster setup, it will be that value MINUS the number of reserved channels (learn more below).

- The maximum value for the CPU queue = the number of *licensed* channels (in a cluster setup minus the number of reserved channels). The number of processing channels will be set equal to this CPU queue maximum.
- The maximum value for the CPU\_LIGHT queue = the number of *processing* channels (in a cluster setup minus the number of reserved channels). The maximum recommended value is 5. When set higher, a warning will be shown.



**Note:** Error messages will be shown when you set non supported values.



**Note:** The queue for the GlobalVision Inspection tasks is not part of this function. Learn more in [Limit Concurrent Inspecting](#).

**Cluster Setup**

- **Processing Channels:** This field shows you the number of processing channels on this master server.
  - If it is equal to the number of licensed channels, only 1 value is shown (" x licensed channels"). This is always the case when dynamic mode is enabled.
  - If it is less than the number of licensed channels, both values are shown ("y of x licensed channels"), together with a message that the number has been reduced to meet the system's capabilities.
  - Remark that the number of processing channels is equal to the value in **CPU queue maximum**.
- **Reserved Channels:** To help avoid delayed responses, you can here reserve a number of channels of the CPU queue to be used by a synchronous [Web Service Access Point](#).



**Note:** It is not possible to set the Reserved Channels when the task queues are set to Dynamic Mode.

**29.2.5. System Account**

Automation Engine needs a so called 'system account'. This system account is a Windows user account that is used to run Automation Engine's services (for example BGMD) and to connect to other network components (for example to access files on a remote file server).

When Automation Engine is first installed, a user is asked to define what the system account will be. This can either be

- a new user account created by the installer:
 

Enter a user name and password. Note that the password for this user must meet the complexity requirements of the operating system it is installed on.
- an existing user account:
 

Enter the credentials of a local or domain user account that has administrative privileges on the computer it is installed on.

Find more details in the chapter 'Pre-Install IT requirements', on the page [Automation Engine System Account](#) on page 1964.

Esko strongly advises to set and manage a secure custom password for this account.

**Changing the Password of the System Account of Automation Engine**



**Warning:** When your initial Automation Engine installation was a version before version 20, do check if you are still using a default password that was till then still established during a new installation. For IT security reasons, Esko strongly advises to change this password to a different one.

Type in the **Old Password**, then the **New Password** and the **Confirm** your new password.



**Note:** This function is available both on an Automation Engine Master and an Automation Engine Assistant. However, if you change the password on an Assistant, the change will not be synchronized to any other Automation engine Master/Assistant.



### Changing the System Account of Automation Engine

You can change the system account from the default account BGSYSTEM to another existing Windows user. This user should be a member of the Windows Administrators group on the Automation Engine master server computer.

You can use either a local or domain user account.



**Note:** In a Master/Assistant setup, when you change the system account to a local user on the Master server, changing the user on the Assistant will fail because the local Master user can not be known on the Assistant. You then need to use a domain user or manually change the Assistant system account.



**Note:** Modifying the system account via this tool will modify the service account of both the Automation Engine server service (BGMD) and of the Automation Engine web services

- If you have configured a Container or resource folder on a computer that does not have the *Role* of Master, Assistant or Central Resource server, you will, on that computer, have to modify the system account manually.
- If you have configured an Imaging Engine on a computer that does not have the *Role* of Master, Assistant or Central Resource server, then the modification of the system account will be pushed to the Imaging Engine computer.



**Important:** This requires that the new user was added as a member of the Windows Administrators group of the Imaging Engine host. When that is done, also a stop/start of Imaging Engine is required (see **Automation Engine Pilot > Configure > Imaging Engine**).

### 29.2.6. Maintenance

Database indexes are used to quickly locate data without having to search every row in a database table every time a database table is accessed.

Heavily fragmented indexes can cause Automation Engine to respond slowly. You can remedy index fragmentation by reorganizing or rebuilding a database index.

Click on **Start Maintenance Now**, select the databases you want to rebuild and click **OK**.

Please mind the dialog's disclaimer at the bottom.

Start Maintenance Now ✕

---

Rebuild database indexes of

- Jobs
- Tasks
- Task History
- JDF
- Devices
- Gang Run Printing
- Application Server
- Printing Conditions

Please only do this when production is low or down and avoid making a backup at the same time.  
Database performance could be affected while rebuilding indexes.

It might take several minutes to complete the maintenance.

Close
Start



**Note:** The **Application Server** database index cannot be rebuild when the database is not running.

### Scheduling Maintenance

Click **Add Maintenance Schedule** to schedule this maintenance to happen later.

Select the databases, frequency and start time. Click **OK**. Please mind the dialog's disclaimer.

## 29.2.7. Backup

A backup is a folder containing a backup report, subfolders, ZIP and other files. The actual content depends on the chosen backup mode.

A backup does not include job data files and does not include any Automation Engine software.

A full backup contains your server's **Configuration, Resources** and **Databases**.

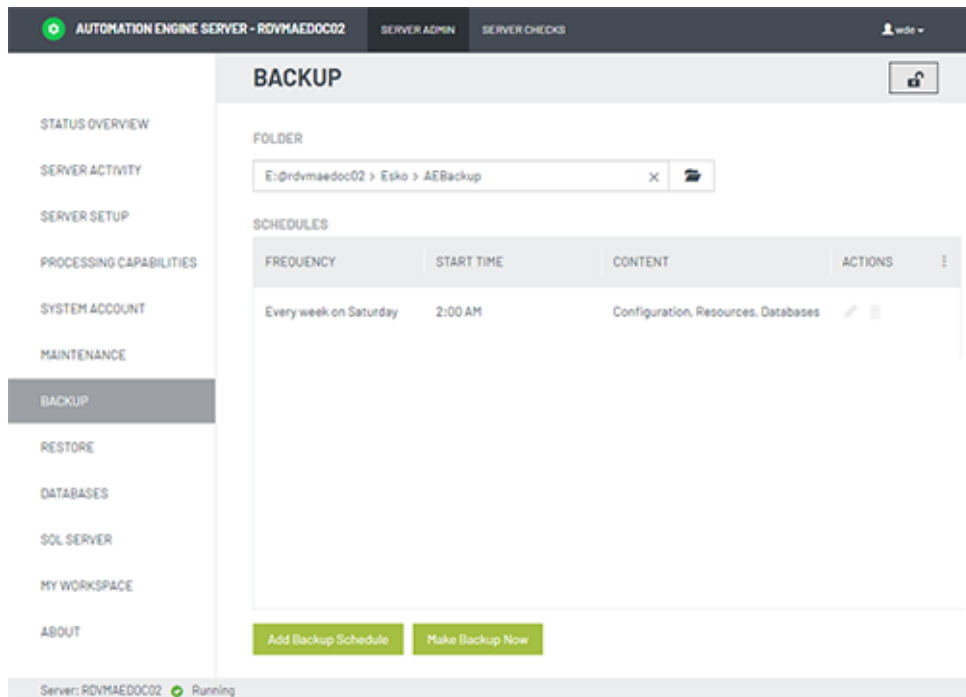

• **Folder:**

Define the root folder where backups should be created. Each backup is then created in a subfolder named Backup\_\_yyyy-MM-dd-HHMM. A full backup is named FullBackup\_\_...



**Tip:** It is always a good idea to write the backup on a different computer than where the data originally are. You can of course keep a local path as destination and then for example copy the backup data onto an external disk or medium.



**Tip:** You can use a UNC path as location. Just make sure that the corresponding share is accessible.

• **Schedules:**

You can schedule a backup or run it instantly.



**Note:** Yes you can make a backup while Automation Engine is running. You can also make backups when the server software is not running.

- When choosing **Make Backup Now**, you will first be asked which data set you want.
  - The **Configuration** is always included. These are the task tickets, workflows, SmartNames, configuration settings, etc. In detail:
    - A backup **report**
      - a text file with details of all folders and file names that have been backed up and any warnings or errors were encountered during backup process.
    - The folder **Users**, with user info regarding the BG and Database systems.

- The folder **bg\_data\_fastserver\_v100**, with all the Config Server (CFS) information, including:
  - SmartNames
  - Containers
  - Registered RIPs/Imaging Engines
  - Registered Devices (CDI, Kongsberg)
  - 'TaskManager' queues
  - Tickets/Workflows
  - Hot Folders
  - Scripts for ScriptRunner
  - Templates for Notification
  - Information about users belonging to the local groups BGUsers and BGAdmin.
- The folder **bg\_data\_custom\_v010**, with info of all its non-empty subfolders, except 'dat \bs'.
- **Resources:** This includes the
  - DGC related files
  - CMS related files (writable files)
  - Font related files
  - Ink planner related files
  - Marks related files
  - Screens related files. These are (only) the files in the folder **bg\_data\_screens\_v020** that match any of these patterns:
    - files that have the characters `hd` anywhere in their name or extension
    - files that have the characters `scr` anywhere in their name or extension
    - files that have the characters `crs` anywhere in their name or extension.
- **Databases:** A backup of each database used by Automation Engine: Devices, Tasks, JDF, Gang Run Printing, Task History, Application Server, Jobs, Printing Conditions. These databases includes these items:
  - AE Jobs
  - To Do list items
  - Access Points
  - Tasks / Task History
  - Gang Run Queues / Orders / Sheets
  - Plate Merger Queues / Merged Plates / Press Plates
  - Customers
  - Products
  - and some more



**Note:** A backup of the databases is also called a **Restore Point**. When you plan an upgrade, make sure to consult the chapter with the [Installation Guide](#) on page 1982.

- Click **Add Backup Schedule** to automate this. You can define the **Frequency**, what to backup and also how many backups you want to keep.



**Important:** Backups of large databases will also be large. Use the setting **Keep only last 'x' backups** to avoid filling up the disk where you keep the backups.

To restore a backup, see the page [Restore](#) on page 2023 .

### 29.2.8. Restore

You can only restore a backup when the Automation Engine server software is stopped.



**Note:** A backup can be restored on an Automation Engine master server with the same or higher version as the master server where the backup was made from.

Select a backup from the **Backup History** and click the action .

The **Restore Backup** dialog shows details of that backup.

In **Option**, select what you want to restore:

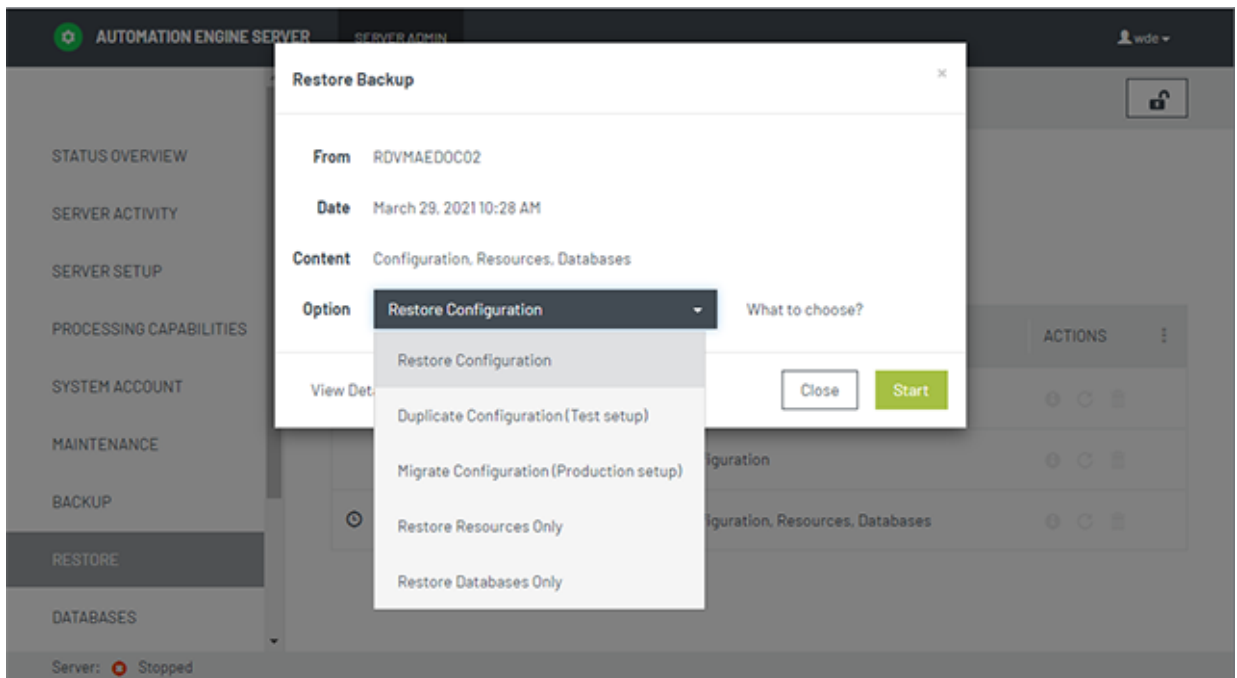

- **Restore Configuration:** This restores everything from the selected backup. This is used to go back in time, probably to correct some mistakes, for example when you deleted too many workflow tickets.



**Note:** This option is only valid when you restore on the same server as from where the backup was taken.

- **Duplicate Configuration (Test):** This is used when building test setups, for example to test pre-release software or to set up a shadow production server. The goal here is to obtain an Automation Engine master that is very similar as the production server (same Tickets/Workflows, same SmartNames, same Users) but that does not interfere with the production server (different Containers, different Hot folders, different Databases (Jobs, Access Points ...), different Resources)



**Attention:**

- This function **does not restore**: Central Resources, Databases, Container setups, Customers, Hot Folders, etc. These data are not taken over from the backup and are so left untouched. Mind that the data inside Containers was not part of the backup.
- This function **always restores** (if available in the backup): (workflow) Tickets, SmartNames, Users, DFS information and all data related to the folder `bg_data_custom_v010`.



**Note:** To build a test setup, you first need to install a full Automation Engine server on the testing computer. This will also require a separate set of licenses. And then you can use this mode to restore the configuration on that testing computer.



**Note:** When restoring on a server with a license for AE SaaS, Windows Users are not restored.

- **Migrate Configuration (Production):** This is used when you plan to move your server to another computer or when you upgrade onto a separate computer.



**Note:** To do this, you first need to install a full Automation Engine server on the new computer. You then use this option to restore the old/previous production settings onto the new computer.

You can also use this option to give the Master's configuration to an Assistant when the Master goes down.



**Note:** The Master backup can be found on the Assistant computer (by default on `C:\Esko\AEBBackup`).



**Note:** When restoring on a server with a license for AE SaaS, Windows Users are not restored.

- **Restore Databases Only:** Select which databases you want to restore: **Jobs** (also includes Customers, Access Points...), **Tasks**, **Task History**, **JDF**, **Devices**, **Gang Run Printing**, **Application Server** (page workflows), **Printing Conditions** and **WFMgr** (internal).
- **Restore Resources Only:** Select which resources you want to restore: **DGCs**, **Marks**, **Fonts**, **CMS**, **Screens**, **Custom**.
- **Migration Configuration (From on-premises to SaaS):** (SaaS only).

When migrating your on-premises AE server to its SaaS setup, it is possible to restore the configuration of the on-premises server onto the SaaS server. The Server Admin - Restore function on a SaaS server offers an extra option named **Migration Configuration (From on-premises to SaaS)**.

Typical for this one is that it will **not restore any settings related to users and user groups**. This is advised to avoid overruling any already created users and to avoid creating users with too weak passwords, a security requirement on a SaaS server.

### 29.2.9. Databases

In the **Databases** page you can manage all databases that are on any accessible **SQL server** in your network. Depending on the permissions on the selected SQL **Instance**, you can:

- View the SQL server status.
- View the properties and status for each database.
- Backup or Restore databases.
- Repair databases (for example to repair access rights.)
- Move databases.
- Create or remove databases.



**Note:** Even when you are signed in to the **Server Admin** pages, you also need to log in to the SQL Server instance separately. For example via the user *sa*.

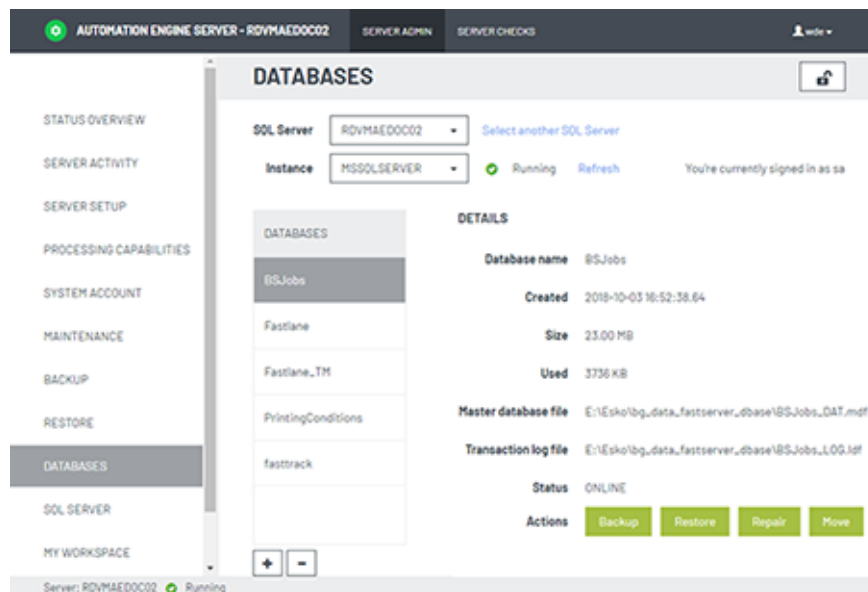

**Note:** When you use **Gang Run Printing**, it is possible to have a setup where this mode uses its own database, separated from the BSJobs database. You can then see it here listed as a separate database named GangRunPrinting.

The database **Status** can be any of these:

- **Online:** The SQL Server instance where the server database is located is running. This also implies that the user name and password used to login to the SQL Server instance are correct. The server database is online and available for access.

- **Not Accessible:** The SQL Server instance where the server database is located is running. Valid credentials (user name and password) are used. But the server database on the SQL Server instance is not accessible.
- **Not Found:** The SQL Server instance where the server database should be located is running and the credentials used to login to the SQL Server instance are valid. But the server database could not be found on the SQL Server instance.
- **Login Failed:** The SQL Server instance where the server database should be located is running. The server database is not available because the credentials used to login to the SQL Server instance are invalid.
- **Offline:** The server database is not available because the SQL Server instance where it is located is currently not running.
- **Unknown:** The status of the server database on the SQL Server instance is unknown.

### Creating a Database

These are cases when this tool is useful:

- Some customers want to run the Automation Engine databases on an own full SQL Server that they are already using. They then use this tool to create the necessary databases. It also creates the required users and sets the required user rights.
- When your (default) SQL Server Express edition is having trouble with one or more too large databases, Esko advises to upgrade to a full SQL Server. In case you do not do this, it is possible to use this tool to create multiple smaller databases. For example customers who heavily use both the Jobs tool and the Gang Run Printing tool. In this case they can create an extra database for the gang run printing and indicate that one in **Configure > Automation Engine Database**.



**Note:** This function is available both on an Automation Engine Master and an Assistant.

Follow these steps to create a database for Automation Engine:

1. Click on **+** (below left) to open the **Create database** dialog.
2. Fill in a **Database name** that is currently not used.
3. In **Use data**, choose which database you want to create: A new empty database (**No (empty database)**) or **From a backup** or **From existing database files**.
4. When they do not appear automatically, enter the location and the file name for the **Master database file** and the **Transaction log file**. Alternatively, **Browse** to set a specific location for these files.



**Note:** The file names can be either a local or a UNC path.



**Note:** If the selected SQL Server is not the local SQL Server, then the browse button will be disabled. In such cases, fill in the UNC path.

5. Click **OK** to create the database.

### When No Databases were Installed Yet

When you first come to the **Server Admin** page after doing a fresh install where you choose a *Special* installation (one that does not install the default MS SQL Server Express), you will be prompted to first create all the required Automation Engine databases.



Creating the databases is what you want when you decided to use a MS (full) SQL Server from the beginning. Alternatively, in stead of creating new databases, you can here also choose to continue using the "embedded" databases (for test-purposes only). Both cases are described below:

In the case as described above, the **Server Admin** page will first present you the **Create Automation Engine Databases** dialog:

### Creating new databases on a MS SQL Server

- Select the (remote) **SQL Server** and **Instance** where you want to create the Automation Engine databases.
  - When the SQL Server you want to use is not in the list, you can add it by clicking '**Select another SQL Server**'. In the dialog, fill in a valid server and click **OK**.
  - When the running instances on the selected SQL Server can not be detected (because for example the SQL Server Browser is not running on that host), you can then still choose an instance by typing its port number in the **Instance** field.
- Provide a **user name** and **password** with sufficient privileges, typically the user 'sa'.
- Fill in the local path to the **folder** on the (remote) SQL Server host in which the database files should be stored.
- Click **Create** to start the creation process. When the creation process was successful, you will be asked to restart the server.

### Continue using the embedded databases

Click **Continue using embedded databases** to skip creating databases.

Choose this option

- when you want a custom setup, for example one where the databases are spread out over multiple instances. To configure such a custom setup, go to the [Automation Engine Database](#) section in the Pilot's [Configure](#) tool.
- when Esko support staff advises this. For example as part of a solution for a database problem.

In both cases, you will see a warning that embedded databases are not at all fit to use in production environment. Learn more in the page describing options in the **Configure** panel: [Generic setting \(Setup tab\): DBMS Type](#) on page 175.

Choosing this option still allows you to cancel.

### Deleting a Database

You can only delete a database if it is not used by Automation Engine. If it is running, trying to delete it will trigger a warning.

1. Select a database from the list and click the - button (below left).
2. In the confirmation dialog, choose either or both of the options:
  - **Delete database files from disk**
  - **Close existing connections**
3. Click **OK** to confirm.

### Database Backup

- Select a database and click **Backup**. The **Backup database** dialog will open.
- Enter the location and the file name for the **Backup file** or browse to choose an existing backup file.



**Note:** The file names can be either a local or UNC path. If the selected SQL Server is not the local SQL Server, the browse icon will be disabled. In such cases, fill in the UNC path.

- Click **OK**.

If the selected SQL Server does not have access to the UNC path you entered, you will get this warning: "Backup file for database X could not be created. Please make sure the path for the backup file is correct."

You can ensure access to the UNC path (share) by following this procedure:

1. In Windows Explorer, right-click the shared folder and then click **Properties**.
2. Select the tab **Security**.
3. Click **Advanced**. The **Advanced Security Settings** dialog opens.
4. Under the **Permissions** tab, click **Change Permissions**.
5. Click **Add**.
6. Click **Object Types** and make sure the **Computers** check-box is checked. Click **OK**.
7. In the text field, enter the name of the SQL Server computer name for which you want to add permissions. Click **Check Names**. Click **OK**. The **Permission Entry** dialog opens.
8. Make sure the **Allow** check-box next to **Create files / write data** is checked. Click **OK**.
9. Click **OK** and close the open dialogs.

### Restoring a Database

Select the database and click **Restore**. Browse to the location and file name and click **OK**.

When you want to restore a database that does not exist (any more) in the list of SQL Server Instance databases, then click on + to create a database from a backup file or from existing database files.

Learn more in [Creating a Database](#) on page 2026.



**Note:** If the database you are trying to restore is used by Automation Engine and the Automation Engine server is running, it will not be possible to restore the database and you will get a warning.

### Moving or Renaming a Database

1. Select the database from the list and click **Move**. The **Move database** dialog will open.
2. Enter the (new) location and the (new) file name for the **Master database file** and for the **Transaction log file** or browse to select to them.



**Note:** The file names can be either a local or UNC path. If the selected SQL Server is not the local SQL Server, the browse button will be disabled. In such cases, fill in the UNC path.

3. Decide if you want to **Close existing connections**.
4. Click **OK** to move/rename the database.

## 29.2.10. SQL Server

This page allows you to manage SQL Server instances.

The screenshot shows a web-based interface for managing SQL Server instances. At the top, there are tabs for 'SERVER ADMIN' and 'SERVER CHECKS'. The main content area is titled 'SQL SERVER' and includes a lock icon. Below the title, there are dropdown menus for 'SQL Server' (set to RDVMAEDOC02) and 'Instance' (set to MSSQLSERVER). A 'Stop the SQL Server' button is visible. The server status is shown as 'Running'. A sidebar on the left lists various management tasks like 'STATUS OVERVIEW', 'SERVER ACTIVITY', 'SERVER SETUP', 'PROCESSING CAPABILITIES', 'SYSTEM ACCOUNT', 'MAINTENANCE', 'BACKUP', 'RESTORE', 'DATABASES', and 'SQL SERVER'. At the bottom, a status bar indicates 'Server: RDVMAEDOC02 Running'.



**Note:** When the SQL Server Database is installed on the same system as the Automation Engine server, the option **SA credentials** allows to check if the SA credentials used by Automation Engine are still in sync with that database. This option is not shown for other SQL databases. It is also not shown until you are logged in to the SQL server with the right credentials (click  to do so).

When the **Check** detects that the credentials are not in sync, a dialog asks to enter the current password for the SA user. Mind that this dialog does not allow you to specify a new password for SA, only to update the stored SA password used by AE.

### How to Log in to an SQL Server Instance

- Select an SQL Server from the list of all SQL Servers that could be detected in your local network. When there is one, the local SQL Server will be selected as default.
- To choose one that is not in the list, click **Select another SQL Server**, enter the name of the SQL Server and click **OK**.

You can see the list of SQL Server Instances and their statuses beneath the SQL Server list. You can select the Server Instance on which you want to manage the databases.



**Note:** When the SQL Server Browser service is not running or when your access is blocked to the Server Service, the status of the Instance will be unknown.



**Note:** When the list of SQL Server Instances is not available, you can select an SQL Server Instance by entering its port number. The port number of the default SQL Server Instance will already be filled in.

- After selecting the SQL Server Instance, click the lock  and enter your credentials to login. You have to login to an SQL Server Instance to be able to manage its databases.



**Note:** All SQL instances configured with Automation Engine have two users by default: `sa` and `admin`. The `sa` user has all permissions to manage databases. The `admin` user has a limited set of permissions, you may get warnings while performing certain database actions.

- You can log out from the SQL Server Instance by clicking on the lock .
- You can view the databases installed on an SQL Server Instance by selecting it and logging in. The list of databases will load after logging in. Detailed database information will be available to the right of the selected database.

### FAQ on SQL Server Instances

#### How to Start or Stop an SQL Server Instance?

Select the SQL Server Instance and click on **Start / Stop the server**.



**Note:** You are not required to login to the SQL Server Instance to start or stop the Server.

### How to View the Properties of a SQL Server Instance?

The properties of an SQL Server Instance are shown automatically after you successfully logged in. Learn more in [How to Log in to an SQL Server Instance](#) on page 2030.

### How to Modify the Maximum Memory of an SQL Server Instance?

Click the **Modify** link next to the **Max. physical memory**. In the dialog, enter a value and click **OK**.

### How to View SQL Server Logs?

Click the **Show** link next to **SQL Server logs**. You can see the SQL Server logs in the following dialog.



**Note:** When you have limited permissions, you will get a warning when you attempt to view the SQL Server logs.

## 29.2.11. My Workspace

The only item on this page is to define the **Upload Folder** for the browser client's workspace "My Workspace".

When users drop files on a drop zone in My Workspace, they are first uploaded to this folder and from there processed by the selected workflow. Unless the user works in a Job context, then the dropped files end up on the root folder of the Job Folder.



**Note:** Each upload session to a drop zone creates a temporary sub folder in this upload folder.



**Attention:** When the Drop File page is used a lot, make sure that these sub folders in this upload folder get cleaned up. All related temp subfolders and files will be deleted automatically when the tasks that created them are deleted (or moved to Task History).



**Note:** A changed setting requires that you click **Apply!**



**Note:** Learn about My Workspace in the chapter [Browser Client Workspaces](#) on page 886.

## 29.2.12. About

The **About** page shows detailed information about the Automation Engine server software version, updates and hotfixes that were installed on this server.

» ABOUT AUTOMATION ENGINE

---

Server version	14.1.0 - build 94
Installed on	Sep 15, 2014 4:26 PM

---

Hotfixes	<table border="1"> <thead> <tr> <th>Hotfix</th> <th>Installed on</th> </tr> </thead> <tbody> <tr> <td>Hotfix 1410001 for Automation Engine 14.1.0</td> <td><a href="#">Info</a> Sep 16, 2014 12:12 PM</td> </tr> </tbody> </table>	Hotfix	Installed on	Hotfix 1410001 for Automation Engine 14.1.0	<a href="#">Info</a> Sep 16, 2014 12:12 PM
	Hotfix	Installed on			
Hotfix 1410001 for Automation Engine 14.1.0	<a href="#">Info</a> Sep 16, 2014 12:12 PM				

---

History	<table border="1"> <thead> <tr> <th>Action</th> <th>Date</th> </tr> </thead> <tbody> <tr> <td>Installed Hotfix 1410001 for Automation Engine 14.1.0</td> <td><a href="#">Info</a> Sep 16, 2014 12:12 PM</td> </tr> <tr> <td>Installed Automation Engine 14.1.0 - build 94</td> <td>Sep 15, 2014 4:26 PM</td> </tr> </tbody> </table>	Action	Date	Installed Hotfix 1410001 for Automation Engine 14.1.0	<a href="#">Info</a> Sep 16, 2014 12:12 PM	Installed Automation Engine 14.1.0 - build 94	Sep 15, 2014 4:26 PM
	Action	Date					
Installed Hotfix 1410001 for Automation Engine 14.1.0	<a href="#">Info</a> Sep 16, 2014 12:12 PM						
Installed Automation Engine 14.1.0 - build 94	Sep 15, 2014 4:26 PM						

To learn more details about a hotfix, click its **Info** button. You will see its name, a description what it is for, on what version it should be installed and when it was created.

### 29.2.13. Server Checks

#### Databases Check

The **Databases** page checks



- if the database system of the database is up and running.
- if the database is online and accessible for the Automation Engine server.
- if the size of the database is not nearing its size limit.

Click the **Info** icon to see some more information like the database file name and the SQL Server and/or SQL Server instance where the database is located (if the database system is Microsoft SQL Server).

This function is available on the AE master server only.



**Note:** These databases are those that are configured in the Configure tool, in [Automation Engine Databases](#). Some of them depend on licenses.

 AUTOMATION ENGINE SERVER - RDVMAEDOC02    SERVER ADMIN    SERVER CHECKS     wde

### DATABASES CHECK

DATABASES CHECK

CONTAINERS CHECK

DISKS CHECK

NETWORK CHECK

HEALTH CHECK



SCHEDULED CHECKS

SETTINGS

STATUS	DATABASE	DATABASE SYSTEM	DETAILS	ACTIONS
	Jobs	Microsoft SQL Server	Database is online and accessible.	<span>Info</span>
	Tasks	Microsoft SQL Server	Database is online and accessible.	
	Task History	Microsoft SQL Server	Database is online and accessible.	
	JDF	Microsoft SQL Server	Database is online and accessible.	
	Devices	Microsoft SQL Server	Database is online and accessible.	
	Gang Run Printing	Microsoft SQL Server	Database is online and accessible.	
	Application Server	Microsoft SQL Server	Database is online and accessible.	
	Printing Conditions	Microsoft SQL Server	Database is online and accessible.	

Check Again

The **Status** of the database can be one of these:

-  The database is online and accessible.
-  The database is online and accessible, but there are one or more warnings (for example the database is near its size limit or the connection speed is not sufficient).



**Note:** The connection speed is checked by this small test:

1. Start the timing
2. Connect to the specific database
3. Retrieve some data (db query of "select @@Version")
4. Stop the timing.

This test is repeated 10 times, and then an average is calculated. When that average speed exceeds 100 ms, the status is a warning.

-  The database is not online or is not accessible (for example no connection could be made to the database system, or the login failed).



**Note:** Before v21.11, database checks could return an error saying that the 'user 'admin' will not be able to properly create and manage database tables'. The error message add that the user needs to check if the user 'admin' is member of the 'necessary database roles'. Since v21.11 the user only needs to have the database role 'db\_owner'.

-  The status of the database is unknown. This is the case when the DBMS type of your Application Server database is Oracle or when any of the other databases is an Embedded database. There are no tests available for these two types.



**Note:** When the Automation Engine server is not running, you can still check the status of its databases. In this case however, the **Database System** field will be empty.

### Containers Check

The **Containers** page checks the status of each container configured on this Automation Engine server.

Status	Name	Details
	ExampleJobContainer@loppem	Container "ExampleJobContainer@loppem" is online and accessible (157.3 GB available of 465.7 GB).
	ExampleJobContainer@leupegem	Container "ExampleJobContainer@leupegem" is online and accessible (193.6 GB available of 465.7 GB).
	DeskPackContainer@eaw12dd320	Container "DeskPackContainer@eaw12dd320" is online and accessible (217.9 GB available of 465.7 GB).
	gdm_container@homer	Container "gdm_container@homer" on "\homer\gdm_container" is nearly full (82.7 GB available of 350 GB).
	ExampleJobContainer@twister	Could not connect to Container "ExampleJobContainer@twister" on "file://twister/ExampleJobContainer". Please contact your IT administrator.

**CHECK AGAIN**

This page checks

- if the container is online and accessible for the Automation Engine server.
- if the used disk space of the disk where the container is located is not getting too high. The percentage of used disk space at which you get a warning or an error can be set in the [Settings](#) page.

This function is available on the AE master server only.

### Disks Check

The **Disks** page checks and shows detailed information about the disks where the Automation Engine system folders are located.

These disks are checked :

- Installation disk (disk containing %bg\_prog\_fastserver\_vxxx%, where xxx stands for the version of AE )
- custom folder disk (disk containing %bg\_data\_custom\_v010% )
- temporary folder disk (disk containing %bg\_tmp% )
- backup folder disk (disk containing the Automation Engine backups )

Status	Name	Details
	Installation Folder Disk	The disk where the installation folder "C:\Dev\AE14.1\sr\prog" is located is accessible (169 GB available of 465.7 GB).
	Custom Folder Disk	The disk where the custom folder "C:\Esko\bg_data_custom_v010" is located is accessible (169 GB available of 465.7 GB).
	Temporary Folder Disk	The disk where the temporary folder "C:\Esko\bg_data_fastserver_v100\tmp" is located has less than 20 GB of free disk space (14.9 GB available of 465.7 GB).
	Backup Folder Disk	The disk where the backup folder "C:\Esko\AEBackup" is located has less than 5 GB of free disk space (3.7 GB available of 465.7 GB).

**CHECK AGAIN**



This page checks:

- If the disk where the system folder is located is accessible to the Server.
- If the free disk space of the disk where the system folder is located is not getting too low.
  - When the free disk space is less than 20 GB, the check will show a warning.
  - When the free disk space is less than 5 GB, the check will show an error. Also, all task queues will be stopped automatically. Learn more in [Queue Monitor](#) on page 169.

This function is available on the AE master server only.

## Network Check

The **Network** page checks and shows detailed information about network connections of the Automation Engine server, including those to external systems like the **License Server**, **WebCenter Sites** and **Devices**.

General		
Status	Name	Details
●	Online Help	Online help is available at <a href="http://help.esko.com/">http://help.esko.com/</a> .
●	DNS	OK
●	License Server	Connection to license server "licman3:27000" OK.

WebCenter Sites		
Status	Name	Details
●	rdvmaewcr01	WebCenter Site "rdvmaewcr01" is online and accessible.
●	ikbestaniet	The server "ikbestaniet" does not have a public IPv4 address. Please check its network settings or contact your IT administrator.

Devices		
Status	Name	Details
●	esko-gen8-1	Digital Press "esko-gen8-1" on "esko-gen8-1" using port "8088" is online and accessible.
●	ScreenedOutput1	Could not connect to the Device "ScreenedOutput1" on "cssuite12a33" using port "3020". Verify that this Device is running and accessible and that you entered the correct information in Configure.
●	CDI1	Could not connect to the Device "CDI1" on "cssuite12a1" using port "3100". Verify that this Device is running and accessible and that you entered the correct information in Configure.

**CHECK AGAIN**

The network checks are grouped into categories:





- **General:** This category checks
  - if the Automation Engine server can connect to the **Online Help** (<http://help.esko.com>).
  - if the **DNS** settings are configured correctly (does the server name of this server computer match with what the DNS returns to other systems when they try to access it).
  - if the **License Server** can be reached (in case of failure, basic network tests are done to verify DNS configuration and TCP/IP connectivity).
  - if the **Assistant Server(s)** can be reached (in case of failure, basic network tests are done to verify DNS configuration and TCP/IP connectivity).
- **WebCenter Sites:** This category checks the network connection between the Automation Engine server and the configured [WebCenter sites](#).

- **Esko Cloud.** Shows the status of the connectivity to your Esko Cloud Connections. Learn more in [Sharing to Collaborate with other AE servers](#) on page 1685.
- **RIPs:** The connection with configured Imaging Engines or FlexRips.
- **Digital Presses:** The connection with configured [digital presses](#).
- **Devices:** The connection with configured [Devices](#) ([CDI devices](#) or [Kongsberg tables](#)).
- **Workflow Servers:** The connection between the Automation Engine server and legacy workflow servers [Nexus](#) or [Odystar](#), which are used by the 'Send to ...tasks' (by now outdated tasks).

If there are no network checks available or applicable for a certain category, then that category will not be shown, except for the **General** category, which is always shown.



This function is available on the AE master server only.

### Possible Statuses

-  The network test succeeded.
-  The network test succeeded, but there are one or more warnings.
-  The network test failed.
-  The network test was not applicable or was skipped.

### Health Check

These three categories check the health of your server computer: **Processor Cores, Memory and Tasks.**

Status	Name	Details
	Processor Cores	The number of processor cores is sufficient.
	Memory	The amount of memory in the cluster available for running tasks (3.5 GB of 8 GB) is not sufficient. There should be at least 4 GB available. Please consider reducing the number of file streaming sessions and/or gang run printing sessions or consider upgrading your cluster.
	Tasks	The Tasks database contains 590 tasks of which 94 tasks are older than 6 months. Please consider adding cleanup rules for the Tasks database in Configure.

**CHECK AGAIN**

This function is available on the AE master server only.

### Processor Cores

The check determines if sufficient processor cores are present for the current Automation Engine setup.

For each Automation Engine server (master and assistants):

- The number of processor cores is calculated that are required to run the configured number of file streaming sessions (the **Viewer**) and **Gang Run Printing** sessions.
  - **2 file streaming sessions require 1 processor core.** If the number of file streaming sessions is not even, an extra processor core is required.
  - **1 gang run printing session requires 1 processor core.**

- Based on this calculation, if there are not enough processor cores, the resulting status is a warning and a specific message. An example:

The number of processor cores in "name-of-the-server" ({1}) is not sufficient. A system that can run {2} file streaming sessions and {3} gang run printing sessions requires at least {4} processor cores.

For the whole cluster, the remaining number of processor cores is checked against the number of defined processing channels. **1 processing channel requires 1 processor core.**



**Note:** The remaining number of processor cores in the cluster is the sum of all remaining cores in each host after subtracting the ones needed for file streaming and gang run printing sessions.

When there are not enough processor cores to run tasks, the resulting status is a warning and a message appears. An example:

The number of processor cores in the cluster available for running tasks ({0}) is not sufficient. There should be at least {1} processor cores available. Please consider reducing the number of file streaming sessions and/or gang run printing sessions or consider upgrading your cluster.

### Memory

This check determines if sufficient memory (RAM) is present for the current Automation Engine setup.

For each Automation Engine server (master and assistants):

- The amount of memory is calculated that is required to run the configured number of file streaming sessions (**Viewer**) and gang run printing sessions. **1 file streaming session requires 1 GB. 1 gang run printing session requires 500 MB.**
- Based on this calculation, if there are is not enough memory, the resulting status is a warning and a specific message is shown. An example:

The amount of memory in "{hostname}" ({1}) is not sufficient. A system that can run {2} file streaming sessions and {3} gang run printing sessions requires at least {4}.

For the whole cluster, the remaining amount of memory is checked against the number of processing channels defined. **1 processing channel requires 2 GB.**



**Note:** The remaining amount of memory in the cluster = the sum of all remaining memory in each host after subtracting the memory needed for file streaming and gang run printing sessions.

If there is not enough memory to run tasks, the resulting status is a warning and a specific message appears. An example:

The amount of memory in the cluster available for running tasks ({0}) is not sufficient. There should be at least {1} available. Please consider reducing the number of file streaming sessions and/or gang run printing sessions or consider upgrading your cluster.

### Tasks

The number of tasks in the tasks database is checked against some predefined thresholds. Also, a check for old tasks is done.

- The thresholds depend on the database version:
  - For an SQL Express edition, the warning threshold is 30.000 and the error threshold is 100.000 .
  - For all other database versions, the warning threshold is 200.000 and the error threshold is none.

- Old tasks are tasks that were launched more than 6 months ago. The check returns a specific message. An example:

The Tasks database contains {0} tasks of which {1} tasks are older than 6 months. Please consider adding cleanup rules for the Tasks database in Configure.

### Scheduled Checks

This page allows to schedule automatic runs of the **Server Checks**. When there are warnings or errors, they send a report via e-mail.

To add a scheduled check, click the **Add Scheduled Check** button.

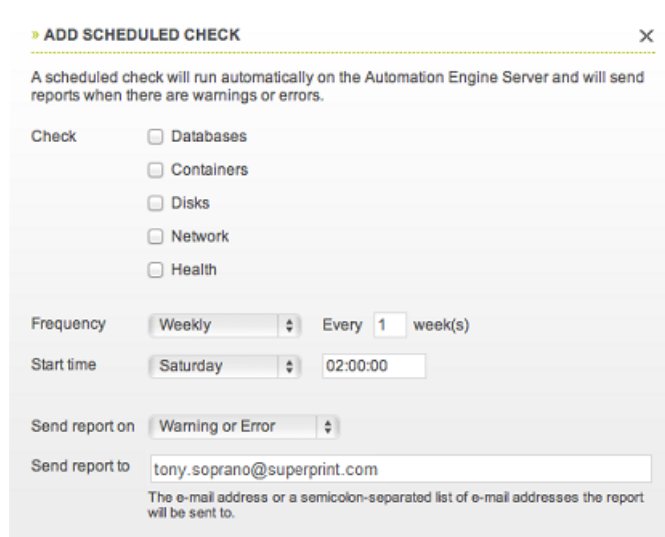

- Select one or more items to **Check**.
- Select the **Frequency** and the **Start time**.
- Specify if you want the report to be sent on **Warning or Error** or on **Error Only**.
- Specify the e-mail address or a semicolon-separated list of e-mail addresses that the report should be sent to.

Click **OK** to add the scheduled check.

Your scheduled check will appear in the list.

Add more if you want to.

This function is available on the AE master server only.

### Settings

CONTAINERS

Warn when used disk space is above (%):

Provide error when used disk space is above (%):

For the check on **Containers**, you can decide the percentage of used disk space that triggers a warning (90% by default) or an error (99% by default).

Enter the new values for the settings you wish to change and close the lock icon to confirm. The new values will be used the next time those checks are done.

## 29.3. The AE Browser Client ADMIN page

---

Go to `http://<AEservername>:9000/#/workspaces`.



**Note:** This page only appears to admin users of an AE server.

This page serves to

- define if you want to have a usage dashboard
- (AE SaaS only) create tokens for external systems that wish to communicate with AE via HTTPS.

### 29.3.1. Usage Dashboard

This page is where you decide if you want to opt in or out of the AE usage dashboard.

On an Automation Engine usage dashboard, you can for example

- see which features you use, and how often,
- learn how many files you process with Automation Engine,
- what the maximum open connections was during the last month.

Technically, the system tracks these categories of events:

- **Task info:** Data related to (sub)tasks that have run on the Automation Engine server.
- **Connection info:** Data related to applications that make connections to the Automation Engine server.
- **System info:** This data is only visible to power users of the dashboard (only visible to Esko).

Click the link on the web page to learn more about what data is being collected.

The system always tracks these events, however,

- when you opt in to get this dashboard, the info will be collected based on the Esko ID that you used for this.
- when you do not opt in to get this dashboard, the info is still collected for Esko but in an anonymous way (i.e. Esko can not see which Esko customer or user this info belongs to).
- when you opt out of this dashboard, the info is still collected for Esko but in an anonymous way.
- when you opt in for a first period, then opt out and later opt in again, then the data from the first period will also be available again in your dashboard.



**Important:** In all cases, Esko never records any information that can be used to identify your client or the designs that you work on (such as text statements, barcodes, separation names or file names). Any personal info like IP addresses or operator names are also not tracked.

## How to Start or Stop the Usage Tracking

### To start usage tracking

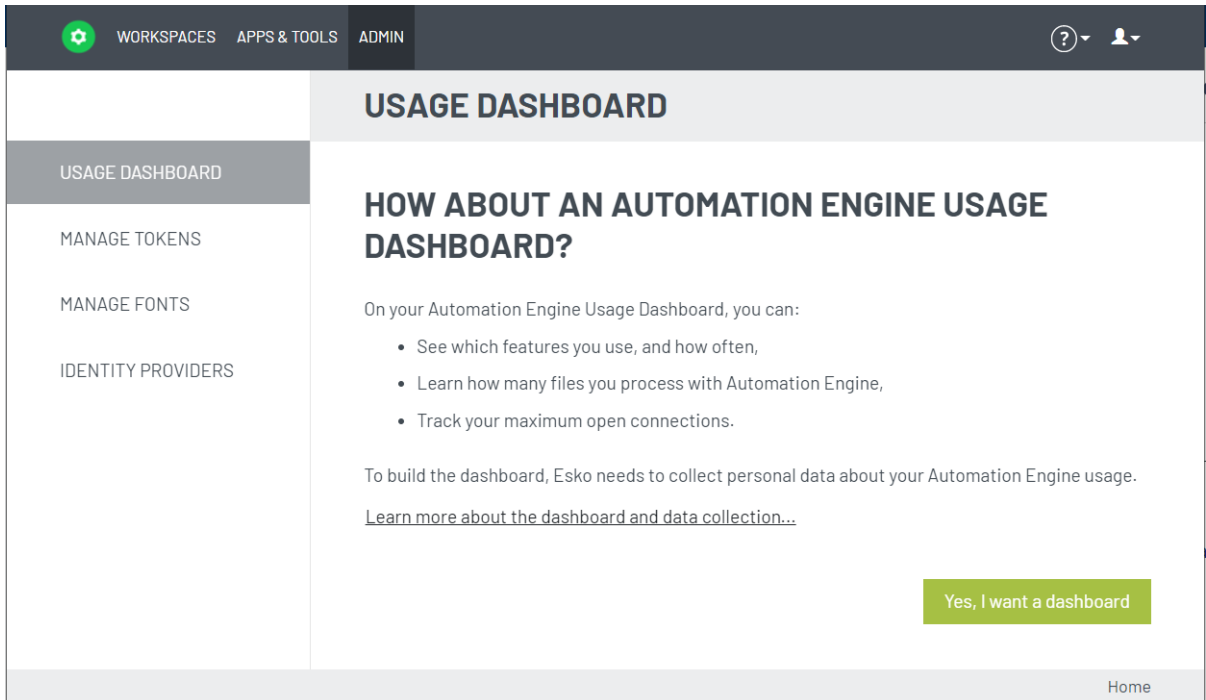

- To opt in, click **Yes, I want a dashboard**.
- Sign in with an **Esko ID** and password.



**Note:** Because a personal Esko ID is more likely to disappear in time, we advise to use a generic Esko ID, one that represents your company or the location of this AE server.

### To stop usage tracking

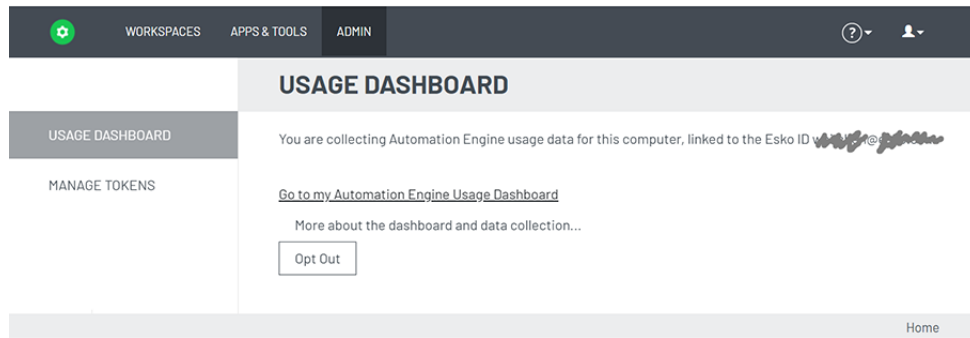

- To stop the tracking, click **Opt Out**.  
This stops the data collection.

## Working with the Usage Dashboard

### Most popular topics to track in Automation Engine

This usage tracking tool is used for several Esko software products. There will be various fields that have no or little use for Automation Engine, as they were designed to track parts of interactive applications like ArtPro+ or Studio.

The main topics to track for Automation Engine typically are:

- **Jobs** worked on
- **Tickets** launched
- Maximum open **connections**.



**Important:** This dashboard is not 'live'. You need to refresh the web page manually to see the very latest data.

### Main dashboard components

- The top bar. Learn more below.
- The default view offers 6 widgets: The 3 on top are counters (they show a number) ; the 3 below show a graph.
- The bottom data table shows a list of events. You select the columns you want to see there. Learn more below.

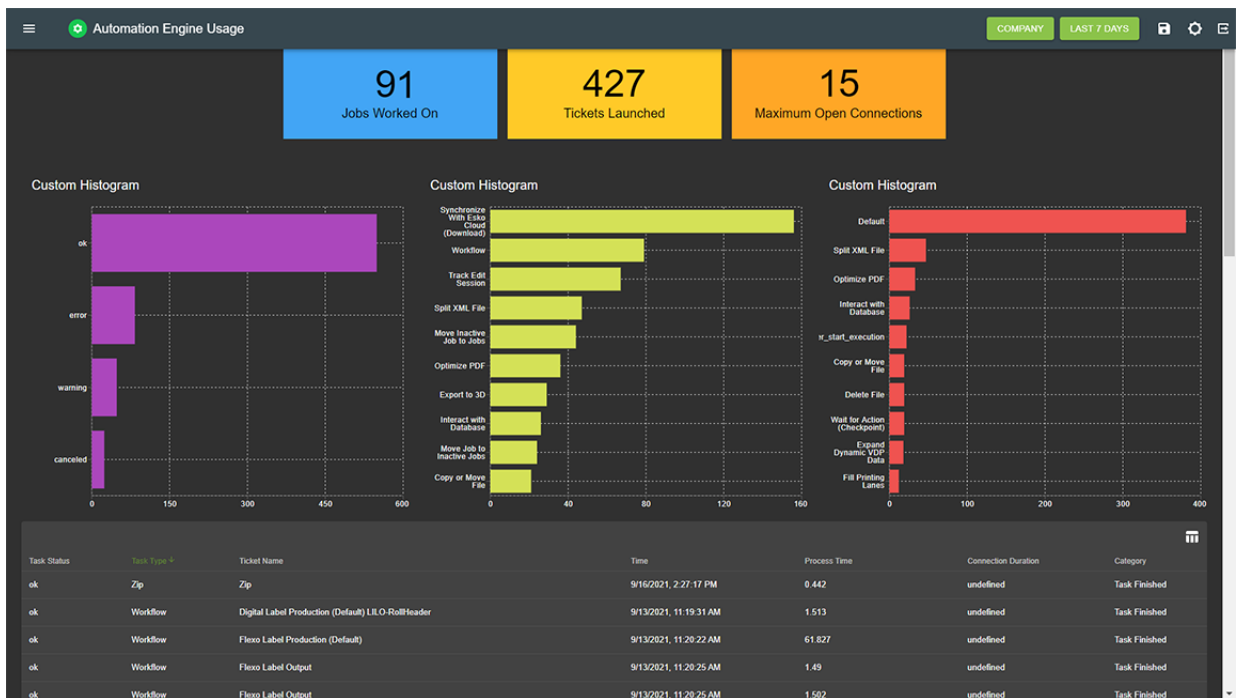

### Top bar tools

- Click to select the dashboard of a different Esko application.
- **Personal / Company:**
  - Select 'Personal' to only see the data that was logged for the current dashboard user (= the current Esko ID)
  - Select 'Company' to see data logged for all Esko ID users that have the same company name as the current dashboard user / Esko ID.
- **Last 30 days:** Click here to define the time range of the dashboard.
- Click to learn that saving the settings on this web page is done via adding a bookmark.
- Click to toggle the brightness mode of the web page.
- Click to sign out of this web page.

### Widgets - Basic Configuration

Hover top right over a widget to make the cogwheel appear: the configuration icon.

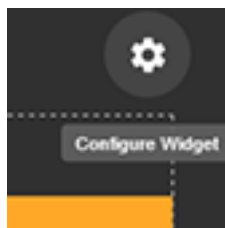



Click  to open the settings of that widget.

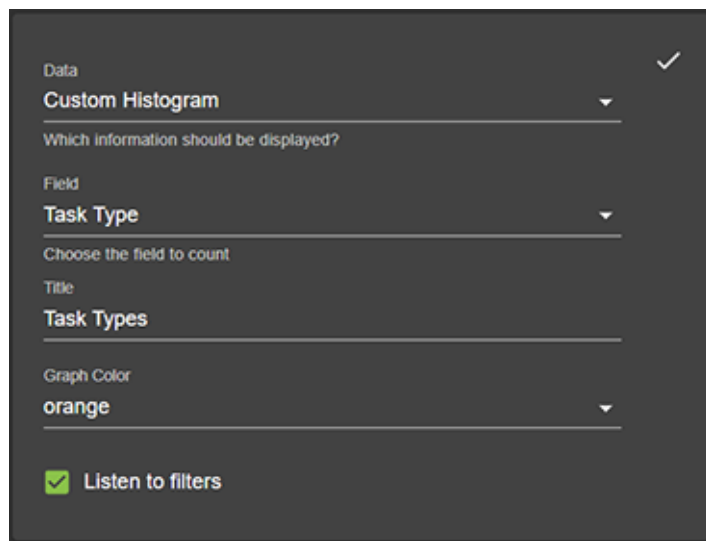

- **Data:** Select the type of data.
  - **Custom histogram:** Shows the number of times each value occurs.
  - **Custom date histogram:** Counts the number of unique values and shows these as a time line.
  - Learn more in [Examples](#) on page 2047.
- **Field:** Select the field of data. Learn more below in [Examples](#) on page 2047.
- **Title:** Type a title for this widget.
- **Graph Color:** Select a color for this widget.
- **Listen to filters:** Define if this widget should listen to any filters that were set on this page. Learn more below.

Click  (top right) to confirm any changes and close this dialog.



**Note:** When, after confirming changes to the widget, you see no differences or the widget shows empty, just refresh the browser page to re-establish the connection.

### Widgets - Zooming and Filtering

An example:

- Hover over a field to see so more details.

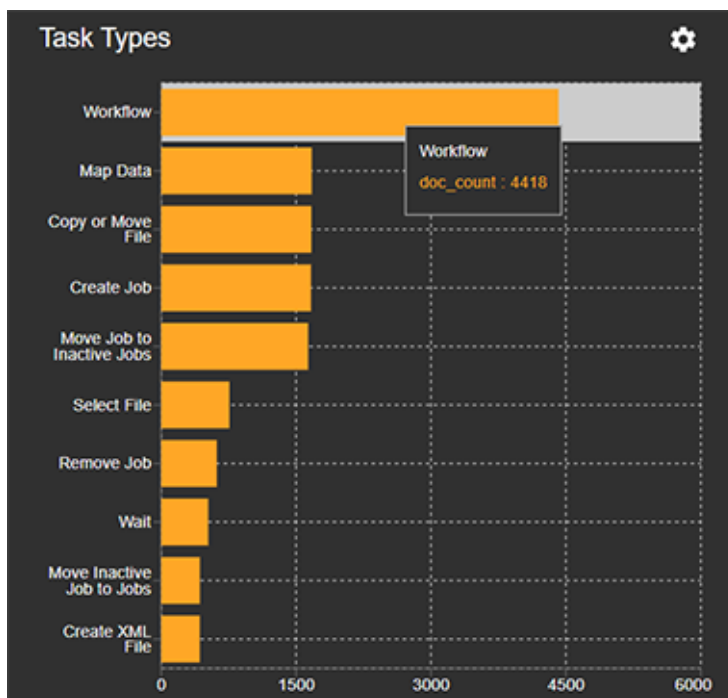

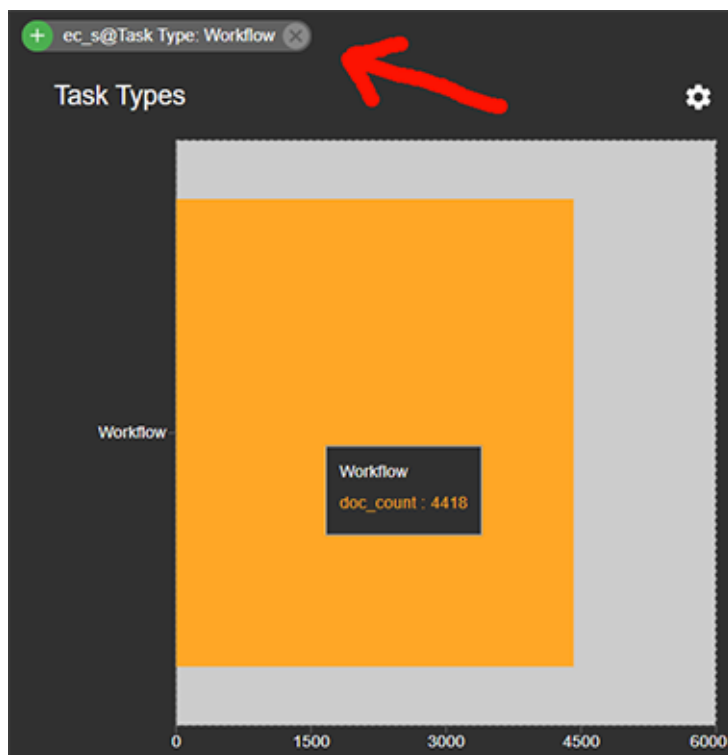

- Click on the field to zoom in to that field. This also automatically makes a filter for that field appear (by default in the middle of the page, starting on the left).



A filter initially starts with this icon .

You can add several filters, and they can come from different widgets.

- On a filter, you can either:

- Click the  icon to remove that filter and so make the widget zoom out again.
- Click on the  icon to execute that filter which will change it to an  icon. This means that that field is now filtered out of the view of any widget that has the setting 'Listen to filters' switched on ( Listen to filters).

See how in our example the field 'Workflow' is now filtered out of our graph with task types:

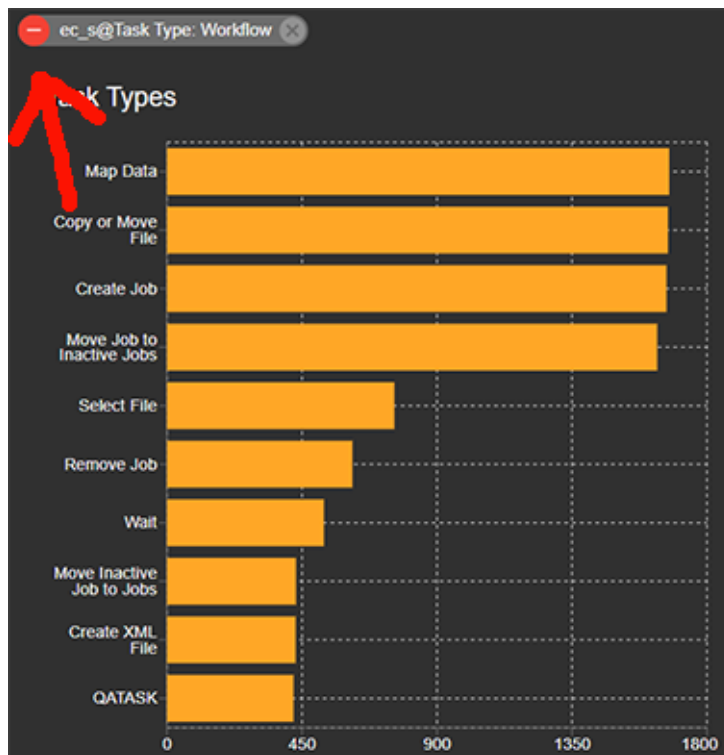

### Table

The bottom of the page shows a table list of events.

Time	Category	Event	Task Status	Task Level	Task Type	Ticket Name
10/13/2021, 5:25:31 AM	Task Finished	Main Task	warning	tsk	Export to Normalized File (DeskPack Only)	GNG_nPDF_out
10/13/2021, 5:26:09 AM	Task Finished	Main Task	warning	tsk	Export to Normalized File (DeskPack Only)	GNG_nPDF_out
10/13/2021, 9:57:32 AM	Task Finished	Main Task	warning	tsk	DeskPack Workflow	PowerLayout Client
10/15/2021, 3:59:19 AM	Task Finished	Main Task	warning	tsk	Export to Normalized File (DeskPack Only)	GNG_nPDF_out
10/20/2021, 4:02:32 AM	Task Finished	Main Task	warning	tsk	DeskPack Workflow	PowerTrapper

- Click  to select the wanted columns.



**Important:** The list also adapts to any active filters.

- Sort the table by clicking on a column header.
- Hover to the right side of any value to see a + and - sign to also set a filter for this type of value.
- To ensure that this info is hidden for Esko, some fields were made anonymous by showing them as a hash-key. For example the field **Document ID**, which means that Esko can not see the actual names of your tasks' input files.

Description of data table fields (per name of column):

- **User:** This is the internal user of this tracking software (based on the Esko ID and the current opt-in session). This is not the name of a user of Automation Engine. This field is shown as a unique hash-key and so made anonymous.
- **Time:** UTC time in milliseconds since the Unix epoch (1/1/1970).
- **Document ID:** Unique hash-key string based on the input files of the ticket.
- **Category:**
  - for task events: 'Task Finished', ...
  - for connection events: 'Connection'
  - for system events: 'System'
- **Events:**
  - for connections: **Connection Counter, Session Started, Session Finished, Session Expired.**
  - **Main Task:** The task type that the user (or a tool) started. This is either the type of the task that was launched, or it could be the type 'workflow'.
  - **Sub Task:** All other task types.
- **Application:** Automation Engine.
- **Company Code:** Company code of the used Esko ID.
- **is Esko:** Boolean field (true or false) indicating if the data was tracking inside the Esko network.
- **Connection Duration:** In milliseconds.
- **Process Time:** Time that was needed to process the ticket (in seconds).
- **Connection Counter:** The new number of active connections.
- **Connection Application:** The (human readable) name of the application making the connection. For example **Automation Engine Browser Client** or **ArtPro+ 22.03.123**. In case the application does not provide a proper name, an application ID is used.
- **Connection ID:** Unique ID of the connection.
- **Connection IP:** Hash-key of the IP address of the computer making the connection.
- **Connection User:** Hash-key of the user name making the connection.
- **Job ID:** (Optional) hashed string based on the Job ID of the ticket.
- **Task Level:** Possible values:
  - tsk (plain task)
  - sub (sub task)
  - der (derived task)
  - wfs
  - wfe
- **Task Status:** End status of the task (possible values: 'error', 'warning', 'ok', 'canceled).
- **Task Type:** Type of AE task executed by this ticket.
- **Task Type (internal):** Internal (non localized) name of the task type.
- **Ticket Name:** Name of the AE task ticket.
- **Workflow ID:** ID of the workflow that this ticket is part of.

- **Source:**

**Examples**

These are some classic ways to track the usage of Automation Engine. Their resulting URL can be bookmarked for future use.

**Configuring Graphs**

- **Number of times a task type is launched**
  - Make a **Custom Histogram** based on **Task Type**.

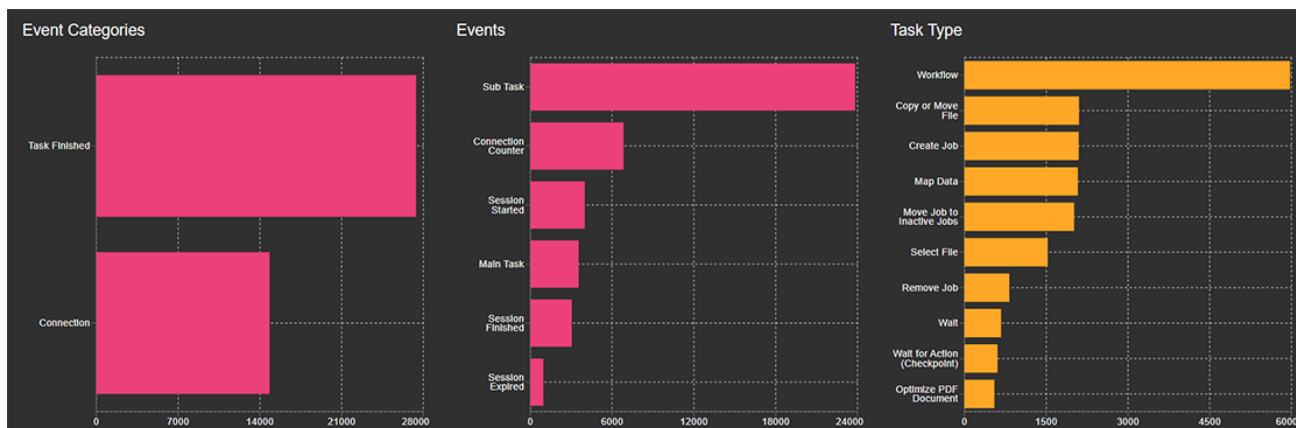
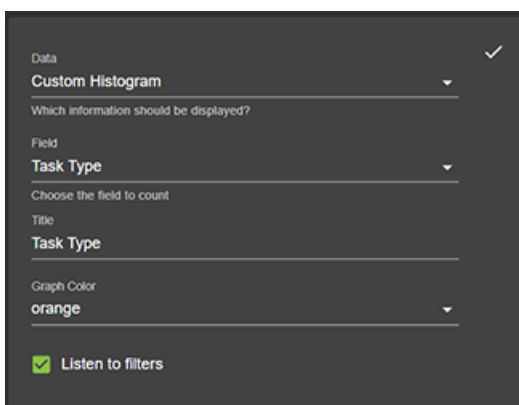

- Some examples to filter further:
  - In the graph 'Events', filter (click) on **Main Task** to make the graph 'Task Type' only show the task types that were actually launched by a user (or tool), which means it will no longer show sub tasks of a workflow.
  - In the below data table, check or filter on **Task Status** to see which ones ended as **ok**, **warning** or **error**.

- **Number of times a ticket is launched**
  - Make a **Custom Histogram** based on **Ticket Name**.

Data  ✓

Custom Histogram

Which information should be displayed?

Field

Ticket Name

Choose the field to count

Title

Ticket name

Graph Color

orange

Listen to filters

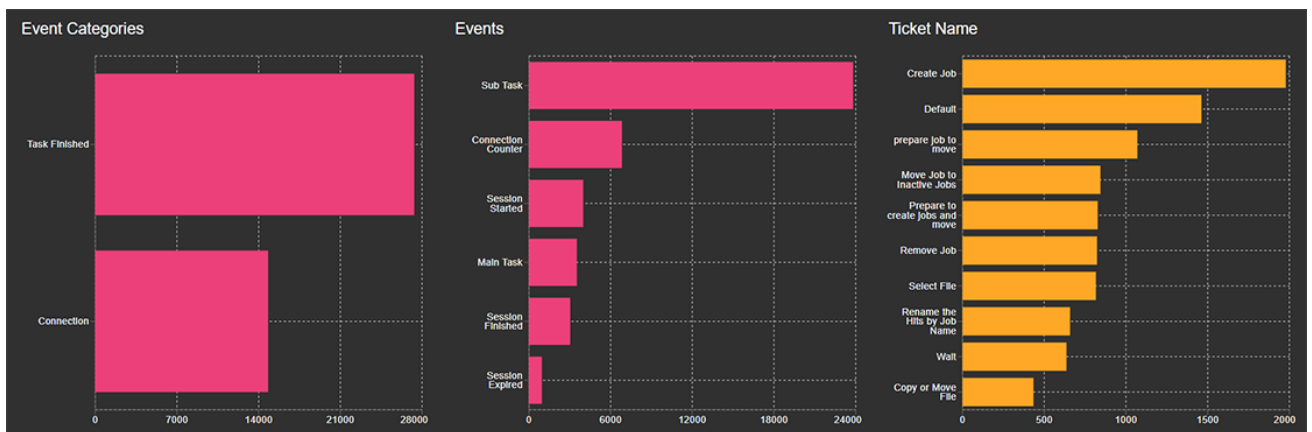

- Same examples as above to filter further:
  - Filter on **Main Task**.
  - In the table, check or filter on **Task Status**.
- **Time line of number of workflows that have run on the system**
- Make a **Custom Date Histogram** based on **Workflow ID**.

Data  ✓

Custom Date Histogram

Which information should be displayed?

Field

Workflow ID

Choose the field to count

Interval

day

Title

Workflows started

Graph Color

orange

Listen to filters

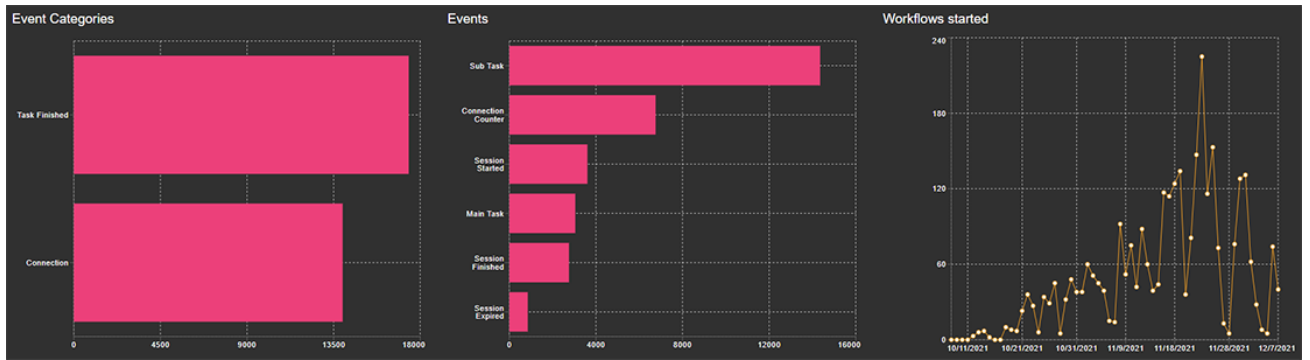

- **Time line of number of (main / sub) tasks that have run on the system**
  - Make a **Custom Date Histogram** based on **Time**.
  - Then, in the graph **Event Categories**, filter on **Task Finished**.

The screenshot shows a configuration panel for a 'Custom Date Histogram'. It includes a 'Data' dropdown set to 'Custom Date Histogram', a 'Field' dropdown set to 'Time', an 'Interval' dropdown set to 'day', and a 'Title' field containing 'Number of tasks finished'. The 'Graph Color' dropdown is set to 'orange'. A 'Listen to filters' checkbox is checked.

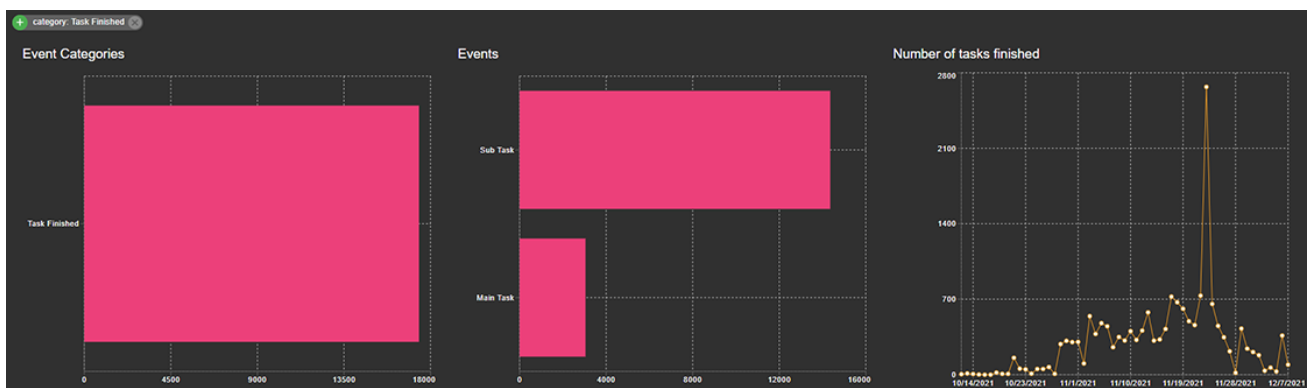

You could filter further on main / sub tasks or even build a graph for a specific task type or ticket name.

### Logging Connection Sessions

- **Total number of connections per application**
  - Make a **Custom Histogram** based on the field **Connection Application**.

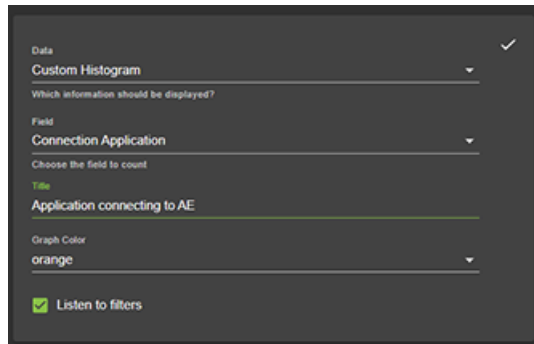

- Then, in the graph **Event Categories**, filter on **Connection**. And in the graph **Events**, filter on **Session Started**.

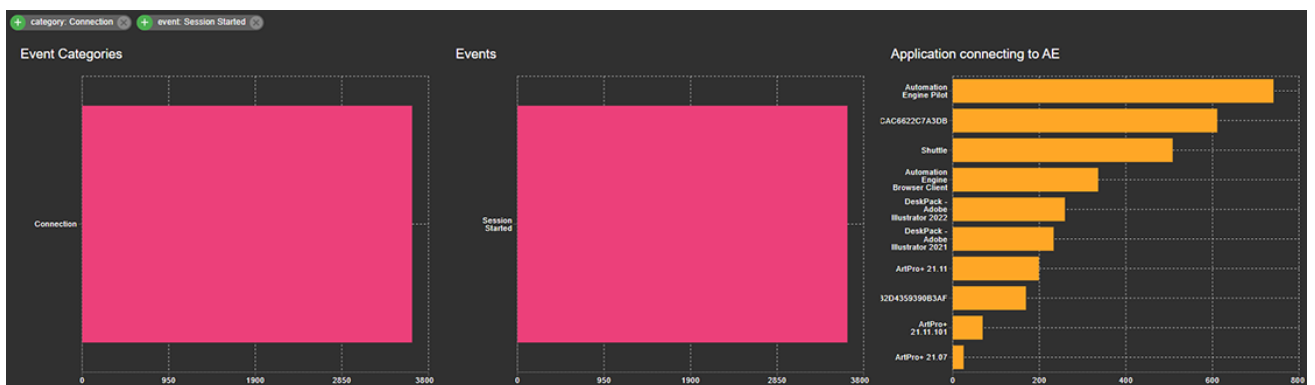

- **Time line of number of connections created:**
  - Make a **Custom Date Histogram** based on **Connection ID**.

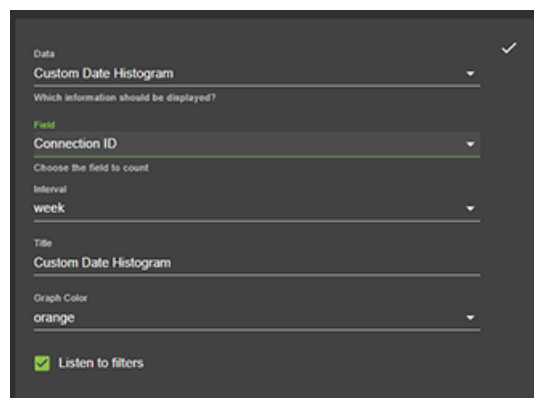

This shows a graph with the number of new connections made per day



**Note:** This gives no indication of the system's peak load ; it does not show the total number of connections open at some point in time.

- Then, in the graph **Event Categories**, filter on **Connection**. And in the graph **Events**, filter on **Session Started**.



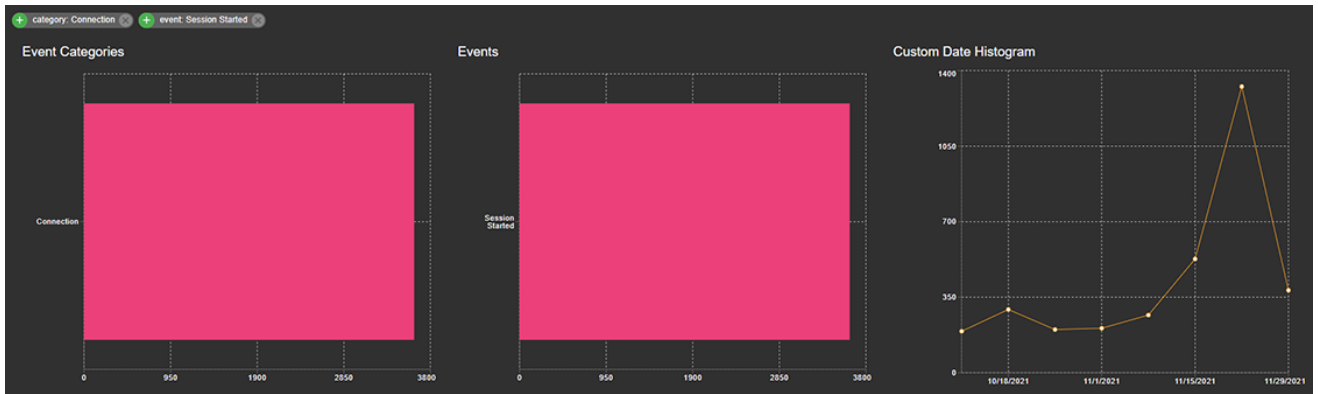

- **Connection Load**

- This is a pre-defined graph specifically for Automation Engine.

As **Data**, select **Maximum Open Connections**, and keep the default other field **Connection Counter**.

The configuration form includes the following settings:
 

- Data:** Maximum Open Connections
- Field:** Connection Counter
- Interval:** day
- Title:** Maximum Open Connections
- Graph Color:** red
- Listen to filters

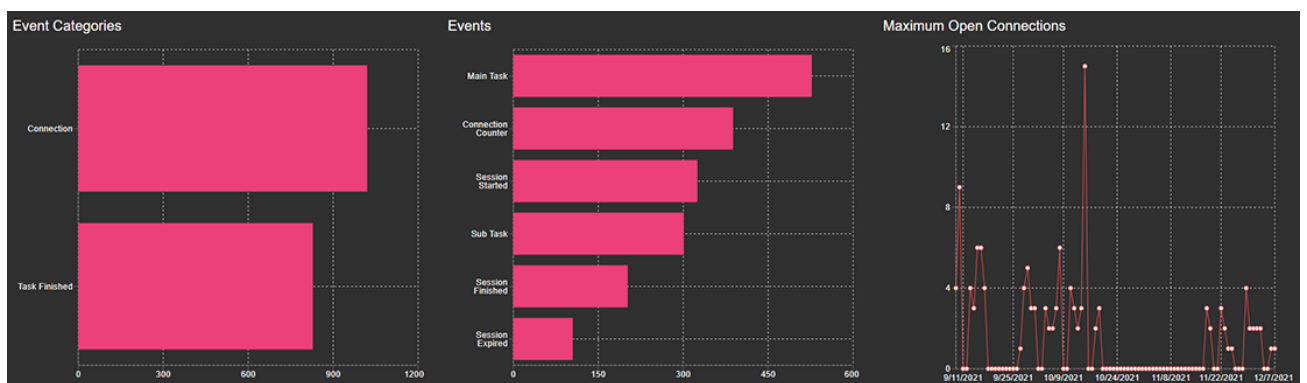

- **Number of jobs processed**

- Make a **Custom Date Histogram** based on **Job ID**. Select an **Interval** as wished.

Data

Custom Date Histogram

Which information should be displayed?

Field  
Job ID

Choose the field to count

Interval  
day

Title  
Jobs Processed (day)

Graph Color  
red

Listen to filters

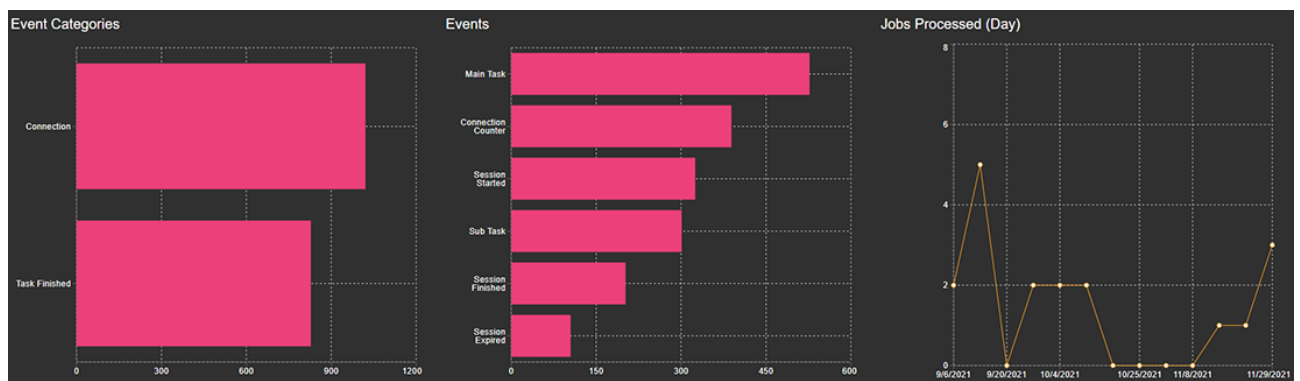

- **Time line of number of documents processed**
  - Make a **Custom Date Histogram** based on **Document ID**. Select an **Interval** as wished.

Data

Custom Date Histogram

Which information should be displayed?

Field  
DocumentID

Choose the field to count

Interval  
week

Title  
Documents processed

Graph Color  
orange

Listen to filters

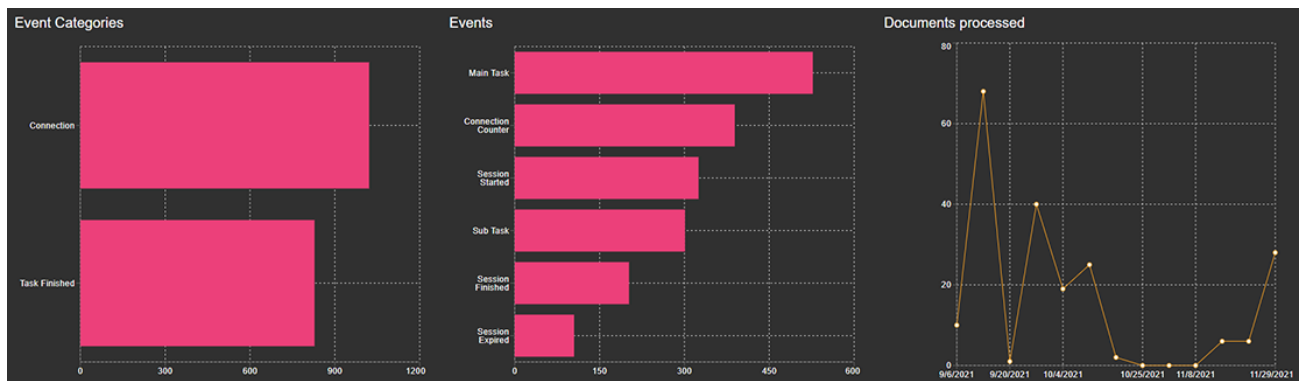

- You can further filter on 'Main Task' or 'Sub Task'.



**Note:** The 'Document ID' is a hash-key based on the input file names. If a ticket was launched with 3 files, the hash-key is based on all 3 files. An identical ID therefore means it is the exact same set of input files.

### 29.3.2. Manage Tokens (SaaS only)

An external system that wants to communicate with Automation Engine via HTTPS requires a token.



**Tip:** Using tokens is typically an alternative to using a user name and password.

An administrator can use this page to generate such tokens.

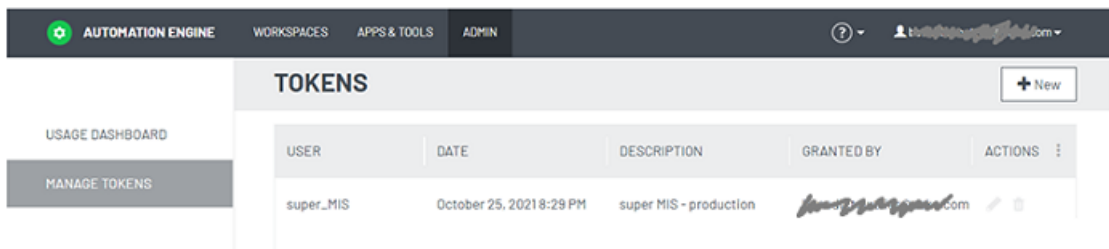

**Note:** The actual token itself is never shown here.



**Note:** A local [Agent](#) also uses a token. These are linked to an Automation Engine user named "Agent User: <Name-Of-Agent>".



**Note:** Technically, these tokens are 'process tokens'.

### Settings

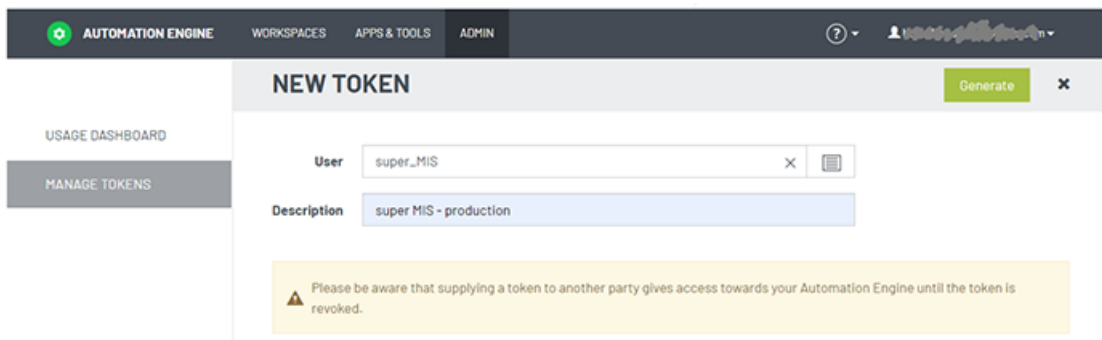

- Click **+ New** to open the New Token page.
- **User:** The AE user that wants to use this token to make use of the AE SaaS server. The token will be specific for this user.



**Note:** A user can only be linked with (have) 1 token. Making a new one for this user will revoke the previous one. When the assigned AE user no longer exists, the token will be revoked and disappear from this list.

- **Description:** Add a description about where this token will be used.



**Note:** Click **Edit** to (only) change the description of a token.

- **Revoke:** You will be asked to confirm.

Click **Generate** to generate the token. When a new token is generated, the token is copied to the clipboard (as explained in a pop-up message).

### 29.3.3. Manage Fonts

#### Concept

This page allows an administrator to upload fonts to the central fonts folder on your Automation Engine server (both in an on-premises setup and a SaaS setup).



**Note:** Both new (NDL) and classic (BRIX) tasks use this central fonts folder.

These fonts are typically those that you use in mark sets or report templates.



**Note:** Non-recurring fonts (typically design specific fonts) are typically managed by the tasks used in VDP and automated artwork generation, where you indicate their local location in the task ticket.

#### How to

- Font files with these extensions can be uploaded: .afm, .cmap, .fnt, .map, .pfa, .pfb, .pfm, .otf, .otc, .ttf, .ttc .
- Drop font files on the dedicated drop zone (or click the drop zone and select them). When a valid font file is dropped, you are first asked to confirm that you are not violating any copyright law.
- Fonts are then uploaded to the shared folder BG\_DATA\_FONTS\_V040 on the Automation Engine server.



**Note:** This folder is part of the resources that is included in an AE [backup](#).

### Fonts list

The  **FONTS**  page shows the central fonts. Use the filter and columns to find or sort them.

The only available action is to delete one or multiple fonts. You will be asked to confirm.

Click to manually refresh the page.

## 29.3.4. Load History

### Concept

This page shows the evolution of the load on your AE server software over a selected period of time.

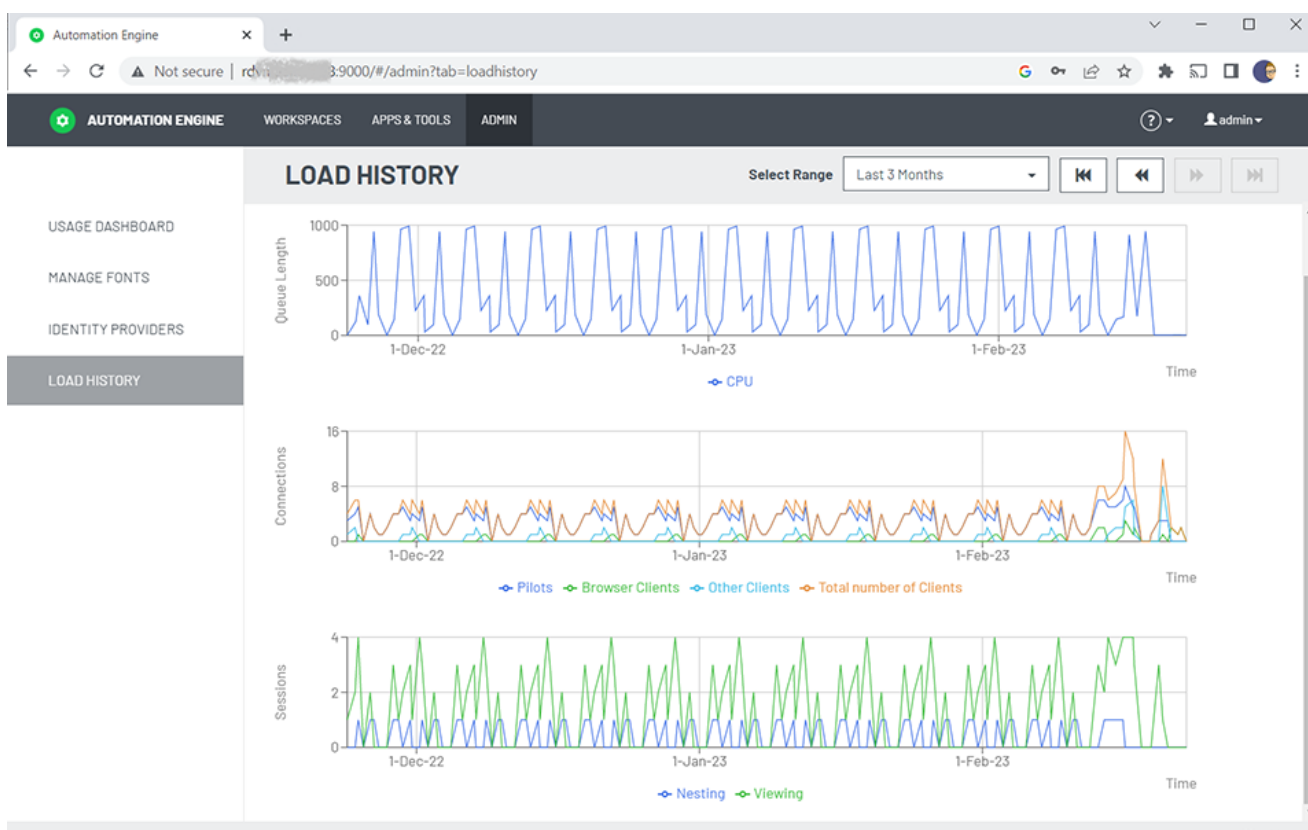

### Time Range Selector

Click **Select Range** to select a time period.

Use the buttons to jump to the first, previous, next or last period as the one selected.



**Note:** Your options in the range selector are restricted to the available data samples. For example: When the server only has such data available for the last month, your choice in the range selector will be limited to **Last Week**.

Some FAQs:

- **Does it show LIVE data?** No. Also, the most recent data is not shown. The maximum of this period of not shown data is the last 24 hours.
- **How long does it keep data?** The AE server only collects such data up to a maximum size on disk, i.e. old sample data will automatically be removed.
- **Can I export this data?** No.

### Types of Data

This page shows 3 types of data:

- **Queue Length:** This graph shows the amount of entries in the CPU queue. These are tasks that are being executed or are waiting to be executed (pending or holding). Learn more about the CPU queue in [Queue Monitor](#) on page 144.

Things you can learn here:

- A queue length that goes beyond the maximum processing channels means tasks are waiting (queueing) to be processed.
- Whether waiting tasks is bad or not depends on the expectations.
- Peaks are absolutely normal. What matters is how peaks are resolved ; upward trends might point to problems.

Two potential causes and how to fix them:

- Not enough **resources:** Available processing channels are not used because there is insufficient RAM / CPU.

This can be fixed by adding RAM / CPU to the computer and/or by adding an Assistant server (learn about Assistants in [Server Setup](#) on page 2011).

- Not enough **processing channels:**

This can be fixed by adding more licenses for processing channels. Learn more in [Processing Capabilities](#) on page 2015.

- **Connections:** This graph shows **Pilots, Browser Clients, Other Clients** (for example editors, Curve Pilots) and the **Total number of Clients** (the combo of those 3 types).

Here you can learn whether your server is hitting the licensed limit of client connections.

Tip: You can see the amount of live connections in the Pilot's [Users view](#).

- **Sessions:** This graph shows two types of server activity that are not tasks but can still add a significant load on the server software.
  - **Nesting** sessions. Learn more in [The Gang Run Printing View](#) on page 984.
  - **Viewing** sessions. Learn more in [Automation Engine Viewer](#) on page 1077.

Here you can learn whether you're hitting the configured limits for these viewer / nesting sessions. Learn more about these limits in [Processing Capabilities](#) on page 2015.

Hover your mouse over the graph to see the data values of the curves at that point in time.

### 29.3.5. View Sessions

#### Concept

This page shows the activity of users using the Automation Engine Viewer. Any updates are done live.

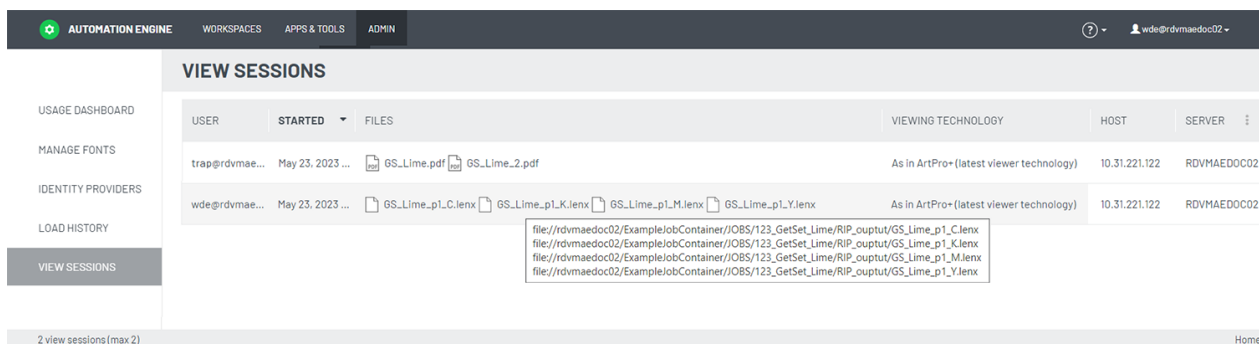

USER	STARTED	FILES	VIEWING TECHNOLOGY	HOST	SERVER
trap@rdvmae...	May 23, 2023 ...	GS_Lime.pdf  GS_Lime_2.pdf	As in ArtPro+ (latest viewer technology)	10.31.221.122	RDVMAEDOC02
wde@rdvmae...	May 23, 2023 ...	GS_Lime_p1.C.lenx  GS_Lime_p1.K.lenx  GS_Lime_p1.M.lenx  GS_Lime_p1.Y.lenx	As in ArtPro+ (latest viewer technology)	10.31.221.122	RDVMAEDOC02

file:///rdvmaedoc02/ExampleJobContainer/OBS/123\_GetSet\_Lime/RIP\_ouptut/GS\_Lime\_p1\_C.lenx  
file:///rdvmaedoc02/ExampleJobContainer/OBS/123\_GetSet\_Lime/RIP\_ouptut/GS\_Lime\_p1\_K.lenx  
file:///rdvmaedoc02/ExampleJobContainer/OBS/123\_GetSet\_Lime/RIP\_ouptut/GS\_Lime\_p1\_M.lenx  
file:///rdvmaedoc02/ExampleJobContainer/OBS/123\_GetSet\_Lime/RIP\_ouptut/GS\_Lime\_p1\_Y.lenx

This page helps to

- see who is viewing which file (and on which computer)
- understand the current load of viewing sessions. The status bar at the bottom of the page shows the total number of active view sessions and the maximum view sessions *allowed on this system*. Learn more in [Load History](#) on page 2055.
- understand why ArtPro+ tells you a file is locked. The error message 'incorrect permissions' appears in ArtPro+ when trying to save a file that is already open in a Viewer.



**Tip:** In the [Pilot - Users view](#), you can ask to **Show All Connections** which will list all types of connections that that or all users currently have to the server.

#### Columns

- **User:** The AE user account that started the view session (only showing a value when using "As in ArtPro+ (latest view technology)").
- **Started:** The time this view session was started.
- **Files:** Name(s) of the opened file(s). A tool tip shows the full URL. Depending on which view technology is used, comparing files can take multiple sessions or only 1 session. The latest view technology is capable of opening multiple files in 1 session.
- **Server:** The AE server (Master or Assistant) hosting the view session.
- **Viewing technology:** The technology this session uses (as defined in the [Configure panel](#)).
- **Host:** The remote host (IP address) from where the user started the view session (only showing a value when using "As in ArtPro+ (latest view technology)").

### 29.3.6. Agents (SaaS only)

This page offers an overview of all known Agents, their name, status and version.

NAME	STATUS	VERSION	ACTIONS
agento...	connected	23.07.147	[trash icon]
AgentO...	offline		[trash icon]
ESKO...	connected	⚠ 23.11.63	[trash icon]
ESKW...	connected	⚠ unknown	[trash icon]

It allows an administrator

- to see which Agent installations still might need to be updated.



**Note:** The version will be 'unknown' for Agent versions before v23.07

- to see the status of an Agent without having to sign in to the AE server computer in the data center. The status **offline** can also occur when there is a problem with the token used for that Agent or when the required service has been stopped.
- to see Agents that are no longer connected to server.
- to delete an Agent, which will also remove the corresponding user and token. A confirmation is asked.



**Note:** Deleting an Agent stops the service (when it was a connected Agent) and removes the corresponding user and token. This means that access to the server via this user/token is immediately denied. The deleted Agent will disappear from this list.



**Note:** An Agent (service) can be "gone" here, but a corresponding Agent user or an Agent token (both having the same name as the Agent) could still exist. The (Agent) token is listed in the page [Manage Tokens](#) and the Agent user is listed in the [Users View](#) in the Pilot. The Delete action on this page can be used to clean up such users or tokens.

There is no live update of this list. A manual page refresh is necessary if an Agent gets connected or is removed elsewhere.

### 29.3.7. System History

This page is available both in the ['Server Config' web pages](#) and in the [browser client 'Admin' pages](#).



### Concept

This page shows the changes that were done to (part of) the configuration of your AE server. This info can serve regulatory requirements or can be useful to troubleshoot an issue.



**Note:** IDP configuration changes triggered by a backup-restore and IDP changes done outside the UI (example: by editing the XML) are not tracked and will not show up here.



**Note:** AE SaaS customers will not see the details for configuration changes on 'Esko managed' configuration items (for example: Esko changed Identity Providers on date/time).



**Note:** IDP Client secrets and passwords are never exposed here.

These configuration changes are logged in the database after a minute. There is no live update. Click  to refresh this page manually.

There is also a search field (searches on columns 'User' or 'Date').

In the [Configure tool](#), you can define how long this type of data should be kept in the database.

### Columns

- **Date:** The date and time when the change was made.
- **User:** The user who made the change. This will be `(local administrator)` when changes were done using the [Server Config pages](#).
- **Category:** `Identity providers`. In this version of AE, this page shows changes to configuration in the page [Identity Providers](#).
- **Details:** A detailed description of what has changed.
- **Type:** `Config change`: In this version of AE, the only type is the one listing configuration changes.

## 30. Troubleshooting

---

Automation Engine administrators can easily run diagnostic tests on the Automation Engine server and on the Pilot. These tools help to understand and fix the problems without help from Esko support.

### 30.1. Alerts

---

#### Concept

Alerts is an (old) tool to inform Pilot users about important events related to Automation Engine's working or configuration.

Many of these events are also managed with more recent tools, like the ['Server Checks'](#) or the ['Connection Doctor'](#).

Typical for alerts is that they pop up in the Pilot, in a separate dialog.

#### Types and examples

- A red alert reports a system problem or urgent important information. For example: Containers that can't be accessed, database problems, not enough disk space, upcoming shutdown of the server, communication related errors (Access Points), etc.
- An orange alert advises you to make some change. For example: Change how a workflow is constructed because it generated an excessive amount of [tokens](#) (which slows down the server).

#### Managing Alerts

- Cleanup: You can manually (multi-)select items and press 'delete'. There is also a regular automatic cleanup that will keep this list to a maximum of 1.000 alerts.
- Some alerts can be switched off. This is done per user. Learn more about 'Edit Red Alerts' in [Users View](#) on page 153

### 30.2. Troubleshooting the Server

---

In the **Automation Engine Server Admin** web page, the section **Server Checks** helps an Automation Engine administrator to diagnose and fix any problems.

You can open the Server Admin web page by entering `http://<name of your server>` or `http://<name of your server>:9999` in the address field of your browser.



**Note:** You will be asked to sign in using an administrator account or use an account that is a member of the **BGADMIN** user group on the Automation Engine server.

These server checks are documented in the chapter [Automation Engine Server Management](#). They are part of [The AE Server ADMIN web page](#) on page 2009, more specifically in [Server Checks](#) on page 2032.

Another type of check is offered on the page [Load History](#). It offers a historical view on the load on the Automation Engine server software.

### 30.3. Troubleshooting the Pilot

The **Connection Doctor** checks if the Pilot's connection to the Automation Engine server works properly. This tool helps you to fix a problem without the need to contact Esko support.

#### Consulting the Connection Doctor

In the Pilot, choose **Tools > Connection Doctor**.

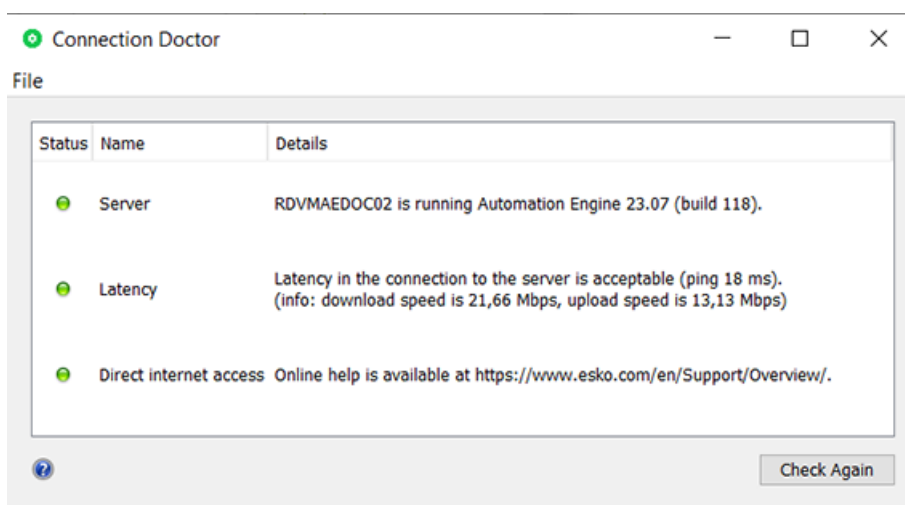

**Note:** When you have troubling signing in to the Pilot (or Shuttle), the error message will offer a button to start up this tool:

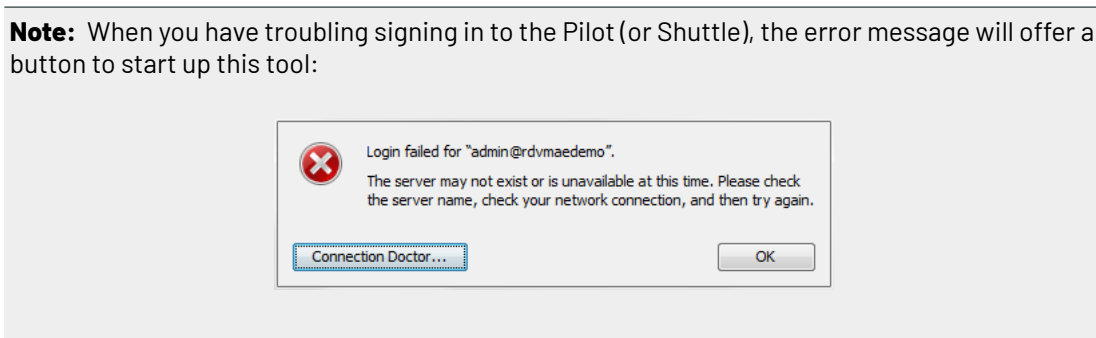

This tool checks:

- Access to the Automation Engine server software
- Latency in the network between client and server (green/OK status till 50 ms ; red/problem status when 100ms or higher)
- Direct access to the internet (of this client computer).

#### Status Details

Detailed messages explain the result of the check:

Table: Server

Message	Clarification
<p><b>The Automation Engine server is down for maintenance. Please try again later or contact your administrator.</b></p>	<p>The maintenance status includes: server updates, server upgrades or the installation of hot fixes.</p>
<p><b>The Automation Engine server is restarting. Please try again in a moment.</b></p>	<p>This can take a few seconds to a few minutes.</p>
<p><b>The server you're connecting to is an assistant server. Please connect to the master server &lt;host_name of the master&gt;.</b></p>	<p>In setups where Automation Engine runs on multiple servers, one server is designated as master. The other servers take up the role of assistants. The master server is the server you need to log in to.</p>
<p><b>The server is currently set to idle. Please try again later or contact your administrator.</b></p>	<p>When a server has no or expired licenses and a server restart is done, the server starts up in <b>idle</b> mode ; it then does not accept connections.</p>
<p><b>There was a problem connecting to &lt;host_name&gt;. Please check that the host name is correct and &lt;host_name&gt; is on.</b></p>	<p>This computer is unable to connect to the host. Please check that the host name is filled in correctly and that the computer is switched on. Contact your IT department for more assistance.</p>
<p><b>There was a problem connecting to &lt;host_name&gt;. Please check that the server is running.</b></p>	<p>This client computer is unable to connect to the Automation Engine server. The most common reason for this is that the server software is not running.</p> <p>If the server software is running, check if your computer is correctly connected to the network. Contact your IT department for more assistance.</p>
<p><b>There was a problem connecting to &lt;host_name&gt;. Please check that the server is running, and verify with your IT administrator if the "&lt;host_name&gt;'s" host file is correct.</b></p>	<p>This computer is unable to connect to the Automation Engine server. The most common reason for this is that the server software is not running.</p> <p>If the server software is running, verify if the <b>hosts file</b> of your operating system is correct. The hosts configuration of this computer contains explicit references to the Automation Engine server's host name and its IP addresses. A configuration error could be the cause of this connection problem.</p> <p>Contact your IT department for more assistance.</p>
<p><b>There was a problem connecting to &lt;host_name&gt;. Please check that your computer is connected to the network.</b></p>	<p>This computer is unable to access the network. You can try and diagnose the problem by using one of the following methods:</p> <ul style="list-style-type: none"> <li>On Mac, go to: <b>Applications &gt; System Preferences &gt; Network &gt; Assist me...</b> to test your connection .</li> </ul>

Message	Clarification
	<ul style="list-style-type: none"> <li>On Windows, go to: <b>Start &gt; Control Panel &gt; Network and Internet &gt; Network and Sharing Center &gt; Troubleshoot Problems &gt; Network Adapter</b> to test your connection.</li> </ul>

Table: Latency

Message	Clarification
<b>Latency in connection to the server is acceptable.</b>	The response time between this computer and the server (the 'ping') is less than 20 milliseconds, which is considered good (green status).
<b>Latency in connection to the server can be problematic.</b>	The response time between this computer and the server is between 20 milliseconds and 100 milliseconds (orange status). This is OK for normal operations.
<b>Latency in connection to the server is likely unacceptable.</b>	The response time between this computer and the server is more than 100 milliseconds (red status). This is considered too slow for normal operation. Consult with your IT department what can be done to improve the speed.

Table: Direct internet access

Message	Clarification
<b>Esko online help is available at <a href="http://help.esko.com/">http://help.esko.com/</a>.</b>	This computer can access the internet.
<b>Pilot was unable to connect to the Internet. Please check the Internet proxy preferences of your operating system if you have experience problems accessing Esko online help.</b>	This computer was unable to connect to the internet (it failed to, as a sample test, access Esko's help pages). Check the internet proxy preferences of your operating system. Contact your IT department for more assistance.



**Note:** When Esko's online help pages are unreachable, a warning text is shown. This does not necessarily mean that the online help is unavailable. Your internet browser, which is used to display the help pages, may be configured with an internet proxy that enables you to access the online help even if the Pilot is unable to connect to it. Please contact your IT administrator for more information.

## 30.4. Troubleshooting the Software

The **Diagnostics** tool allows you to monitor the status and activity of the Automation Engine software in deep technical detail. This tool is typically used by Esko support staff. In case they want you to use it, they will instruct you how to use it.

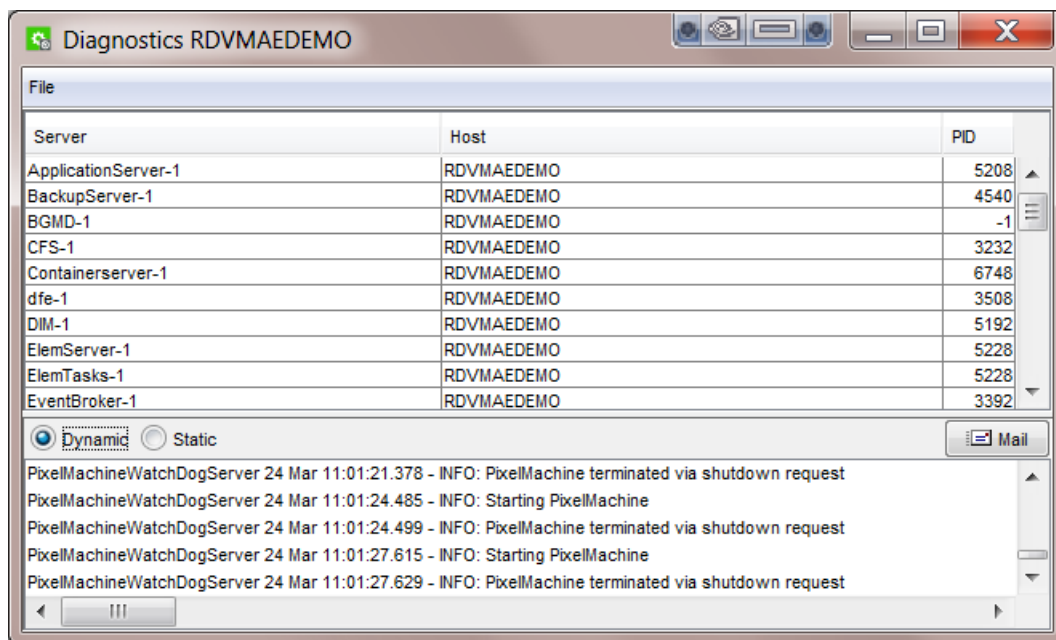

This tool is installed automatically when installing the 'Desktop Client Applications' (Pilot or Shuttle) as described in [How to Install Pilot or Shuttle](#) on page 1988.

## 31. Copyright Notice

---

© Copyright 2023 Esko Software BV, Gent, Belgium

All rights reserved. This material, information and instructions for use contained herein are the property of Esko Software BV. The material, information and instructions are provided on an AS IS basis without warranty of any kind. There are no warranties granted or extended by this document. Furthermore Esko Software BV does not warrant, guarantee or make any representations regarding the use, or the results of the use of the software or the information contained herein. Esko Software BV shall not be liable for any direct, indirect, consequential or incidental damages arising out of the use or inability to use the software or the information contained herein.

The information contained herein is subject to change without notice. Revisions may be issued from time to time to advise of such changes and/or additions.

No part of this document may be reproduced, stored in a data base or retrieval system, or published, in any form or in any way, electronically, mechanically, by print, photoprint, microfilm or any other means without prior written permission from Esko Software BV.

This document supersedes all previous dated versions.

PANTONE® Colors displayed in the software application or in the user documentation may not match PANTONE-identified standards. Consult current PANTONE Color Publications for accurate color. PANTONE® and other Pantone trademarks are the property of Pantone LLC. © Pantone LLC, 2015

Pantone is the copyright owner of color data and/or software which are licensed to Esko to distribute for use only in combination with Studio Visualizer. PANTONE Color Data and/or Software shall not be copied onto another disk or into memory unless as part of the execution of Studio Visualizer.

This software is based in part on the work of the Independent JPEG Group.

Portions of this software are copyright © 1996-2002 The FreeType Project ([www.freetype.org](http://www.freetype.org)). All rights reserved.

Portions of this software are copyright 2006 Feeling Software, copyright 2005-2006 Autodesk Media Entertainment.

Portions of this software are copyright ©1998-2003 Daniel Veillard. All rights reserved.

Portions of this software are copyright ©1999-2006 The Botan Project. All rights reserved.

Part of the software embedded in this product is gSOAP software. Portions created by gSOAP are Copyright ©2001-2004 Robert A. van Engelen, Genivia inc. All rights reserved.

Portions of this software are copyright ©1998-2008 The OpenSSL Project and ©1995-1998 Eric Young ([eay@cryptsoft.com](mailto:eay@cryptsoft.com)). All rights reserved.

This product includes software developed by the Apache Software Foundation (<http://www.apache.org/>).

Adobe, the Adobe logo, Acrobat, the Acrobat logo, Adobe Creative Suite, Illustrator, InDesign, PDF, Photoshop, PostScript, XMP and the Powered by XMP logo are either registered trademarks or trademarks of Adobe Systems Incorporated in the United States and/or other countries.

Microsoft and the Microsoft logo are registered trademarks of Microsoft Corporation in the United States and other countries.

SolidWorks is a registered trademark of SolidWorks Corporation.

Portions of this software are owned by Spatial Corp. 1986 2003. All Rights Reserved.

JDF and the JDF logo are trademarks of the CIP4 Organisation. Copyright 2001 The International Cooperation for the Integration of Processes in Prepress, Press and Postpress (CIP4). All rights reserved.

The Esko software contains the RSA Data Security, Inc. MD5 Message-Digest Algorithm.

Java and all Java-based trademarks and logos are trademarks or registered trademarks of Oracle corporation in the U.S. and other countries.

Part of this software uses technology by Best Color Technology (EFI). EFI and Bestcolor are registered trademarks of Electronics For Imaging GmbH in the U.S. Patent and Trademark Office.

Contains PowerNest library Copyrighted and Licensed by Alma, 2005 - 2007.

Part of this software uses technology by GlobalVision. ArtProof and ScanProof are registered trademarks of GlobalVision Inc.

Part of this software uses technology by Qoppa Software. Copyright © 2002-Present. All Rights Reserved.

All other product names are trademarks or registered trademarks of their respective owners.

Correspondence regarding this publication should be forwarded to:

Esko Software BV

Raymonde de Larochelaan 13

B - 9051 Gent

info.eur@esko.com

## 31.1. Third Party Licenses - Automation Engine

---

Find the list of all 3rd party software licenses in a separate document published next to this manual on <https://www.esko.com/en/Support/Product?id=Automation%20Engine>.